

MOTION & CONTROL™

NSK

Precision Machine Components

NSK Linear Guide™
Ball Screws
Monocarrier™

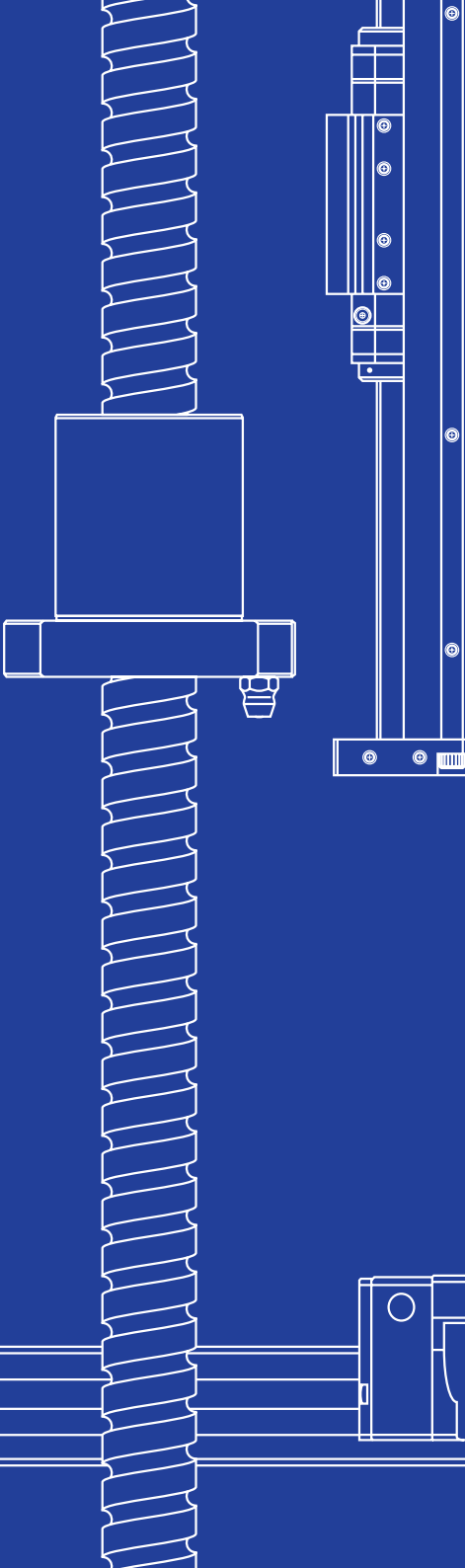

A. NSK Linear Rolling Guide Product

**A1
–
A342**

B. Ball Screws

**B1
–
B584**

C. Monocarrier™

**C1
–
C140**

D. Other

**D1
–
D24**

E. Appendices

**E1
–
E10**

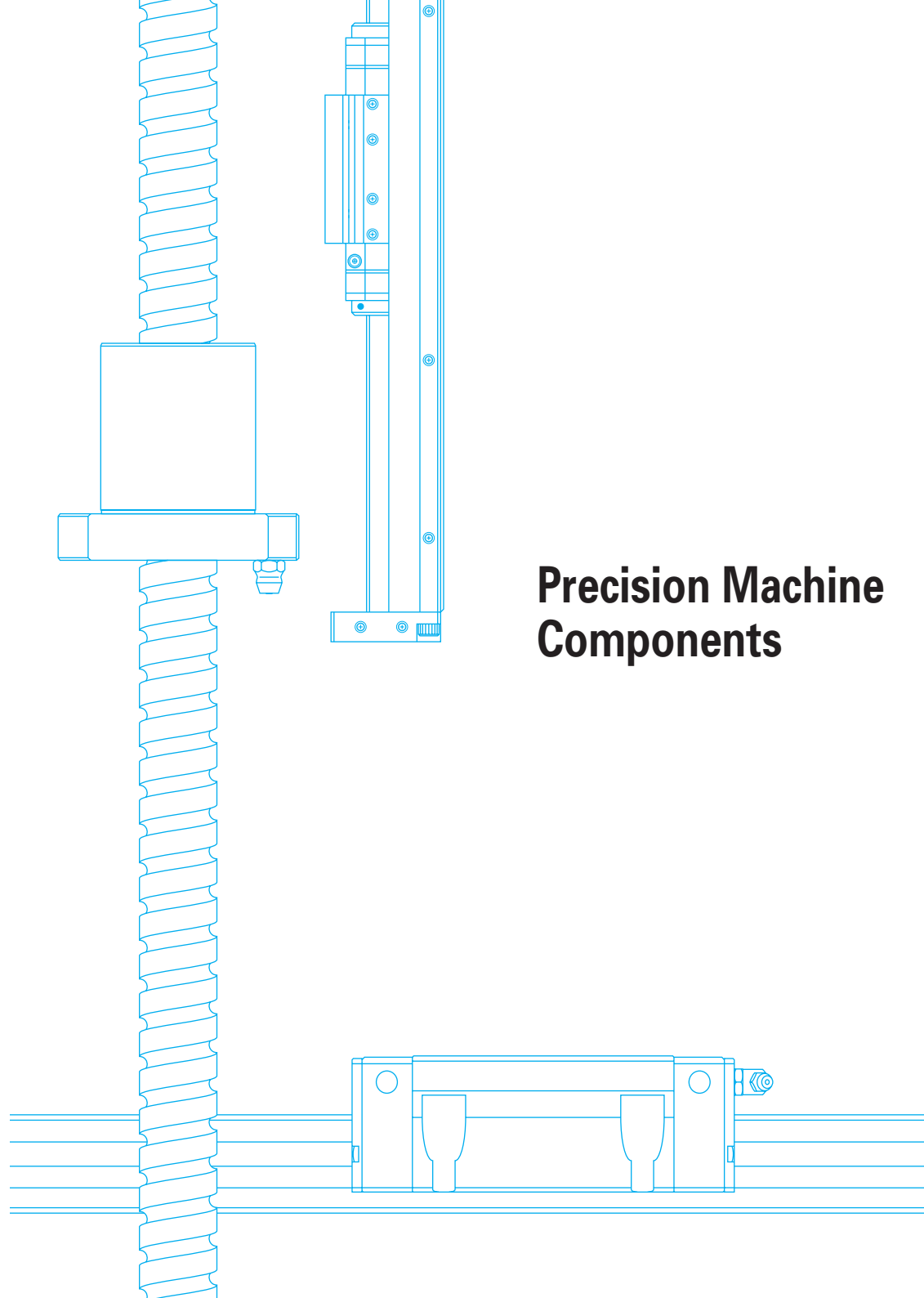

Precision Machine Components

Preface

It is our pleasure to announce the publication of a new catalog which contains all NSK linear motion products. We believe this publication is one way to show our deep appreciation of your patronage.

Market demand for more sophisticated and diversified machines and equipment is rapidly escalating. NSK precision products are not only used widely in these machines, but also are crucial elements.

In response to this trend, ball screws, NSK linear guides, and Monocarriers, which are crucial mechanical components of these machines, are required to be highly reliable, maintenance-free, smaller in size and lightweight. They also are expected to heighten efficiency and satisfy uses in special environment.

Publishing a catalog to introduce our entire product line is especially meaningful under such circumstances.

This is an improved version of the previous catalog; products are categorized, and each product category has two sections. The first section contains an explanation of products for selection and a technical explanation including results of the latest experiments and research to assist thorough technological discussion. The second half is dimension tables. Last, "Other," whose pages are in color, explains special environments and lubrications such as grease, which are general issues for NSK precision products.

We hope abundant NSK products in the new catalog will be your aide in selecting the most suitable products for your purpose. We solicit your continued patronage.

Contents

A. NSK Linear Rolling Guide

A-1 Characteristics of NSK Linear Rolling Guides	
1. Comparison of Rolling Guides and Sliding Guides	A1
2. Structure and Characteristics of NSK Linear Guides	A2
A-2 Types of NSK Linear Rolling Guides	A5
A-3 Selection of NSK Linear Rolling Guides	
1. Selection Flow Chart	A13
2. Rating Life and Basic Load Rating	A15
3. Preload	A28
4. Accuracy	A32
5. Maximum Rail Length	A37
6. Lubrication	A38
7. Dust Proof	A52
8. Rust Prevention (Stainless Steel and Surface Treatment)	A57
9. Special Environment	A60
10. Arrangement and Mounting of Linear Guide	A67
11. Drills to Select Linear Guide	A79
12. Reference	A90
A-4 NSK Linear Guide™	A91
A-5 Technical Description and Dimension Table for NSK Linear Guides	
1. General Industrial Use	A111
2. Liquid Crystal Display and Semiconductor	A185
3. Machine Tools	A247
4. High-Precision Machine and High-Precision Measuring Equipment	A289
A-6 Other Linear Rolling Guide Products	
1. Linear Rolling Bushing	A321
2. Roller Pack	A331
3. Linear Roller Bearings	A338

B. Ball Screws

B-1. Selection Guide to NSK Ball Screw	
1. Features of NSK Ball Screws	B1
2. Structure of a Ball Screw	B3
3. Ball Screw Series	B7
4. Procedures to Select Ball Screw	B17
5. When Placing Orders	B31
B-2 Technical Description of Ball Screws	
1. Accuracy	B37
2. Static Load Limitation	B44
3. Permissible Rotational Speed	B47
4. Supporting Conditions for Calculation of Buckling Load and Critical Speed	B51
5. Life (Dynamic Load Limitation)	B53
6. Preload and Rigidity	B56
7. Friction Torque and Drive Torque	B62
8. Even Load Distribution in Ball Nut (In Case of Ball Screws for High-Load Drive)	B65
9. Lubrication of Ball Screw	B67
10. Dust Prevention for Ball Screw	B68
11. Rust Prevention and Surface Treatment of Ball Screws	B69
12. Ball Screw Specifications for Special Environment	B70
13. Noise and Vibration	B71
14. Installation of Ball Screw	B73
15. Precautions for Designing Ball Screw	B83
16. Shaft End Machining	B86
17. Ball Screw Selection Exercise	B87
18. Reference	B101
19. Guide to Technical Services	B102
20. Precautions When Handling Ball Screws	B103
B-3 Ball Screw Dimension Table	
1. Standard Ball Screws	B105
2. Standard Nut Ball Screws	B429
3. Application-Oriented Ball Screws	B491

C. Monocarrier™

C-1 Monocarrier™	
1. Features	C5
2. Classifications and Series	C7
3. Accessories	C9
4. Selection of Monocarrier	C10
5. MCM Series	C23
6. MCH Series	C71
C-2 Toughcarrier™	
1. Features	C93
2. Classifications and Series	C93
3. Accessories	C95
4. Selection of Toughcarrier	C96
5. TCH Series Dimension Table for Standard Products	C109
6. Accessories	C115
7. Motor Bracket Compatibility Table	C128
8. Sensor Rail and Top Cover Unit Combination Table	C129
9. Toughcarrier High-Thrust Series	C132
C-3 Technical Guide	
1. Sensor Specifications	C135
2. Characteristics and Evaluation Method	C137
3. Special Specifications	C138
4. Maintenance	C139
5. NSK Clean Grease LG2 Specifications	C140

D. Other

1. Special Environments	D1
2. Lubrication	D13
3. RoHS Compliant	D24

E Appendices: Tables

1. Conversion from International System of Units (SI)	E1
2. Conversion Table between N and kgf	E3
3. Conversion Table between kg and lb	E4
4. Conversion Table of Hardness	E5
5. Deviations of Shafts Use in Common Fits	E7
6. Deviations of Holes Used in Common Fits	E9

NSK Linear Rolling Guide Product

A-1 Characteristics of NSK Linear Rolling Guides

- 1. Comparison of Rolling Guides and Sliding Guides.....A1
- 2. Structure and Characteristics of NSK Linear GuidesA2
 - 1. Structure of NSK Linear GuidesA2
 - 2. Characteristics of NSK Linear Guides.....A2

A-2 Types of NSK Linear Rolling GuidesA5

A-3 Selection of NSK Linear Rolling Guides

- 1. Selection Flow ChartA13
- 2. Rating Life and Basic Load RatingA15
 - 2.1 Life and Basic Load Rating...A15
 - 1. LifeA15
 - 2. Rating fatigue life.....A15
 - 3. Basic load ratings in compliance with ISO standardA15
 - 4. Basic dynamic load rating...A15
 - 5. Calculation of rating fatigue lifeA15
 - 6. Dynamic equivalent loadA16
 - 7. Basic static load ratingA16
 - 8. Basic static moment load ratingA16
 - 9. Basic load rating by load direction.....A16
 - 2.2 How to Calculate the LifeA17
 - 1. Setting operating condition of linear guideA17
 - 2. Calculate load to a slideA17
 - 3. Calculation of dynamic equivalent loadA21

- 4. Calculation of mean effective loadA23
- 5. Various coefficientsA24
- 6. Calculation of rating lifeA25
- 7. Examination of the basic load rating.....A26
- 8. Precautions for the design in examining the lifeA27
- 3. Preload.....A28
 - 1. Objective of preloadA28
 - 2. Preload and rigidityA28
 - 3. Selection of preload classification.....A29
 - 4. Estimation of the elastic deformation.....A30
 - 5. Application examples of preloadA30
 - 6. Load and rating life when the preload is taken into accountA31
 - 7. Calculating friction force by preload.....A31
 - 4. AccuracyA32
 - 1. Accuracy standardA32
 - 2. Definition of accuracy.....A32
 - 3. Application example of accuracy grade and preloadA34
 - 4. Combination of accuracy grade and preloadA35
 - 5. Maximum Rail LengthA37
 - 6. LubricationA38
 - 1. NSK linear guides equipped with "NSK K1™" lubrication unit ...A38
 - 2. LubricationA42
 - 7. Dust Proof.....A52
 - 1. Standard specification parts ..A52
 - 2. Dust-proof parts.....A53
 - 8. Rust Prevention (Stainless Steel and Surface Treatment).....A57
 - 1. Stainless steelA57
 - 2. Surface treatmentA57

- 9. Special EnvironmentA60
 - 1. Heat-resistant specifications..A60
 - 2. Vacuum and clean specificationsA60
 - 3. "NSK linear guides for food processing equipment and medical devices" for sanitary environment.....A61
 - 4. Specifications for special environmentsA63
 - 5. Lubrication and materialsA64
 - 6. Responsiveness of NSK linear guides for special environmentsA66
 - 7. Precautions for handling.....A66
- 10. Arrangement and Mounting of Linear GuidesA67
 - 1. Arrangement.....A67
 - 2. Mounting accuracyA69
 - 3. Installation.....A72
 - 4. Assembly random-matching type linear guideA77
 - 5. Butting rail specificationA77
 - 6. Handling preloaded assemblyA78
- 11. Drills to Select Linear Guide ...A79
 - 1. Single axis material handling systemA79
 - 2. Machining centerA84
- 12. Reference.....A90

A-4 NSK Linear Guide™

- 1. Structure of NSK Linear GuidesA91
- 2. Characteristics of NSK Linear Guides.....A91
- 3. Types and Characteristics of NSK Linear Guides.....A93
- 4. Guide to Technical Services....A107
- 5. Linear Guides: Handling Precautions.....A108
- 6. Design Precautions.....A109

A-5 Technical Description and Dimension Table for NSK Linear Guides

- 1. General Industrial Use
 - 1.1 NH Series.....A113
 - 1.2 VH SeriesA133
 - 1.3 NS Series.....A153
 - 1.4 LW Series.....A171
- 2. Liquid Crystal Display and Semiconductor
 - 2.1 PU Series.....A187
 - 2.2 LU SeriesA197
 - 2.3 PE Series.....A209
 - 2.4 LE Series.....A219
 - 2.5 Miniature LH SeriesA233
 - 2.6 LL Series.....A243
- 3. Machine Tools
 - 3.1 RA SeriesA249
 - 3.2 LA SeriesA271
- 4. High-Precision Machine and High-Precision Measuring Equipment
 - 4.1 HA Series.....A291
 - 4.2 HS SeriesA305
- 5. The Comparative Table of New and Former Series.....A319

A-6 Other Linear Rolling Guide Products

- 1. Linear Rolling Bushing.....A321
- 2. Roller Pack.....A331
- 3. Linear Roller Bearings.....A338

A-1 Characteristics of NSK Linear Rolling Guides

Characteristics of the NSK linear rolling guides are:

- Designs are simple and economic. This contributes to a highly accurate and low cost guide way system.
- Low friction coefficient facilitates a compact and low cost driving mechanism.
- Ultra-high purity of materials and superb processing technology ensure a long-term reliable operation.
- Prompt delivery thanks to a variety of interchangeable components.
- Users can select the most suitable guide from a wide variety of the ball guides and roller guides.

A-1-1 Comparison of Rolling Guides and Sliding Guides

The following describes a characteristic comparison between general rolling and sliding guide ways.

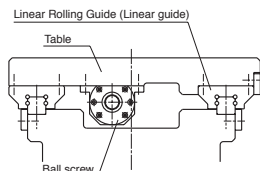

Example of rolling guide

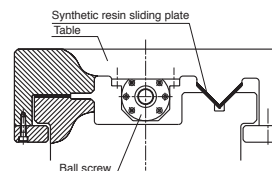

Example of sliding guide

Comparative characteristics of rolling and sliding guide ways

Function	Rolling guide	Sliding guide
Friction	<ul style="list-style-type: none"> • Friction coefficient: 0.01 or lower • Difference between static and dynamic friction is small. • The fluctuation of friction force due to varying speed is far less than sliding guides. 	<ul style="list-style-type: none"> • Friction is high. • The difference between static and dynamic friction coefficient is significant.
Positioning accuracy	<ul style="list-style-type: none"> • Lost motion is minimal. • Stick-slip is minimal. • Easy to achieve sub-micron positioning 	<ul style="list-style-type: none"> • Larger lost motion • Stick-slip at low speed • Difficult to achieve sub-micron positioning
Life	<ul style="list-style-type: none"> • Possible to estimate useful life 	<ul style="list-style-type: none"> • Difficult to estimate useful life
Static rigidity	<ul style="list-style-type: none"> • Generally high • No play because of preload • Easy to estimate rigidity 	<ul style="list-style-type: none"> • Rigidity is great against load from a particular direction. • There is a mechanical play. • Difficult to estimate rigidity
Speed	<ul style="list-style-type: none"> • Wide range of use from low to high speed 	<ul style="list-style-type: none"> • Unsuitable for extremely low or high speed
Maintenance, reliability	<ul style="list-style-type: none"> • Long life through a simple maintenance 	<ul style="list-style-type: none"> • Precision is lost greatly by a worn out slide way surface.

In response to the demand for a high-speed, high-precision, high-quality, and easy maintenance, rolling guides which have above features are becoming prevalent. Utilizing the technology we have sharpened in anti-friction rotating bearings, NSK makes various types of rolling linear guides which are highly accurate and reliable.

A-1-2 Structure and Characteristics of NSK Linear Guides

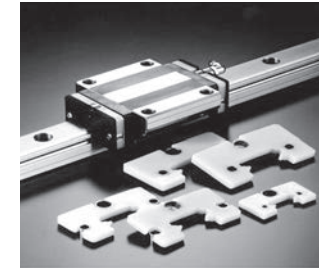
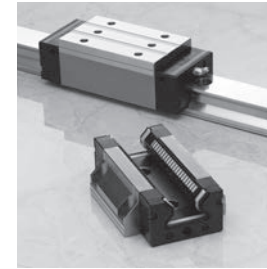

1. Structure of NSK Linear Guides

By avoiding structural complexity, and by reducing the number of components, we not only enhanced the precision of linear guides, but also are able to keep costs low. We have added NSK's patented unique structural feature to the original invention (Fig. 1). This contributes to higher precision and lower prices.

NSK linear guides consist of a rail and a slide (Fig. 2). The balls or rollers roll on the race way surface, and are scooped up by the end caps attached to both ends of the ball or roller slide. Then, the balls or rollers go through a passage made in the slide, and circulate back to the other end.

2. Characteristics of NSK Linear Guides

The use of a unique offset Gothic arch groove (Fig. 3) allows the ball type of NSK linear guides to satisfy groove designs required for specific purposes.

This unique ball groove design facilitates precise measurement of the ball groove, thus enabling the stable and highly accurate production of the rails and ball slides for random matching. (Fig. 4)

On top of that, we have developed and marketed the NSK Roller Guides, representing the culmination of NSK's analysis technology and tribology.

Such technologies ensure the features of NSK linear guides outlined below.

(1) High precision and quality

- High precision and quality come from our superb production and measuring technologies, strengthened by extensive experience in antifriction rotary bearings and ball screw production. Our quality assurance extends to the smallest components.

(2) High reliability and durability

- Logical simplicity in shape, along with stable processing, maintains high precision and reliability.
- Super-clean materials, our advanced heat treatment and processing technologies increase product durability.

(3) Abundant in type for any purpose

- Various series are available, and their slide models and size categories are standardized to satisfy any requirement. Our technology, polished by abundant experience in the use of special materials and surface treatments, meets the customer's most demanding expectations.

(4) Development of random-matching parts for short delivery time

- The adoption of the Gothic arch groove which makes measuring easy, and a new reliable quality control method has made random-matching of the rails and the ball slides possible. The parts are stocked as standard products, thereby reducing delivery time.

(5) Patented static load carrying capacity (impact-resistance)

- When a super-high load (impact) is applied, our Gothic arch groove spreads the load to surfaces which usually do not come into contact in the ball type NSK linear guides. This increases impact load resistance (Fig. 5).

(6) Lineup of extremely high-load capacity series

- The LA series provides a top class high-load capacity for the ball linear guides through a unique load carrying configuration with three ball recirculation circuits on the one side.

By installing rollers that are the largest possible diameter and length, the NSK roller linear guides have realized the world's highest load capacity, far superior to the roller linear guides of other companies.

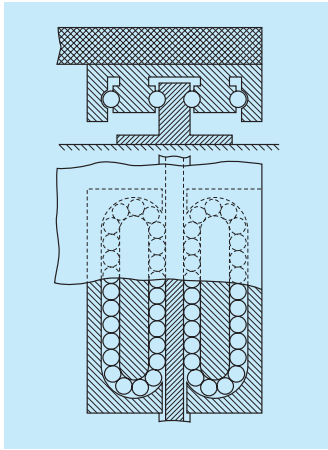

Fig. 1 • French Patent in 1932.
• Inventor: Gretsh (German)

NSK added its patented technology to the invention in Fig. 1, and improved the linear guide structure, thus realizing low cost design.

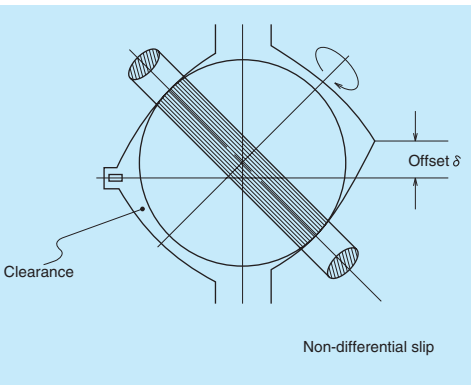

Fig. 3 Two point contacts of the offset Gothic arch groove

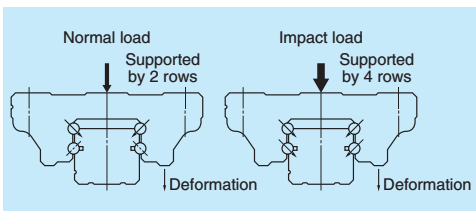

Fig. 5 Shock-resistance

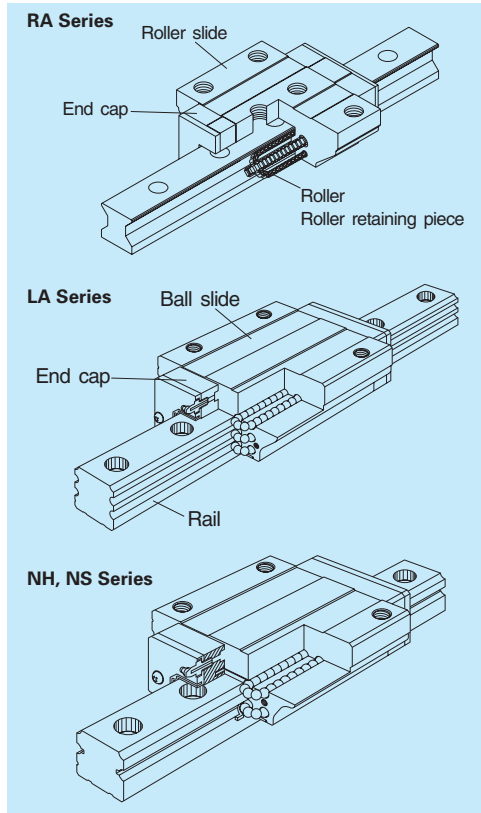

Fig. 2 Structure of NSK linear guides

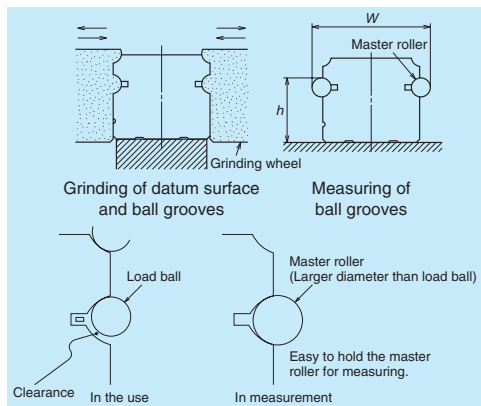
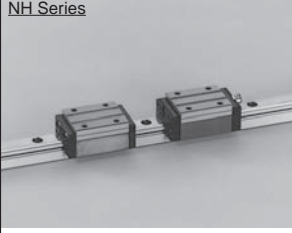
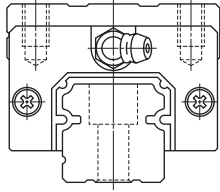
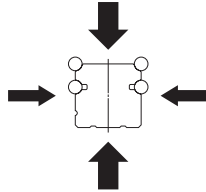
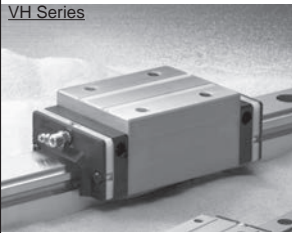
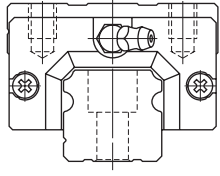
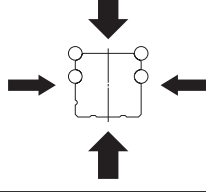
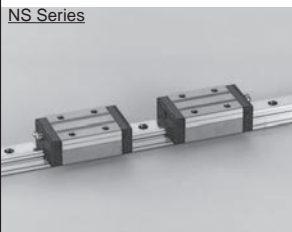
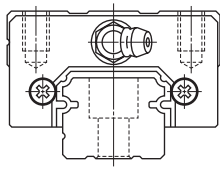
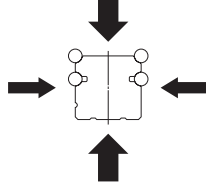

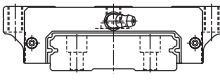
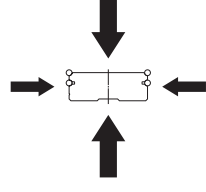

Fig. 4 Processing and measuring grooves

Measuring grooves is easy: you can obtain highly accurate results for all types of NSK series. This is why you can purchase rails and slides separately for random matching.

A-2 Types of NSK Linear Rolling Guides

Product	Appearance	Shape	Rolling element	Load carrying characteristics
NSK Linear Guides	NH Series 		Ball	High vertical load carrying capacity 
	VH Series 		Ball	High vertical load carrying capacity 
	NS Series 		Ball	High vertical load carrying capacity 
	LW Series 		Ball	High vertical load carrying capacity 





Note: For customers who have used the former LH or SH (LS or SS) series, NH (NS) series is recommended as a substitute. Please confirm the correlation between NH (NS) series and former ones on the comparative table at A319.





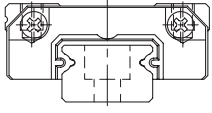
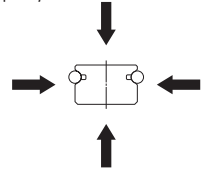
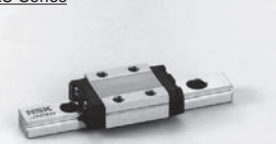
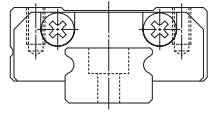
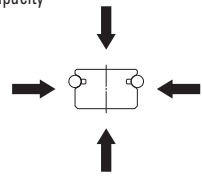

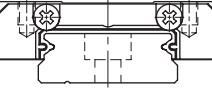
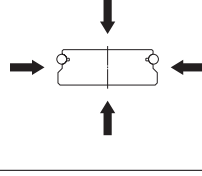

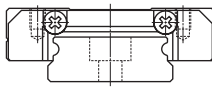
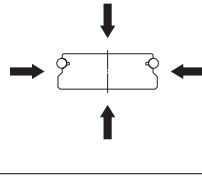
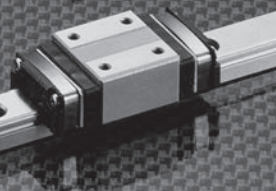
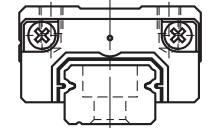
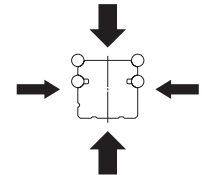
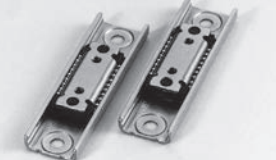
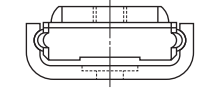
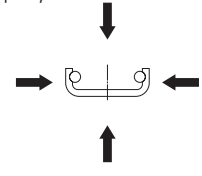









Rigidity: ☆, Extremely high; ◎, High; ○, Medium; ○, Low





Friction characteristics: ◎, Low; ○, Normal





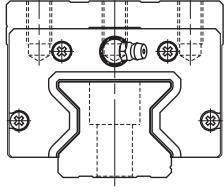
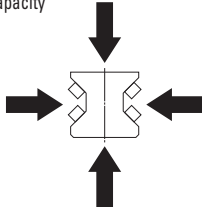
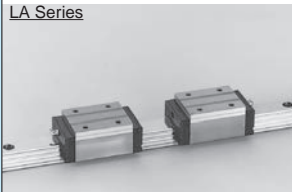
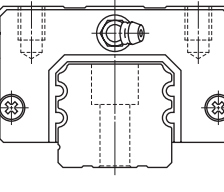
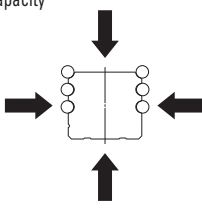

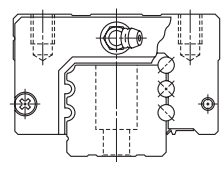
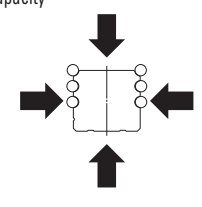

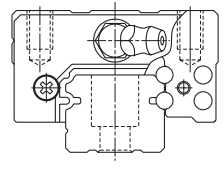
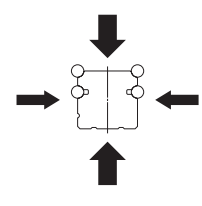



Assembly workability: ◎, Good; ○, Fair



Rigidity	Friction characteristic	Assembly workability	Major applications	Page
◎	◎	◎	<ul style="list-style-type: none"> Industrial robots Materials handling equipment Semiconductor manufacturing equipment Laser cutting machines Electric discharge machines Packaging/packing machines 	A113
◎	◎	◎	<ul style="list-style-type: none"> Industrial robots Materials handling equipment Woodworking machines Laser cutting machines Electric discharge machines Packaging/packing machines 	A133
◎	◎	◎	<ul style="list-style-type: none"> Industrial robots Materials handling equipment Electric discharge machines Woodworking machines Semiconductor manufacturing equipment Packaging/packing machines Pneumatic equipment 	A153
◎	◎	◎	<ul style="list-style-type: none"> Industrial robots Materials handling equipment Electric discharge machines Woodworking machines Semiconductor manufacturing equipment Packaging/packing machines Pneumatic equipment 	A171







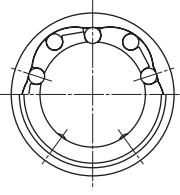
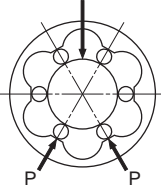

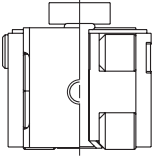
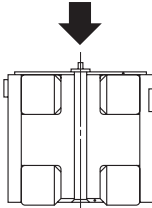
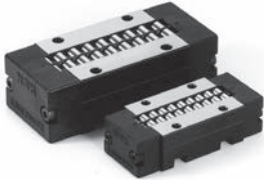
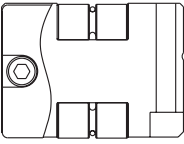
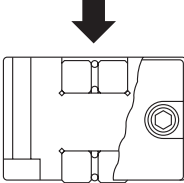
Product	Appearance	Shape	Rolling element	Load carrying characteristics
NSK Linear Guides	PU Series 		Ball	Four-way equal load carrying capacity 
	LU Series 		Ball	Four-way equal load carrying capacity 
	PE Series 		Ball	Four-way equal load carrying capacity 
	LE Series 		Ball	Four-way equal load carrying capacity 
	Miniature LH Series 		Ball	High vertical load carrying capacity 
	LL Series 		Ball	Four-way equal load carrying capacity 

Rigidity	Friction characteristic	Assembly workability	Major applications	Page
			<ul style="list-style-type: none"> • Semiconductor manufacturing equipment • LCD manufacturing equipment • Medical equipment • Optical stages • Microscope XY stages • Miniature robots • Pneumatic equipment • Computer peripherals 	A187
			<ul style="list-style-type: none"> • Semiconductor manufacturing equipment • LCD manufacturing equipment • Medical equipment • Optical stages • XY stage of microscope • Miniature robots • Pneumatic equipment • Computer peripherals 	A197
			<ul style="list-style-type: none"> • Semiconductor manufacturing equipment • LCD manufacturing equipment • Medical equipment • Optical stages • Microscope XY stages • Miniature robots • Pneumatic equipment • Computer peripherals 	A209
			<ul style="list-style-type: none"> • Semiconductor manufacturing equipment • LCD manufacturing equipment • Medical equipment • Optical stages • XY stages of microscope • Miniature robots • Pneumatic equipment • Computer peripherals 	A219
			<ul style="list-style-type: none"> • Semiconductor manufacturing equipment • LCD manufacturing equipment • Medical equipment • Optical stages • Microscope XY stages • Miniature robots • Pneumatic equipment • Computer peripherals 	A233
			<ul style="list-style-type: none"> • Knitting machines • Computer peripherals • Pneumatic equipment • Office equipment 	A243

Product	Appearance	Shape	Rolling element	Load carrying characteristics
NSK Linear Guides	RA Series 		Roller	Four-way equal load carrying capacity 
	LA Series 		Ball	Four-way equal load carrying capacity 
	HA Series 		Ball	Four-way equal load carrying capacity 
	HS Series 		Ball	High vertical load carrying capacity 

Rigidity	Friction characteristic	Assembly workability	Major applications	Page
			<ul style="list-style-type: none"> • Machining centers • NC lathes • Heavy cutting machine tools • Various types of NC grinders • Gear-cutting machines • Press machines • Electric discharge machines 	A249
			<ul style="list-style-type: none"> • Machining centers • NC lathes • Heavy cutting machine tools • Various types of NC grinders • Gear-cutting machines • Press machines • Electric discharge machines 	A271
			<ul style="list-style-type: none"> • Machining centers • Precision lathes • Various types of NC grinders • Electric discharge machines • Optical stages • LCD manufacturing equipment • Die molding machines • High-precision measuring equipment 	A291
			<ul style="list-style-type: none"> • Machining centers • Precision lathes • Various types of grinders • Electric discharge machines • Optical stages • LCD manufacturing equipment • High-precision measuring equipment 	A305

Product	Appearance	Shape	Rolling element	Load carrying characteristics
Linear rolling bushing			Ball	
Roller pack			Roller	
Linear roller bearing			Roller	

Rigidity	Friction characteristic	Assembly workability	Major applications	Page
			<ul style="list-style-type: none"> • Materials handling equipment • Packaging/packing machines • Medical equipment • Pneumatic equipment • Office equipment • Assembling machines 	A321
			<ul style="list-style-type: none"> • Large machine tools • Conveyor system for heavy objects (guide ways for heavy loads) 	A331
			<ul style="list-style-type: none"> • Large machine tools • Conveyor system for heavy objects (guide ways for heavy loads) 	A338

A-3 Selection of NSK Linear Rolling Guides

A-3-1 Selection Flow Chart

The flow chart below shows the basic steps for the selection.

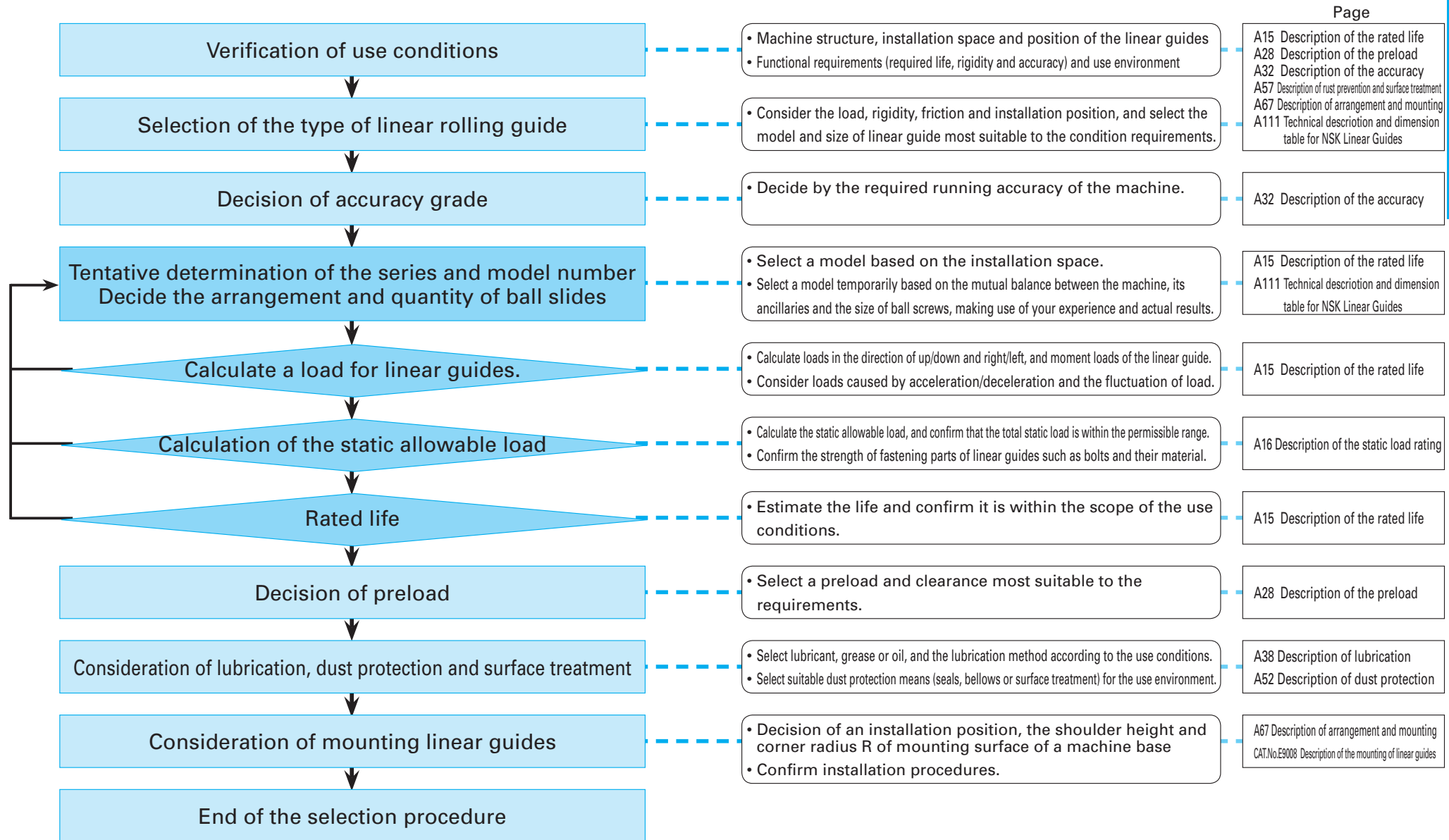

A-3-2 Rating Life and Basic Load Rating

A-3-2.1 Life and Basic Load Rating

1. Life

Although used in appropriate conditions, the linear guide deteriorates after a certain period of operation, and eventually becomes unusable. In broad definition, the period until the linear guide becomes unusable is called "life." There are "fatigue life" caused by flaking, and "accuracy life" which is the result of wear components.

2. Rating fatigue life

When the linear guide runs under loads, the rolling elements and the rolling contact surface of the grooves are exposed to repetitive stress. This brings about fatigue to the material, and generates flaking. Flaking is scale-like damage to the surface of the rolling contact surface.

Total running distance until first appearance of flaking is called "fatigue life." This is "life" in the narrow sense. The fatigue life varies significantly even in linear guides produced in the same lot, and even when they are operated under the same conditions. This is attributable to the inherent variation of the fatigue of the material itself.

"Rating fatigue life" is the total running distance which allows 90% of the group of linear guides of the same reference number to run without causing flaking when they are independently run under the same conditions. The rating fatigue life is sometimes indicated by total operating hours when the linear guides run at a certain speed.

3. Basic load ratings in compliance with ISO standard

NSK defines the basic load rating in compliance with the ISO standard.

The basic load rating listed in "A-5 Technical Description and Dimension Table for NSK Linear Guides." comply with the ISO standard.

ISO: International Organization for Standardization

[Basic dynamic load rating]

ISO 14728-1; Rolling bearings — Linear motion rolling bearings

Part 1: Dynamic load ratings and rating life

[Basic static load rating]

ISO 14728-2; Rolling bearings — Linear motion rolling bearings

Part 2: Static load ratings

4. Basic dynamic load rating

- ISO international standard, the basic dynamic load rating, which indicates load carrying capacity of the linear guide, is a load whose direction and volume do not change, and which furnishes 100 km of rating fatigue life.
- In case of the linear guides, it is a constant load applied to downward direction to the center of the slide.
- For balls as rolling element, some linear guide manufacturers in Japan and Asian countries define the load for the basic fatigue life of 50 km as the basic dynamic load ratings.

- The following formula may be used to convert the basic dynamic load rating for 50 km (C_{50}) into the dynamic load rating for 100 km (C_{100}) rated fatigue life.

$$\text{• For balls as rolling element} \quad C_{100} = \frac{C_{50}}{1.26}$$

$$\text{• For rollers as rolling element} \quad C_{100} = \frac{C_{50}}{1.23}$$

5. Calculation of rating fatigue life

- In general, the rating fatigue life "L" can be calculated from the basic dynamic load rating "C" and the load "F" to a slide using the following formula.

[For balls as rolling element] The third power of the index.

For the basic dynamic load rating for 100 km

$$L = 100 \times \left(\frac{C_{100}}{F} \right)^3$$

For the basic dynamic load rating for 50 km

$$L = 50 \times \left(\frac{C_{50}}{F} \right)^3$$

[For rollers as rolling element] The ten third power of the index.

For the basic dynamic load rating for 100 km

$$L = 100 \times \left(\frac{C_{100}}{F} \right)^{\frac{10}{3}}$$

For the basic dynamic load rating for 50 km

$$L = 50 \times \left(\frac{C_{50}}{F} \right)^{\frac{10}{3}}$$

L ; Rating fatigue life (km)

C_{100} ; Basic dynamic load rating for 100 km rated fatigue life (N)

C_{50} ; Basic dynamic load rating for 50 km rated fatigue life (N)

F ; Load to a slide (dynamic equivalent load) (N)

6. Dynamic equivalent load

- Loads applied to the linear guide (slide load) comes from various directions up/down and right/left directions and/or as moment loads. Sometimes more than one type of load is applied simultaneously. Sometimes the volume and direction of the load may change.

Various loads cannot be used as they are to calculate the life of the linear guide. Therefore, it is necessary to use a hypothetical load on the slide with a constant volume, which would generate a value equivalent to an actual fatigue life. This is called "dynamic equivalent load." For actual calculation, refer to "A-3-2.2 3. Calculation of dynamic equivalent load"

7. Basic static load rating

- When an excessive load or a momentary large impact is applied to the linear guide, local permanent deformation takes place on the rolling elements and on the rolling contact surfaces. After exceeding a certain level, the deformation hampers smooth linear guide operation.
- Basic static load rating is a static load when: [Permanent deformation of the rolling elements] + [permanent deformation of the rolling contact surfaces] becomes approximately 0.0001 times of the rolling element diameter.
- In the case of the linear guides, it is a load which is applied in downward direction to the center of the slide.
- Values of the basic static load rating C_0 are shown in "A-5 Technical Description and Dimension Table for NSK Linear Guides."

8. Basic static moment load rating

- Generally, NSK linear guides use a set of two rails and four slides for the guide way of one axis. Under some operating condition, static moment load should be taken into account.

" M_0 ," which is the limit of static moment load, and calculated from permanent deformation in such use is shown in "A-5 Technical Description and Dimension Table for NSK Linear Guides."

9. Basic load rating by load direction

- The basic load rating is considered to be a downward load to the slide and is indicated in the dimension tables as the dynamic load rating C and the static load rating C_0 respectively. However, the load may be applied to a slide in upward or lateral directions in actual use. In such a case the basic load rating shall be compensated as shown in Table 2.1. The basic dynamic load rating of the RA and LA Series is the same in C and C_0 for all load directions, up, down and lateral, while the NH Series, for an example, has different basic load ratings by the load direction as shown in the table.

Table 2.1 Basic load ratings by load direction

Series	Load rating Load direction	Basic dynamic load rating			Basic static load rating		
		Downward	Upward	Lateral	Downward	Upward	Lateral
NH, VH, NS, LW, LH, HS		C	C	0.84C	C_0	0.78 C_0	0.65 C_0
PU, LU, PE, LE, LL, RA, LA, HA		C	C	C	C_0	C_0	C_0

A-3-2.2 How to Calculate the Life

1. Setting operating condition of linear guide

- First, set operating conditions to determine whether the temporarily selected model satisfies the required life.
- Major operating conditions are as follows. Set all values to calculate applied loads to each slide. (Refer to **Table 2.2.**)

- Axis set up : Horizontal or vertical
- Rail combination : Single rail or multiple rail
- Applying loads : F_x, F_y and F_z (N)
- Slide span : l (mm)
- Rail span : L (mm)
- Position of load action point : X, Y, Z (mm)
- Center of driving mechanism : X_b, Y_b, Z_b (mm)
- Operating speed : V (mm/sec)
- Time in acceleration : t (sec)
- Operating frequency (duty cycle)

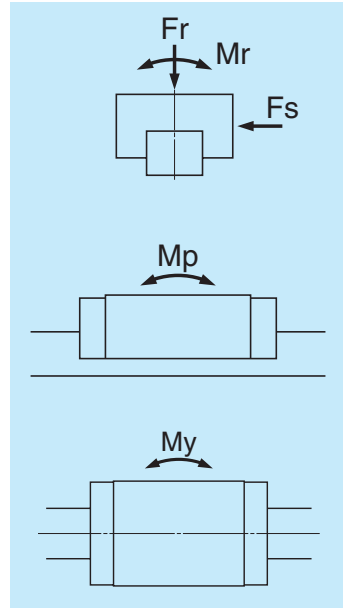

Fig. 2.1

2. Calculating load to a slide

- **Table 2.2** shows a formula to calculate loads that are going to be applied to each assembled slide into a machine. The Table shows six typical patterns of linear guide installing structure.
- In the Tables, directions indicated by arrows denote "plus" for the applied loads (F_x, F_y, F_z) and the loads which are applied to the slides. ($F_r, F_{sr}, M_r, M_{pr}, M_y$)
- Codes in the Tables are as follows:

- F_r : Vertical loads to the slide (N)
- F_s : Lateral loads to the slide (N)
- M_r : Rolling moment to the slide (N · mm)
- M_p : Pitching moment to the slide (N · mm)
- M_y : Yawing moment to the slide (N · mm)
- Suffixes (1, 2, ...) to the above $F_r - M_r$: Slide number
- F_{xi} : Load applied in X direction ($i = 1$ to n ; n is the number of loads applied in X direction) (N)
- F_{yj} : Load applied in Y direction ($j = 1$ to n ; n is the number of loads applied in Y direction) (N)
- F_{zk} : Load applied in Z direction ($k = 1$ to n ; n is the number of loads applied in Z direction) (N)
- Coordinates (X_{xi}, Y_{xi}, Z_{xi}): Point where load F_{xi} (mm) is applied.
- Coordinates (X_{yj}, Y_{yj}, Z_{yj}): Point where load F_{yj} (mm) is applied.
- Coordinates (X_{zk}, Y_{zk}, Z_{zk}): Point where load F_{zk} (mm) is applied.
- l : Slide span (mm)
- L : Rail span (mm)
- Coordinates (X_b, Y_b, Z_b): Center of driving mechanism

Table 2.2 Loads applied to the slides

Pattern	Arrangement of slides	Load to slide and deformation at Point A
1		$F_{r1} = \sum_{k=1}^n F_{zk} \quad , \quad F_{s1} = \sum_{j=1}^n F_{yj}$ $M_{r1} = \sum_{j=1}^n (F_{yj} \cdot Z_{yj}) + \sum_{k=1}^n (F_{zk} \cdot Y_{zk})$ $M_{p1} = \sum_{i=1}^n \{F_{xi} \cdot (Z_{xi} - Z_b)\} + \sum_{k=1}^n (F_{zk} \cdot X_{zk})$ $M_{y1} = -\sum_{i=1}^n \{F_{xi} \cdot (Y_{xi} - Y_b)\} + \sum_{j=1}^n (F_{yj} \cdot X_{yj})$
2		$F_{r1} = \frac{\sum_{k=1}^n F_{zk}}{2} + \frac{M2}{l} \quad , \quad F_{r2} = \frac{\sum_{k=1}^n F_{zk}}{2} - \frac{M2}{l}$ $F_{s1} = \frac{\sum_{j=1}^n F_{yj}}{2} + \frac{M3}{l} \quad , \quad F_{s2} = \frac{\sum_{j=1}^n F_{yj}}{2} - \frac{M3}{l}$ $M_{r1} = \frac{M1}{2} \quad , \quad M_{r2} = \frac{M1}{2}$ $M1 = \sum_{j=1}^n (F_{yj} \cdot Z_{yj}) + \sum_{k=1}^n (F_{zk} \cdot Y_{zk})$ $M2 = \sum_{i=1}^n \{F_{xi} \cdot (Z_{xi} - Z_b)\} + \sum_{k=1}^n (F_{zk} \cdot X_{zk})$ $M3 = -\sum_{i=1}^n \{F_{xi} \cdot (Y_{xi} - Y_b)\} + \sum_{j=1}^n (F_{yj} \cdot X_{yj})$
3		$F_{r1} = \frac{\sum_{k=1}^n F_{zk}}{2} + \frac{M1}{L} \quad , \quad F_{r2} = \frac{\sum_{k=1}^n F_{zk}}{2} - \frac{M1}{L}$ $F_{s1} = F_{s2} = \frac{\sum_{j=1}^n F_{yj}}{2}$ $M_{p1} = M_{p2} = \frac{M2}{2} \quad , \quad M_{y1} = M_{y2} = \frac{M3}{2}$ $M1 = \sum_{j=1}^n (F_{yj} \cdot Z_{yj}) + \sum_{k=1}^n (F_{zk} \cdot Y_{zk})$ $M2 = \sum_{i=1}^n \{F_{xi} \cdot (Z_{xi} - Z_b)\} + \sum_{k=1}^n (F_{zk} \cdot X_{zk})$ $M3 = -\sum_{i=1}^n \{F_{xi} \cdot (Y_{xi} - Y_b)\} + \sum_{j=1}^n (F_{yj} \cdot X_{yj})$

Pattern	Arrangement of slides	Load to slide and deformation at Point A
4		$Fr_1 = \frac{\sum_{k=1}^n F_{Zk}}{4} + \frac{M1}{2L} + \frac{M2}{2l}, \quad Fr_2 = \frac{\sum_{k=1}^n F_{Zk}}{4} + \frac{M1}{2L} - \frac{M2}{2l}$ $Fr_3 = \frac{\sum_{k=1}^n F_{Zk}}{4} - \frac{M1}{2L} + \frac{M2}{2l}, \quad Fr_4 = \frac{\sum_{k=1}^n F_{Zk}}{4} - \frac{M1}{2L} - \frac{M2}{2l}$ $Fs_1 = Fs_3 = \frac{\sum_{j=1}^n F_{Yj}}{4} + \frac{M3}{2l}, \quad Fs_2 = Fs_4 = \frac{\sum_{j=1}^n F_{Yj}}{4} - \frac{M3}{2l}$ $M1 = \sum_{j=1}^n \{F_{Yj} \cdot Z_{yj}\} + \sum_{k=1}^n \{F_{Zk} \cdot Y_{zk}\}$ $M2 = \sum_{i=1}^n \{F_{Xi} \cdot (Z_{xi} - Zb)\} + \sum_{k=1}^n \{F_{Zk} \cdot X_{zk}\}$ $M3 = -\sum_{i=1}^n \{F_{Xi} \cdot (Y_{xi} - Yb)\} + \sum_{j=1}^n \{F_{Yj} \cdot X_{yj}\}$ $\delta x = Y_d \cdot \frac{Fs_2 - Fs_1}{l \cdot Ks} + Z_d \cdot \frac{Fr_1 - Fr_2}{l \cdot Kr}$ $\delta y = \frac{\sum_{j=1}^n F_{Yj}}{4 \cdot Ks} + X_d \cdot \frac{Fs_1 - Fs_2}{l \cdot Ks} + Z_d \cdot \frac{Fr_1 - Fr_3}{l \cdot Kr}$ $\delta z = \frac{\sum_{k=1}^n F_{Zk}}{4 \cdot Kr} + X_d \cdot \frac{Fr_1 - Fr_2}{l \cdot Kr} + Y_d \cdot \frac{Fr_1 - Fr_3}{l \cdot Kr}$

5		$Fr_1 = \frac{\sum_{k=1}^n F_{Zk}}{6} + \frac{M1}{3L} + \frac{M2}{2l}, \quad Fr_2 = \frac{\sum_{k=1}^n F_{Zk}}{6} + \frac{M1}{3L}$ $Fr_3 = \frac{\sum_{k=1}^n F_{Zk}}{6} + \frac{M1}{3L} - \frac{M2}{2l}, \quad Fr_4 = \frac{\sum_{k=1}^n F_{Zk}}{6} - \frac{M1}{3L} + \frac{M2}{2l}$ $Fr_5 = \frac{\sum_{k=1}^n F_{Zk}}{6} - \frac{M1}{3L}, \quad Fr_6 = \frac{\sum_{k=1}^n F_{Zk}}{6} - \frac{M1}{3L} - \frac{M2}{2l}$ $Fs_1 = Fs_4 = \frac{\sum_{j=1}^n F_{Yj}}{6} + \frac{M3}{2l}, \quad Fs_2 = Fs_5 = \frac{\sum_{j=1}^n F_{Yj}}{6}$ $Fs_3 = Fs_6 = \frac{\sum_{j=1}^n F_{Yj}}{6} - \frac{M3}{2l}$ $M1 = \sum_{j=1}^n \{F_{Yj} \cdot Z_{yj}\} + \sum_{k=1}^n \{F_{Zk} \cdot Y_{zk}\}$ $M2 = \sum_{i=1}^n \{F_{Xi} \cdot (Z_{xi} - Zb)\} + \sum_{k=1}^n \{F_{Zk} \cdot X_{zk}\}$ $M3 = -\sum_{i=1}^n \{F_{Xi} \cdot (Y_{xi} - Yb)\} + \sum_{j=1}^n \{F_{Yj} \cdot X_{yj}\}$ $\delta x = Y_d \cdot \frac{Fs_3 - Fs_1}{l \cdot Ks} + Z_d \cdot \frac{Fr_1 - Fr_3}{l \cdot Kr}$ $\delta y = \frac{\sum_{j=1}^n F_{Yj}}{6 \cdot Ks} + X_d \cdot \frac{Fs_1 - Fs_3}{l \cdot Ks} + Z_d \cdot \frac{Fr_1 - Fr_4}{l \cdot Kr}$ $\delta z = \frac{\sum_{k=1}^n F_{Zk}}{6 \cdot Kr} + X_d \cdot \frac{Fr_1 - Fr_3}{l \cdot Kr} + Y_d \cdot \frac{Fr_1 - Fr_4}{l \cdot Kr}$
---	--	--

Pattern	Arrangement of slides	Load to slide and deformation at Point A
6		$Fr_1 = \frac{\sum_{k=1}^n F_{Zk}}{8} + \frac{M1}{4L} + \frac{M2 \cdot l'}{2 \cdot (l^2 + l'^2)}$ $Fr_2 = \frac{\sum_{k=1}^n F_{Zk}}{8} + \frac{M1}{4L} + \frac{M2 \cdot l}{2 \cdot (l^2 + l'^2)}$ $Fr_3 = \frac{\sum_{k=1}^n F_{Zk}}{8} + \frac{M1}{4L} - \frac{M2 \cdot l}{2 \cdot (l^2 + l'^2)}$ $Fr_4 = \frac{\sum_{k=1}^n F_{Zk}}{8} + \frac{M1}{4L} - \frac{M2 \cdot l'}{2 \cdot (l^2 + l'^2)}$ $Fr_5 = \frac{\sum_{k=1}^n F_{Zk}}{8} - \frac{M1}{4L} + \frac{M2 \cdot l'}{2 \cdot (l^2 + l'^2)}$ $Fr_6 = \frac{\sum_{k=1}^n F_{Zk}}{8} - \frac{M1}{4L} + \frac{M2 \cdot l}{2 \cdot (l^2 + l'^2)}$ $Fr_7 = \frac{\sum_{k=1}^n F_{Zk}}{8} - \frac{M1}{4L} - \frac{M2 \cdot l}{2 \cdot (l^2 + l'^2)}$ $Fr_8 = \frac{\sum_{k=1}^n F_{Zk}}{8} - \frac{M1}{4L} - \frac{M2 \cdot l'}{2 \cdot (l^2 + l'^2)}$ $Fs_1 = Fs_3 = \frac{\sum_{j=1}^n F_{Yj}}{8} + \frac{M3 \cdot l'}{2 \cdot (l^2 + l'^2)}$ $Fs_2 = Fs_6 = \frac{\sum_{j=1}^n F_{Yj}}{8} + \frac{M3 \cdot l}{2 \cdot (l^2 + l'^2)}$ $Fs_3 = Fs_7 = \frac{\sum_{j=1}^n F_{Yj}}{8} - \frac{M3 \cdot l}{2 \cdot (l^2 + l'^2)}$ $Fs_4 = Fs_8 = \frac{\sum_{j=1}^n F_{Yj}}{8} - \frac{M3 \cdot l'}{2 \cdot (l^2 + l'^2)}$ $M1 = \sum_{j=1}^n \{F_{Yj} \cdot Z_{yj}\} + \sum_{k=1}^n \{F_{Zk} \cdot Y_{zk}\}$ $M2 = \sum_{i=1}^n \{F_{Xi} \cdot (Z_{xi} - Zb)\} + \sum_{k=1}^n \{F_{Zk} \cdot X_{zk}\}$ $M3 = -\sum_{i=1}^n \{F_{Xi} \cdot (Y_{xi} - Yb)\} + \sum_{j=1}^n \{F_{Yj} \cdot X_{yj}\}$ $\delta x = Y_d \cdot \frac{Fs_4 - Fs_1}{l_2 \cdot Ks} + Z_d \cdot \frac{Fr_1 - Fr_4}{l_2 \cdot Kr}$ $\delta y = \frac{\sum_{j=1}^n F_{Yj}}{8 \cdot Ks} + X_d \cdot \frac{Fs_1 - Fs_4}{l_2 \cdot Ks} + Z_d \cdot \frac{Fr_1 - Fr_5}{l \cdot Kr}$ $\delta z = \frac{\sum_{k=1}^n F_{Zk}}{8 \cdot Kr} + X_d \cdot \frac{Fr_1 - Fr_4}{l_2 \cdot Kr} + Y_d \cdot \frac{Fr_1 - Fr_5}{l \cdot Kr}$

3. Calculation of dynamic equivalent load

- For the calculation of dynamic equivalent load, use the load in **Table 2.3** which matches the intended use of the linear guide.

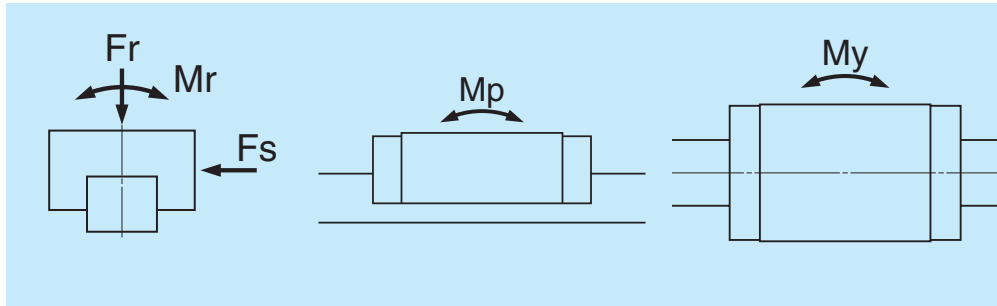

Fig. 2.2

Table 2.3 Loads in the arrangement of linear guides

Pattern	Arrangement of linear guide	Loads necessary to calculate dynamic equivalent load					Dynamic equivalent load
		Load		Moment load			
		Up/down (vertical)	Right/left (lateral)	Rolling	Pitching	Yawing	
1		F_r	F_s	M_r	M_p	M_y	$F_r = F_r$ $F_{se} = F_s \cdot \tan\alpha$
2		F_r	F_s	M_r			$F_{re} = \epsilon_r \cdot M_r$ $F_{pe} = \epsilon_p \cdot M_p$ $F_{ye} = \epsilon_y \cdot M_y$
3		F_r	F_s		M_p	M_y	α : Contact angle NH, VH, NS, LW, LH, HS Series $\alpha = 50^\circ$
4		F_r	F_s				PU, LU, PE, LE, RA, LA, HA Series $\alpha = 45^\circ$

- Use the dynamic equivalent coefficient ϵ in the table below for an easy conversion of moment loads to the dynamic equivalent load.

- The coefficient of each moment direction is as follows.
 - ϵ_r : Rolling direction
 - ϵ_p : Pitching direction
 - ϵ_y : Yawing direction

Table 2.4 Dynamic equivalent coefficients

Unit: 1/m

Model No.	ϵ_r	ϵ_p	ϵ_y	Model No.	ϵ_r	ϵ_p	ϵ_y	Model No.	ϵ_r	ϵ_p	ϵ_y
NH15	188	111	132	LW27	53	76	91	LH08	316	269	321
NH15L	188	72	86	LW35	32	51	61	LH10	253	203	242
NH20	142	81	97	LW50	25	38	46	LH12	223	136	162
NH20L	142	57	68								
NH25	123	68	81	PU05	377	431	431	RA15	105	95	95
NH25L	123	51	61	PU07	267	349	349	RA15L	105	70	70
NH30A	98	70	83	PU09	215	222	222	RA20	79	74	74
NH30EF	98	58	69	PU09L	215	136	136	RA20L	79	55	55
NH30L	98	44	52	PU12	163	204	204	RA25	71	64	64
NH35	78	51	61	PU12L	163	125	125	RA25L	71	50	50
NH35L	78	36	43	PU15	133	174	174	RA30	56	58	58
NH45	60	38	45	PU15L	133	102	102	RA30L	56	44	44
NH45L	60	30	36					RA35	46	52	52
NH55	51	31	37	LU05	385	359	359	RA35L	46	39	39
NH55L	51	25	30	LU07	286	305	305	RA45	37	40	40
NH65	43	27	32	LU09	217	242	242	RA45L	37	30	30
NH65L	43	20	24	LU09L	217	138	138	RA55	32	33	33
				LU09R	217	203	203	RA55L	32	24	24
VH15	188	111	132	LU12	167	204	204	RA65	26	28	28
VH15L	188	72	86	LU12L	167	116	116	RA65L	26	19	19
VH20	142	81	97	LU15	133	174	174				
VH20L	142	57	68	LU15L	133	94	94	LA25	122	76	76
VH25	123	68	81					LA25L	122	47	47
VH25L	123	51	61	PE05	194	277	277	LA30	105	63	63
VH30A	98	70	83	PE07	141	203	203	LA30L	105	43	43
VH30EF	98	58	69	PE09	123	161	161	LA35	84	54	54
VH30L	98	44	52	PE09L	123	108	108	LA35L	84	37	37
VH35	78	51	61	PE12	90	136	136	LA45	60	41	41
VH35L	78	36	43	PE12L	90	90	90	LA45L	60	31	31
VH45	60	38	45	PE15	50	111	111	LA55	51	33	33
VH45L	60	30	36	PE15L	50	72	72	LA55L	51	26	26
VH55	51	31	37					LA65	43	29	29
VH55L	51	25	30	LE05	196	248	248	LA65L	43	20	20
				LE05S	196	323	323				
NS15	177	116	138	LE07	141	188	188	HA25	122	33	33
NS15S	177	174	208	LE07S	141	349	349	HA30	105	27	27
NS20	127	94	112	LE07L	141	122	122	HA35	84	23	23
NS20S	127	136	162	LE09	123	149	149	HA45	60	20	20
NS25	111	70	83	LE09S	123	277	277	HA55	51	16	16
NS25S	111	108	129	LE09L	123	102	102				
NS30	94	63	75	LE12	90	125	125	HS15	177	45	54
NS30S	94	102	121	LE12S	90	233	233	HS20	127	39	47
NS35	76	54	64	LE12L	90	86	86	HS25	111	33	39
NS35S	76	87	104	LE15	50	102	102	HS30	94	27	32
				LE15S	50	174	174	HS35	76	23	28
				LE15L	50	68	68				
LW17	66	125	149								
LW21	59	108	129								

Definitions of codes appearing at the end of the model number in **Table 2.4**:

- L : Super-high-load type ; NH45L
- S : Medium load type ; NS25S
- No code: High-load type ; NH45_
- A : Ball slide shape is square ; NH30A (only NH30 and VH30)
- EF : Ball slide shape is flanged type (EL, FL type) ; NH30EF (only NH30 and VH30)
- R : Miniature Series with ball retainer ; LU09R (only LU and LE)

The formula is determined by the relationship of loads in terms of volume. A full dynamic equivalent load can be easily obtained by using each coefficient. After obtaining the dynamic equivalent load of the necessary load directions from **Table 2.4**, use the formulas below to calculate full dynamic equivalent loads.

- When F_r is the largest load : $F_e = F_r + 0.5F_{se} + 0.5F_{re} + 0.5F_{pe} + 0.5F_{ye}$
- When F_{se} is the largest load : $F_e = 0.5F_r + F_{se} + 0.5F_{re} + 0.5F_{pe} + 0.5F_{ye}$
- When F_{re} is the largest load : $F_e = 0.5F_r + 0.5F_{se} + F_{re} + 0.5F_{pe} + 0.5F_{ye}$
- When F_{pe} is the largest load : $F_e = 0.5F_r + 0.5F_{se} + 0.5F_{re} + F_{pe} + 0.5F_{ye}$
- When F_{ye} is the largest load : $F_e = 0.5F_r + 0.5F_{se} + 0.5F_{re} + 0.5F_{pe} + F_{ye}$

For the values of each dynamic equivalent load in the formulas above, disregard load directions and take the absolute value.

It is necessary to include the amount of preload for the calculation of rating life when selecting "Z3 medium preload" or "Z4 heavy preload" as a preload. For the calculation of full dynamic equivalent loads that consider preload, see "A-3-3 6" on page A31.

4. Calculation of mean effective load

When the load to the slide deviates, obtain a mean effective load which becomes equal to the life of slide under variable load conditions. If the load does not vary, use the dynamic equivalent load as it is.

(1) When load and running distance vary stepwise (Fig. 2.3)

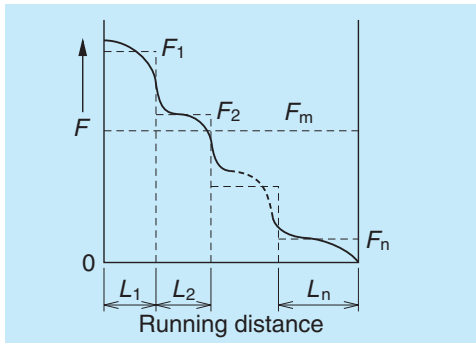

Fig. 2.3 Stepwise load change

- Running distance while dynamic equivalent load F_1 is applied: L_1
- Running distance while dynamic equivalent load F_2 is applied: L_2
- Running distance while dynamic equivalent load F_3 is applied: L_3
-
- Running distance while dynamic equivalent load F_n is applied: L_n

From the above, mean effective load F_m can be obtained by the following formula.

In case of ball
$$F_m = \sqrt[3]{\frac{1}{L} (F_1^3 L_1 + F_2^3 L_2 + \dots + F_n^3 L_n)}$$

In case of roller
$$F_m = \sqrt[10]{\frac{1}{L} (F_1^{10} L_1 + F_2^{10} L_2 + \dots + F_n^{10} L_n)}$$

F_m : Mean effective load of the deviating load (N)

L : Running distance (ΣL_n)

(2) When load changes almost linearly (Fig. 2.4)
Approximate mean effective load F_m can be obtained by the following formula.

$$F_m \doteq \frac{1}{3} (F_{min} + 2F_{max})$$

F_{min} : Minimum value of dynamic equivalent load (N)

F_{max} : Maximum value of dynamic equivalent load (N)

(3) When load changes in sinusoidal pattern (Fig. 2.5)

At time of (a): $F_m = 0.65 F_{max}$

At time of (b): $F_m = 0.75 F_{max}$

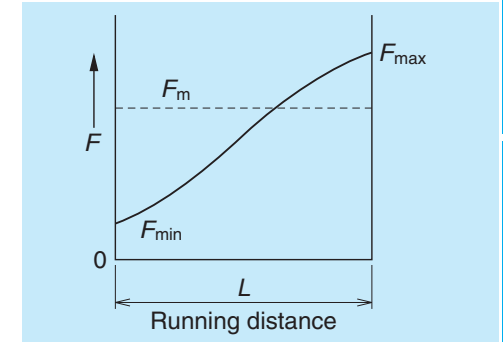

Fig. 2.4 Linear load change

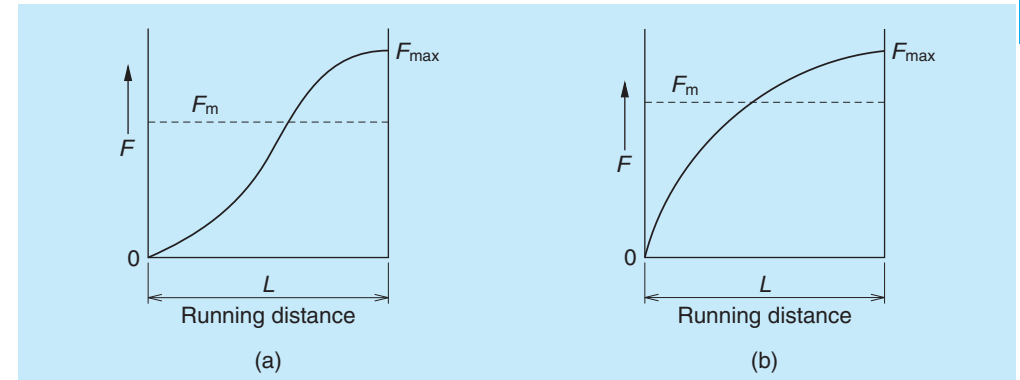

Fig. 2.5 Load that changes in sinusoidal pattern

5. Various coefficients

(1) Load factors

- Although a load applied to the slide can be calculated, the actual load becomes larger than the calculated value due to the machine's vibration and impact.
- Therefore, calculation of load on the slide should take into consideration the load factors in **Table 2.5**.

Table 2.5 Load factor f_w

Impact/Vibration	Load factor
No external impact/vibration	1.0 – 1.5
There is impact/vibration from outside.	1.5 – 2.0
There is significant impact/vibration.	2.0 – 3.0

(2) Hardness coefficient

- For linear guides, in order to function optimally, both the rolling elements and the rolling contact surface must have a hardness of HRC58 to 62 to an appropriate depth.
- The hardness of NSK linear guide fully satisfies HRC58 to 62. Therefore, in most cases it is not necessary to consider hardness. If the linear guide is made of a special material by a customer's request, as the material hardness is lower than HRC58, use the following formula for adjustment.

$$C_H = f_H \cdot C$$

$$C_{OH} = f_{H'} \cdot C_0$$

- C_H : Basic dynamic load rating adjusted by hardness coefficient
- f_H : Hardness coefficient (Refer to Fig. 2.6)
- C_{OH} : Basic static load rating adjusted by hardness coefficient
- $f_{H'}$: Static hardness coefficient (Refer to Fig. 2.6)

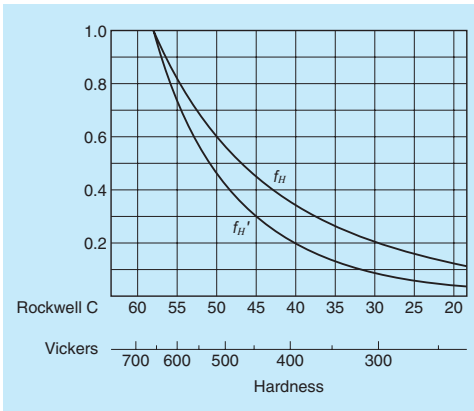

Fig. 2.6 Hardness coefficient

(3) Reliability coefficient

- In general, a reliability of 90% is customary. In this case, reliability coefficient is 1. Therefore, the reliability coefficient does not have to be included in calculation.

6. Calculation of rating life

(1) Life Calculating Formula

The life calculating formula in the stroke movement with normal lubrication, the following relationships exist between the slide mean effective load F_m (N), the basic dynamic load rating to load application direction C (N), and the rating fatigue life L (km).

[For balls as rolling element]

For the basic dynamic load rating for 100 km

$$L = 100 \times \left(\frac{f_H \cdot C_{100}}{f_w \cdot F_m} \right)^3$$

For the basic dynamic load rating for 50 km

$$L = 50 \times \left(\frac{f_H \cdot C_{50}}{f_w \cdot F_m} \right)^3$$

[For rollers as rolling element]

For the basic dynamic load rating for 100 km

$$L = 100 \times \left(\frac{f_H \cdot C_{100}}{f_w \cdot F_m} \right)^{\frac{10}{3}}$$

For the basic dynamic load rating for 50 km

$$L = 50 \times \left(\frac{f_H \cdot C_{50}}{f_w \cdot F_m} \right)^{\frac{10}{3}}$$

- L : Rating fatigue life (km)
- C_{100} : Basic dynamic load rating for 100 km rated fatigue life (N)
- C_{50} : Basic dynamic load rating for 50 km rated fatigue life (N)
- f_H : Hardness coefficient
- f_w : Load coefficient
- F_m : Average load (N)

Note: Do not use the basic static load rating C_0 and the basic static moment rating M_{Ro} , M_{Po} or M_{Yo} for a calculation of the life.

(2) Life as an entire guide way system

In those cases when several slides comprise a single guide way system (such as a single-axis table), the life of the slide to which the most strenuous condition is applied is considered to be the life of the entire system.

For example, in Fig. 2.7, if "slide A" is the slide which receives the largest mean effective load, or if "slide A" is the one which has the shortest life, the life of the system is considered to be the life of "slide A."

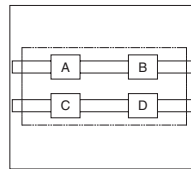

Fig. 2.7 Life of a system

7. Examination of the basic static load rating

(1) Examine from the basic static load rating

- Examine the static equivalent load P_0 , which is applied to the slide, from the basic static load rating C_0 and the static permissible load factor f_s .

$$f_s = \frac{C_0}{P_0}$$

When the static equivalent load P_0 is a combination of vertical loads Fr and lateral load Fs , calculate it using formulas below.

For NH, VH, NS, LW, LH and HS Series:

If compressed load and lateral load are combined

$$P_0 = Fr + 1.54Fs$$

If tensile load and lateral load are combined

$$P_0 = 1.28Fr + 1.54Fs$$

For PU, LU, PE, LE, LL, RA, LA and HA Series:

$$P_0 = Fr + Fs$$

- The table below shows guidelines of f_s for general industrial use.

Table 2.6

Use conditions	f_s
Under normal operating conditions	1 - 2
Operating under vibration/impact	1.5 - 3

- Basic static load rating is not a destructive force to the balls, rollers, rails, or slides. The balls can withstand a load more than seven times larger than the basic static load rating. It is sufficient as a safety factor to the destruction load designed for general machines.
- However, when a heavy load applied to the rail and slide in tension direction, the strength of the bolts which secures the rail and the ball slide affects the strength of the entire system. Strength of the bolt and its material should be considered.

(2) Examining from static moment load rating

- Also examine the static permissible moment load M_s from the basic static moment load M_{Po} and the static permissible load factor f_s .

$$f_s = \frac{M_{Po}}{M_s}$$

If more than one moment load in any direction is combined, please consult NSK.

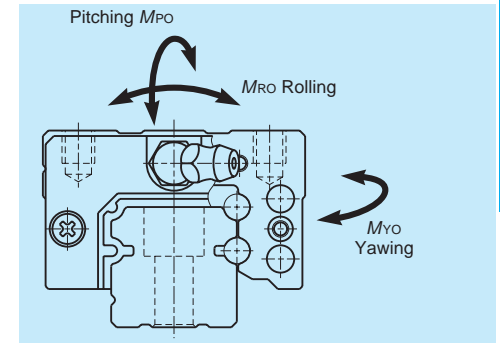

Fig. 2.8 Moment load directions

8. Precautions for the design in examining the life

The following points must be heeded in examining the life.



In case of oscillating motion

- If the rolling elements do not rotate all the way, but only halfway, and if this minute stroke is repeated, lubricant disappears from the contact surface of rolling elements and raceways. This generates "fretting," a premature wear. Fretting cannot be entirely prevented, but it can be mitigated.
- A grease which prevents fretting is recommended for oscillating stroke operations. When a standard grease is used, the life can be markedly prolonged by adding a normal stroke travel (about the slide length) once every several thousand cycles.



When applying pitching or yawing moment

- The load applied to the rolling element rows inside the slide is inconsistent if a pitching or yawing moment load is applied. Loads are heavy on the rolling elements on each end of the row.
- In such case, a heavy load lubricant grease or oil are recommended. Another countermeasure is using one size larger model of linear guide to reduce the load per rolling element.
- The moment load to a ball slide is insignificant for 2-rail, 4-slide combination which is commonly used.



When an extraordinary high load is applied during stroke

- If an extraordinary large load is applied at certain position of the stroke, calculate not only the life based on the mean effective load, but also the life based on the load in this range.
- When an extraordinary heavy load is applied and thus the application of high tensile stress to fixing bolts of the rails and slides is foreseen, the strength of the bolts should be considered.



When the calculated life is extraordinarily short (Less than 3 000 km in calculated life)

- In such case, the contact pressure to the rolling elements and the rolling contact surface is extraordinarily high.
- If the linear guides are operated under such state continually, the life is significantly affected by the loss of lubrication and the presence of dust, and thus the actual life becomes shorter than calculated.
- It is necessary to reconsider the arrangement of linear guides, the number of slide, and the type of model in order to reduce the load to the slides.
- It is necessary to consider preload for calculation of rating life when selecting Z3 (medium preload) or Z4 (heavy preload) as a preload. For the calculation of full dynamic equivalent loads that consider preload, see "A-3-3 6" on page A31.



Application at high speed

- The standard maximum allowable speed of a linear guide under normal conditions is 100 m/min. However, the maximum allowable speed can be affected by accuracy of installation, operating temperature, external loading etc.
- The end cap with high speed specification must be used when the operating speed exceeds the permissible speed. In such a case, please consult NSK.

A-3-3 Preload

1. Objective of preload

- An elimination of clearance between the raceways and rolling elements vanishes the mechanical play of the linear guide system.
- When a preload is applied, the deformation of linear guides by external vertical load is further improved thus increasing the system stiffness.
- Preloading method

The preload is applied by inserting rolling elements slightly bigger than the space of two raceways as shown in Fig. 3.1.

2. Preload and rigidity

- In NSK linear guides, slight size changes of rolling elements, which are going to be inserted in the slide, control the clearance and amount of preload.
- In NSK linear guides, the rigidity is further increased and the elastic deformation is reduced by applying preload.
- In general, the load range of ball guide system in which the preload is effective, is about 2.8 times of the preload (Fig. 3.2). For roller guide system, it becomes about 2.2 times of the preload.
- Fig. 3.3 shows the relationship between the ball slide deformation and the external vertical load under a specified preload. NH35 is used as an example.
- The following show the definition of linear guide rigidity.
 - (1) Radial rigidity: Rigidity of vertical and lateral directions, up/down and right/left (Fig. 3.4).
 - (2) Moment rigidity: Three moment directions, pitching, rolling, and yawing (Fig. 3.5).

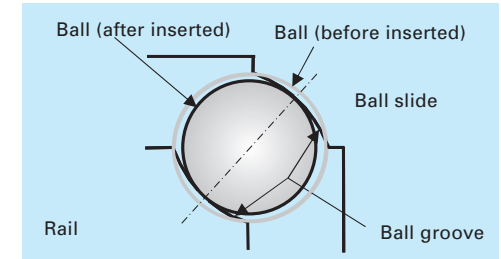

Fig. 3.1 Preloading method

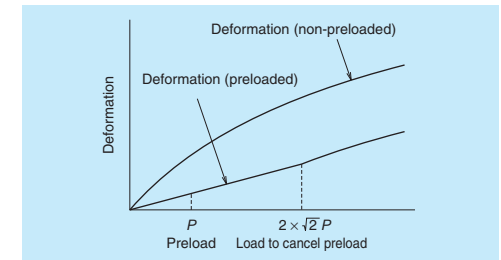

Fig. 3.2 Elastic deformation

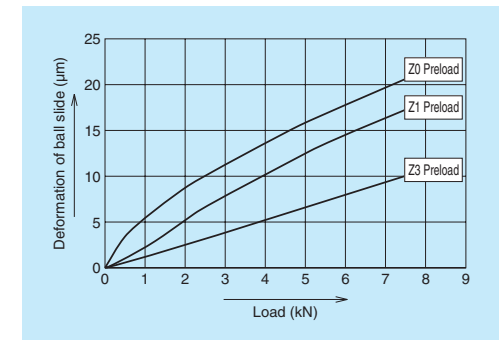

Fig. 3.3 Rigidity of NH35, downward direction load (example)

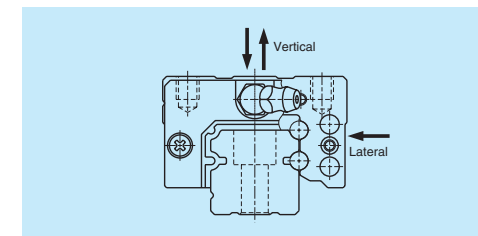

Fig. 3.4 Radial rigidity

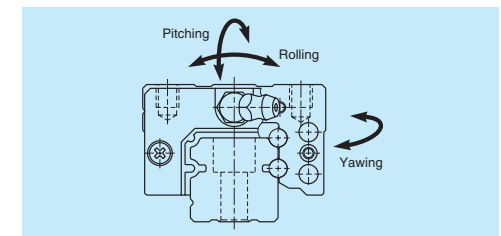

Fig. 3.5 Moment rigidity

- Since two rails and four slides are used in general as a pair, consideration only for the radial rigidity is sufficient.
- However, in cases as shown in **Fig. 3.6**, **Fig. 3.7** and **Fig. 3.8**, it is necessary to take into account the moment rigidity in addition to the radial rigidity.

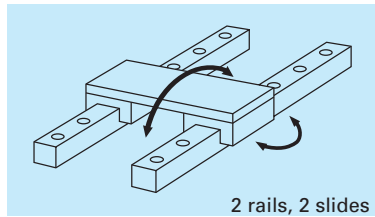

Fig. 3.6 Pitching and yawing direction

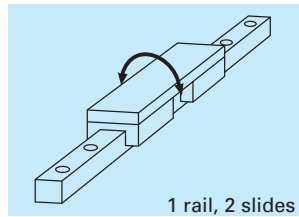

Fig. 3.7 Rolling direction

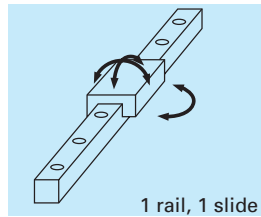

Fig. 3.8 All directions

3. Selection of preload classification

- Several types of preload that match the characteristic of each series are set for NSK linear guides.
- Types of preload classification for each series are shown in **Table 3.1**. **Table 3.2** shows the selection criterion of the preload classification.

Table 3.1 Classification of preload in each series

Preload Series	Preloaded assembly (not random matching)				Random-matching type		
	Heavy preload Z4	Medium preload Z3	Slight preload Z1	Fine clearance Z0	Medium preload ZH	Slight preload ZZ	Fine clearance ZT
Ball guide	NH, NS	○	○	○	○	○	○
	VH	○	○	○		○	○
	LW	(○)	○	○		○	○
	PU		○	○		○	○
	LU			○			○
	PE			○			○
	LE			○			○
	Miniature LH			○			○
	LL						○
	LA	○	○				
Roller guide	HA		○				
	HS		○	○			
	RA		○	○	○	○	

Table 3.2 Selection criterion of the preload

Classification of preload	Use condition	Applications
Z0 and ZT (Fine clearance)	<ul style="list-style-type: none"> • An application in which a set of two parallel linear guides (four slides/two rails) is used to sustain a unidirectional load with low vibration and impact. • An application in which the accuracy is not very necessary but a friction force must be minimized. 	Welding machines, Glass processing machines, Packaging/packing machines, Materials handling equipment
Z1 and ZZ (Slight preload)	<ul style="list-style-type: none"> • Moment loads are applied. • Application for a highly accurate operation. 	Industrial robots, Inspection/measuring equipment, Laser cutting machine, Electric discharge machines, PCB drillers, Chip mounters
Z3, ZH, and Z4 (Medium preload, Heavy preload)	<ul style="list-style-type: none"> • Application in which extremely high stiffness is essential. • Application in which vibration and impact load will be applied. 	Machining centers, Lathes, Milling machines, Boring machines, Grinders

4. Estimation of the elastic deformation

The followings are the relation between load and deformation.

- Without the preload
 - When the rolling element is ball
 - The deformation is proportional to the 2/3 power of the load.
 - When the rolling element is roller
 - The deformation is proportional to the 9/10 power of the load.
- With the preload
 - The deformation is directly proportional to the load.

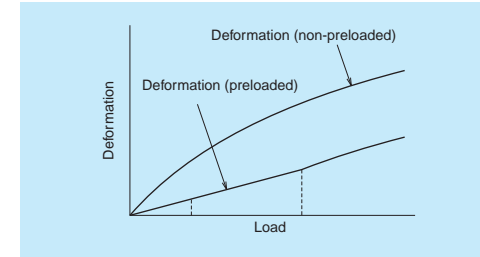

Fig. 3.9 Elastic deformation

A preloaded linear guide deforms proportionally to the load as shown in **Fig. 3.9**; the calculation of system deformation can be done using the deformation curve. The factors required for an estimation of the system deformation are listed below. The stiffness of slide is shown on the relevant explanation of each linear guide series.

<Required conditions to calculate deformation>

- Volume of load
- Direction of load
- Point of load application
- Position of deformation calculation
- Arrangement of rails and ball slides
- Position of a driving mechanism

Please refer to the calculation formula of deformation for typical table structures on the pages A18 to A20.

5. Application examples of preload

Table 3.3 shows typical application for each preload types of the NSK linear guides.

Refer to this table when selecting the preload type for your application.

Table 3.3 Application examples of preload

Type of machine	Application	Preload			
		Heavy preload Z4	Medium preload Z3, ZH	Slight preload Z1, ZZ	Fine clearance Z0, ZT
Machine tools	• Machining centers	○	○		
	• Grinders	○	○		
	• Lathes	○	○		
	• Milling machines	○	○		
	• Drilling machines	○	○		
	• Boring machines		○		
	• Gear cutters	○	○		
	• Diesinking machines		○	○	
	• Laser cutting machines		○	○	
	• Electric discharge machines		○		
Industrial machines and equipment	• Punch presses		○	○	
	• Press machines			○	○
	• Welding machines		○	○	○
	• Painting machines			○	○
	• Textile machines			○	○
	• Coil winders		○	○	
	• Woodworking machines		○	○	○
	• Glass processing machines			○	○
	• Stone cutting machines			○	○
	• Tire forming machines			○	○
Semiconductor facilities	• ATC			○	○
	• Industrial robots		○	○	○
	• Materials handling equipment			○	○
	• Packing machines			○	○
	• Construction machines				○
	• Probers		○		
	• Wire bonders		○	○	
	• PCB drillers		○	○	
	• Wafer slicers		○		
	• Wafer dicers		○		
Others	• Chip mounters		○	○	
	• IC handlers			○	
	• Scanners			○	
	• Lithographic machines		○	○	
	• Measuring/inspection equipment			○	
	• Three-dimensional measuring equipment		○	○	
	• Medical equipment			○	○
	• OA equipment			○	○
	• Railway cars			○	○
	• Stage systems				○
• Pneumatic equipment			○	○	

6. Load and rating life when the preload is taken into account

• It is necessary to include the amount of preload for the calculation of rating life when the Z3 (medium preload) or the Z4 (heavy preload) preload type is specified.

• Full dynamic equivalent load when the preload is taken into account can be obtained by the following formulas.

For balls as rolling element

$$F_{e_p} = P \left(1 + \frac{F_e}{2.83 \times P} \right)^{\frac{3}{2}}$$

P: Preload (N)

However, when the full dynamic equivalent load taking account of preload is larger than the load at which preload is removed, $F_{e_p} = F_e$.

For this case, preload is lost at $F_{p0} = 2^{\frac{3}{2}} P$

For rollers as rolling element

$$F_{e_p} = P \left(1 + \frac{F_e}{2.16 \times P} \right)^{\frac{10}{9}}$$

P: Preload (N)

However, when the full dynamic equivalent load taking preload into account is larger than the load at which preload is removed, $F_{e_p} = F_e$.

For this case, preload is lost at $F_{p0} = 2^{\frac{10}{9}} P$

7. Calculating friction force by preload

- Dynamic friction force per one slide of the ball guide can be calculated from a preload value.
- The following is a simple calculation to obtain the criterion of dynamic friction force.

For the slight preload ZZ of a preloaded random-matching type linear guide, use the preload volume of slight preload Z1 type assembly.

$$F = iP$$

F : Dynamic friction force (N)

P : Preload (N)

i : Contact coefficient

Use the following contact coefficient values (*i*) for each series of linear guides.

NH, VH, NS, LW, LH and HS Series

: 0.004

LA and HA Series

: 0.010

PU, LU, PE and LE Series

: 0.026

- The starting friction force when the slide begins to move depends on lubrication condition. Roughly estimate it at 1.5 to 2 times of the dynamic friction obtained by the above method.

Calculation example

In case of NH35AN - Z3

$i = 0.004$

$P = 2\,350$ (N) (refer to NH series preload)

$F = iP$

$= 0.004 \times 2\,350 = 9.4$ (N)

Therefore, the criteria of the dynamic friction force of NH35AN - Z3 is 9.4 N.

For seal friction, refer to seal friction of each Series.

A-3-4 Accuracy

1. Accuracy standard

The accuracy characteristics of linear guide are specified to each series in the variations of assembled height, assembled width, and running parallelism. We also specify the mutual variation of a pair of linear guides in the assembled height and assembled width. The accuracy of the table equipped with a set of linear guides is depending on other accuracies and many factors besides the accuracy of linear guides. Those are the accuracy of the mounting surface of the machine, the mounting span between two linear guides, the span of ball slides, the number of ball slides, and the location of the point at where the accuracy is really required. The NSK linear guides can deal with these factors and provide the best suited model for your specific application.

2. Definition of accuracy

- Table 4.1, Fig. 4.1 and Fig. 4.2 show accuracy characteristics.

Table 4.1 Definition of accuracy

Characteristics	Definition (Figs. 4.1 and 4.2)
Mounting height <i>H</i>	Distance from A (rail bottom datum surface) to C (slide top surface)
Variation of <i>H</i>	Variation of <i>H</i> in slides assembled to the rails of a set of linear guides
Mounting width <i>W₂</i> or <i>W₃</i>	Distance from B (rail side datum surface) to D (slide side datum surface). Applicable only to the reference linear guide.
Variation of <i>W₂</i> or <i>W₃</i>	Difference of the width (<i>W₂</i> or <i>W₃</i>) between the assembled slides which are installed in the same rail. Applicable only to the reference linear guide.
Running parallelism of slide, surface C to surface A	Variation of C (slide top surface) to A (rail bottom datum surface) when slide is moving.
Running parallelism of slide, surface D to surface B	Variation of D (slide side datum surface) to B (rail side datum surface) when a slide is moving.

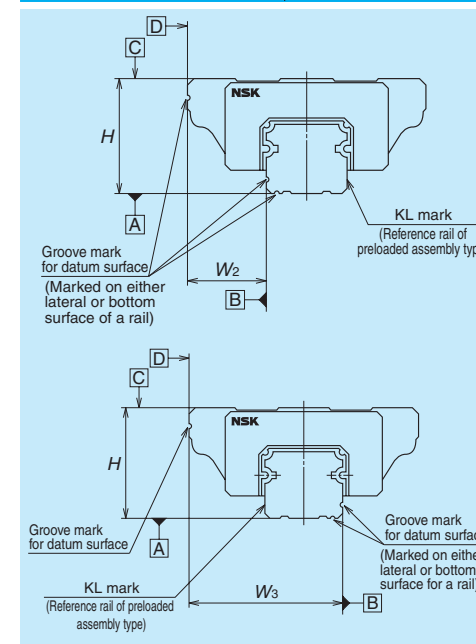

Fig. 4.1 Assembled dimensions

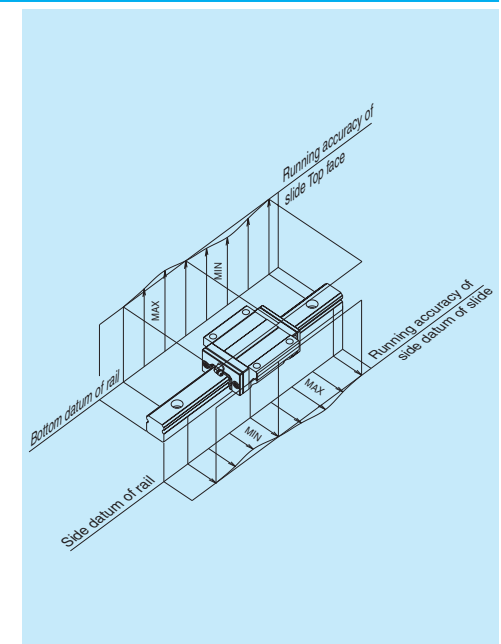

Fig. 4.2 Running parallelism of slide

Mounting width: W_2 and W_3

- Mounting width differs depending on the arrangement of the datum surfaces of the rail and slide on the reference linear guide (indicated as KL on the rail). (Fig. 4.3 and Fig. 4.4)

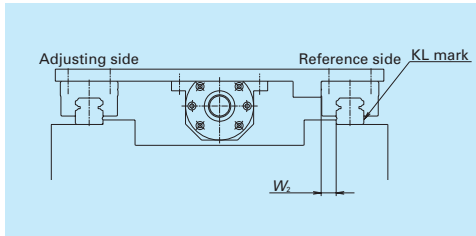

Fig. 4.3 Mounting width W_2

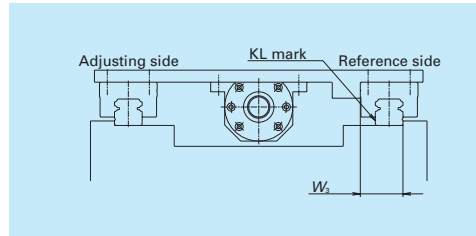

Fig. 4.4 Mounting width W_3

Running Parallelism of Slide

- Running parallelism of slide is common in all series. Specifications of all accuracy grades are shown in Table 4.2. However, applicable accuracy grades differ by series. Please refer to "Table 4.4 Accuracy grade and applicable series" on page A35.

Table 4.2 Running parallelism of slide

Unit: μm

Accuracy grade	Preloaded assembly (not random matching)						Random-matching type		
	Ultra precision P3		Super precision P4	High precision P5	Precision grade P6	Normal grade PN	High precision PH	Normal grade PC	
	over	or less							
	–	50	2	2	2	4.5	6	2	6
	50	– 80	2	2	3	5	6	3	6
	80	– 125	2	2	3.5	5.5	6.5	3.5	6.5
	125	– 200	2	2	4	6	7	4	7
	200	– 250	2	2.5	5	7	8	5	8
	250	– 315	2	2.5	5	8	9	5	9
	315	– 400	2	3	6	9	11	6	11
	400	– 500	2	3	6	10	12	6	12
	500	– 630	2	3.5	7	12	14	7	14
	630	– 800	2	4.5 (4)	8	14	16	8	16
	800	– 1 000	2.5	5 (4.5)	9	16	18	9	18
	1 000	– 1 250	3	6 (5)	10	17	20	10	20
	1 250	– 1 600	4	7 (6)	11	19	23	11	23
	1 600	– 2 000	4.5	8 (7)	13	21	26	13	26
	2 000	– 2 500	5	10 (8)	15	22	29	15	29
	2 500	– 3 150	6	11 (9.5)	17	25	32	17	32
	3 150	– 4 000	9	16	23	30	34	23	34

Note: Value of () is the running parallelism of RA Series.

3. Application examples of accuracy grade and preload

Table 4.3 shows examples of accuracy grade and preload of NSK linear guides for specific purposes. Refer to this table when selecting accuracy grade and preload type for your application.

Table 4.3 Application examples of accuracy grade and preload

Type of machine	Application	Accuracy grade				Preload				
		Ultra precision P3	Super precision P4	High precision P5, PH	Precision grade P6	Normal grade PN, PC	Heavy preload Z4	Medium preload Z3, ZH	Slight preload Z1, ZZ	Fine clearance Z0, ZT
Machine tools	• Machining centers		○	○	○		○	○		
	• Grinders	○	○	○			○	○		
	• Lathes		○	○	○		○	○		
	• Milling machines		○	○	○		○	○		
	• Drilling machines			○	○		○	○		
	• Boring machines		○	○	○		○	○		
	• Gear cutters		○	○	○		○	○		
	• Diesinking machines		○	○	○			○	○	
	• Laser cutting machines		○	○	○			○	○	
	• Electric discharge machines	○	○	○			○	○		
Industrial machines and equipment	• Punch presses			○	○			○	○	
	• Press machines				○			○	○	○
	• Welding machines							○	○	○
	• Painting machines				○			○	○	○
	• Textile machine				○			○	○	○
	• Coil winders				○			○	○	○
	• Woodworking machines			○	○			○	○	○
	• Glass processing machines				○			○	○	○
	• Stone cutting machines				○			○	○	○
	• Tire forming machines				○			○	○	○
	• ATC				○			○	○	○
	• Industrial robots			○	○			○	○	○
	• Materials handling equipment				○			○	○	○
• Packing machines				○			○	○	○	
• Construction machines				○			○	○	○	
Semiconductor facilities	• Probers	○						○	○	
	• Wire bonders		○	○				○	○	
	• PCB drillers			○	○			○	○	
	• Wafer slicers	○	○					○	○	
	• Wafer dicers	○	○					○	○	
	• Chip mounters			○	○			○	○	
	• IC handlers			○	○			○	○	
	• Scanners			○	○			○	○	
	• Lithographic machines	○	○					○	○	
	• Measuring/inspection equipment	○	○	○	○			○	○	
Others	• Three-dimensional measuring equipment	○	○	○	○			○	○	
	• Medical equipment		○	○	○			○	○	○
	• OA equipment				○			○	○	○
	• Railway cars				○			○	○	○
	• Stage systems				○			○	○	○
• Pneumatic equipment				○	○		○	○	○	

Note: Only Z1 and Z0 are available for PN grade.

For random-matching type, preload "ZH" and "ZZ" are available for PH grade. For PC grade, "ZH", "ZZ" and "ZT" are available.

4. Combination of accuracy grade and preload

(1) Accuracy grades

- The accuracy grade which matches the characteristic of each series is set for the NSK linear guides.
- Table 4.4** shows the accuracy grades available for each series.
- Refer to "**3. Application examples of accuracy grade**" which shows cases of appropriate accuracy grade for specific purpose.

Table 4.4 Accuracy grades and applicable series

Series	Preloaded assembly (not random matching)					Random-matching type	
	Ultra precision	Super precision	High precision	Precision grade	Normal grade	High precision	Normal grade
	P3	P4	P5	P6	PN	PH	PC
NH, NS	○	○	○	○	○	○	○
VH	○	○	○	○	○		○
LA	○	○	○	○			
LW			○	○	○		○
PE, LE		○	○	○	○		○
PU, LU		○	○	○	○		○
Miniature LH		○	○	○	○		
LL					○		
HA	○	○	○				
HS	○	○	○				
RA	○	○	○	○		○*	

*) Only RA25 to RA65 are available in random matching.

(2) Preload

- Several classifications of preload that match the characteristic of each series are set for the NSK linear guides.
- The classification of preload for each series are shown in **Table 4.5**.
- Refer to the specifications of each series for details of radial clearance, preload, and rigidity.
- "**3. Application examples of accuracy grade**" shows the cases of appropriate preload classifications and accuracy grades for specific purposes.

Table 4.5 Classification of preload

Series	Preloaded assembly (not random matching)				Random-matching type		
	Heavy preload	Medium preload	Slight preload	Fine clearance	Medium preload	Slight preload	Fine clearance
	Z4	Z3	Z1	Z0	ZH	ZZ	ZT
NH, NS		○	○	○	○	○	○
VH		○	○	○		○	○
LA	○	○					
LW		(○)	○	○		○	○
PE, LE			○	○			○
PU, LU			○	○			○
Miniature LH			○	○			
LL				○			
HA		○	○				
HS		○	○				
RA		○	○		○	○	

Notes: 1) Z3 preload classification is only applicable to LW35 and LW50 for LW Series.

2) Only RA25 to RA65 are available in random matching.

3) The preload code of "Z" is omitted from the specification number. Only the number of preload classification code is specified on the last code of the reference number. (Refer to the reference number of each series.)

(3) Combinations of accuracy grade and preload

- Combinations of accuracy grade and preload are shown in **Table 4.6**.

Table 4.6 Combinations of accuracy grade and preload type

	Accuracy grade		Preload
	Preloaded assembly	P3 – P6	
PN		Z1, Z0	
Random-matching type	PC, PH ^{*1, *2}		ZH, ZZ, ZT

*1) The random-matching type is available for the models of RA25 to RA65. PH grade is set for the accuracy.
 *2) ZH and ZZ preload are available for the PH accuracy grade.

A-3-5 Maximum Rail Length

General Industrial Use

Unit: mm

Series	Material	Size							
		15	20	25	30	35	45	55	65
NH	Special high carbon steel	2 980	3 960	3 960	4 000	4 000	3 990	3 960	3 900
	Stainless steel	1 800	3 500	3 500	3 500				
VH	Special high carbon steel	2 000	3 960	3 960	4 000	4 000	3 990	3 960	
	Stainless steel	1 800	3 500	3 500	3 500				
NS	Special high carbon steel	2 920	3 960	3 960	4 000	4 000			
	Stainless steel	1 800	3 500	3 500	3 500	3 500			

Unit: mm

Series	Material	Size				
		17	21	27	35	50
LW	Special high carbon steel	1 000	1 600	2 000	2 000	2 000

Liquid Crystal Display and Semiconductor

Unit: mm

Series	Material	Size						
		05	07	08	09	10	12	15
PU	Stainless steel	210	375		600		800	1 000
LU	Special high carbon steel				1 200		1 800	2 000
	Stainless steel	210	375		600		800	1 000
PE	Stainless steel	150	600		800		1 000	1 200
LE	Stainless steel	150	600		800		1 000	1 200
LH	Stainless steel			375		600	800	

Machine Tools

Unit: mm

Series	Material	Size							
		15	20	25	30	35	45	55	65
RA	Special high carbon steel	2 000	3 000	3 900	3 900	3 900	3 650	3 600	3 600
LA	Special high carbon steel			3 960	4 000	4 000	3 990	3 960	3 900

High-Precision Machine and High-Precision Measuring Equipment

Unit: mm

Series	Material	Size						
		15	20	25	30	35	45	55
HA	Special high carbon steel			3 960	4 000	4 000	3 990	3 960
HS	Special high carbon steel	2 000	3 960	3 960	4 000	4 000		
	Stainless steel	1 800	3 500	3 500	3 500	3 500		

A-3-6 Lubrication

1. NSK linear guides equipped with "NSK K1™" lubrication unit



NSK K1 lowers machine operation cost, and reduces impact on the environment.

What is "long-term, maintenance-free" operation?
 Ball screws and linear guides which are equipped with NSK K1 do not require maintenance for five years or up to 10 000 km operational distance.

What is NSK K1 lubrication unit?
 NSK K1 is a lubrication device which combines oil and resin in a single unit. The porous resin contains a large amount of lubrication oil. Touching its surface to the raceway of a rail close to the ball contact point NSK K1 constantly supplies fresh oil which seeps from the resin.

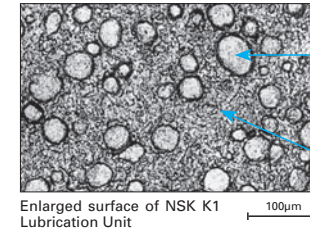

Polyolefin
 Unlike vinyl chloride products, polyolefin does not produce dioxin. Polyolefin is also being used increasingly at supermarkets for food wrapping.

Lubrication oil
 It is mineral oil-based lubricant. The oil has a viscosity of 100 cSt.

Remarkable capacity with new material:

NSK K1™ lubrication unit information

- A NSK K1 lubrication unit (referred to as NSK K1 hereafter) equipped with an NSK linear guide is an outstanding new lubrication material.
- A Newly developed porous synthetic resin contains large volume of lubricant oil that seeps out and enhances lubricating function.
- Simply install NSK K1 inside a standard end seal (rubber).
- We also provide NSK K1 lubrication unit for sanitary environments suited for food processing machinery, medical equipment and their ancillaries for the environment where hygiene control is essential. For details, refer to "A-3-9 3. NSK Linear Guides for Food Processing Equipment and Medical Devices for Sanitary Environment".

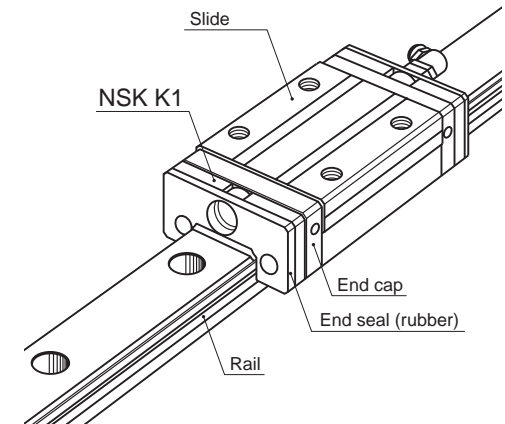

Fig. 6.1

(1) Features

NSK K1 comprises a part of the compact and efficient lubrication unit.

1) Maintenance is required only infrequently

Used with grease, the lubrication function lasts for a long time. Ideal for systems/environments in which replenishing is difficult.

For automotive component processing lines, etc.

2) Does not pollute the environment

A very small volume of grease combined with NSK K1 can provide sufficient lubrication in the environment where grease is undesirable as well as in the environment where high cleanliness is required.

Food processing/medical equipment, liquid crystal displays/semiconductor manufacturing equipment, etc.

We also provide NSK K1 lubrication unit for sanitary environment suited for food processing machinery, medical equipment and their ancillaries for the environment where hygiene control is essential. For details, refer to "A-3-9 3. NSK Linear Guides for Food Processing Equipment and Medical Devices for Sanitary Environment".

(2) Functions

NSK K1 has various superb functions. NSK's ample test data and field performances confirm NSK K1 abilities.

1) Durability test at high speed, with no other lubrication

Fig. 6.2 shows test results under these conditions. The linear guide operated with no lubricant is unable to travel after a short period because breakage occurs. Equipped with NSK K1, the linear guide easily travels 25 000 km.

Conditions: Sample ; LH30AN (preload Z1)
Travel speed ; 200 m/min

3) Good for applications where lubricant is washed away

Used with grease, life of the machine is prolonged even when the machine is washed entirely by water, or in an environments where the machine is exposed to rain or wind.

Food processing equipment, housing/construction machines, etc.

4) Maintains efficiency in dusty environments

In environments where oil- and grease-absorbing dust is produced, long-term efficiency in lubrication and prevention from foreign inclusions is maintained by using NSK K1 in combination with grease.

Woodworking machines, etc.

*Stainless steel linear guides are available for use in corrosive environments or other environments where rusting is a potential problem.

Stroke ; 1 800 mm
No lubricant: Completely degraded, no lubrication
NSK K1: Completely degraded, no lubrication + NSK K1

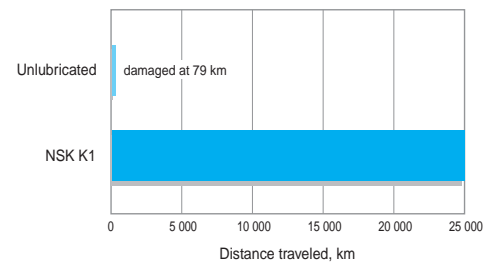

Fig. 6.2 Durability test at high speed, with no lubrication (lubricated by NSK K1 only)

2) Immersion test

Fig. 6.3 shows the test results after a linear guide is immersed in water once per week for 24 hours at a time, then traveled for 2 700 km. Without NSK K1, the ball groove surface wore out at an early stage and broke. With NSK K1, the wear was reduced to about 1/3 (Table 6.1). This test proves the effect of NSK K1.

Conditions: Sample ; LS30 Stainless steel (preload Z1)
Travel speed ; 24 m/min
Stroke ; 400 mm
Load ; 4 700 N/Slide
Lubricant ; Fully packed with grease (* exclusive use for food processing machines)

Immersing condition: Immersed and traveled once per week for 24 hours at a time.

* Grease made in U.S.A.

Characteristic
Consistency: 280
Base oil viscosity: 580 (cSt)

Table 6.1 Comparison in wear of grooves and steel balls (2 700 km)

Lubricating condition	Ball slide groove	Rail groove	Steel balls
With NSK K1	16 – 18	2 – 3	6 – 8
Without NSK K1	30 – 45	9 – 11	17 – 25

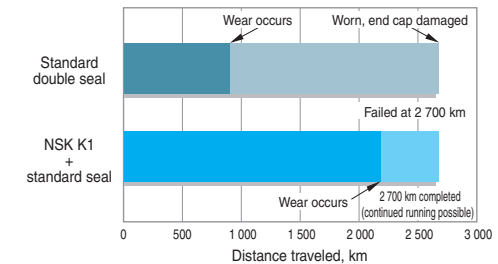

Fig. 6.3 Durability test immersed in water

4) Dust generation

Fig. 6.5 is a comparison of dust generation of NSK K1. The combination of NSK K1 and NSK Clean Grease LG2 (low dust generation grease) generates as little dust as fluorine grease (vacuum grease).

Conditions: Sample ; LS20
Travel speed ; 36 m/min

3) Durability test with wood chips

Wood chips absorb lubricant. Maintaining lubrication in such environment is extremely difficult. Fig. 6.4 shows that the life when NSK K1 is added to a standard seal is two times longer than the life when two seals are combined (standard double seal).

Conditions: Sample ; LH30AN (preload Z1)
Travel speed ; 24 m/min
Stroke ; 400 mm
Load ; 490 N/Slide

Seal specifications/lubricant:
Standard double Seal...Standard double Seal + AS2 Grease
NSK K1.....NSK K1 + Standard seal + AS2 Grease

Wood chip conditions:
1..... Volume of wood chips: Large
2..... Volume of wood chips: Medium

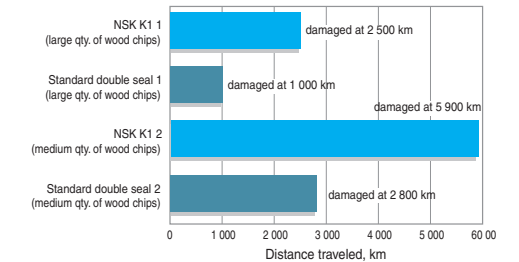

Fig. 6.4 Durability test with wood chips

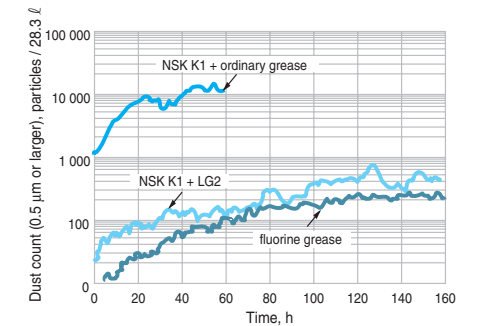

Fig. 6.5 Comparison of dust emission

(3) Specifications

1) Applicable series and sizes

- a) Can be installed in NH, NS, LW, PU, LU, PE, LE, LH, RA, LA, HA, and HS series. It is standard equipment for the VH Series.
- b) Can be used with stainless steel materials and surface-treated items.

2) Standard specifications

- a) NSK K1 is installed between the end seal and end cap.
(Double-seal specification, and specification with protector are also available upon request.)
- b) NSK standard grease is packed inside the slide.
(You may specify the type of grease and its volume if required.)
- c) Accuracy and preload classifications are the same as standard items. (Dynamic friction increases slightly due to NSK K1.)

3) Number of installed NSK K1

Normally, one NSK K1 should be installed on both ends of slides. (two K1s for one slide)
However, more NSK K1 may be required under more stringent operating conditions and environment. Please consult NSK for details in such a case.

Precautions for handling

To maintain high functionality of the NSK K1, observe the following precautions.

- Temperature range for use: Maximum temperature in use: 50°C
Momentary maximum temperature in use: 80°C
- Chemicals that should not come into contact with NSK K1:
Do not leave the NSK K1 in an organic solvent, such as hexane and thinner that remove oil, or rust preventive oil that contains white kerosene.

Note: Water-type cutting oil, oil-type cutting oil, mineral-oil type grease and ester-type grease do not damage NSK K1.

2. Lubrication

Mainly there are two ways of lubrication, grease and oil, for linear guides.

Use a lubricant agent and method most suitable to condition requirements and the purpose to optimize functions of linear guides.

In general, lubricants with low base oil kinematic viscosity are used for high-speed operation, in which thermal expansion has a large impact, and in low temperatures.

Lubrication with high base oil kinematic viscosity is used for oscillating operations, operations in low speeds and in high temperatures.

The following are lubrication methods by grease and by oil.

(1) Grease Lubrication

Grease lubrication is widely used because it does not require a special oil supply system or piping. Grease lubrication accessories available from NSK are:

- Various types of grease in bellows tube which can be instantly attached to the hand grease pump;
- NSK Grease Unit that consists of a hand grease pump and various nozzles. These are compact and easy to use.

1) NSK grease lubricants

Table 6.2 shows the marketed general grease widely used for linear guides. In addition to these grease, NSK provides special grease for specific conditions and purposes.

Table 6.2 Grease lubricant for linear guides

Type	Thickener	Base oil	Base oil kinematic viscosity mm ² /s (40°C)	Range of use temperature (°C)	Purpose
AS2*1	Lithium type	Mineral oil	130	-10 – 110	For general use at high load
PS2*2	Lithium type	Synthetic oil + synthetic hydrocarbon oil	15.9	-50 – 110	For low temperature and high frequency operation
LG2	Lithium type	Mineral oil + synthetic hydrocarbon oil	32	-20 – 70	For clean environment
LGU	Diurea	Synthetic hydrocarbon oil	95.8	-30 – 120	For clean environment
NF2	Urea composite type	Synthetic hydrocarbon oil	26	-40 – 100	For fretting resistant

*1) Standard grease of NH, VH, NS, LW, LH, RA, LA, HA, and HS Series.

*2) Standard grease of PU, LU, PE, and LE Series.

[1] NSK Grease AS2**● Features**

It is environmentally friendly and widely used grease for high-load applications. It is mineral oil based grease containing lithium thickener and several additives. It is superb in load resistance as well as stability in oxidization. It not only maintains good lubrication over a long period of time, but also demonstrates superb capability in retaining water. Even containing a large amount of water, it does not lose grease when it is softened.

● Application

It is standard grease for general NSK linear guides. It is prevalently used in many applications because of its high base oil viscosity, high-load resistance, and stability in oxidization.

● Nature

Thickener	Lithium soap base
Base oil	Mineral oil
Consistency	275
Dropping point	181°C
Volume of evaporation	0.24% (99°C, 22 hr)
Copper corrosion test	Satisfactory (Method B, 100°C, 24 hr)
Oil separation	2.8% (100°C, 24 hr)
Base oil kinematic viscosity	130 mm ² /s (40°C)

[2] NSK Grease PS2**● Features**

The major base oil component is synthetic oil with mineral oil. It is an excellent lubrication especially for low-temperature operation. It is for a high-speed and light-load application.

● Application

It is standard grease for NSK miniature linear guides. It is especially superb for low-temperature operation, but also functions well in normal temperatures, making it ideal for small equipment with light load.

● Nature

Thickener	Lithium soap base
Base oil	Synthetic oil + Synthetic hydrocarbon oil
Consistency	275
Dropping point	190°C
Volume of evaporation	0.60% (99°C, 22 hr)
Copper corrosion test	Satisfactory (Method B, 100°C, 24 hr)
Oil separation	3.6% (100°C, 24 hr)
Base oil kinematic viscosity	15.9 mm ² /s (40°C)

[3] NSK Grease LG2**● Features**

This grease was developed by NSK to be exclusively used for linear guides in clean room. Compared to the fluorine grease which is commonly used in clean room, LG2 has several advantages such as:

- Higher in lubrication function
- Longer lubrication life
- More stable torque (resistant to wear)
- Higher rust prevention.

In dust generation, LG2 is more than equal to the fluorine grease in keeping dust volume low. Since the base oil is not special oil but mineral oil, LG2 can be handled in the same manner as general grease.

● Application

LG2 is the lubrication grease for linear guides for semiconductor and liquid crystal display (LCD) processing equipment which require a highly clean environment. Because LG2 is exclusively for a clean environment at normal temperatures, however, it cannot be used in a vacuum environment.

Refer to "Special environment" in page A60 for the detailed data on superb characteristics of NSK Grease LG2.

● Nature

Thickener	Lithium soap base
Base oil	Mineral oil + Synthetic hydrocarbon oil
Consistency	199
Dropping point	201°C
Volume of evaporation	1.40% (99°C, 22 hr)
Copper corrosion test	Satisfactory (Method B, 100°C, 24 hr)
Oil separation	0.8% (100°C, 24 hr)
Base oil kinematic viscosity	32 mm ² /s (40°C)

[4] NSK Grease LGU**● Features**

This is a proprietary urea base grease of NSK featuring low dust emission exclusively for linear guides which are used in clean room.

In comparison with the fluorine base grease, which has been used commonly in clean room, LGU has better lubricating property, longer duration of lubricant, better torque variation, much better anti-rust property, and equivalent or better dust generation. In addition, this grease can be handled in the same way as the other common grease because high-grade synthetic oil is used as the base oil.

LGU grease contains much less metallic elements compared to LG2 grease. It can be used in high temperature environment.

● Application

This is exclusive lubrication grease for linear guides that are installed in equipment that requires cleanliness, as same as LG2 grease, and it can be used in high temperature range of -30°C to 180°C.

This grease cannot be used in vacuum.

● Nature

Thickener	Diurea
Base oil	Synthetic hydrocarbon oil
Consistency	201
Dropping point	260°C
Volume of evaporation	0.09% (99°C, 22 hr)
Copper corrosion test	Satisfactory (Method B, 100°C, 24 hr)
Oil separation	0.6% (100°C, 24 hr)
Base oil kinematic viscosity	95.8 mm ² /s (40°C)

[5] NSK Grease NF2**● Features**

It uses high-grade synthetic oil as the base oil and urea base organic compound as the thickener. It has remarkable anti-fretting corrosion property. It can be used in wide temperature range, from low to high, and has superior lubrication life.

● Application

This grease suits for linear guides whose application includes oscillating operations. Allowable temperature range is -40°C to 100°C.

● Nature

Thickener	Diurea
Base oil	Synthetic hydrocarbon oil
Consistency	288
Dropping point	260°C
Volume of evaporation	0.22% (99°C, 22 hr)
Copper corrosion test	Satisfactory (Method B, 100°C, 24 hr)
Oil separation	0.5% (100°C, 24 hr)
Base oil kinematic viscosity	26 mm ² /s (40°C)

● Precautions for handling

- Wash the linear guides to remove oil prior to applying Clean Grease LG2 or LGU, so the grease functions are fully utilized.
- The clean grease is exclusively used for clean environments at normal pressure.

2) How to replenish grease

Use the grease fitting of a slide if an exclusive grease supply system is not used. Supply the required amount of grease by a grease pump.

Wipe off old grease and accumulated dust before supplying new grease. If the grease fitting is not used due to the size limitation, apply grease directly to the rail. Remove the seal if possible, and move the slide few strokes so the grease permeates it. A hand grease pump, an exclusive and easy lubricating device for linear guides, is available at NSK.

3) Volume of grease to be replenished

Once grease is replenished, another supply is not required for a long time. But under some operational conditions, it is necessary to periodically replenish grease. The following are replenishing methods.

- When there is an exclusive grease supply system and the volume from the spout can be controlled, the criterion is:

All at once, replenish the amount that fills about 50% of the internal space of the slide. This method eliminates waste of grease, and is efficient.

Page A46 shows the internal spaces of slide of each series for your reference.

- When replenishing grease using a grease pump: Use a grease pump and fill the inside of slide with grease. Supply grease until it comes out from the slide area. Move the slide by hand while filling them with grease, so the grease permeates all areas. Do not operate the machine immediately after replenishing. Always try to run-in the system a few times to spread the grease throughout the system and to remove excess grease from inside. Running-in operation is necessary because the sliding force of the linear guide greatly increases immediately after the replenishment (full-pack state) and may cause problems. Grease's stirring resistance is accountable for this phenomenon. Wipe off excess grease that accumulates at the end of the rail after trial runs, so the grease does not scatter to other areas.

4) Intervals of checks and replenishments

Although the grease is of high quality, it gradually deteriorates and its lubrication function diminishes. Also, the grease in the slide is gradually removed by stroke movement. In some environments, the grease becomes dirty, and foreign objects may enter a slide. New grease should be replenished depending on the frequency of use. The following is a guide of intervals of grease replenishments to linear guides.

Table 6.3 Intervals of checks and replenishments for grease lubrication

Intervals of checks	Items to be checked	Intervals of replenishments
3-6 months	Dirt, foreign matters such as cutting chip	Usually once per year is sufficient. Every 3 000 km for a system such as material handling equipment that travels more than 3 000 km per year. Replenish if checking results warrant it necessary.

Notes: 1) As a general rule, do not mix greases of different brands. Grease structure may be destroyed if greases of different thickeners are mixed. Even when greases have the same thickener, different additives in them may have an adverse effect on each other.

2) Grease viscosity varies by temperature. Viscosity is particular high in winter due to low temperature. Pay attention to increase in linear guide's sliding resistance in such occasion.

Table 6.4 Inside space of the slide

NH Series

Unit: cm³

Model No.	NH	
	High-load type	Ultra-high-load type
15	3	4
20	6	8
25	9	13
30	13	20
35	22	30
45	47	59
55	80	100
65	139	186

VH Series

Unit: cm³

Model No.	VH	
	High-load type	Ultra-high-load type
15	3	4
20	6	8
25	9	13
30	13	20
35	22	30
45	47	59
55	80	100

NS Series

Unit: cm³

Model No.	NS	
	Medium-load type	High-load type
15	2	3
20	3	4
25	5	8
30	8	12
35	12	19

LW Series

Unit: cm³

Model No.	LW
	17
21	3
27	7
35	24
50	52

RA Series

Unit: cm³

Model No.	RA	
	High-load type	Ultra-high-load type
15	1	1.5
20	2	2.5
25	3	3.5
30	5	6
35	6	8
45	10	13
55	15	20
65	33	42

PU, LU Series

Unit: cm³

Model No.	PU		LU	
	Standard type	High-load type	Standard type	High-load type
05	0.1	—	0.1	—
07	0.1	—	0.1	—
09	0.2	0.3	0.2	0.3
12	0.3	0.4	0.3	0.4
15	0.8	1.1	0.8	1.1

PE, LE Series

Unit: cm³

Model No.	PE		LE		
	Standard type	High-load type	Medium-load type	Standard type	High-load type
05	0.1	—	0.1	0.1	—
07	0.2	—	0.1	0.2	0.3
09	0.4	0.5	0.2	0.4	0.5
12	0.5	0.7	0.3	0.5	0.7
15	1.2	1.6	0.8	1.2	1.6

Miniature LH Series

Unit: cm³

Model No.	LH
	08
10	0.4
12	1.2

LA Series

Unit: cm³

Model No.	LA	
	High-load type	Ultra-high-load type
25	8	12
30	14	18
35	21	29
45	38	48
55	68	86
65	130	177

HA, HS Series

Unit: cm³

Model No.	HA	HS
	15	—
20	—	9
25	16	16
30	27	25
35	42	40
45	67	—
55	122	—

5) NSK grease unit

A hand grease pump and lubrication grease contained in a bellows tube (80 g of grease) which can be loaded to the grease pump.



Grease in a bellows tube



[1] Composition of NSK grease unit

Components and grease types are shown below.

NSK Grease Unit				
	Name	(Tube color)	Reference number	
NSK Grease (80 g in a bellows tube)	NSK Grease AS2	(Ocher)	NSK GRS AS2	
	NSK Grease PS2	(Orange)	NSK GRS PS2	
	NSK Grease LG2	(Blue)	NSK GRS LG2	
	NSK Grease LGU	(Yellow)	NSK GRS LGU	
	NSK Grease NF2	(Gray)	NSK GRS NF2	
NSK Hand Grease Pump Unit	NSK Hand Grease Pump (Straight nozzle NSK HGP NZ1 -- One nozzle is provided with a hand grease pump.)		NSK HGP	
	Grease nozzle (used with a hand grease pump)	NSK straight nozzle		NSK HGP NZ1
		NSK chuck nozzle		NSK HGP NZ2
		NSK drive-in fitting nozzle		NSK HGP NZ3
		NSK point nozzle		NSK HGP NZ4
		NSK flexible nozzle		NSK HGP NZ5
		NSK flexible extension pipe		NSK HGP NZ6
		NSK straight extension pipe		NSK HGP NZ7

[2] NSK greases (80 g in a bellows tube)

Refer to pages A43 and D14 for their natures and details.



Fig. 6.6 Bellows tube

[3] NSK hand grease pump unit

a) NSK Hand Grease Pump
(Reference number: NSK HGP)

● Features

- Light-weight Can be operated by one hand, yet there is no worry to make a mistake.
- Inserting by high pressure... Insert at 15 Mpa.
- No leaking Does not leak when held upside down.
- Easy to change grease... Simply attach grease in bellows tube.
- Remaining grease Can be confirmed through slit on tube.
- Several nozzles Five types of nozzles to choose from.

● Specifications

- Discharge rate..... 15 MPa
- Spout volume 0.35 cc/shot
- Mass of main body..... Without nozzle 240 g
Provided nozzle 90 g
- Outer diameter of bellows grease tube..... φ 38.1
- Accessories..... Several nozzles for a unique application can be attached

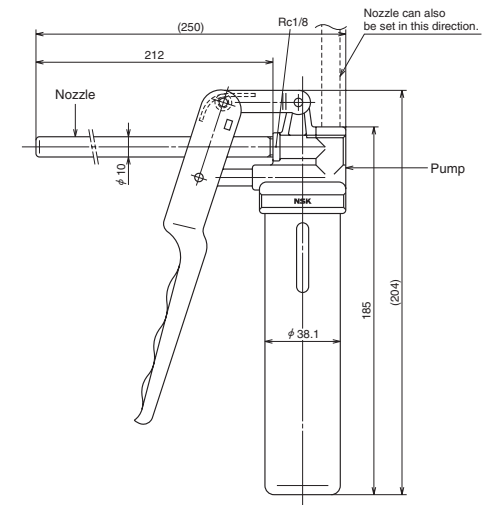

Fig. 6.7 NSK Hand Grease Pump with NSK straight nozzle

*Air is contained in the unopened bellows tube. Try the system tens of times when to use the hand grease pump. The tube will be use after deflated from the tube.

b) Nozzles

Table 6.5 Nozzles that can be attached to NSK Hand Grease Pump

Name	Designation code	Use	Dimensions
NSK straight nozzle	NSK HGP NZ1	Can be used with grease fitting A, B, and C under JIS B1575 standard.	
NSK chuck nozzle	NSK HGP NZ2	Same as above. However, there is no need to press the hand pump because the grease fitting and the nozzle come into contact due to the chucking mechanism at the tip.	
NSK drive-in fitting nozzle	NSK HGP NZ3	Dedicated for the -φ3 drive-in grease fitting.	
NSK point nozzle	NSK HGP NZ4	Used for linear guides that do not have grease fitting. Supplies grease directly to the ball grooves, or through the opening of slide or slide to inside.	
NSK flexible nozzle	NSK HGP NZ5	The tip of the flexible nozzle is a chuck nozzle. The straight nozzle is not available for use.	
NSK flexible extension pipe	NSK HGP NZ6	Flexible extension pipe connects the grease pump and the nozzle	
NSK straight extension pipe	NSK HGP NZ7	Straight extension pipe connects the grease pump and the nozzle.	

Table 6.6 Grease fittings used for NSK linear guide

Series	Model No.	Tap hole for grease fitting	Standard grease fitting	Straight nozzle NZ1	Chuck nozzle NZ2	Drive-in fitting nozzle NZ3	Point nozzle NZ4	Flexible nozzle NZ5
NH Series	NH15	φ 3	Drive-in type			○		
	NH20, 25, 30, 35*	M6×0.75	B type	○	○			○
	NH45, 55, 65	Rc1/8	B type	○	○			○
VH Series	VH15	φ 3	Drive-in type			○		
	VH20, 25, 30, 35*	M6×0.75	B type	○	○			○
	VH45, 55	Rc1/8	B type	○	○			○
NS Series	NS15	φ 3	Drive-in type			○		
	NS20, 25, 30, 35*	M6×0.75	B type	○	○			○
	LW17	φ 3	Drive-in type			○		
LW Series	LW21, 27, 35*	M6×0.75	B type	○	○			○
	LW50	Rc1/8	B type	○	○			○
PU Series	PU05, 07, 09, 12	-	-				○	
	PU15	φ 3	Drive-in type			○		
LU Series	LU05, 07, 09, 12, 15	-	-				○	
PE Series	PE05, 07, 09, 12	-	-				○	
	PE15	φ 3	Drive-in type			○		
LE Series	LE05, 07, 09, 12, 15	-	-				○	
Miniature LH Series	LH08, LH10	-	-				○	
	LH12	φ 3	Drive-in type			○		
RA Series	RA15, 20	φ 3	Drive-in type			○		
	RA25, 30, 35*	M6×0.75	B type	○	○			○
	RA45, 55, 65	Rc1/8	B type	○	○			○
LA Series	LA25, 30, 35*	M6×0.75	B type	○	○			○
	LA45, 55, 65	Rc1/8	B type	○	○			○
HA Series	HA25, 30, 35*	M6×0.75	B type	○	○			○
	HA45, 55	Rc1/8	B type	○	○			○
HS Series	HS15	φ 3	Drive-in type			○		
	HS20, 25, 30, 35*	M6×0.75	B type	○	○			○

Note: PU, LU, PE, and LE Series; Apply grease directly to ball groove, etc. using a point nozzle.

*) When using a chuck nozzle, make sure that it does not interfere with the table on linear guides.

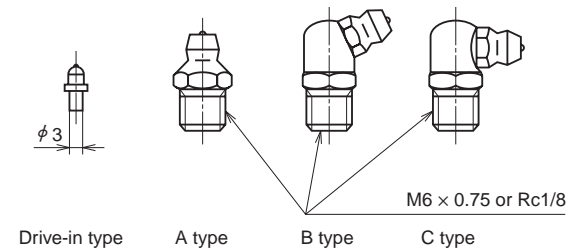

Fig. 6.8 Grease fittings

A long threaded grease fitting is required because of dust-proof parts. Please refer to the sections pertaining to the lubrication and dust-proof parts of each series.

(2) Oil lubrication

Required amount of new oil is regularly supplied by:

- Manual or automatic intermittent supply system;
- Oil mist lubricating system via piping.

Equipment for oil lubrication is more costly than one for grease lubrication. However, oil mist lubricating system supplies air as well as oil, thus raising the inner pressure of the slide. This prevents foreign matters from entering, and the air cools the system. Use an oil of high atomizing rate such as ISO VG 32-68 for the oil mist lubrication system.

ISO VG 68-220 are recommended for common intermittent replenishment system. Approximate volume of oil Q for a slide of linear guide per hour can be obtained by the following formula.

In case of all ball type linear guides except LA series

$$Q \geq n/150 \text{ (cm}^3\text{/hr)}$$

In case of LA and RA series

$$Q \geq n/100 \text{ (cm}^3\text{/hr)}$$

n : Linear guide size code

e.g. When NH45 is used,

$$n = 45,$$

Therefore,

$$Q = 45/150 = 0.3 \text{ cm}^3\text{/hr}$$

For the oil lubrication by gravity drip, the oil supply position and installation position of the slide are crucial. In case of linear guide, unless it is installed to a horizontal position, the oil flows only on the down side, and does not spread to all raceway surface. This may cause insufficient lubrication. Please consult NSK to correct such situations prior to use. NSK has the internal design which allows oil lubricant to flow throughout the system.

Table 6.7 shows the criterion of intervals of oil checks and replenishments.

Table 6.7 Intervals of checks and replenishments

Method	Intervals of checks	Items to check	Replenishment or intervals of changes
Automatic intermittent supply	Weekly	Volume of oil, dirt, etc.	Replenish at each check. Suitable volume for tank capacity.
Oil bath	Daily before operation	Oil surface	Make a suitable criterion based on consumption

Notes: 1) As with grease lubrication, do not mix oil lubricant with different types.

2) Some components of the linear guide are made of plastic. Avoid using an oil that adversely affects synthetic resin.

3) When using oil mist lubricating system, please confirm an oil supply amount at the each outlet port.

A-3-7 Dust Proof

1. Standard specification parts

- To keep foreign matters from entering inside the slide, NSK linear guides have end seals on both ends, bottom seals at the bottom surfaces, and an inner seal in the inside of slide.
- The seals for standard specification for each series are shown in **Table 7.1**.
- Seal friction per a standard slide is shown in the technical description of the dust-proof parts of each series.

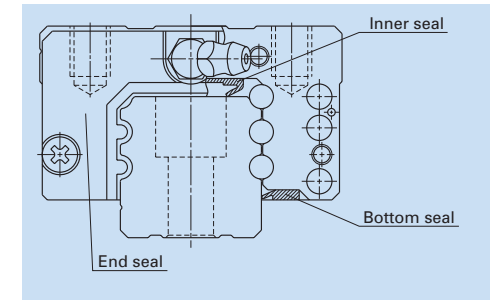

Fig. 7.1

Table 7.1 Standard seals

		End seal	Bottom seal	Inner seal
NH Series	NH15	○	○	-
	NH20, NH25, NH30, NH35, NH45, NH55, NH65	○	○	△
VH Series	VH15	○	○	-
	VH20, VH25, VH30, VH35, VH45, VH55	○	○	△
NS Series	NS15	○	○	-
	NS20, NS25, NS30, NS35	○	○	△
LW Series	LW17, LW21, LW27, LW35, LW50	○	○	-
PU Series	PU05, PU07, PU09, PU12, PU15	○	-	-
LU Series	LU05, LU07, LU09	△	-	-
	LU12, LU15	○	-	-
PE Series	PE05, PE07, PE09, PE12, PE15	○	-	-
LE Series	LE05, LE07, LE09, LE12, LE15	○	-	-
Miniature LH Series	LH08, LH10	○	-	-
	LH12	○	○	-
RA Series	RA15, RA20	○	○	△
	RA25, RA30, RA35, RA45, RA55, RA65	○	○	○
LA Series	LA25, LA30, LA35, LA45, LA55, LA65	○	○	△
HA Series	HA25, HA30, HA35, HA45, HA55	○	○	○
HS Series	HS15, HS20, HS25, HS30, HS35	○	△	-

○ : Equipped as a standard feature

△ : Available upon request

2. Dust-proof parts

- NSK has the following items for the dust-proof parts. Select a suitable type for the operating environment.

Table 7.2 Optional dust-proof parts

Name	Purpose	Reference page
NSK K1 lubrication unit	Made of oil impregnated resin. Enhances lubricating functions.	A38 – A41
Double seal	It combines two end seals for enhancing sealing function.	A53
Protector	Protect the end seal from hot and hard contaminants.	A54
Rail cap	Prevents foreign matters, such as swarf generated in cutting operation from clogging the rail-mounting holes.	A54
Inner seal	Installed inside a slide, and prevents foreign matters from entering the rolling contact surface.	A55
Bellows	Covers the linear guide.	A55
Rail cover *	Covers the rail top surface, and prevents foreign matters, such as cutting dust, from collecting in the rail mounting holes.	A256

*) The rail cover is available only for RA25 to RA65 of RA series.

(1) Double seal

- It is a combination of two end seals to enhance seal function.
- When the double seal is installed, the end seal section becomes thicker than the standard item. Please pay attention to the increase in a slide length when designing the mounting dimension of slide and the table stroke. Please refer to the section of dust-proof components for the dimensional increase in the length direction of each series due to fitting of double seal.
- Double-seal set: Can be installed to a completed standard ball slide assembly later upon request. It comprises two end seals, two collars, and two machine screws for installation (**Fig. 7.2**). The product reference numbers of each series are described on the section of dust-proof parts.
- When attaching a grease fitting to the end cap after the double seal is equipped, you require a connector shown in **Fig. 7.2**. Please specify the connector set when ordering the linear guides.
- For VH, RA, LA, HA, and HS Series, the double-seal set can be only installed before shipping from the factory.

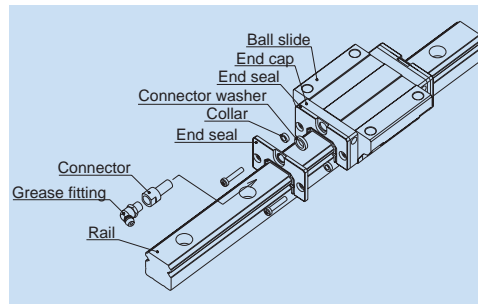

Fig. 7.2 Double seal

(2) Protector

- A protector is usually installed outside the end seal to prevent high-temperature fine particles such as welding spatter and other hard foreign matters from entering the slide.
- Same as the case with the double seal, when the protector is installed, the slide becomes longer. Take this thickness of slide into consideration for determining the relevant dimensions such as the system stroke and the ball slide installation envelope. An increase in the length of the ball slide due to the installation of protector is shown in the technical description of the dust-proof parts of each series.
- The protectors are available from the stock and we can install them to a completed standard slide assembly upon request. The model numbers of the protectors for ordering are shown in the technical explanation of the dust-proof parts of each series.
- When attaching a grease fitting to the end cap after the protector is equipped, you require the connector shown in **Fig. 7.3**. Please specify the connector set when ordering the linear guides.
- For VH, RA, LA, HA, and HS Series, the protector can only be installed only before shipping from the factory.

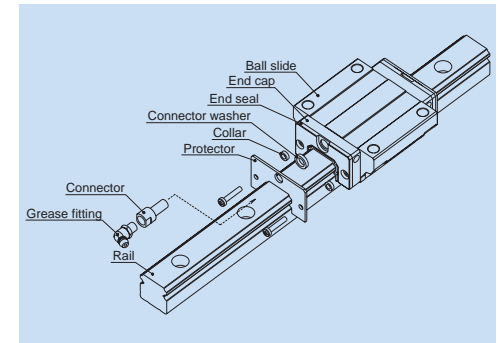

Fig. 7.3 Protector

(3) Bolt-hole cap to plug the bolt holes for rail mounting

- After the rail is mounted to the machine base, a bolt-hole cap is used to plug the bolt hole to prevent foreign matters from clogging up the hole and from entering into the slide (**Fig. 7.4**).
- The bolt-hole cap is made of synthetic resin which has superb in its resistance to oil and abrasion.
- Sizes of the bolt for the each linear guide model as well as the reference number of the bolt-hole cap are shown in the technical description of the dust-proof parts of each series.
- To insert the cap into the rail bolt hole, use a flat dolly block (**Fig. 7.5**). Pound the cap gradually until its height becomes flush with the rail top surface.
- You can reorder extra bolt hole caps. Sizes of the bolts and each model number of bolt-hole caps are shown in the technical description of the dust-proof parts of each series.
- Caps which are made of metal is also available upon request.

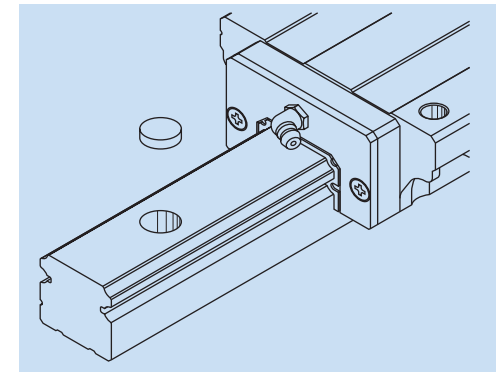

Fig. 7.4

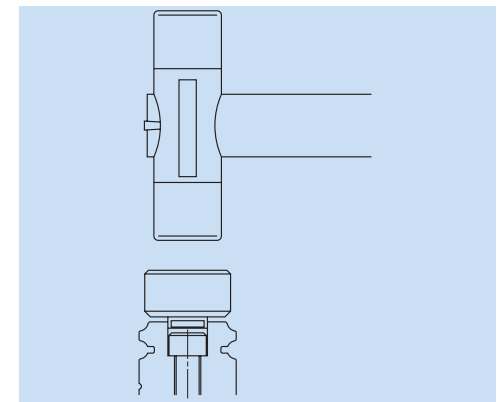

Fig. 7.5

(4) Inner seal

- The end seal installed on both ends of a slide cannot arrest entire contaminant, though the missed amount is negligible. An inner seal protects the rolling contact surface from such contaminant which entered inside the slide (**Fig. 7.6**).
- The inner seal is installed inside the slide. Therefore, the appearance in size and the shape are the same as the standard slide. (The inner seal is already installed before shipping.)
- It is strongly recommended to use the bellows and the double seal along with the inner seal to maintain the precision of the linear guide.
- Refer to **Table 7.1** for availability of inner seal.

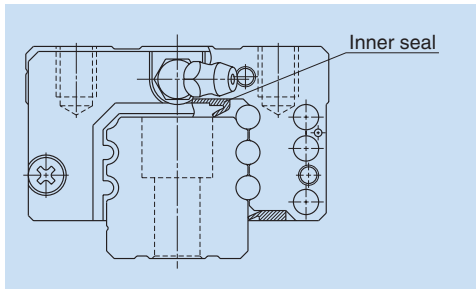

Fig. 7.6 Inner seal when installed

[1] Installation of bellows NH and NS Series

* Fixing to the ball slide (Fig. 7.7)

- Remove two machine screws (M_2) which secure the end seals to the end of the slide (**Fig. 7.7**). For NS15, hold the end cap by hand. Otherwise, the end cap is detached from the ball slide, and the balls inside may spill out.
- Then insert a spacer to the hole for securing the end seal. Fasten the mounting plate at the end of the bellows to the slide with a slightly longer machine screw (provided with the bellows).

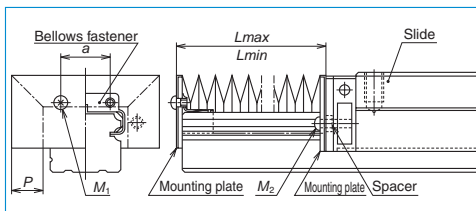

Fig. 7.7

(5) Bellows

- A bellows covers entire linear guide. It has been used widely as a way of protection in an environment where foreign matters are prevalent.
- NSK has bellows exclusively for NH, NS, LW, RA and LA Series. They have a middle bellows and a bellows at both ends. For NH Series, there are low and high type bellows which are in compliance with their slide types.
- The high type is used for AN and BN types. The low type is used for EM, GM, AL and BL types. The top of the high type bellows is slightly lower than the top surface of the slide.
- When a high type bellows is installed to the slide with the height code L (such as AL), the top of the bellows becomes higher than the slide. However, it is advantageous for stroke because the pitch of the bellows becomes larger than the low type.
- Special bellows are required when installing the linear guide vertically, or hanging it from a ceiling. Please consult NSK in such a case.
- When a bellows is used, please be advised that we cannot put a grease fitting on the end of slide to which the bellows is attached. If you require the grease fitting, it shall be put on the side of end cap or slide body. Consult NSK for details.
- For the dimension of bellows, please refer to the section of dust proof parts of each series.

* Fixing to the rail

- To install bellows for NH and NS Series, lightly knock a fastener exclusively for bellows to the end of the rail (**Fig. 7.7**). Then secure the mounting plate to the end of the bellows through the tap hole of the fastener.
- As described above, a bellows can be easily fixed to the end of the rail without adding a tap hole on the end of the rail.
- Bellows fastener is available only for the horizontal mounting positions. For other mounting positions, sliding plate is required (see **Fig. 7.10** on page A56.)

For fixing to the rail, make tap holes to the rail end surface. Fix the bellows mounting plate to the rail end surface through these tap holes by using a machine screw. NSK processes a tap hole to the rail end face when ordered with a linear guide.

[2] LW and LA Series

* Fixing to the ball slide (Fig. 7.8 and Fig. 7.9)

- Remove two machine screws which secure the end seal. (For LW17 and LW21, hold the end cap by hand while removing the machine screw. Otherwise, the end cap is detached from the slide, and the balls inside may spill over and fall.)
- Insert a spacer to the securing hole of the end

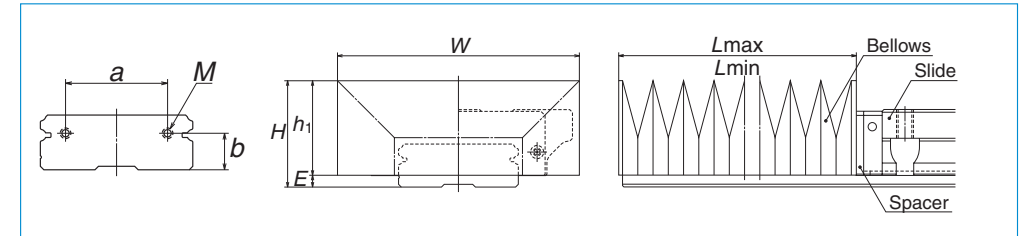

Fig. 7.8

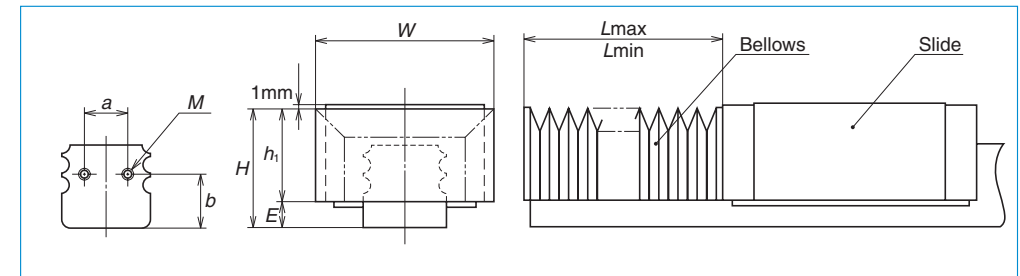

Fig. 7.9

[3] RA Series

- Please refer to page A260.

Calculating length of bellows

- The formula is as follows excluding RA series.
- A bellows forms one block (BL) with six folds as shown in **Fig. 7.10**. The stroke is determined by multiplying by an integer of this BL.
- Length when stretched to the maximum length :
 $L_{max} = 7 \times P \times \text{Number of BL}$

- Length when contracted to the minimum length :
 $L_{min} = 17 \times \text{Number of BL}$
- Stroke :
 $St = L_{max} - L_{min}$
- The dimension of P and the number of BL are shown in the bellows dimension table of each series.
- In case of RA series, refer to page A260.

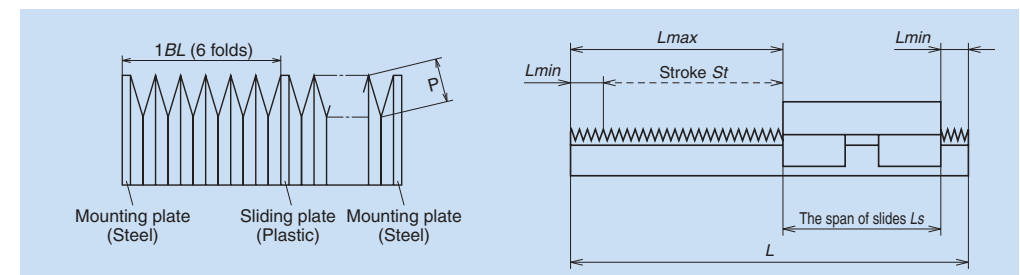

Fig. 7.10

A-3-8 Rust Prevention (Stainless Steel and Surface Treatment)

1. Stainless steel

NSK linear guide is available in stainless steel.

○Stainless steel standard series

PU Series PE Series
LE Series Miniature LH Series LL Series

○Available in stainless steel

NH Series
NS Series
LU Series

Select from the above when using in the environments which invite rust.

2. Surface treatment

(1) Recommended surface treatment

We recommend "low temperature chrome plating" and "fluoride low temperature chrome plating" for rust prevention because of the result of the humidity chamber test for antirust characteristics and their cost-effectiveness.

However, never apply any organic solvent to those treatments for degreasing because it has adverse effect on antirust characteristics.

Refer to the next page for the results of humidity chamber test.

Please consult NSK for other surface treatment.

○**Low temperature chrome plating (Electrolytic rust prevention black treatment)**

- Used to prevent corrosion, light reflection, and for cosmetic purpose.

○**Fluoride low temperature chrome plating**

- Fluoroplastic coating is provided following the low temperature chrome plating.
- Resistance to corrosion is higher than electrolytic rust prevention film treatment.

(2) Rust prevention of fluoride low temperature chrome plating

The use environment of NSK linear guides is expanding from general industrial machines, semiconductor and liquid crystal manufacturing systems to aerospace equipment.

Among all measures to cope with environment, rust prevention is the most challenging. Such environment includes:

- Moisture for washing machines and other equipment
- Chemicals used in the wet processing of semiconductor and liquid crystal display manufacturing equipment

NSK has developed electrolytic rust prevention black film treatment (black chrome plating) which is added by fluororesin impregnating treatment. (Hereinafter referred as "Fluoride low temperature chrome plating") This surface treatment methods has proved its superiority as the rust prevention of linear guides which are used in the above equipment.

● What is "Fluoride low temperature chrome plating?"











This is a type of black chrome plating which forms a black film (1 to 2 μm in thickness) on the metal surface. Fluoroplastic coating is added to the film to increase corrosion resistance.

- Accuracy control is easily manageable due to low temperature treatment and to the absence of hydrogen embrittlement.
- Product accuracy is less affected due to the thin film which has high-corrosion resistance.
- This method is superior to other surface treatments in durability on the rolling surface.
- Inexpensive compared with products with other surface treatment and stainless steel products.

However, do not use organic solvent because it adversely affects antirust property of the plating.

● Humidity chamber test

Table 8.1 Results of the humidity test

Characteristic		Test sample				
		Fluoride low temperature chrome plating (Recommended)	Hard chrome plating (Reference)	Electroless nickel plating (Reference)	Equivalent to SUS440C material	Standard steel
Rusting	Top	(Ground) B	(Ground) B	(Ground) A	(Ground) C	(Ground) D
	Side	(Ground) A	(Ground) A	(Ground) A	(Ground) C	(Ground) E
	Bottom	(Ground) A	(Ground) A	(Ground) A	(Ground) C	(Ground) E
	End	(Machined) A	(Machined) C	(Machined) A	(Machined) C	(Machined) E
	Chamfer/grinding recess	(Drawn) A	(Drawn) D	(Drawn) A	(Drawn) C	(Drawn) E
Corrosion-resistant property	<Test conditions> ● Testing chamber: High temperature, highly moist chamber (made by DABAI ESPEC) ● Temperature: 70°C ● Relative humidity: 95% ● Testing time: 96 h Time to "ramp-up" and "ramp-down" conditions of the temperature and the humidity Ramp-up: 5 h Ramp-down: 2 h					
						
Film thickness		5 μm	0.5 – 7 μm	10 μm	—	—
		Rusting	A: No rust C: Spotty rust	B: Not rusted, but slightly discolored D: Slightly rusted	E: Completely rusted	

● Chemical corrosion resistance test

Table 8.2 Results of the corrosion resistance test

Test conditions Rail base material : Equivalent to SUS440C
Chemical density : 1 mol/l

Fluoride low temperature chrome plating		Hard chrome plating (reference)	None surface treatment
	Immersed in solution for 24 hrs Nitric acid		
	Immersed in solution for 24 hrs Fluoride		
	Immersed in solution for 72 hrs Hydrochloric acid type washing solution HCl : H ₂ O ₂ : H ₂ O = 1 : 1 : 8		
○	Hydrochloric acid (immersed)	○	▲
○	Sulfuric acid (immersed)	○	×
○	Ammonia or sodium hydroxide	○	△

○: Normal △: Partial surface damage ▲: Overall surface damage ×: Corroded

● Surface treatment durability test

Peeling resistance of surface treatment

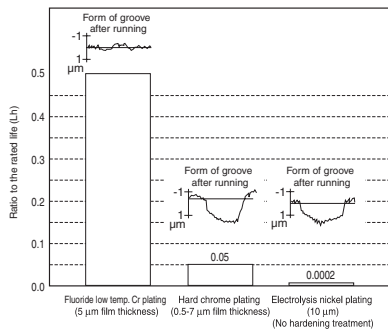

Fig. 8.1 Results of durability test

● Total evaluation

Table 8.3 Evaluation

	Rust prevention ability	Quality stability	Durability	Cost
Fluoride low temperature chrome plating (recommended)	◎	○	◎	◎
Hard chrome plating (reference)	○	×	△	△
Electroless nickel plating (reference)	◎	△	×	△
Material equivalent to SUS440C	○	◎	◎	△

◎: Excellent ○: Suitable in use
△: Not so good for use ×: Problem in use

A-3-9 Special Environment

1. Heat-resistant specifications

- Standard linear guides use plastic for rolling element recirculation component. The maximum temperature in use for standard linear guides is 80°C.
- Use the linear guide with heat-resistant specifications under temperatures that exceed this limit.

Table 9.1 Comparison of materials: Standard and heat-resistant specifications

Component	Standard specification	Heat-resistant specification
Rail	Special high carbon steel (equivalent to SUS440C/JIS)	Special high carbon steel (equivalent to SUS440C/JIS)
Slide	Special high carbon steel (equivalent to SUS440C/JIS)	Special high carbon steel (equivalent to SUS440C/JIS)
Rolling elements	SUJ2, SUS440C	SUJ2, SUS440C
Retainer	Polyacetals	SUS304
Retaining wire	SUS304	SUS304
End cap	Polyacetals	SUS316L
Return guide	Polyacetals	SUS316L
End seal	Acrylonitril-butadiene rubber, SPC/JIS and stainless steel	Fluoro rubber, SPC/JIS and stainless steel
Bottom seal	Acrylonitril-butadiene rubber, SPC/JIS and stainless steel	Fluoro rubber, SPC/JIS and stainless steel

Heat resistant linear guides

- NH Series NS Series
- LW Series LU Series
- LE Series

See page A66 for the availability.

2. Vacuum and clean specifications

- Based on its abundant experience and technology, NSK manufactures linear guides that can be used in a vacuum or in clean environment. Please consult NSK for more details.
- Linear guide specifications vary for environmental conditions. For example, "all stainless steel plus special grease, or solid film lubricant is suitable" for vacuum environment.
- NSK has low-dust generating grease "LG2" and "LGU" which are ideal for clean environment. Refer to page A43 for details.

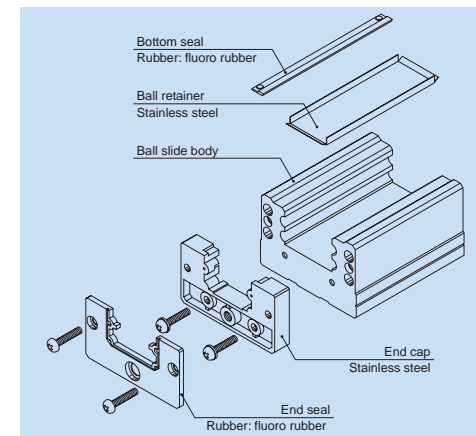
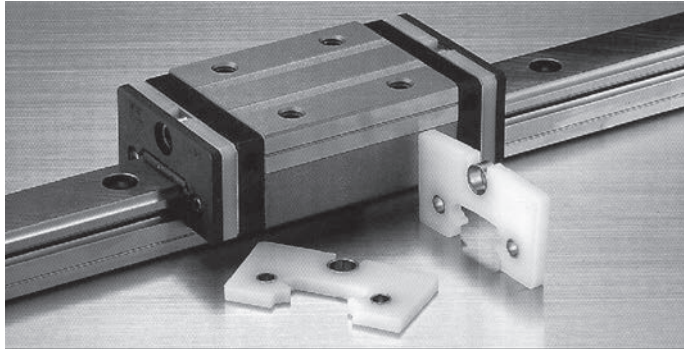

Fig. 9.1

3. "NSK linear guides for food processing equipment and medical devices" for sanitary environment

Used with NSK K1 for food processing equipment and medical devices and grease for food processing equipment.



What is "NSK K1™" for food processing equipment and medical devices?

With an amazing innovation lubrication unit, the NSK K1 for food processing equipment and medical devices utilizing the US Food and Drug Administration (FDA) compliant material, provides reliability when used in food processing equipment and medical devices. The newly developed porous synthetic resin contains abundant lubricant.

With the basic function of highly praised NSK K1 lubrication unit for general industry, more sophisticated materials make it applicable in food and medical equipment.

It also offers easy installation: it is installed inside the standard end seal.

(1) Features

1) The highest grade of category H1 grease of USDA standard is used for NSK K1 lubrication unit.

*category H1: Lubricants permitted for use where there is possibility of incidental food contact

*USDA: USDA (The United States Department of Agriculture)

<Features of grease for food processing machines>

• This grease is approved by USDA H1. (National Science Foundation [NSF] carries out certification for USDA.)

- Superb water resistance and antirust capability
- Superb wear resistance
- Applicable for a centralized oiling system

2) Appropriate volume of grease

A supply of appropriate volume of grease reduces grease draining and scattering, and maintains a clean environment.

(2) Available models

Table 9.2 shows available models.

Table 9.2

NH Series	NH15, NH20, NH25, NH30 and NH35
NS Series	NS15, NS20, NS25, NS30 and NS35
LW Series	LW17, LW21, LW27 and LW35
PU Series	PU09, PU12 and PU15
LU Series	LU09, LU12 and LU15
PE Series	PE09, PE12 and PE15
LE Series	LE09, LE12 and LE15
Miniature LH Series	LH12

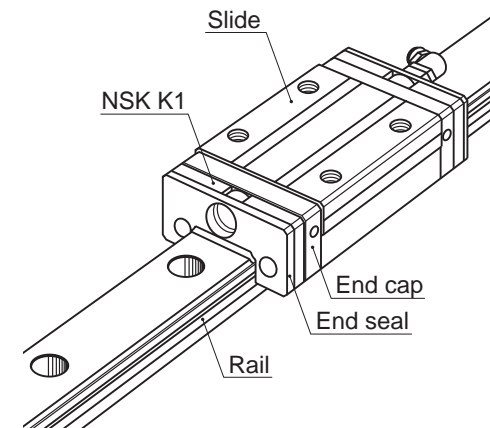

Precautions for use

To maintain optimal performance of NSK K1 lubrication unit over a long time, please follow the instructions below:

1. Temperatures range for use: Maximum temperature in use: 50°C
Momentary maximum temperature in use: 80°C
2. Chemicals that should not come to contact:
Do not leave NSK K1 lubrication unit in organic solvent, white kerosene such as hexane, thinner which removes oil, and rust prevention oil which contains white kerosene.

Note: Water-type cutting oil, oil-type cutting oil and grease such as mineral-type and ester-type do not damage NSK K1 lubrication unit.

4. Specifications for special environments

Table 9.3 Linear guide specifications

Environment	Condition	NSK linear guide specifications				Technical Explanation Page No.
		Rail, slide	Steel balls/rollers	Ball Recirculation component	Lubrication/surface treatment	
Clean	Atmosphere, normal temperature	Standard material	Standard material	Standard material	LG2 Grease, LGU Grease NSK K1 lubrication unit	D8 D10
		Martensitic stainless steel	Martensitic stainless steel	Austenitic stainless steel	LG2 Grease, LGU Grease NSK K1 lubrication unit	D8 D10
	Fluoride low temperature chrome plating				D5	
	Atmosphere-Vacuum, normal temperature				Fluoride grease	
Atmosphere-Vacuum up to 200°C						
Vacuum	Atmosphere-Vacuum, normal temperature	Martensitic stainless steel	Martensitic stainless steel	Austenitic stainless steel	Fluoride grease	
	Atmosphere-Vacuum up to 200°C					
	Atmosphere-Vacuum up to 300°C				Molybdenum disulfide	
	High vacuum up to 500°C				Special silver film	D7
Corrosion resistance	Vapor, steam	Martensitic stainless steel	Martensitic stainless steel	Austenitic stainless steel		
	Acid, alkali	Standard material	Standard material	Standard material	Fluoride low temperature chrome plating	D5 D5
		Acid, alkali, clean	Martensitic stainless steel	Martensitic stainless steel	Austenitic stainless steel	Fluoride low temperature chrome plating
	LG2 Grease, LGU Grease					D8
	Strong acid, strong alkali				Fluoride low temperature chrome plating	D5
	Organic solvent				Fluoride grease	
High temperature	Atmosphere up to 150°C	Standard material	Standard material	Austenitic stainless steel	ET-100K Grease	
	Atmosphere Up to 200°C	Martensitic stainless steel	Martensitic stainless steel		Fluoride grease	
	Atmosphere Up to 200°C, Corrosion resistant				Fluoride grease	
Low temperature	-273°C and higher	Martensitic stainless steel	Martensitic stainless steel	Austenitic stainless steel	Solid lubricant	
Radiation resistance	Atmosphere	Standard material	Standard material	Standard material	Radiation resistant grease	
		Martensitic stainless steel	Martensitic stainless steel	Austenitic stainless steel		
Foreign matters	Fine particles, wooden chips	Standard material	Standard material	Standard material	NSK K1 lubrication unit	D10 D10
			Martensitic stainless steel	Austenitic stainless steel		
	Water, under water	Martensitic stainless steel	Standard material	Standard material		D10
			Martensitic stainless steel	Austenitic stainless steel		D10

5. Lubrication and materials

(1) Lubrication

Grease can be used for high rotation and magnetic field. However, grease evaporates or solidifies in special environment such as vacuum, high temperature, and low temperature. Solid lubricant is used when it is difficult to use grease. Functions of solid lubricant differ greatly by condition where it is used. It is important to select the most suitable solid lubrication for the environment.

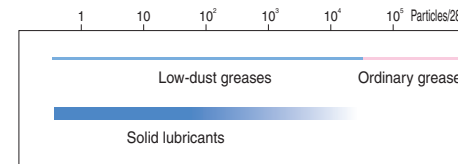

Fig. 9.2 Lubrication in clean environment

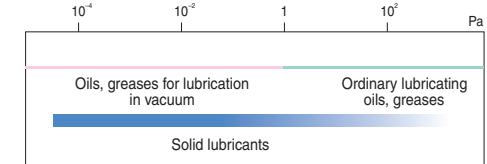

Fig. 9.3 Lubrication in vacuum

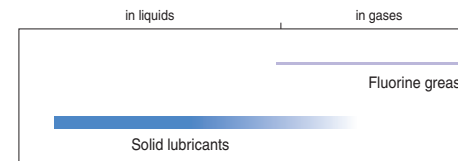

Fig. 9.4 Lubrication in corrosive environment

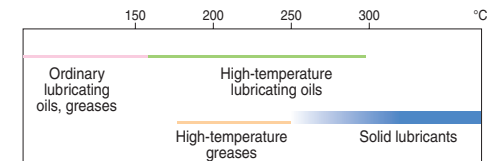

Fig. 9.5 Lubrication in high temperature

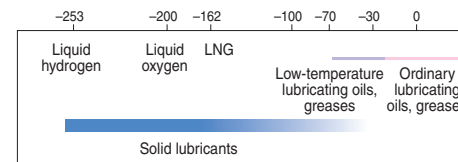

Fig. 9.6 Lubrication in low temperature

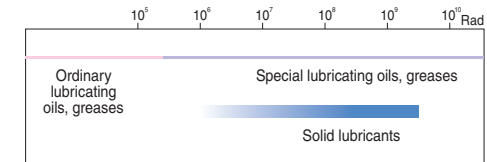

Fig. 9.7 Lubrication in radioactive environment

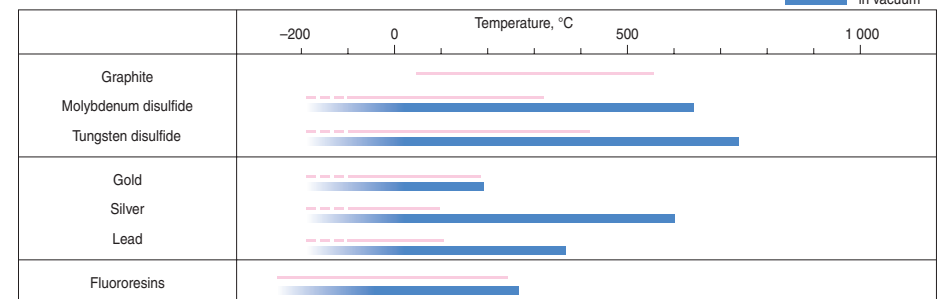

Fig. 9.8 Temperature range for using solid lubricants

(2) Materials

Iron type metals are used in vacuum, high temperature, and high speed environments as the basic material. We generally use nonmagnetic stainless steel for nonmagnetic materials.

Table 9.4 Characteristics of metal materials

Application	Type of steel	Linear expansivity ×10 ⁻⁶ /°C	Young's modulus GPa	Hardness * HB
For clean environment, vacuum environment, corrosion resistance, low temperature, high temperature, radioactive resistance	Martensitic stainless steel SUS440C	10.1	200	580
	Austenitic stainless steel SUS304	16.3	193	150
	Precipitation hardened stainless steel SUS630	10.8	200	277 – 363
Nonmagnetic	Nonmagnetic stainless steel	17.0	195	420

*) Hardness of steel is usually indicated by Rockwell C Scale. For comparison, these figures are expressed by Brinell number.

6. Responsiveness of NSK linear guides for special environments

Series	Model No.	Special environment which linear guide can tolerate						
		Clean	Vacuum	Corrosion	High temp.	Hygienic	High dust proofing	
NH	NH15	○		○		○		
	NH20	○		○		○		
	NH25	○	○	○		○		
	NH30	○	○	○		○		
	NH35	○		○		○		
	NH45	○		○		○		
	NH55	○		○				
	NH65	○		○				
	VH15	○		○			○	
	VH20	○		○			○	
VH	VH25	○		○			○	
	VH30	○		○			○	
	VH35	○		○			○	
	VH45	○		○			○	
	VH55	○		○			○	
NS	NS15	○	○	○	○	○		
	NS20	○	○	○	○	○		
	NS25	○	○	○	○	○		
	NS30	○	○	○	○*	○		
	NS35	○	○	○	○*	○		
LW	LW17	○		○	○*	○		
	LW21	○		○	○*	○		
	LW27	○		○	○	○		
	LW35	○		○	○	○		
PU	LW50	○		○				
	PU05	○		○				
	PU07	○		○				
	PU09	○		○		○		
	PU12	○		○		○		
	PU15	○		○		○		
	LU	LU05	○		○			
		LU07	○		○			
		LU09 L	○	○	○	○	○	
		LU09 R	○		○		○	
LU12 L		○	○	○	○	○		
LU12 R		○		○		○		
LU15		○	○	○	○*	○		

*) Applicable except for the dust-proofing parts.

Series	Model No.	Special environment which linear guide can tolerate						
		Clean	Vacuum	Corrosion	High temp.	Hygienic	High dust proofing	
PE	PE05	○		○				
	PE07	○		○				
	PE09	○		○		○		
	PE12	○		○			○	
	PE15	○		○			○	
	LE	LE05	○		○			
LE07		○	○	○	○*			
LE09 L		○	○	○	○*	○		
LE09 R		○		○		○		
LE12 L		○	○	○	○	○		
LE12 R		○		○		○		
RA	LE15 L	○	○	○	○	○		
	LE15AR	○		○		○		
	MH	LH08	○		○			
		LH10	○		○			
	LA	LH12	○	○	○	○*	○	
		RA15	○		○			
	HA	RA20	○		○			
		RA25	○		○			
		RA30	○		○			
		RA35	○		○			
RA45		○		○				
RA55		○		○				
HS	RA65	○		○				
	LA25	○		○				
	LA30	○		○				
	LA35	○		○				
	LA45	○		○				
	LA55	○		○				
HA	LA65	○		○				
	HA25	○		○				
	HA30	○		○				
	HA35	○		○				
	HA45	○		○				
	HA55	○		○				
HS	HS15	○		○				
	HS20	○		○				
	HS25	○		○				
	HS30	○		○				
HS35	○		○					

7. Precautions for handling

Please observe the following precautions to maintain high functions of NSK linear guide.

- Products are washed to remove oil, and wrapped in a way to protect them from moisture. Use the product as soon as possible after opening the package.
- After opening, store the products in a clean, air-tight container such as desiccator with desiccating agent (e.g. silica gel). Do not apply rust preventive oil or an antirust paper that vaporizes rust preventive agent.
- Wear plastic gloves and handle product in a clean place.

Note: Please refer to the catalog "CAT. No. E1258 SPACEA" for the details of special environmental use.

A-3-10 Arrangement and Mounting of Linear Guide

1. Arrangement

- For NSK linear guides, the datum surfaces of the rail and of the slide are either marked with a "datum surface groove" or with an "arrow."
- In case that two or more linear guides are used together, one linear guide is designated as a reference side guide, and the rest is adjusting side guide(s). The reference side linear guide has its reference number, serial number, and "KL" mark on the opposite side of the datum surface (Fig. 10.1).
- When the datum surfaces of the reference side rail and slides are pressed to their mounting datum surfaces respectively, the variation of distance (mounting width W_2 or W_3) between the datum surfaces of the rails and that of the slides must be a minimum and therefore, it is specified as the standard. (Figs. 10.2 and 10.3)
- The ways to indicate the datum surfaces of each series are shown in Table 10.1.

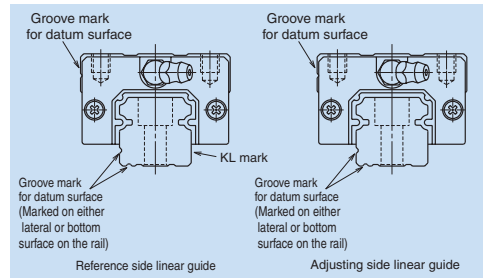

Fig. 10.1 Datum surface

Table 10.1 Marks on the rail datum surfaces in each series

Model No.	Standard	LU05, 07, 09 PU05, 09, 12, 15 LE07, 09, 12	LU12, 15, NH15, NS15	PU07, LE05, 15 LE09, 12 (with a ball retainer) PE series LH08, 10, 12 LW17, 21 RA15
Material				
Special high carbon steel				
Stainless steel				

Example of arrangement

- The arrangement of the linear guides must be determined taking into account the table mounting position (horizontal, vertical, inclined, or upside-down), strokes and the size of the machine base to which the table is mounted. Table 10.2 shows common arrangement examples and their properties (features/precautions).

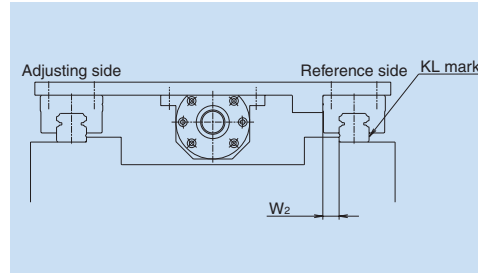

Fig. 10.2 Most common setting of the reference side rail

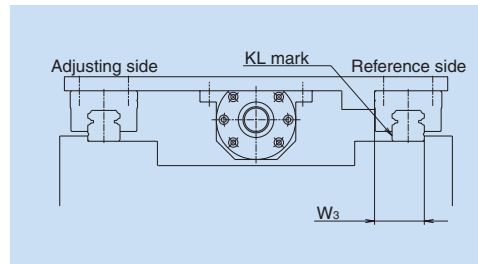

Fig. 10.3 Setting of the reference side rail in certain occasions

Table 10.2 Arrangement example

Arrangement	Features/Precautions
	<ul style="list-style-type: none"> Easy for a highly-accurate installation (recommended arrangement)
	<ul style="list-style-type: none"> Easy in highly-accurate installation The lubricant oil may not be supplied to slides. <u>When oil lubricant is used, special care is required to design the oil supply routing.</u>
	<ul style="list-style-type: none"> Slightly difficult for a highly-accurate installation The life of the linear guides is affected by the mounting accuracy. <u>When oil lubricant is used, special care is required to design the oil supply routing.</u>
	<ul style="list-style-type: none"> Difficult for a highly-accurate installation <u>When oil lubricant is used, special care is required to design the oil supply routing.</u>
	<ul style="list-style-type: none"> Rather easy for a highly-accurate installation <u>When oil lubricant is used, special care is required to design the oil supply routing.</u>
	<ul style="list-style-type: none"> Easy in highly-accurate installation if the linear guides are installed to the machine base first, and then hung them upside down along with the machine base. The slide may detach from the rail and fall down if the linear guide is damaged and rolling elements in the slide fall out. It is necessary to take preventive measures against the falling of the ball slide.

2. Mounting accuracy

(1) Accuracy of the mounting base of machine

- The mounting accuracy of linear guide usually copies the accuracy of the machine base.
- However, when two or more slides are assembled to each rail, the table stroke becomes shorter than the mounting surface. This, along with the fact that the mounting error is evenly spread, contributes to a higher table accuracy than the mounting surface accuracy, reducing the error to about 1/3 in average (Fig. 10.4).

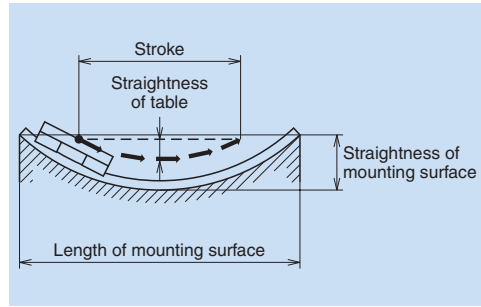

Fig. 10.4

(2) Installation error

- Mounting error affects mainly three factors: life, friction and accuracy (Table 10.3).

Table 10.3 Influence of mounting error

Factor	Influence
Life	<ul style="list-style-type: none"> • Large mounting error generates a force which twists the slide and reduces its life. • It also distorts the contact point of the ball and the groove, and changes contact angle, thus lowering the table rigidity.
Friction	<ul style="list-style-type: none"> • NH and NS Series are affected very little by mounting error thanks to their small friction. (self aligning capability) • However, because of off-set Gothic arch grooves, their friction suddenly soars once the mounting error exceeds a certain level. • The mounting error severely affects friction of LA Series with heavy preload.
Accuracy	<ul style="list-style-type: none"> • When the rigidity of four slides is equal, the theoretical straightness becomes 1/2 of the installation error "e₁". • However, this value becomes slightly larger due to the deformation of the rail and the machine base.

(3) Permissible values of mounting error

- Among the three factors of life, friction, and accuracy, which are affected by the mounting error, NSK focuses on the life factor to determine the permissible mounting accuracy. The specifications are based on the following conditions.

For ball linear guides

- The permissible load per ball slide due to the mounting error is 10% of the basic dynamic load rating C_{50} .
- The rated life is 5 000 km.
- The rigidity of the machine base is infinite.

For roller linear guide

- The permissible load per roller slide due to the mounting error is 10% of the basic dynamic load rating C_{100} .
- The rated life is 10 000 km.
- The rigidity of the machine base is infinite.

C_{50} ; Basic dynamic load rating for 50 km rated fatigue life

C_{100} ; Basic dynamic load rating for 100 km rated fatigue life

- Figs. 10.5 and 10.6 are representing the mounting errors of e_1 and e_2 . Their permissible values are shown in the description of "5. Installation" of the each series.

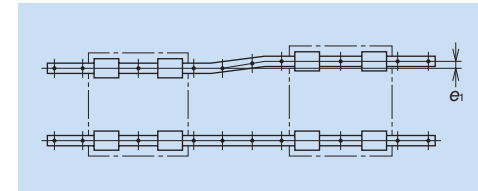

Fig. 10.5

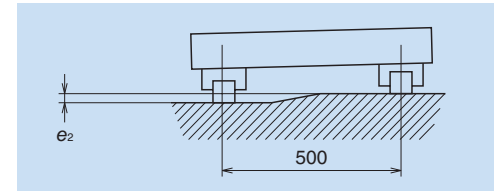

Fig. 10.6

(4) Running accuracy and the influence of even-off effect

When mounting on a machine base, the linear guide is affected by the flatness of the mounting surface. However, in the case of two-rail/four-side specification, which is most widely used, the straightness as a table unit is generally less than the straightness as a single component. This is due to the even-off effect generated by the shorter table stroke,

compared to the rail length, as well as by interaction between the rails and slides.

Fig. 10.9 shows an actually measured straightness of the table which uses NSK linear guides. In this case, the final straightness of the table is about 1/5 of the straightness of the mounting surface.

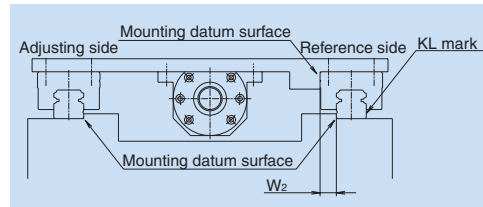

Fig. 10.7

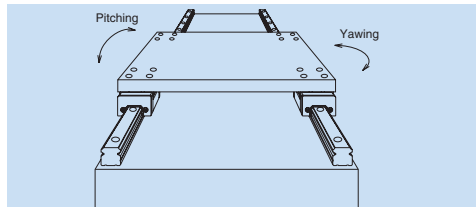

Fig. 10.8

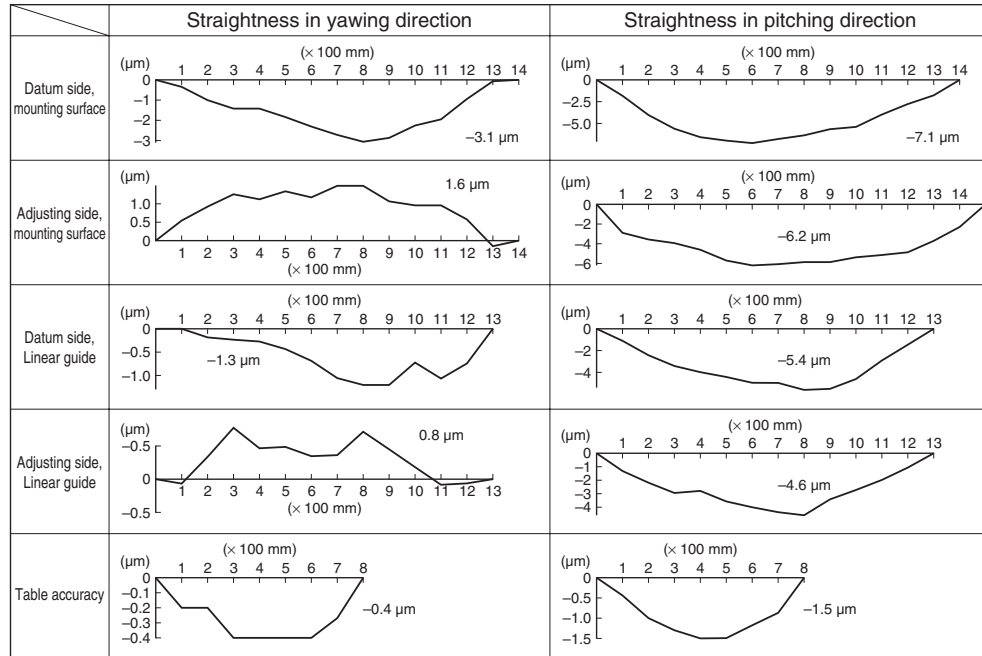

Fig. 10.9 Straightness of the table equipped with linear guide

3. Installation

(1) Shoulder height of the mounting surface of the machine base and corner radius r

Fig. 10.10 and 10.11, show shoulder height of the mounting surface of the machine base and the size of corner radius. These figures are relevant when the linear guide is pressed to the shoulder of the machine base or table (the raised section from where the mounting surface begins), and horizontally secured to it. Recommended sizes are shown in the clause of "Shoulder height and corner radius r" of each series introduction.

The shoulder should be thick (wide) enough, so it is not deformed by the pressing force.

(2) Tightening torque of the bolt

Table 10.4 shows tightening torque of the bolt when the rail is secured to the fixture of race way grinding machine.

Apply same torque in this table when securing the rail to the machine base. Equal accuracy at the time of grinding can be obtained.

Table 10.4 Bolt tightening torque (Bolt material: High carbon chromium steel)

Unit: N·m			
Bolt size	Tightening torque	Bolt size	Tightening torque
M2.3	0.38	M10	43
M2.5	0.58	M12	76
M3	1.06	M14	122
M4	2.5	M16	196
M5	5.1	M18	265
M6	8.6	M22	520
M8	22	—	—

(3) Installation procedures

There are two installation ways depending on the accuracy requirement.

- a. Installation with high accuracy
- b. Accuracy is not high, but easy to install

For both methods, wipe off the rust preventive oil applied to the linear guide. Remove burrs and small bumps on the machine base and table mounting surface with an oilstone (Fig. 10.12).

Apply machine oil or similar oil with low viscosity to the mounting surface to increase the rust preventive effect.

Linear guides are precision products. Handle them with care.

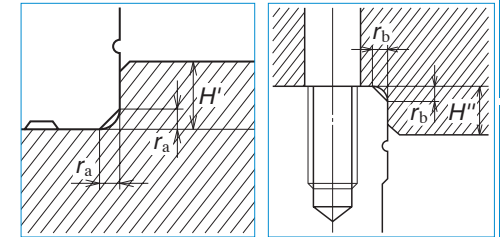

Fig. 10.10 Shoulder for the rail datum surface

Fig. 10.11 Shoulder for the slide datum surface

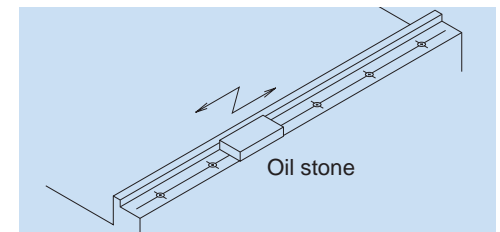

Fig. 10.12

1) Highly accurate installation

A) Rail installation procedures

a) When the machine base has a shoulder for the reference side rail.

[1] Confirm that the rail is reference side rail, and the datum surface of the rail comes to face to face with the shoulder of the machine base. Keep the slides on the rail, and carefully place the rail on the machine base on its mounting surface. Loosely tighten the bolts.

At this time, press the rail from sideways to make the rail tightly contact to the shoulder of the machine base. When using a shoulder plate, refer to **Table 10.4** for the bolt tightening torque (**Fig. 10.13**).

Refer to "4. Various methods to press linear guide sideways."

[2] For final tightening of the bolts to secure the rail, tighten the bolt on either end of the rail, then proceed to other end.

If the datum surface is on the left side as shown in **Fig. 10.14**, tighten the bolt at the farthest end first, then proceed to the near end.

This way, creates a bolt rotating force that presses the rail against the shoulder. (Therefore, the rail is pressed sufficiently tight against the shoulder by merely pressing the rail by hand. However, if there is a possibility applying a lateral impact load, it is necessary to use a shoulder plate to prevent the rail from slipping.)

[3] If the mounting surface of the machine base where the adjusting side rail is installed also has a shoulder, repeat the steps [1] - [2].

[4] If there is no shoulder on the mounting surface of the machine base for the adjusting side rail: Secure a measuring table to the slides of the reference side rail (**Fig. 10.15**). Use this to adjust the parallelism of the adjusting side rail. Check parallelism of the adjusting side rail with a dial indicator from one end of the rail, tightening the bolts one by one.

The measuring table is more stable if secured to two slides, but one slides is sufficient. Parallelism between two rails can also be checked by the same method in **Fig. 10.15** when there is a shoulder on the surface where the adjusting side rail is installed.

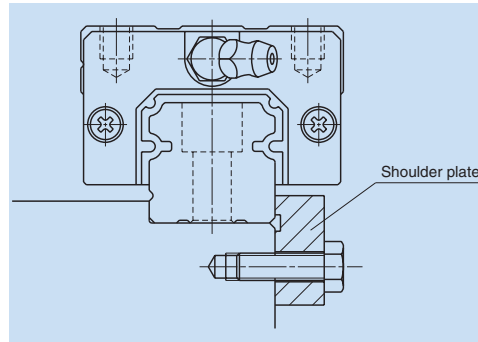

Fig. 10.13 Pressing the rail from sideways

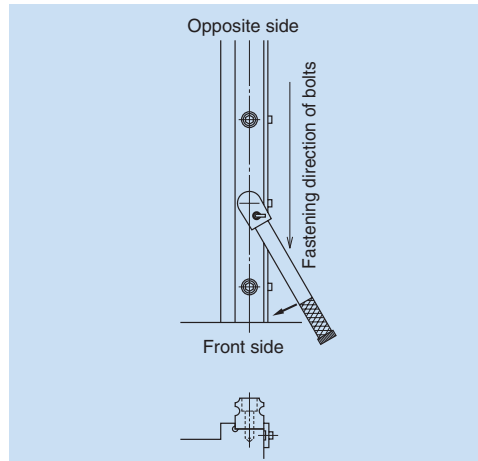

Fig. 10.14 Rail installation

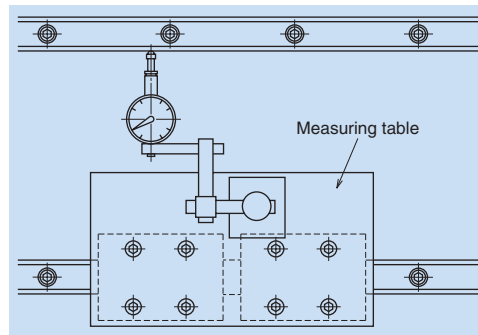

Fig. 10.15 Measuring parallelism

b) When the machine base does not have a shoulder on the side where the reference side rail is installed

[1] Carefully place the reference side rail on its mounting surface of the machine base. Loosely tighten the bolts. Do not tighten the bolts all the way, but stop tightening when the bolt enters halfway into the bolt hole. This makes the proceeding steps easier.

[2] Place the straight edge almost parallel to the reference side rail which is temporarily secured by the bolts. (At both ends of the rail and straight edge, the distance between them shall be almost same.)

[3] Once the position of the straight edge is determined, use it as the reference. With a dial indicator, check parallelism with the rail, and adjust the rail if necessary. Then tighten the bolts.

Ensure that the straight edge does not move while the bolts are being tightened.

This procedure should be carried out starting from one end of the rail to the other end (**Fig. 10.16**).

[4] Finally tighten all bolts with specified torque.

[5] There are two ways for installation of adjusting side rail:

1. Based on the straight edge which is used for reference side rail installation
2. Based on the reference side rail which is installed prior to the adjusting side rail.

In both cases, use a dial indicator to measure parallelism.

Other procedures are the same as [1] - [4] above, and the [4] for the case where there is a shoulder on the machine base.

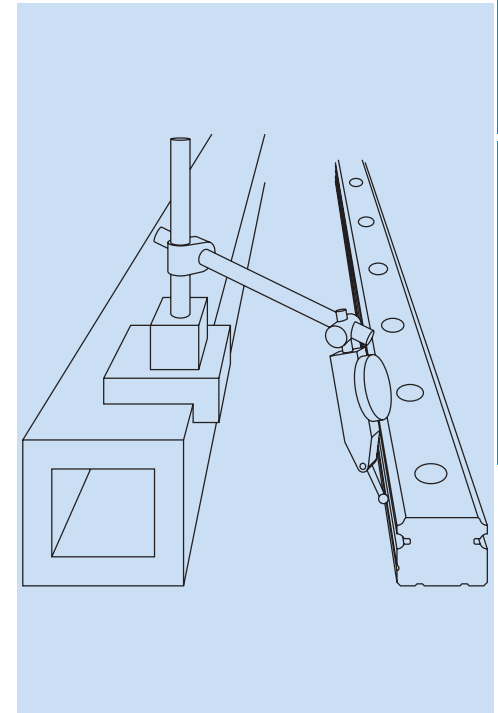

Fig. 10.16

B) Procedures for slide installation

a) When the table has a shoulder

[1] Arrange the slides so that locations match to their mounting section of the table. Carefully place the table on the slides. Loosely tighten all bolts.

[2] While pressing the table from sideways, further tighten the bolts which secure the slides on the reference side, so the table shoulder and the slide's mounting datum surface are sufficiently tightly pressed.

If a shoulder plate is provided, first tighten the bolts of the plate, then further tighten the bolts to the slides (**Fig. 10.17**).

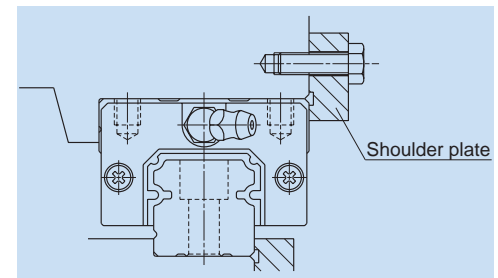

Fig. 10.17 Pressing slide from sideways

- [3] Then, further tighten the bolts for slides on the adjusting side rail.
Move the table by hand to confirm that there is no abnormality such as excessive friction force during stroking. (This confirms that the correct installation steps were taken.)
- [4] Finally, tighten all bolts with standard torque.

b) When table does not have a shoulder

- [1] Arrange the slides so that locations match to their mounting section of the table. Carefully place the table on the slides. Loosely tighten bolts to secure the slides.
- [2] Since the table does not have a shoulder, immediately tighten the bolts further to secure slides.
- [3] Move the table by hand to confirm that there is no abnormality. Finally, tighten all bolts with the specified torque.

2) Easy installation

- [1] Carefully place the reference side rail on the machine base. Then tighten the bolts to the specified torque.
- [2] Loosely tighten the bolts on the adjusting side rail.
- [3] Tighten the slides on the reference side rail and one slide on the adjustment side rail with the specified torque. Leave the rest of the slide on the adjusting side rail loosely tightened (**Fig. 10.18**).
- [4] While moving the table with each pitch of the bolt for rail: With the specified torque, tighten the rail mounting bolt which is located immediately adjacent to the slide on the adjusting side rail that had been firmly tightened.
- Take this procedure from one end to the other.
- [5] Return the table to the original position once. Then, tighten the rest of the slides on the adjusting side to the specified torque. By the same procedure as in [4], tighten the rest of the rail mounting bolts to the specified torque. Move the table to check any abnormality such as large friction force.

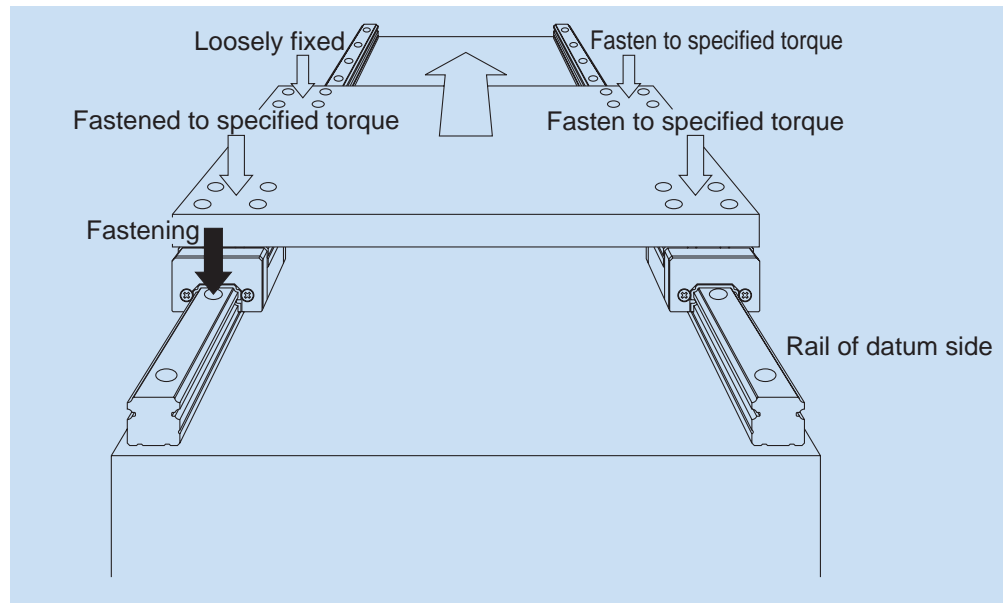

Fig. 10.18 Easy installation

(4) Various methods to press linear guide sideways

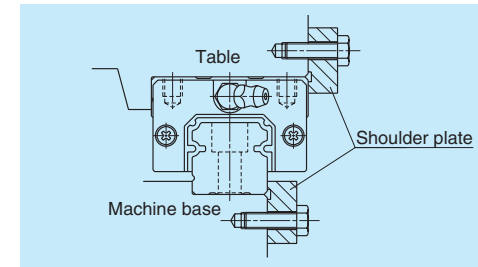

Fig. 10.19 Recommended method

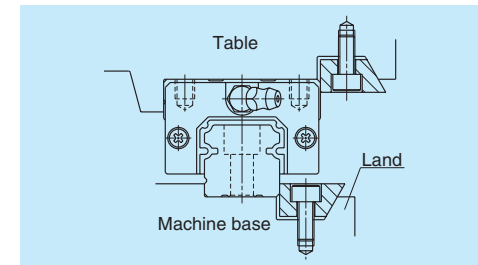

Fig. 10.20 Installation that requires caution

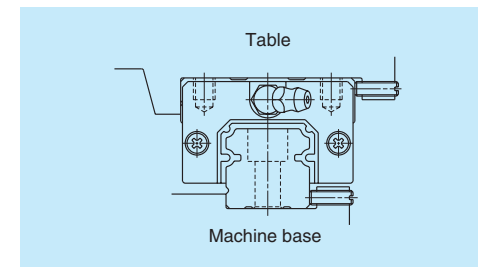

Fig. 10.21

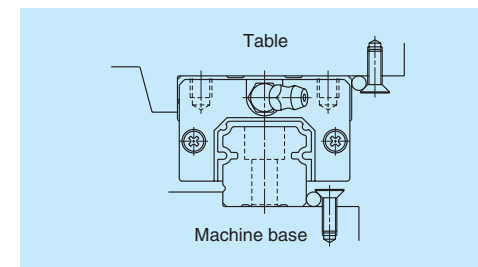

Fig. 10.22

- This method is most widely used, and generally recommended. The slides and the rail should protrude slightly from the sides of the table and the machine base. The shoulder plate should have a recess, so that the corners of the rail and slide do not touch the shoulder plate.

- A tapered block is squeezed in. However, the slightest tightening of the bolt generates a large pressing force to the side. Too much tightening may cause the rail to deform, or the land (shown in the figure left) to warp to the right. This method requires caution.

- The bolt that presses rail must be thin due to limited space.

- Press a needle roller with a taper section of the head of a slotted pan head screw. Watch out for the position of the screw.

4. Assembly random-matching type linear guide

- Slides of random-matching type are assembled on a provisional rail (an inserting tool) when it is delivered (Fig. 10.23).
- NSK standard grease is packed into the slide, allowing immediate use.

Assembly procedures of a random-matching type linear guide

Follow steps as described below.

- (1) Wipe off the rust preventive oil from the rail and slide.
- (2) Please match a groove mark for the datum surface of slide and rail to set a desired assembling state W_2 or W_3 .
- (3) Align the provisional rail to the rail in the bottom and side surfaces. Press the provisional rail lightly against the rail, and move the slide over the rail (Fig. 10.23).

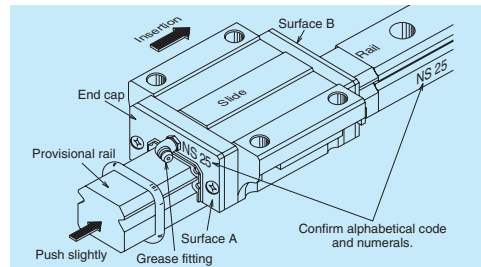

Fig. 10.23 Inserting slide into the rail

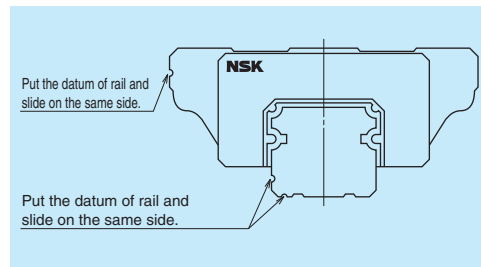

Fig. 10.24

5. Butting rail specification

- A rail which requires the length that exceeds the machine capacity manufactured maximum length comes in butting specification.
- The rails with butting specification are marked with alphabet (A, B, C ...) and an arrow on the opposite side of the mounting datum surface. Use the alphabets and arrows for assembly order and direction of the rail (Fig. 10.25).
- The random-matching rails for butting specification are only marked with the arrows.
- The pitch of the rail mounting hole on the butting section should be as F in Fig. 10.26.
- When two rails are used in parallel, the butted sections should not align. This is to avoid change in the running accuracy of the table at the butted sections.
- We recommend shifting the butting sections more than the length of a slide. If the higher running accuracy is required, consider installing the slides into the table so that they do not simultaneously pass the butting sections.

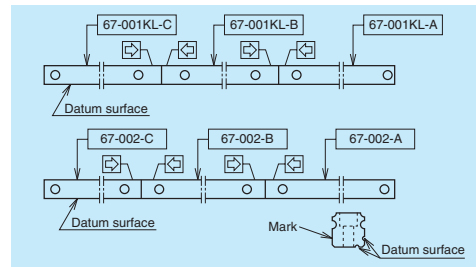

Fig. 10.25

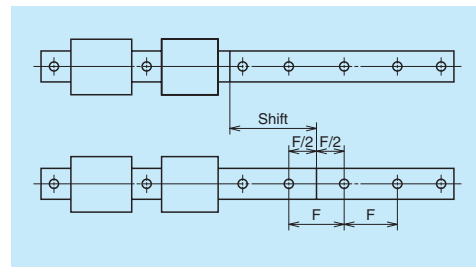

Fig. 10.26

6. Handling preloaded assembly

- In case of the preloaded assembly (not random-matching type), do not remove slides from the rail as a general rule.
- If it is unavoidable to remove slides from the rail, make certain to use a provisional rail (a jig used to insert a slide to the rail) as shown in Fig. 10.27.
- The provisional rails for each series and sizes are available.
- Pay due attention to the assembly mark when returning the slide back to the rail. Follow the cautions described below.

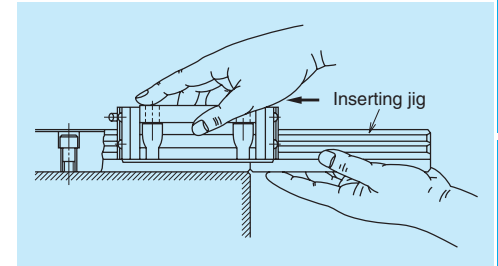

Fig. 10.27

Mark for assembling ball slide and rail

- Rails of preloaded assembly (not random-matching type) are marked with a reference number and a serial number on the opposite of the datum surface.
- Slides to be combined are also marked with the same serial number (the reference number is not marked).
- Furthermore, slides are marked with an arrow. Slides should be positioned with their arrows facing each other.
- In case that the slides had to be removed from the rail, confirm their serial numbers and the directions of arrows for re-assembly (Fig. 10.28).
- When two or more rails are used in a single set, serial numbers are in sequence if their reference numbers are the same. The linear guide with smallest serial number has the "KL" mark (Fig. 10.29).
- When two or more rails of different reference number are used in a single set, the rails and slides have the same serial number. In this case, when slides are removed from the rail, it is unclear which rail each slide was previously installed on. When removing ball slides from the rail for an unavoidable reason (Fig. 10.30), sufficient precaution is required.

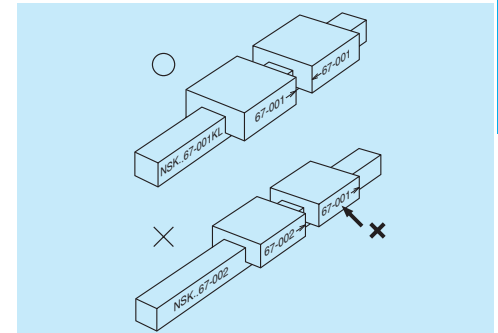

Fig. 10.28

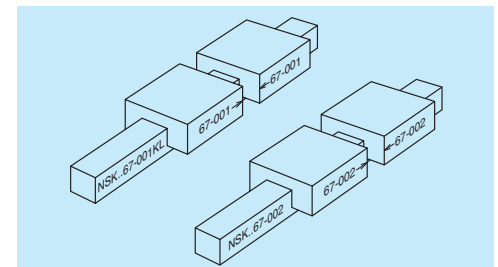

Fig. 10.29 When two rails have the same reference number

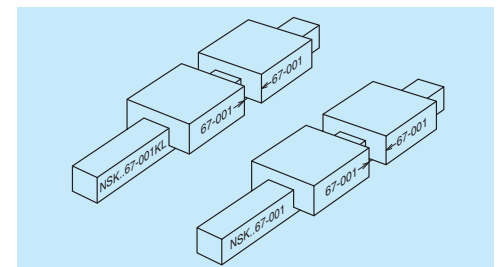

Fig. 10.30 When two rails have different reference number

A-3-11 Drills to Select Linear Guide

1. Single axis material handling system

This section explains the selection of linear guide, life calculation, and deformation at load acting point for a single axis material handling system equipped with linear guides.

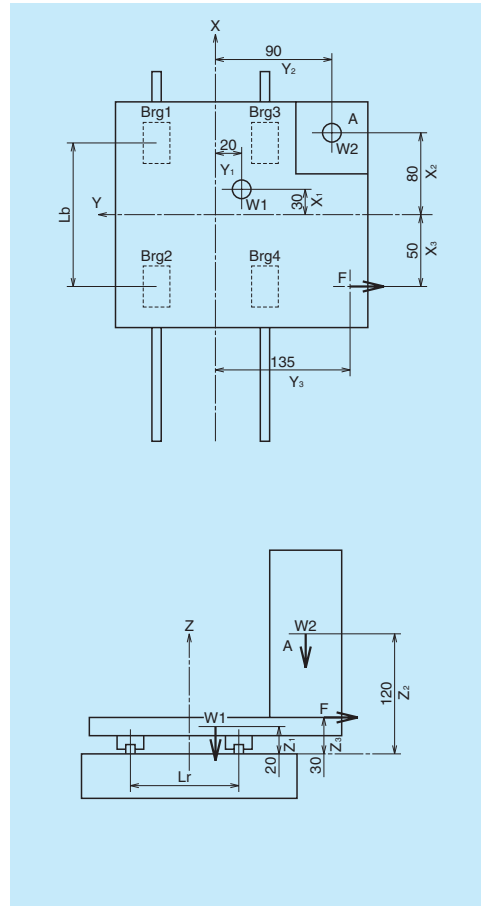

Fig. 11.1 Single axis material handling system

The work load is applied only to one way of stroke. Assume that the load is acting in full stroke as the condition of acting load is unknown.

Specification of the single axis material handling system

Table weight W1 : 150 (N)
 Weight of the work W2 : 200 (N)
 Acting load F : 200 (N)

Ball slide span L_b : 100 (mm)
 Rail span L_r : 90 (mm)

Load point coordinates from the table center (mm)

Load	X axis	Y axis	Z axis
W1	30	-20	20
W2	80	-90	120
F	-50	-135	30

Stroke: 1 000 mm
 (1 cycle: 2 000 mm)

Environment : 10 – 30 (°C)
 Travel speed : 12 (m/min)
 Time to reach travel speed : 0.25 (sec)
 Operating hour : 16 (hr/day)

(1) Selection of linear guide model

Select a type of linear guide from "A-1-2 Structure and Characteristics of Linear Guide." Since this material handling system has two rails and four ball slides, **NH**, **NS**, and **PU Series** are suitable.

Here, we temporary select PU15 because of the dimensions of mounting space.

(2) Calculating life

Calculate life of the selected PU15AL based on "A-3-2 Rating Life and Basic Load Rating."

Linear guide PU15AL

Basic dynamic load rating C_{100} : 4 400 (N)
 Basic static load rating C_0 : 6 600 (N)

Load conditions of the linear guide

Table weight W1 : 150 (N)
 Weight of the work W2 : 200 (N)
 Applied load F : 200 (N)
 Rail span L_r : 90 (mm)
 Ball slide span L_b : 100 (mm)

From the time to reach travel speed and the travel speed, the table acceleration is 0.8 m/sec². Therefore, it is not necessary to take into account inertial force brought about by the table mass.

Calculation of the load applied to ball slide

Calculate two occasions:

1. There is the work mounted on the table.
2. No work mounted on the table.

From **Pattern 4** on page A19 in **Table 2.2**

When a work is mounted on the table Vertical loads

$$M1 = \sum_{j=1}^n (F_{yj} \cdot Z_{yj}) + \sum_{k=1}^n (F_{zk} \cdot Y_{zk})$$

$$= F \cdot Z_3 + W1 \cdot Y_1 + W2 \cdot Y_2$$

$$= -200 \times 30 + 150 \times (-20) + 200 \times (-90)$$

$$= -27\ 000 \text{ (N}\cdot\text{mm)}$$

$$M2 = \sum_{i=1}^n \{F_{xi} \cdot (Z_{xi} - Z_b)\} + \sum_{k=1}^n (F_{zk} \cdot X_{zk})$$

$$= W1 \cdot X_1 + W2 \cdot X_2$$

$$= 150 \times 30 + 200 \times 80$$

$$= 20\ 500 \text{ (N}\cdot\text{mm)}$$

$$F_{r1} = \sum_{k=1}^n \frac{F_{zk}}{4} + \frac{M1}{2 \cdot L} + \frac{M2}{2 \cdot \ell}$$

$$= \frac{W1 + W2}{4} + \frac{M1}{2 \cdot L_r} + \frac{M2}{2 \cdot L_b}$$

$$= \frac{150 + 200}{4} + \frac{-27\ 000}{2 \times 90} + \frac{20\ 500}{2 \times 100}$$

$$= 40 \text{ (N)}$$

Similarly

$$F_{r2} = -165 \text{ (N)}$$

$$F_{r3} = 340 \text{ (N)}$$

$$F_{r4} = 135 \text{ (N)}$$

Lateral loads

$$M3 = -\sum_{i=1}^n \{F_{xi} \cdot (Y_{xi} - Y_b)\} + \sum_{j=1}^n (F_{yj} \cdot X_{yj})$$

$$= F \cdot X_3$$

$$= -200 \times (-50)$$

$$= 10\ 000 \text{ (N}\cdot\text{mm)}$$

$$F_{s1} = F_{s3} = \frac{\sum_{j=1}^n F_{yj}}{4} + \frac{M3}{2 \cdot l}$$

$$= \frac{F}{4} + \frac{M3}{2L_b}$$

$$= \frac{-200}{4} + \frac{10\,000}{2 \times 100}$$

$$= 0 \text{ (N)}$$

Lateral loads

$$M3 = -\sum_{i=1}^n \{F_{xi} \cdot (Y_{xi} - Y_b)\} + \sum_{j=1}^n (F_{yj} \cdot X_{yj})$$

$$= F \cdot X_3$$

$$= -200 \times (-50)$$

$$= 10\,000 \text{ (N} \cdot \text{mm)}$$

$$F_{s1} = F_{s3} = \frac{\sum_{j=1}^n F_{yj}}{4} + \frac{M3}{2 \cdot l}$$

$$= \frac{F}{4} + \frac{M3}{2 \cdot L_b}$$

$$= \frac{-200}{4} + \frac{10\,000}{2 \times 100}$$

$$= 0 \text{ (N)}$$

Similarly

$$F_{s2} = F_{s4} = -100 \text{ (N)}$$

No work mounted on the table

Vertical load

$$M1 = \sum_{j=1}^n (F_{yj} \cdot Z_{yj}) + \sum_{k=1}^n (F_{zk} \cdot Y_{zk})$$

$$= F \cdot Z_3 + W1 \cdot Y_1$$

$$= -200 \times 30 + 150 \times (-20)$$

$$= -9\,000 \text{ (N} \cdot \text{mm)}$$

Similarly

$$F_{s2} = F_{s4} = -100 \text{ (N)}$$

For calculation, take into consideration the positive or negative signs (+ or -) for load point coordinates.

$$M2 = \sum_{i=1}^n \{F_{xi} (Z_{xi} - Z_b)\} + \sum_{k=1}^n (F_{zk} \cdot X_{zk})$$

$$= W1 \cdot X_1$$

$$= 150 \times 30$$

$$= 4\,500 \text{ (N} \cdot \text{mm)}$$

$$F_{r1} = \frac{\sum_{k=1}^n F_{zk}}{4} + \frac{M1}{2 \cdot L} + \frac{M2}{2 \cdot l}$$

$$= \frac{W1}{4} + \frac{M1}{2 \cdot L_r} + \frac{M2}{2 \cdot L_b}$$

$$= \frac{150}{4} + \frac{-9\,000}{2 \times 90} + \frac{4\,500}{2 \times 100}$$

$$= 10 \text{ (N)}$$

Similarly

$$F_{r2} = -35 \text{ (N)}$$

$$F_{r3} = 110 \text{ (N)}$$

$$F_{r4} = 65 \text{ (N)}$$

Calculation of dynamic equivalent load

Use "A-3-2.2 3. Calculation of dynamic equivalent load."

It matches Position 4 in "Table 2.3 Loads in the arrangement of linear guides." Ball slide loads that must be considered are vertical and lateral direction loads.

In case of PU15AL,

Vertical direction dynamic equivalent load

$$F_r = F_r$$

Lateral direction dynamic equivalent load

$$F_{e0} = F_r \cdot \tan \alpha = F_r$$

Use the formula for full dynamic equivalent load (page A23) to calculate F_e .

Results are shown in the table below.

Unit: N

Work mounted	Slide1	Slide2	Slide3	Slide4
$F_r (F_{r1} - F_{r4})$	40	-165	340	135
$F_{s0} (F_{s1} - F_{s4})$	0	-100	0	-100
F_e	40	215	340	185
No work mounted	Slide1	Slide2	Slide3	Slide4
$F_r (F_{r1} - F_{r4})$	10	-35	110	65
$F_{s0} (F_{s1} - F_{s4})$	0	-100	0	-100
F_e	10	118	110	133

Based on the results of calculations, a ball slide that bears the maximum dynamic equivalent load shall be taken as the representative of the linear guides for further life calculation. For this case, we take the Slide3.

Calculation of mean effective load

Based on "A-3-2.2 4. Calculation of mean effective load," calculate from the largest full dynamic equivalent loads.

Therefore;

Work mounted $F_{e1} = 340 \text{ (N)}$

No work mounted $F_{e2} = 110 \text{ (N)}$

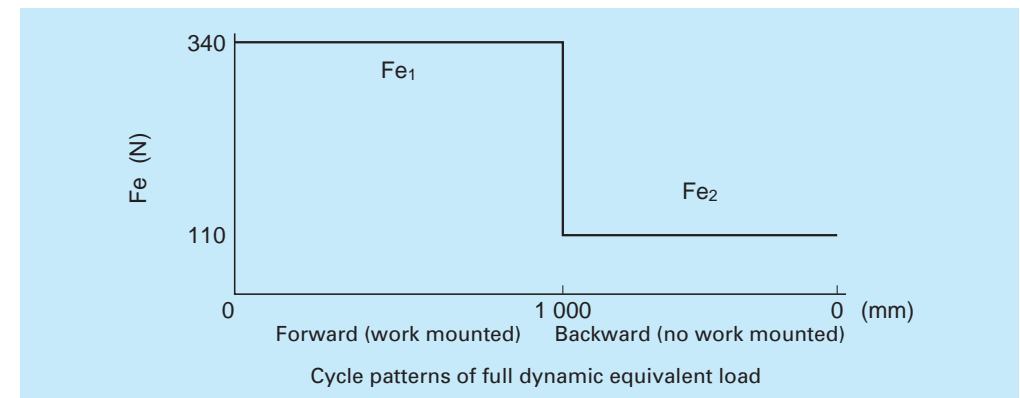

From the cycle pattern, the mean effective load matches the case "(1) When load and running distance vary stepwise." Therefore, use the following formula.

Assuming that L is: $L = L_1 + L_2$.

$$Fm = \sqrt[3]{\frac{1}{L}(F_{e1}^3 L_1 + F_{e2}^3 L_2)}$$

$$= \sqrt[3]{\frac{1}{2\,000}(340^3 \times 1\,000 + 110^3 \times 1\,000)}$$

$$= 273 \text{ (N)}$$

Determine various coefficients

Determine applicable coefficients from "A-3-2.2

5. Various coefficients."

Load factors

Use conditions are: Travel speed, 12 m/min; Acceleration, 0.8 m/sec² (0.082 G). As the load factor f_w is in the range of 1.0 to 1.5, use common value $f_w = 1.2$.

Hardness coefficient

The hardness of NSK linear guides is HRC58 to 62. Use a hardness coefficient $f_H = 1$ and take the value of basic dynamic load rating as it is.

Calculate rating life

Use "A-3-2.2 6. Calculation of basic rating life."

The basic dynamic load rating (C_{100}) of linear guide PU15AL : 4 400 (N)

Mean effective load F_m : 273 (N)

Load factor f_w : 1.2

Hardness coefficient f_H : 1

$$\text{Rating fatigue life } L = 100 \times \left(\frac{f_H \cdot C_{100}}{f_w \cdot F_m} \right)^3$$

$$= 100 \times \left(\frac{1 \times 4\,400}{1.2 \times 273} \right)^3$$

$$= \text{approximately } 242\,280 \text{ (km)}$$

Travel speed, 12 m/min; Operating hours, 16 hr/day.

Convert the above rating fatigue life into hours:

$$\frac{242\,280 \times 1\,000}{12 \times 60 \times 16} = \text{approximately } 21\,030 \text{ (days)}$$

Examine static load

Based on "A-3-2.2 7. Examination of static load," find out on which ball slide the static equivalent load P_0 becomes largest.

The basic static load rating (C_0) of linear guide PU15AL: 6 600 (N)

Ball slide No. 3 bears the largest load.

P_0 at this time:

$$P_0 = F_r + F_s = 340$$

Therefore, static permissible load coefficient f_s is:

$$f_s = \frac{C_0}{P_0} = \frac{6\,600}{340} = 19.4$$

There is no problem at this value.

(3) Selection of accuracy grade and preload

Based on "A-3-4 3. Application examples of accuracy," select accuracy grade PN and preload Z1 for material handling system.

(4) Calculation of deformation

Calculate deformation by the weight of the mounted work W_2 . From "Rigidity of PU series," the rigidity of linear guide PU15AL with Z1 preload is:

$$K_s = K_r = 45 \text{ (N/}\mu\text{m)} = 45\,000 \text{ (N/mm)}$$

Deformation by the weight of the mounted work W_2 can be obtained as the difference in deformation when W_2 applies or does not apply.

From Pattern 4 in Table 2.2 (page A19)

Work mounted:

$$\delta_{x1} = Y_d \cdot \frac{F_{s2} - F_{s1}}{L_b \cdot K_s} + Z_d \cdot \frac{F_{r1} - F_{r2}}{L_b \cdot K_r}$$

$$= -90 \times \frac{-100 - 0}{100 \times 45\,000} + 120 \times \frac{40 - (-165)}{100 \times 45\,000}$$

$$= 0.0075 \text{ (mm)} = 7.5 \text{ (}\mu\text{m)}$$

Similarly, $\delta_{y1} = -0.0082 \text{ (mm)} = -8.2 \text{ (}\mu\text{m)}$

$$\delta_{z1} = 0.0123 \text{ (mm)} = 12.3 \text{ (}\mu\text{m)}$$

No work mounted:

$$\delta_{x2} = Y_d \cdot \frac{F_{s2} - F_{s1}}{L_b \cdot K_s} + Z_d \cdot \frac{F_{r1} - F_{r2}}{L_b \cdot K_r}$$

$$= -90 \times \frac{-100 - 0}{100 \times 45\,000} + 120 \times \frac{10 - (-35)}{100 \times 45\,000}$$

$$= 0.0032 \text{ (mm)} = 3.2 \text{ (}\mu\text{m)}$$

Similarly, $\delta_{y2} = -0.0023 \text{ (mm)} = -2.3 \text{ (}\mu\text{m)}$

$$\delta_{z2} = 0.0039 \text{ (mm)} = 3.9 \text{ (}\mu\text{m)}$$

Therefore, the difference in deformation by whether there is a mounted work or not is as follows:

$$\delta_x = \delta_{x1} - \delta_{x2} = 7.5 - 3.2 = 4.3 \text{ (}\mu\text{m)}$$

$$\delta_y = \delta_{y1} - \delta_{y2} = -8.2 - (-2.3) = -5.9 \text{ (}\mu\text{m)}$$

$$\delta_z = \delta_{z1} - \delta_{z2} = 12.3 - 3.9 = 8.4 \text{ (}\mu\text{m)}$$

2. Machining center

The following is a calculation example of a horizontal type machining center. Arrangements of each axis are shown in Fig. 11.2 (front view) and Fig. 11.3 (side view).

Operating conditions

Dimensions and load conditions are:

X axis column's weight	W_x : 7 500 (N)
Y axis spindle head's weight	W_y : 2 500 (N)
Z axis table's weight	W_z : 5 500 (N)
X axis rail span	XL : 450 (mm)
X axis ball slide span	XL_b : 310 (mm)
Y axis rail span	YL : 410 (mm)
Y axis ball slide span	YL_b : 308 (mm)
Z axis rail span	ZL : 660 (mm)
Z axis ball slide span	ZL_b : 420 (mm)

X axis stroke : 400 (mm)

Y axis stroke : 350 (mm)

Z axis stroke : 500 (mm)

Average rapid traverse speed : 15 (m/min)

[Max. 30 (m/min)]

Starting accelerating speed : 1 (G)

Milling speed : 2.5 (m/min)

Drilling speed : 0.8 (m/min)

Cutting load

Milling process $F_x = F_y = 1\,000 \text{ (N)}$

Drilling process $F_z = 3\,000 \text{ (N)}$

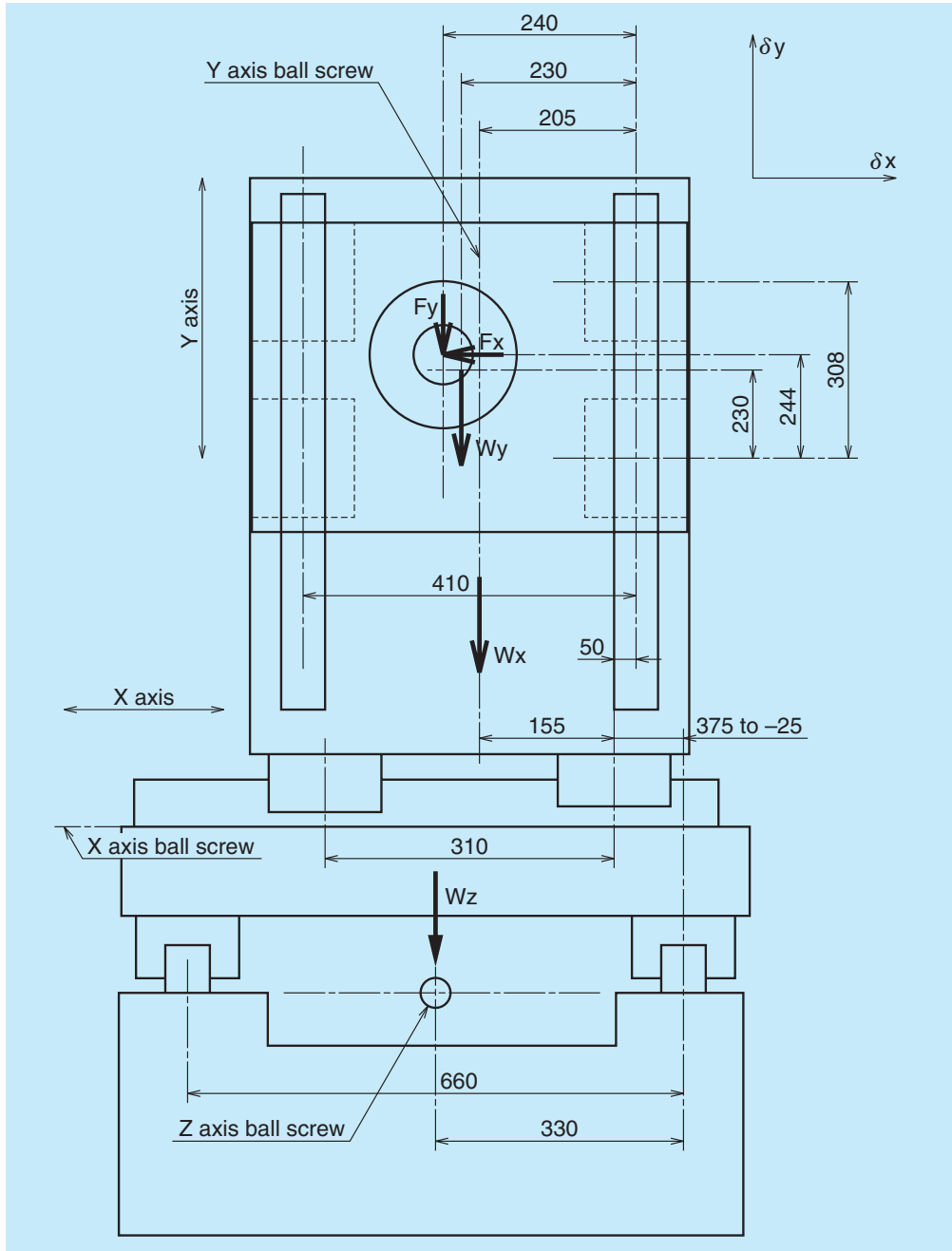

Fig. 11.2 Machining center (front view)

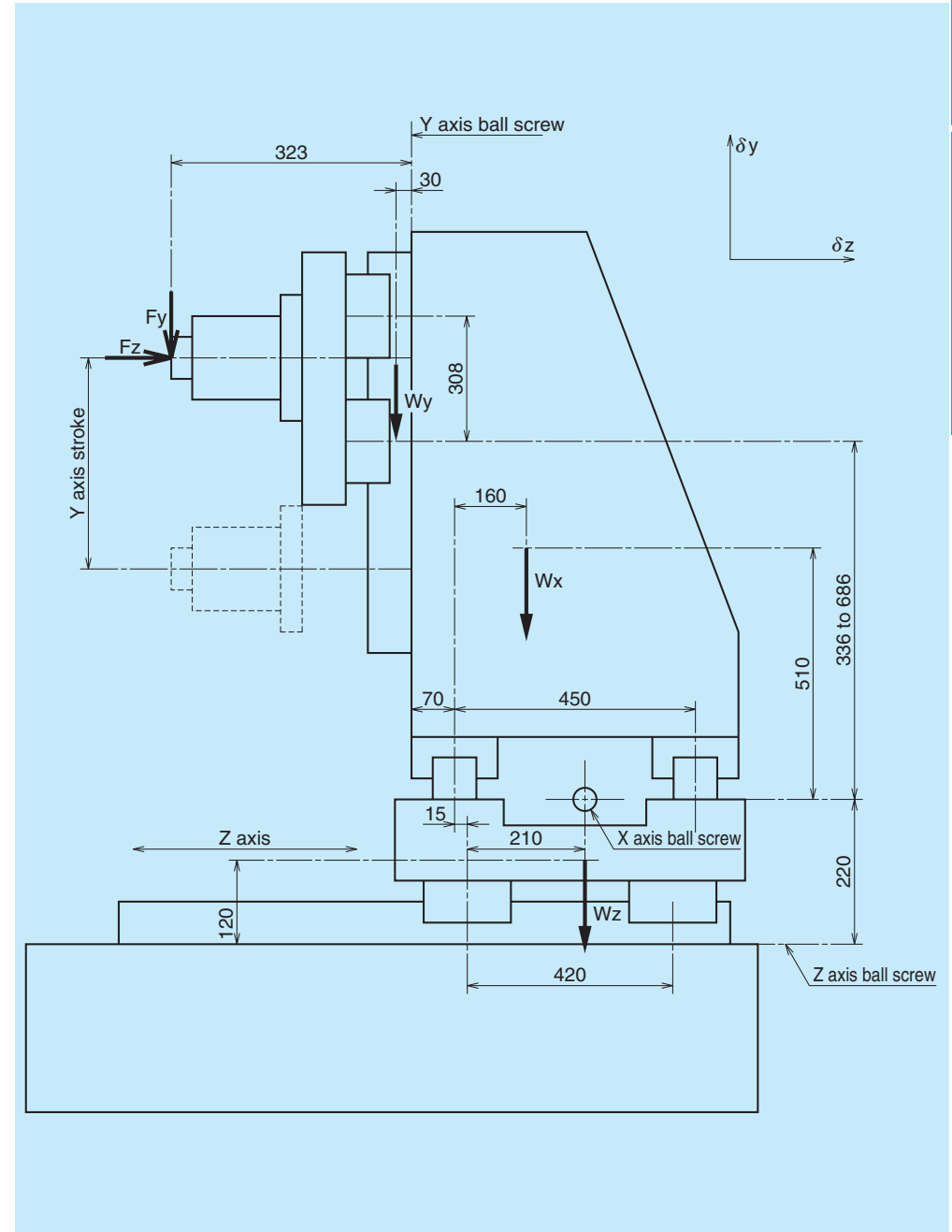

Fig. 11.3 Machining center (side view)

(1) Selection of linear guide model

From the operating conditions, the linear guide should be LA Series which is suitable for the machining center.

Select below temporarily from shaft diameter of ball screw:

- X axis LA55
- Y axis LA35
- Z axis LA65

(2) Selection of accuracy grade and preload

For machining center, select accuracy grade P5 and preload Z3.

Axis	Load direction	Slide1	Slide2	Slide3	Slide4
X axis	Vertical direction F_r	1 156	955	4 045	3 844
	Lateral direction F_s	0	0	0	0
Y axis	Vertical direction F_r	122	-122	122	-122
	Lateral direction F_s	102	-102	102	-102
Z axis	Vertical direction F_r	765	3 860	3 890	6 985
	Lateral direction F_s	0	0	0	0

Unit: N

In case of milling process: $F_x = F_y = 1\ 000$ (N)

Similarly,
 X axis: Loads to be considered W_x, W_y, F_x , and F_y
 Y axis: Loads to be considered W_y, F_x , and F_y
 Z axis: Loads to be considered W_x, W_y, W_z, F_x , and F_y

Axis	Load direction	Slide1	Slide2	Slide3	Slide4
X axis	Vertical direction F_r	2 277	-1 039	6 539	3 224
	Lateral direction F_s	997	-997	997	-997
Y axis	Vertical direction F_r	252	-1 040	1 040	-252
	Lateral direction F_s	54	-554	54	-554
Z axis	Vertical direction F_r	-771	3 796	4 453	9 020
	Lateral direction F_s	486	-986	486	-986

Unit: N

(3) Calculation of life expectancy

Examination shall be done in three cases, no cutting load, milling process, and drilling process.

Inertial force associated with the starting acceleration is not considered in this case. However, it must be calculated for more accurate figures.

Calculation of the loads that apply to the ball slide

In case of no cutting load: $F_x = F_y = F_z = 0$

Calculate load on X, Y, Z axes using "Table 2.2" in "A-3-2.2 2. Calculating load to a ball slide."

X axis: Loads to be considered W_x and W_y
 Y axis: Loads to be considered W_y
 Z axis: Loads to be considered W_x, W_y , and W_z

The table below shows the calculation of each load coordinates at stroke end which imposes most strict condition.

In case of drilling process: $F_z = 3\ 000$ (N)

X axis: Loads to be considered W_x, W_y , and F_z
 Y axis: Loads to be considered W_y and F_z
 Z axis: Loads to be considered W_x, W_y, W_z , and F_z

The table below shows calculation of each load coordinates at a stroke end which imposes most strict condition.

Axis	Load direction	Slide1	Slide2	Slide3	Slide4
X axis	Vertical direction F_r	4 256	4 055	945	744
	Lateral direction F_s	919	581	919	581
Y axis	Vertical direction F_r	305	938	561	1 195
	Lateral direction F_s	102	-102	102	-102
Z axis	Vertical direction F_r	4 872	-247	7 997	2 878
	Lateral direction F_s	839	-839	839	-839

Unit: N

Calculation of dynamic equivalent load

Next, find dynamic equivalent load under each cutting condition. From "Table 2.3" in "A-3-2.2 3. Calculation of dynamic equivalent load," the necessary loads, F_r and F_{se} are, as the linear guide model is LA Series, obtained as follows.

Vertical dynamic equivalent load

$F_r = F_r$

Lateral dynamic equivalent load

$F_{se} = F_s \cdot \tan \alpha = F_s$

From the above, calculate F_e using formulas for full dynamic equivalent loads shown in page A23. From calculation, the largest full dynamic equivalent loads are as follows.

Axis	Largest full dynamic equivalent load F_e (N)		
	No cutting load	For milling process	For drilling process
X axis	4 045	7 038	4 716
Y axis	173	1 317	1 246
Z axis	6 985	9 513	8 417

Calculation of full dynamic equivalent load taking account of preload

It is necessary to include the amount of preload for the calculation of rating life when Z3 preload is specified. Consider each preload and calculate full dynamic equivalent load. Calculate F_{ep} using formulas in "A-3-3 6. Load and rating life when the preload is taken into

account".

Preload P (X axis linear guide LA55): 8 100 (N)

Preload P (Y axis linear guide LA35): 3 450 (N)

Preload P (Z axis linear guide LA65): 13 800 (N)

From the above, the full dynamic equivalent loads taking preload into account are smaller than the load at which preload is relieved.

Axis	Largest full dynamic equivalent load F_e (N)		
	No cutting load	For milling process	For drilling process
X axis	10 336	12 104	10 724
Y axis	3 542	4 171	4 131
Z axis	17 663	19 138	18 494

Calculation of mean effective load

Calculate the mean effective loads from full dynamic equivalent loads. If duty cycle in the cutting process is not clear, set the mean effective load to 70% of the largest full dynamic equivalent load in all processes.

Therefore,

X axis: $12\ 104 \times 0.7 = 8\ 473$ (N)

Y axis: $4\ 171 \times 0.7 = 2\ 920$ (N)

Z axis: $19\ 138 \times 0.7 = 13\ 397$ (N)

Determine various coefficients

Determine them based on "A-3-2.2 5. Various coefficients."

For this case the factors are following.

Load coefficient f_w : 1.5

Hardness coefficient f_H : 1

Calculation of rating life

Based on the calculated loads and various coefficients, calculate the rating life from "A-3-2.2 6. Calculation of rating life."

Basic dynamic load rating C_{100}

(X axis linear guide LA55): 111 000 (N)

Basic dynamic load rating C_{100}

(Y axis linear guide LA35): 49 000 (N)

Basic dynamic load rating C_{100}

(Z axis linear guide LA65): 206 000 (N)

Load coefficient f_w : 1.5

Hardness coefficient f_H : 1

Rating fatigue life $L = 100 \times \left(\frac{f_H \cdot C_{100}}{f_w \cdot F_m} \right)^3$

From this,

In case of X axis $L_x = 66\ 617$ (km)

In case of Y axis $L_y = 140\ 012$ (km)

In case of Z axis $L_z = 107\ 722$ (km)

In case of roller linear guides, refer to "A-3-2.2 6."

Calculate using Pattern 4 in Table 2.2.

Load conditions	Deformation direction	Deformation of each axis (μm)			Total deformation (μm)
		X axis	Y axis	Z axis	
Table weight alone	δx	-0.2	-0.1	-3.1	-3.4
	δy	-4.6	-0.3	-4.2	-9.1
	δz	-4.3	-0.1	-4.9	-9.3
Milling process	δx	-9.9	-1.3	-6.7	-17.9
	δy	-6.4	-1.7	-5.2	-13.3
	δz	-6.1	-0.4	-7.7	-14.2
Drilling process	δx	-0.9	-0.3	-4.6	-5.8
	δy	1.4	0.8	2.8	5.0
	δz	5.5	1.2	7.6	14.3

Therefore, deformation at processing points at time of milling is:

$\delta x = -17.9 - (-3.4) = -14.5$ (μm)

$\delta y = -13.3 - (-9.1) = -4.2$ (μm)

$\delta z = -14.2 - (-9.3) = -4.9$ (μm)

Deformation at processing points at time of drilling is:

$\delta x = -5.8 - (-3.4) = -2.4$ (μm)

Calculation of rating life" (page A25).

Examination of static loads based on "A-3-2.2 7"

Basic static load rating C_0

(X axis linear guide LA55): 215 000 (N)

Basic static load rating C_0

(Y axis linear guide LA35): 98 000 (N)

Basic static load rating C_0

(Z axis linear guide LA65): 420 000 (N)

Examine a case of high-load milling process with large load.

X axis $f_s = \frac{C_0}{P_0} = \frac{C_0}{(F_r + F_s)} = \frac{215\ 000}{(6\ 539 + 997)} = 28.5$

Similarly,

Y axis $f_s = 61.5$

Z axis $f_s = 42.0$

Therefore, there is no problem.

(4) Calculation of deformation

Calculate deformation at the processing points.

(The stroke position is the stroke end positions on Y axis and X axis.)

Rigidity of X axis linear guide LA55Z3: 1 400 (N/μm)

Rigidity of Y axis linear guide LA35Z3: 825 (N/μm)

Rigidity of Z axis linear guide LA65Z3: 1 730 (N/μm)

$\delta y = 5.0 - (-9.1) = 14.1$ (μm)

$\delta z = 14.3 - (-9.3) = 23.6$ (μm)

If a rating life of this long period is not required, select a smaller linear guide model, and calculate the life again.

To reduce deformation at the processing point, select a linear guide model with higher rigidity, and then calculate the life again.

A-3-12 Reference

The articles in "Motion & Control (NSK Technical Journals)" which refer to NSK linear guides are listed in the table below for user convenience.

"Motion & Control" is compiled to introduce NSK products and its technologies.

For inquiries and orders of "Motion & Controls," please contact your local NSK sales offices, or Representatives.

Table 12.1 Motion & Control (NSK Technical Journal): Articles relating to linear guides (1997 –)

Issue No.	Date of Publication	Articles related to linear guides
No.5	Dec. 1998	Development of the NSK K1 Seal for Linear Guides
No.8	May. 2000	NSK Linear Guides for High-Temperature Environments
No.9	Oct. 2000	Recent Developments in Highly Precise NSK Linear Guides
No.9	Oct. 2000	High-Performance Seals for NSK Linear Guides
No.11	Oct. 2001	Development of the NSK S1 Series™ Ball Screws and Linear Guides High Load Capacity Mini LH Series of NSK Linear Guides
No.12	Apr. 2002	NSK Linear Guides & Ball Screws Equipped with NSK K1™ Lubrication Unit
No.12	Apr. 2002	NSK S1 Series™ NSK Linear Guides and Ball Screws
No.13	Oct. 2002	Translide™ -New Rolling Element Linear Motion Bearing-
No.14	May. 2003	New Generation of NSK Linear Guides Miniature PU Series
No.15	Dec. 2003	Ultra-Precision NSK Linear Guides for Machine Tools-the HA Series
No.16	Aug. 2004	Numerical analysis Technology & NSK Linear Guides for Machine Tools
No.16	Aug. 2004	NSK RA Series Roller Guide
No.18	Aug. 2005	New Generation of NSK linear Guides Miniature PU Series/PE Series
No.20	Aug. 2007	V1 Series of Highly Dust-Resistant NSK Linear Guides
No.21	Dec. 2009	Technological Trends of NSK Linear Guides for Industrial Machines Highly Accurate HS Series of Ultra-Precision NSK Linear Guides Linear Guides for Food Machine and Medical Devices
No.22	Mar. 2011	Technological Trends of NSK Linear Guides for Industrial Machines High-Accuracy HS Series of Ultra-Precision NSK Linear Guides NSK Linear Guides for Food Processing Equipment and Medical Devices
No.23	Jun. 2013	Technological Trends in Linear Motion Rolling Guides for Machine Tools
No.24	Dec. 2014	Slight-Preload Type RA Series Roller Guides of NSK Linear Guides
No.25	Sep. 2015	Precision-Grade, Medium-Preload, Random-Matching NSK linear Guides Random-Matching, Miniature PU and PE Series of NSK Linear Guides
No.26	Apr. 2016	NSK Roller Guides Equipped with V1 Seals Random-matching, High-Precision-Grade RA Series Roller Guides
No.27	Nov. 2016	NH Series and NS Series NSK Linear Guides: More than Twice the Life of Conventional NSK Linear Guides

A-4 NSK Linear Guide™

1. Structure of NSK Linear Guides

By avoiding structural complexity, and by reducing the number of components, we not only enhanced the precision of linear guides, but also are able to keep costs low. We have added NSK's patented unique structural feature to the original invention (Fig. 1). This contributes to higher precision and lower prices.

NSK linear guides consist of a rail and a slide (Fig. 2). The balls or rollers roll on the race way surface, and are scooped up by the end caps attached to both ends of the slide. Then, the balls or rollers go through a passage made in the slide and circulate back to the other end.

2. Characteristics of NSK Linear Guides

The use of a unique offset Gothic arch groove (Fig. 3) allows the ball type of NSK linear guides to satisfy groove designs required for specific purposes.

This unique groove design facilitates precise measurement of the ball groove, thus enabling the stable and highly accurate production of the slides and the rails for random matching. (Fig. 4)

On top of that, we have developed and marketed the NSK Roller Guides, representing the culmination of NSK's analysis technology and tribology.

Such technologies ensure the features of NSK linear guides outlined below.

(1) High precision and quality

- High precision and quality come from our superb production and measuring technologies, strengthened by extensive experience in antifriction rotary bearings and ball screw production. Our quality assurance extends to the smallest components.

(2) High reliability and durability

- Logical simplicity in shape, along with stable processing, maintains high precision and reliability.
- Super-clean materials, our advanced heat treatment and processing technologies increase product durability.

(3) Abundant in type for any purpose

- Various series are available, and their slide models and size categories are standardized to satisfy any requirement. Our technology, polished by abundant experience in the use of special materials and surface treatments, meets the customer's most demanding expectations.

(4) Development of random-matching parts for short delivery time

- The adoption of the Gothic arch groove which makes measuring easy, and a new reliable quality control method has made random-matching of the rails and the ball or roller slides possible. The parts are stocked as standard products, thereby reducing delivery time.

(5) Patented static load carrying capacity (shock-resistance)

- When a super-high load (impact) is applied, our Gothic arch groove spreads the load to surfaces which usually do not come into contact in the ball type NSK linear guides. This increases impact load resistance (Fig. 5).

(6) Lineup of extremely high-load capacity series

- The LA series provides a top class high-load capacity for the ball linear guides through a unique load carrying configuration with three ball recirculation circuits on the one side.

By installing rollers that are the largest possible diameter and length, the NSK roller linear guides have realized the world's highest load capacity, far superior to the roller linear guides of other companies.

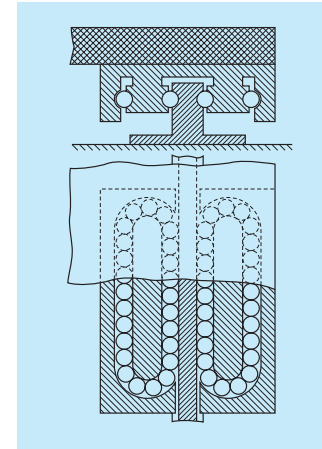

Fig. 1 • French Patent in 1932.
• Inventor: Gretsh (German)

NSK added its patented technology to the invention in Fig. 1, and improved the linear guide structure and realized low cost design.

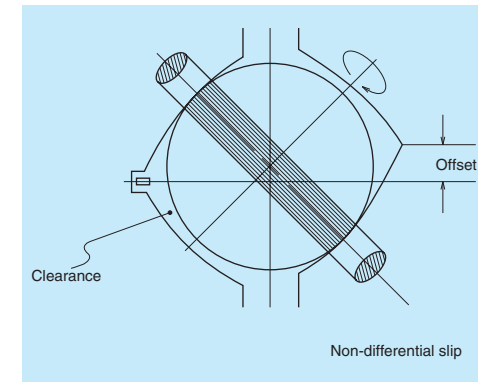

Fig. 3 Two contact point at offset Gothic arch groove

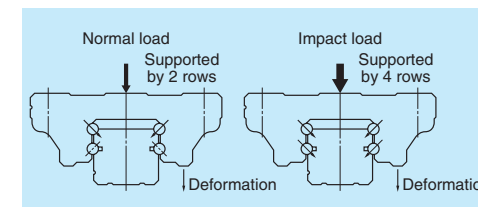

Fig. 5 Shock-resistance

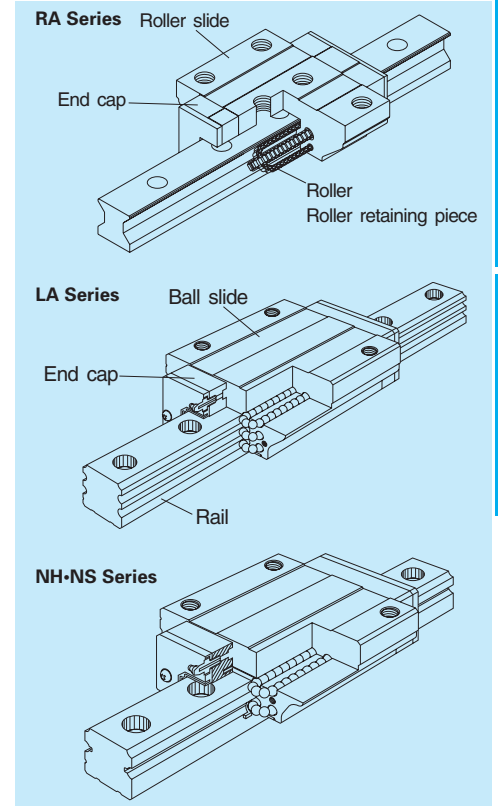

Fig. 2 Structure of NSK linear guides

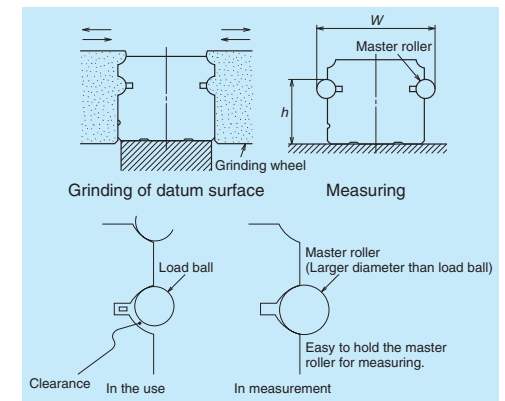

Fig. 4 Processing and measuring grooves

Measuring grooves accuracy is easy. You can obtain highly accurate results for all types of NSK series. This is why you can purchase rails and slides separately for random matching.

3. Types and Characteristics of NSK Linear Guides

Category	Series	Slide shape	Shape/installation method	Load direction/capacity	Rolling element contact structure	
High vertical load carrying capacity type	Self-aligning type	NH	AN BN			
			AL BL			
			EM GM			
			High-load type	AN, AL		EM

Note: For customers who have used the former LH or SH series, NH series is recommended as a substitute. Please confirm the correlation between NH series and former ones on the comparative table at A319.

Characteristics	Applications	Page
<p>The NH series is applicable to a wide range of uses from general industrial use to high-accuracy application.</p> <p>Random-matching of rails and ball slides is available as a standard.</p> <ul style="list-style-type: none"> ● The contact angle between the ball and ball groove is set at 50 degrees. This design increases the load carrying capacity against the vertical directions, which is the main load acting direction in most operations. ● The DF contact structure greatly absorbs the installation error in the perpendicular direction to the rail. ● Balls make contact at two points thanks to the offset Gothic arch groove. This keeps friction to a minimum. ● High resistance against shock load due to the unique load-carrying structure. ● Gothic arch groove renders measuring of ball grooves accurate and easy. ● Standardized random-matching type allows separate purchase of rails and ball slides. ● Stainless steel standard type is also available for small sizes (NH15 to NH30). 	<ul style="list-style-type: none"> • Cartesian type robots • Robots that remove plastic molds from injection machine • Material handling equipment • Food processing machines • Packaging/packing machines • Printing machines • Woodworking machines • Paper manufacturing machines • Measuring equipment • Inspecting equipment • Semiconductor manufacturing equipment • LCD manufacturing equipment • Medical equipment • Electric discharge machines • Laser cutting machines • Press machines • Tool grinders • Flat surface grinders • NC lathes • Machining centers • Automatic tool changers 	A113
Super-high-load type		
BN, BL		
GM		

Category	Series	Slide shape	Shape/installation method	Load direction/capacity	Rolling element contact structure	
High vertical load carrying capacity type	Self-aligning type	VH	AN BN			
			AL BL			
			EM GM			
			High-load type AN, AL			

Characteristics	Applications	Page	
<p>The VH series delivers outstanding dust-proof functionality and thus ensures long operating life under contaminated environments. Random-matching of rails and ball slides is available as a standard.</p> <ul style="list-style-type: none"> ● The contact angle between the ball and the raceway is set at 50 degrees. This design increases the load carrying capacity against vertical directions, which is the main load acting direction in most operations. ● The DF contact structure greatly absorbs the installation error in the perpendicular direction to the rail. ● Thanks to the offset Gothic arch groove, balls make contacts at two points. This keeps friction to a minimum. ● High resistance against shock load due to the unique load carrying structure. ● Gothic arch groove renders measuring groove accurate and easy. ● Standardized random-matching type allows separate purchase of rails and ball slides. ● Penetration of fine contaminants is less than 1/10 of the existing products. ● Operating life under contaminated environments is more than 5 times longer. 	<ul style="list-style-type: none"> • Automotive manufacturing equipment • Press machines • Machine tools loader/un-loader • Tire molding machines • Woodworking machines • Automatic doors 	A133	
<p>Super-high-load type</p> <p>BN, BL</p>		GM	

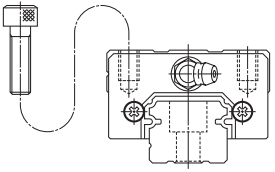
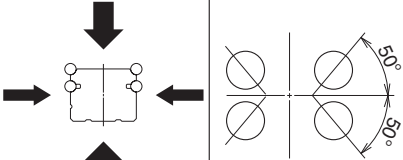
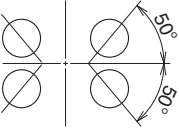
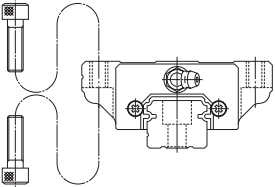
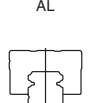
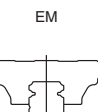
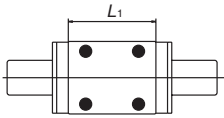
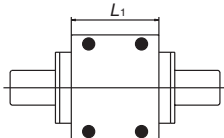
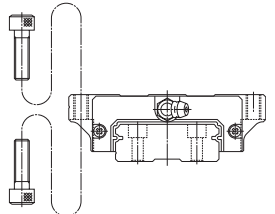
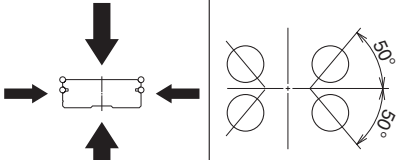
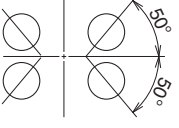
Category	Series	Slide shape	Shape/installation method	Load direction/capacity	Rolling element contact structure
High vertical load carrying capacity type	Self-aligning type	NS	<p>CL AL</p> 		
			<p>JM EM</p> 		
			<p>High-load type</p> <p>AL</p>  <p>EM</p> 	 	
High moment capacity type	LW	EL			

Note: For customers who have used the former LS or SS series, NS series is recommended as a substitute. Please confirm the correlation between NS series and former ones on the comparative table at A319.

Characteristics	Applications	Page
<p>The NS series is low in height, and is applicable to a wide range of uses from general industrial use to high-accuracy application. Random-matching of rails and ball slides is available as a standard.</p> <ul style="list-style-type: none"> ● Compact and low profile. ● The contact angle between the ball and the groove is set at 50 degrees. This design increases the load carrying capacity against vertical directions, which is the main load direction prevalent in most operations. ● The DF contact structure greatly absorbs the installation error in the perpendicular direction of the rail. ● Thanks to the offset Gothic arch groove, balls make contacts at two points. This keeps friction to a minimum. ● High resistance against shock load due to the unique load carrying structure. ● Gothic arch groove renders measuring groove accurate and easy. ● Standardized random-matching type allows separate purchase of rails and ball slides. ● Stainless steel type is also available. 	<ul style="list-style-type: none"> • Cartesian type robots • Robots that remove plastic molds from injection machine • Material handling equipment • Food processing machines • Packaging/packing machines • Printing machines • Woodworking machines • Paper manufacturing machines • Measuring equipment • Inspection equipment • Semiconductor manufacturing equipment • LCD manufacturing equipment • Medical equipment • Electric discharge machines • Laser cutting machines • Press machines 	A153
<p>High-moment rigidity and low profile products are most suited for a single rail linear guideway system. Random-matching of rails and ball slides is available as a standard.</p> <ul style="list-style-type: none"> ● The wide rail contributes to a high rolling moment carrying capacity and to great moment rigidity of a single rail linear guideway system. ● Balls contact at two points in the Gothic arch groove, thus keeping friction to a minimum. ● High resistance against shock load ● Standardized random-matching type allows separate purchase of rails and ball slides. 	<ul style="list-style-type: none"> • Semiconductor manufacturing equipment • LCD manufacturing equipment • Conveyor systems • Medical equipment • Microscope XY stages 	A171

Category	Series	Slide shape	Shape/installation method	Load direction/capacity	Rolling element contact structure
Miniature type	Standard type	PU			
		LU			
	High moment capacity type	PE			
		LE			
			<p>Standard type</p> <p>PU, LU AL, TL, AR, TR</p>	<p>High-load type</p> <p>BL, UL, UR</p>	

Characteristics	Applications	Page			
<p>Low inertia and low dust generation miniature series.</p> <ul style="list-style-type: none"> ● Low dust generation and highly smooth operation ● Super-compact size ● Stainless steel is the standard material. ● A ball retainer is a standard equipment. ● Standardized random-matching type allows separate purchase of rails and ball slides. 	<ul style="list-style-type: none"> • Semiconductor manufacturing equipment • LCD manufacturing equipment • Medical equipment • Optical stages • Microscope XY stages • Conveying system of optical fibers • Miniature robots • Computer peripherals • Pneumatic equipment 	A187			
<p>Miniature series</p> <ul style="list-style-type: none"> ● Extremely compact size ● Stainless steel is the standard material. ● A ball retainer is a standard equipment. ● Standardized random-matching type allows separate purchase of rails and ball slides. 		A197			
<p>Wide rail miniature with low inertia and low dust generation.</p> <ul style="list-style-type: none"> ● Low dust generation and highly smooth operation ● Super-compact size ● Stainless steel is the standard material. ● A ball retainer is a standard equipment. ● Standardized random-matching type allows separate purchase of rails and ball slides. 	<ul style="list-style-type: none"> • Semiconductor manufacturing equipment • LCD manufacturing equipment • Medical equipment • Optical stages • Microscope XY stages • Conveying optical fibers • Miniature robots • Computer peripherals • Pneumatic equipment 	A209			
<p>Miniature wide series</p> <ul style="list-style-type: none"> ● Super-small size in wide rail type ● Stainless steel is the standard material. ● A ball retainer is a standard equipment. ● Standardized random-matching type allows separate purchase of rails and ball slides. 		A219			
			<p>Standard type</p> <p>AL, TL, AR, TR</p>	<p>High-load type</p> <p>BL, UL, BR, UR</p>	<p>Medium-load type</p> <p>CL, SL (LE only)</p>

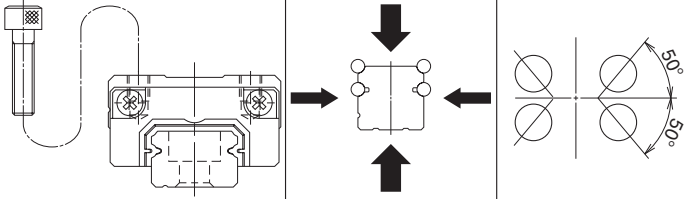
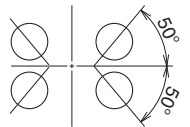
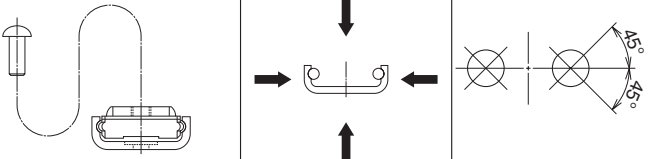
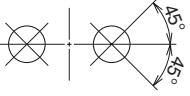
Category	Series	Slide shape	Shape/installation method	Load direction/capacity	Rolling element contact structure
Miniature type	Self-aligning type	LH	AN		
	Lightweight type	LL	PL		

Characteristics	Applications	Page
<p>High vertical load carrying capacity and self-aligning type miniature series</p> <ul style="list-style-type: none"> ● The contact angle between the ball and ball groove is set at 50 degrees. This design increases the load carrying capacity against the vertical directions, which is the main load acting direction in most operations. ● The DF contact structure greatly absorbs the installation error in the perpendicular direction to the rail. ● Balls make contact at two points thanks to the offset Gothic arch groove. This keeps friction to a minimum. ● High resistance against shock load due to the unique load-carrying structure. ● Gothic arch groove renders measuring of ball grooves accurate and easy. ● A ball retainer is a standard equipment. (LH10~12) ● Stainless steel type is standard. 	<ul style="list-style-type: none"> • Semiconductor manufacturing equipment • LCD manufacturing equipment • Medical equipment • Optical stages • Microscope XY stages • Miniature robots • Computer peripherals • Pneumatic equipment 	A233
<p>The LL series is a compact and lightweight miniature linear guide for press molding.</p> <ul style="list-style-type: none"> ● Rails and ball slides are made of thin steel plate, and thus making them very light. ● Stainless steel is the standard material. 	<ul style="list-style-type: none"> • Platter pen heads • Robot hands • Pneumatic equipment 	A243

Category	Series	Slide shape	Shape/installation method	Load direction/capacity	Rolling element contact structure
Four-way equal load carrying capacity type	Super-rigid type	RA	AN BN		
			AL BL		
			EM GM		
Four-way equal load carrying capacity type	Super-rigid type	LA	AN BN		
			AL BL		
			EL GL		
			FL HL		

Characteristics	Applications	Page
<p>The RA series roller guides have realized the world highest load capacity. Super-high rigidity and smooth motion contribute to higher performance of machine tools.</p> <ul style="list-style-type: none"> ● Unique and optimum design of rollers and other component facilitate the high-load capacity and high rigidity. ● High-performance seals, a standard feature in the roller guides, maintain the initial performance for a prolonged time. ● The installation of retaining piece achieves smooth motion. ● Standardized random-matching type allows separate purchase of rails and roller slides. 	<ul style="list-style-type: none"> • Machining centers • NC lathes • Heavy cutting machine tools • Gear cutters • Electric discharge machines • Press machines • Various types of grinders 	A249
<p>High-load type AN, AL</p> <p>EM</p> <p>Super-high-load type BN, BL</p> <p>GM</p>		
<p>As well as providing a low friction operation, the LA series provides a top class high-load capacity for the ball linear guides. The series is most suited for machine tools.</p> <ul style="list-style-type: none"> ● The contact angle between the ball and the raceway is set at 45 degrees. This makes load carrying capacity and rigidity equal in vertical and lateral directions. ● Six-row ball grooves support the load from vertical and lateral directions, enhancing rigidity and increasing load carrying capacity. ● Appropriate friction ● Best suited for machine tools. 	<ul style="list-style-type: none"> • Machining centers • NC lathes • Heavy cutting machine tools • Gear cutters • Electric discharge machines • Press machines • Various types of grinders 	A271
<p>High-load type AN, AL</p> <p>EL, FL</p> <p>Super-high-load type BN, BL</p> <p>GL, HL</p>		

Category	Series	Slide shape	Shape/installation method	Load direction/capacity	Rolling element contact structure	
Four-way equal load carrying capacity type	Super rigidity, high-precision type	HA	AN		 	
			AL			
			EM			
				AN, AL		
High vertical load carrying capacity type	Self-aligning, super-precision type	HS	AL		 	
			EM			
				AL		
				EM		

Characteristics	Applications	Page
<p>The HA Series ball guide with high-precision and high-load carrying capacity, featuring high-motion accuracy equivalent to hydrostatic linear bearings.</p> <ul style="list-style-type: none"> ● Ball passage vibration has been reduced to one-third of conventional models by ultra-long ball slides and specification of new design. ● The contact angle between the ball and the raceway is set at 45 degrees. This makes load carrying capacity and rigidity equal in vertical and lateral directions. ● High motion accuracy is realized by the feature of super-finished ball groove (optional). ● End seals, bottom seals, and inner seals of high dust-proof specification are the standard equipment. ● Best suited for high-grade machine tools. 	<ul style="list-style-type: none"> • Die molding machines • High precision processing machine • Heavy cutting machine tools • Gear cutters • Press machines • Various types of NC grinders 	A291
<p>The HS Series ball guide with high-precision featuring high-motion accuracy equivalent to hydrostatic linear bearings.</p> <ul style="list-style-type: none"> ● Ball passage vibration has been reduced to one-third of conventional models by ultra-long ball slides and specification of new design. ● The contact angle between the ball and the raceway is set at 50 degrees. The load carrying capacity against vertical directions, which is the main load acting direction in most operations, increases by this design. ● The DF contact structure greatly absorbs the installation error in the perpendicular direction of rail. ● Thanks to the offset Gothic arch groove, balls make contacts at two points, thus keeping friction low. 	<ul style="list-style-type: none"> • High precision processing machines • Electric discharge machines • Various types of NC grinders • LCD manufacturing equipment 	A305

4. Guide to Technical Services

(1) CAD drawing data

NSK offers CAD data for linear guides. Please download it from the website of NSK.

NSK website
http://www.nsk.com

- Data in drawings are filed in the actual size (some parts are simplified). You can use these data without processing.
- Drawings are three-views projection.
- Dimension lines are omitted to render the data as standard drawing for database.

Data offered by CAD

NSK linear guides

NH Series
VH Series
NS Series
LW Series
PU Series
LU Series
PE Series
LE Series
Miniature LH Series
RA Series
LA Series
HA Series
HS Series

(2) Telephone consultation with NSK engineers

This catalog contains technical explanation for each section. However, some descriptions and explanations may be insufficient due to page limitation, etc. To amend this shortcoming, NSK offers telephone assistance. NSK engineers are pleased to help you. Our local offices are listed in the last part of this catalog. Call local NSK office or Representative in your area.

5. Linear Guides: Handling Precautions

NSK linear guides are high quality and are easy to use. NSK places importance on safety in design. For maximum safety, please follow precautions as outlined below.

(1) Lubrication



Confirm lubrication.

- If your linear guide is rust prevention specification, thoroughly wipe the rust prevention oil and put lubricant inside of slide before using. For seal lubrication products, put lubricant on the rail.
- Do not mix greases of different brands.
- If your linear guide is rust prevention specifications, put lubricant inside of slide before using.

(2) Handling



Handle with care.



Do not disassemble.



Do not drop.



Do not give impact.

- Slides for random-matching are installed to the provisional rail when they leave the factory. Handle the slide with care during installation to the rail.
- Do not disassemble the linear guide unless absolutely necessary. Not only does it allow dust to enter, but it lessens precision.
- The slide may move by simply leaning the rail. Make sure that the slide does not disengage from the rail.
- Standard end cap is made of plastic. Beating it or hitting it against an object may cause damage.

(3) Precautions in use



Do not contaminate.



Do not hang upside down.

- Make every effort not to allow dust and foreign objects to enter.
- Please apply splash guard or bellows to the linear guide to prevent sticking resolvent or coolant when it contains corrosive material.
- The temperature of the place where linear guides are used should not exceed 80°C (excluding heat-resistant type linear guides). A higher temperature may damage the plastic end cap.
- If the user cuts the rail, thoroughly remove burrs and sharp edges on the cut surface.
- When hanging upside-down (e.g. the rail is installed upside-down on the ceiling in which the slide faces downward), should the end cap be damaged, causing the balls or rollers to fall out, the slide may be detached from the rail and fall. For such use, take measures including installing a safety device.

(4) Storage



Store in the correct position.

- Linear guide may bend if the rail is stored in inappropriate position. Place it on a suitable surface, and store it in a flat position.

6. Design Precautions

The following points must be heeded in examining the life.



In case of oscillating stroke

- If the balls or rollers do not rotate all the way, but only halfway, and if this minute stroke is repeated, lubricant disappears from the contact surface of balls or rollers and raceways. This generates "fretting," a premature wear. Fretting cannot be entirely prevented in such a case but it can be mitigated.
- We recommend anti-fretting grease for oscillating stroke operations. Even in a case using a standard grease, the life can be markedly prolonged by adding a normal stroke travel (about the slide length) once every several thousand cycles.



When applying pitching or yawing moment

- Load applied to the ball or roller rows inside the slide is inconsistent if pitching or yawing moment load is applied. Loads are heavy on the balls or rollers on each end of the row.
- In such a case, a heavy load lubricant grease or oil is recommended. Another countermeasure is using one size larger model of linear guide to reduce the load per ball or roller.
- Moment load is insignificant for 2-rail, 4-slide combination which is commonly used.



When an extraordinary large load is applied during stroke

- If an extraordinary large load is applied at certain position of the stroke, calculate not only the life based on the mean effective load, but also the life based on the load in this range.
- When an extraordinary heavy load is applied and thus the application of high tensile stress to fixing bolts of the rails and slides is foreseen, the strength of the bolts should be considered.



When calculated life is extraordinarily short (Less than 3 000 km in calculated life.)

- In such a case, the contact pressure to the balls or rollers and the rolling contact surface is extraordinarily high.
- When a linear guide is operated under such state continually, the life is significantly affected by the loss of lubrication and the presence of dust, and thus the actual life becomes shorter than calculated.
- It is necessary to reconsider the number of slides, the arrangement of slides, and the type of model in order to reduce the load to the slide.
- It is necessary to consider preload for calculation of rating life when selecting Z3 (medium preload) or Z4 (heavy preload) as a preload. For the calculation of full dynamic equivalent loads that consider preload, see "A-3-3 6" on page A31. Please consult NSK for details.



Application at high speed

- The standard maximum allowable speed of a linear guide under normal conditions is 100 m/min. However, the maximum allowable speed can be affected by accuracy of installation, temperature, external loading etc.
- The end cap with high speed specification must be used when operating speed exceeds the permissible speed. In such a case, please consult NSK.

A-5 Technical Description and Dimension Table for NSK Linear Guides

1. NH Series	A113
2. VH Series	A133
3. NS Series	A153
4. LW Series	A171

A-5-1 General Industrial Use

A-5-1.1 NH Series

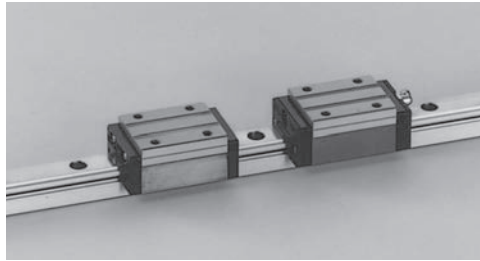

1. Features

(1) Improve rating life dramatically

Based on the LH series characterized by reliability and performance, a significant increase in durability has been attained. New ball groove geometry is introduced, which has been developed by utilizing NSK's state-of-the-art tribological and analytical technologies. Due to the optimized distribution of contact surface pressures, the rating life has dramatically increased.

As compared with the LH Series, the load rating capacity of the NH series has increased to 1.3 times, while the life span has increased to twice^{*1}. These features enable you to design a machine with a longer life and downsize the machine. Thus, your design capability is greatly enhanced.

*1: Representative values of series.

(2) Ball circulation path with excellent high-speed property

By reexamining the design practice for the ball circulation path, we have attained smooth ball circulation and reduced noise level. So, NH series is suited for high-speed applications compared with the LH Series.

(3) All mounting dimensions are the same as those for the LH and SH Series

Regarding the mounting dimensions (mounting parts' dimensions), such as the mounting height, mounting width, mounting hole diameter/pitch of the linear guide, etc., the mounting dimensions of the NH Series remain the same as those of the conventional LH series and SH series. So, the new NH Series linear guides can be used without making any design changes.

(4) High self-aligning capability (rolling direction)

Same as the DF combination in angular contact

bearings, self-aligning capability is high because the cross point of the contact lines of balls and grooves comes inside, and thus reducing moment rigidity.

This increases the capacity to absorb errors in installation.

(5) High load carrying capacity to vertical direction

The contact angle is set at 50 degrees, and thus increasing load carrying capacity as well as rigidity in vertical direction.

(6) High resistance against impact load

The bottom ball groove is formed in Gothic arch and the center of the top and bottom grooves are offset as shown in Fig. 2. The vertical load is generally carried by the top ball rows, where balls are contacting at two points. Because of this design, the bottom ball rows will carry load when a large impact load is applied vertically as shown in Fig. 3. This assures high resistance to the impact load.

(7) High accuracy

As showing in Fig. 4, fixing the master rollers to the ball grooves is easy thanks to the Gothic arch groove. This makes easy and accurate measuring of ball grooves.

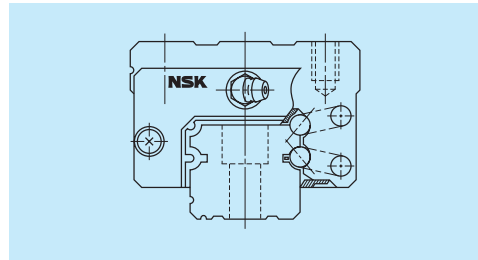

Fig. 1 NH Series

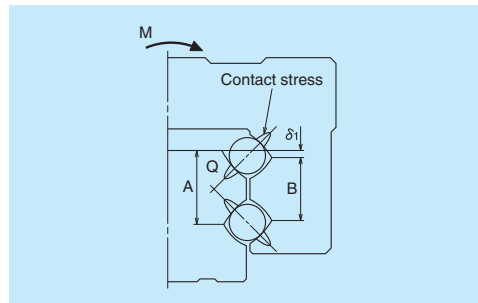

Fig. 2 Enlarged illustration of the offset Gothic arch groove

(8) Easy to handle, and designed with safety in mind.

Balls are retained in the retainer, therefore they do not fall out when the ball slide is withdrawn from the rail.

(9) Abundant models and sizes

Each size of NH Series has various models of ball slides, rendering the linear guide available

for numerous uses.

(10) Fast delivery

Lineup of random-matching rails and ball slides supports and facilitates fast delivery. High precision grade and medium preload types are also available in random matching. (Special high-carbon steel products)

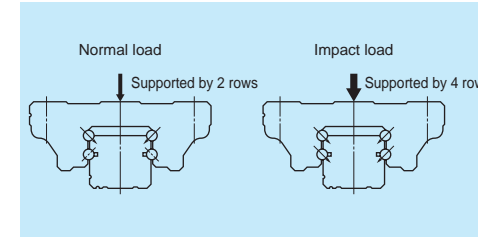

Fig. 3 When load is applied

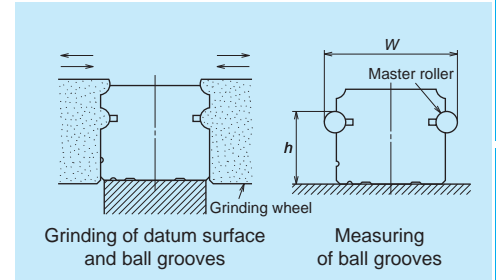

Fig. 4 Rail grinding and measuring

2. Ball slide shape

Ball slide Model	Shape/installation method	Type (Upper row, Rating: Lower row, Ball slide length)	
		High-load type	Super-high-load type
		Standard	Long
AN BN		AN 	BN
AL BL		AL 	BL
EM GM		EM 	GM

Note: For customers who have used the former LH or SH series, NH series is recommended as a substitute. Please confirm the correlation between NH series and former ones on the comparative table at A319.

3. Accuracy and preload

(1) Running parallelism of ball slide

Table 1

Unit: μm

Rail length (mm) over or less	Preloaded assembly (not random matching)					Random-matching type	
	Ultra precision P3	Super precision P4	High precision P5	Precision grade P6	Normal grade PN	High precision PH	Normal grade PC
– 50	2	2	2	4.5	6	2	6
50 – 80	2	2	3	5	6	3	6
80 – 125	2	2	3.5	5.5	6.5	3.5	6.5
125 – 200	2	2	4	6	7	4	7
200 – 250	2	2.5	5	7	8	5	8
250 – 315	2	2.5	5	8	9	5	9
315 – 400	2	3	6	9	11	6	11
400 – 500	2	3	6	10	12	6	12
500 – 630	2	3.5	7	12	14	7	14
630 – 800	2	4.5	8	14	16	8	16
800 – 1 000	2.5	5	9	16	18	9	18
1 000 – 1 250	3	6	10	17	20	10	20
1 250 – 1 600	4	7	11	19	23	11	23
1 600 – 2 000	4.5	8	13	21	26	13	26
2 000 – 2 500	5	10	15	22	29	15	29
2 500 – 3 150	6	11	17	25	32	17	32
3 150 – 4 000	9	16	23	30	34	23	34

(2) Accuracy standard

The preloaded assembly has five accuracy grades; Ultra precision P3, Super precision P4, High precision P5, Precision P6 and Normal PN grades, while the random-matching type has High precision PH and Normal PC grade.

• Tolerance of preloaded assembly

Table 2

Unit: μm

Characteristics	Ultra precision P3	Super precision P4	High precision P5	Precision grade P6	Normal grade PN
Mounting height H Variation of H (All ball slides on a set of rails)	± 10 3	± 10 5	± 20 7	± 40 15	± 80 25
Mounting width W_2 or W_3 Variation of W_2 or W_3 (All ball slides on reference rail)	± 15 3	± 15 7	± 25 10	± 50 20	± 100 30
Running parallelism of surface C to surface A Running parallelism of surface D to surface B	Shown in Table 1, Fig. 5, and Fig. 6				

• Tolerance of random-matching type

Table 3

Unit: μm

Accuracy grade	High precision grade PH		Normal grade PC		
Characteristics	Model No.	NH15, 20, 25, 30, 35	NH45, 55, 65	NH15, 20, 25, 30, 35	NH45, 55, 65
Mounting height H		± 20	± 30	± 20	± 30
Variation of mounting height H		15① 30②	20① 35②	15① 30②	20① 35②
Mounting width W_2 or W_3		± 30	± 35	± 30	± 35
Variation of mounting width W_2 or W_3		20	20	25	30
Running parallelism of surface C to surface A Running parallelism of surface D to surface B	See Table 1, Fig. 5 and Fig. 6				

Note: ① Variation on the same rail ② Variation on multiple rails

(3) Combinations of accuracy and preload

Table 4

	Accuracy grade							
	Ultra precision	Super precision	High precision	Precision grade	Normal grade	High precision	Normal grade	
Without NSK K1 lubrication unit	P3	P4	P5	P6	PN	PH	PC	
With NSK K1 lubrication unit	K3	K4	K5	K6	KN	KH	KC	
With NSK K1 for food and medical equipment	F3	F4	F5	F6	FN	FH	FC	
Preload	Fine clearance Z0	○	○	○	○	○	—	—
	Slight preload Z1	○	○	○	○	○	—	—
	Medium preload Z3	○	○	○	○	—	—	—
	Random-matching type with fine clearance ZT	—	—	—	—	—	—	○
	Random-matching type with slight preload ZZ	—	—	—	—	—	○	○
	Random-matching type with medium preload ZH	—	—	—	—	—	○	○

(4) Assembled accuracy

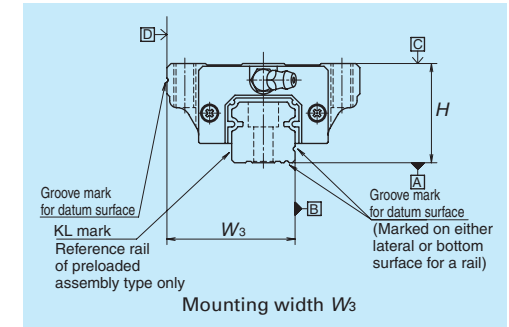
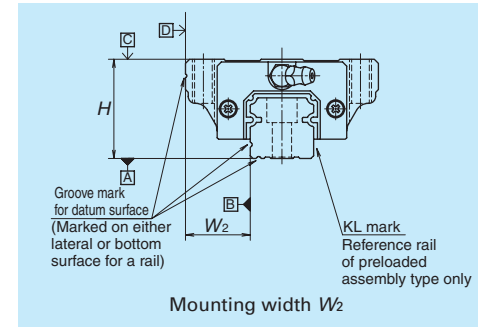

Fig. 5 Special high carbon steel

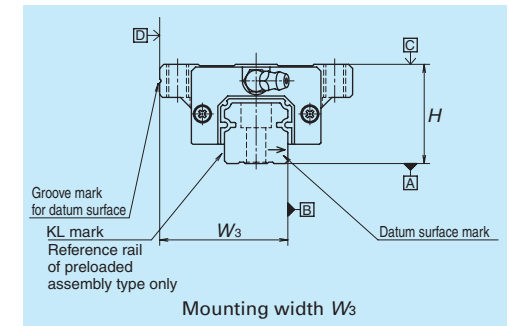
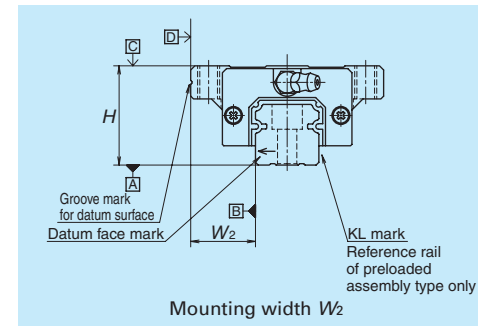

Fig. 6 Stainless steel

(5) Preload and rigidity

We offer six levels of preload: Slight preload Z1, Medium preload Z3 and Fine clearance Z0, along with random-matching type of Medium preload ZH, Slight preload ZZ and Fine clearance ZT.

• **Preload and rigidity of preloaded assembly**

Table 5

Model No.	Preload (N)		Rigidity (N/μm)				
			Vertical direction		Lateral direction		
	Slight preload Z1	Medium preload Z3	Slight preload Z1	Medium preload Z3	Slight preload Z1	Medium preload Z3	
High-load type	NH15 AN, EM	78	490	137	226	98	186
	NH20 AN, EM	147	835	186	335	137	245
	NH25 AL, AN, EM	196	1 270	206	380	147	284
	NH30 AL, AN	245	1 570	216	400	157	294
	NH30 EM	294	1 770	265	480	186	355
	NH35 AL, AN, EM	390	2 350	305	560	216	390
Super-high-load type	NH45 AL, AN, EM	635	3 900	400	745	284	540
	NH55 AL, AN, EM	980	5 900	490	910	345	645
	NH65 AN, EM	1 470	8 900	580	1 070	400	755
	NH15 BN, GM	98	685	196	345	137	284
	NH20 BN, GM	196	1 080	265	480	196	355
	NH25 BL, BN, GM	245	1 570	294	560	216	400
	NH30 BL, BN, GM	390	2 260	360	665	265	480
	NH35 BL, BN, GM	490	2 940	430	795	305	570
	NH45 BL, BN, GM	785	4 800	520	960	370	695
	NH55 BL, BN, GM	1 180	7 050	635	1 170	440	835
NH65 BN, GM	1 860	11 300	805	1 480	550	1 040	

Note: Clearance for Fine clearance Z0 is 0 to 3μm. Therefore, preload is zero. However, Z0 of PN grade is 0 to 15μm.

• **Clearance and preload of random-matching type**

Table 6

Model No.	Fine clearance ZT	Slight preload ZZ	Medium preload ZH
NH15	-4 — 15	-4 — 0	-7 — -3
NH20	-5 — 15	-5 — 0	-8 — -3
NH25		-5 — 0	-9 — -4
NH30		-7 — 0	-12 — -5
NH35		-7 — 0	-12 — -5
NH45		-7 — 0	-14 — -7
NH55		-9 — 0	-18 — -9
NH65	-9 — 0	-19 — -10	

Note: Minus sign denotes that a value is an amount of preload (elastic deformation of balls).

4. Maximum rail length

Table 7 shows the limitations of rail length (maximum length). However, the limitations vary by accuracy grades.

Table 7 Length limitations of rails

Series	Material	Size	Unit: mm							
			15	20	25	30	35	45	55	65
NH	Special high carbon steel		2 980	3 960	3 960	4 000	4 000	3 990	3 960	3 900
	Stainless steel		1 800	3 500	3 500	3 500				

Note: Rails can be butted if user requirement exceeds the rail length shown in the table. Please consult NSK.

5. Installation

(1) Permissible values of mounting error

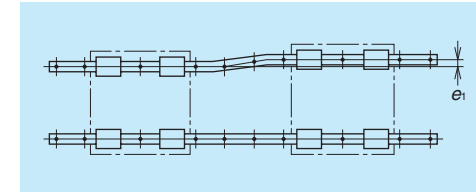

Fig. 7

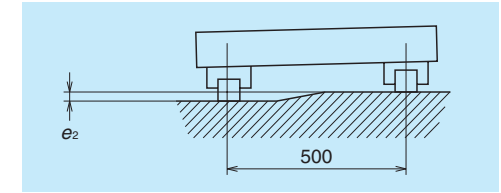

Fig. 8

Table 8

Value	Preload	Model No.							
		NH15	NH20	NH25	NH30	NH35	NH45	NH55	NH65
Permissible values of parallelism in two rails e ₁	Z0, ZT	22	30	40	45	55	65	80	110
	Z1, ZZ	18	20	25	30	35	45	55	70
	Z3, ZH	13	15	20	25	30	40	45	60
Permissible values of parallelism (height) in two rails e ₂	Z0, ZT	375μm/500mm							
	Z1, ZZ, Z3, ZH	330μm/500mm							

Unit: μm

Table 9

(2) Shoulder height of the mounting surface and corner radius r

Unit: mm

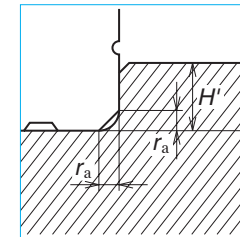

Fig. 9 Shoulder for the rail datum surface

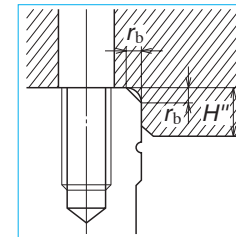

Fig. 10 Shoulder for the ball slide datum surface

Model No.	Corner radius (maximum)		Shoulder height	
	ra	rb	H'	H''
NH15	0.5	0.5	4	4
NH20	0.5	0.5	4.5	5
NH25	0.5	0.5	5	5
NH30	0.5	0.5	6	6
NH35	0.5	0.5	6	6
NH45	0.7	0.7	8	8
NH55	0.7	0.7	10	10
NH65	1	1	11	11

6. Maximum allowable speed

An indication of the standard maximum allowable speed aiming at 10,000km operation with NH series under normal conditions is shown in Table 10. However, the maximum allowable speed can be affected by accuracy of installation, operating temperature, external load, etc. If the operation is made exceeding the permissible distance and speed, please consult NSK.

Table 10 Maximum allowable speed

Series	Size	Unit: m/min						
		15	20	25	30	35	45	55
NH		300			200			150

7. Lubrication components

Refer to pages A38 and D13 for the lubrication of linear guides.

(1) Types of lubrication accessories

Fig. 11 and Table 11 show grease fittings and tube fittings.

We provide lubrication accessories with extended thread body length (L) for the addition of dust-proof accessories such as NSK K1 lubrication unit, double seal and protector.

We provide a suitable lubrication accessory for the special requirement on dust-proof accessories.

Consult NSK for a lubrication accessory with extended length of thread body for your convenience of replenishing lubricant.

When you require stainless lubrication accessories, please ask NSK.

(2) Mounting position of lubrication accessories

The standard position of grease fittings is the end face of ball slide. We mount them on a side of end cap for an option. (Fig. 12)

Please consult NSK for installation of grease or tube fittings to the ball slide body or side of end cap.

When using a piping unit with thread of M6 × 1, you require a connector to connect to a grease fitting mounting hole with M6 × 0.75. The connector is available from NSK.

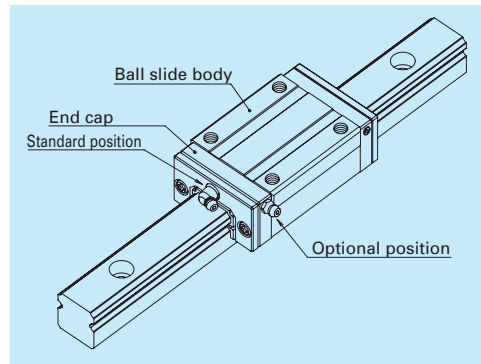

Fig. 12 Mounting position of lubrication accessories

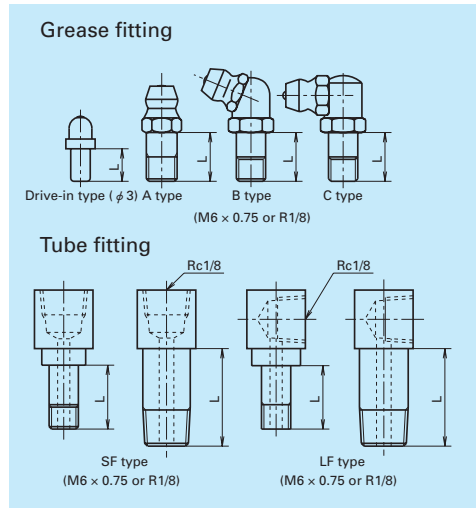

Fig. 11 Grease fitting and tube fitting

Model No.	Dust-proof specification	Dimension L		
		Grease fitting / Drive-in type	SF type	LF type
NH15	Standard	5	-	-
	With NSK K1	10	-	-
	Double seal	*	-	-
	Protector	*	-	-
NH20	Standard	5	-	-
	With NSK K1	12	-	-
	Double seal	10	-	-
	Protector	10	-	-
NH25	Standard	5	5	5
	With NSK K1	12	12	12
	Double seal	10	9	9
	Protector	10	9	9
NH30	Standard	5	6	6
	With NSK K1	14	12	13
	Double seal	12	10	11
	Protector	12	10	11
NH35	Standard	5	6	6
	With NSK K1	14	12	13
	Double seal	12	10	11
	Protector	12	10	11
NH45	Standard	8	13.5	17
	With NSK K1	18	20	21.5
	Double seal	14	16	17
	Protector	14	13.5	17
NH55	Standard	8	13.5	17
	With NSK K1	18	20	21.5
	Double seal	14	16	17
	Protector	14	13.5	17
NH65	Standard	8	13.5	17
	With NSK K1	20	22	25.5
	Double seal	16	18	19
	Protector	16	13.5	17

*) A connector is required for this model. Please contact NSK.

8. Dust-proof components

(1) Standard specification

The NH Series can be readily used as they have a dust protection means for normal conditions. As the standard equipment, the ball slides have an end seal on both ends, and bottom seals at the bottom.

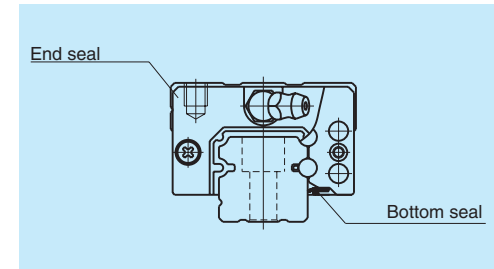
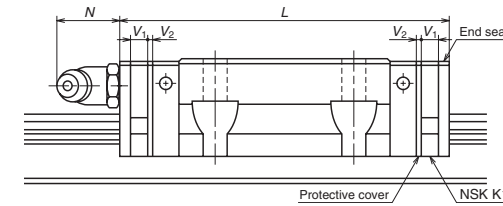

Fig. 13

Series	Size	15	20	25	30	35	45	55	65
NH		8	9	10	10	12	17	22	29

(2) NSK K1™ lubrication unit

Table 13 shows the dimension of linear guides equipped with the NSK K1 lubrication unit.



Model No.	Ball slide length	Ball slide model	Standard ball slide length	Ball slide length installed with two NSK K1 L	Per NSK K1 thickness V ₁	Protective cover thickness V ₂	Protruding area of the grease fitting N
NH15	Standard	AN, EM	55	65.6	4.5	0.8	(5)
	Long	BN, GM	74	84.6			
NH20	Standard	AN, EM	69.8	80.4	4.5	0.8	(14)
	Long	BN, GM	91.8	102.4			
NH25	Standard	AL, AN, EM	79.0	90.6	5.0	0.8	(14)
	Long	BL, BN, GM	107	118.6			
NH30	Standard	AL, AN	85.6	97.6	5.0	1.0	(14)
	Long	EM	98.6	110.6			
NH35	Standard	AL, AN, EM	109	122	5.5	1.0	(14)
	Long	BL, BN, GM	143	156			
NH45	Standard	AL, AN, EM	139	154	6.5	1.0	(15)
	Long	BL, BN, GM	171	186			
NH55	Standard	AL, AN, EM	163	178	6.5	1.0	(15)
	Long	BL, BN, GM	201	216			
NH65	Standard	AN, EM	193	211	8.0	1.0	(16)
	Long	BN, GM	253	271			

Notes: 1) NSK K1 for food and medical equipments are available for NH15 to NH35.

2) Ball slide length equipped with NSK K1 = (Standard ball slide length) + (Thickness of NSK K1, V₁ × Number of NSK K1) + (Thickness of the protective cover, V₂ × 2)

(3) Double seal

Use a double seal set as showing in **Table 14**, when installing an extra seal to completed standard products. **(Fig. 14)**

When installing a grease fitting after the installation of double seals, a connector as showing in **Fig.14** is required.

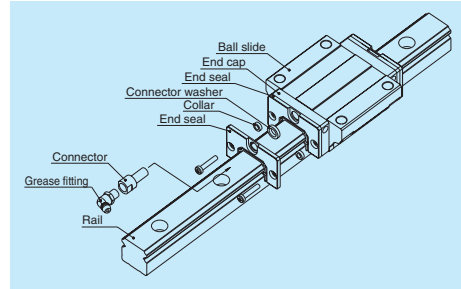

Fig. 14 Double seal

(4) Protector

Use a protector set as showing **Table 15**, when installing a protector to completed standard products. **(Fig.15)**

When installing a grease fitting after the installation of protectors, a connector as showing in **Fig.15** is required.

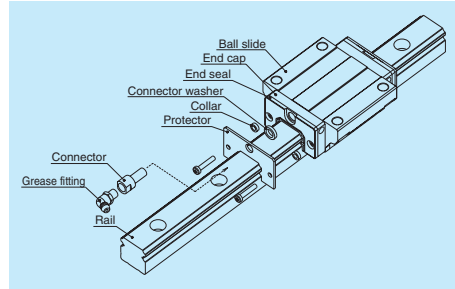

Fig. 15 Protector

Table 14 Double-seal set

Model No.	Reference No.		Increased thickness V_3 (mm)
	Without connector	With connector	
NH15	LH15WS-01	*	2.5
NH20	LH20WS-01	LH20WSC-01	2.5
NH25	LH25WS-01	LH25WSC-01	2.8
NH30	LH30WS-01	LH30WSC-01	3.6
NH35	LH35WS-01	LH35WSC-01	3.6
NH45	LH45WS-01	LH45WSC-01	4.3
NH55	LH55WS-01	LH55WSC-01	4.3
NH65	LH65WS-01	LH65WSC-01	4.9

Table 15 Protector set

Model No.	Reference No.		Increased thickness V_4 (mm)
	Without connector	With connector	
NH15	LH15PT-01	*	2.7
NH20	LH20PT-01	LH20PTC-01	2.9
NH25	LH25PT-01	LH25PTC-01	3.2
NH30	LH30PT-01	LH30PTC-01	4.2
NH35	LH35PT-01	LH35PTC-01	4.2
NH45	LH45PT-01	LH45PTC-01	4.9
NH55	LH55PT-01	LH55PTC-01	4.9
NH65	LH65PT-01	LH65PTC-01	5.5

*) For installation of a connector to a drive-in type grease fitting, contact NSK.

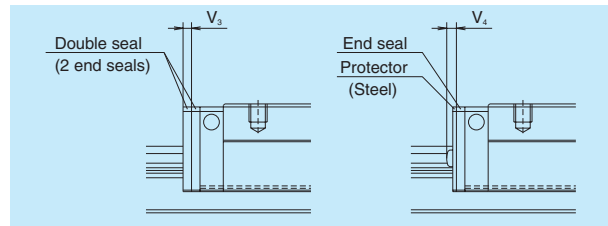

Fig. 16

(5) Cap to plug the rail mounting bolt hole

Table 16 Caps to plug rail bolt hole

Model No.	Bolt to secure rail	Cap reference No.	Quantity /case
NH15	M4	LG-CAP/M4	20
NH20	M5	LG-CAP/M5	20
NH25	M6	LG-CAP/M6	20
NH30, NH35	M8	LG-CAP/M8	20
NH45	M12	LG-CAP/M12	20
NH55	M14	LG-CAP/M14	20
NH65	M16	LG-CAP/M16	20

(7) Bellows

- A bellows fastener kit, which includes one of bellows faster, two of M_1 set screws, two of M_2 set screws, and two collars for M_2 set screws as showing Fig. 7.7 on page A55, is supplied with ellows for the ends.
- Middle bellows are supplied with four set screws and four collars.
- Use a bellows fastener kit as showing **Table 18**, when installing bellows to completed standard products.
- When NSK K1, double seals or protectors are used, the set screws of bellows fastener kit are unable to use. Please contact NSK for details.
- Bellows fastener is available only for the horizontal mounting positions. For other mounting positions, sliding plate is required (see **Fig. 7.10** on page A56).

For fixing to the rail, make tap holes to the rail end surface. Fix the bellows mounting plate to the rail end surface through these tap holes by using a machine screw. NSK processes a tap hole to the rail end face when ordered with a linear guide.

(6) Inner seal

Inner seal is only available for models shown in the table below.

Table 17

Series	Model No.
NH	NH20, NH25, NH30, NH35, NH45, NH55, NH65

Table 18 Bellows fastner kit reference No.

Model No.	Kit reference No.
NH20	LH20FS-01
NH25	LH25FS-01
NH30	LH30FS-01
NH35	LH35FS-01
NH45	LH45FS-01
NH55	LH55FS-01
NH65	LH65FS-01

Dimension tables of bellows
NH Series

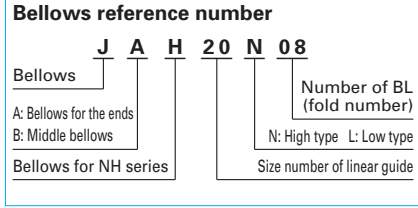
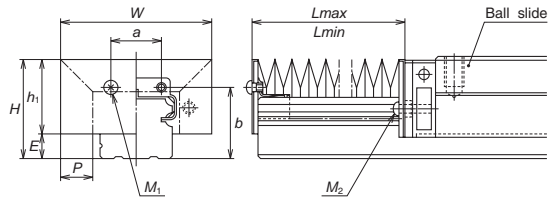

Fig. 17 Dimensions of bellows

Table 19 Dimensions of bellows

Unit: mm

Model No.	H	h ₁	E	W	P	a	b	BL minimum length	M ₁ Tap x depth	M ₂ Tap x depth
JAH20N	29.5	24.5	5	48	10	13	22	17	M3 × 5	M2.5 × 16
JAH25L	35	28	7	51	10	16	26	17	M3 × 5	M3 × 18
JAH25N	39	32		61	15					
JAH30L	41	32	9	60	12	18	31	17	M4 × 6	M4 × 22
JAH30N	44	35		66	15					
JAH35L	47	37.5	9.5	72	15	24	34	17	M4 × 6	M4 × 23
JAH35N	54	44.5		82	20					
JAH45L	59	45	14	83	15	32	44.5	17	M5 × 8	M5 × 28
JAH45N	69	55		103	25					
JAH55L	69	54	15	101	20	40	50.5	17	M5 × 8	M5 × 30
JAH55N	79	64		121	30					
JAH65N	89	73	16	131	30	48	61	17	M6 × 8	M6 × 35

Table 20 Numbers of folds (BL) and lengths of bellows

Unit: mm

Model No.	Number of BL	2	4	6	8	10	12	14	16	18	20
		L _{min}	34	68	102	136	170	204	238	272	306
JAH20N	Stroke	106	212	318	424	530	636	742	848	954	1 060
	L _{max}	140	280	420	560	700	840	980	1 120	1 260	1 400
JAH25L	Stroke	106	212	318	424	530	636	742	848	954	1 060
	L _{max}	140	280	420	560	700	840	980	1 120	1 260	1 400
JAH25N	Stroke	176	352	528	704	880	1 056	1 232	1 408	1 584	1 760
	L _{max}	210	420	630	840	1 050	1 260	1 470	1 680	1 890	2 100
JAH30L	Stroke	134	268	402	536	670	804	938	1 072	1 206	1 340
	L _{max}	168	336	504	672	840	1 008	1 176	1 344	1 512	1 680
JAH30N	Stroke	176	352	528	704	880	1 056	1 232	1 408	1 584	1 760
	L _{max}	210	420	630	840	1 050	1 260	1 470	1 680	1 890	2 100
JAH35L	Stroke	176	352	528	704	880	1 056	1 232	1 408	1 584	1 760
	L _{max}	210	420	630	840	1 050	1 260	1 470	1 680	1 890	2 100
JAH35N	Stroke	246	492	738	984	1 230	1 476	1 722	1 968	2 214	2 460
	L _{max}	280	560	840	1 120	1 400	1 680	1 960	2 240	2 520	2 800
JAH45L	Stroke	176	352	528	704	880	1 056	1 232	1 408	1 584	1 760
	L _{max}	210	420	630	840	1 050	1 260	1 470	1 680	1 890	2 100
JAH45N	Stroke	316	632	948	1 264	1 580	1 896	2 212	2 528	2 844	3 160
	L _{max}	350	700	1 050	1 400	1 750	2 100	2 450	2 800	3 150	3 500
JAH55L	Stroke	246	492	738	984	1 230	1 476	1 722	1 968	2 214	2 460
	L _{max}	280	560	840	1 120	1 400	1 680	1 960	2 240	2 520	2 800
JAH55N	Stroke	386	772	1 158	1 544	1 930	2 316	2 702	3 088	3 474	3 860
	L _{max}	420	840	1 260	1 680	2 100	2 520	2 940	3 360	3 780	4 200
JAH65N	Stroke	386	772	1 158	1 544	1 930	2 316	2 702	3 088	3 474	3 860
	L _{max}	420	840	1 260	1 680	2 100	2 520	2 940	3 360	3 780	4 200

Note: The values of an odd number BL quantity (3, 5, 7, ...) can be obtained by adding two values of even number BL on the both sides, then by dividing the sum by 2.

9. Reference number

Reference numbers shall be set to individual NSK linear guide when its specifications are finalized, and it is indicated on its specification drawing.
Please specify the reference number, except design serial number, to identify the product when ordering, requiring estimates, or inquiring about specifications from NSK.

(1) Reference number for preloaded assembly

NH 30 1200 ANC 2 - P5 3**

Series name	Preload code (See page A116.) 0: Z0, 1: Z1, 3: Z3
Size	Accuracy code (See Table 22.)
Rail length (mm)	Design serial number Added to the reference number.
Ball slide shape code (See page A114.)	Number of ball slides per rail
Material/surface treatment code (See Table 21.) C: Special high carbon steel (NSK standard), K: Stainless steel	

(2) Reference number for random-matching type

NAH 30 ANSZ -K

Ball slide	Option code -K: Equipped with NSK K1
Random-matching ball slide series code NAH: NH Series random-matching ball slide	-F: Fluoride low temperature chrome plating+AS2 grease -F50: Fluoride low temperature chrome plating+LG2 grease
Size	Preload code No code: Fine clearance, Z: Slight preload, H: Medium preload
Ball slide shape code (See page A114.)	Material code No code: Special high carbon steel (NSK standard), S: Stainless steel

Rail N1H30 1200 LCN - PC Z**

Rail	Preload code (See page A116.) T: Fine clearance Z: Slight preload (common rail for slight or medium preload)
Random-matching rail series code N1H: NH Series random-matching rail	Accuracy code PH: High precision grade random-matching type PC: Normal grade random-matching type
Size	Design serial number Added to the reference number.
Rail length (mm)	*Butting rail specification N: Non-butting, L: Butting specification
Rail shape code: L L: Standard	
Material/surface treatment code (See Table 21.)	

*Please consult with NSK for butting rail specification.

The reference number coding for the assembly of random-matching type is the same as that of the preloaded assembly. However, only preload codes of "fine clearance T", "slight preload Z" and "medium preload H" are available (refer to page A116).

Table 21 Material/surface treatment code

Code	Description
C	Special high carbon steel (NSK standard)
K	Stainless steel (NH15 to NH30 only)
D	Special high carbon steel with surface treatment
H	Stainless steel with surface treatment
Z	Other, special

Note: High-precision grade and medium preload of random-matching type are not available in stainless steel.

Table 22 Accuracy code

Accuracy	Standard (Without NSK K1)	With NSK K1	With NSK K1 for food and medical equipment
Ultra precision grade	P3	K3	F3
Super precision grade	P4	K4	F4
High precision grade	P5	K5	F5
Precision grade	P6	K6	F6
Normal grade	PN	KN	FN
High precision grade (random-matching type)	PH	KH	FH
Normal grade (random-matching type)	PC	KC	FC

Note: Refer to pages A38 and A61 for NSK K1 lubrication unit.

10. Dimensions
NH-AN (High-load type / Standard)
NH-BN (Super-high-load type / Long)

NH 30 1200 ANC 2 - PC Z**

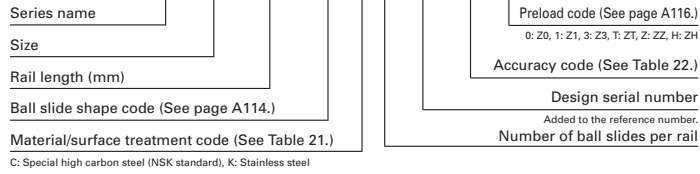

Front view of AN and BN types

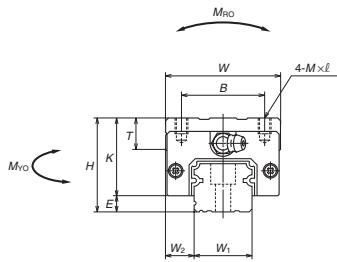

Side view of AN type

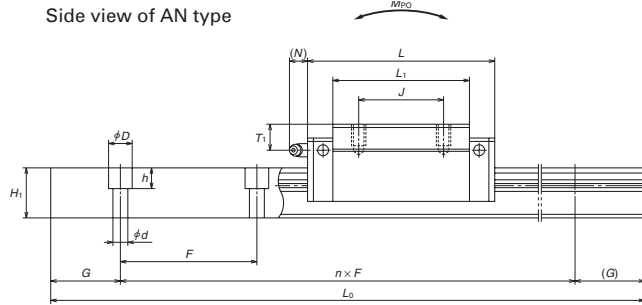

Side view of BN type

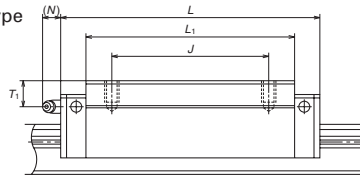

Model No.	Assembly			Ball slide											Width	Height
	Height	Width	Length	Mounting hole						Grease fitting						
				B	J	M x pitch x l	L1	K	T	Hole size	T1	N	W1	H1		
NH15AN	28	4.6	9.5	34	55	26	26	M4x0.7x6	39	23.4	8	phi 3	8.5	3.3	15	15
NH15BN					74				58							
NH20AN	30	5	12	44	69.8	32	36	M5x0.8x6	50	25	12	M6x0.75	5	11	20	18
NH20BN					91.8				72							
NH25AN	40	7	12.5	48	79	35	35	M6x1x9	58	33	12	M6x0.75	10	11	23	22
NH25BN					107				86							
NH30AN	45	9	16	60	85.6	40	40	M8x1.25x10	59	36	14	M6x0.75	10	11	28	26
NH30BN					124.6				98							
NH35AN	55	9.5	18	70	109	50	50	M8x1.25x12	80	45.5	15	M6x0.75	15	11	34	29
NH35BN					143				114							
NH45AN	70	14	20.5	86	139	60	60	M10x1.5x17	105	56	17	Rc1/8	20	13	45	38
NH45BN					171				137							
NH55AN	80	15	23.5	100	163	75	75	M12x1.75x18	126	65	18	Rc1/8	21	13	53	44
NH55BN					201				164							
NH65AN	90	16	31.5	126	193	76	70	M16x2x20	147	74	23	Rc1/8	19	13	63	53
NH65BN					253				207							

Notes: 1) External appearance of stainless steel ball slides differs from those of carbon steel ball slides.

Reference number for ball slide of random-matching type

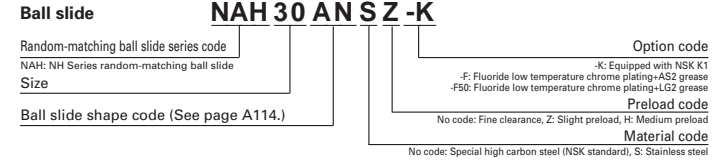

AN and BN types

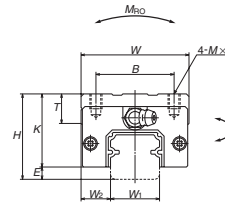

AN type

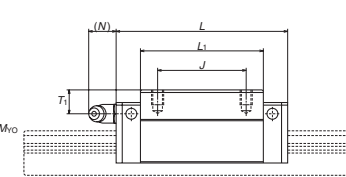

BN type

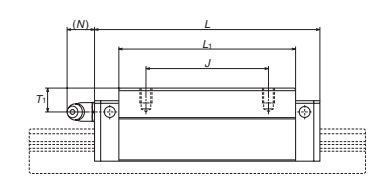

Reference number for rail of random-matching type

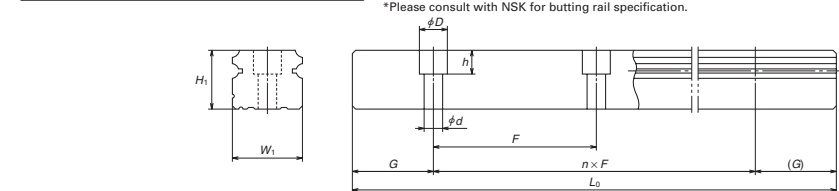
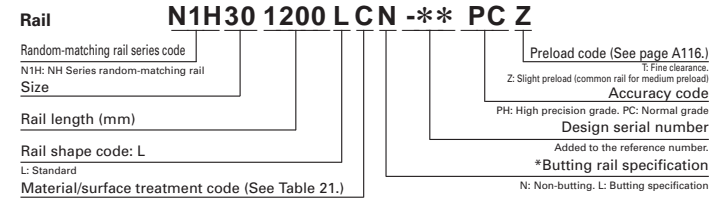

Unit: mm

Rail	Pitch	Mounting bolt hole	G	Max. length L _{max} () for stainless	Basic load rating						Weight		
					Dynamic		Static	Static moment (N-m)				Ball slide	Rail
					[50km]	[100km]		M _{PO}		M _{NO}			
60	4.5x7.5x5.3	20	2 980 (1 800)	14 200	11 300	20 700	108	94.5	575	480	0.18	1.6	
				18 100	14 400	32 000	166	216	1 150	181	965		0.26
60	6x9.5x8.5	20	3 960 (3 500)	23 700	18 800	32 500	219	185	1 140	155	955	0.33	2.6
				30 000	24 000	50 500	340	420	2 230	355	1 870	0.48	
60	7x11x9	20	3 960 (3 500)	33 500	26 800	46 000	360	320	1 840	267	1 540	0.55	3.6
				45 500	36 500	71 000	555	725	3 700	610	3 100	0.82	
80	9x14x12	20	4 000 (3 500)	41 000	32 500	51 500	490	350	2 290	292	1 920	0.77	5.2
				61 000	48 500	91 500	870	1 030	5 600	865	4 700	1.3	
80	9x14x12	20	4 000	62 500	49 500	80 500	950	755	4 500	630	3 800	1.5	7.2
				81 000	64 500	117 000	1 380	1 530	8 350	1 280	7 000	2.1	
105	14x20x17	22.5	3 990	107 000	84 500	140 000	2 140	1 740	9 750	1 460	8 150	3.0	12.3
				131 000	104 000	187 000	2 860	3 000	15 600	2 520	13 100	3.9	
120	16x23x20	30	3 960	158 000	125 000	198 000	3 600	3 000	16 300	2 510	13 700	4.7	16.9
				193 000	153 000	264 000	4 850	5 150	26 300	4 350	22 100	6.1	
150	18x26x22	35	3 900	239 000	190 000	281 000	6 150	4 950	27 900	4 150	23 400	7.7	24.3
				310 000	246 000	410 000	8 950	10 100	51 500	8 450	43 500	10.8	

2) The basic load rating comply with the ISO standard. (ISO 14728-1, 14728-2)
 C₅₀; the basic dynamic load rating for 50 km rated fatigue life C₁₀₀; the basic dynamic load rating for 100 km rated fatigue life
 The basic static load rating shows static permissible load.
 3) High-precision grade and medium preload of random-matching type are available for high-carbon steel products.

NH-AL (High-load type / Standard)
NH-BL (Super-high-load type / Long)

NH 30 1200 AL C 2 - PC Z**

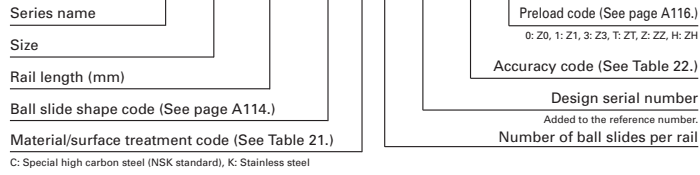

Front view of AL and BL types

Side view of AL type

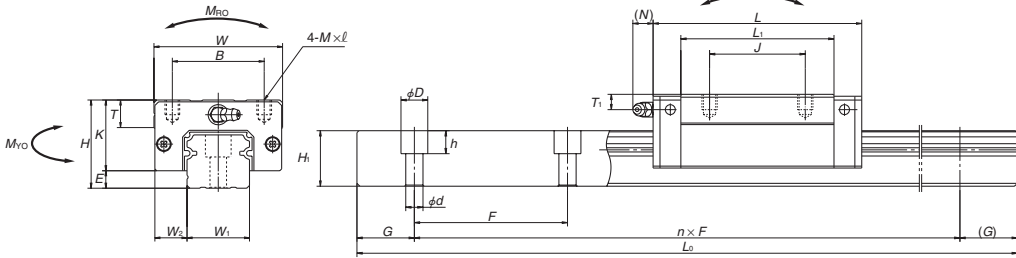

Side view of BL type

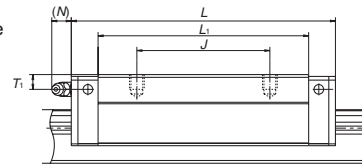

Model No.	Assembly			Ball slide											Width	Height
	Height	Width	Length	Mounting hole						Grease fitting			Width	Height		
				B	J	M × pitch × l	L ₁	K	T	Hole size	T ₁	N				
NH25AL NH25BL	36	7	12.5	48	79 107	35	35 50	M6×1×6	58 86	29	12	M6×0.75	6	11	23	22
NH30AL NH30BL	42	9	16	60	85.6 124.6	40	40 60	M8×1.25×8	59 98	33	14	M6×0.75	7	11	28	26
NH35AL NH35BL	48	9.5	18	70	109 143	50	50 72	M8×1.25×8	80 114	38.5	15	M6×0.75	8	11	34	29
NH45AL NH45BL	60	14	20.5	86	139 171	60	60 80	M10×1.5×10	105 137	46	17	Rc1/8	10	13	45	38
NH55AL NH55BL	70	15	23.5	100	163 201	75	75 95	M12×1.75×13	126 164	55	15	Rc1/8	11	13	53	44

Notes: 1) External appearance of stainless steel ball slides differs from those of carbon steel ball slides.

Reference number for ball slide of random-matching type

Ball slide NAH 30 AL SZ -K

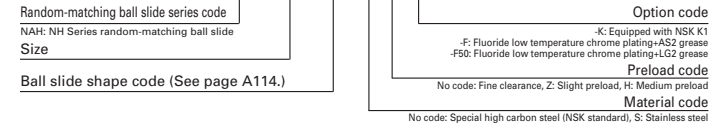

AL and BL types

AL type

BL type

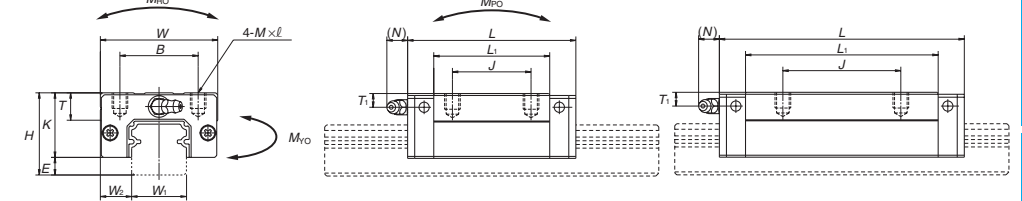

Reference number for rail of random-matching type

Rail N1H30 1200 LCN - PC Z**

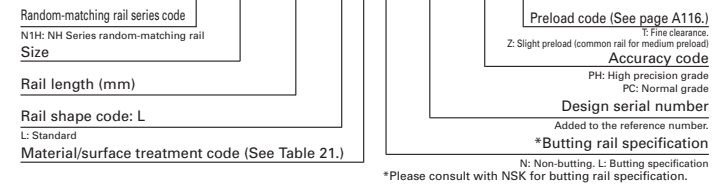

*Please consult with NSK for butting rail specification.

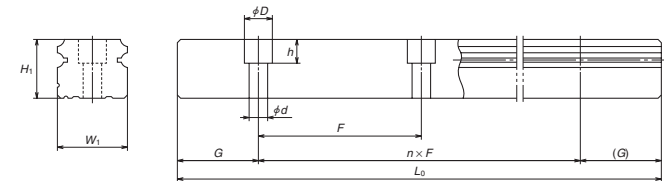

Unit: mm

Rail		Basic load rating										Weight	
Pitch	Mounting bolt hole	G	Max. length L _{max} () for stainless	²⁾ Dynamic		Static C ₀ (N)	Static moment (N-m)				Ball slide	Rail	
				[50km] C ₅₀ (N)	[100km] C ₁₀₀ (N)		M _{FC0}		M _{FCV}				
							One slide	Two slides	One slide	Two slides			
60	7×11×9	20	3 960 (3 500)	33 500	26 800	46 000	360	320	1 840	267	1 540	0.46	3.6
				45 500	36 500	71 000	555	725	3 700	610	3 100	0.69	
80	9×14×12	20	4 000 (3 500)	41 000	32 500	51 500	490	350	2 290	292	1 920	0.69	5.2
				61 000	48 500	91 500	870	1 030	5 600	865	4 700	1.16	
80	9×14×12	20	4 000	62 500	49 500	80 500	950	755	4 500	630	3 800	1.2	7.2
				81 000	64 500	117 000	1 380	1 530	8 350	1 280	7 000	1.7	
105	14×20×17	22.5	3 990	107 000	84 500	140 000	2 140	1 740	9 750	1 460	8 150	2.2	12.3
				131 000	104 000	187 000	2 860	3 000	15 600	2 520	13 100	2.9	
120	16×23×20	30	3 960	158 000	125 000	198 000	3 600	3 000	16 300	2 510	13 700	3.7	16.9
				193 000	153 000	264 000	4 850	5 150	26 300	4 350	22 100	4.7	

2) The basic load rating comply with the ISO standard. (ISO 14728-1, 14728-2)

C₅₀: the basic dynamic load rating for 50 km rated fatigue life C₁₀₀: the basic dynamic load rating for 100 km rated fatigue life
 The basic static load rating shows static permissible load.

3) High-precision grade and medium preload of random-matching type are available for high-carbon steel products.

NH-EM (High-load type / Standard)
NH-GM (Super-high-load type / Long)

NH 30 1200 EM C 2 -** PC Z

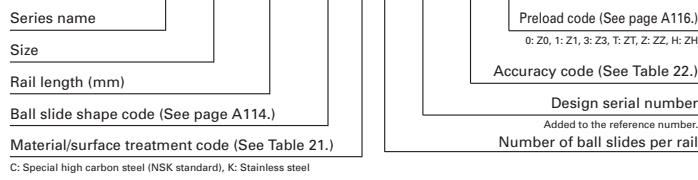

Front view of EM and GM types

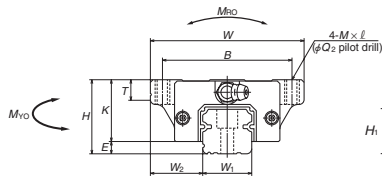

Side view of EM type

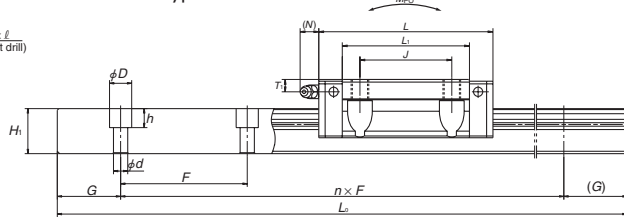

Side view of GM type

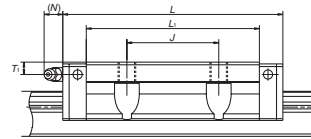

Model No.	Assembly			Ball slide											Width	Height	
	Height	E	W ₂	W	Length	Mounting hole					Grease fitting	Width	Height				
						B	J	M × pitch × l	Q ₂	L ₁				K			T
NH15EM	24	4.6	16	47	55	38	30	M5×0.8×7	4.4	39	19.4	8	φ3	4.5	3.3	15	15
NH15GM					74					58							
NH20EM	30	5	21.5	63	69.8	53	40	M6×1×9.5	5.3	50	25	10	M6×0.75	5	11	20	18
NH20GM					91.8					72							
NH25EM	36	7	23.5	70	79	57	45	M8×1.25×10	6.8	58	29	11	M6×0.75	6	11	23	22
NH25GM					107			(M8×1.25×11.5)		86		(12)					
NH30EM	42	9	31	90	98.6	72	52	M10×1.5×12	8.6	72	33	11	M6×0.75	7	11	28	26
NH30GM					124.6			(M10×1.5×14.5)		98		(15)					
NH35EM	48	9.5	33	100	109	82	62	M10×1.5×13	8.6	80	38.5	12	M6×0.75	8	11	34	29
NH35GM					143					114							
NH45EM	60	14	37.5	120	139	100	80	M12×1.75×15	10.5	105	46	13	Rc1/8	10	13	45	38
NH45GM					171					137							
NH55EM	70	15	43.5	140	163	116	95	M14×2×18	12.5	126	55	15	Rc1/8	11	13	53	44
NH55GM					201					164							
NH65EM	90	16	53.5	170	193	142	110	M16×2×24	14.6	147	74	23	Rc1/8	19	13	63	53
NH65GM					253					207							

Notes: 1) Parenthesized dimensions are for items made of stainless steel.

2) External appearance of stainless steel ball slides differs from those of carbon steel ball slides.

Reference number for ball slide of random-matching type

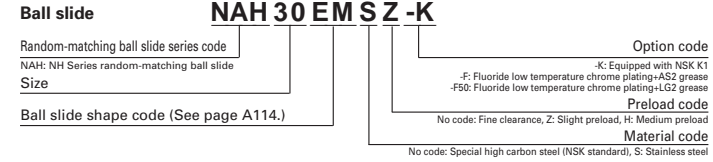

EM and GM types

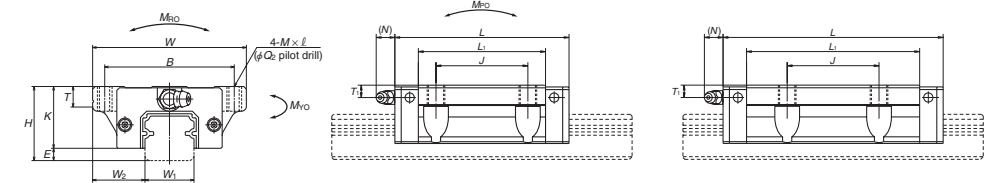

Reference number for rail of random-matching type

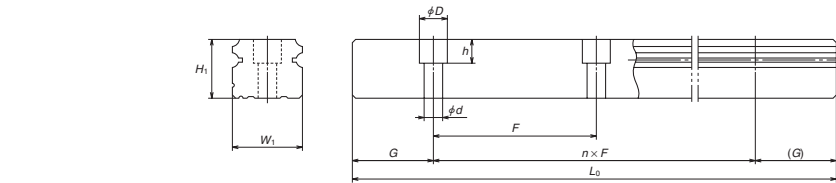
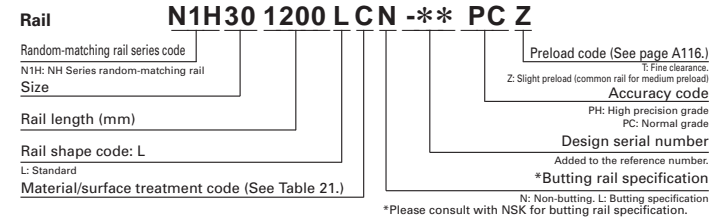

Unit: mm

Rail				Basic load rating								Weight	
Pitch	Mounting bolt hole	G	Max. length L _{max} () for stainless	³ Dynamic		C ₀ (N)	M _{ro}	Static moment (N-m)				Ball slide (kg)	Rail (kg/m)
				[50km] C ₅₀ (N)	[100km] C ₁₀₀ (N)			One slide	Two slides	One slide	Two slides		
60	4.5×7.5×5.3	20	2 980 (1 800)	14 200	11 300	20 700	108	94.5	575	79.5	480	0.17	1.6
60	6×9.5×8.5	20	3 960 (3 500)	23 700	18 800	32 500	219	185	1 140	155	955	0.45	2.6
60	7×11×9	20	3 960 (3 500)	45 500	36 500	71 000	555	725	3 700	610	3 100	0.63	3.6
80	9×14×12	20	4 000 (3 500)	47 000	37 500	63 000	600	505	3 150	425	2 650	1.2	5.2
80	9×14×12	20	4 000	62 500	49 500	80 500	950	755	4 500	630	3 800	1.7	7.2
105	14×20×17	22.5	3 990	131 000	104 000	187 000	2 860	3 000	15 600	2 520	13 100	3.9	12.3
120	16×23×20	30	3 960	158 000	125 000	198 000	3 600	3 000	16 300	2 510	13 700	5	16.9
150	18×26×22	35	3 900	239 000	190 000	281 000	6 150	4 950	27 900	4 150	23 400	10	24.3
				310 000	246 000	410 000	8 950	10 100	51 500	8 450	43 500	14.1	

3) The basic load rating comply with the ISO standard. (ISO 14728-1, 14728-2)

C₅₀: the basic dynamic load rating for 50 km rated fatigue life C₁₀₀: the basic dynamic load rating for 100 km rated fatigue life The basic static load rating shows static permissible load.

4) High-precision grade and medium preload of random-matching type are available for high-carbon steel products.

A-5-1.2 VH Series

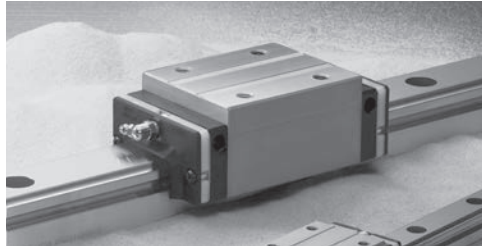

1. Features

(1) High-performance end seals

High-performance end seals with a multi-lip structure prevent the entry of various foreign matters.

(2) NSK K1™ lubrication unit (standard)

Outstanding lubrication support of NSK K1 further improves sealing capability and durability. Additional NSK K1 units can be mounted for specific usage conditions and environments.

(3) Tapped holes on a rail bottom surface (optional)

In addition to standard mounting bolt holes (counterbores on a rail top surface), a specification for tapped holes on a rail bottom surface for enhanced sealing capability is available for the VH Series. (Refer to the dimension table.)

(4) High self-aligning capability (rolling direction)

Same as the DF combination in angular contact bearings, self-aligning capability is high because the cross point of the contact lines of balls and grooves comes inside, reducing moment rigidity.

This increases the capacity to absorb errors in installation.

(5) High load carrying capacity to vertical direction

The contact angle is set at 50 degrees, thus increasing load carrying capacity as well as rigidity in vertical direction.

(6) High resistance against impact load

The bottom ball groove is formed in Gothic arch and the center of the top and bottom grooves are offset as shown in Fig. 2. The vertical load is generally carried by the top rows, at where balls are contacting at two points. Because of this design, the bottom rows will carry load when a large impact load

is applied vertically as shown in Fig. 3. This assures high resistance to the impact load.

(7) High accuracy

As showing in Fig. 4, fixing the master rollers to the ball grooves is easy thanks to the Gothic arch groove. This makes easy and accurate measuring of ball grooves.

(8) Random matching type

Random-matching of rails and ball slides are available.

(9) Improve rating life dramatically

New ball groove geometry is introduced,

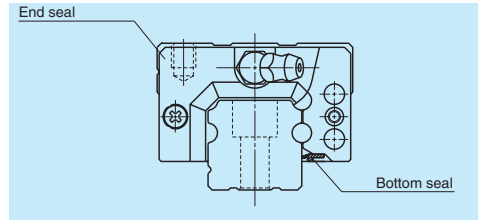

Fig. 1 VH Series

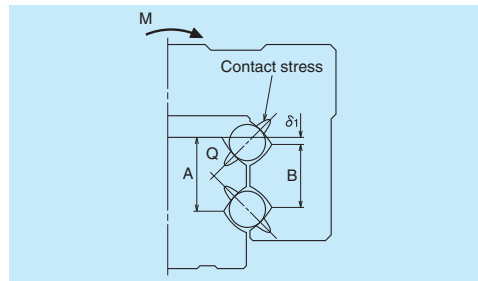

Fig. 2 Enlarged illustration of the offset Gothic arch groove

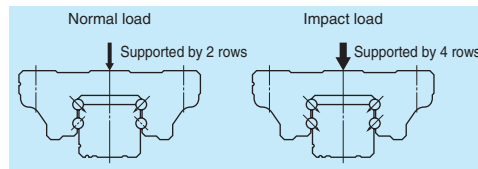

Fig. 3 When load is applied

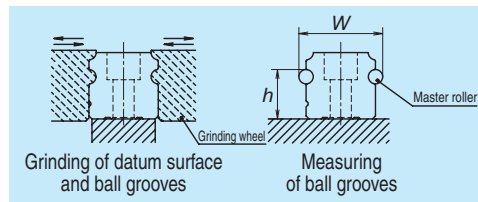

Fig. 4 Rail grinding and measuring

which has been developed by utilizing NSK's state-of-the-art tribological and analytical technologies. Due to the optimized distribution of contact surface pressures, the rating life has dramatically increased. As compared with the conventional products, the load rating capacity has increased to 1.3 times, while the life span has increased to twice^{*1}.

*1: Representative values of series.

●Comparison with NSK standard products

Less than 1/10 the level of fine contaminants
Results of dust-proof tests reveal that the entry of fine contaminants is reduced to less than one-tenth of existing standard series due to improvements in sealing capability.

Test sample : VH30AN
Speed : 16.7 mm/sec
Contaminant : Graphite powder (average grain size: 0.037 mm) + Grease

compared to the standard series, as shown in the graph.

Test sample : VH30AN (preload of 3 200 N)
Rail orientation : Horizontal (wall mount)
Speed : 400 mm/sec
Lubrication : AS2 grease (prepacked AS2 only)
Contaminant : Fine wood particles

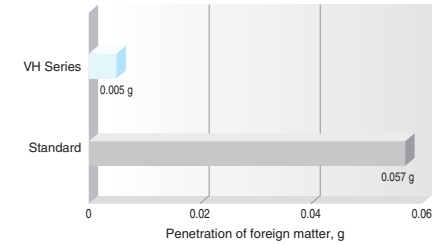

Operating life under contaminated environments is more than 5 times longer

Durability test with rubber fragments

Extreme durability tests under contaminated environments using rubber fragments show that durability of the VH Series extended more than five times longer than the existing standard series, as shown in the graph.

Test sample : VH30AN, preload code Z1 (preload of 245 N)
Rail orientation : Horizontal (wall mount)
Speed : 500 mm/sec
Lubrication : AS2 grease (prepacked AS2 only)
Contaminant : Rubber fragments

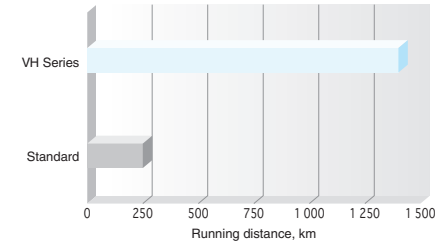

Durability test with fine wood particles

Extreme durability tests in a contaminated environment with fine wood particles show that durability of the VH Series is more than doubled

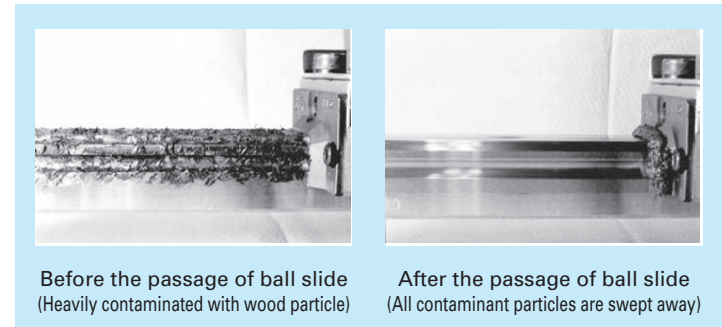
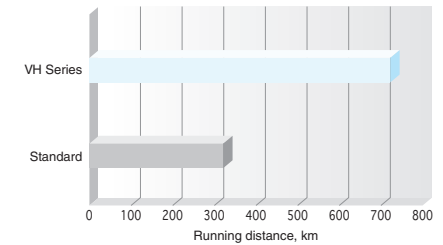

Before the passage of ball slide (Heavily contaminated with wood particle)

After the passage of ball slide (All contaminant particles are swept away)

The data shown in the catalog are the results of our tests, and no warranty is given to sealing performance on actual usage on machinery. Sealing performance is affected by usage environment and lubrication conditions. Dust covers and other measures to keep machinery free of dust are recommended.

2. Ball slide shape

Ball slide Model	Shape/installation method	Type (Upper row, Rating: Lower row, Ball slide length)	
		High-load type Standard	Super-high-load type Long
AN BN		AN	BN
AL BL		AL	BL
EM GM		EM	GM

3. Accuracy and preload

(1) Running parallelism of ball slide

Table 1

Unit: μm

Rail length (mm) over or less	Preloaded assembly (not random matching)					Random-matching type
	Ultra precision K3	Super precision K4	High precision K5	Precision grade K6	Normal grade KN	Normal grade KC
– 50	2	2	2	4.5	6	6
50 – 80	2	2	3	5	6	6
80 – 125	2	2	3.5	5.5	6.5	6.5
125 – 200	2	2	4	6	7	7
200 – 250	2	2.5	5	7	8	8
250 – 315	2	2.5	5	8	9	9
315 – 400	2	3	6	9	11	11
400 – 500	2	3	6	10	12	12
500 – 630	2	3.5	7	12	14	14
630 – 800	2	4.5	8	14	16	16
800 – 1 000	2.5	5	9	16	18	18
1 000 – 1 250	3	6	10	17	20	20
1 250 – 1 600	4	7	11	19	23	23
1 600 – 2 000	4.5	8	13	21	26	26
2 000 – 2 500	5	10	15	22	29	29
2 500 – 3 150	6	11	17	25	32	32
3 150 – 4 000	9	16	23	30	34	34

(2) Accuracy standard

The preloaded assembly has five accuracy grades; Ultra precision K3, Super precision K4, High precision K5, Precision K6, and Normal KN grades, while the random-matching type has Normal KC grade only.

• Tolerance of preloaded assembly

Table 2

Unit: μm

Characteristics	Accuracy grade	Ultra precision K3	Super precision K4	High precision K5	Precision grade K6	Normal grade KN
Mounting height H Variation of H (All ball slides on a set of rails)		± 10 3	± 10 5	± 20 7	± 40 15	± 80 25
Mounting width W_2 or W_3 Variation of W_2 or W_3 (All ball slides on reference rail)		± 15 3	± 15 7	± 25 10	± 50 20	± 100 30
Running parallelism of surface C to surface A Running parallelism of surface D to surface B		Shown in Table 1, Fig. 5 and Fig. 6				

• Tolerance of random-matching type: Normal grade KC

Table 3

Unit: μm

Model No.	VH15, 20, 25, 30, 35	VH45, 55
Characteristics		
Mounting height H	± 20	± 30
Variation of mounting height H	15 ^① 30 ^②	20 ^① 35 ^②
Mounting width W_2 or W_3	± 30	± 35
Variation of mounting width W_2 or W_3	25	30
Running parallelism of surface C to surface A Running parallelism of surface D to surface B	See Table 1, Fig. 5 and Fig. 6	

Note: ① Variation on the same rail ② Variation on multiple rails

(3) Combinations of accuracy and preload

Table 4

		Accuracy grade					
		Ultra precision	Super precision	High Precision	Precision grade	Normal grade	Normal grade
With NSK K1 lubrication unit		K3	K4	K5	K6	KN	KC
Preload	Fine clearance Z0	○	○	○	○	○	—
	Slight preload Z1	○	○	○	○	○	—
	Medium preload Z3	○	○	○	○	—	—
	Random-matching type with fine clearance ZT	—	—	—	—	—	○
	Random-matching type with slight preload ZZ	—	—	—	—	—	○

(4) Assembled accuracy

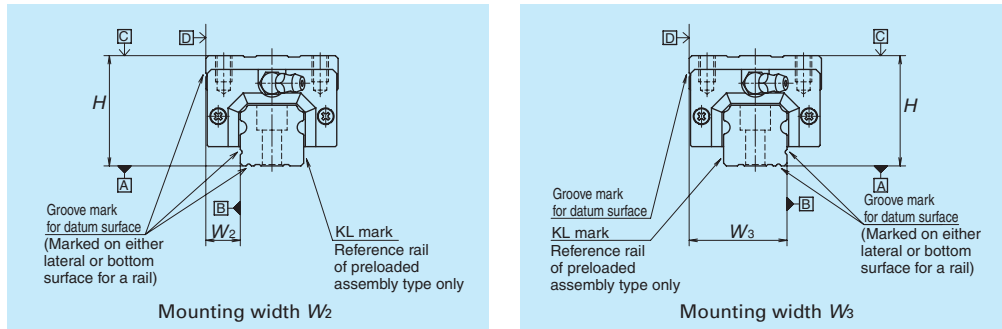

Fig. 5 Special high carbon steel

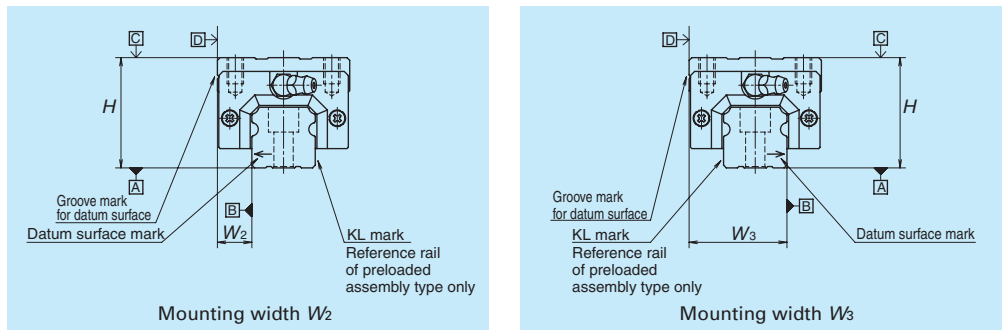

Fig. 6 Stainless steel

(5) Preload and rigidity

We offer five levels of preload: Slight preload Z1, Medium preload Z3 and Fine clearance Z0, along with random-matching type of Fine clearance ZT and Slight preload ZZ.

• Preload and rigidity of preloaded assembly

Table 5

Model No.		Preload (N)		Rigidity (N/μm)			
		Slight preload Z1		Vertical direction		Lateral direction	
				Medium preload Z3	Slight preload Z1	Medium preload Z3	Slight preload Z1
High-load type	VH15 AN, EM	78	490	137	226	98	186
	VH20 AN, EM	147	835	186	335	137	245
	VH25 AN, AL, EM	196	1 270	206	380	147	284
	VH30 AN, AL	245	1 570	216	400	157	294
	VH30 EM	294	1 770	265	480	186	355
	VH35 AN, AL, EM	390	2 350	305	560	216	390
	VH45 AN, AL, EM	635	3 900	400	745	284	540
Super-high-load type	VH55 AN, AL, EM	980	5 900	490	910	345	645
	VH15 BN, GM	98	685	196	345	137	284
	VH20 BN, GM	196	1 080	265	480	196	355
	VH25 BN, BL, GM	245	1 570	294	560	216	400
	VH30 BN, BL, GM	390	2 260	360	665	265	480
	VH35 BN, BL, GM	490	2 940	430	795	305	570
	VH45 BN, BL, GM	785	4 800	520	960	370	695
	VH55 BN, BL, GM	1 180	7 050	635	1 170	440	835

Note: Clearance for Fine clearance Z0 is 0 to 3 μm. Therefore, preload is zero. However, Z0 of PN grade is 0 to 15 μm.

• Preload of random-matching type

Table 6

Unit: μm

Model No.	Fine clearance ZT	Slight preload ZZ
	VH15	-4 - 15
VH20	-5 - 15	-5 - 0
VH25		-5 - 0
VH30		-7 - 0
VH35		-7 - 0
VH45		-7 - 0
VH55		-9 - 0

Note: Minus sign denotes that a value is an amount of preload (elastic deformation of balls).

4. Maximum rail length

Table 7 shows the limitations of rail length (maximum length). However, the limitations vary by accuracy grade.

Table 7 Length limitations of rails

Unit: mm

Series	Size	15	20	25	30	35	45	55
	Material							
VH	Special high carbon steel	2 000	3 960	3 960	4 000	4 000	3 990	3 960
	Stainless steel	1 800	3 500	3 500	3 500			

Note: Rails can be butted if user requirement exceeds the rail length shown in the table. Please consult NSK.

5. Installation

(1) Permissible values of mounting error

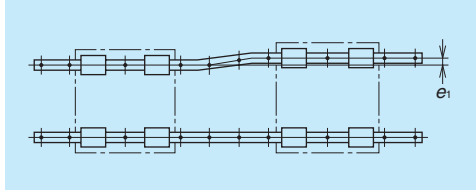

Fig. 7

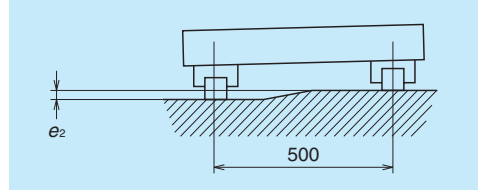

Fig. 8

Table 8

Unit: μm

Value	Preload	Model No.						
		VH15	VH20	VH25	VH30	VH35	VH45	VH55
Permissible values of parallelism in two rails e_1	Z0, ZT	22	30	40	45	55	65	80
	Z1, ZZ	18	20	25	30	35	45	55
	Z3	13	15	20	25	30	40	45
Permissible values of parallelism (height) in two rails e_2	Z0, ZT	375 μm /500 mm						
	Z1, ZZ, Z3	330 μm /500 mm						

(2) Shoulder height of the mounting surface and corner radius r

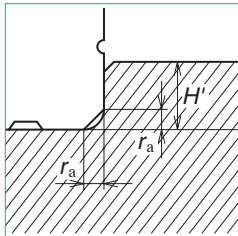

Fig. 9 Shoulder for the rail datum surface

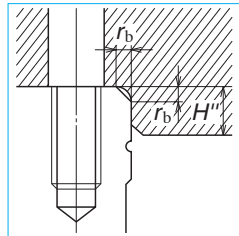

Fig. 10 Shoulder for the ball slide datum surface

Table 9

Unit: mm

Model No.	Corner radius (maximum)		Shoulder height	
	r_a	r_b	H'	H''
VH15	0.5	0.5	4	4
VH20	0.5	0.5	4.5	5
VH25	0.5	0.5	5	5
VH30	0.5	0.5	6	6
VH35	0.5	0.5	6	6
VH45	0.7	0.7	8	8
VH55	0.7	0.7	10	10

(3) Specification for tapped holes on a rail bottom surface

- Special high carbon steel is available for this specification.
- Applicable accuracy grades are precision grade (K6) and normal grades (KN and KC) only.
- The minimum rail length for production is 400 mm.
- The tapping pitch is the same as the pitch for regular mounting bolt holes. Please refer to the dimension table.

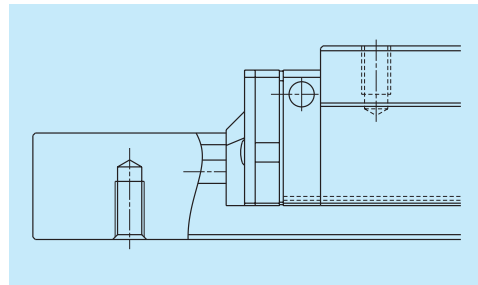

Fig. 11

6. Lubrication components

Refer to pages A38 and D13 for the lubrication of linear guides.

(1) Types of lubrication accessories

Fig. 12 and Table 10 show grease fittings and tube fittings.

We provide lubrication accessories with extended thread body length (L) for the addition of dust-proof accessories such as NSK K1 lubrication unit, double seal and protector.

We provide a suitable lubrication accessory for the special requirement on dust-proof accessories.

Consult NSK for a lubrication accessory with extended length of thread body for your convenience of replenishing lubricant.

Please ask NSK for stainless lubrication accessories.

(2) Mounting position of lubrication accessories

The standard position of grease fittings is the end face of ball slide. We mount them on a side of end cap for an option. (Fig. 13)

Please consult NSK for installation of grease or tube fittings to the ball slide body or side of end cap.

When using a piping unit with thread of M6 \times 1, you require a connector to connect to a grease fitting mounting hole with M6 \times 0.75. The connector is available from NSK.

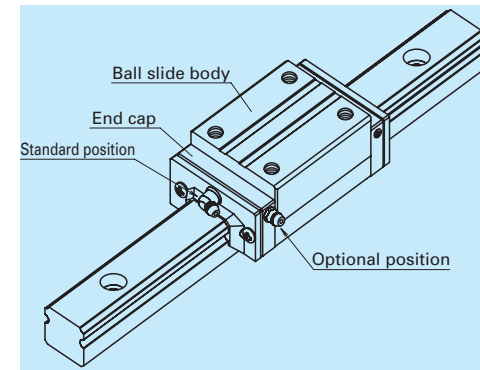
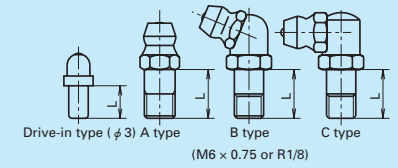

Fig. 13 Mounting position of lubrication accessories

Grease fitting



Tube fitting

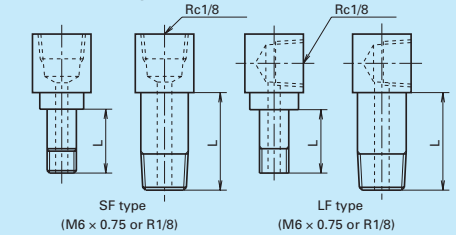

Fig. 12 Grease fitting and tube fitting

Table 10

Unit: mm

Model No.	Dust-proof specification	Dimension L		
		Grease fitting / Drive-in type	Tube fitting	
			SF type	LF type
VH15	Standard*	10	-	-
	Double seal	**	-	-
	Protector	**	-	-
VH20	Standard*	12	-	-
	Double seal	18	-	-
	Protector	18	-	-
VH25	Standard*	12	15	16
	Double seal	18	23	24.5***
	Protector	18	17	18
VH30	Standard*	14	18	17.5
	Double seal	22	25	24.5
	Protector	22	19.5	19
VH35	Standard*	14	15	15
	Double seal	22	25	24.5
	Protector	22	21.5	22
VH45	Standard*	18	22	21.5
	Double seal	22	32	32
	Protector	28	28	30
VH55	Standard*	18	20	20
	Double seal	22	32	32
	Protector	28	28	30

*) NSK K1 units are mounted as a standard specification for VH series.

**) A connector is required for grease fitting. Please contact NSK.

***) Only available for AN and BN type ball slides.

7. Dust-proof components

(1) Standard specification

To keep foreign matters from entering inside the ball slide, VH Series has an end seal on both ends, and bottom seals at the bottom.

Two NSK K1, one at each end, are installed as the standard equipment.

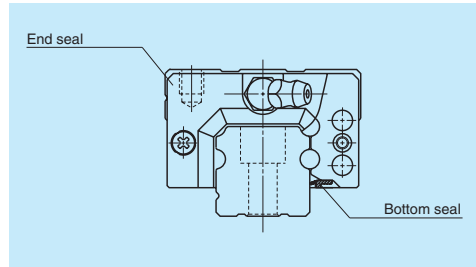

Fig. 14

Table 11 Seal friction per ball slide (maximum value)

Series	Size	Unit: N						
		15	20	25	30	35	45	55
VH		11	13	14	17	23	33	44

(2) Double seal and protector

For VH Series, double-seal and protector can be installed only before shipping from the factory. Please consult NSK when you require them.

Table 12 shows the ball slide length when a double seal set and a protector are installed.

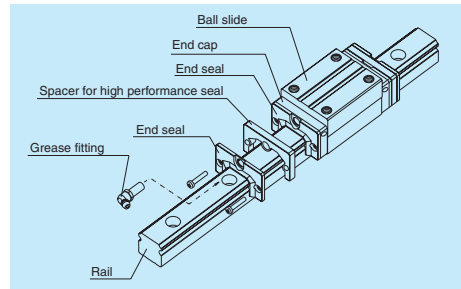

Fig. 15 Double seal

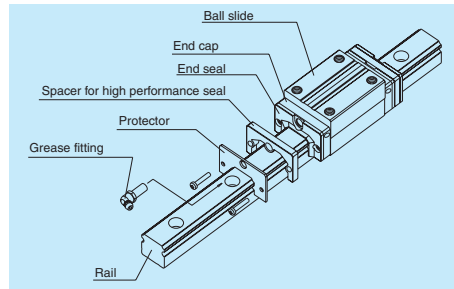

Fig. 16 Protector

Table 12 Dimension of installing dust-proof optional components

Unit: mm

Model No.	Ball slide length	Ball slide model	Ball slide length L		
			Standard	Double seal installation	Protector installation
VH15	Standard type	AN, EM	70.6	81.6	77
	Long type	BN, GM	89.6	100.6	96
VH20	Standard type	AN, EM	87.4	100.4	94.2
	Long type	BN, GM	109.4	122.4	116.2
VH25	Standard type	AN, AL, EM	97	110	104.4
	Long type	BN, BL, GM	125	138	132.4
VH30	Standard type	AN, AL, EM	104.4	120.4	114.8
	Long type	BN, BL, GM	143.4	159.4	153.8
VH35	Standard type	AN, AL, EM	128.8	144.8	139.2
	Long type	BN, BL, GM	162.8	178.8	173.2
VH45	Standard type	AN, AL, EM	161.4	180.4	174.2
	Long type	BN, BL, GM	193.4	212.4	206.2
VH55	Standard type	AN, AL, EM	185.4	204.4	198.2
	Long type	BN, BL, GM	223.4	242.4	236.2

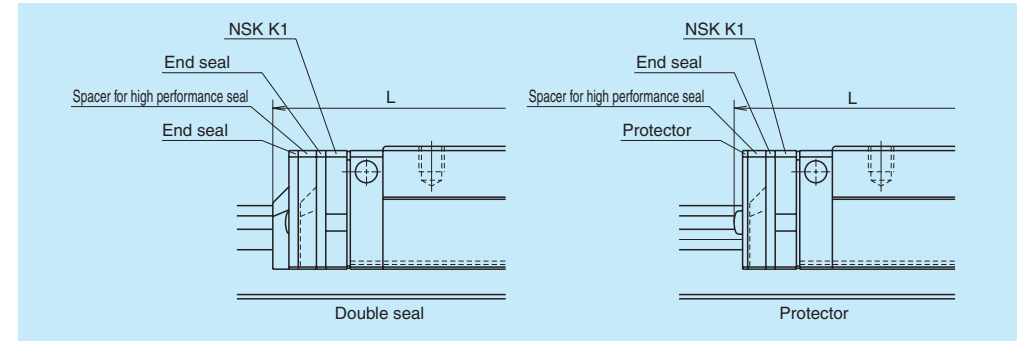

Fig. 17

(3) Cap to plug the rail mounting bolt hole

Table 13 Caps to plug rail bolt hole

Model No.	Bolt to secure rail	Cap reference No.	Quantity /case
VH15	M4	LG-CAP/M4	20
VH20	M5	LG-CAP/M5	20
VH25	M6	LG-CAP/M6	20
VH30, VH35	M8	LG-CAP/M8	20
VH45	M12	LG-CAP/M12	20
VH55	M14	LG-CAP/M14	20

(4) Inner seal

The availability of inner seal is limited to the models shown below.

Table 14

Series	Model No.
VH	VH20, VH25, VH30, VH45, VH55

8. Design Precautions

Because the product is used under severe operating conditions that require high performance end seals, please inform NSK about your service conditions using the technical data sheet on page A152.

8. Reference number

Reference numbers shall be set to individual NSK linear guide when its specifications are finalized, and it is indicated on its specification drawing.
Please specify the reference number, except design serial number, to identify the product when ordering, requiring estimates, or inquiring about specifications from NSK.

(1) Reference number for preloaded assembly

VH 30 1000 ANC 2 - K5 3**

Series name	Size	Rail length (mm)	Ball slide shape code (See page A135.)	Material/surface treatment code (See Table 15.) <small>C: Special high carbon steel (NSK standard), K: Stainless steel</small>	Preload code (See page A137.) <small>0: Z0, 1: Z1, 3: Z3</small>	Accuracy code (See Table 16.)	Design serial number	Number of ball slides per rail
-------------	------	------------------	--	---	---	-------------------------------	----------------------	--------------------------------

(2) Reference number for random-matching type

VAH 30 ANC -KCZ**

Random-matching ball slide series code <small>VAH: VH Series random-matching ball slide</small>	Size	Ball slide shape code (See page A135.)	Material/surface treatment code (See Table 15.)	Preload code <small>T: Fine clearance. Z: Slight preload (See page A137.)</small>	Accuracy code: KC <small>KC: Normal grade is only available.</small>	Design serial number
--	------	--	---	--	---	----------------------

Rail
V1H30 1000 L CN - PC Z**

Random-matching rail series code <small>V1H: VH Series random-matching rail</small>	Size	Rail length (mm)	Rail shape code: L <small>L: Standard</small>	Material/surface treatment code (See Table 15.)	Preload code (See page A137.) <small>T: Fine clearance. Z: Slight preload</small>	Accuracy code: PC <small>PC: Normal grade is only available.</small>	Design serial number	*Butting rail specification <small>N: Non-butting. L: Butting specification</small>
--	------	------------------	--	---	--	---	----------------------	--

*Please consult with NSK for butting rail specification.

The reference number coding for the assembly of random-matching type is the same as that of preloaded assembly. However, the preload code of "fine clearance T" and "slight preload Z" is only applicable (refer to page A137).

Table 15 Material/surface treatment code

Code	Description
C	Special high carbon steel (NSK standard) + counterbores on a rail top surface
K	Stainless steel + counterbores on a rail top surface
D	Special high carbon steel with surface treatment + counterbores on a rail top surface
H	Stainless steel with surface treatment + counterbores on a rail top surface
V	Special high carbon steel (NSK standard) + tapped holes on a rail bottom surface
W	Special high carbon steel with surface treatment + tapped holes on a rail bottom surface
Z	Other, special

Table 16 Accuracy code

Accuracy	Standard (with NSK K1)
Ultra precision grade	K3
Super precision grade	K4
High precision grade	K5
Precision grade	K6
Normal grade	KN
Normal grade (random-matching type)	KC

Note: Refer to page A38 for NSK K1 lubrication unit.

9. Dimensions
VH-AN (High-load type / Standard)
VH-BN (Super-high-load type/ Long)

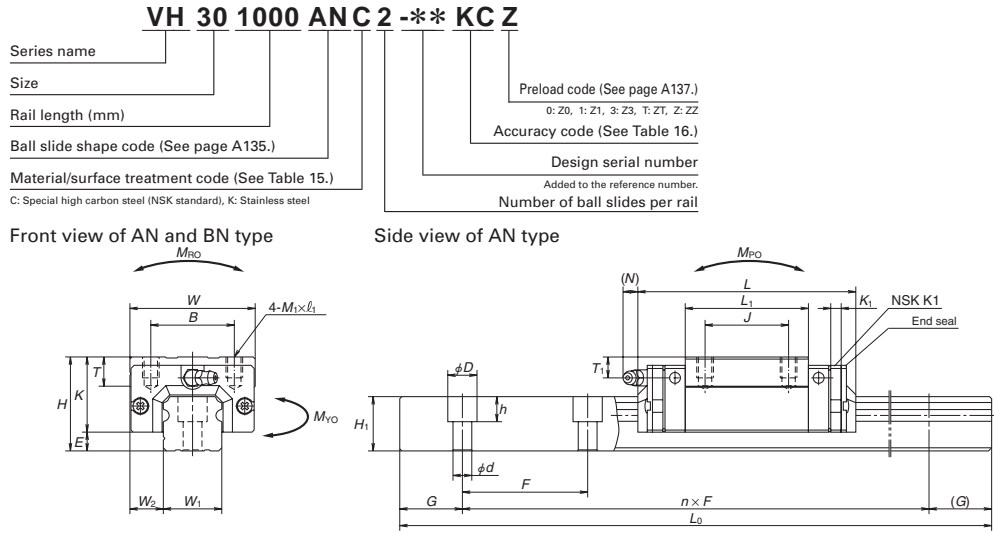

Specification for tapped holes on a rail bottom face

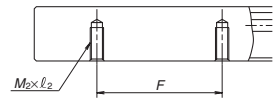

Model No.	Assembly		Ball slide											Width	Height		
	Height	E	Width	Length	Mounting hole			Grease fitting									
					B	J	M × pitch × l	L ₁	K	T	K ₁	Hole size	T ₁			N	W ₁
VH15AN VH15BN	28	4.6	9.5	34	70.6 (77) 89.6 (96)	26	26	M4×0.7×6	39 58	23.4	8	4.5	φ 3	8.5	1 (8.2)	15	15
VH20AN VH20BN	30	5	12	44	87.4 (94.2) 109.4 (116.2)	32	36	M5×0.8×6	50 72	25	12	4.5	M6×0.75	5	11.1 (12.3)	20	18
VH25AN VH25BN	40	7	12.5	48	97 (104.4) 125 (132.4)	35	35	M6×1×9	58 86	33	12	5	M6×0.75	10	9.6 (12.9)	23	22
VH30AN VH30BN	45	9	16	60	104.4 (114.8) 143.4 (153.8)	40	40	M8×1.25×10	59 98	36	14	5	M6×0.75	10	11.4 (14.2)	28	26
VH35AN VH35BN	55	9.5	18	70	128.8 (139.2) 162.8 (173.2)	50	50	M8×1.25×12	80 114	45.5	15	5.5	M6×0.75	15	10.9 (13.7)	34	29
VH45AN VH45BN	70	14	20.5	86	161.4 (174.2) 193.4 (206.2)	60	60	M10×1.5×17	105 137	56	17	6.5	Rc1/8	20	12.5 (14.1)	45	38
VH55AN VH55BN	80	15	23.5	100	185.4 (198.2) 223.4 (236.2)	75	75	M12×1.75×18	126 164	65	18	6.5	Rc1/8	21	12.5 (14.1)	53	44

- Notes: 1) Figure inside () is the dimension when equipped with the protector.
 2) VH Series does not have a ball retainer. Be aware that balls fall out when the ball slide is withdrawn from the rail.
 3) External appearance of stainless steel ball slides differs from those of carbon steel ball slides.

Reference number for ball slide of random-matching type

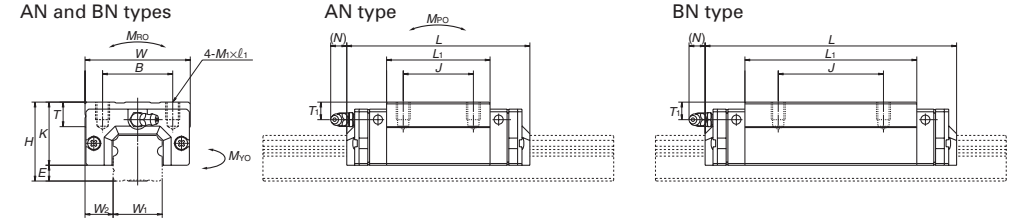
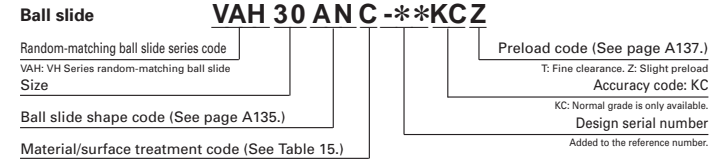

Reference number for rail of random-matching type

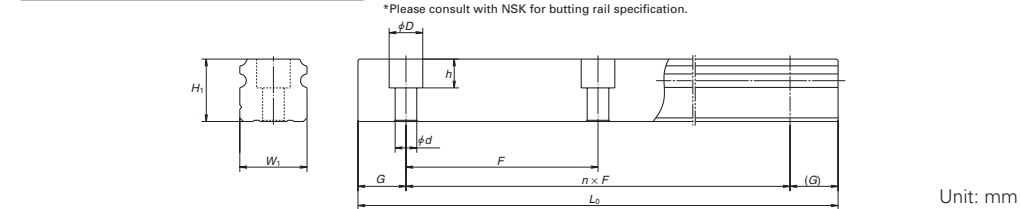
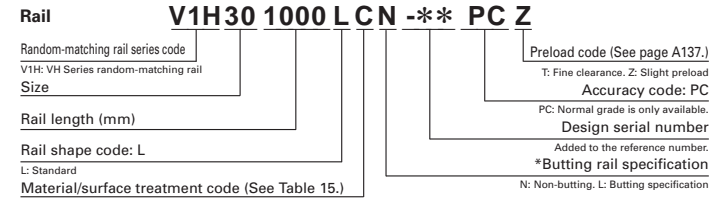

Pitch	Rail		G	Max. length L _{0max} () for stainless	Basic load rating						Weight			
	Mounting bolt hole	Tapped hole			Dynamic		Static	Static moment (N-m)				Ball slide (kg)	Rail (kg/m)	
					[50km]	[100km]		C ₀	M _{Ro}	M _{Vo}				
60	4.5×7.5×5.3	M5×0.8×8	20	2 000 [1 800]	14 200 18 100	11 300 14 400	20 700 32 000	108 166	94.5 216	575 1 150	79.5 181	480 965	0.18 0.26	1.6
60	6×9.5×8.5	M6×1×10	20	3 960 [3 500]	23 700 30 000	18 800 24 000	32 500 50 500	219 340	185 420	1 140 2 230	155 355	955 1 870	0.33 0.48	
60	7×11×9	M6×1×12	20	3 960 [3 500]	33 500 45 500	26 800 36 500	46 000 71 000	360 555	320 725	1 840 3 700	267 610	1 540 3 100	0.55 0.82	3.6
80	9×14×12	M8×1.25×15	20	4 000 [3 500]	41 000 61 000	32 500 48 500	51 500 91 500	490 870	350 1 030	2 290 5 600	292 865	1 920 4 700	0.77 1.3	
80	9×14×12	M8×1.25×17	20	4 000	62 500 81 000	49 500 64 500	80 500 117 000	950 1 380	755 1 530	4 500 8 350	630 1 280	3 800 7 000	1.5 2.1	7.2
105	14×20×17	M12×1.75×24	22.5	3 990	107 000 131 000	84 500 104 000	140 000 187 000	2 140 2 860	1 740 3 000	9 750 15 600	1 460 2 520	8 150 13 100	3.0 3.9	
120	16×23×20	M14×2×24	30	3 960	158 000 193 000	125 000 153 000	198 000 264 000	3 600 4 850	3 000 5 150	16 300 26 300	2 510 4 350	13 700 22 100	4.7 6.1	16.9

- 4) The basic load rating comply with the ISO standard. (ISO 14728-1, 14728-2)
 C_{50i}: the basic dynamic load rating for 50 km rated fatigue life C_{100i}: the basic dynamic load rating for 100 km rated fatigue life
 The basic static load rating shows static permissible load.

VH-AL (High-load type / Standard)
VH-BL (Super-high-load type / Long)

VH 30 1000 AL C 2 -** KC Z

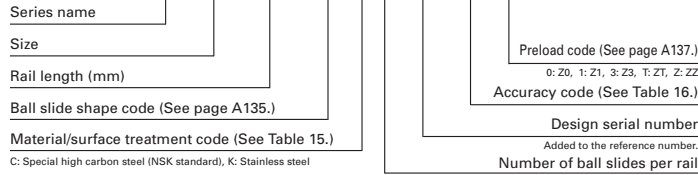

Front view of AL and BL type

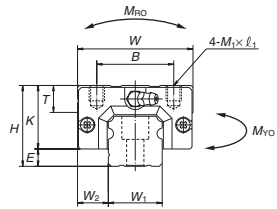

Side view of AL type

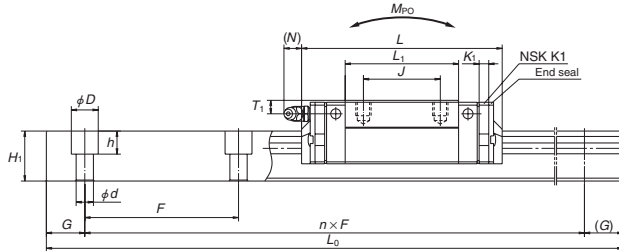

Specification for tapped holes on a rail bottom face

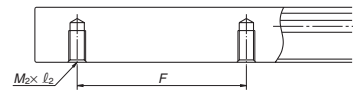

Side view of BL type

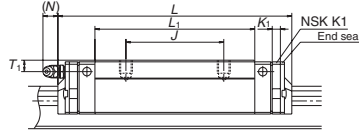

Model No.	Assembly		Ball slide											Width	Height		
	Height	Length	Width	Mounting hole				Grease fitting				Width	Height				
				B	J	M x pitch x l	L1	K	T	K1	Hole size					T1	N
VH25AL VH25BL	36	7	12.5	48	97 (104.4) 125 (132.4)	35	35 50	M6x1x6	58 86	29	12	5	M6x0.75	6	9.6 (12.9)	23	22
VH30AL VH30BL	42	9	16	60	104.4 (114.8) 143.4 (153.8)	40	40 60	M8x1.25x8	59 98	33	14	5	M6x0.75	7	11.4 (14.2)	28	26
VH35AL VH35BL	48	9.5	18	70	128.8 (139.2) 162.8 (173.2)	50	50 72	M8x1.25x8	80 114	38.5	15	5.5	M6x0.75	8	10.9 (13.7)	34	29
VH45AL VH45BL	60	14	20.5	86	161.4 (174.8) 193.4 (206.2)	60	60 80	M10x1.5x10	105 137	46	17	6.5	Rc1/8	10	12.5 (14.1)	45	38
VH55AL VH55BL	70	15	23.5	100	185.4 (198.2) 223.4 (236.2)	75	75 95	M12x1.75x13	126 164	55	15	6.5	Rc1/8	11	12.5 (14.1)	53	44

Notes: 1) Figure inside () is the dimension when equipped with the protector.

2) VH Series does not have a ball retainer. Be aware that balls fall out when the ball slide is withdrawn from the rail.

3) External appearance of stainless steel ball slides differs from those of carbon steel ball slides.

Reference number for ball slide of random-matching type

Ball slide VAH 30 AL C -** KC Z

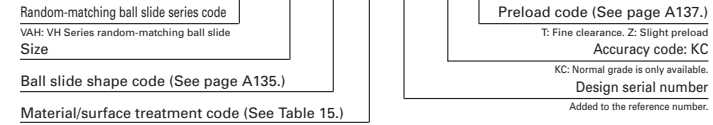

AL and BL types

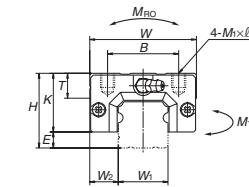

AL type

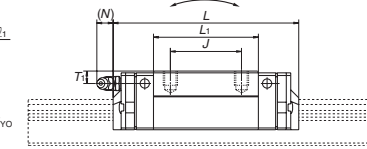

BL type

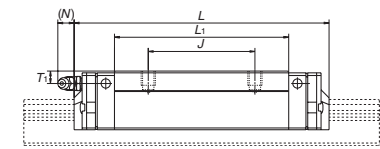

Reference number for rail of random-matching type

Rail V1H30 1000 L CN -** PC Z

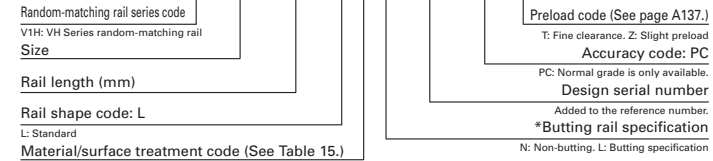

*Please consult with NSK for butting rail specification.

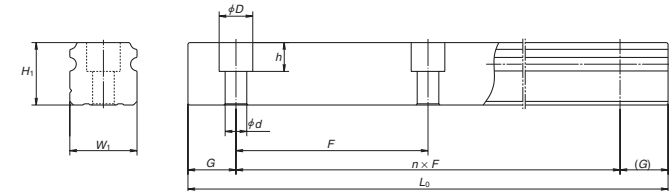

Unit: mm

Pitch	Rail		G	Max. length L_Dmax (mm) for stainless	Basic load rating				Weight					
	Mounting bolt hole	Tapped hole			Dynamic		Static	Static moment (N-m)		Ball slide (kg)	Rail (kg/m)			
					[50km]	[100km]		M_P0	M_Y0					
60	7x11x9	M6x1x12	20	3 960 [3 500]	33 500 45 500	26 800 36 500	46 000 71 000	360 555	320 725	1 840 3 700	267 610	1 540 3 100	0.46 0.69	3.6
80	9x14x12	M8x1.25x15	20	4 000 [3 500]	41 000 61 000	32 500 48 500	51 500 91 500	490 870	350 1 030	2 290 5 600	292 865	1 920 4 700	0.69 1.16	
80	9x14x12	M8x1.25x17	20	4 000	62 500 81 000	49 500 64 500	80 500 117 000	950 1 380	755 1 530	4 500 8 350	630 1 280	3 800 7 000	1.2 1.7	7.2
105	14x20x17	M12x1.75x24	22.5	3 990	107 000 131 000	84 500 104 000	140 000 187 000	2 140 2 860	1 740 3 000	9 750 15 600	1 460 2 520	8 150 13 100	2.2 2.9	
120	16x23x20	M14x2x24	30	3 960	158 000 193 000	125 000 153 000	198 000 264 000	3 600 4 850	3 000 5 150	16 300 26 300	2 510 4 350	13 700 22 100	3.7 4.7	16.9

4) The basic load rating comply with the ISO standard. (ISO 14728-1, 14728-2)

C_50: the basic dynamic load rating for 50 km rated fatigue life C_100: the basic dynamic load rating for 100 km rated fatigue life The basic static load rating shows static permissible load.

VH-EM (High-load type / Standard)
VH-GM (Super-high-load type / Long)

VH 30 1000 EM C 2 -** KC Z

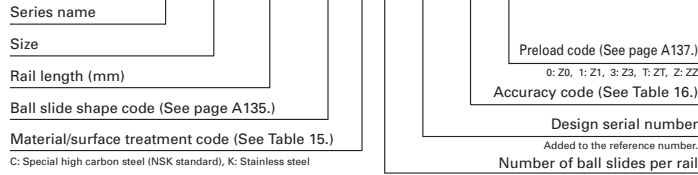

Front view of EM and GM type

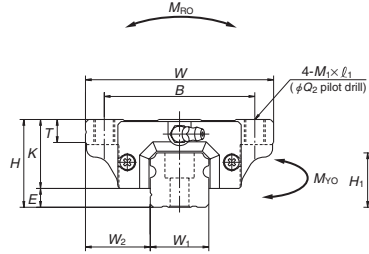

Side view of EM type

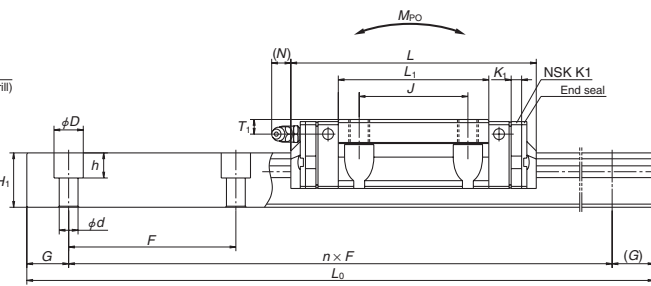

Specification for tapped holes on a rail bottom face

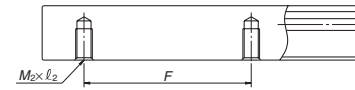

Side view of GM type

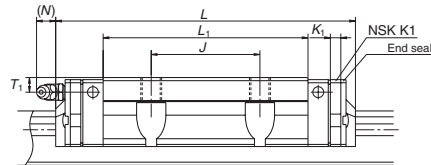

Model No.	Assembly		Ball slide													Width	Height		
	Height	Width	Length	Mounting hole						Grease fitting									
				B	J	Q ₁ × l ₁	Q ₂	L ₁	K	T	K ₁	Hole size	T ₁	N					
VH15EM	24	4.6	16	47	70.6 (77)	38	30	M5×0.8×7	4.4	39	19.4	8	4.5	φ3	4.5	1 (8.2)	15	15	
VH15GM					89.6 (96)					58									
VH20EM	30	5	21.5	63	87.4 (94.2)	53	40	M6×1×9.5	5.3	50	25	10	4.5	M6×0.75	5	11.1 (12.3)	20	18	
VH20GM					109.4 (116.2)					72									
VH25EM	36	7	23.5	70	97 (104.4)	57	45	M8×1.25×10	6.8	58	29	11	5	M6×0.75	6	9.6 (12.9)	23	22	
VH25GM					125 (132.4)			[M8×1.25×11.5]		86		[12]							
VH30EM	42	9	31	90	117.4 (127.8)	72	52	M10×1.5×12	8.6	72	33	11	5	M6×0.75	7	11.4 (14.2)	28	26	
VH30GM					143.4 (153.8)			[M10×1.5×14.5]		98		[15]							
VH35EM	48	9.5	33	100	128.8 (139.2)	82	62	M10×1.5×13	8.6	80	38.5	12	5.5	M6×0.75	8	10.9 (13.7)	34	29	
VH35GM					162.8 (173.2)					114									
VH45EM	60	14	37.5	120	161.4 (174.2)	100	80	M12×1.75×15	10.5	105	46	13	6.5	Rc1/8	10	12.5 (14.1)	45	38	
VH45GM					193.4 (206.2)					137									
VH55EM	70	15	43.5	140	185.4 (198.2)	116	95	M14×2×18	12.5	126	55	15	6.5	Rc1/8	11	12.5 (14.1)	53	44	
VH55GM					223.4 (236.2)					164									

- Notes: 1) Figure inside () is the dimension when equipped with the protector.
2) Figure inside [] is applied to stainless products.
3) VH Series does not have a ball retainer. Be aware that balls fall out when the ball slide is withdrawn from the rail.
4) External appearance of stainless steel ball slides differs from those of carbon steel ball slides.

Reference number for ball slide of random-matching type

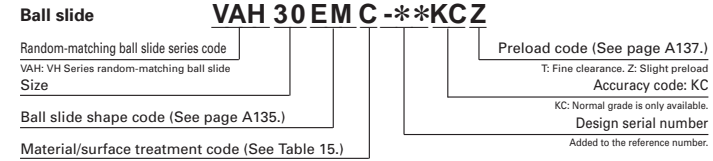

EM and GM types

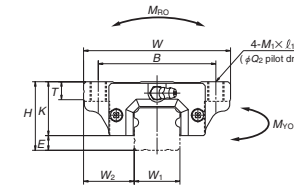

EM type

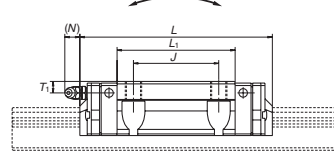

GM type

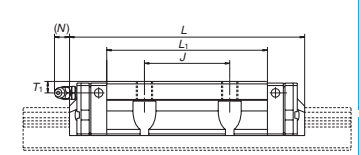

Reference number for rail of random-matching type

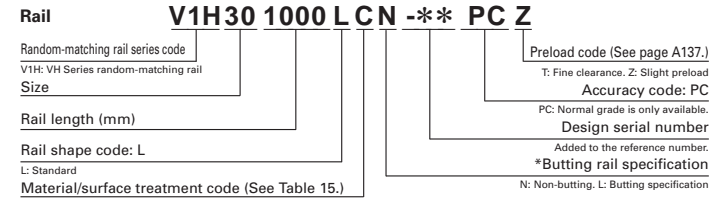

*Please consult with NSK for butting rail specification.

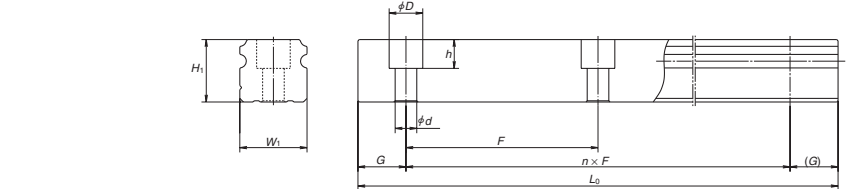

Unit: mm

Rail				Basic load rating						Weight				
Pitch	Mounting bolt hole	Tapped hole	G	Max. length L _{0max} () for stainless	Dynamic		Static	Static moment (N-m)				Ball slide (kg)	Rail (kg/m)	
					[50km]	[100km]		C ₀	M _{RO}	M _{PO}				M _{VO}
60	4.5×7.5×5.3	M5×0.8×8	20	2 000 [1 800]	14 200	11 300	20 700	108	94.5	575	79.5	480	0.17	1.6
					18 100	14 400	32 000	166	216	1 150	181	965	0.25	
60	6×9.5×8.5	M6×1×10	20	3 960 [3 500]	23 700	18 800	32 500	219	185	1 140	155	955	0.45	2.6
					30 000	24 000	50 500	340	420	2 230	355	1 870	0.65	
60	7×11×9	M6×1×12	20	3 960 [3 500]	33 500	26 800	46 000	360	320	1 840	267	1 540	0.63	3.6
					45 500	36 500	71 000	555	725	3 700	610	3 100	0.93	
80	9×14×12	M8×1.25×15	20	4 000 [3 500]	47 000	37 500	63 000	600	505	3 150	425	2 650	1.2	5.2
					61 000	48 500	91 500	870	1 030	5 600	865	4 700	1.6	
80	9×14×12	M8×1.25×17	20	4 000	62 500	49 500	80 500	950	755	4 500	630	3 800	1.7	7.2
					81 000	64 500	117 000	1 380	1 530	8 350	1 280	7 000	2.4	
105	14×20×17	M12×1.75×24	22.5	3 990	107 000	84 500	140 000	2 140	1 740	9 750	1 460	8 150	3.0	12.3
					131 000	104 000	187 000	2 860	3 000	15 600	2 520	13 100	3.9	
120	16×23×20	M14×2×24	30	3 960	158 000	125 000	198 000	3 600	3 000	16 300	2 510	13 700	5.0	16.9
					193 000	153 000	264 000	4 850	5 150	26 300	4 350	22 100	6.5	

- 5) The basic load rating comply with the ISO standard. (ISO 14728-1, 14728-2)
C₅₀: the basic dynamic load rating for 50 km rated fatigue life C₁₀₀: the basic dynamic load rating for 100 km rated fatigue life
The basic static load rating shows static permissible load.

NSK Data Sheet for Linear Guides in Contaminated Environments

[Example]

(Please copy) 1/1

Model: Graphite milling machine Location: Table axis

1. Operating Conditions

Operating Conditions	a) Ball or Roller slide motion b) Rail motion	Mounting Orientation	a) Vertical b) Horizontal c) Wall d) Upside-down e) Inclined f) Other
Stroke in Normal Use	<u>200</u> [mm] (Please indicate operating pattern)		
Lubricant	a) Grease (Brand: <u>NSK AS2 grease</u>) b) Oil (Brand:)	Lubricating Method	a) Automatic b) Grease gun (cm ³ / min)
Operating Duration	<u>2</u> years months		

2. Linear Guide Environment (Accessories & Contamination)

Contaminant	<u>Graphite powder</u>	Contaminant Size	Particle size <u>20 - 60μm</u>
Cause of Contamination	<u>Falls evenly on the rail surface.</u> (Please reference with photographs)		
Countermeasures (For already assembled parts, complete after inspection)	a) Telescopic cover b) Bellow c) Dust collector d) Dust-resistant lubricant e) Other () (Please supply drawings to demonstrate dust countermeasures)		

3. Linear Guide Dimensions

Model	<u>VH25AN</u>	Rail Length	<u>540</u> mm	No. of Slides/Rail	<u>2</u>	Accuracy Grade	<u>P6</u>
Preload	<u>Z1</u>	Max. Speed	<u>20</u> mm/sec	Dust-Proof Accessories	a) Double seal b) Mounting hole cap c) Protector d) Bellow		

Remarks

4. Durability Test

Durability test → Scheduled
→ Not scheduled (Reason:)

Linear Guide Use in Contaminated Environments

※Please read the below and tick the relevant boxes

- An evaluation test result of the special dust-resistant seal which NSK carried out is one case by a particular examination condition (alien substance environment and operating conditions). I accept that the special dust-resistant seal is unable to completely prevent contamination in such an environment and that life may be affected.
- In order to improve wear life in contaminated environments, NSK require **dust-proof accessories (covers, lubricating oil, dust collectors, etc)** in addition to the recommended seal exchange.
- Linear guide wear life is greatly impacted by contamination entering the slide, offset load from misalignment, as well as lubricating condition. **The final durability comes to need the evaluation confirmation with the actual machine.**

Company Name:	Date:	NSK Ltd. Sales Representative	NSK Ltd. Sales Manager
Department:	Name:	Sign	Sign
Address:	Tel:	Fax:	

NSK Data Sheet for Linear Guides in Contaminated Environments

(Please copy) 1/1

Model: _____ Location: _____

1. Operating Conditions

Operating Conditions	a) Ball or Roller slide motion b) Rail motion	Mounting Orientation	a) Vertical b) Horizontal c) Wall d) Upside-down e) Inclined f) Other
Stroke in Normal Use	[mm] (Please indicate operating pattern)		
Lubricant	a) Grease (Brand:) b) Oil (Brand:)	Lubricating Method	a) Automatic b) Grease gun (cm ³ / min)
Operating Duration	years months		

2. Linear Guide Environment (Accessories & Contamination)

Contaminant		Contaminant Size	Particle size -
Cause of Contamination	(Please reference with photographs)		
Countermeasures (For already assembled parts, complete after inspection)	a) Telescopic cover b) Bellow c) Dust collector d) Dust-resistant lubricant e) Other () (Please supply drawings to demonstrate dust countermeasures)		

3. Linear Guide Dimensions

Model		Rail Length	mm	No. of Slides/Rail		Accuracy Grade	
Preload		Max. Speed	mm/sec	Dust-Proof Accessories	a) Double seal b) Mounting hole cap c) Protector d) Bellow		

Remarks

4. Durability Test

Durability test → Scheduled
→ Not scheduled (Reason:)

Linear Guide Use in Contaminated Environments

※Please read the below and tick the relevant boxes

- An evaluation test result of the special dust-resistant seal which NSK carried out is one case by a particular examination condition (alien substance environment and operating conditions). I accept that the special dust-resistant seal is unable to completely prevent contamination in such an environment and that life may be affected.
- In order to improve wear life in contaminated environments, NSK require **dust-proof accessories (covers, lubricating oil, dust collectors, etc)** in addition to the recommended seal exchange.
- Linear guide wear life is greatly impacted by contamination entering the slide, offset load from misalignment, as well as lubricating condition. **The final durability comes to need the evaluation confirmation with the actual machine.**

Company Name:	Date:	NSK Ltd. Sales Representative	NSK Ltd. Sales Manager
Department:	Name:	Sign	Sign
Address:	Tel:	Fax:	

A-5-1.3 NS Series

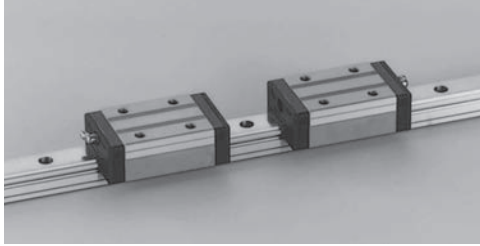

1. Features

(1) Improve rating life dramatically

Based on the LS series characterized by reliability and performance, a significant increase in durability has been attained. New ball groove geometry is introduced, which has been developed by utilizing NSK's state-of-the-art tribological and analytical technologies. Due to the optimized distribution of contact surface pressures, the rating life has dramatically increased.

As compared with the LS Series, the load rating capacity of the NS series has increased to 1.3 times, while the life span has increased to twice^{*1}. These features enable you to design a machine with a longer life and downsize the machine. Thus, your design capability is greatly enhanced.

^{*1}: Representative values of series.

(2) Ball circulation path with excellent high-speed property

By reexamining the design practice for the ball circulation path, we have attained smooth ball circulation and reduced noise level. So, NS series is suited for high-speed applications compared with the LS Series.

(3) All mounting dimensions are the same as those for the LS and SS Series

Regarding the mounting dimensions (mounting parts' dimensions), such as the mounting height, mounting width, mounting hole diameter/pitch of the linear guide, etc., the mounting dimensions of the NS Series remain the same as those of the conventional LS series and SS series. So, the new NS Series linear guides can be used without making any design changes.

(4) High self aligning capability (rolling direction)

Same as the DF combination in angular contact bearings, self-aligning capability is high because the cross point of the contact lines of balls and grooves comes inside, and thus reducing moment rigidity. This increases the capacity to absorb errors in installation.

(5) High load carrying capacity to vertical direction

The contact angle is set at 50 degrees, and thus increasing load carrying capacity as well as rigidity against the load in vertical direction.

(6) High resistance against impact load

The bottom ball groove is formed in Gothic arch and the center of the top and bottom grooves are offset as shown in Fig. 2. The vertical load is usually carried by top 2 rows, where balls are contacting at two points. Because of this design, the bottom rows will carry the load when a large impact load is applied as shown in Fig. 3. This assures high resistance to the impact load.

(7) High accuracy

As showing in Fig. 4, fixing the measuring rollers to the ball grooves is simple thanks to the Gothic arch groove. This makes easy and accurate measuring of ball grooves.

(8) Easy to handle, and designed with safety in mind.

Balls are retained in the retainer and do not fall out when the ball slide is withdrawn from the rail.

(9) Abundant models and sizes come in series.

Each size of NS Series has several ball slide models, rendering the linear guide available for numerous uses. The NS Series also has standardized long stainless- steel rail (maximum 3 500 mm).

(10) Fast delivery

Lineup of random-matching rails and ball slides supports and facilitates fast delivery.

High precision grade and medium preload types are also available in random matching. (Special high-carbon steel products)

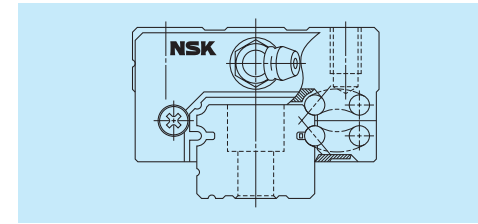

Fig. 1 NS Series

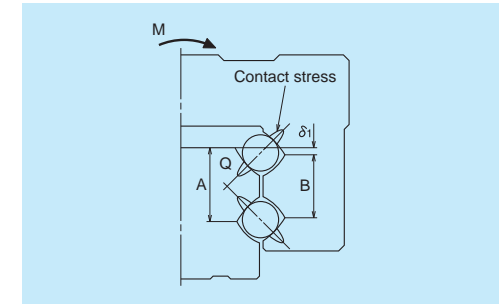

Fig. 2 Enlarged illustration of the offset Gothic arch groove

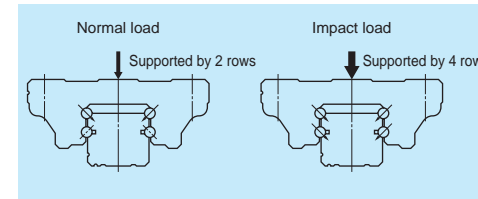

Fig. 3 When load is applied

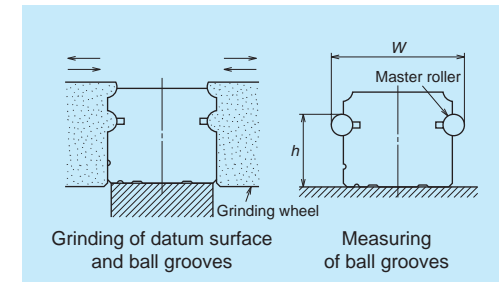

Fig. 4 Rail-grinding and measuring

2. Ball slide shape

Ball slide Model	Shape/installation method	Type (Upper row, Rating: Lower row, Ball slide length)	
		Medium-load type	High-load type
		Standard	Long
AL CL		CL 	AL
EM JM		JM 	EM

Note: High-precision grade and medium preload of random-matching type are not applicable to EL, JL, FL and KL models.

Note: For customers who have used the former LS or SS series, NS series is recommended as a substitute. Please confirm the correlation between NS series and former ones on the comparative table at A319.

3. Accuracy and preload

(1) Running parallelism of ball slide

Table 1

Unit: μm

Rail length (mm) over or less	Preloaded assembly (not random matching)					Random-matching type	
	Ultra precision P3	Super precision P4	High precision P5	Precision grade P6	Normal grade PN	High precision PH	Normal grade PC
– 50	2	2	2	4.5	6	2	6
50 – 80	2	2	3	5	6	3	6
80 – 125	2	2	3.5	5.5	6.5	3.5	6.5
125 – 200	2	2	4	6	7	4	7
200 – 250	2	2.5	5	7	8	5	8
250 – 315	2	2.5	5	8	9	5	9
315 – 400	2	3	6	9	11	6	11
400 – 500	2	3	6	10	12	6	12
500 – 630	2	3.5	7	12	14	7	14
630 – 800	2	4.5	8	14	16	8	16
800 – 1 000	2.5	5	9	16	18	9	18
1 000 – 1 250	3	6	10	17	20	10	20
1 250 – 1 600	4	7	11	19	23	11	23
1 600 – 2 000	4.5	8	13	21	26	13	26
2 000 – 2 500	5	10	15	22	29	15	29
2 500 – 3 150	6	11	17	25	32	17	32
3 150 – 4 000	9	16	23	30	34	23	34

(2) Accuracy standard

The preloaded assembly has five accuracy grades; Ultra precision P3, Super precision P4, High precision P5, Precision P6 and Normal PN grades, while the random-matching type has High-precision PH and Normal PC grade.

• Tolerance of preloaded assembly

Table 2

Unit: μm

Characteristics	Accuracy grade	Ultra precision P3	Super precision P4	High precision P5	Precision grade P6	Normal grade PN
Mounting height H Variation of H (All ball slides on a set of rails)		± 10 3	± 10 5	± 20 7	± 40 15	± 80 25
Mounting width W_2 or W_3 Variation of W_2 or W_3 (All ball slides on reference rail)		± 15 3	± 15 7	± 25 10	± 50 20	± 100 30
Running parallelism of surface C to surface A Running parallelism of surface D to surface B		See Table 1, Fig. 5 and Fig. 6				

• Tolerance of random-matching type

Table 3

Unit: μm

Characteristics	Model No.	High precision grade PH	Normal grade PC
Mounting height H		± 20	± 20
Variation of mounting height H		15① 30②	15① 30②
Mounting width W_2 or W_3		± 30	± 30
Variation of mounting width W_2 or W_3		20	25
Running parallelism of surface C to surface A Running parallelism of surface D to surface B		See Table 1, Fig. 5 and Fig. 6	

Notes: ① Variation on the same rail
② Variation on multiple rails

(3) Combinations of accuracy and preload

Table 4

	Accuracy grade							
	Ultra precision	Super precision	High precision	Precision grade	Normal grade	High precision	Normal grade	
Without NSK K1 lubrication unit	P3	P4	P5	P6	PN	PH	PC	
With NSK K1 lubrication unit	K3	K4	K5	K6	KN	KH	KC	
With NSK K1 for food and medical equipment	F3	F4	F5	F6	FN	FH	FC	
Preload	Fine clearance Z0	○	○	○	○	○	—	—
	Slight preload Z1	○	○	○	○	○	—	—
	Medium preload Z3	○	○	○	○	—	—	—
	Random-matching type with fine clearance ZT	—	—	—	—	—	—	○
	Random-matching type with slight preload ZZ	—	—	—	—	—	○	○
	Random-matching type with medium preload ZH	—	—	—	—	—	○	○

(4) Assembled accuracy

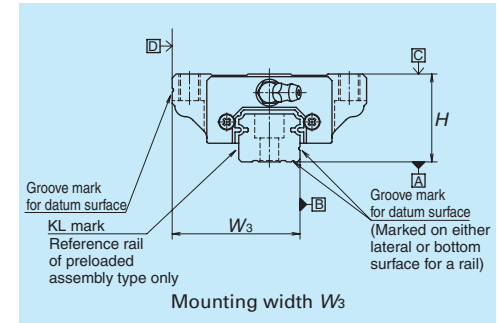
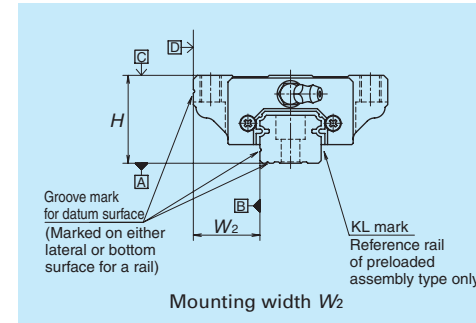

Fig. 5 Special high carbon steel

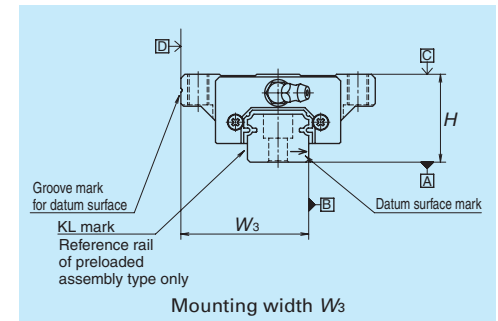
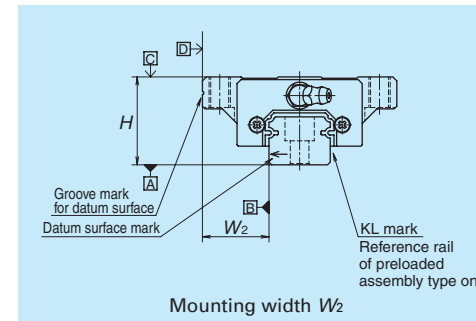

Fig. 6 Stainless steel

(5) Preload and rigidity

We offer six levels of preload: Slight preload Z1, Medium preload Z3 and Fine clearance Z0, along with random-matching type of Medium preload ZH, Fine clearance ZT and Slight preload ZZ.

• Preload and rigidity of preloaded assembly

Table 5

Model No.	Preload (N)		Rigidity (N/μm)				
	Slight preload Z1	Medium preload Z3	Vertical direction		Lateral direction		
			Slight preload Z1	Medium preload Z3	Slight preload Z1	Medium preload Z3	
High-load type	NS15 AL, EM	69	390	127	226	88	167
	NS20 AL, EM	88	540	147	284	108	206
	NS25 AL, EM	147	880	206	370	147	275
	NS30 AL, EM	245	1 370	255	460	186	345
	NS35 AL, EM	345	1 960	305	550	216	400
Medium-load type	NS15 CL, JM	49	294	78	147	59	108
	NS20 CL, JM	69	390	108	186	78	137
	NS25 CL, JM	98	635	127	235	88	177
	NS30 CL, JM	147	980	147	275	108	206
	NS35 CL, JM	245	1 370	186	335	137	245

Note: Clearance for Fine clearance Z0 is 0 to 3μm. Therefore, preload is zero. However, Z0 of PN grade is 0 to 15μm.

• Clearance and preload of random-matching type

Table 6

Model No.	Unit: μm		
	Fine clearance ZT	Slight preload ZZ	Medium preload ZH
NS15	-4 — 15	-4 — 0	-7 — -3
NS20	-4 — 15	-4 — 0	-7 — -3
NS25	-5 — 15	-5 — 0	-9 — -4
NS30	-5 — 15	-5 — 0	-9 — -4
NS35	-5 — 15	-6 — 0	-10 — -4

Note: Minus sign denotes that a value is an amount of preload (elastic deformation of balls).

4. Maximum rail length

Table 7 shows the limitations of rail length (maximum length). However, the limitations vary by accuracy grade.

Table 7 Length limitations of rails

Series	Size	Unit: mm				
		Material	15	20	25	30
NS	Special high carbon steel	2 920	3 960	3 960	4 000	4 000
	Stainless steel	1 800	3 500	3 500	3 500	3 500

Note: Rails can be butted if user requirement exceeds the rail length shown in the table. Please consult NSK.

5. Installation

(1) Permissible values of mounting error

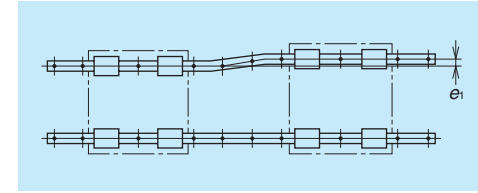

Fig. 7

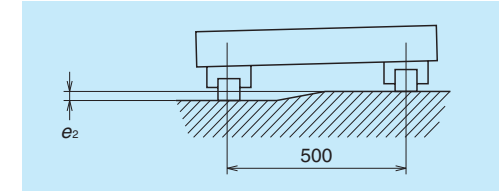

Fig. 8

Table 8

Value	Preload	Model No.				
		NS15	NS20	NS25	NS30	NS35
Permissible values of parallelism in two rails e_1	Z0, ZT	20	22	30	35	40
	Z1, ZZ	15	17	20	25	30
	Z3, ZH	12	15	15	20	25
Permissible values of parallelism (height) in two rails e_2	Z0, ZT	375 μm/500 mm				
	Z1, ZZ, Z3, ZH	330 μm/500 mm				

Unit: μm

(2) Shoulder height of the mounting surface and corner radius r

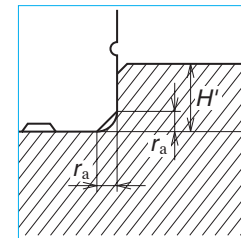

Fig. 9 Shoulder for the rail datum surface

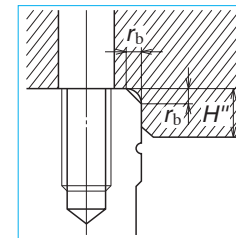

Fig. 10 Shoulder for the ball slide datum surface

Table 9

Model No.	Corner radius (maximum)		Shoulder height	
	r_a	r_b	H'	H''
NS15	0.5	0.5	4	4
NS20	0.5	0.5	4.5	5
NS25	0.5	0.5	5	5
NS30	0.5	0.5	6	6
NS35	0.5	0.5	6	6

Unit: mm

6. Maximum allowable speed

An indication of the standard maximum allowable speed aiming at 10,000km operation with NS series under normal conditions is shown in Table 10. However, the maximum allowable speed can be affected by accuracy of installation, operating temperature, external load, etc. If the operation is made exceeding the permissible distance and speed, please consult NSK.

Table 10 Maximum allowable speed Unit: m/min

Series	Size	15	20	25	30	35
NS		300				

7. Lubrication components

Refer to pages A38 and D13 for the lubrication of linear guides.

(1) Types of lubrication accessories

Fig. 11 and Table 11 show grease fittings and tube fittings.

We provide lubrication accessories with extended thread body length (L) for the addition of dust-proof accessories such as NSK K1 lubrication unit, double seal and protector.

We provide a suitable lubrication accessory for the special requirement on dust-proof accessories.

Consult NSK for a lubrication accessory with extended length of thread body for your convenience of replenishing lubricant.

When you require stainless lubrication accessories, please ask NSK.

(2) Mounting position of lubrication accessories

The standard position of grease fittings is the end face of ball slide. We mount them on a side of end cap for an option. (Fig. 12)

Please consult NSK for installation of grease or tube fittings to the ball slide body or side of end cap.

When using a piping unit with thread of M6 × 1, you require a connector to connect to a grease fitting mounting hole with M6 × 0.75. The connector is available from NSK.

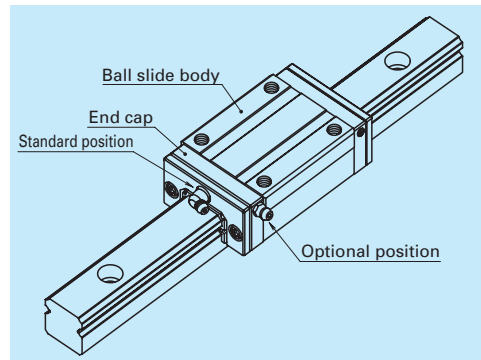

Fig. 12 Mounting position of lubrication accessories

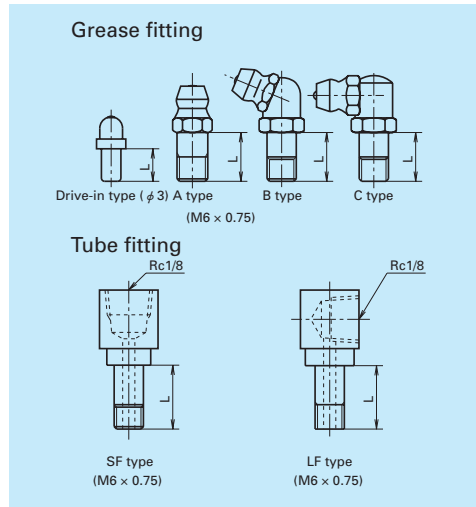

Fig. 11 Grease fitting and tube fitting

Model No.	Dust-proof specification	Dimension L		
		Grease fitting / Drive-in type	SF type	LF type
NS15	Standard	5	-	-
	With NSK K1	10	-	-
	Double seal	*	-	-
	Protector	*	-	-
NS20	Standard	5	-	-
	With NSK K1	10	-	-
	Double seal	8	-	-
	Protector	8	-	-
NS25	Standard	5	6	6
	With NSK K1	12	11	11
	Double seal	10	9	9
	Protector	10	9	9
NS30	Standard	5	6	6
	With NSK K1	14	12	13
	Double seal	12	10	11
	Protector	12	10	11
NS35	Standard	5	6	6
	With NSK K1	14	12	13
	Double seal	12	10	11
	Protector	12	10	11

*) A connector is required for this model. Please contact NSK.

8. Dust-proof components

(1) Standard specification

The NS Series can be readily used as they have a dust protection means for normal conditions. As the standard equipment, the ball slides have an end seal on both ends, and bottom seals at the bottom.

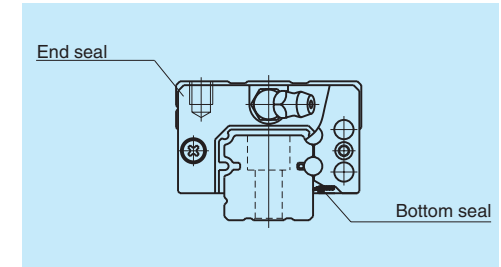

Fig. 13

Table 12 Seal friction per ball slide (maximum value)

Series	Size	Unit: N				
		15	20	25	30	35
NS		8	9	9	9	10

(2) NSK K1™ lubrication unit

Table 13 shows the dimension of linear guides equipped with the NSK K1 lubrication unit.

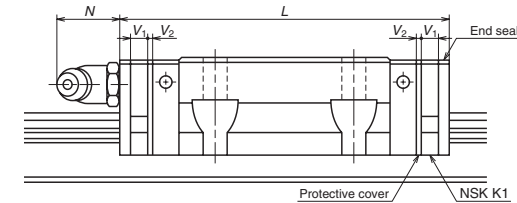

Table 13

Model No.	Ball slide length	Ball slide model	Standard ball slide length	Ball slide length installed with two NSK K1 L	Unit: mm		Protruding area of the grease fitting N
					Per NSK K1 thickness V ₁	Protective cover thickness V ₂	
NS15	Standard	AL, EM	56.8	66.4	4.0	0.8	(5)
	Short	CL, JM	40.4	50			
NS20	Standard	AL, EM	65.2	75.8	4.5	0.8	(14)
	Short	CL, JM	47.2	57.8			
NS25	Standard	AL, EM	81.6	92.2	4.5	0.8	(14)
	Short	CL, JM	59.6	70.2			
NS30	Standard	AL, EM	96.4	108.4	5.0	1.0	(14)
	Short	CL, JM	67.4	79.4			
NS35	Standard	AL, EM	108	121	5.5	1.0	(14)
	Short	CL, JM	77	90			

Note: Ball slide length equipped with NSK K1 = (Standard ball slide length) + (Thickness of NSK K1, V₁ × Number of NSK K1) + (Thickness of the protective cover, V₂ × 2)

(3) Double seal

Use a double seal set as showing in **Table 14**, when installing an extra seal to completed standard products. (**Fig.14**)

When installing a grease fitting after the installation of double seals, a connector as showing **Fig.14** is required.

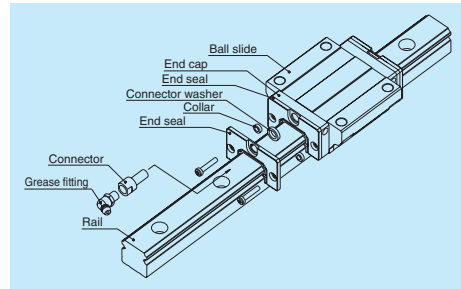

Fig. 14 Double seal

(4) Protector

Use a protector set as showing **Table 15**, when installing a protector to completed standard products. (**Fig.15**)

When installing a grease fitting after the installation of protectors, a connector as showing **Fig.15** is required.

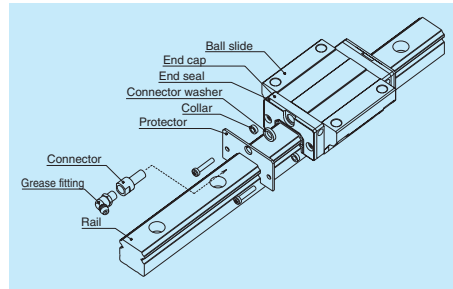

Fig. 15 Protector

Table 14 Double-seal set

Model No.	Reference No.		Increased thickness V_3 (mm)
	Without connector	With connector	
NS15	LS15WS-01	*	2.8
NS20	LS20WS-01	LS20WSC-01	2.5
NS25	LS25WS-01	LS25WSC-01	2.8
NS30	LS30WS-01	LS30WSC-01	3.6
NS35	LS35WS-01	LS35WSC-01	3.6

Table 15 Protector set

Model No.	Reference No.		Increased thickness V_4 (mm)
	Without connector	With connector	
NS15	LS15PT-01	*	3
NS20	LS20PT-01	LS20PTC-01	2.7
NS25	LS25PT-01	LS25PTC-01	3.2
NS30	LS30PT-01	LS30PTC-01	4.2
NS35	LS35PT-01	LS35PTC-01	4.2

*) For installation of a connector to a drive-in type grease fitting, contact NSK.

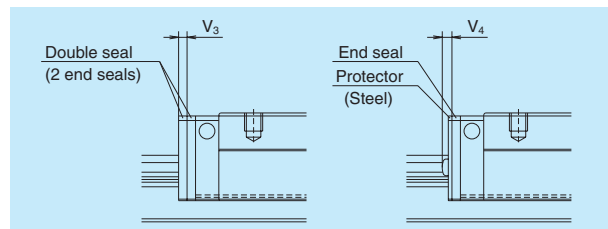

Fig. 16

(5) Cap to plug the rail mounting bolt hole

Table 16 Caps to plug rail bolt hole

Model No.	Bolt to secure rail	Cap reference No.	Quantity /case
NS15	M3	LG-CAP/M3	20
NS15	M4	LG-CAP/M4	20
NS20	M5	LG-CAP/M5	20
NS25, NS30	M6	LG-CAP/M6	20
NS35	M8	LG-CAP/M8	20

(7) Bellows

- A bellows fastener kit, which includes one of bellows faster, two of M_1 set screws, two of M_2 set screws, and two collars for M_2 set screws as showing Fig. 7.7 on page A55, is supplied with bellows for the ends.
- Middle bellows are supplied with four set screws and four collars.
- Use a bellows fastener kit as showing **Table 18**, when installing bellows to completed standard products.
- When NSK K1, double seals or protectors are used, the set screws of bellows fastener kit are unable to use. Please contact NSK for details.
- Bellows fastener is available only for the horizontal mounting positions. For other mounting positions, sliding plate is required (see **Fig. 7.10** on page A56).

For fixing to the rail, make tap holes to the rail end surface. Fix the bellows mounting plate to the rail end surface through these tap holes by using a machine screw. NSK processes a tap hole to the rail end face when ordered with a linear guide.

(6) Inner seal

Inner seal is only available for the models shown below.

Table 17

Series	Model No.
NS	NS20, NS25, NS30, NS35

Table 18 Bellows fastner kit reference No.

Model No.	Kit reference No.
NS15	LS15FS-01
NS20	LS20FS-01
NS25	LS25FS-01
NS30	LS30FS-01
NS35	LS35FS-01

Dimension tables of bellows
NS Series

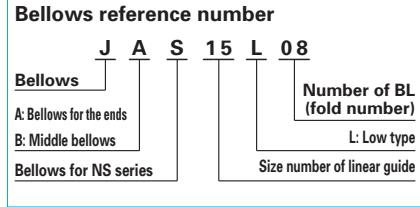
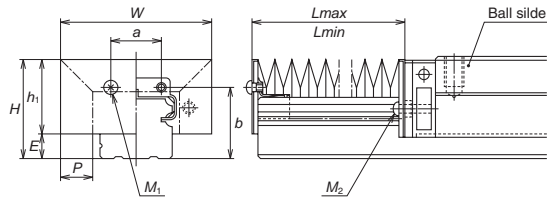

Fig. 17 Dimensions of bellows

Table 19 Dimensions of bellows

Unit: mm

Model No.	H	h ₁	E	W	P	a	b	BL minimum length	M ₁ Tap x depth	M ₂ Tap x depth
JAS15L	23.5	18.9	4.6	43	10	8	16.5	17	M3 × 5	M3 × 14
JAS20L	27	21	6	48	10	13	19.7	17	M3 × 5	M2.5 × 14
JAS25L	32	25	7	51	10	15	23.2	17	M3 × 5	M3 × 18
JAS30L	41	32	9	66	15	16	29	17	M4 × 6	M4 × 19
JAS35L	47	36.5	10.5	72	15	22	33.5	17	M4 × 6	M4 × 22

Table 20 Numbers of folds (BL) and lengths of bellows

Unit: mm

Model No.	Number of BL	2	4	6	8	10	12	14	16	18	20
		L _{min}	34	68	102	136	170	204	238	272	306
JAS15L	Stroke	106	212	318	424	530	636	742	848	954	1 060
	L _{max}	140	280	420	560	700	840	980	1 120	1 260	1 400
JAS20L	Stroke	106	212	318	424	530	636	742	848	954	1 060
	L _{max}	140	280	420	560	700	840	980	1 120	1 260	1 400
JAS25L	Stroke	106	212	318	424	530	636	742	848	954	1 060
	L _{max}	140	280	420	560	700	840	980	1 120	1 260	1 400
JAS30L	Stroke	176	352	528	704	880	1 056	1 232	1 408	1 584	1 760
	L _{max}	210	420	630	840	1 050	1 260	1 470	1 680	1 890	2 100
JAS35L	Stroke	176	352	528	704	880	1 056	1 232	1 408	1 584	1 760
	L _{max}	210	420	630	840	1 050	1 260	1 470	1 680	1 890	2 100

Note: The values of an odd number BL quantity (3, 5, 7, ...) can be obtained by adding two values of even number BL on the both side, then by dividing the sum by 2.

9. Reference number

Reference numbers shall be set to individual NSK linear guide when its specifications are finalized, and it is indicated on its specification drawing.
Please specify the reference number, except design serial number, to identify the product when ordering, requiring estimates, or inquiring about specifications from NSK.

(1) Reference number for preloaded assembly

NS 30 1200 AL C 2 - P5 3**

Series name	Preload code (See page A156.)
Size	0: Z0, 1: Z1, 3: Z3
Rail length (mm)	Accuracy code (See Table 22.)
Ball slide shape code (See page A154.)	Design serial number
Material/surface treatment code (See Table 21.) C: Special high carbon steel (NSK standard), K: Stainless steel	Added to the reference number. Number of ball slides per rail

(2) Reference number for random-matching type

Ball slide **NAS 30 AL SZ -K**

Random-matching ball slide series code NAS: NS Series random-matching ball slide	Option code -K: Equipped with NSK K1 -F: Fluoride low temperature chrome plating + AS2 grease -F50: Fluoride low temperature chrome plating + LG2 grease
Size	Preload code No code: Fine clearance, Z: Slight preload, H: Medium preload
Ball slide shape code (See page A154.)	Material code No code: Special high carbon steel (NSK standard), S: Stainless steel

Rail **N1S30 1200 L CN -** PC Z**

Random-matching rail series code N1S: NS Series random-matching rail	Preload code (See page A156.) T: Fine clearance, Z: Slight preload (common rail for slight or medium preload)
Size	Accuracy code PH: High precision grade random-matching type PC: Normal grade random-matching type
Rail length (mm)	Design serial number
Rail shape code L: Standard T: NS15 with mounting holes for M4	Added to the reference number. *Butting rail specification
Material/surface treatment code (See Table 21.)	N: Non-butting, L: Butting specification

*Please consult with NSK for butting rail specification.

The reference number coding for the assembly of random-matching type is the same as that of the preloaded assembly. However, only preload codes of "fine clearance T" and "slight preload Z" are available (refer to page A156).

Table 21 Material/surface treatment code

Code	Description
C	Special high carbon steel (NSK standard)
K	Stainless steel
D	Special high carbon steel with surface treatment
H	Stainless steel with surface treatment
Z	Other, special

Note: High-precision grade and medium preload of random-matching type are not available in stainless steel.

Table 22 Accuracy code

Accuracy	Standard (Without NSK K1)	With NSK K1	With NSK K1 for food and medical equipment
Ultra precision grade	P3	K3	F3
Super precision grade	P4	K4	F4
High precision grade	P5	K5	F5
Precision grade	P6	K6	F6
Normal grade	PN	KN	FN
High precision grade (random-matching type)	PH	KH	FH
Normal grade (random-matching type)	PC	KC	FC

Note: Refer to pages A38 and A61 for NSK K1 lubrication unit.

10. Dimensions
NS-CL (Medium-load type / Short)
NS-AL (High-load type / Standard)

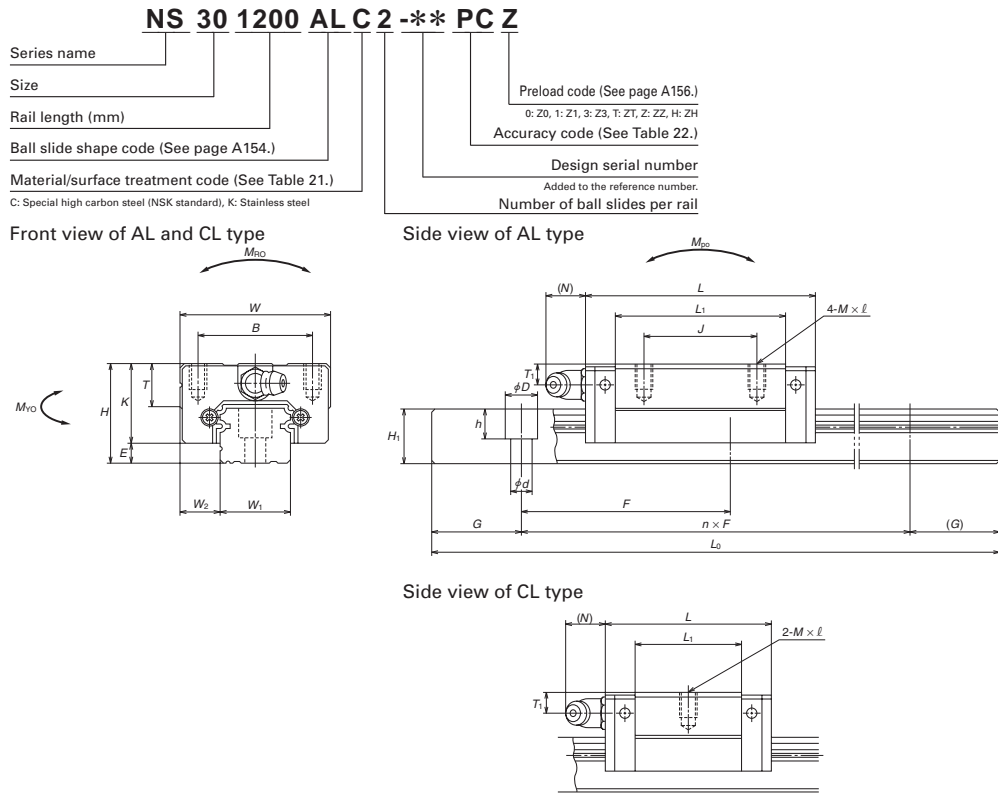

Model No.	Assembly			Ball slide											Width	Height
	Height	Width	Length	Mounting hole						Grease fitting						
				H	E	W ₂	W	L	B	J	M × pitch × l	L ₁	K	T		
NS15CL	24	4.6	9.5	34	40.4	26	—	M4×0.7×6	23.6	19.4	10	φ 3	6	3	15	12.5
NS15AL	24	4.6	9.5	34	56.8	26	—	M4×0.7×6	40	19.4	10	φ 3	6	3	15	12.5
NS20CL	28	6	11	42	47.2	32	—	M5×0.8×7	30	22	12	M6×0.75	5.5	11	20	15.5
NS20AL	28	6	11	42	65.2	32	—	M5×0.8×7	48	22	12	M6×0.75	5.5	11	20	15.5
NS25CL	33	7	12.5	48	59.6	35	—	M6×1×9	38	26	12	M6×0.75	7	11	23	18
NS25AL	33	7	12.5	48	81.6	35	—	M6×1×9	60	26	12	M6×0.75	7	11	23	18
NS30CL	42	9	16	60	67.4	40	—	M8×1.25×12	42	33	13	M6×0.75	8	11	28	23
NS30AL	42	9	16	60	96.4	40	—	M8×1.25×12	71	33	13	M6×0.75	8	11	28	23
NS35CL	48	10.5	18	70	77	50	—	M8×1.25×12	49	37.5	14	M6×0.75	8.5	11	34	27.5
NS35AL	48	10.5	18	70	108	50	—	M8×1.25×12	80	37.5	14	M6×0.75	8.5	11	34	27.5

Notes: 1) External appearance of stainless steel ball slides differs from those of carbon steel ball slides.

Reference number for ball slide of random-matching type

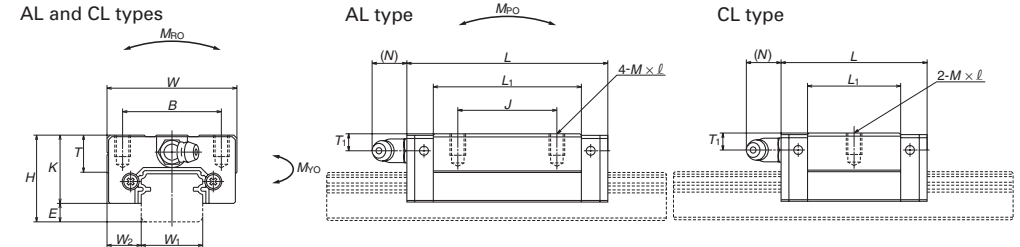
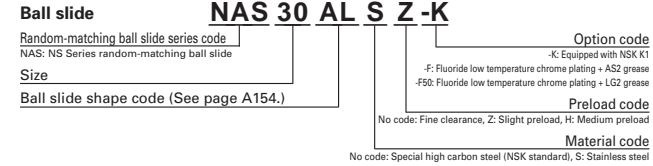

Reference number for rail of random-matching type

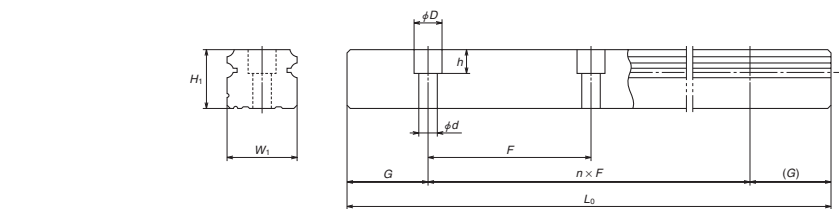
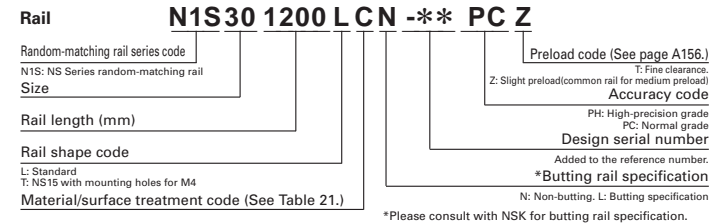

Unit: mm

Rail	Basic load rating											Weight					
	Pitch	Mounting bolt hole	G	Max. length L _{max} () for stainless	Dynamic		Static C ₀ (N)	Static moment (N-m)				Ball slide (kg)	Rail (kg/m)				
					[50km]	[100km]		M _{PO}	M _{VO}								
60	*3.5×6×4.5 4.5×7.5×5.3	20	7 250 (1 800)	9 100 (2 300)	5 750 (1 400)	11 200 (2 800)	8 850 (2 200)	9 100 (2 300)	45.5 (11.4)	24.5 (6.1)	196 (49.6)	470 (119)	20.5 (5.2)	165 (41.8)	0.14 (0.035)	1.4	
60	6×9.5×8.5	20	3 960 (3 500)	10 600 (2 650)	8 400 (2 100)	15 600 (3 900)	12 400 (3 100)	13 400 (3 350)	160 (40.5)	133 (33.2)	755 (189)	111 (27.9)	330 (83.5)	39 (9.8)	279 (70.2)	0.19 (0.048)	2.3
60	7×11×9	20	3 960 (3 500)	17 700 (4 425)	14 000 (3 500)	26 100 (6 525)	20 700 (5 175)	20 800 (5 200)	164 (41.5)	91 (22.8)	655 (164)	76 (19.1)	550 (139)	51 (12.9)	3.1	3.1	
80	7×11×9	20	4 000 (3 500)	24 700 (6 175)	19 600 (4 900)	38 000 (9 600)	30 000 (7 500)	29 600 (7 400)	282 (70.5)	139 (34.8)	1 080 (271)	116 (29.1)	2 650 (668)	365 (91.8)	905 (228)	0.58 (0.147)	4.8
80	9×14×12	20	4 000 (3 500)	34 500 (8 625)	27 300 (6 825)	40 000 (10 000)	27 300 (6 825)	40 000 (10 000)	465 (116)	220 (55.5)	1 670 (418)	185 (46.3)	2 650 (668)	365 (91.8)	1 400 (354)	0.86 (0.216)	7.0

2) The basic load rating comply with the ISO standard. (ISO 14728-1, 14728-2)
 C₅₀: the basic dynamic load rating for 50 km rated fatigue life C₁₀₀: the basic dynamic load rating for 100 km rated fatigue life
 The basic static load rating shows static permissible load.
 3) High-precision grade and medium preload of random-matching type are available for special high carbon steel products.
 * Standard mounting hole of NS15 rail is for M3 bolts (Hole size: 3.5 × 6 × 4.5).
 If you require mounting hole for M4 bolts (Hole size: 4.5 × 7.5 × 5.3), please specify when ordering.

NS-JM (Medium-load type / Short)
NS-EM (High-load type / Standard)

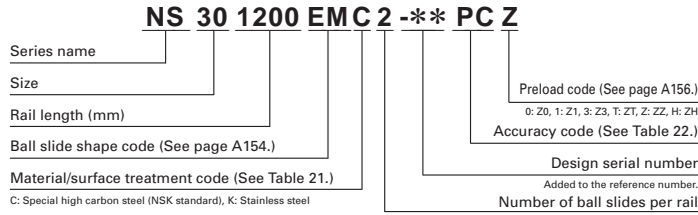

Front view of EM and JM type

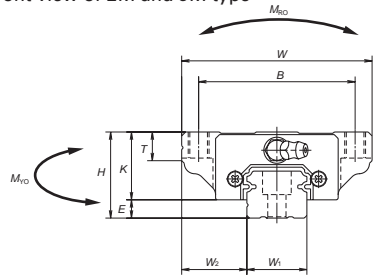

Side view of EM type

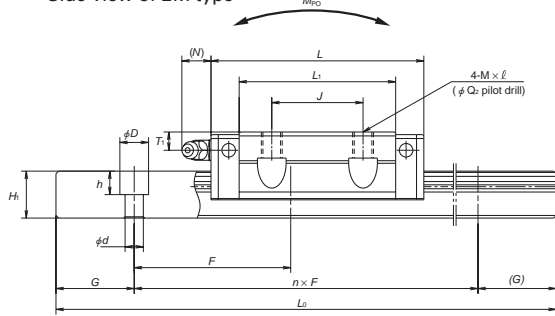

Side view of JM type

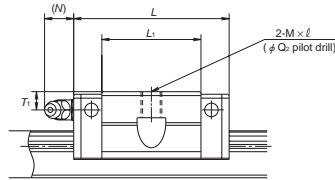

Reference number for ball slide of random-matching type

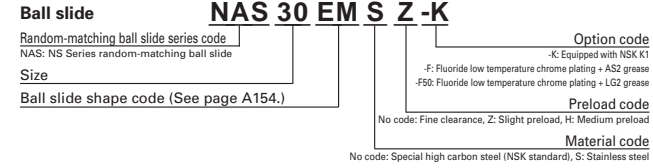

EM and JM types

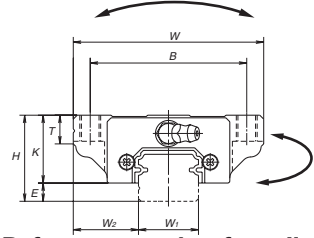

EM type

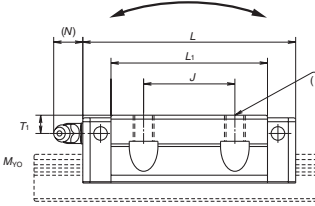

JM type

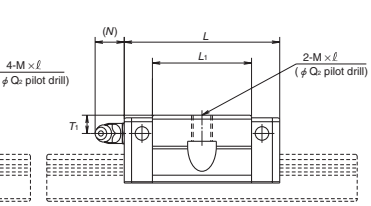

Reference number for rail of random-matching type

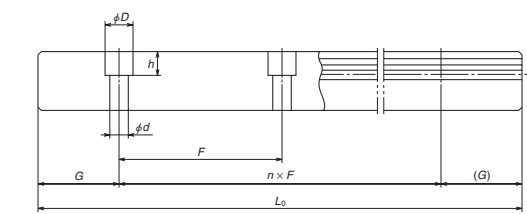
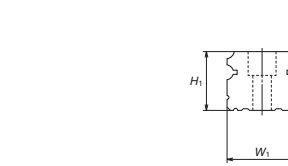
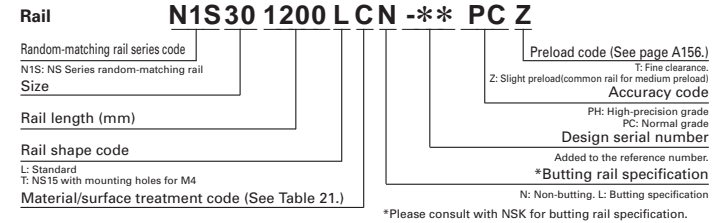

Model No.	Assembly			Ball slide											Width	Height	
	Height	E	W ₂	Width	Length	Mounting hole					Grease fitting			Width			Height
						B	J	M × pitch × l	Q ₂	L ₁	K	T	Hole size				
NS15JM NS15EM	24	4.6	18.5	52	40.4 56.8	41	— 26	M5×0.8×7	4.4	23.6 40	19.4	8	φ3	6	3	15	12.5
NS20JM NS20EM	28	6	19.5	59	47.2 65.2	49	— 32	M6×1×9 (M6×1×9.5)	5.3	30 48	22	10	M6×0.75	5.5	11	20	15.5
NS25JM NS25EM	33	7	25	73	59.6 81.6	60	— 35	M8×1.25×10 (M8×1.25×11.5)	6.8	38 60	26	11 (12)	M6×0.75	7	11	23	18
NS30JM NS30EM	42	9	31	90	67.4 96.4	72	— 40	M10×1.5×12 (M10×1.5×14.5)	8.6	42 71	33	11 (15)	M6×0.75	8	11	28	23
NS35JM NS35EM	48	10.5	33	100	77 108	82	— 50	M10×1.5×13 (M10×1.5×14.5)	8.6	49 80	37.5	12 (15)	M6×0.75	8.5	11	34	27.5

Notes: 1) External appearance of stainless steel ball slides differs from those of carbon steel ball slides.
 2) Parenthesized dimensions are for items made of stainless steel.

Unit: mm

Rail	Pitch	Mounting bolt hole	G	Max. length L _{dimax} () for stainless	Basic load rating						Weight		
					Dynamic		Static	Static moment (N·m)				Ball slide (kg)	Rail (kg/m)
					[50km]	[100km]		C ₀	M _{R0}	M _{P0}			
60	*3.5×6×4.5 4.5×7.5×5.3	20	7 250 (1 800)	5 750 8 850	9 100 16 900	45.5 84.5	24.5 77	196 470	20.5 64.5	165 395	0.17 0.26	1.4	
60	6×9.5×8.5	20	3 960 (3 500)	10 600 15 600	8 400 12 400	13 400 23 500	91.5 160	46.5 755	330 111	39 755	279 630	0.24 0.35	2.3
60	7×11×9	20	3 960 (3 500)	17 700 26 100	14 000 20 700	20 800 36 500	164 286	91 258	655 1 470	76 217	550 1 230	0.44 0.66	3.1
80	7×11×9	20	4 000 (3 500)	24 700 38 000	19 600 30 000	29 600 55 000	282 520	139 435	1 080 2 650	116 365	905 2 220	0.76 1.2	4.8
80	9×14×12	20	4 000 (3 500)	34 500 52 500	27 300 42 000	40 000 74 500	465 865	220 695	1 670 4 000	185 580	1 400 3 350	1.2 1.7	7

3) The basic load rating comply with the ISO standard. (ISO 14728-1, 14728-2)
 C₅₀: the basic dynamic load rating for 50 km rated fatigue life C₁₀₀: the basic dynamic load rating for 100 km rated fatigue life
 The basic static load rating shows static permissible load.
 4) High-precision grade and medium preload of random-matching type are available for special high carbon steel products.
 * Standard mounting hole of NS15 rail is for M3 bolts (Hole size: 3.5 × 6 × 4.5).
 If you require mounting hole for M4 bolts (Hole size: 4.5 × 7.5 × 5.3), please specify when ordering.

A-5-1.4 LW Series

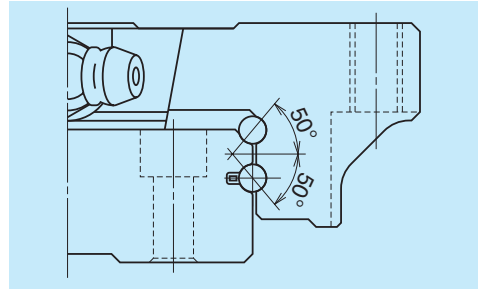
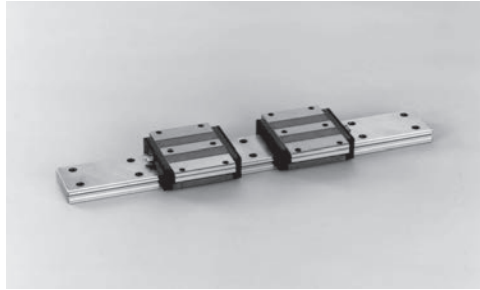

Fig. 1 Balls in contact

1. Features

(1) Ideal for use of single rail

Thanks to the wide rail, rigidity and load carrying capacity are high against moment load from rolling direction. This makes the LW Series ideal for a single rail, compact linear guideway system.

(2) High load carrying capacity to vertical direction

The contact angle is set at 50 degrees, increasing load carrying capacity as well as rigidity in vertical direction.

(3) High resistance against impact load

Same as the NH and NS series, the offset Gothic arch grooves support a large load, such as an impact, by four rows.

2. Ball slide shape

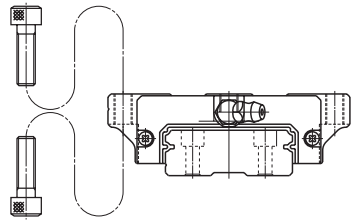
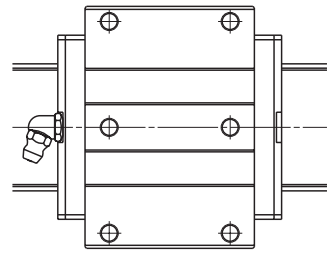
Ball slide Model	Shape / installation method	Type
EL		EL 

3. Accuracy and preload

(1) Running parallelism of ball slide

Table 1

Unit: μm

Rail length (mm) over or less	Preloaded assembly (not random matching)			Random-matching type
	High precision P5	Precision grade P6	Normal grade PN	Normal grade PC
– 50	2	4.5	6	6
50 – 80	3	5	6	6
80 – 125	3.5	5.5	6.5	6.5
125 – 200	4	6	7	7
200 – 250	5	7	8	8
250 – 315	5	8	9	9
315 – 400	6	9	11	11
400 – 500	6	10	12	12
500 – 630	7	12	14	14
630 – 800	8	14	16	16
800 – 1 000	9	16	18	18
1 000 – 1 250	10	17	20	20
1 250 – 1 600	11	19	23	23
1 600 – 2 000	13	21	26	26
2 000 – 2 500	15	22	29	29
2 500 – 3 150	17	25	32	32
3 150 – 4 000	23	30	34	34

(2) Accuracy standard

The preloaded assembly has three accuracy grades; High precision P5, Precision P6, and Normal PN grades, while the random-matching type has Normal PC grade only.

• Tolerance of preloaded assembly type

Table 2

Unit: μm

Characteristics	Accuracy grade	High precision P5	Precision grade P6	Normal grade PN
Mounting height H		± 20	± 40	± 80
Variation of H (All ball slides on a set of rails)		7	15	25
Mounting width W_2 or W_3		± 25	± 50	± 100
Variation of W_2 or W_3 (All ball slides on reference rail)		10	20	30
Running parallelism of surface C to surface A	Shown in Table 1 and Fig. 2			
Running parallelism of surface D to surface B	Shown in Table 1 and Fig. 2			

• Tolerance of random-matching type: Normal grade PC

Table 3

Unit: μm

Characteristics	Model No.	LW17, 21, 27, 35, 50
Mounting height H		± 20
Variation of mounting height H		15 ^① 30 ^②
Mounting width W_2 or W_3		± 30
Variation of mounting width W_2 or W_3		25
Running parallelism of surface C to surface A	See Table 1 and Fig. 2	
Running parallelism of surface D to surface B	See Table 1 and Fig. 2	

Note: ① Variation on the same rail

② Variation on multiple rails

(3) Combination of accuracy and preload

Table 4

	Accuracy grade				
	High precision	Precision grade	Normal grade	Normal grade	
Without NSK K1 lubrication unit	P5	P6	PN	PC	
With NSK K1 lubrication unit	K5	K6	KN	KC	
With NSK K1 for food and medical equipment	F5	F6	FN	FC	
Preload	Fine clearance Z0	○	○	○	—
	Slight preload Z1	○	○	○	—
	Medium preload Z3	○	○	—	—
	Random-matching type with fine clearance ZT	—	—	—	○
	Random-matching type with slight preload ZZ	—	—	—	○

Note: Z3 medium preload is only applicable to models of LW35 and LW50.

(4) Assembled accuracy

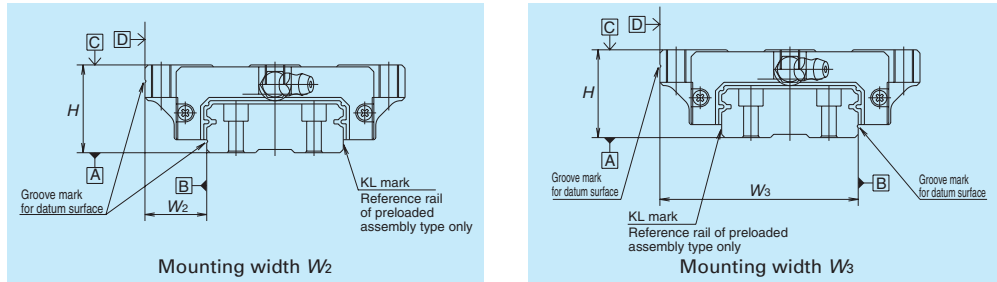

Fig. 2

(5) Preload and rigidity

We offer five levels of preload: Slight preload Z1, Medium preload Z3 and Fine clearance Z0, along with Random-matching type of Fine clearance ZT and Slight preload ZZ. Rigidities are for the median of the preload range.

• Preload and rigidity of preloaded assembly

Table 5

Model No.	Preload (N)		Rigidity (N/μm)			
	Slight preload Z1	Medium preload Z3	Vertical direction		Lateral direction	
			Slight preload Z1	Medium preload Z3	Slight preload Z1	Medium preload Z3
LW17 EL	0 – 245	—	156	—	112	—
LW21 EL	0 – 294	—	181	—	130	—
LW27 EL	0 – 390	—	226	—	167	—
LW35 EL	0 – 490	785	295	440	213	315
LW50 EL	0 – 590	1 470	345	600	246	425

Note: Clearance for Fine clearance Z0 is 0 to 3μm. Therefore, preload is zero. However, Z0 of PN grade is 0 to 15μm.

• Clearance and preload of random-matching type

Table 6

Unit: μm

Model No.	Fine clearance ZT	Slight preload ZZ
	LW17	-3 – 15
LW21	-3 – 15	-3.5 – 0
LW27	-4 – 15	-4 – 0
LW35	-5 – 15	-5 – 0
LW50	-5 – 15	-7 – 0

Note: Minus sign denotes elastic deformation of balls representing.

5. Installation

(1) Permissible values of mounting error

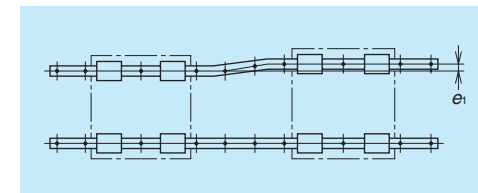

Fig. 3

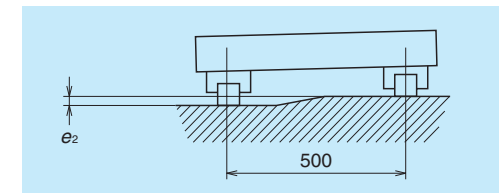

Fig. 4

Table 8

Unit: μm

Value	Preload	Model No.				
		LW17	LW21	LW27	LW35	LW50
Permissible values of parallelism in two rails e ₁	Z0, ZT	20	20	25	38	50
	Z1, ZZ	9	9	13	23	34
Permissible values of parallelism (height) in two rails e ₂	Z0, ZT	100 μm/500 mm				
	Z1, ZZ	45 μm/500 mm				

(2) Shoulder height of the mounting surface and corner radius r

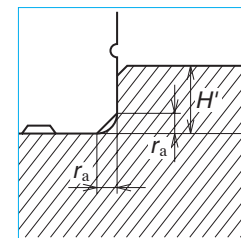

Fig. 5 Shoulder for the rail datum surface

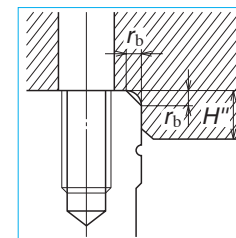

Fig. 6 Shoulder for the ball slide datum surface

Table 9

Unit: mm

Model No.	Corner radius (maximum)		Shoulder height	
	r _a	r _b	H'	H''
LW17	0.3	0.3	2.2	4
LW21	0.3	0.3	2.5	5
LW27	0.5	0.5	3.5	5
LW35	0.5	0.8	3.5	5
LW50	0.8	0.8	4	6

6. Lubrication components

Refer to pages A38 and D13 for the lubrication of linear guides.

(1) Types of lubrication accessories

Fig. 7 and Table 10 show grease fittings and tube fittings.

We provide lubrication accessories with extended thread body length (L) for the addition of dust-proof accessories such as NSK K1 lubrication unit, double seal and protector.

We provide a suitable lubrication accessory for the special requirement on dust-proof accessories.

Consult NSK for a lubrication accessory with extended length of thread body for your convenience of replenishing lubricant.

Please ask NSK for stainless lubrication accessories.

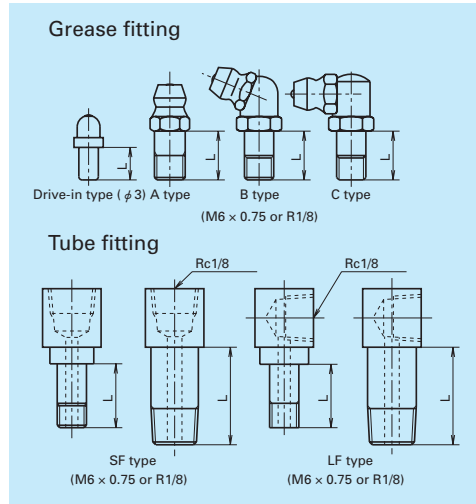

Fig. 7 Grease fitting and tube fitting

Table 10 Unit: mm

Model No.	Dust-proof specification	Dimension L		
		Grease fitting / Drive-in type	SF type	LF type
LW17	Standard	5	-	-
	With NSK K1	10	-	-
	Double seal	*	-	-
	Protector	*	-	-
LW21	Standard	5	-	-
	With NSK K1	12	-	-
	Double seal	10	-	-
	Protector	10	-	-
LW27	Standard	5	5	5
	With NSK K1	12	12	12
	Double seal	10	9	9
	Protector	10	9	9
LW35	Standard	5	6	6
	With NSK K1	14	14	13
	Double seal	10	10	9
	Protector	10	10	9
LW50	Standard	8	13.5	17
	With NSK K1	18	18	19
	Double seal	14	16	17
	Protector	14	13.5	17

*) A connector is required for the grease fitting. Please contact NSK.

(2) Mounting position of lubrication accessories

The standard position of grease fittings is the end face of ball slide. We may mount them on a side of end cap for LW27, 35, and 50 as an option. (Fig. 8)

Please consult NSK for installation of grease or tube fittings to the ball slide body or side of end cap.

When using a piping unit with thread of M6 × 1, you require a connector for a connection to a grease fitting mounting hole with M6 × 0.75. The connector is available from NSK.

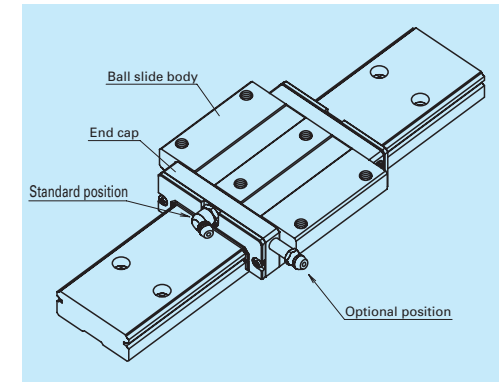

Fig. 8 Mounting position of lubrication accessories

7. Dust-proof components

(1) Standard Specification

The LW Series can be readily used as they have a dust protection means for normal conditions. As the standard equipment, the series has an end seal on both ends and bottom seals at the bottom.

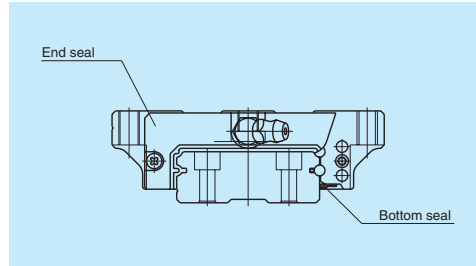

Fig. 9

Table 11 Seal friction per ball slide (maximum value) Unit: N

Series	Size	17	21	27	35	50
LW		6	8	12	16	20

(2) NSK K1™ lubrication unit

Table 12 shows the dimension of linear guides equipped with the NSK K1 lubrication unit.

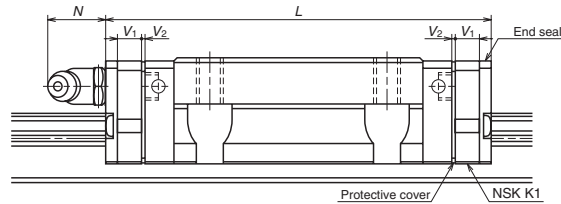

Table 12 Unit: mm

Model No.	Ball slide length	Ball slide model	Standard ball slide length	Ball slide length installed with two NSK K1 L	Per NSK K1 thickness V ₁	Protective cover thickness V ₂	Protruding area of the grease fitting N
LW17	Standard	EL	51.4	61.6	4.5	0.6	(5)
LW21	Standard	EL	58.8	71.4	5.5	0.8	(13)
LW27	Standard	EL	74	86.6	5.5	0.8	(13)
LW35	Standard	EL	108	123	6.5	1.0	(13)
LW50	Standard	EL	140.6	155.6	6.5	1.0	(14)

Note: 1) NSK K1 for food and medical equipments are available for the models of LW17 to LW35.
 2) Ball slide length equipped with NSK K1 = (Standard ball slide length) + (Thickness of NSK K1, V₁ x Number of NSK K1) + (Thickness of the protective cover, V₂ x 2)

(3) Double seal

Use a double seal set as showing in Table 13, when installing an extra seal to completed standard products. (Fig. 10)

When installing a grease fitting after the installation of double seals, a connector as showing Fig.10 is required.

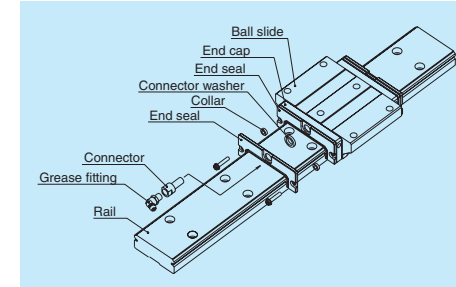

Fig. 10 Double seal

Table 13 Double-seal set

Model No.	Reference No.		Increased thickness V ₃ (mm)
	Without connector	With connector	
LW17	LW17WS-01	*	2.6
LW21	LW21WS-01	LW21WSC-01	2.8
LW27	LW27WS-01	LW27WSC-01	2.5
LW35	LW35WS-01	LW35WSC-01	3
LW50	LW50WS-01	LW50WSC-01	3.6

*) For installation of a connector to a drive-in type grease fitting, contact NSK.

(4) Protector

Use a protector set as showing Table 14, when installing a protector to completed standard products. (Fig.11)

When installing a grease fitting after the installation of protectors, a connector as showing Fig.11 is required.

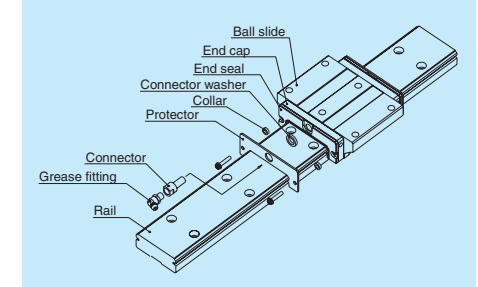

Fig. 11 Protector seal

Table 14 Protector set

Model No.	Reference No.		Increased thickness V ₄ (mm)
	Without connector	With connector	
LW17	LW17PT-01	*	3.2
LW21	LW21PT-01	LW21PTC-01	3.2
LW27	LW27PT-01	LW27PTC-01	2.9
LW35	LW35PT-01	LW35PTC-01	3.6
LW50	LW50PT-01	LW50PTC-01	4.2

*) For installation of a connector to a drive-in type grease fitting, contact NSK.

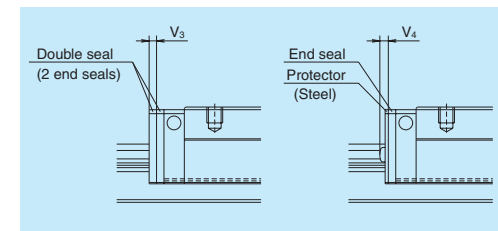

Fig. 12

(5) Cap to plug the rail mounting bolt hole

Table 15 Caps to plug rail bolt hole

Model No.	Bolt to secure rail	Cap reference No.	Quantity /case
LW17, LW21, LW27	M4	LG-CAP/M4	20
LW35	M6	LG-CAP/M6	20
LW50	M8	LG-CAP/M8	20

(6) Bellows

· Make tap holes to the rail end face to fix the bellows mounting plate. NSK processes tap holes to the rail end face when ordered with a linear guide.

Dimension tables of bellows
LW series

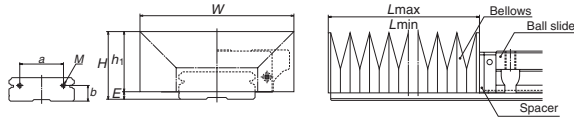

Fig. 13

Bellows reference number

J A W 21 L 08

Bellows

A: Bellows for the ends
B: Middle bellows

Number of BL (fold number)
N: High type L: Low type

Size number of linear guide

Bellows for LW series

Table 16 Dimensions of bellows

Unit: mm

Model No.	H	h ₁	E	W	P	a	b	BL minimum length	Tap (M) x depth
JAW17N	25.5	23	2.5	68	15	22	6	17	M3 x 6
JAW21N	29	26	3	75	17	26	7	17	M3 x 6
JAW27N	37	33	4	85	20	28	10	17	M3 x 6
JAW35L	34	30	4	100	14	48	12	17	M4 x 8
JAW35N	41	37		115	20				
JAW50L	46.5	42	4.5	135	20	70	14	17	M4 x 8
JAW50N	56.5	52		160	30				

Table 17 Numbers of folds (BL) and length of bellows

Unit: mm

Model No.	Number of BL	2	4	6	8	10	12	14	16	18	20
		L _{min}	34	68	102	136	170	204	238	272	306
JAW17N	Stroke	176	352	528	704	880	1 056	1 232	1 408	1 584	1 760
	L _{max}	210	420	630	840	1 050	1 260	1 470	1 680	1 890	2 100
JAW21N	Stroke	204	408	612	816	1 020	1 224	1 428	1 632	1 836	2 040
	L _{max}	238	476	714	952	1 190	1 428	1 666	1 904	2 142	2 380
JAW27N	Stroke	246	492	738	984	1 230	1 476	1 722	1 968	2 214	2 460
	L _{max}	280	560	840	1 120	1 400	1 680	1 960	2 240	2 520	2 800
JAW35L	Stroke	162	324	486	648	810	972	1 134	1 296	1 458	1 620
	L _{max}	196	392	588	784	980	1 176	1 372	1 568	1 764	1 960
JAW35N	Stroke	218	436	654	872	1 090	1 308	1 526	1 744	1 962	2 180
	L _{max}	252	504	756	1 008	1 260	1 512	1 764	2 016	2 268	2 520
JAW50L	Stroke	246	492	738	984	1 230	1 476	1 722	1 968	2 214	2 460
	L _{max}	280	560	840	1 120	1 400	1 680	1 960	2 240	2 520	2 800
JAW50N	Stroke	386	772	1 158	1 544	1 930	2 316	2 702	3 088	3 474	3 860
	L _{max}	420	840	1 260	1 680	2 100	2 520	2 940	3 360	3 780	4 200

Note: The values of an odd number BL quantity (3, 5, 7, ...) can be obtained by adding two values of even number BL on the both sides, then by dividing the sum by 2.

8. Reference number

Reference numbers shall be set to individual NSK linear guide when its specifications are finalized, and it is indicated on its specification drawing.

Please specify the reference number, except design serial number, to identify the product when ordering, requiring estimates, or inquiring about specifications from NSK.

(1) Reference number for preloaded assembly

LW 35 1000 EL C 2 - P6 1**

Series name	Preload code (See page A173.)
Size	0: Z0, 1: Z1, 3: Z3
Rail length (mm)	Accuracy code (See Table 19.)
Ball slide shape code (See page A171.)	Design serial number
Material/surface treatment code (See Table 18.) C: Special high carbon steel (NSK standard)	Added to the reference number. Number of ball slides per rail

(2) Reference number for random-matching type

LAW 35 EL Z -K

Random-matching ball slide series code LAW: LW Series random-matching ball slide	Option code -K: Equipped with NSK K1 -F: Fluoride low temperature chrome plating + AS2 grease -F50: Fluoride low temperature chrome plating + LG2 grease
Size	Preload code No code: Fine clearance, Z: Slight preload
Ball slide shape code (See page A171.)	

L1W35 1000 L CN - PC Z**

Random-matching rail series code L1W: LW Series random-matching rail	Preload code (See page A173.) T: Fine clearance. Z: Slight preload
Size	Accuracy code: PC PC: Normal grade is only available.
Rail length (mm)	Design serial number
Rail shape code: L L: Standard	Added to the reference number. *Butting rail specification
Material/surface treatment code (See Table 18.)	N: Non-butting. L: Butting specification

*Please consult with NSK for butting rail specification.

The reference number coding for the assembly of random-matching type is the same as that of preloaded assembly. However, only preload codes of "fine clearance T" and "slight preload Z" are available (refer to page A173).

Table 18 Material/surface treatment code

Code	Description
C	Special high carbon steel (NSK standard)
D	Special high carbon steel with surface treatment
Z	Other, special

Table 19 Accuracy code

Accuracy	Standard (Without NSK K1)	With NSK K1	With NSK K1 for food and medical equipment
High precision grade	P5	K5	F5
Precision grade	P6	K6	F6
Normal grade	PN	KN	FN
Normal grade (random-matching type)	PC	KC	FC

Note: Refer to pages A38 and A61 for NSK K1 lubrication unit.

(9) Dimensions

LW-EL

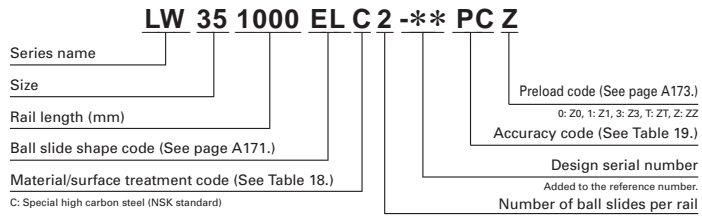

Front view

Side view

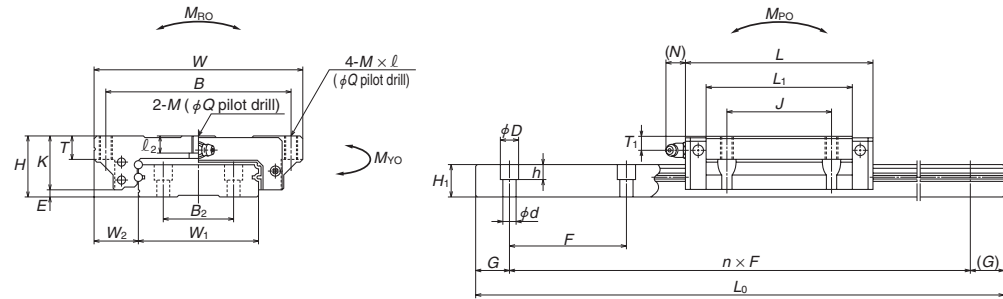

Reference number for ball slide of random-matching type

LAW 35 EL Z -K

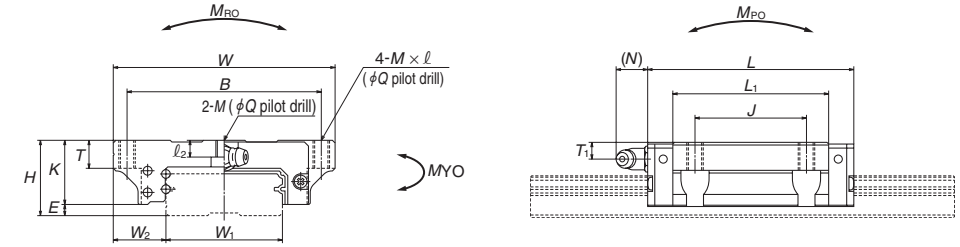
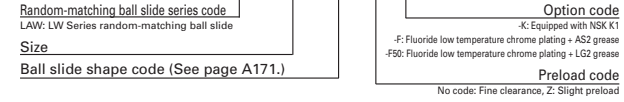

Reference number for rail of random-matching type

Rail L1W35 1000 LCN - PC Z**

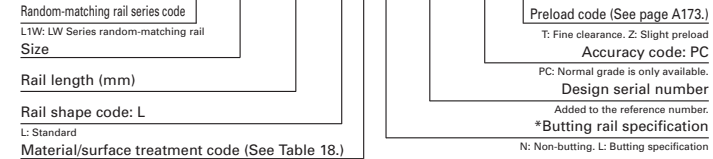

*Please consult with NSK for butting rail specification.

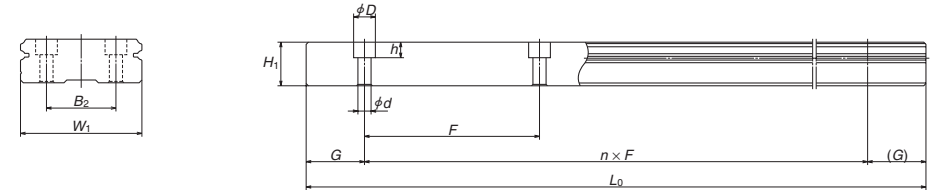

Model No.	Assembly			Ball slide											Width	Height		
	Height	Width	Length	Mounting hole								Grease fitting						
				B	J	M × pitch × ℓ	ℓ ₂	Q	L ₁	K	T	Hole size	T ₁	N			W ₁	
LW17EL	17	2.5	13.5	60	51.4	53	26	M4×0.7×6	3.2	3.3	35	14.5	6	φ3	4	3	33	8.7
LW21EL	21	3	15.5	68	58.8	60	29	M5×0.8×8	3.7	4.4	41	18	8	M6×0.75	4.5	11	37	10.5
LW27EL	27	4	19	80	74	70	40	M6×1×10	6	5.3	56	23	10	M6×0.75	6	11	42	15
LW35EL	35	4	25.5	120	108	107	60	M8×1.25×14	9	6.8	84	31	14	M6×0.75	8	11	69	19
LW50EL	50	4.5	36	162	140.6	144	80	M10×1.5×18	14	8.6	108	45.5	18	Rc1/8	14	14	90	24

Rail				Basic load rating								Weight		
Pitch	Mounting bolt hole	G	Max. length L _{0max} () for stainless	Dynamic		Static	Static moment (N-m)				Ball slide	Rail		
				[50km]	[100km]		C ₀	M _{PO}		M _{YO}				
				C ₅₀ (N)	C ₁₀₀ (N)	(N)		One slide	Two slides	One slide	Two slides	(kg)	(kg/m)	
B ₂	F	d × D × h	(reference)											
18	40	4.5×7.5×5.3	15	1 000	5 600	4 450	11 300	135	44	288	37	242	0.2	2.1
22	50	4.5×7.5×5.3	15	1 600	6 450	5 150	13 900	185	65.5	400	55	335	0.3	2.9
24	60	4.5×7.5×5.3	20	2 000	12 800	10 200	26 900	400	171	970	143	815	0.5	4.7
40	80	7×11×9	20	2 000	33 000	26 400	66 500	1 690	645	3 550	545	2 990	1.5	9.6
60	80	9×14×12	20	2 000	61 500	48 500	117 000	3 900	1 530	8 200	1 280	6 900	4.0	15.8

Note: The basic load rating comply with the ISO standard. (ISO 14728-1, 14728-2)
 C₅₀: the basic dynamic load rating for 50 km rated fatigue life C₁₀₀: the basic dynamic load rating for 100 km rated fatigue life

- | | |
|-----------------------------------|-------------|
| 1. PU Series | A187 |
| 2. LU Series | A197 |
| 3. PE Series | A209 |
| 4. LE Series | A219 |
| 5. Miniature LH
Series | A233 |
| 6. LL Series | A243 |

A-5-2 Liquid Crystal Display and Semiconductor

A-5-2.1 PU Series (Miniature type)

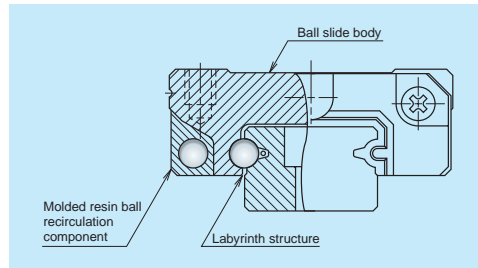
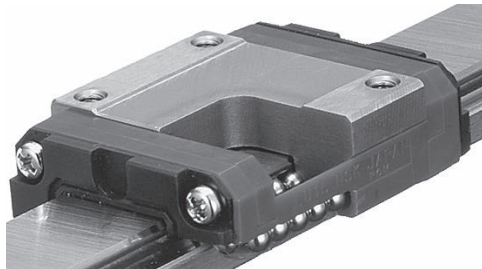

Fig. 1

1. Features

(1) Motion performance

Newly designed recirculation component facilitates smooth circulation of steel balls.

(2) Lightweight

The ball slide is fabricated to be approximately 20% lighter than LU Series by the application of resin to a part of its body.

(3) Reduced noise intensity

Resin components applied in ball circulating circuits reduce collision noise between steel balls and the inner wall of circulating circuits.

(4) Low dust generation

The structure is designed to prevent dust generation.

(5) Excellent dust-proofing

It is designed to minimize the clearance between the side of rails and the inner walls of the slide, and prevent foreign matters from entering the ball slide.

(6) High corrosion resistance

High corrosion-resistant martensite stainless steel is incorporated as a standard feature to provides excellent corrosion resistance.

(7) Easy to handle

Safety design includes a retainer that prevents steel balls from dropping out of the ball slide even when the slide is removed from the rail.

(8) Long-term maintenance-free

Superb features of NSK K1 Lubrication unit realize a long-term, maintenance-free operation.

(9) Fast delivery

Lineup of random-matching rails and ball slides facilitates fast delivery. (PU09 to PU15)

2. Ball slide shape

Ball slide Model	Shape/installation method	Type (Upper row, Rating: Lower row, Ball slide length)	
		Standard type	High-load type
AR TR AL UR BL BR		Standard TR, AR, AL	Long UR, BL, BR

3. Accuracy and preload

(1) Running parallelism of ball slide

Table 1

Unit: μm

Rail length (mm)	Preloaded assembly type (not random matching)				Random-matching type
	Super precision P4	High precision P5	Precision grade P6	Normal grade PN	Normal grade PC
over 50	2	2	4.5	6	6
50 – 80	2	3	5	6	6
80 – 125	2	3.5	5.5	6.5	6.5
125 – 200	2	4	6	7	7
200 – 250	2.5	5	7	8	8
250 – 315	2.5	5	8	9	9
315 – 400	3	6	9	11	11
400 – 500	3	6	10	12	12
500 – 630	3.5	7	12	14	14
630 – 800	4.5	8	14	16	16
800 – 1 000	5	9	16	18	18
1 000 – 1 250	6	10	17	20	20

(2) Accuracy standard

The preloaded assembly has four accuracy grades; Super precision P4, High precision P5, Precision grade P6, and normal grade PN, while the random-matching type has Normal grade PC only.

Table 2 shows the accuracy standard for the preloaded assembly type while **Table 3** shows the accuracy standard for the random-matching types.

• **Tolerance of preloaded assembly**

Characteristics	Accuracy grade	Super precision P4	High precision P5	Precision grade P6	Normal grade PN
Mounting height H Variation of H (All ball slides on a set of rails)		± 10 5	± 15 7	± 20 15	± 40 25
Mounting width W_2 or W_3 Variation of W_2 or W_3 (All ball slides on reference rail)		± 15 7	± 20 10	± 30 20	± 50 30
Running parallelism of surface C to surface A Running parallelism of surface D to surface B		Shown in Table 1 and Fig. 2			

• **Tolerance of random-matching type: Normal grade PC**

Characteristics	Model No.	PU09, 12 and 15
Mounting height H		± 20
Variation of mounting height H		15 ^① 30 ^②
Mounting width W_2 or W_3		± 20
Variation of mounting width W_2 or W_3		20
Running parallelism of surface C to surface A Running parallelism of surface D to surface B		Shown in Table 1 and Fig. 2

Notes: ① Variation on the same rail ② Variation on multiple rails

(3) Assembled accuracy

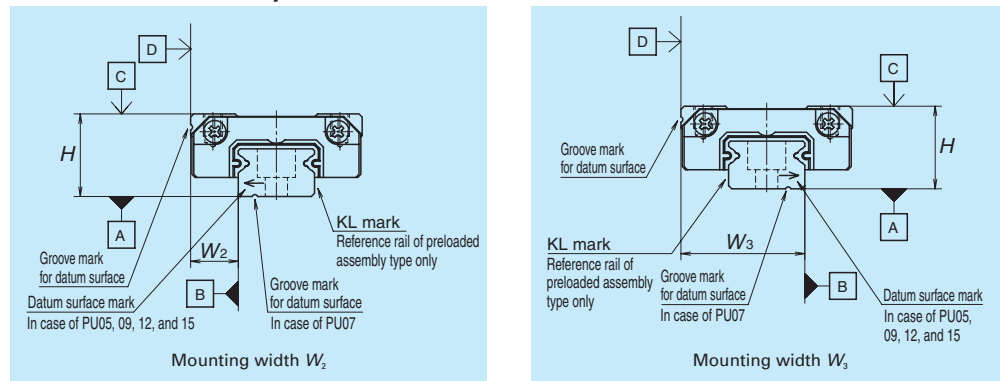

Fig. 2

Note: Please refer to page A67 for marks on the datum surfaces.

(4) Preload and rigidity

We offer three levels of preload: Slight preload Z1 and Fine clearance Z0 for preloaded assembly type, along with Fine clearance ZT for random-matching type. Values for preload and rigidity of the preloaded assembly type are shown in **Table 4**. Rigidities are for the median of the preload range.

• **Preload and rigidity of preloaded assembly**

Model No.	Preload (N)	Rigidity (N/ μm)	
	Slight preload (Z1)	Slight preload (Z1)	
Standard type	PU05TR	0 – 3	17
	PU07AR	0 – 8	22
	PU09TR	0 – 10	30
	PU12TR	0 – 17	33
High-load type	PU15AL	0 – 33	45
	PU09UR	0 – 14	46
	PU12UR	0 – 25	52
PU15BL	0 – 51	75	

Note: Clearance of Fine clearance Z0 is 0 to 3 μm . Therefore, preload is zero.

• **Clearance of random-matching type**

Model No.	Fine clearance ZT	
Standard type	PU09TR	3 or less
	PU12TR	
	PU15AL	
High-load type	PU09UR	5 or less
	PU12UR	
	PU15BL	

4. Maximum rail length

Table 6 shows the limitations of rail length (maximum length). However, the limitations vary by accuracy grade.

Series	Material	Size				
		05	07	09	12	15
PU	Stainless steel	210	375	600	800	1 000

Note: Rails can be butted if user requirement exceeds the rail length shown in the table. Please consult NSK.

5. Installation

(1) Permissible values of mounting error

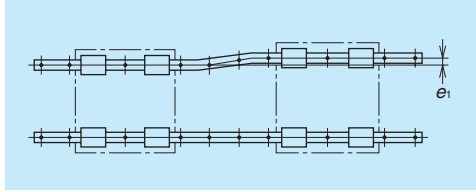

Fig. 3

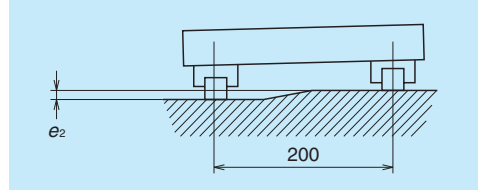

Fig. 4

Table 7

Unit: μm

Value	Preload	Model No.				
		PU05	PU07	PU09	PU12	PU15
Permissible values of parallelism in two rails e_1	Z0, ZT	10	12	15	20	25
	Z1	7	10	13	15	21
Permissible values of parallelism (height) in two rails e_2	Z0, ZT	150 $\mu\text{m}/200\text{ mm}$				
	Z1	90 $\mu\text{m}/200\text{ mm}$				

(2) Shoulder height of the mounting surface and corner radius r

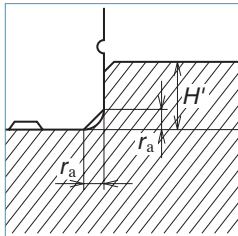

Fig. 5 Shoulder for the rail datum surface

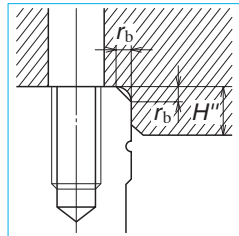

Fig. 6 Shoulder for the ball slide datum surface

Table 8

Unit: mm

Model No.	Corner radius (maximum)		Shoulder height	
	r_a	r_b	H'	H''^*
PU05	0.2	0.2	0.7	2.3
PU07	0.2	0.3	1.2	2.5
PU09	0.3	0.3	1.9	2.6
PU12	0.3	0.3	2.5	3.4
PU15	0.3	0.5	3.5	4.4

*) H'' is the minimum recommended value based on the dimension T in dimension table.

6. Lubrication accessory

Model of PU15 can select drive-in type grease fitting as an option.

For the models of PU05 to PU12, apply grease directly to the ball grooves of rail using a point nozzle.

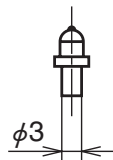

Drive-in type

7. Dust-proof components

(1) Standard specification

An end seal provided to both ends of a ball slide as a standard feature.

Seal friction per standard ball slide is shown in Table 9.

Table 9 Seal friction per ball slide (maximum value)

Unit: N

Series	Size	05	07	09	12	15
PU		0.3	0.3	0.5	0.5	0.5

(2) NSK K1™ lubrication unit

Table 10 shows the dimension of linear guides equipped with the NSK K1 lubrication unit.

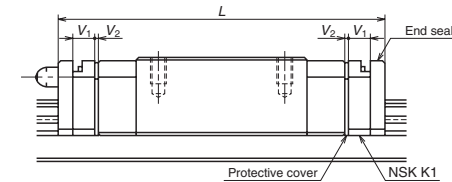

Table 10

Unit: mm

Model No.	Ball slide length	Ball slide model	Standard ball slide length	Ball slide length equipped with two NSK K1 L	Thickness of NSK K1, V_1	Thickness of protective cover, V_2
PU05	Standard	TR	19.4	24.4	2	0.5
PU07	Standard	AR	23.4	29.4	2.5	0.5
PU09	Standard	TR	30	36.4	2.7	0.5
	Long	UR	41	47.4		
PU12	Standard	TR	35	42	3	0.5
	Long	UR	48.7	55.7		
PU15	Standard	AL	43	51.2	3.5	0.6
	Long	BL	61	69.2		

Note: Ball slide length equipped with NSK K1 =

$$(\text{Standard ball slide length}) + (\text{Thickness of NSK K1, } V_1 \times \text{Number of NSK K1}) + (\text{Thickness of the protective cover } V_2 \times 2)$$

PU Series

8. Reference number

Reference numbers shall be set to individual NSK linear guide when its specifications are finalized, and it is indicated on its specification drawing.

Please specify the reference number, except design serial number, to identify the product when ordering, requiring estimates, or inquiring about specifications from NSK.

(1) Reference number for preloaded assembly

PU 15 0470 AL K 2 - P5 1**

Series name	PU	Size	15	Rail length (mm)	0470	Ball slide shape code (See page A188.)	AL	Material/surface treatment code (See Table 11.)	K	Preload code (See page A190.)	2	Accuracy code (See Table 12.)	**	Design serial number	P5	Number of ball slides per rail	1
-------------	----	------	----	------------------	------	--	----	---	---	-------------------------------	---	-------------------------------	----	----------------------	----	--------------------------------	---

0: Z0, 1: Z1

K: Stainless steel

(2) Reference number for random-matching type

PAU 15 ALS -K

Random-matching ball slide series code	PAU	Size	15	Ball slide shape code (See page A188.)	ALS	Option code	-K	Material code	S
--	-----	------	----	--	-----	-------------	----	---------------	---

PAU: PU Series random-matching ball slide

-K: Equipped with NSK K1

S: Stainless steel

Rail P1U15 0470 RKN - PC T**

Random-matching rail series code	P1U	Size	15	Rail length (mm)	0470	Rail shape code	R	Material/surface treatment code (See Table 11.)	K	Preload code (See page A190.)	N	Accuracy code: PC	**	Design serial number	PC	Butting rail specification	T
----------------------------------	-----	------	----	------------------	------	-----------------	---	---	---	-------------------------------	---	-------------------	----	----------------------	----	----------------------------	---

P1U: PU Series random-matching rail

T: Fine clearance

PC: Normal grade is only available.

S: PU09, 12. R: PU15

N: Non-butting. L: Butting specification

*Please consult with NSK for butting rail specification.

The reference number coding for the assembly of random-matching type is the same as that of preloaded assembly. However, only preload code of "fine clearance T" is available (refer to page A190).

Table 11 Material/surface treatment code

Code	Description
K	Stainless steel
H	Stainless steel with surface treatment
Z	Other, special

Table 12 Accuracy code

Accuracy	Standard (Without NSK K1)	With NSK K1	With NSK K1 for food and medical equipment
Super precision grade	P4	K4	F4
High precision grade	P5	K5	F5
Precision grade	P6	K6	F6
Normal grade	PN	KN	FN
Normal grade (random-matching type)	PC	KC	FC

Note: Refer to pages A38 and A61 for the NSK K1 lubrication unit.

9. Dimensions

PU-TR, AR, AL (Standard type / Standard)
 PU-UR, BL (High-load type / Long)

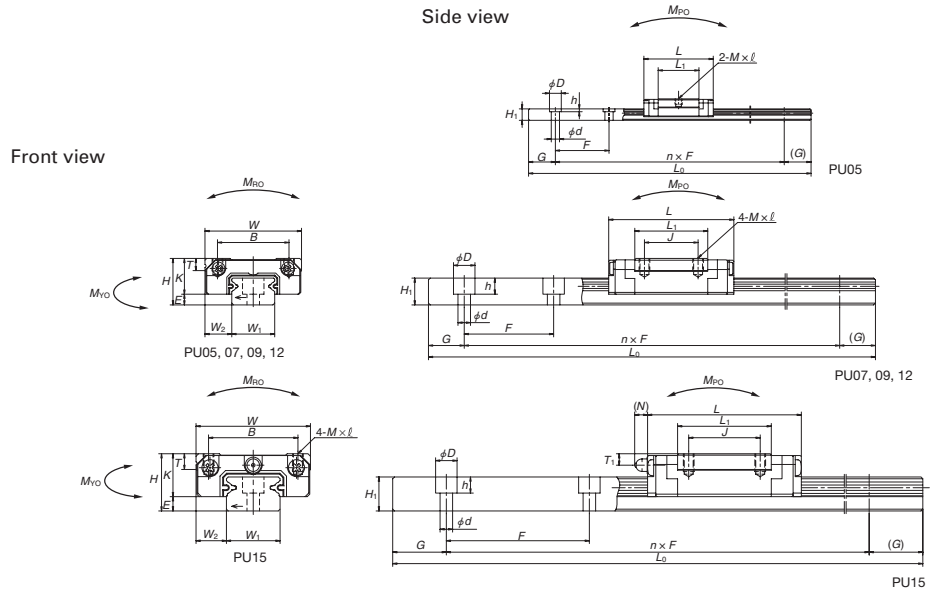
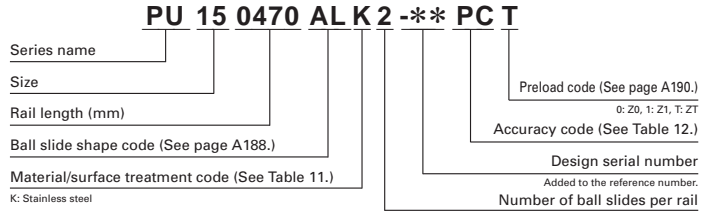

Model No.	Assembly			Ball slide										Width	Height	
	Height	Width	Length	Mounting hole						Oil hole						
				B	J	$M \times \text{pitch} \times \ell$	L_1	K	T	Hole size	T_1	N	W_1			H_1
PU05TR	6	1	3.5	12	19.4	8	—	M2×0.4×1.5	11.4	5	2.3	$\phi 0.9$	1.5	—	5	3.2
PU07AR	8	1.5	5	17	23.4	12	8	M2×0.4×2.4	13.3	6.5	2.45	$\phi 1.5$	1.8	—	7	4.7
PU09TR	10	2.2	5.5	20	30	10	M3×0.5×3	19.6	7.8	2.6	—	—	—	9	5.5	
PU09UR					41	15		16								30.6
PU12TR	13	3	7.5	27	35	15	M3×0.5×3.5	20.4	10	3.4	—	—	—	12	7.5	
PU12UR					48.7	20		20								34.1
PU15AL	16	4	8.5	32	43	20	M3×0.5×5	26.2	12	4.4	$\phi 3$	3.2	(3.6)	15	9.5	
PU15BL					61	25		25								44.2

Notes: 1) The ball slide of PU05TR has only two mounting tap holes in the center.

Reference number for ball slide of random-matching type

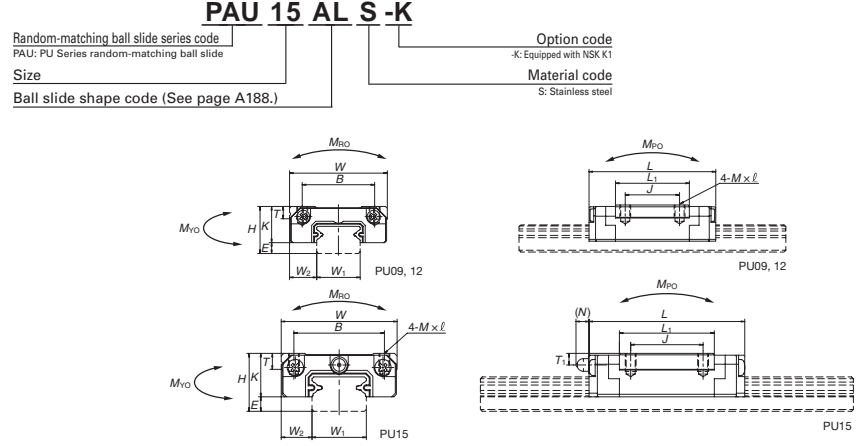

Reference number for rail of random-matching type

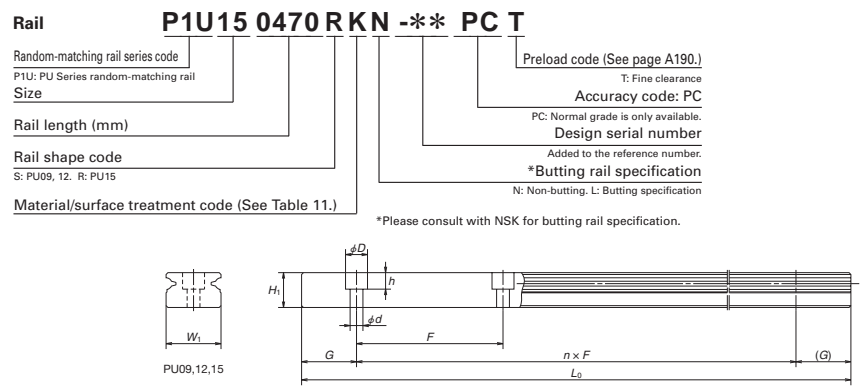

Rail				Basic load rating							Weight		
Pitch	Mounting bolt hole	G	Maximum length	Dynamic		Static	Static moment (N·m)				Ball slide	Rail	
				[50km]	[100km]		C_0	M_{PO}		M_{YO}			
				C_{50} (N)	C_{100} (N)			One slide	Two slides	One slide			Two slides
15	2.3×3.3×0.8	5	210	520	410	775	2.06	1.28	9.90	1.28	9.90	4	11
15	2.4×4.2×2.3	5	375	1 090	860	1 370	5.20	2.70	21.8	2.70	21.8	8	23
20	3.5×6×4.5	7.5	600	1 490	1 180	2 150	9.90	6.10	41.0	6.10	41.0	16	35
				2 100	1 670	3 500	16.2	15.6	88.0	15.6	88.0		
25	3.5×6×4.5	10	800	2 830	2 250	3 500	21.1	11.4	73.5	11.4	73.5	32	65
				4 000	3 150	5 700	34.5	28.3	174	28.3	174		
40	3.5×6×4.5	15	1 000	5 550	4 400	6 600	49.5	25.6	190	25.6	190	59	105
				8 100	6 400	11 300	84.5	69.5	435	69.5	435		

2) The basic load rating comply with the ISO standard. (ISO 14728-1, 14728-2)
 C_{50} : the basic dynamic load rating for 50 km rated fatigue life C_{100} : the basic dynamic load rating for 100 km rated fatigue life
 3) To fix rail of PU05TR, use M2 x 0.4 cross-recessed pan head machine screw for precision instrument.
 (JCS 10-70 No. 0 pan head machine screw No.1.)
 (JCIS: Japanese Camera Industrial Standard.)

A-5-2.2 LU Series (Miniature type)

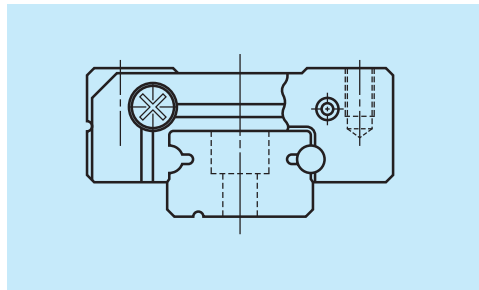

Fig. 1 LU Series

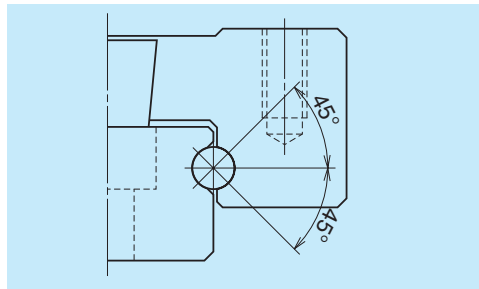

Fig. 2 Balls are in contact.

1. Features

(1) Super-small type

This compact guide owes its design to the single ball groove on both right and left sides (Gothic arch).

(2) Equal load carrying capacity in vertical and lateral directions

The contact angle is set at 45 degrees, thus facilitating the equal load carrying capacity in vertical and lateral directions. This also provides equal rigidity in both directions.

(3) Stainless steel is also standardized

Items made of the martensitic stainless steel are available as standard.

(4) Some series have a ball retainer

Ball slide types AR and TR come with a ball retainer. Balls are retained in the retainer and do not fall out when the ball slide is withdrawn from the rail. (Ball slides of random-matching type as well as LU15 come with ball retainer.)

(5) Fast delivery

Random-matching of rails and ball slides are available. (LU09 to LU15)

2. Ball slide shape

Ball slide Model	Shape/installation method	Type (Upper row, Rating: Lower row, Ball slide length)	
		Standard type Standard	High-load type Long
AL TL AR TR BL UL		AL, TL, TR, AR 	BL, UL

Specification	Detail	Type	
		Mounting hole	Normal
Ball retainer	Large	TL, TR	UL
	Without	AL*, TL	BL*, UL
	With	AR, TR	-

*) LU15 is equipped with ball retainer

3. Accuracy and preload

(1) Running parallelism of ball slide

Table 1

Unit: μm

Rail length (mm)	Preloaded assembly type (not random matching)				Random-matching type
	Super precision P4	High precision P5	Precision grade P6	Normal grade PN	Normal grade PC
over 50	2	2	4.5	6	6
50 - 80	2	3	5	6	6
80 - 125	2	3.5	5.5	6.5	6.5
125 - 200	2	4	6	7	7
200 - 250	2.5	5	7	8	8
250 - 315	2.5	5	8	9	9
315 - 400	3	6	9	11	11
400 - 500	3	6	10	12	12
500 - 630	3.5	7	12	14	14
630 - 800	4.5	8	14	16	16
800 - 1000	5	9	16	18	18
1000 - 1250	6	10	17	20	20

(2) Accuracy standard

The preloaded assembly type has four accuracy grades; Super precision P4, High precision P5, Precision P6, and Normal grade PN, while the random-matching type has Normal grade PC only.

Table 2 shows the accuracy standard for the preloaded assembly type, while **Table 3** shows the accuracy standard for the random-matching type.

• **Tolerance of preloaded assembly**

Table 2 Unit: μm

Characteristics	Accuracy grade	Super precision P4	High precision P5	Precision grade P6	Normal grade PN
Mounting height H Variation of H (All ball slides on a set of rails)		± 10 5	± 15 7	± 20 15	± 40 25
Mounting width W_2 or W_3 Variation of W_2 or W_3 (All ball slides on reference rail)		± 15 7	± 20 10	± 30 20	± 50 30
Running parallelism of surface C to surface A Running parallelism of surface D to surface B		Refer to Table 1 and Fig. 3			

• **Tolerance of random-matching type: Normal grade PC**

Table 3 Unit: μm

Characteristics	Accuracy grade	LU09, 12, 15
Mounting height H		± 20
Variation of mounting height H		40
Mounting width W_2 or W_3		± 20
Variation of mounting width W_2 or W_3		40
Running parallelism of surface C to surface A Running parallelism of surface D to surface B		Refer to Table 1 and Fig. 3

(3) Assembled accuracy

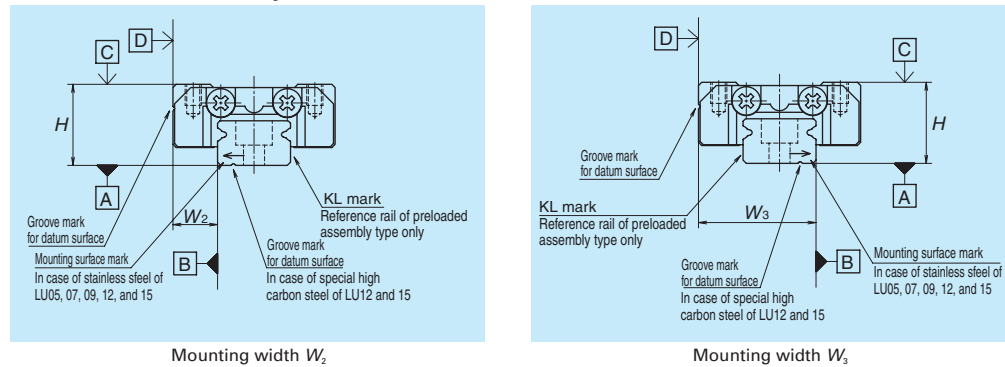

Fig. 3

Note: Please refer to page A67 for marks on the datum surfaces.

(4) Preload and rigidity

We offer three levels of preload: Slight preload Z1 and Fine clearance Z0, along with random-matching type of Fine clearance ZT. Values for preload and rigidity of the preloaded assembly type are shown in **Table 4**. Rigidities are for the median of the preload range.

• **Preload and rigidity of preloaded assembly**

Table 4

Model No.	Preload (N)	Rigidity (N/ μm)
	Slight preload (Z1)	Slight preload (Z1)
Standard type		
LU05 TL	0 – 3	15
LU07 AL	0 – 8	22
LU09 AL, TL	0 – 12	26
LU09 AR, TR	0 – 10	30
LU12 AL, TL	0 – 17	33
LU12 AR, TR	0 – 17	33
LU15 AL	0 – 33	45
High-load type		
LU09 BL, UL	0 – 17	43
LU12 BL, UL	0 – 25	52
LU15 BL	0 – 51	75

Note: Clearance of Fine clearance Z0 is 0 to 3 μm . Therefore, preload is zero. However, the clearance of the Z0 of PN grade is 3 to 10 μm .

• **Clearance of random-matching type**

Table 5 Unit: μm

Model No.	Fine clearance ZT
LU09	0 – 15
LU12	
LU15	

4. Maximum rail length

Table 6 shows the limitations of rail length.

However, the limitations vary by accuracy grades.

Table 6 Length limitation of rails Unit: mm

Series	Size Material					
		05	07	09	12	15
LU	Special high carbon steel	–	–	1 200	1 800	2 000
	Stainless steel	210	375	600	800	1 000

Note: Rails can be butted if user requirement exceeds the rail length shown in the table. Please consult NSK.

5. Installation

(1) Permissible values of mounting error

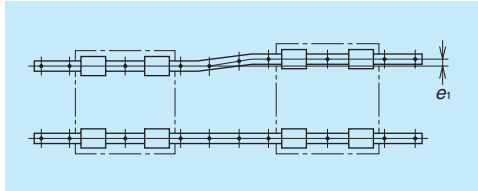

Fig. 4

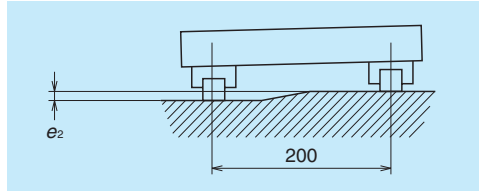

Fig. 5

Table 7

Unit: μm

Value	Preload	Model No.				
		LU05	LU07	LU09	LU12	LU15
Permissible values of parallelism in two rails e_1	Z0, ZT	10	12	15	20	25
	Z1	7	10	13	15	21
Permissible values of parallelism (height) in two rails e_2	Z0, ZT	150 $\mu\text{m}/200\text{ mm}$				
	Z1	90 $\mu\text{m}/200\text{ mm}$				

(2) Shoulder height of the mounting surface and corner radius r

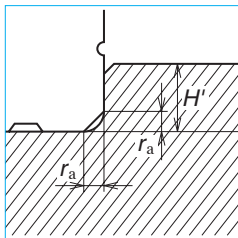

Fig. 6 Shoulder for the rail datum surface

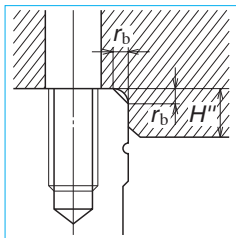

Fig. 7 Shoulder for the ball slide datum surface

Table 8

Unit: mm

Model No.	Corner radius (maximum)		Shoulder height	
	r_a	r_b	H'	H''
LU05	0.2	0.2	0.7	2
LU07	0.2	0.3	1.2	3
LU09	0.3	0.3	1.9	3
LU12	0.3	0.3	2.5	4
LU15	0.3	0.5	3.5	5

6. Lubrication accessories

There is no standard grease fitting for LU05 to LU15.

For the LU Series, apply grease directly to the ball grooves of rail using a point nozzle.

7. Dust-proof components

(1) Standard specification

End seal: Provided to both ends of the ball slide as a standard feature.

LU05TL, LU07AL, LU09AL, and LU09TL can install the end seal as an option.

• Seal friction per standard ball slide is shown in Table 9.

Table 9 Seal friction per ball slide (maximum value)

Unit: N

Series	Size	05	07	09	12	15
		LU	0.3	0.3	0.5	0.5

(2) NSK K1™ lubrication unit

The installed dimensions of the NSK K1 lubrication unit are shown in Table 10.

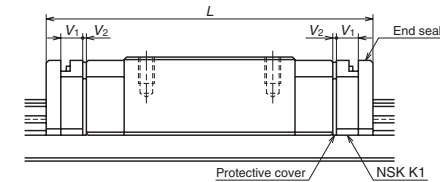

Table 10

Unit: mm

Model No.	Ball slide length	Ball slide model	Standard ball slide length	Ball slide length installed with two NSK K1 L	Per NSK K1 thickness V_1	Protective cover thickness V_2
LU05	Standard	TL	18*	24.4	2.0	0.5
LU07	Standard	AL	20.4*	29.4	2.5	0.5
LU09	Standard	AR, TR	30	36.4	2.7	0.5
	Long	BL, UL	41	47.4		
LU12	Standard	AR, TR	35.2	42.2	3.0	0.5
	Long	BL, UL	47.5	54.5		
LU15	Standard	AL	43.6	51.8	3.5	0.6
	Long	BL	61	69.2		

*) Standard ball slide length of LU05TL, LU07AL, LU09AL and LU09TL does not include the thickness of the end seal (1.5 mm). However, it includes the height of the screw head for end cap installation (Included length – LU05, 0.8 mm; LU07, no projection; LU09, 1 mm)

Note: Ball slide length equipped with NSK K1 =

$$(\text{Standard ball slide length}) + (\text{Thickness of NSK K1, } V_1 \times \text{Number of NSK K1}) + (\text{Thickness of the protective cover } V_2 \times 2)$$

8. Reference number

Reference numbers shall be set to individual NSK linear guide when its specifications are finalized, and it is indicated on its specification drawing.

Please specify the reference number, except design serial number, to identify the product when ordering, requiring estimates, or inquiring about specifications from NSK.

(1) Reference number for preloaded assembly

LU 12 0270 ARK 2 -** P5 1

Series name	Size	Rail length (mm)	Ball slide shape code (See page A198.)	Material/surface treatment code (See Table 11.) <small>C: Special high carbon steel (NSK standard), K: Stainless steel</small>	Preload code (See page A200.) <small>0: Z0, 1: Z1</small>
					Accuracy code (See Table 12.)
					Design serial number <small>Added to the reference number.</small>
					Number of ball slides per rail

(2) Reference number for random-matching type

LAU 12 ARS -K

Ball slide	Random-matching ball slide series code <small>LAU: LU Series random-matching ball slide</small>	Size	Ball slide shape code (See page A198.)	Option code <small>-K: Equipped with NSK K1</small>	Material code <small>No code: Special high carbon steel (NSK standard), S: Stainless steel</small>
------------	--	------	--	--	---

L1U12 0270 RKN -** PC T

Rail	Random-matching rail series code <small>L1U: LU Series random-matching rail</small>	Size	Rail length (mm)	Rail shape code <small>L: Standard. R: LU09 and LU12 standard, equipped with ball retainer. S: LU09 and LU12 with ball retainer and mounting holes for M3 T: LU09 and LU12 without ball retainer and mounting holes for M3</small>	Preload code (See page A200.) <small>T: Fine clearance</small>
					Accuracy code: PC <small>PC: Normal grade is only available.</small>
					Design serial number <small>Added to the reference number.</small>
					*Butting rail specification <small>N: Non-butting. L: Butting specification</small>

*Please consult with NSK for butting rail specification.

The reference number coding for the assembly of random-matching type is the same as that of the preloaded assembly. However, only the preload code of "Fine clearance T" is available (refer to page A200).

Table 11 Material/surface treatment code

Code	Description
C	Special high carbon steel (NSK standard)
K	Stainless steel
D	Special high carbon steel with surface treatment
H	Stainless steel with surface treatment
Z	Other, special

Table 12 Accuracy code

Accuracy	Standard (Without NSK K1)	With NSK K1
Super precision grade	P4	K4
High precision grade	P5	K5
Precision grade	P6	K6
Normal grade	PN	KN
Normal grade (random-matching type)	PC	KC

Note: Refer to page A38 for NSK K1 lubrication unit.

9. Dimensions

- LU-AL (Standard type / Standard, LU15 is equipped with ball retainer)
- LU-TL (Standard type / Standard, Large mounting hole)
- LU-AR (Standard type / Standard, With ball retainer)
- LU-TR (Standard type / Standard, Large mounting hole, with ball retainer)

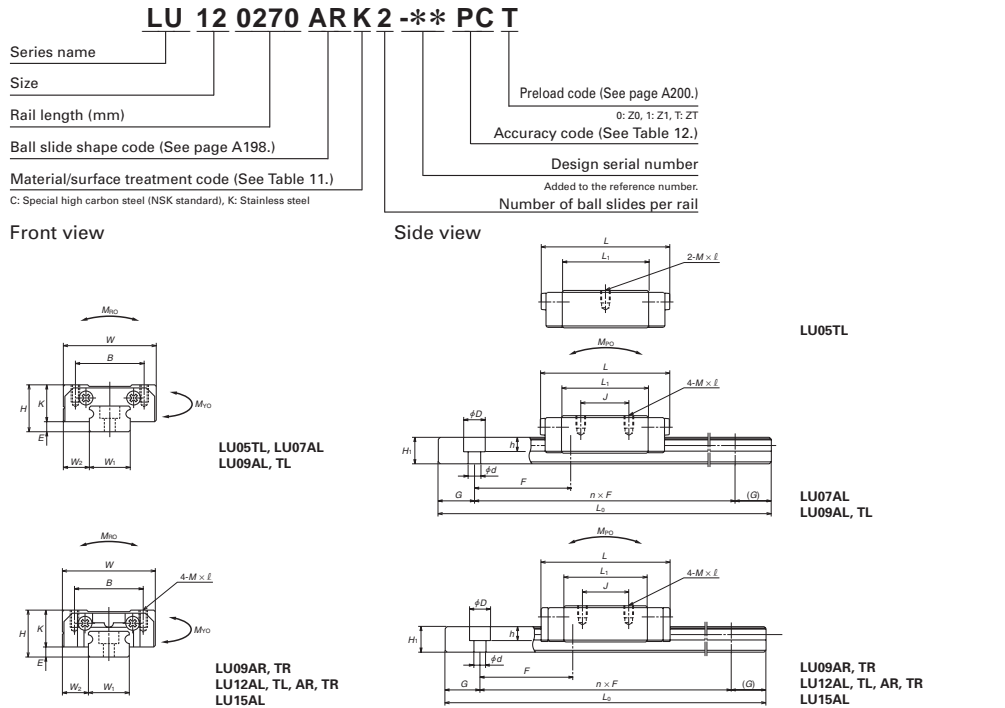

Model No.	Assembly			Ball slide							Width	Height	Pitch
	Height	E	W ₂	Width	Length	Mounting hole			L ₁	K			
						B	J	M × pitch × l					
LU05TL	6	1	3.5	12	18	8	—	M2×0.4×1.5	12	5	5	3.2	15
LU07AL	8	1.5	5	17	20.4	12	8	M2×0.4×2.4	13.6	6.5	7	4.7	15
LU09AL LU09TL	10	2.2	5.5	20	26.8	15	13 10	M2×0.4×2.5 M3×0.5×3	18	7.8	9	5.5	20
LU09AR LU09TR	10	2.2	5.5	20	30	15	13 10	M2×0.4×2.5 M3×0.5×3	20	7.8	9	5.5	20
LU12AL LU12TL	13	3	7.5	27	34	20	15	M2.5×0.45×3 M3×0.5×3.5	21.8	10	12	7.5	25
LU12AR LU12TR	13	3	7.5	27	35.2	20	15	M2.5×0.45×3 M3×0.5×3.5	21.8	10	12	7.5	25
LU15AL	16	4	8.5	32	43.6	25	20	M3×0.5×4	27	12	15	9.5	40

Notes 1) LU05TL, LU07AL, LU09TL, LU09AR, LU09TR, LU12AR and LU12TR come in stainless steel only.
 2) Ball slide of LU05TL has only two mounting tap holes in the center.
 3) End seals of LU05TL, LU07AL, LU09AL and LU09TL are available on request.

Reference number for ball slide of random-matching type

Random matching with retainer: LU09 - 12 are AR/TR, LU15 is AL.

- LAU-AR (With ball retainer)
- LAU-TR (Large mounting hole, with ball retainer)
- LAU-AL (LU15 is equipped with ball retainer)

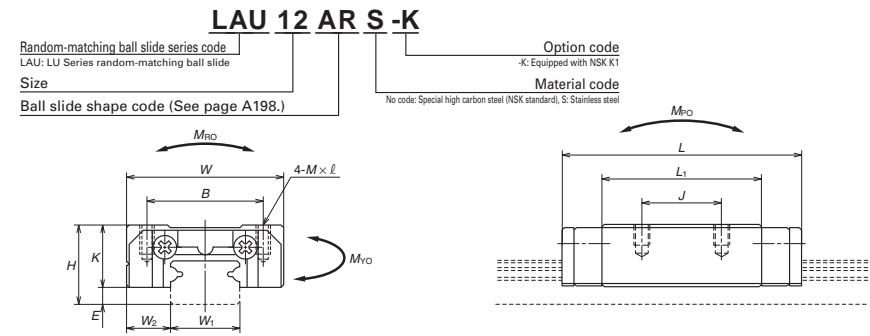

Reference number for rail of random-matching type

L1U12 0270 RKN - PC T**

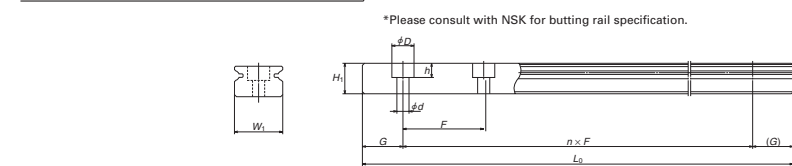
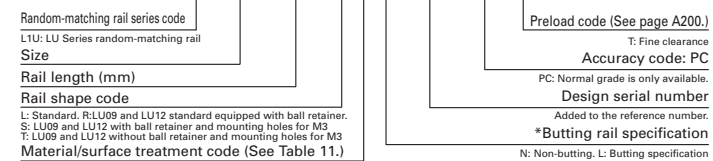

Rail	Mounting bolt hole	G	Max. length L _{0max} () for stainless	Basic load rating						Weight			
				Dynamic		Static	Static moment (N-m)				Ball slide (g)	Rail (g/100 mm)	
				[50km]	[100km]		C ₅₀	M _{RO}	M _{PO}				M _{YO}
2.3×3.3×1.5	d × D × h	(reference)	(210)	545	435	740	1.93	1.22	8.85	1.22	8.85	4	11
2.4×4.2×2.3			(375)	1 090	865	1 370	4.90	2.66	18.6	2.66	18.6	10	23
2.6×4.5×3			1 200 (600)	1 760	1 400	2 220	10.2	6.10	38.5	6.10	38.5	17	35
3.5×6×4.5			(600)	1 490	1 180	2 150	9.9	6.10	41.0	6.10	41.0	19	35
3×5.5×3.5			1 800 (800)	2 830	2 250	3 500	21.1	11.4	78.5	11.4	78.5	38	65
3.5×6×4.5			(800)	2 830	2 250	3 500	21.1	11.4	81.5	11.4	81.5	38	65
3.5×6×4.5			2 000 (1 000)	5 550	4 400	6 600	49.5	25.6	193	25.6	193	70	105

4) To fix rail of LU05TL, use M2 × 0.4 cross-recessed pan head machine screw for precision instrument. (JIS 10-70 No. 0 pan head machine screw No.1.) (JIS: Japanese Camera Industrial Standard.)
 5) The basic load rating comply with the ISO standard. (ISO 14728-1, 14728-2)
 C₅₀: the basic dynamic load rating for 50 km rated fatigue life C₁₀₀: the basic dynamic load rating for 100 km rated fatigue life

LU-BL (High-load type / Long)
 LU-UL (High-load type / Long, large mounting hole)

LU 12 0270 BL K 2 - P5 1**

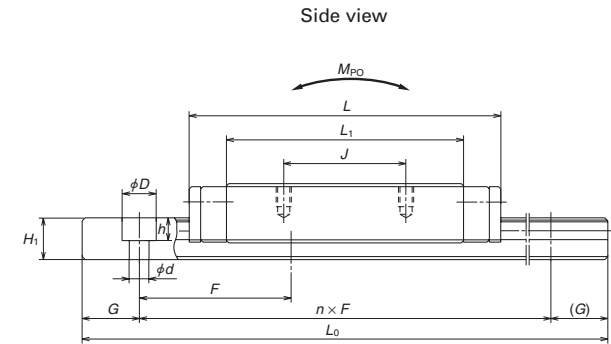
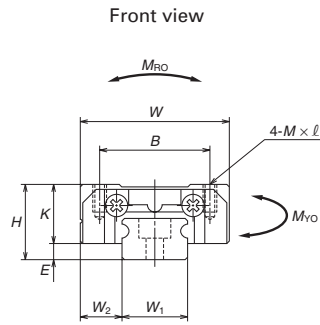
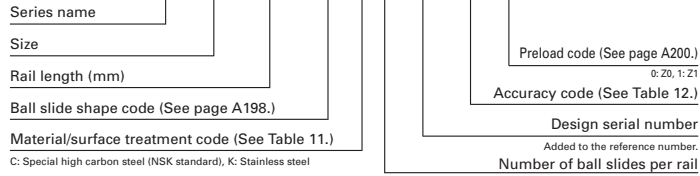

Model No.	Assembly			Ball slide							Width	Height	Pitch			
	Height	E	W ₂	Width	Length	Mounting hole			L ₁	K				W ₁	H ₁	F
						B	J	M × pitch × l								
LU09BL	10	2.2	5.5	20	41	15	16	M2×0.4×2.5	31.2	7.8	9	5.5	20			
LU09UL								M3×0.5×3								
LU12BL	13	3	7.5	27	47.5	20	20	M2.5×0.45×3	35.3	10	12	7.5	25			
LU12UL								M3×0.5×3.5								
LU15BL	16	4	8.5	32	61	25	25	M3×0.5×4	44.4	12	15	9.5	40			

Notes 1) LU09UL is available only in stainless steel.
 2) LU15BL is equipped with ball retainer.

													Unit: mm	
Rail			Basic load rating							Weight				
Mounting bolt hole d × D × h	G (reference)	Max. length L _{0max} () for stainless	³⁾ Dynamic		Static C ₀ (N)	M _{RO} (N)	Static moment (N-m)				Ball slide (g)	Rail (g/100 mm)		
			[50km]	[100km]			M _{PO}		M _{YO}					
			C ₅₀ (N)	C ₁₀₀ (N)	One slide	Two slides	One slide	Two slides						
2.6×4.5×3	7.5	1 200 (600)	2 600	2 070	3 900	17.9	17.2	98.0	17.2	98.0	29	35		
3.5×6×4.5														
3×5.5×3.5	10	1 800 (800)	4 000	3 150	5 700	34.5	28.3	169	28.3	169	59	65		
3.5×6×4.5														
3.5×6×4.5	15	2 000 (1 000)	8 100	6 400	11 300	84.5	69.5	435	69.5	435	107	105		

3) The basic load rating comply with the ISO standard. (ISO 14728-1, 14728-2)
 C₅₀: the basic dynamic load rating for 50 km rated fatigue life C₁₀₀: the basic dynamic load rating for 100 km rated fatigue life

A-5-2.3 PE Series (Miniature wide type)

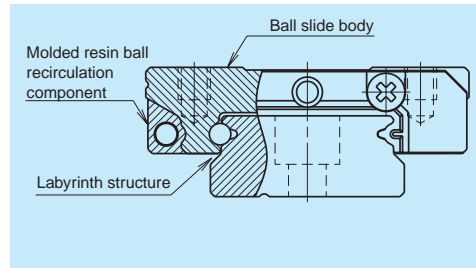

Fig. 1

1. Features

(1) Ideal for use of single rail

The PE Series linear guides are miniature and wide rail type. Thanks to the wide rail, load carrying capacity is high against moment load from rolling direction.

(2) Motion performance

Newly designed recirculation component facilitates smooth circulation of steel balls.

(3) Lightweight

The ball slide is fabricated to be approximately 20% lighter than that of the LE Series by the application of resin to a part of its body.

(4) Reduced noise intensity

Resin components applied in ball circulating circuits reduce collision noise between steel balls and the inner wall of circulating circuits.

(5) Low dust generation

The structure is designed to prevent dust generation.

(6) Excellent dust-proofing

It is designed to minimize the clearance between the side of rails and the inner walls of the slide, and prevent foreign matters from entering the ball slide.

(7) High corrosion resistance

High corrosion-resistant martensite stainless steel incorporated as a standard feature provides excellent resistance to corrosion.

(8) Easy to handle

Safety design includes a retainer that prevents steel balls from dropping out of the ball slide even when the slide is removed from the rail.

(9) Long-term maintenance-free

Equipped with NSK K1 Lubrication Unit realizes long-term, maintenance-free use.

(10) Fast delivery

Lineup of random-matching rails and ball slides in the series supports random matching and facilitates fast delivery. (PE09 to PE15)

2. Ball slide shape

Ball slide Model	Shape/installation method	Type (Upper row, Rating: Lower row, Ball slide length)	
		Standard type	High-load type
		Standard	Long
AR TR UR BR		AR, TR 	UR, BR

3. Accuracy and preload

(1) Running parallelism of ball slide

Table 1

Unit: μm

Rail length (mm)	Preloaded assembly type (not random matching)				Random-matching type
	Super precision P4	High precision P5	Precision grade P6	Normal grade PN	Normal grade PC
over 50	2	2	4.5	6	6
50 – 80	2	3	5	6	6
80 – 125	2	3.5	5.5	6.5	6.5
125 – 200	2	4	6	7	7
200 – 250	2.5	5	7	8	8
250 – 315	2.5	5	8	9	9
315 – 400	3	6	9	11	11
400 – 500	3	6	10	12	12
500 – 630	3.5	7	12	14	14
630 – 800	4.5	8	14	16	16
800 – 1 000	5	9	16	18	18
1 000 – 1 250	6	10	17	20	20

(2) Accuracy standard

The preloaded assembly type has four accuracy grades; Super precision P4, High precision P5, Precision P6, and Normal PN grades, while the random-matching type has Normal grade PC only.

Table 2 shows the accuracy standard for the preloaded assembly type while **Table 3** shows the accuracy standard for the random-matching types.

• **Tolerance of preloaded assembly**

Characteristics	Accuracy grade	Super precision P4	High precision P5	Precision grade P6	Normal grade PN
Mounting height H Variation of H (All ball slides on a set of rails)		± 10 5	± 15 7	± 20 15	± 40 25
Mounting width W_2 or W_3 Variation of W_2 or W_3 (All ball slides on reference rail)		± 15 7	± 20 10	± 30 20	± 50 30
Running parallelism of surface C to surface A Running parallelism of surface D to surface B		Shown in Table 1 and Fig. 2			

• **Tolerance of random-matching type: Normal grade PC**

Characteristics	Model No.	PE09, 12 and 15
Mounting height H		± 20
Variation of mounting height H		15 ^① 30 ^②
Mounting width W_2 or W_3		± 20
Variation of mounting width W_2 or W_3		20
Running parallelism of surface C to surface A Running parallelism of surface D to surface B		Shown in Table 1 and Fig. 2

Note: ① Variation on the same rail ② Variation on multiple rails

(3) Assembled accuracy

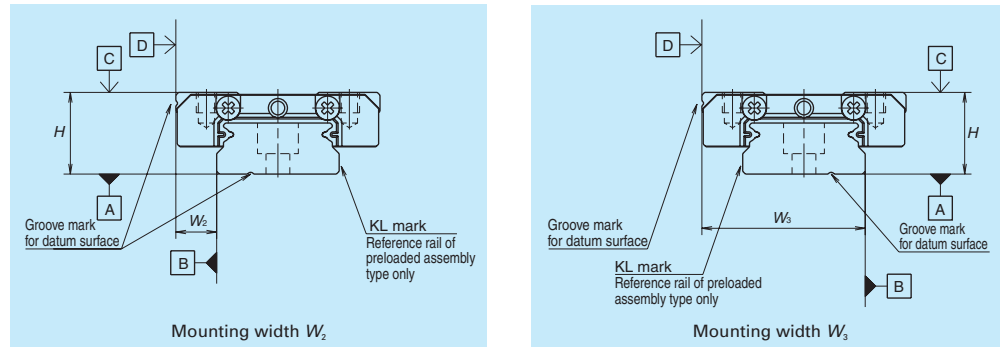

Fig. 2

(4) Preload and rigidity

We offer three levels of preload: Slight preload Z1 and Fine clearance Z0, along with random-matching type of Fine clearance ZT. Values for preload and rigidity of the preloaded assembly types are shown in **Table 4**. Rigidities are for the median of the preload range.

• **Preload and rigidity of preloaded assembly**

Model No.	Preload (N)	Rigidity (N/ μm)
	Slight preload (Z1)	Slight preload (Z1)
Standard type	PE05AR	0 – 28
	PE07TR	0 – 29
	PE09TR	0 – 37
	PE12AR	0 – 40
High-load type	PE15AR	0 – 49
	PE09UR	0 – 54
	PE12BR	0 – 59
PE15BR	0 – 75	114

Note: Clearance of Fine clearance Z0 is 0 to 3 μm . Therefore, preload is zero.

• **Clearance of random-matching type**

Model No.	Fine clearance ZT	
Standard type	PE09TR	3 or less
	PE12AR	
	PE15AR	
High-load type	PE09UR	5 or less
	PE12BR	
	PE15BR	

4. Maximum rail length

Table 6 shows the limitations of rail length.

However, the limitations vary by accuracy grades.

Series	Material	Size				
		05	07	09	12	15
PE	Stainless steel	150	600	800	1 000	1 200

Note: Rails can be butted if user requirement exceeds the rail length shown in the table. Please consult NSK.

5. Installation

(1) Permissible values of mounting error

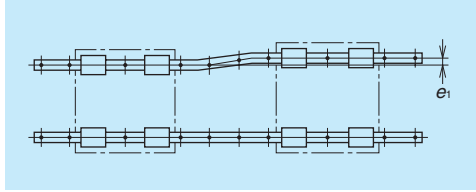

Fig. 3

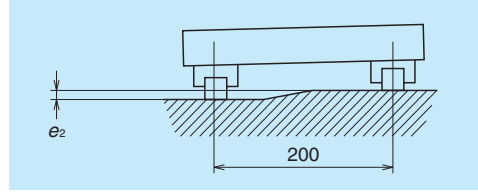

Fig. 4

Table 7

Unit: μm

Value	Preload	Model No.				
		PE05	PE07	PE09	PE12	PE15
Permissible values of parallelism in two rails e_1	Z0, ZT	10	12	15	18	22
	Z1	5	7	10	13	17
Permissible values of parallelism (height) in two rails e_2	Z0, ZT	50 $\mu\text{m}/200\text{ mm}$				
	Z1	35 $\mu\text{m}/200\text{ mm}$				

(2) Shoulder height of the mounting surface and corner radius r

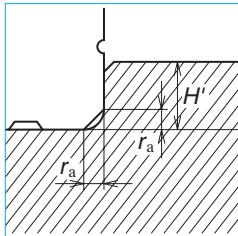

Fig. 5 Shoulder for the rail datum surface

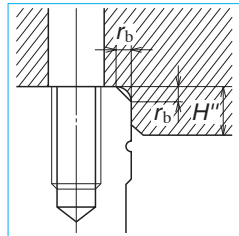

Fig. 6 Shoulder for the ball slide datum surface

Table 8

Unit: mm

Model No.	Corner radius (maximum)		Shoulder height	
	r_a	r_b	H'	H''^*
PE05	0.2	0.2	1.1	2.5
PE07	0.2	0.3	1.7	3
PE09	0.3	0.3	3.5	2.8
PE12	0.3	0.3	3.5	3.2
PE15	0.3	0.5	3.5	4.1

*) H'' is the minimum recommended value based on the dimension T in dimension table.

6. Lubrication accessory

Model of PE15 can select drive-in type grease fitting as an option.

For the model of PE05 to PE12, apply grease directly to the ball grooves of rail using a point nozzle.

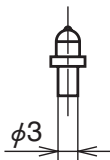

Drive-in type

7. Dust-proof components

(1) Standard specification

End seal: Provided to both ends of the ball slide as a standard feature.

Seal friction per standard ball slide is shown in **Table 9**.

Table 9 Seal friction per ball slide (maximum value)

Unit: N

Series	Size	05	07	09	12	15
PE		0.4	0.4	0.8	1	1.2

(2) NSK K1™ lubrication unit

Table 10 shows the dimension of linear guides equipped with the NSK K1 lubrication unit.

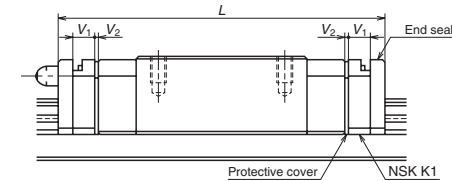

Table 10

Unit: mm

Model No.	Ball slide length	Ball slide model	Standard ball slide length	Ball slide length equipped with two NSK K1 L	Thickness of NSK K1, V_1	Thickness of protective cover, V_2
PE05	Standard	AR	24.1	28.9	2	0.4
PE07	Standard	TR	31.1	37.1	2.5	0.5
PE09	Standard	TR	39.8	46.8	3	0.5
	Long	UR	51.2	58.2		
PE12	Standard	AR	45	53	3.5	0.5
	Long	BR	60	68		
PE15	Standard	AR	56.6	66.2	4	0.8
	Long	BR	76	85.6		

Note: Ball slide length equipped with NSK K1 =

(Standard ball slide length) + (Thickness of NSK K1, $V_1 \times$ Number of NSK K1) +

(Thickness of the protective cover $V_2 \times 2$)

8. Reference number

Reference numbers shall be set to individual NSK linear guide when its specifications are finalized, and it is indicated on its specification drawing.

Please specify the reference number, except design serial number, to identify the product when ordering, requiring estimates, or inquiring about specifications from NSK.

(1) Reference number for preloaded assembly

PE 15 0470 ARK 2 - P5 1**

Series name	Preload code (See page A212.)
Size	Accuracy code (See Table 12.) 0: Z0, 1: Z1
Rail length (mm)	Design serial number
Ball slide shape code (See page A210.)	Added to the reference number.
Material/surface treatment code (See Table 11.) K: Stainless steel	Number of ball slides per rail

(2) Reference number for random-matching type

PAE 15 ARS -K

Random-matching ball slide series code PAE: PE Series random-matching ball slide	Option code -K: Equipped with NSK K1
Size	Material code S: Stainless steel
Ball slide shape code (See page A210.)	

P1E 15 0470 PKN - PC T**

Random-matching rail series code P1E: PE Series random-matching rail	Preload code (See page A212.) T: Fine clearance
Size	Accuracy code: PC PC: Normal grade is only available.
Rail length (mm)	Design serial number
Rail shape code R: PE09, 12. P: PE15	Added to the reference number.
Material/surface treatment code (See Table 11.)	*Butting rail specification N: Non-butting. L: Butting specification

*Please consult with NSK for butting rail specification.

Reference number coding for the assembly of random-matching type is the same as that of the preloaded assembly. However, only preload code of "Fine clearance T" is available (refer to page A212).

Table 11 Material/surface treatment code

Code	Description
K	Stainless steel
H	Stainless steel with surface treatment
Z	Other, special

Table 12 Accuracy code

Accuracy	Standard (Without NSK K1)	With NSK K1	With NSK K1 for food and medical equipment
Super precision grade	P4	K4	F4
High precision grade	P5	K5	F5
Precision grade	P6	K6	F6
Normal grade	PN	KN	FN
Normal grade (random-matching type)	PC	KC	FC

Note: Refer to pages A38 and A61 for NSK K1 lubrication unit.

9. Dimensions
PE-AR, TR (Standard type / Standard)
PE-UR, BR (High-load type / Long)

PE 15 0470 AR K 2 - PC T**

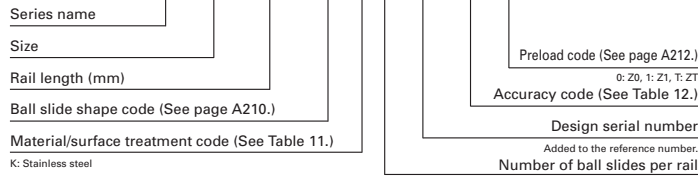

Front view

Side view

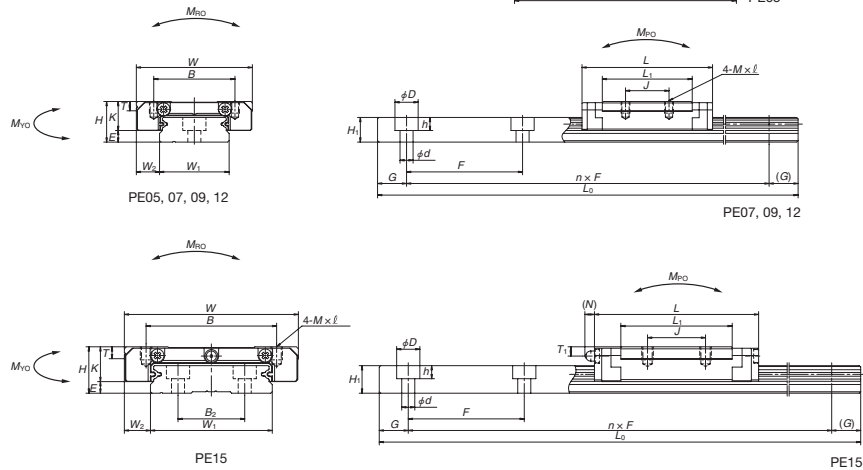

Model No.	Assembly			Ball slide										Width	Height		
	Height	E	W ₂	Width	Length	Mounting hole					Oil hole					W ₁	H ₁
						B	J	M × pitch × l	L ₁	K	T	Hole size	T ₁				
PE05AR	6.5	1.4	3.5	17	24.1	13	—	M2.5×0.45×1.5	16.4	5.1	2.5	φ 0.9	1.3	—	10	4	
PE07TR	9	2	5.5	25	31.1	19	10	M3×0.5×2.8	20.8	7	3	φ 1.9	1.9	—	14	5.2	
PE09TR	12	4	6	30	39.8	21	12	M3×0.5×3	26.6	8	2.8	φ 2	2.3	—	18	7.5	
PE09UR	12	4	6	30	51.2	23	24	M3×0.5×3	38	8	2.8	φ 2	2.3	—	18	7.5	
PE12AR	14	4	8	40	45	28	15	M3×0.5×4	31	10	3.2	φ 2.5	2.7	—	24	8.5	
PE12BR	14	4	8	40	60	28	15	M3×0.5×4	46	10	3.2	φ 2.5	2.7	—	24	8.5	
PE15AR	16	4	9	60	56.6	45	20	M4×0.7×4.5	38.4	12	4.1	φ 3	3.2	(3.3)	42	9.5	
PE15BR	16	4	9	60	76	45	35	M4×0.7×4.5	57.8	12	4.1	φ 3	3.2	(3.3)	42	9.5	

Notes: 1) Ball slide of PE05AR has only two mounting tap holes in the center.

Reference number for ball slide of random-matching type

PAE 15 AR S -K

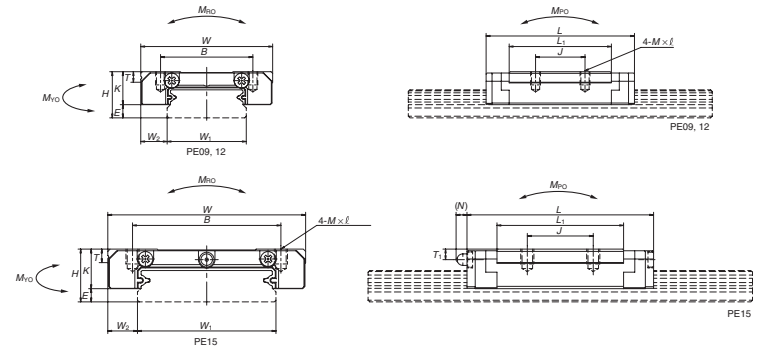
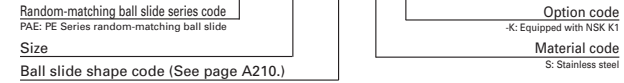

Reference number for rail of random-matching type

P1E15 0470 PKN - PC T**

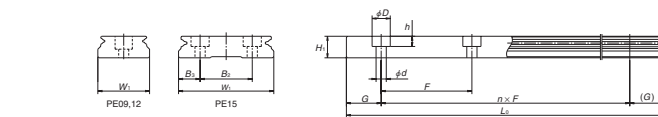
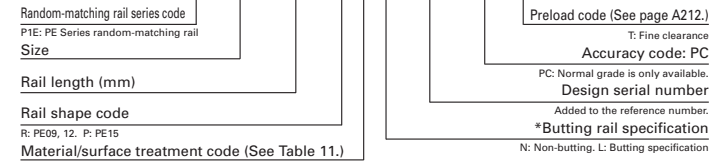

Rail					Basic load rating								Weight			
B ₂	Pitch	Mounting bolt hole	G	Maximum length	² Dynamic		C ₀	M _{RO}	Static moment (N·m)				Ball slide	Rail		
					[50km]	[100km]			C ₀	M _{PO}	M _{YO}				g	g/100 mm
											One slide	Two slides				
—	20	3×5×1.6	7.5	150	690	550	1 160	6.00	2.75	17.5	2.75	17.5	7	34		
—	30	3.5×6×3.2	10	600	1 580	1 260	2 350	16.7	7.20	46.0	7.20	46.0	19	55		
—	30	3.5×6×4.5	10	800	3 000	2 390	4 500	36.5	17.3	113	17.3	113	35	95		
—	40	4.5×8×4.5	15	1 000	4 000	3 150	6 700	54.5	37.5	210	37.5	210	50	95		
—	40	4.5×8×4.5	15	1 000	4 350	3 450	6 350	70.5	29.3	180	29.3	180	66	140		
23	40	4.5×8×4.5	15	1 200	7 600	6 050	10 400	207	59.0	370	59.0	370	140	275		
—	—	—	—	—	10 300	8 200	16 000	320	135	740	135	740	211	—		

2) The basic load rating comply with the ISO standard. (ISO 14728-1, 14728-2)

C₀: the basic dynamic load rating for 50 km rated fatigue life
 C₁₀₀: the basic dynamic load rating for 100 km rated fatigue life

3) To fix rail of PE05AR, use M2.5 × 0.45 cross-recessed pan head machine screw for precision instrument. (JCIS 10-70 No. 0 pan head machine screw No.3.)
 (JCIS: Japanese Camera Industrial Standard.)

A-5-2.4 LE Series (Miniature wide type)

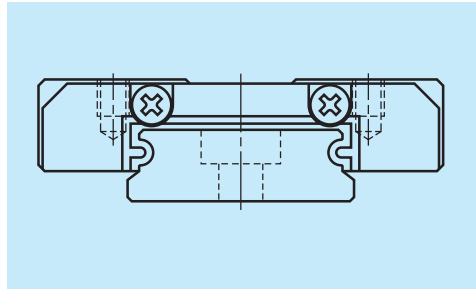

Fig. 1 LE Series

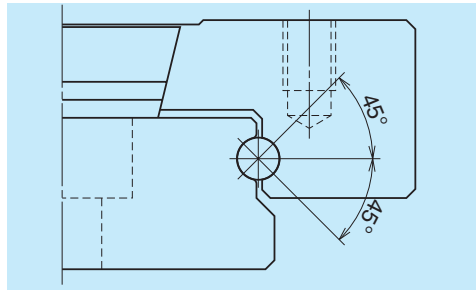

Fig. 2 Balls in contact

1. Features

(1) Ideal for use of single rail

The LE Series linear guides are miniature and wide rail type. Thanks to the wide rail, load carrying capacity is high against moment load from rolling direction.

(2) Equal load carrying capacity in vertical and lateral directions

Contact angle is set at 45 degrees, equally dispersing the load from vertical and lateral directions. This also provides equal rigidity in the two directions.

(3) Guides are super-thin.

Super-thin guides owe their design to the single ball groove on right and left sides (Gothic arch).

(4) High accuracy

Fixing the master rollers to the ball grooves is easy thanks to the Groove arch groove. This makes easy and accurate measuring of ball grooves.

(5) Stainless steel is standard.

Rails and ball slides are made of martensitic stainless steel.

(6) Ball retainer is available in some series.

Some series come with a ball retainer (ball slide shape: AR and TR). Balls are retained in the retainer and do not fall out when a ball slide is withdrawn from the rail (random-matching type ball slides come with a ball retainer).

(7) Fast delivery

Random matching of rails and ball slides are available. (LE09 to LE15)

2. Ball slide shape

Ball slide Model	Shape/installation method	Type (Upper row, Rating: Lower row, Ball slide length)		
		Medium-load type Short	Standard type Standard	High-load type Long
AL TL AR TR BL UL CL SL		CL, SL	AL, TL, AR, TR	BL, UL

Specification	Detail	Type		
Mounting hole	Normal	CL*	AL, AR	BL*
	Large	SL*	TL, TR	UL*
Ball retainer	Without	CL, SL	AL, TL	BL, UL
	With	—	AR, TR	—

* Only applicable to LE09

3. Accuracy and preload

(1) Running parallelism of ball slide

Table 1

Unit: μm

Rail length (mm)	Preloaded assembly type (not random matching)			Random-matching type
	High precision P5	Precision grade P6	Normal grade PN	Normal grade PC
over				
or less				
– 50	2	4.5	6	6
50 – 80	3	5	6	6
80 – 125	3.5	5.5	6.5	6.5
125 – 200	4	6	7	7
200 – 250	5	7	8	8
250 – 315	5	8	9	9
315 – 400	6	9	11	11
400 – 500	6	10	12	12
500 – 630	7	12	14	14
630 – 800	8	14	16	16
800 – 1 000	9	16	18	18
1 000 – 1 250	10	17	20	20

(2) Accuracy standard

The preloaded assembly type has three accuracy grades; High precision P5, Precision P6, and Normal PN grades, while the random-matching type has Normal grade PC only.

Table 2 shows the accuracy standard for the preloaded assembly type while **Table 3** shows the accuracy standard for the random-matching type.

• Tolerance of preloaded assembly

Characteristics	Accuracy grade		
	High precision P5	Precision P6	Normal grade PN
Mounting height H	± 15	± 20	± 40
Variation of H (All ball slides on a set of rails)	7	15	25
Mounting width W_2 or W_3 Variation of W_2 or W_3 (All ball slides on reference rail)	± 20 10	± 30 20	± 50 30
Running parallelism of surface C to surface A Running parallelism of surface D to surface B	Refer to Table 1 and Fig. 3		

• Tolerance of random-matching type: Normal grade PC

Characteristics	Accuracy grade
Mounting height H	± 20
Variation of mounting height H	40
Mounting width W_2 or W_3	± 20
Variation of mounting width W_2 or W_3	40
Running parallelism of surface C to surface A Running parallelism of surface D to surface B	Refer to Table 1 and Fig. 3

(3) Assembled accuracy

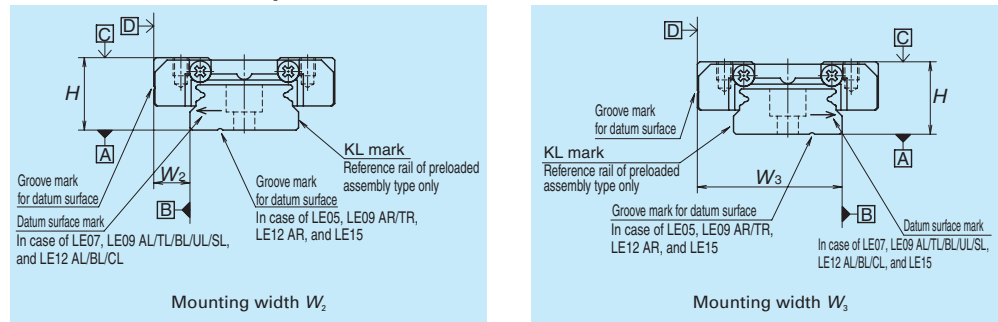

Fig. 3

(4) Preload and rigidity

We offer three levels of preload: Slight preload Z1 and Fine clearance Z0 for the preloaded assembly type, along with Fine clearance ZT for the random-matching type. Values for preload and rigidity of the preloaded assembly type are shown in **Table 4**. Rigidities are for the median of the preload range.

• Preload and rigidity of preloaded assembly

Model No.	Preload (N)	Rigidity (N/ μm)
	Slight preload (Z1)	Slight preload (Z1)
Standard type	LE05 AL	0 – 23
	LE07 TL	0 – 29
	LE09 AL, TL, AR, TR	0 – 37
	LE12 AL, AR	0 – 40
Medium-load type	LE15 AL, AR	0 – 49
	LE05 CL	0 – 18
	LE07 SL	0 – 16
	LE09 CL, SL	0 – 21
High-load type	LE12 CL	0 – 23
	LE15 CL	0 – 29
	LE07 UL	0 – 43
	LE09 BL, UL	0 – 54
	LE12 BL	0 – 59
LE15 BL	0 – 75	
		114

Note: The clearance of Fine clearance Z0 is 0 to 3 μm . Therefore, preload is zero. However, the clearance of the Z0 of PN grade is 3 to 10 μm .

• Clearance of random-matching type

Model No.	Fine clearance ZT
LE09	0 – 15
LE12	
LE15	

4. Maximum rail length

Table 6 shows the limitations of rail length. The limitations vary by accuracy grades.

Series	Size	Material				
		05	07	09	12	15
LE	Stainless steel	150	600	800	1 000	1 200

Note: Rails can be butted if user requirement exceeds the rail length shown in the table. Please consult NSK.

5. Installation

(1) Permissible values of mounting error

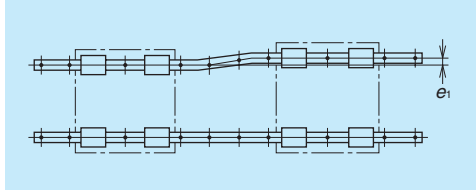

Fig. 4

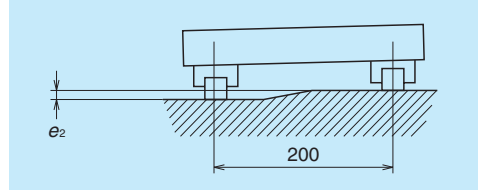

Fig. 5

Table 7

Unit: μm

Value	Preload	Model No.				
		LE05	LE07	LE09	LE12	LE15
Permissible values of parallelism in two rails e_1	Z0, ZT	10	12	15	18	22
	Z1	5	7	10	13	17
Permissible values of parallelism (height) in two rails e_2	Z0, ZT	50 $\mu\text{m}/200\text{ mm}$				
	Z1	35 $\mu\text{m}/200\text{ mm}$				

(2) Shoulder height of the mounting surface and corner radius r

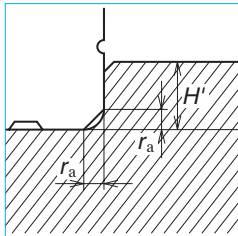

Fig. 6 Shoulder for the rail datum surface

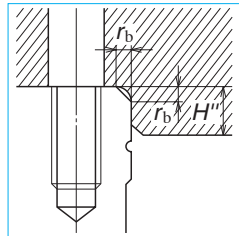

Fig. 7 Shoulder for the ball slide datum surface

Table 8

Unit: mm

Model No.	Corner radius (maximum)		Shoulder height	
	r_a	r_b	H'	H''
LE05	0.2	0.2	1.1	2
LE07	0.2	0.3	1.7	3
LE09	0.3	0.3	3.5	3
LE12	0.3	0.3	3.5	4
LE15	0.3	0.5	3.5	5

6. Lubrication accessories

Model of LE15AR can select drive-in type grease fitting as option.

There is no standard grease fitting for LE05 to LE12.

For the models of LE05 to LE15 except for LE15AR, apply grease directly to the ball grooves of rail, using a point nozzle.

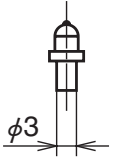

Drive-in type

7. Dust-proof components

(1) Standard specification

End seal: Provided to both ends of the ball slide as a standard feature.

• Seal friction per standard ball slide is shown in Table 9.

Table 9 Seal friction per ball slide (maximum value)

Unit: N

Series	Size	05	07	09	12	15
LE		0.4	0.4	0.8	1.0	1.2

(2) NSK K1™ lubrication unit

The installed dimensions of NSK K1 lubrication unit are shown in Table 10.

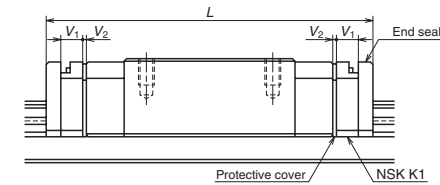

Table 10

Unit: mm

Model No.	Ball slide length	Ball slide model	Standard ball slide length	Ball slide length installed with two NSK K1 L	Per NSK K1 thickness V_1	Protective cover thickness V_2
LE07	Standard	TL	31	37	2.5	0.5
	Long	UL	42	48		
	Short	SL	22.4	28.4		
LE09	Standard	AL, TL	39	46	3.0	0.5
	Standard	AR, TR	39.8	46.8		
	Long	BL, UL	50.4	57.4		
LE12	Standard	CL, SL	26.4	33.4	3.5	0.5
	Standard	AL	44	52		
	Standard	AR	45	53		
LE15	Long	BL	59	67	4.0	0.8
	Short	CL	30.5	38.5		
	Standard	AL	55.0	64.6		
LE15	Standard	AR	56.6	66.2	4.0	0.8
	Long	BL	74.4	84		
	Short	CL	41.4	51		

Note: Ball slide length equipped with NSK K1 =

(Standard ball slide length) + (Thickness of NSK K1, $V_1 \times$ Number of NSK K1) + (Thickness of the protective cover $V_2 \times 2$)

8. Reference number

Reference numbers shall be set to individual NSK linear guide when its specifications are finalized, and it is indicated on its specification drawing.

Please specify the reference number, except design serial number, to identify the product when ordering, requiring estimates, or inquiring about specifications from NSK.

(1) Reference number for preloaded assembly

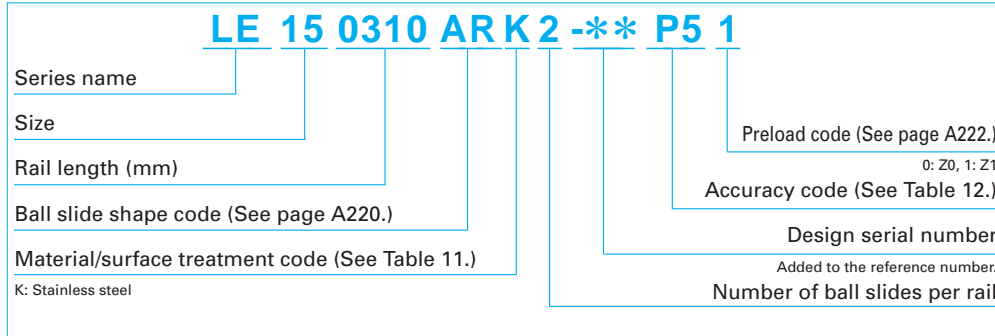

(2) Reference number for random-matching type

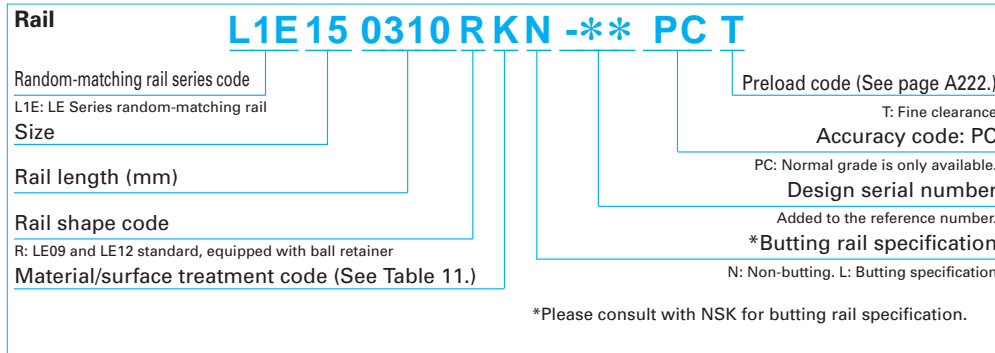
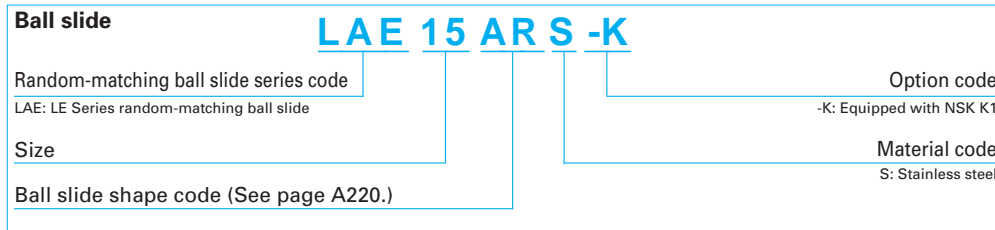

The reference number coding for the assembly of random-matching type is the same as that of the preloaded assembly. However, only the preload code of "Fine clearance T" is available (refer to page A222).

Table 11 Material/surface treatment code

Code	Description
K	Stainless steel
H	Stainless steel with surface treatment
Z	Other, special

Table 12 Accuracy code

Accuracy	Standard (Without NSK K1)	With NSK K1
High precision grade	P5	K5
Precision grade	P6	K6
Normal grade	PN	KN
Normal grade (random-matching type)	PC	KC

Note: Refer to page A38 for NSK K1 lubrication unit.

9. Dimensions

- LE-AL (Standard type / Standard)
- LE-TL (Standard type / Standard, large mounting hole)
- LE-AR (Standard type / Standard, with ball retainer)
- LE-TR (Standard type / Standard, large mounting hole, with ball retainer)

LE 15 0310 AR K 2 - PC T**

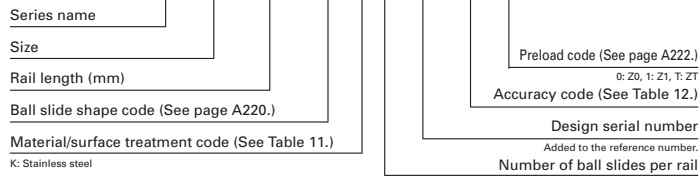

Front view

Side view

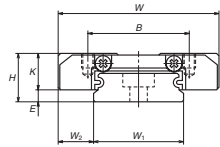

LE05, 07, 09, 12

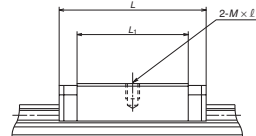

LE05

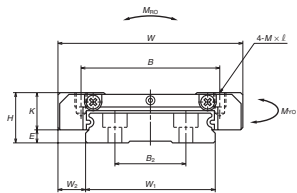

LE15

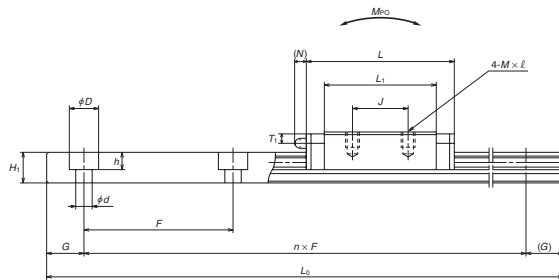

LE07, 09, 12, 15

- Reference number for ball slide of random-matching type
- Random matching with retainer: LAE09AR/TR, LAE12AR, LAE15AR
- LAE-AR (With ball retainer)
- LAE-TR (Large mounting hole with ball retainer)

LAE 15 AR S -K

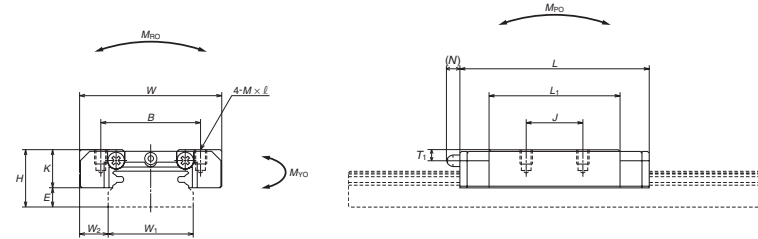
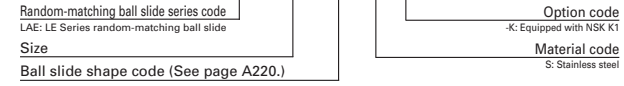

Reference number for rail of random-matching type

Rail L1E15 0310 RKN - PC T**

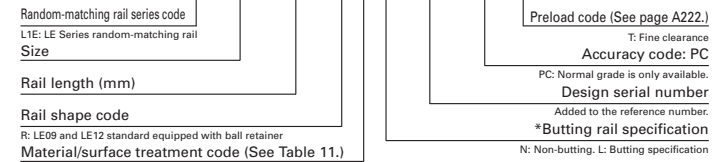

LE09, 12

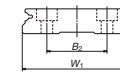

LE15

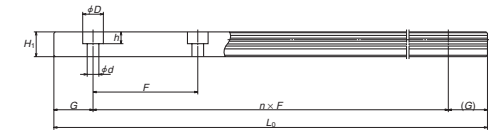

Model No.	Assembly			Ball slide							Grease fitting				Pitch	
	Height	Width	Length	Mounting hole				Hole size	Width	Height	Pitch					
				B	J	M x pitch x l	L1									
LE05AL	6.5	1.4	3.5	17	24	13	—	M2.5x0.45x2	17	5.1	—	—	10	4	—	20
LE07TL	9	2	5.5	25	31	19	10	M3x0.5x3	21.2	7	—	—	14	5.2	—	30
LE09AL	12	4	6	30	39	21	12	M2.6x0.45x3 M3x0.5x3	27.6	8	—	—	18	7.5	—	30
LE09AR																
LE09TR	12	4	6	30	39.8	21	12	M2.6x0.45x3 M3x0.5x3	27.6	8	—	—	18	7.5	—	30
LE12AL	14	4	8	40	44	28	15	M3x0.5x4	31	10	—	—	24	8.5	—	40
LE12AR																
LE15AL	16	4	9	60	55	45	20	M4x0.7x4.5	38.4	12	—	—	42	9.5	23	40
LE15AR																

Notes: 1) Ball slide of LE05 has only two mounting tap holes.

Rail	Mounting bolt hole	G	Max. length	Basic load rating								Weight	
				Dynamic		Static	Static moment (N-m)				Ball slide	Rail	
				[50km]	[100km]		C0	MRO	MPO				MYO
d x D x h	(reference)	L0max	C50(N)	C100(N)	(N)	One slide	Two slides	One slide	Two slides	(g)	(g/100 mm)		
3x5x1.6	7.5	150	725	575	1 110	5.65	2.58	16.9	2.58	16.9	11	34	
3.5x6x3.2	10	600	1 580	1 260	2 350	16.7	7.20	46.0	7.20	46.0	25	55	
3.5x6x4.5	10	800	3 000	2 400	4 500	36.5	17.3	110	17.3	110	40	95	
3.5x6x4.5	10	800	3 000	2 400	4 500	36.5	17.3	113	17.3	113	40	95	
4.5x8x4.5	15	1 000	4 350	3 450	6 350	70.5	29.3	175	29.3	175	75	140	
4.5x8x4.5	15	1 200	7 600	6 050	10 400	207	59.0	360	59.0	360	150	275	

- 2) The basic load rating comply with the ISO standard. (ISO 14728-1, 14728-2)
C50: the basic dynamic load rating for 50 km rated fatigue life C100: the basic dynamic load rating for 100 km rated fatigue life
- 3) For fixing a rail of LE05AL, use M2.5 x 0.45 cross-recessed pan head machine screw for precision instruments.
(JICIS 10-70: No.0 pan head machine screw No.3) (JICIS: Japanese Camera Industrial Standard)

LE-BL (High-load type / Long)
LE-UL (High-load type / Long, large mounting hole)

LE 15 0310 BL K 2 - P5 1**

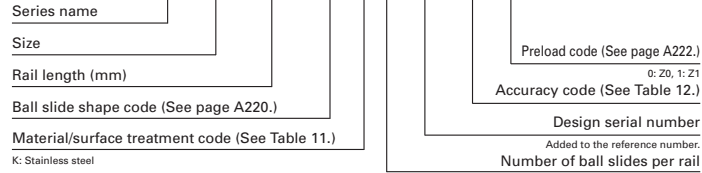

Front view

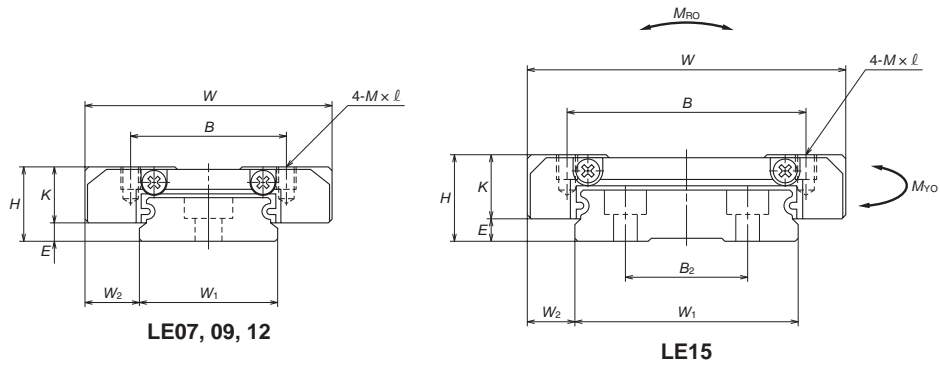

Side view

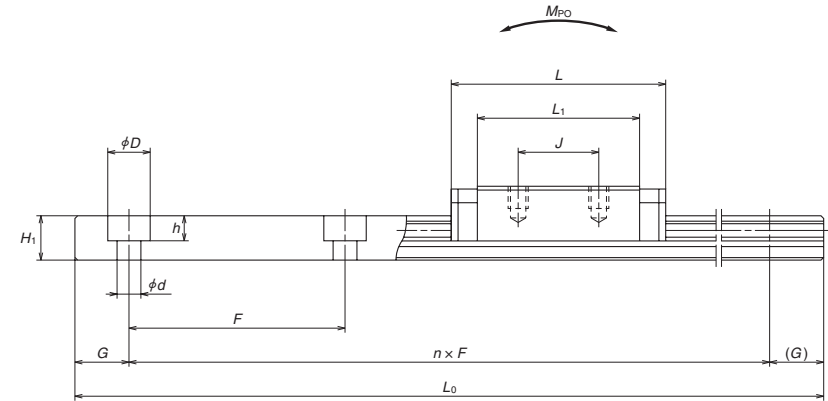

Model No.	Assembly			Ball slide							Width	Height	Pitch	
	Height	Width	Length	Mounting hole				L ₁	K	B ₂				F
				B	J	M × pitch × l	L ₁							
LE07UL	9	25	42	19	19	M3×0.5×3	32.2	7	14	5.2	—	30		
LE09BL LE09UL	12	30	50.4	23	24	M2.6×0.45×3 M3×0.5×3	39	8	18	7.5	—	30		
LE12BL	14	40	59	28	28	M3×0.5×4	46	10	24	8.5	—	40		
LE15BL	16	60	74.4	45	35	M4×0.7×4.5	57.8	12	42	9.5	23	40		

Unit: mm

Rail			Basic load rating							Weight			
Mounting bolt hole	G	Max. length	¹⁾ Dynamic		Static	C ₀	Static moment (N·m)				Ball slide	Rail	
			[50km]	[100km]			M _{PO}		M _{YO}				
			d × D × h	(reference)	L _{0max}	C ₅₀ (N)	C ₁₀₀ (N)	(N)	M _{PO}	M _{YO}	One slide	Two slides	One slide
3.5×6×3.2	10	600	2 180	1 730	3 700	26.4	17.3	94.5	17.3	94.5	39	55	
3.5×6×4.5	10	800	4 000	3 150	6 700	54.5	37.5	206	37.5	206	58	95	
4.5×8×4.5	15	1 000	5 800	4 600	9 550	106	63.5	340	63.5	340	115	140	
4.5×8×4.5	15	1 200	10 300	8 200	16 000	320	135	725	135	725	235	275	

Note: 1) The basic load rating comply with the ISO standard. (ISO 14728-1, 14728-2)
 C₅₀: the basic dynamic load rating for 50 km rated fatigue life
 C₁₀₀: the basic dynamic load rating for 100 km rated fatigue life

LE-CL (Medium-load type / Short)
LE-SL (Medium-load type / Short, large mounting hole)

LE 15 0310 CL K 2 - P5 1**

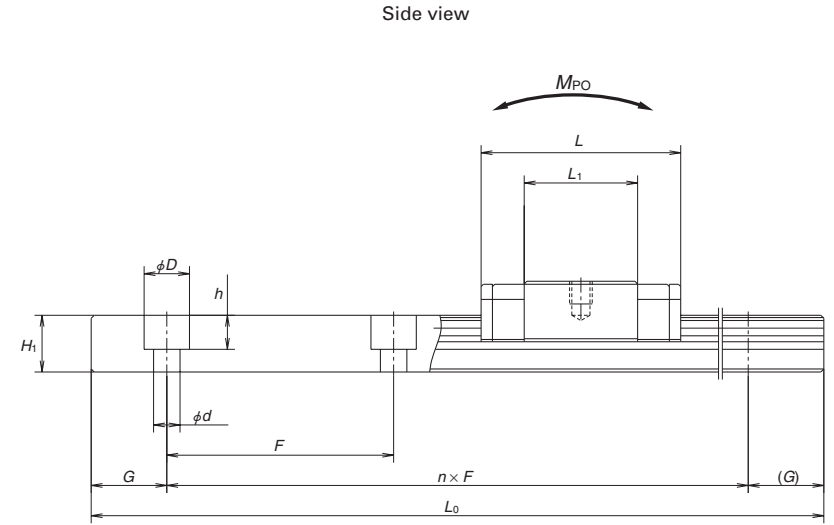
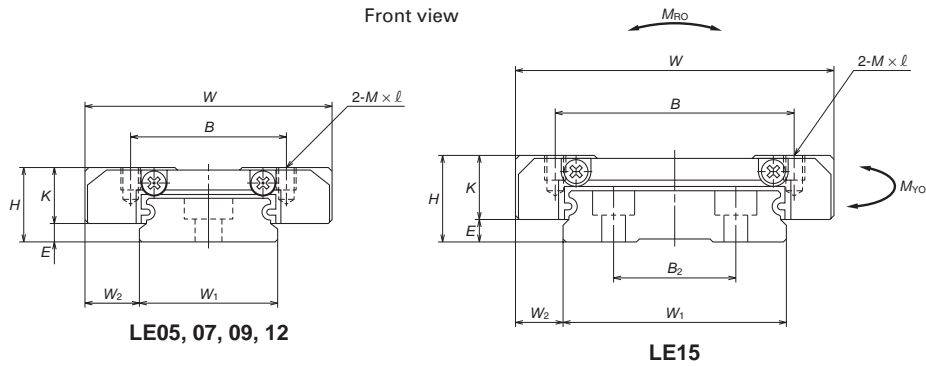
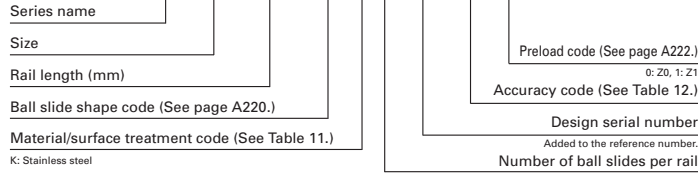

Model No.	Assembly			Ball slide										
	Height H	E	W ₂	Width W	Length L	Mounting hole					Width W ₁	Height H ₁	Pitch F	
						B	J	M × pitch × ℓ	L ₁	K				
LE05CL	6.5	1.4	3.5	17	20	13	—	M2.5×0.45×2	13	5.1	10	4	—	20
LE07SL	9	2	5.5	25	22.4	19	—	M3×0.5×3	12.6	7	14	5.2	—	30
LE09CL LE09SL	12	4	6	30	26.4	21	—	M2.6×0.45×3 M3×0.5×3	15	8	18	7.5	—	30
LE12CL	14	4	8	40	30.5	28	—	M3×0.5×4	17.5	10	24	8.5	—	40
LE15CL	16	4	9	60	41.4	45	—	M4×0.7×4.5	24.8	12	42	9.5	23	40

Notes: 1) Ball slide of CL and SL types have only two mounting tap holes in the center.

Rail		Basic load rating									Weight	
Mounting bolt hole d × D × h	G (reference)	Max. length L _{0max}	² Dynamic		Static C ₀ (N)	Static moment (N-m)				Ball slide (g)	Rail (g/100 mm)	
			[50km] C ₅₀ (N)	[100km] C ₁₀₀ (N)		M _{PO}		M _{VO}				
							One slide		Two slides			
3×5×1.6	7.5	150	595	470	835	4.25	1.51	10.0	1.51	10.0	8	34
3.5×6×3.2	10	600	980	775	1 170	8.35	2.01	18.5	2.01	18.5	17	55
3.5×6×4.5	10	800	1 860	1 480	2 240	18.2	4.85	41.0	4.85	41.0	25	95
4.5×8×4.5	15	1 000	2 700	2 140	3 150	35.0	8.15	67.0	8.15	67.0	50	140
4.5×8×4.5	15	1 200	5 000	3 950	5 650	113	19.4	162	19.4	162	110	275

2) The basic load rating comply with the ISO standard. (ISO 14728-1, 14728-2)

C₅₀: the basic dynamic load rating for 50 km rated fatigue life C₁₀₀: the basic dynamic load rating for 100 km rated fatigue life

3) For fixing a rail of LE05CL, use cross-recessed pan head machine screw for precision instruments M2.5 × 0.45 (JIS 10-70: Japan Camera Industry Association, No.0, class 3).

A-5-2.5 Miniature LH Series

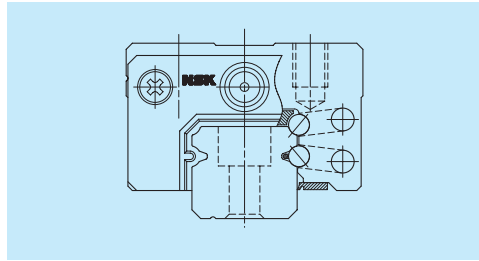
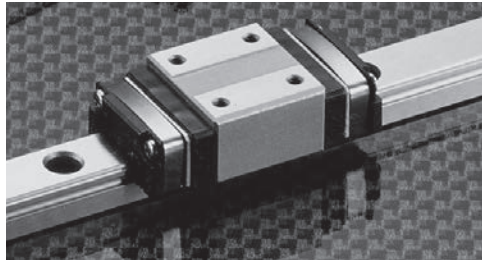

Fig. 1 LH Series

1. Features

(1) High self-aligning capability (rolling direction)

Same as the DF combination in angular contact bearings, self-aligning capability is high because the cross point of the contact lines of balls and grooves comes inside, and thus reducing moment rigidity.

This increases the capacity to absorb errors in installation.

(2) High load carrying capacity to vertical direction

The contact angle is set at 50 degrees, and thus increasing load carrying capacity as well as rigidity in vertical direction.

(3) High resistance against impact load

The bottom ball groove is formed in Gothic arch and the center of the top and bottom grooves are offset as shown in Fig. 2. The vertical load is generally carried by the top ball rows, where balls are contacting at two points. Because of this design, the bottom ball rows will carry load when a large impact load is applied vertically as shown in Fig. 3. This assures high resistance to the impact load.

(4) High accuracy

As showing in Fig. 4, fixing the master rollers to the ball grooves is easy thanks to the Gothic arch groove. This makes easy and accurate measuring of ball grooves.

(5) High corrosion resistance

High corrosion-resistant martensite stainless steel is incorporated as a standard feature to provides excellent corrosion resistance.

(6) Easy to handle

Safety design includes a retainer that prevents steel balls from dropping out of the ball slide even when the slide is removed from the rail. (LH10-12)

(7) Long-term maintenance-free

Superb features of NSK K1 Lubrication unit realize a long-term, maintenance-free operation.

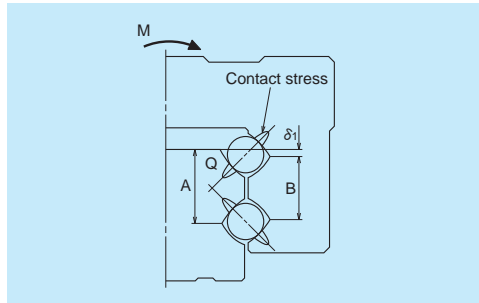

Fig. 2 Enlarged illustration of the offset Gothic arch groove

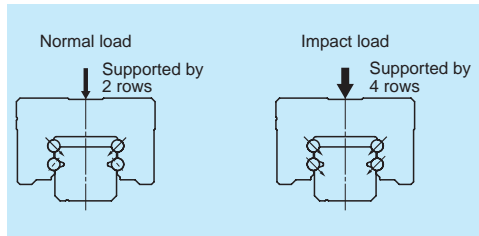

Fig. 3 When load is applied

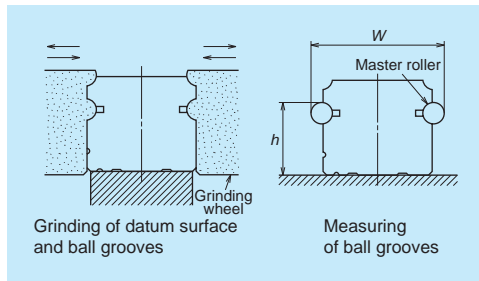

Fig. 4 Rail grinding and measuring

2. Ball slide shape

Ball slide Model	Shape/installation method	Type
AN		AN

3. Accuracy and preload

(1) Running parallelism of ball slide

Table 1 Unit: μm

Rail length (mm)	Preloaded assembly			
	Super precision P4	High precision P5	Precision grade P6	Normal grade PN
over 50	2	2	4.5	6
50 - 80	2	3	5	6
80 - 125	2	3.5	5.5	6.5
125 - 200	2	4	6	7
200 - 250	2.5	5	7	8
250 - 315	2.5	5	8	9
315 - 400	3	6	9	11
400 - 500	3	6	10	12
500 - 630	3.5	7	12	14
630 - 800	4.5	8	14	16

(2) Accuracy standard

The preloaded assembly has four accuracy grades; Super precision P4, High precision P5, Precision P6 and Normal PN grades.

• Tolerance of preloaded assembly

Table 2 Unit: μm

Characteristics	Super precision P4	High precision P5	Precision grade P6	Normal grade PN
Mounting height H	± 10	± 20	± 40	± 80
Variation of H (All ball slides on a set of rails)	3	5	7	15
Mounting width W_2 or W_3	± 10	± 15	± 25	± 50
Variation of W_2 or W_3 (All ball slides on reference rail)	5	7	10	20
Running parallelism of surface C to surface A Running parallelism of surface D to surface B	Shown in Table 1, Fig. 5			

(3) Combinations of accuracy and preload

Table 3

		Accuracy grade			
		Super precision	High precision	Precision grade	Normal grade
Without NSK K1 lubrication unit		P4	P5	P6	PN
With NSK K1 lubrication unit		K4	K5	K6	KN
With NSK K1 for food and medical equipment		F4	F5	F6	FN
Preload	Fine clearance Z0	○	○	○	○
	Slight preload Z1	○	○	○	○

(4) Assembled accuracy

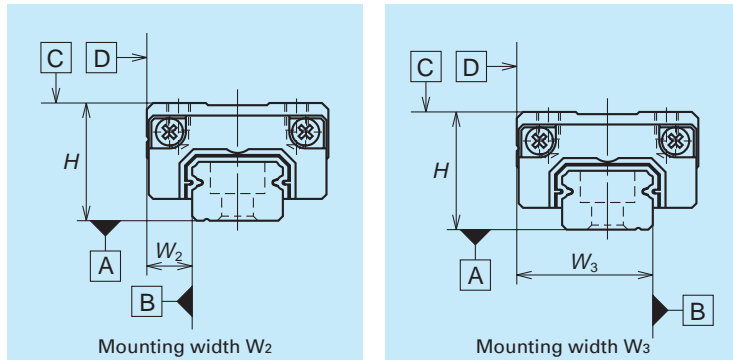

Fig. 5

(5) Preload and rigidity

We offer two levels of preload: Slight preload Z1 and Fine clearance Z0.

• Preload and rigidity of preloaded assembly

Table 4

Model No.	Preload (N)	Rigidity (N/μm)	
		Vertical direction	Lateral direction
		Slight preload Z1	Slight preload Z1
LH08AN	5	33	23
LH10AN	9	44	31
LH12AN	22	68	47

Note: Clearance for Fine clearance Z0 is 0 to 3μm. Therefore, preload is zero. However, Z0 of PN grade is 0 to 5μm.

4. Maximum rail length

Table 5 shows the limitations of rail length (maximum length). However, the limitations vary by accuracy grades.

Table 5 Length limitations of rails

Unit: mm

Series	Material	Size		
		08	10	12
LH	Stainless steel	375	600	800

Note: Rails can be butted if user requirement exceeds the rail length shown in the table. Please consult NSK.

5. Installation

(1) Permissible values of mounting error

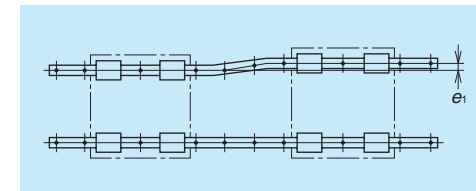

Fig. 6

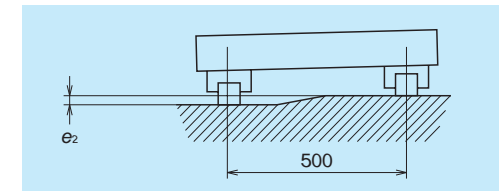

Fig. 7

Table 6

Unit: μm

Value	Preload	Model No.		
		LH08	LH10	LH12
Permissible values of parallelism in two rails e_1	Z0	9	12	19
	Z1	8	11	18
Permissible values of parallelism (height) in two rails e_2	Z0	375μm/500mm		
	Z1	330μm/500mm		

(2) Shoulder height of the mounting surface and corner radius r

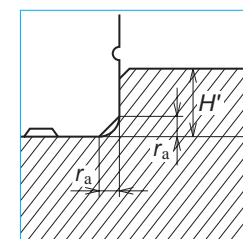

Fig. 8 Shoulder for the rail datum surface

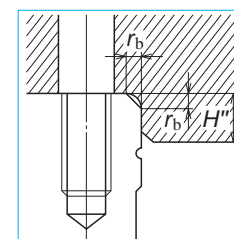

Fig. 9 Shoulder for the ball slide datum surface

Table 7

Unit: mm

Model No.	Corner radius (maximum)		Shoulder height	
	r_a	r_b	H'	H''
LH08	0.3	0.5	1.8	3
LH10	0.3	0.5	2.1	4
LH12	0.5	0.5	2.7	4

6. Lubrication accessory

Model of LH12 can select drive-in type grease fitting as an option.

For the models of LH08 to LH10, apply grease directly to the ball grooves of rail using a point nozzle.

Grease fitting

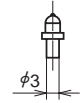

Drive-in type

Fig. 10

7. Dust-proof components

(1) Standard specification

The LH Series can be readily used as they have a dust protection means for normal conditions. As the standard equipment, the ball slides have an end seal on both ends, and bottom seals at the bottom.

However, the bottom seals are not used to LH08 and 10.

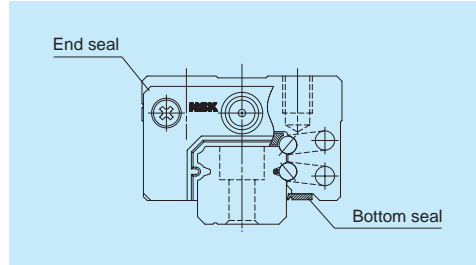

Fig. 11

Table 8 Seal friction per ball slide (maximum value)

		Unit: N		
Series	Size	08	10	12
LH		0.5	1	1.5

(2) NSK K1™ lubrication unit

Table 9 shows the dimension of linear guides equipped with the NSK K1 lubrication unit

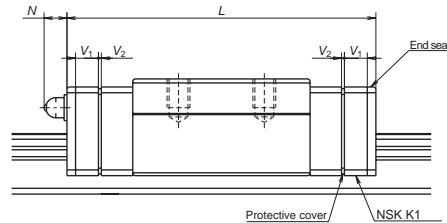

Table 9

Unit: mm

Model No.	Ball slide length	Ball slide model	Standard ball slide length	Ball slide length installed with two NSK K1 L	Per NSK K1 thickness V ₁	Protective cover thickness V ₂	Protruding area of the grease fitting N
LH08	Standard	AN	24	31	3	0.5	—
LH10	Standard	AN	31	40	4	0.5	—
LH12	Standard	AN	45	54	4	0.5	(4)

Notes: 1) NSK K1 for food and medical equipment are available for LH12.

2) Ball slide length equipped with NSK K1 = (Standard ball slide length) + (Thickness of NSK K1, V₁ × Number of NSK K1) + (Thickness of the protective cover, V₂ × 2)

(3) Cap to plug the rail mounting bolt hole

Table 10 Caps to plug rail bolt hole

Model No.	Bolt to secure rail	Cap reference No.	Quantity /case
LH12	M3	LG-CAP/M3	20

8. Reference number

Reference numbers shall be set to individual NSK linear guide when its specifications are finalized, and it is indicated on its specification drawing.

Please specify the reference number, except design serial number, to identify the product when ordering, requiring estimates, or inquiring about specifications from NSK.

(1) Reference number for preloaded assembly

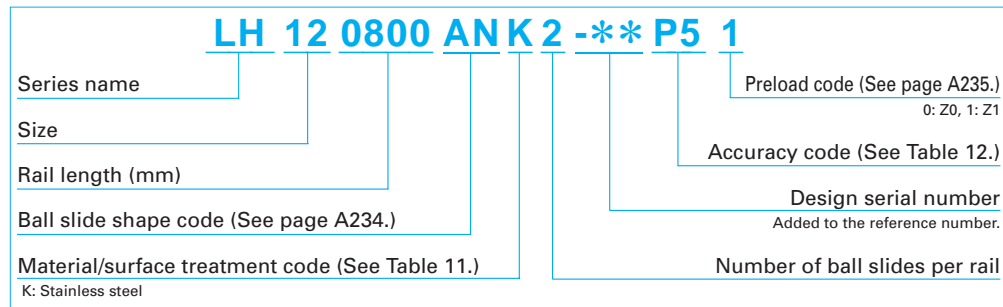

Table 11 Material/surface treatment code

Code	Description
K	Stainless steel
H	Stainless steel with surface treatment
Z	Other, special

Table 12 Accuracy code

Accuracy	Standard (Without NSK K1)	With NSK K1	With NSK K1 for food and medical equipment
Super precision grade	P4	K4	F4
High precision grade	P5	K5	F5
Precision grade	P6	K6	F6
Normal grade	PN	KN	FN

Note: Refer to pages A38 and A61 for NSK K1 lubrication unit.

9. Dimensions

LH 12 0800 AN K 2 - P5 1**

Series name	Preload code (See page A235.)
Size	0: Z0, 1: Z1
Rail length (mm)	Accuracy code (See Table 12.)
Ball slide shape code (See page A234.)	Design serial number Added to the reference number.
Material/surface treatment code (See Table 11.)	Number of ball slides per rail

K: Stainless steel

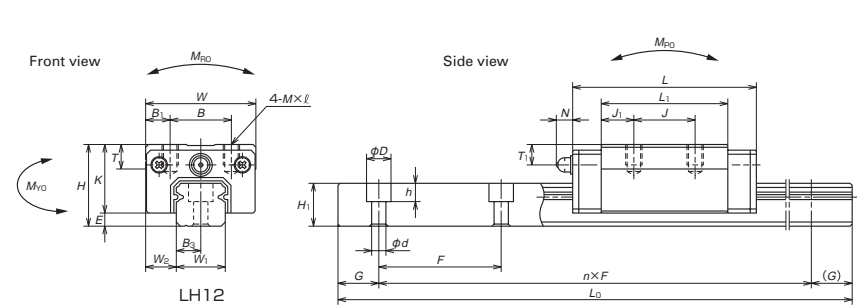
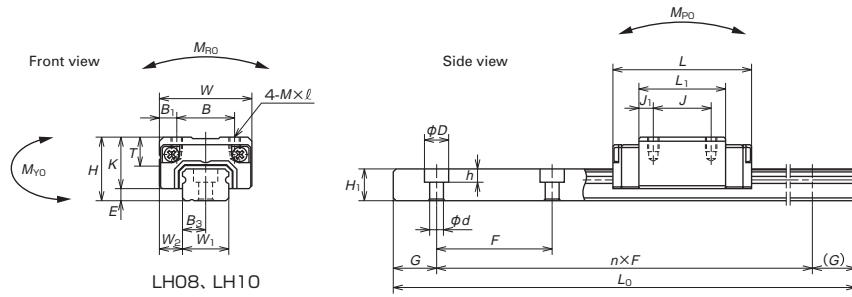

Model No.	Assembly			Ball slide										Width	Height	
	Height	E	W ₂	Width	Length	Mounting hole				Grease fitting			W ₁			H ₁
						B	J	M × pitch × l	L ₁	K	T	Hole size				
LH08AN	11	2.1	4	16	24	10	10	M2×0.4×2.5	15	8.9	—	—	—	—	8	5.5
LH10AN	13	2.4	5	20	31	13	12	M2.6×0.45×3	20.2	10.6	6	—	—	—	10	6.5
LH12AN	20	3.2	7.5	27	45	15	15	M4×0.7×5	31	16.8	6	φ3	5	4	12	10.5

Notes: 1) LH08 does not have a ball retainer. Be aware that balls fall out when the ball slide is withdrawn from the rail.

Unit: mm

Rail		Basic load rating									Weight		
Pitch	Mounting bolt hole	G	Max. length	²⁾ Dynamic		Static	C ₀	Static moment (N·m)				Ball slide	Rail
				[50km]	[100km]			M _{R0}	M _{P0}		M _{V0}		
F	d × D × h	(reference)	L _{0max}	C ₅₀ (N)	C ₁₀₀ (N)	(N)	M _{R0}	One slide	Two slides	One slide	Two slides	(g)	(g/100 mm)
20	2.4×4.2×2.3	7.5	375	1 240	985	2 630	7.25	4.55	32.5	3.8	27.2	13	31
25	3.5×6×3.5	10	600	2 250	1 790	4 500	16.2	10.5	73.0	8.8	61.0	26	44
40	3.5×6×4.5	15	800	5 650	4 500	11 300	47.5	41.5	254	35	214	82	88

2) The basic load rating comply with the ISO standard. (ISO 14728-1, 14728-2)

C₅₀: the basic dynamic load rating for 50 km rated fatigue life C₁₀₀: the basic dynamic load rating for 100 km rated fatigue life

A-5-2.6 LL Series

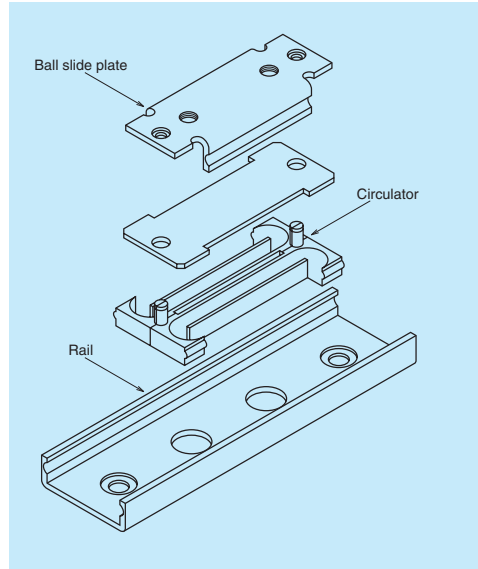
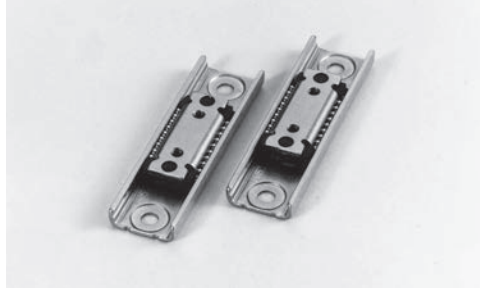

Fig. 1 LL Series structure

1. Features

(1) Super light-weight

This compact guide has a single ball groove on both right and left sides (Gothic arch). Rails and ball slides are made of stainless steel plate, therefore they are lightweight.

(2) Compact

The ball groove is made outside the ball slide to reduce overall size and to obtain high speed.

(3) High corrosion resistance

High corrosion resistant martensitic stainless steel is used as standard material.

2. Ball slide model

Ball slide model	Shape/installation method
PL	

3. Accuracy and preload

(1) Accuracy standard

The LL Series has a Normal grade PN as the accuracy grade.

Table 1 shows the tolerance.

Table 1 Tolerance of Normal grade (PN)

Characteristic	Model No.	Unit: μm
Mounting height	LL15	± 20
Running parallelism of surface C to surface A		20
Running parallelism of surface D to surface B		(See Fig. 2.)

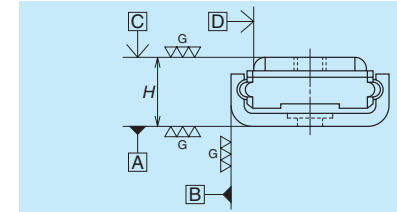

Fig. 2 Standard LL

(2) Preload

We offer clearance for the LL Series.

Table 2 shows the specification of clearance.

Table 2 Radial clearance

Model No.	Clearance	Unit: μm
LL15	0 - 10	

4. Maximum rail length

Table 3 Length limitation of rails

Series	Size		Unit: mm				
	Material		15				
LL	Stainless steel		40	60	75	90	120

5. Reference number

Reference numbers shall be set to individual NSK linear guide when its specifications are finalized, and it is indicated on its specification drawing.

Please specify the reference number, except design serial number, to identify the product when ordering, requiring estimates, or inquiring about specifications from NSK.

LL 15 0060 PL K 1 -** PN 0						
Series name	LL	15	0060	PL	K 1	** PN 0
Size						
Rail length (mm)						
Ball slide shape code (See page A243.)						
Material / surface treatment code: K						
K: Stainless steel						
						Preload code: 0
						0: Z0
						Accuracy code: PN
						PN: Normal grade is only available.
						Design serial number
						Added to the reference number.
						Number of ball slides per rail

6. Dimensions

LL 15 0060 PL K 1 - PN 0**

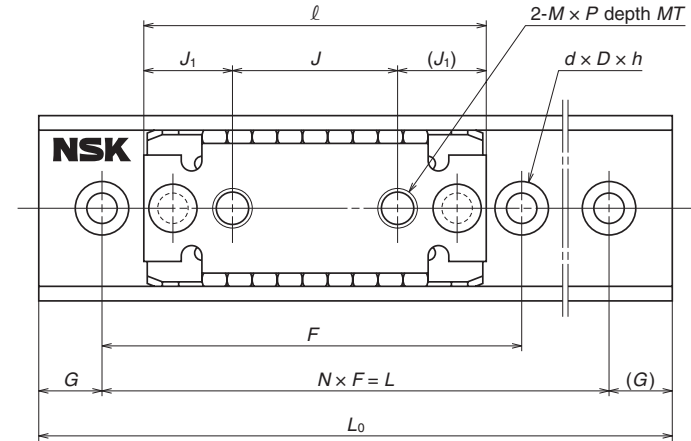
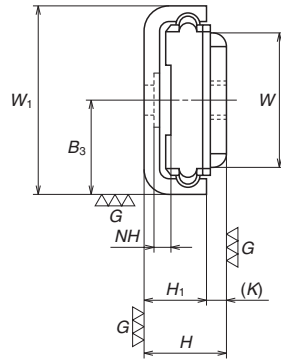
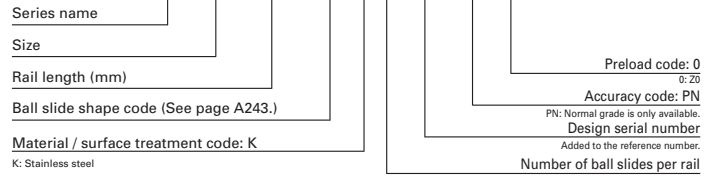

Model No.	Assembly		Ball slide							Height	Pitch	N
	Height	Width	Length	Mounting hole			J ₁	K				
				J	M × pitch	MT						
LL15	6.5	15	10.6	27	13	M3×0.5	1.2	7	1.5	5	30	1
											40	1
											30	2
											40	2
											50	2

- Notes:
- 1) The LL Series does not have a ball retainer. Be aware that the balls fall out when the ball slide is withdrawn from the rail.
 - 2) Seals are not available. Please provide the dust-prevention measures on the equipment.
 - 3) Do not use an installation screw on the ball slide which exceeds the dimension MT (maximum screw-in depth) in the dimension table.
 - 4) To fix the rail, use M2 × 0.4 cross recessed machine screw for precision instrument.
(JCIS10-70 No.0 pan head machine screw No.1)
(JCIS: Japanese Camera Industrial Standard)

Unit: mm

Rail		Basic load rating								Ball dia.	Weight	
Mounting bolt hole	Length	⁵⁾ Dynamic		Static	Static moment			D _w	Ball slide	Rail		
		[50km]	[100km]		C ₀	M _{R0}	M _{P0}				M _{V0}	
d × D × h	L ₀	C ₅₀ (N)	C ₁₀₀ (N)	(N)	(N·m)	(N·m)	(N·m)		(g)	(g)		
2.4×5×0.4	40	880	700	785	7	3	3	2	6	9		
	60									11		
	75									13		
	90									16		
	120									21		

- 5) C₅₀: the basic dynamic load rating for 50 km rated fatigue life
C₁₀₀: the basic dynamic load rating for 100 km rated fatigue life

1. RA Series**A249****2. LA Series****A271**

A-5-3 Machine Tools

A-5-3.1 RA Series



1. Features

(1) Super-high load capacity

By installing rollers that are the largest possible diameter and length within the existing standard cross-section dimension in a rational layout based on our advanced analysis technology, we have realized the world's highest load capacity,* far superior to conventional roller guides. Super-long life is achieved and impact load can be sufficiently handled.

* As of September 1, 2003; NSK's research and comparison on the existing products of the same sizes.

(2) Super-high rigidity

Using NSK's advanced analysis technology, we pursued a complete, optimal design, down to the detailed shape of roller slides and rails, thereby realizing super-high rigidity superior to that of competitor's roller guides.

(3) Super-high motion accuracy

NSK has developed its own unique method of simulating rolling element passage vibration and method of designing optimal roller slide specifications for damping roller passage vibration. These developments have dramatically enhanced roller slide motion accuracy for the RA series.

(4) Smooth motion

Installation of a retaining piece between rollers restrains the roller skew peculiar to roller slides, thereby achieving smooth motion.

(5) Low friction

Using rollers for rolling elements helps minimize dynamic friction.

(6) Random matching

Random-matching of rails and roller slides are available. (RA25 to RA65)

(7) Specification with highly dustproof V1 seal

Specification with newly developed, highly dustproof V1 seal which is the end seal with enhanced abrasion resistance is also available. (RA35 – 55)

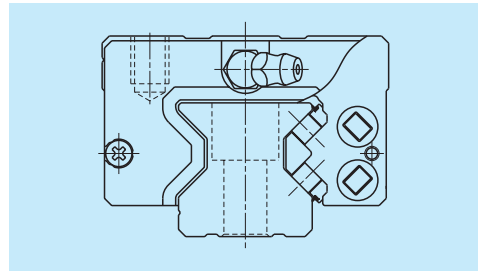

Fig. 1 RA Series

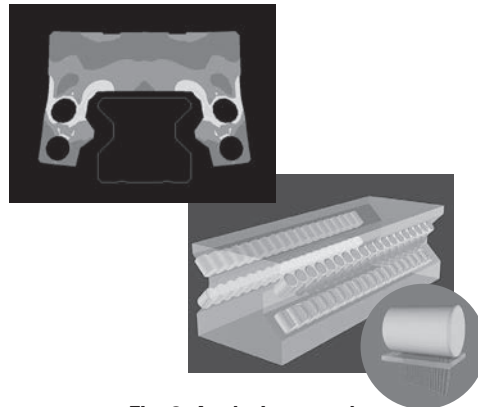

Fig. 2 Analysis example



Fig. 3 Random-matching type

2. Roller slide shape

Roller slide model	Shape/installation method	Type (Upper row, Rating: Lower row, Roller slide length)	
		High-load type	Super-high-load type
		Standard	Long
AN BN		AN 	BN
AL BL		AL 	BL
EM GM		EM 	GM

3. Accuracy and preload

(1) Running parallelism of roller slide

Table 1

Unit: μm

Rail length (mm)	Ultra precision P3	Super precision P4	High precision P5 _{PH}	Precision grade P6
	Preloaded assembly	Preloaded assembly	Preloaded assembly Random-matching type	Preloaded assembly
– 50	2	2	2	4.5
50 – 80	2	2	3	5
80 – 125	2	2	3.5	5.5
125 – 200	2	2	4	6
200 – 250	2	2.5	5	7
250 – 315	2	2.5	5	8
315 – 400	2	3	6	9
400 – 500	2	3	6	10
500 – 630	2	3.5	7	12
630 – 800	2	4	8	14
800 – 1 000	2.5	4.5	9	16
1 000 – 1 250	3	5	10	17
1 250 – 1 600	4	6	11	19
1 600 – 2 000	4.5	7	13	21
2 000 – 2 500	5	8	15	22
2 500 – 3 150	6	9.5	17	25
3 150 – 3 500	9	16	23	30

(2) Accuracy standard

The preloaded assembly has four accuracy grades; Ultra precision P3, Super precision P4, High precision P5, and Precision P6 grades, while the random-matching type has High precision PH grade only.

• **Tolerance of preloaded assembly**

Table 2 Unit: μm

Characteristics	Accuracy grade			
	Ultra precision P3	Super precision P4	High precision P5	Precision grade P6
Mounting height H	± 8	± 10	± 20	± 40
Variation of H (All roller slides on a set of rails)	3	5	7	15
Mounting width W_2 or W_3	± 10	± 15	± 25	± 50
Variation of W_2 or W_3 (All roller slides on reference rail)	3	7	10	20
Running parallelism of surface C to surface A Running parallelism of surface D to surface B	Shown in Table 1 and Fig. 4			

• **Tolerance of random-matching type**

Table 3 Unit: μm

Characteristics	Accuracy grade	
	High precision PH	
Mounting height H	± 20	
Variation of mounting height H	15① 25②	
Mounting width W_2 or W_3	± 25	
Variation of mounting width W_2 or W_3	20	
Running parallelism of surface C to surface A Running parallelism of surface D to surface B	See Table 1 and Fig. 4	

Note: ① Variation on the same rail ② Variation on multiple rails

(3) Combination of accuracy and preload

Table 4

	Accuracy grade					
	Ultra precision	Super precision	High precision	Precision grade	High precision	
Without NSK K1 lubrication unit	P3	P4	P5	P6	PH	
With NSK K1 lubrication unit	K3	K4	K5	K6	KH	
Preload	Slight preload Z1	○	○	○	○	—
	Medium preload Z3	○	○	○	○	—
	Random-matching type with slight preload ZZ	—	—	—	—	○
	Random-matching type with medium preload ZH	—	—	—	—	○

(4) Assembled accuracy

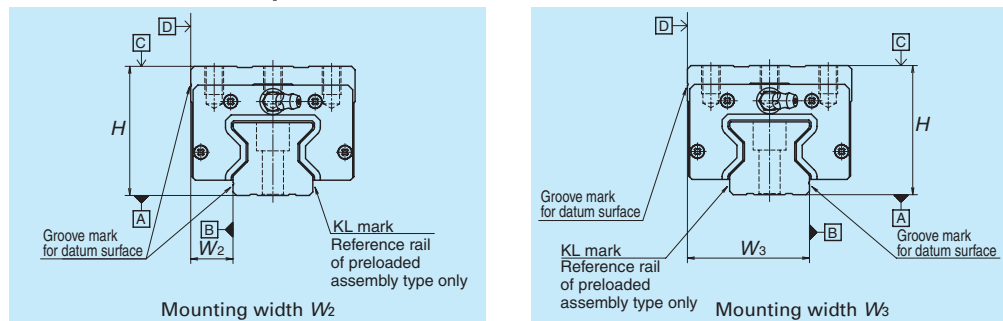

Fig. 4

(5) Preload and rigidity

Four types of preload are available: Medium preload Z3 and Slight preload Z1 for preloaded assembly, and Medium preload ZH and slight preload ZZ for Random-matching type.

• **Preload of preloaded assembly**

Table 5

Model No.	Preload (N)	
	Slight preload (Z1)	Medium preload (Z3)
High-load type	RA15 AN, AL, EM	— 1 030
	RA20 AN, EM	— 1 920
	RA25 AN, AL, EM	880 2 920
	RA30 AN, AL, EM	1 170 3 890
	RA35 AN, AL, EM	1 600 5 330
	RA45 AN, AL, EM	2 780 9 280
Super-high-load type	RA55 AN, AL, EM	3 800 12 900
	RA65 AN, EM	6 500 21 000
	RA15 BN, BL, GM	— 1 300
	RA20 BN, GM	— 2 400
	RA25 BN, BL, GM	1 060 3 540
	RA30 BN, BL, GM	1 430 4 760
RA35 BN, BL, GM	2 020 6 740	
RA45 BN, BL, GM	3 500 11 600	
RA55 BN, BL, GM	5 000 16 800	
RA65 BN, GM	8 500 28 800	

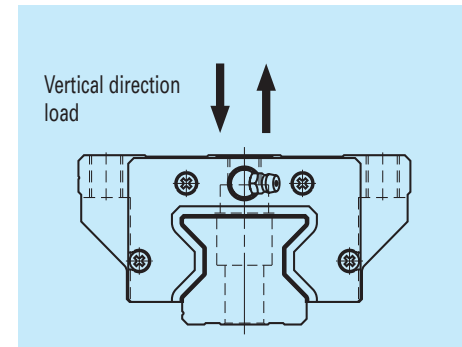

Fig. 5 Direction of load

• Rigidity of medium preload

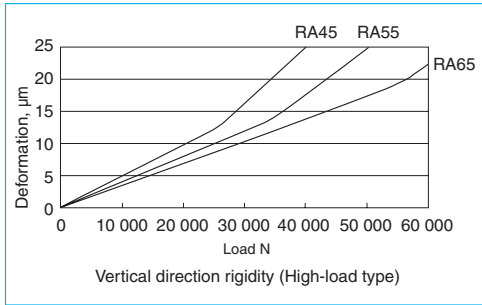
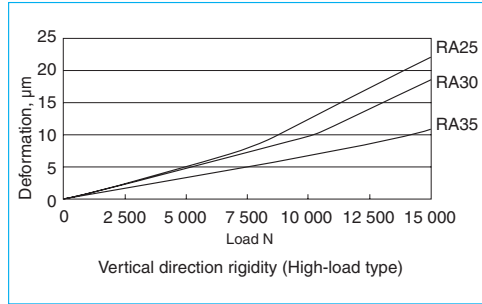
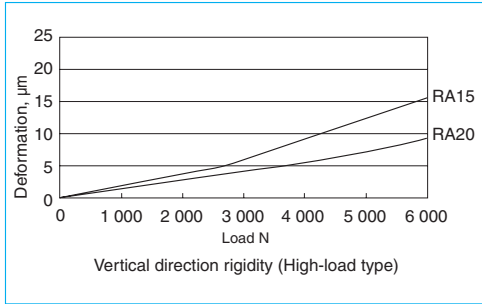

Fig. 6 Vertical direction theoretical rigidity line: High-load type (Roller slide shape: AN, AL, EM)

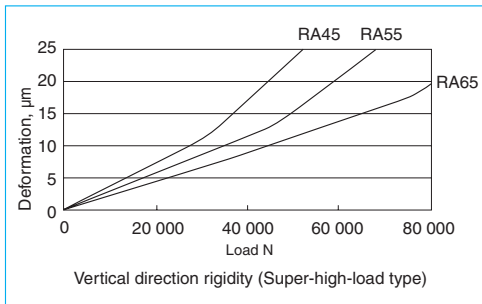
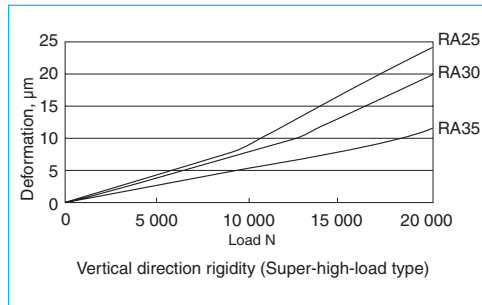
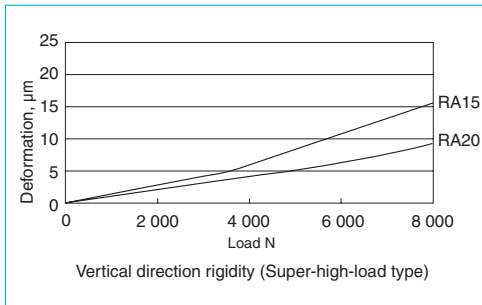

Fig. 7 Vertical direction theoretical rigidity line: Super-high-load type (Roller slide shape: BN, BL, GM)

4. Maximum rail length

Table 5 shows the limitations of rail length (maximum length). However, the limitations vary by accuracy grades.

Table 6 Length limitation of rails Unit: mm

Series	Size	15	20	25	30	35	45	55	65
RA		2 000	3 000	3 900	3 900	3 900	3 650	3 600	3 600

Note: Rails can be butted if user requirement exceeds the rail length shown in the table. Please consult NSK.

5. Installation

(1) Permissible values of mounting error

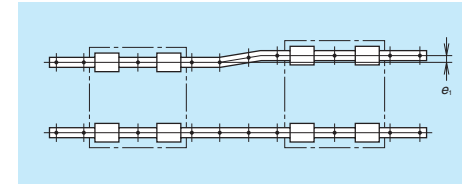

Fig. 8

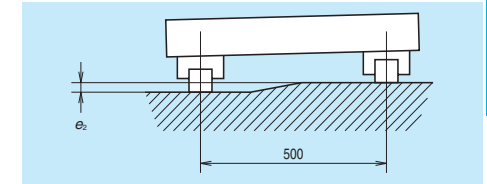

Fig. 9

Table 7 Unit: μm

Value	Preload	Model No.							
		RA15	RA20	RA25	RA30	RA35	RA45	RA55	RA65
Permissible values of parallelism in two rails e_1	Z1, ZZ	—	—	14	18	21	27	31	49
	Z3, ZH	5	7	9	11	13	17	19	30
Permissible values of parallelism (height) in two rails e_2	Z1, ZZ	290 μm / 500 mm							
	Z3, ZH	150 μm / 500 mm							

(2) Shoulder height of the mounting surface and corner radius

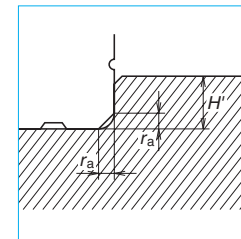

Fig. 10 Shoulder for the rail datum surface

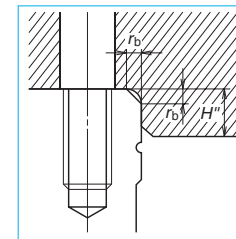

Fig. 11 Shoulder for the roller slide datum surface

Table 8 Unit: mm

Model No.	Corner radius (maximum)		Shoulder height	
	r_a	r_b	H'	H''
RA15	0.5	0.5	3	4
RA20	0.5	0.5	4	5
RA25	0.5	1	4	5
RA30	1	1	5	6
RA35	1	1	5	6
RA45	1.5	1	6	8
RA55	1.5	1.5	7	10
RA65	1.5	1.5	11	11

6. Lubrication components

Refer to pages A38 and D13 for the lubrication of linear guides.

(1) Types of lubrication accessories

Fig. 14 and Table 11 show grease fittings and tube fittings.

(2) Mounting position of lubrication accessories

- The standard position of grease fittings and tube fittings is the end face of roller slide. We can mount them on a side of end cap for an option. (Fig. 12) Please consult NSK for installation of grease or tube fittings to the roller slide body or the side of end cap.
- A lubrication hole can also be provided on the top of the end cap. Fig.13, Table 9 and Table 10 show the mounting position. A spacer is required for AN and BN shape roller slides. The spacers are available from NSK.
- When using a piping unit with thread of M6 × 1, you require a connector to connect it to a grease fitting mounting hole with M6 × 0.75. The connectors are available from NSK.

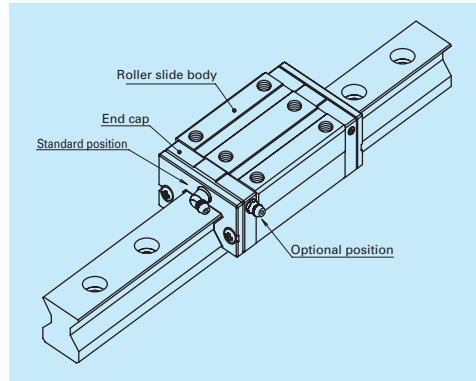

Fig. 12 Mounting position of lubrication accessories

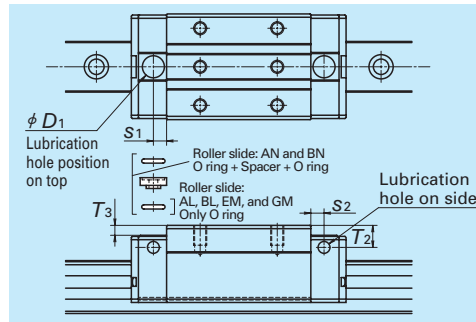

Fig.13 Top and side lubrication hole positions

Table 9 Top and side lubrication hole positions

Unit: mm

Model No.	Roller slide model	Grease fitting size	s_2	T_2	O ring (JIS)	Spacer	D_1	s_1	T_3
RA15	AN, BN	$\phi 3$	4	7	P5	Necessary	8.2	4.4	4.2
RA20		$\phi 3$	4	4	P6	—	9.2	5.4	0.2
RA25		M6×0.75	6	10	P7	Necessary	10	6	4.5
RA30		M6×0.75	5	10	P7+P5	Necessary	10.4	6	3.5
RA35		M6×0.75	5.5	15	P7+P5	Necessary	10.4	7	7.4
RA45		Rc 1/8	7.2	20	P7+P5	Necessary	10.4	7.2	10.4
RA55		Rc 1/8	7.2	21	P7+P5	Necessary	10.4	7.2	10.4
RA65		Rc 1/8	7.2	19	P7	—	10.4	7.2	0.4

Table 10 Top and side lubrication hole positions

Unit: mm

Model No.	Roller slide model	Grease fitting size	s_2	T_2	O ring (JIS)	D_1	s_1	T_3
RA15	AL, BL, EM, GM	$\phi 3$	4	3	P5	8.2	4.4	0.2
RA20	EM, GM	$\phi 3$	4	4	P6	9.2	5.4	0.2
RA25	AL, BL, EM, GM	M6×0.75	6	6	P7	10	6	0.5
RA30		M6×0.75	5	7	P7	10.4	6	0.5
RA35		M6×0.75	5.5	8	P7	10.4	7	0.4
RA45		Rc 1/8	7.2	10	P7	10.4	7.2	0.4
RA55		Rc 1/8	7.2	11	P7	10.4	7.2	0.4
RA65	EM, GM	Rc 1/8	7.2	19	P7	10.4	7.2	0.4

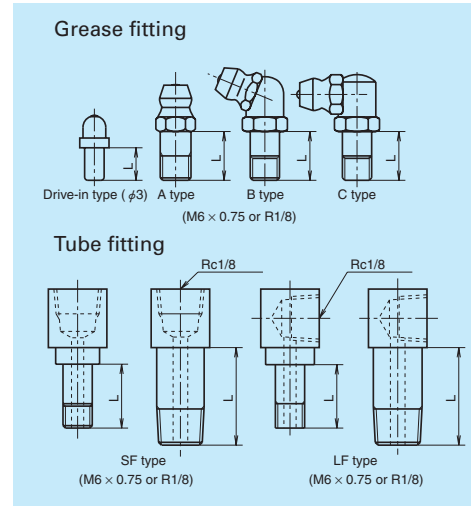

Fig. 14 Grease fitting and tube fitting

7. Dust-proof components

(1) Standard specification

The RA series is equipped with end, inner* and bottom seals to prevent foreign matter from entering the inside of the roller slide. Under normal applications, the RA series can be used without modification.

For severe usage conditions, optional rail covers** are available. Contact NSK for information on how to mount the cover.

*) Inner seals for the models of RA15 and RA20 are available as options.

***) The rail cover is available to the models of RA25 to RA65.

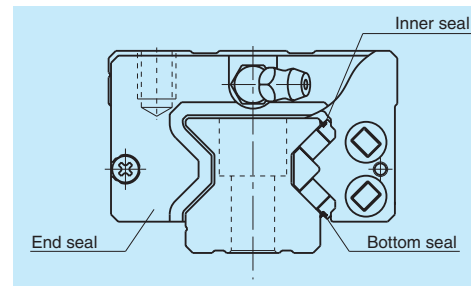

Fig. 15

Table 12 Seal friction per roller slide (maximum value)

Unit: N

Series	Size	15	20	25	30	35	45	55	65
RA		4	5.5	5	5	6	8	8	14



Fig. 16 Rail cover

Table 11 Unit: mm

Model No.	Dust-proof specification	Dimension L		
		Grease fitting /Drive-in type	Tube fitting	
		SF type	LF type	
RA15	Standard	5	—	—
	With NSK K1	10	—	—
	Double seal	8	—	—
RA20	Standard	5	—	—
	With NSK K1	10	—	—
	Double seal	8	—	—
RA25	Standard	5	5	5
	With NSK K1	12	12	12
	Double seal	10	9	9
RA30	Standard	5	6	6
	With NSK K1	14	14	15
	Double seal	12	12	11
RA35	Standard	5	6	6
	With NSK K1	14	14	15
	Double seal	12	12	11
RA45	Standard	8	13.5	17
	With NSK K1	18	20	21.5
	Double seal	14	16	17
RA55	Standard	8	13.5	17
	With NSK K1	18	20	21.5
	Double seal	14	16	17
RA65	Standard	8	13.5	17
	With NSK K1	20	20	20
	Double seal	14	18	17

(2) NSK K1™ lubrication unit

Table 12 shows the dimension of linear guides equipped with the NSK K1 lubrication unit.

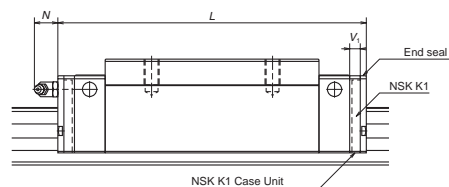

Table 13

Unit: mm

Model No.	Roller slide length	Roller slide model	Standard roller slide length	With two NSK K1	Thickness of NSK K1 V_1	Protruding area of the grease fitting N
RA15	Standard	AN, AL, EM	70	79	4.5	(3)
	Long	BN, BL, GM	85.4	94.4		
RA20	Standard	AN, EM	86.5	95.5	4.5	(3)
	Long	BN, GM	106.3	115.3		
RA25	Standard	AN, AL, EM	97.5	107.5	5	(11)
	Long	BN, BL, GM	115.5	125.5		
RA30	Standard	AN, AL, EM	110.8	122.8	6	(11)
	Long	BN, BL, GM	135.4	147.4		
RA35	Standard	AN, AL, EM	123.8	136.8	6.5	(11)
	Long	BN, BL, GM	152	165		
RA45	Standard	AN, AL, EM	154	168	7	(14)
	Long	BN, BL, GM	190	204		
RA55	Standard	AN, AL, EM	184	198	7	(14)
	Long	BN, BL, GM	234	248		
RA65	Standard	AN, EM	228.4	243.4	7.5	(14)
	Long	BN, GM	302.5	317.5		

Note: Roller slide length equipped with NSK K1 = (Standard roller slide length) + (Thickness of NSK K1 Case Unit × Number of NSK K1 Case Unit)

(3) Double seal and protector

For RA Series, double seal and protector can be installed only before shipping from the factory.

Table 14 shows the increased thickness when end seal and protector are installed.

Table 14

Unit: mm

Model No.	Thickness of end seal V_3	Thickness of protector V_4
RA15	3	2.7
RA20	3	3.3
RA25	3.2	3.3
RA30	3.4	3.6
RA35	3.4	3.6
RA45	4	4.2
RA55	4	4.2
RA65	5	5.5

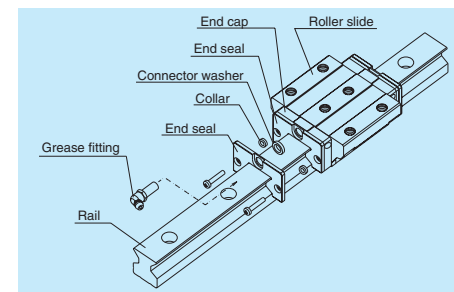

Fig. 17 Double seal

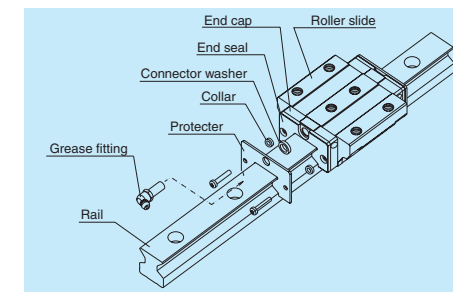

Fig. 18 Protector

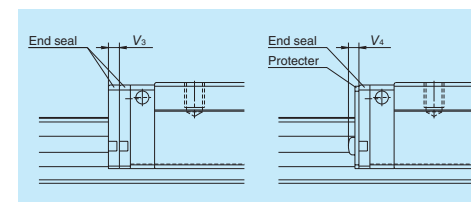

Fig. 19

(4) Rail cover

When the rail cover is used, use the cover bracket to secure the rail cover. Fig.20 shows the dimensions for the cover bracket. The required room at the end of the rail is:

- Inside: 10.5 mm or less
 - Outside: 4 mm or less (Common to the models of RA25 to RA65)
- Please confirm the interference with your machine at the stroke end.
- Machine stroke
 - Room for the end of the rail

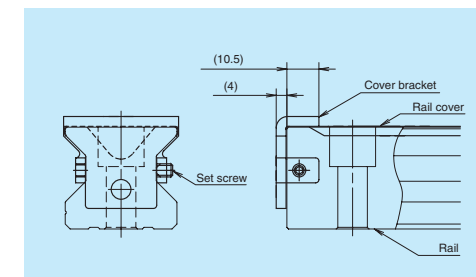

Fig. 20 End configuration of rail equipped with the rail cover

The height of the rail with the rail cover is shown in Table 15.

Table 15 Height of rails equipped with rail cover

Unit: mm

Model No.	Standard height H_1	Cover installation
RA25	24	24.2
RA30	28	28.2
RA35	31	31.25
RA45	38	38.3
RA55	43.5	43.8
RA65	55	55.3

(5) Cap to plug the rail mounting bolt hole

Table 16 Caps to plug rail bolt hole

Model No.	Bolt to secure rail	Cap reference No.	Quantity /case
RA15	M4	LG-CAP/M4	20
RA20	M5	LG-CAP/M5	20
RA25	M6	LG-CAP/M6	20
RA30, RA35	M8	LG-CAP/M8	20
RA45	M12	LG-CAP/M12	20
RA55	M14	LG-CAP/M14	20
RA65	M16	LG-CAP/M16	20

(6) Specification with highly dustproof V1 seal

RA25, RA30, RA35, RA45, and RA55 also have the specification with newly developed, highly dustproof V1 seal which is the end seal with enhanced abrasion resistance.

Highly dustproof V1 Seal made of new materials and in a new shape for better abrasion resistance prevents foreign matter getting into the roller slide for a long period.

Inner seal and bottom seal are equipped as standard. In addition, outstanding lubrication effects by NSK K1 further improves the durability. The bolt hole caps whose shape is partly changed eliminate building up of foreign matter in and around the rail mounting holes and prevent foreign matter from entering into the roller slide. Otherwise, the rail cover with higher dustproofness can be selected.

See A258 for the details of the rail cover.

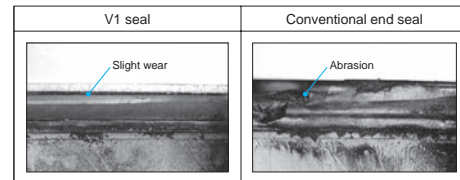
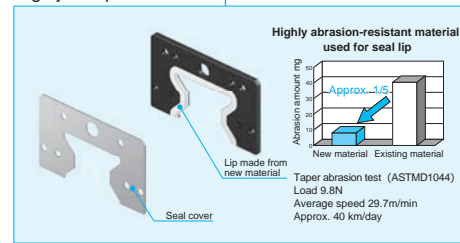
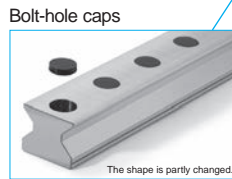
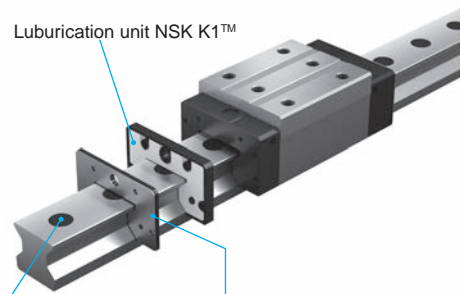

●Durability test under extreme conditions - no lubrication

With this new material, even if lubrication is poor, damage such as roughening of surfaces will not occur.

Test sample: RA35

Operation without lubrication on the seal

Feed speed: 500 mm/sec

Table 17 shows the dimension for roller slide with V1 seal.

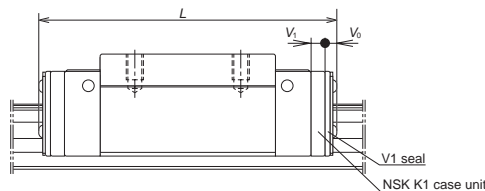

Since the sealing property (resistance to foreign matter) is affected by usage or the lubrication environment, please conduct an evaluation test for your particular application.

Table 17

Unit: mm

Model No.	Roller slide length	Roller slide type	Standard roller slide length L	Roller slide length equipped with V1 seal L	Roller slide length equipped with V1 seal and NSK K1 L	Thickness of V1 seal V ₆	Thickness of K1 case unit V ₁
RA25	Standard	AN, AL, EM	97.5	101.3	111.3	5.1	5
	Long	BN, BL, GM	115.5	119.3	129.3		
RA30	Standard	AN, AL, EM	110.8	114.8	126.8	5.4	6
	Long	BN, BL, GM	135.4	139.4	151.4		
RA35	Standard	AN, AL, EM	123.8	127.8	140.8	5.4	6.5
	Long	BN, BL, GM	152	156	169		
RA45	Standard	AN, AL, EM	154	159.2	173.2	6.6	7
	Long	BN, BL, GM	190	195.2	209.2		
RA55	Standard	AN, AL, EM	184	189.2	203.2	6.6	7
	Long	BN, BL, GM	234	239.2	253.2		

●Design Precautions

Because the product is used under severe operating conditions that require highly dustproof VI seals, please inform NSK about your service conditions using the technical data sheet on page A152.

(7) Bellows

Installation of bellows

*** Fixing to the roller slide**

Remove two machine screws which secure the end seal. (For RA15, hold the end cap by hand. Otherwise, the end cap is detached from the slide, and the roller inside may spill over.)

Insert a spacer to the securing hole of the end seal, fasten the mounting plate at the end of the bellows using a slightly longer machine screw. (For RA15, insert a flat spacer between the end seal and the mounting plate at the end of the bellows.)

*** Fixing to the rail**

For fixing to the rail, make tap holes to the rail end surface. Fix the bellows mounting plate with machine screws to the rail end surface through these tap holes. NSK processes the tap holes to the rail end surface when ordered with a linear guide.

Calculating length of bellows

The formulas for calculating length of bellows for the end are as follows.

$$\text{Stroke } St = L_{\max} - L_{\min}$$

Length when stretched to the maximum length

$$L_{\max} = f_b \cdot P \times \text{Number of folds}$$

Length when contracted to the minimum length

$$L_{\min} = 2.5 \times \text{Number of folds} + 3$$

Values of f_b and P are shown in the bellows dimension table. Based on these above formulas, calculate the number of folds as follows.

$$\text{Number of folds} = \frac{St - 3}{f_b \cdot P - 2.5}$$

Round up the calculated value so that the number of folds will be $n + 0.5$ (n : the natural number).

For the length of a middle bellows, please ask NSK.

Bellow reference number

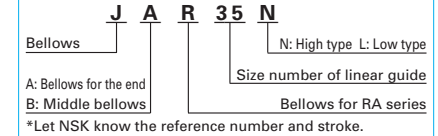

*Let NSK know the reference number and stroke.

Dimension table of bellows
RA series

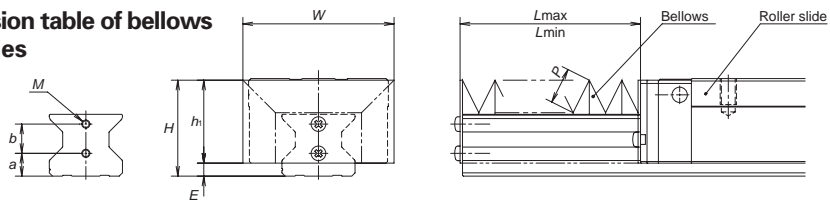

Fig. 21 Dimensions of bellows

Table 18 Dimensions of bellows

Unit: mm(excluding f_b)

Model No.	H	h_1	E	W	P	f_b	a	b	Tap (M) × depth
JAR15L	23.5	19.5	4	33	7	1.2	7	6.3	M3 × 5
JAR15N	27	23		39	10	1.3			
JAR20N	29	24	5	43	8	1.3	8.5	9	M3 × 5
JAR25L	35	30	5	55	10	1.3	8.5	12	M3 × 5
JAR25N	39	34		61	14	1.4			
JAR30L	41	34.5	6.5	60	12	1.3	11	12.5	M4 × 6
JAR30N	44	37.5		66	15	1.4			
JAR35L	47	40.5	6.5	72	15	1.4	11	15	M4 × 6
JAR35N	54	47.5		82	20	1.5			
JAR45L	59	51	8	93	20	1.5	14	18	M5 × 8
JAR45N	69	61		113	30	1.5			
JAR55L	69	60	9	101	20	1.5	15	22	M5 × 8
JAR55N	79	70		121	30	1.5			
JAR65N	89	76	13	131	30	1.5	21	26	M6 × 10

Note: f_b is a dimensionless number

8. Dynamic friction

- Dynamic friction indications per roller slide are shown in Table 19.
- These values are assumed under actual condition with standard specification (two end seals, inner seal and bottom seal equipped) packed with standard grease (NSK Grease AS2)
- Dynamic friction varies with grease.

Table 19 Dynamic friction

Unit: N

Model No.	High-load type	Super-high-load type
RA15	21	24
RA20	22	28
RA25	27	34
RA30	33	42
RA35	42	53
RA45	56	69
RA55	80	95
RA65	120	138

Note: Values in Table 19 are indications. Please refer to them.

Roller Guide RA Series

9. Reference number

Reference numbers shall be set to individual NSK linear guide when its specifications are finalized, and it is indicated on its specification drawing.
Please specify the reference number, except design serial number, to identify the product when ordering, requiring estimates, or inquiring about specifications from NSK.

(1) Reference number for preloaded assembly

RA 35 1000 ANC 2 - P6 3**

Series name	Preload code (See page A251.) 1: Z1, 3: Z3
Size	Accuracy code (See Table 21.)
Rail length (mm)	Design serial number Added to the reference number.
Roller slide shape code (See page A250.)	Number of roller slides per rail
Material/surface treatment code (See Table 20.) C: Special high carbon steel (NSK standard)	

(2) Reference number for random-matching type

Roller slide

RAA 35 AN PHH -F

Random-matching roller slide series code RAA: RA Series random-matching roller slide	Option code No code: No surface treatment -F: Fluoride low temperature chrome plating -C: No surface treatment + Rail cover -CF: Fluoride low temperature chrome plating + Rail cover
Size	Preload code: Z Z: Slight preload, H: Medium preload
Roller slide shape code (See page A250.)	Accuracy code PH, KH: High-precision grade random-matching type (See Table 21.)

Rail

R1A35 1000 L CN - PH Z**

Random-matching rail series code R1A: RA Series random-matching rail	Preload code: Z Z: Common for slight and medium preload (See page A251.)
Size	Accuracy code PH: High-precision grade random-matching type
Rail length (mm)	Design serial number Added to the reference number.
Rail shape code: L L: Standard	*Butting rail specification N: Non-butting, L: Butting specification
Material/surface treatment code (See Table 20.)	

*Please consult with NSK for butting rail specification.

The reference number coding for the assembly of random-matching type is the same as that of the preloaded assembly. However, the applicable preload codes are "slight preload Z" and "medium preload H". (See page A251.)

Table 20 Material/surface treatment code

Code	Description
C	Special high carbon steel (NSK standard)
D	Special high carbon steel with surface treatment
P	Special high carbon steel with V1 seal
R	Special high carbon steel with surface treatment and V1 seal
Z	Other, special

Note : P and R are not available for random-matching slides and rails.

Table 21 Accuracy code

Accuracy	Standard (Without NSK K1)	With NSK K1
Ultra precision grade	P3	K3
Super precision grade	P4	K4
High precision grade	P5	K5
Precision grade	P6	K6
High precision grade (Random-matching type)	PH	KH

Note: Refer to pages A38 for NSK K1 lubrication unit.

10. Dimensions

RA-AN (High-load type / Standard)

RA-BN (Super-high-load type / Long)

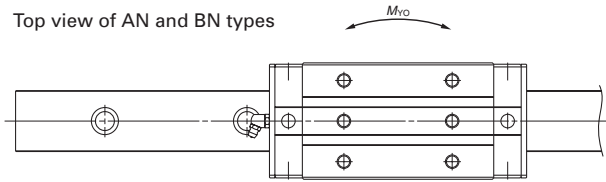
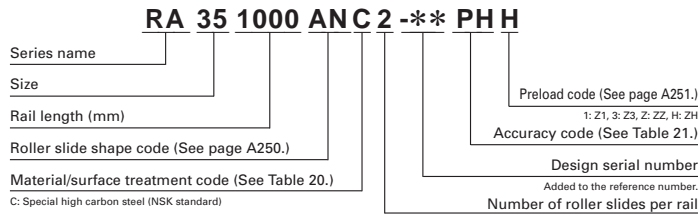

Front view of AN and BN types

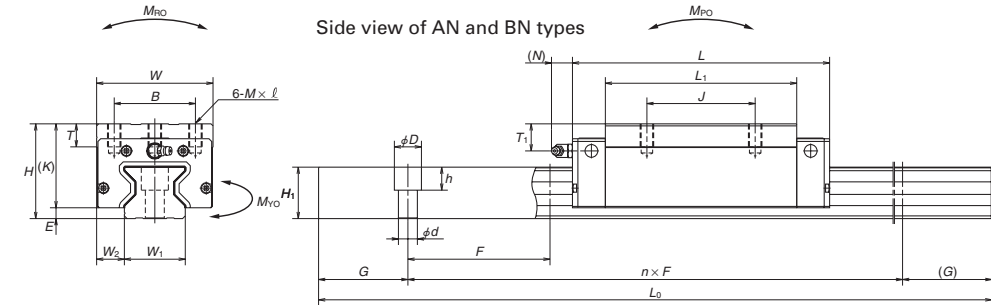

Model No.	Assembly			Roller slide										Width	Height			
	Height	E	W ₂	W	Length	Mounting hole			L ₁	K	T	Grease fitting				W ₁	H ₁	
						B	J	M × pitch × ℓ				Hole size	T ₁					N
RA15AN RA15BN	28	4	9.5	34	70 85.4	26	26	M4×0.7×6	44.8 60.2	24	8	φ3	8	3	15	16.3		
RA20AN RA20BN	30	5	12	44	86.5 106.3	32	36	M5×0.8×6	57.5 77.3	25	12	φ3	4	3	20	20.8		
RA25AN RA25BN	40	5	12.5	48	97.5 115.5	35	35	M6×1×9	65.5 83.5	35	12	M6×0.75	10	11	23	24		
RA30AN RA30BN	45	6.5	16	60	110.8 135.4	40	40	M8×1.25×11	74 98.6	38.5	14	M6×0.75	10	11	28	28		
RA35AN RA35BN	55	6.5	18	70	123.8 152	50	50	M8×1.25×12	83.2 111.4	48.5	15	M6×0.75	15	11	34	31		
RA45AN RA45BN	70	8	20.5	86	154 190	60	60	M10×1.5×17	105.4 141.4	62	17	Rc1/8	20	14	45	38		
RA55AN RA55BN	80	9	23.5	100	184 234	75	75	M12×1.75×18	128 178	71	18	Rc1/8	21	14	53	43.5		
RA65AN RA65BN	90	13	31.5	126	228.4 302.5	76	70	M16×2×20	155.4 229.5	77	22	Rc1/8	19	14	63	55		

Notes: 1) Select either one of two F dimensions, the standard or the parenthesized semi-standard dimension, for the pitch of rail fixing bolt holes. If not specified, the standard dimension of F is applied.

Reference number for roller slide of random-matching type

Roller slide

RAA 35 AN PH H -F

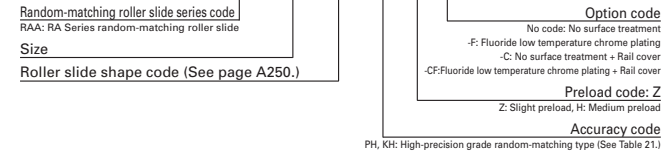

AN and BN types

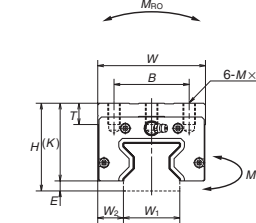

AN type

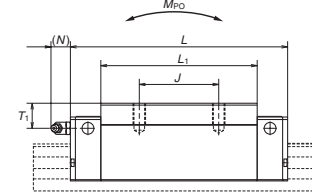

BN type

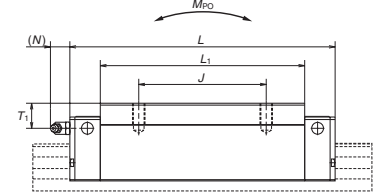

Reference number for rail of random-matching type

Rail

R1A35 1000 L C N - PH Z**

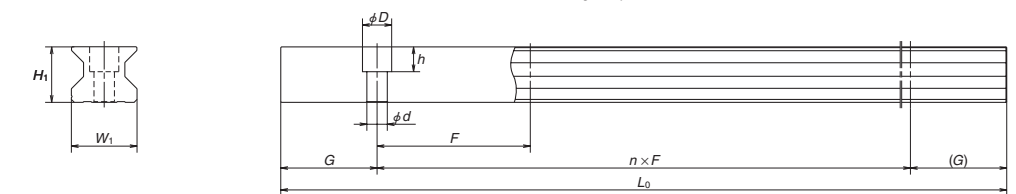
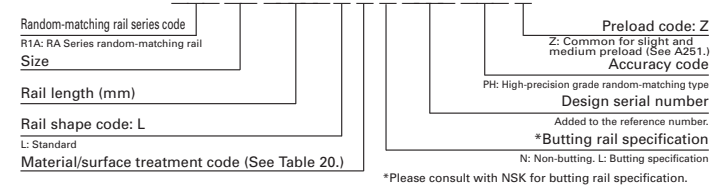

Unit: mm

Rail		Basic load rating								Weight			
Pitch	Mounting bolt hole	G	Maximum length	Dynamic		Static	Static moment (N-m)				Roller slide	Rail	
				[50km]	[100km]		C ₀	M _{PO}		M _{YO}			
				C ₅₀ (N)	C ₁₀₀ (N)	(N)		One slide	Two slides	One slide			Two slides
60 (30)	4.5×7.5×5.3	20	2 000	12 600	10 300	27 500	260	210	1 320	210	1 320	0.21	1.6
60 (30)	6×9.5×8.5	20	3 000	16 000	13 000	37 000	350	375	2 130	375	2 130	0.30	
60 (30)	7×11×9	20	3 900	23 600	19 200	52 500	665	505	3 100	505	3 100	0.38	2.6
60 (30)	9×14×12	20	3 900	29 500	24 000	70 000	890	900	5 000	900	5 000	0.50	
30 (60)	7×11×9	20	3 900	36 000	29 200	72 700	970	760	4 850	760	4 850	0.60	3.4
40 (80)	9×14×12	20	3 900	43 500	35 400	92 900	1 240	1 240	7 200	1 240	7 200	0.91	
40 (80)	9×14×12	20	3 900	47 800	38 900	93 500	1 670	1 140	7 100	1 140	7 100	1.0	4.9
40 (80)	9×14×12	20	3 900	58 500	47 600	121 000	2 170	1 950	11 500	1 950	11 500	1.3	
40 (80)	9×14×12	20	3 900	65 500	53 300	129 000	2 810	1 800	11 000	1 800	11 000	1.6	6.8
40 (80)	9×14×12	20	3 900	82 900	67 400	175 000	3 810	3 250	17 800	3 250	17 800	2.1	
52.5 (105)	14×20×17	22.5	3 650	114 000	92 800	229 000	6 180	4 080	24 000	4 080	24 000	3.0	10.9
52.5 (105)	14×20×17	22.5	3 650	143 000	116 000	305 000	8 240	7 150	39 000	7 150	39 000	4.1	
60 (120)	16×23×20	30	3 600	159 000	129 000	330 000	10 200	7 060	41 000	7 060	41 000	4.9	14.6
60 (120)	16×23×20	30	3 600	207 000	168 000	462 000	14 300	13 600	72 000	13 600	72 000	6.7	
75 (150)	18×26×22	35	3 600	259 000	210 000	504 000	19 200	12 700	78 500	12 700	78 500	9.3	22.0
75 (150)	18×26×22	35	3 600	355 000	288 000	756 000	28 700	28 600	153 000	28 600	153 000	12.2	

2) The random-matching type is available for the models of RA25 to RA65.

3) The basic load rating comply with the ISO standard. (ISO 14728-1, 14728-2)

C₅₀: the basic dynamic load rating for 50 km rated fatigue life
 C₁₀₀: the basic dynamic load rating for 100 km rated fatigue life

RA-AL (High-load type / Standard)
RA-BL (Super-high-load type / Long)

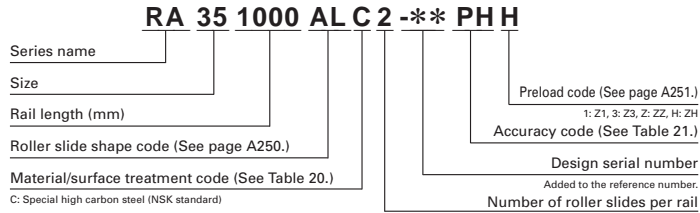

Top view of AL and BL types

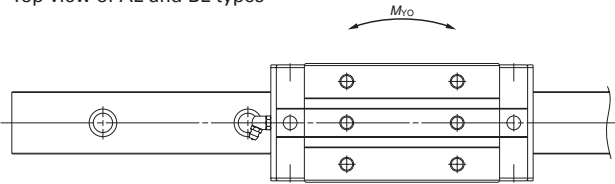

Front view of AL and BL types

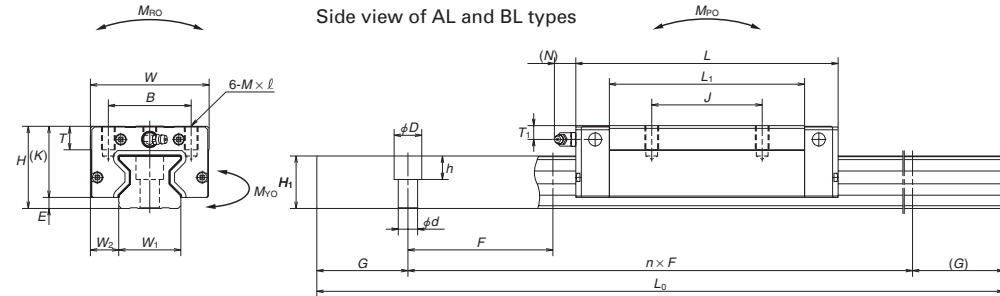

Side view of AL and BL types

Model No.	Assembly			Roller slide										Width	Height			
	Height	E	W ₂	Width	Length	Mounting hole			L ₁	K	T	Grease fitting				W ₁	H ₁	
						B	J	M × pitch × ℓ				Hole size	T ₁					N
RA15AL RA15BL	24	4	9.5	34	70 85.4	26	26	M4×0.7×5.5	44.8 60.2	20	8	φ3	4	3	15	16.3		
RA25AL RA25BL	36	5	12.5	48	97.5 115.5	35	35	M6×1×8	65.5 83.5	31	12	M6×0.75	6	11	23	24		
RA30AL RA30BL	42	6.5	16	60	110.8 135.4	40	40	M8×1.25×11	74 98.6	35.5	14	M6×0.75	7	11	28	28		
RA35AL RA35BL	48	6.5	18	70	123.8 152	50	50	M8×1.25×12	83.2 111.4	41.5	15	M6×0.75	8	11	34	31		
RA45AL RA45BL	60	8	20.5	86	154 190	60	60	M10×1.5×16	105.4 141.4	52	17	Rc1/8	10	14	45	38		
RA55AL RA55BL	70	9	23.5	100	184 234	75	75	M12×1.75×18	128 178	61	18	Rc1/8	11	14	53	43.5		

Notes: 1) Select either one of two F dimensions, the standard or the parenthesized semi-standard dimension, for the pitch of rail fixing bolt holes. If not specified, the standard dimension of F is applied.

Reference number for roller slide of random-matching type

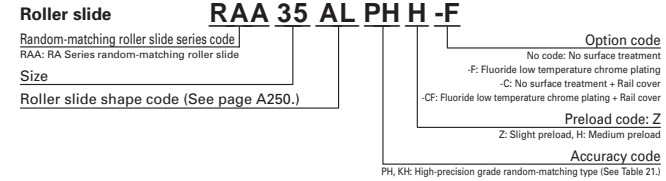

AL and BL types

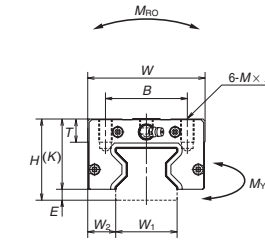

AL type

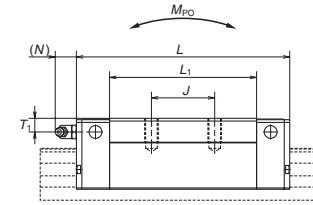

BL type

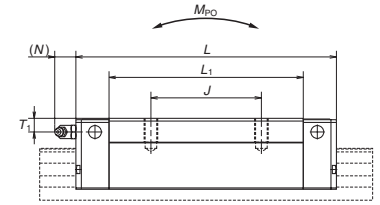

Reference number for rail of random-matching type

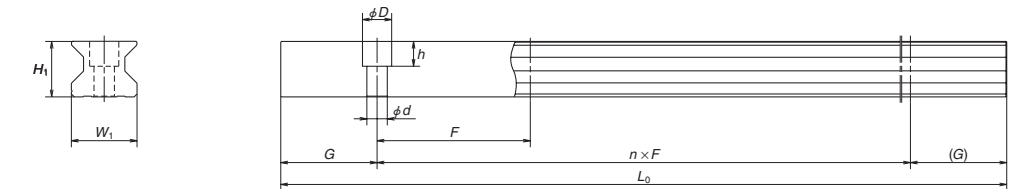
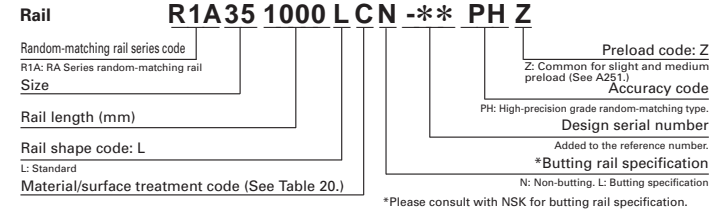

Unit: mm

Rail		Basic load rating								Weight			
Pitch	Mounting bolt hole	G	Maximum length	Dynamic		Static	Static moment (N·m)				Roller slide	Rail	
				[50km]	[100km]		C ₀	M _{PO}		M _{YO}			
								C ₅₀ (N)	C ₁₀₀ (N)	(N)			One slide
60 (30)	4.5×7.5×5.3	20	2 000	12 600	10 300	27 500	260	210	1 320	210	1 320	0.17	1.6
30 (60)	7×11×9	20	3 900	16 000	13 000	37 000	350	375	2 130	375	2 130	0.25	
40 (80)	9×14×12	20	3 900	36 000	29 200	72 700	970	760	4 850	760	4 850	0.45	3.4
40 (80)	9×14×12	20	3 900	43 500	35 400	92 900	1 240	1 240	7 200	1 240	7 200	0.80	
40 (80)	9×14×12	20	3 900	47 800	38 900	93 500	1 670	1 140	7 100	1 140	7 100	0.85	4.9
40 (80)	9×14×12	20	3 900	58 500	47 600	121 000	2 170	1 950	11 500	1 950	11 500	1.1	
52.5 (105)	14×20×17	22.5	3 650	65 500	53 300	129 000	2 810	1 800	11 000	1 800	11 000	1.2	6.8
60 (120)	16×23×20	30	3 600	82 900	67 400	175 000	3 810	3 250	17 800	3 250	17 800	1.7	
60 (120)	16×23×20	30	3 600	114 000	92 800	229 000	6 180	4 080	24 000	4 080	24 000	2.5	10.9
60 (120)	16×23×20	30	3 600	143 000	116 000	305 000	8 240	7 150	39 000	7 150	39 000	3.4	
60 (120)	16×23×20	30	3 600	159 000	129 000	330 000	10 200	7 060	41 000	7 060	41 000	4.1	14.6
60 (120)	16×23×20	30	3 600	207 000	168 000	462 000	14 300	13 600	72 000	13 600	72 000	5.7	

2) The random-matching type is available for the models of RA25 to RA55.
 3) The basic load rating comply with the ISO standard. (ISO 14728-1, 14728-2)
 C₅₀: the basic dynamic load rating for 50 km rated fatigue life
 C₁₀₀: the basic dynamic load rating for 100 km rated fatigue life

RA-EM (High-load type / Standard)
RA-GM (Super-high-load type / Long)

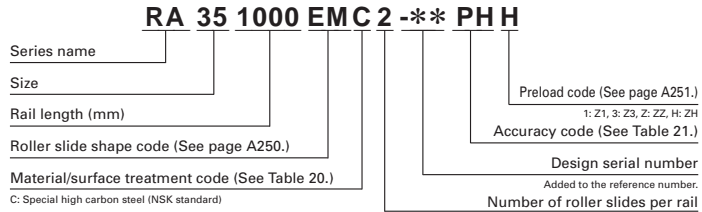

Front view of EM and GM types

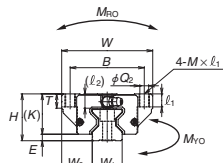

RA15, 20, 25, 30

Top view of EM and GM types

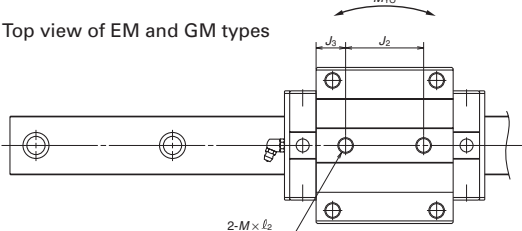

RA15, 20, 25 and 30: Bolts cannot be installed from the underside.

Side view of EM and GM types

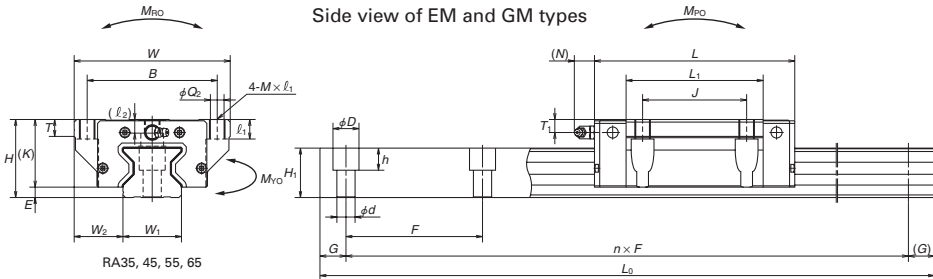

RA35, 45, 55, 65

Model No.	Assembly			Roller slide											Grease fitting	
	Height H	E	W ₂	Width W	Length L	Mounting hole					L ₁	K	T	Hole size	T ₁	N
						B	J	J ₂	M × pitch × ℓ _(ℓ₂)	Q ₂						
RA15EM	24	4	16	47	70	38	30	26	M5×0.8×8.5 (6.5)	4.4	44.8	20	8	φ 3	4	3
RA15GM					85.4						60.2					
RA20EM	30	5	21.5	63	86.5	53	40	35	M6×1×9.5 (8)	5.3	57.5	25	10	φ 3	4	3
RA20GM					106.3						77.3					
RA25EM	36	5	23.5	70	97.5	57	45	40	M8×1.25×10 (11)	6.8	65.5	31	11	M6×0.75	6	11
RA25GM					115.5						83.5					
RA30EM	42	6.5	31	90	110.8	72	52	44	M10×1.5×12 (12.5)	8.6	74	35.5	11	M6×0.75	7	11
RA30GM					135.4						98.6					
RA35EM	48	6.5	33	100	123.8	82	62	52	M10×1.5×13 (7)	8.6	83.2	41.5	12	M6×0.75	8	11
RA35GM					152						111.4					
RA45EM	60	8	37.5	120	154	100	80	60	M12×1.75×15 (10.5)	10.5	105.4	52	13	Rc1/8	10	14
RA45GM					190						141.4					
RA55EM	70	9	43.5	140	184	116	95	70	M14×2×18 (13)	12.5	128	61	15	Rc1/8	11	14
RA55GM					234						178					
RA65EM	90	13	53.5	170	228.4	142	110	82	M16×2×24 (18.5)	14.6	155.4	77	22	Rc1/8	19	14
RA65GM					302.5						229.5					

Notes: 1) Select either one of two F dimensions, the standard or the parenthesized semi-standard dimension, for the pitch of rail fixing bolt holes. If not specified, the standard dimension of F is applied.

Reference number for roller slide of random-matching type

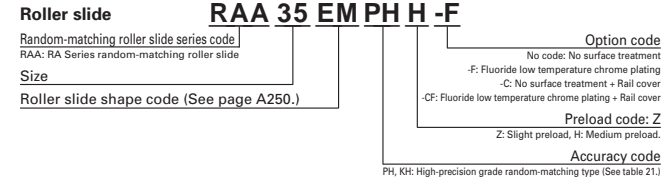

EM and GM types

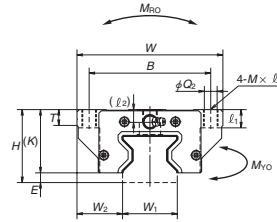

EM type

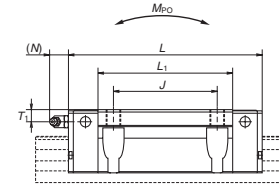

GM type

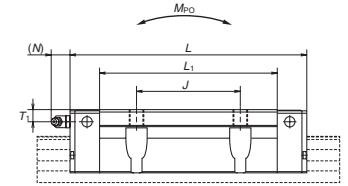

Reference number for rail of random-matching type

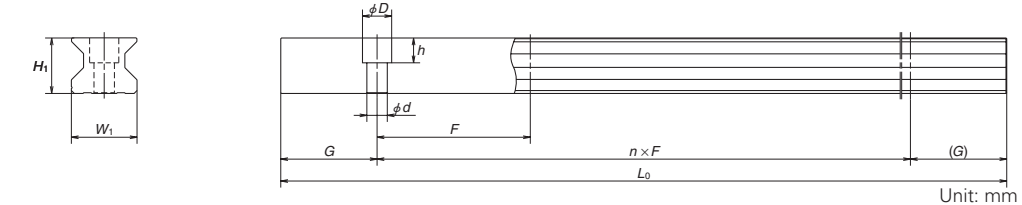
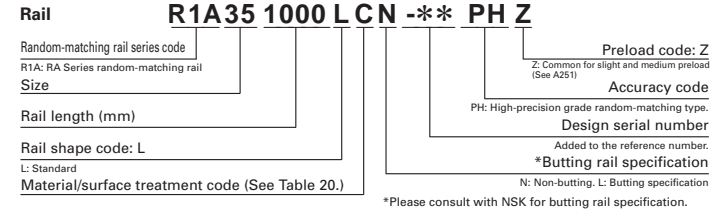

Unit: mm

Rail			Basic load rating											Weight	
Width W ₁	Height H ₁	Pitch F	Mounting bolt hole d × D × h	G	Maximum length L _{0max}	³⁾ Dynamic		Static		Static moment (N-m)				Roller slide (kg)	Rail (kg/m)
						C ₅₀ (N)	C ₁₀₀ (N)	C ₀ (N)	M _{RO}	M _{PO}		M _{YO}			
15	16.3	60 (30)	4.5×7.5×5.3	20	2 000	12 600	10 300	27 500	260	210	1 320	210	1 320	0.21	1.6
20	20.8	60 (30)	6×9.5×8.5	20	3 000	23 600	19 200	52 500	665	505	3 100	505	3 100	0.45	2.6
23	24	30 (60)	7×11×9	20	3 900	36 000	29 200	72 700	970	760	4 850	760	4 850	0.80	3.4
28	28	40 (80)	9×14×12	20	3 900	43 500	35 400	92 900	1 240	920	7 200	1 240	7 200	1.1	4.9
34	31	40 (80)	9×14×12	20	3 900	65 500	53 300	129 000	2 810	1 800	11 000	1 800	11 000	1.7	6.8
45	38	52.5 (105)	14×20×17	22.5	3 650	114 000	92 800	229 000	6 180	4 080	24 000	4 080	24 000	3.2	10.9
53	43.5	60 (120)	16×23×20	30	3 600	143 000	116 000	305 000	8 240	7 150	39 000	7 150	39 000	4.3	14.6
63	55	75 (150)	18×26×22	35	3 600	259 000	210 000	504 000	19 200	12 700	78 500	12 700	78 500	12.2	22.0

2) The random-matching type is available for the models of RA25 to RA65.
 3) The basic load rating comply with the ISO standard. (ISO 14728-1, 14728-2)
 C₅₀: the basic dynamic load rating for 50 km rated fatigue life
 C₁₀₀: the basic dynamic load rating for 100 km rated fatigue life

A-5-3.2 LA Series

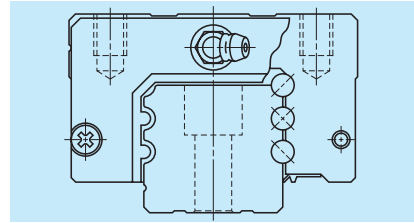
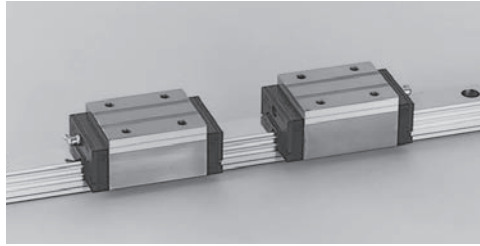

Fig. 1 LA Series

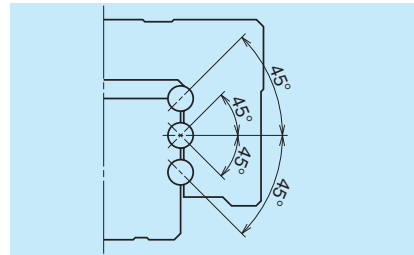

Fig. 2 Super rigidity design

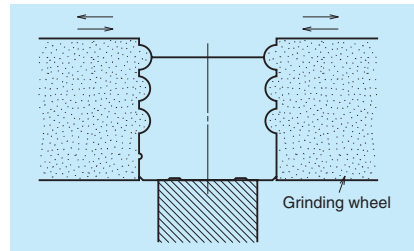

Fig. 3 Rail grinding

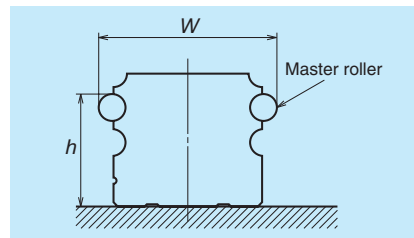

Fig. 4 Measuring groove accuracy

1. Features

(1) High rigidity and high load carrying capacity

A set of three ball grooves is made on both sides of ball slide and a rail. This contributes to the increased rigidity and load carrying capacity. The top and bottom groove are formed in the circular arc with a closer radius of ball, which ensures great rigidity and load carrying capacity. With the Gothic arch center groove, rigidity and load carrying capacity are further increased.

(2) Moderate friction

A well-balanced combination of 2-point contacts at the top and bottom grooves and 4 points contact at the center groove provides moderate friction while ensuring rigidity by appropriate preload.

(3) Four-way equal load distribution

The contact angle of balls is set at 45 degrees in all grooves, thereby dispersing the load equally to four rows irrespective of load direction. This realizes equal rigidity and load carrying capacity in vertical and lateral directions and provides well-balanced design.

(4) Strong against shock load

Load from any direction, vertical and lateral, is received by four ball rows at all times. The number of the ball rows which receive the load is larger than in other linear guides, making this series stronger against shock load.

(5) High accuracy

As showing in Fig. 4, fixing the measuring rollers is easy thanks to the Gothic arch groove of the central ball groove. This benefits an accurate and measuring of ball groove for a highly precise and stable manufacturing.

(6) The dust protection design

The rail's cross section is designed as simple as possible, thereby improving the sealing efficiency combined with the enhanced sealing function. In addition, optional inner seals are available.

2. Ball slide shape

Ball slide Model	Shape/installation method	Type (Upper row, Rating: Lower row, Ball slide length)	
		High-load type	Super-high-load type
		Standard	Long
AN BN		AN 	BN
AL BL		AL 	BL
EL GL		EL 	GL
FL HL		FL 	HL

3. Accuracy and preload

(1) Running parallelism of ball slide

Table 1

Unit: μm

Rail length (mm)	Preloaded assembly (not random matching)			
	Ultra precision P3	Super precision P4	High precision P5	Precision grade P6
over 50	2	2	2	4.5
50 - 80	2	2	3	5
80 - 125	2	2	3.5	5.5
125 - 200	2	2	4	6
200 - 250	2	2.5	5	7
250 - 315	2	2.5	5	8
315 - 400	2	3	6	9
400 - 500	2	3	6	10
500 - 630	2	3.5	7	12
630 - 800	2	4.5	8	14
800 - 1 000	2.5	5	9	16
1 000 - 1 250	3	6	10	17
1 250 - 1 600	4	7	11	19
1 600 - 2 000	4.5	8	13	21
2 000 - 2 500	5	10	15	22
2 500 - 3 150	6	11	17	25
3 150 - 4 000	9	16	23	30

(2) Accuracy standard

The LA Series has four accuracy grades: Ultra precision P3, Super precision P4, High precision P5, and Precision grade P6.

Table 2 Unit: μm

Accuracy grade	Ultra precision P3	Super precision P4	High precision P5	Precision grade P6
Mounting height H Variation of H (All ball slides on a set of rails)	± 10 3	± 10 5	± 20 7	± 40 15
Mounting width W_2 or W_3 Variation of W_2 or W_3 (All ball slides on reference rail)	± 15 3	± 15 7	± 25 10	± 50 20
Running parallelism of surface C to surface A Running parallelism of surface D to surface B	Shown in Table 1 and Fig. 5			

(3) Assembled accuracy

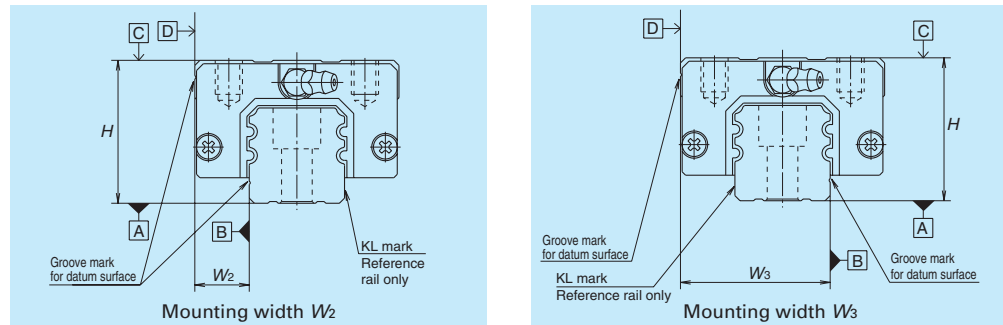

Fig. 5

4. Preload and rigidity

Table 3 shows preload and rigidity of LA Series.

The LA Series has two types of preload specification: Medium preload Z3 and Heavy preload Z4.

Table 3

	Model No.	Preload (N)		Rigidity (N/ μm)	
		Medium preload Z3	Heavy preload Z4	Medium preload Z3	Heavy preload Z4
High-load type	LA25 AL, AN, EL, FL	1 670	2 110	475	550
	LA30 AL, AN, EL, FL	2 450	3 150	705	835
	LA35 AL, AN, EL, FL	3 450	4 300	825	970
	LA45 AL, AN, EL, FL	5 050	6 350	1 100	1 240
	LA55 AL, AN, EL, FL	8 100	10 200	1 400	1 540
Super-high-load type	LA65 AN, EL, FL	13 800	18 800	1 730	2 030
	LA25 BL, BN, GL, HL	2 260	2 840	700	820
	LA30 BL, BN, GL, HL	3 250	4 050	1 000	1 180
	LA35 BL, BN, GL, HL	4 450	5 650	1 200	1 400
	LA45 BL, BN, GL, HL	6 150	7 750	1 450	1 640
	LA55 BL, BN, GL, HL	9 550	12 100	1 840	2 020
	LA65 BN, GL, HL	18 000	24 400	2 450	2 840

4. Maximum rail length

Table 4 shows the limitations of rail length. However, the limitations vary by accuracy grades.

Table 4 Length limitations of rails Unit: mm

Series	Size	25	30	35	45	55	65
LA		3 960	4 000	4 000	3 990	3 960	3 900

Note: Rails can be butted if user requirement exceeds the rail length shown in the table. Please consult NSK.

5. Installation

(1) Permissible values of mounting error

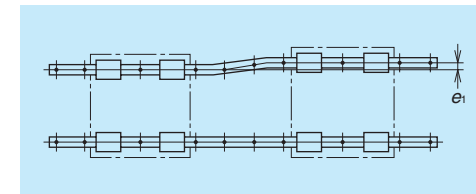

Fig. 6

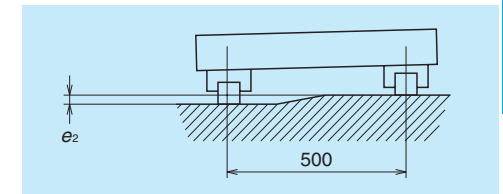

Fig. 7

Table 5

Value	Preload	Model No.					
		LA25	LA30	LA35	LA45	LA55	LA65
Permissible values of parallelism in two rails e_1	Z3	15	17	20	25	30	40
	Z4	13	15	17	20	25	30
Permissible values of parallelism (height) in two rails e_2	Z3, Z4	185 $\mu\text{m}/500 \text{ mm}$					

(2) Shoulder height of the mounting surface and corner radius r

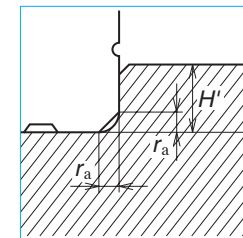

Fig. 8 Shoulder for the rail datum surface

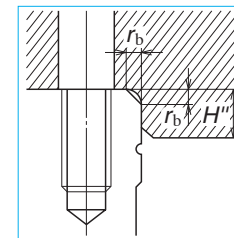

Fig. 9 Shoulder for the ball slide datum surface

Table 6

Model No.	Corner radius (maximum)		Shoulder height	
	r_a	r_b	H'	H''
LA25	0.5	0.5	5	5
LA30	0.5	0.5	6	6
LA35	0.5	0.5	6	6
LA45	0.7	0.7	8	8
LA55	0.7	0.7	10	10
LA65	1	1	11	11

6. Lubrication components

Refer to pages A38 and D13 for the lubrication of linear guides.

(1) Types of lubrication accessories

Fig. 10 and Table 7 show grease fittings and tube fittings.

(2) Mounting position of lubrication accessories

- The standard position of grease fittings is the end face of ball slide. We mount them on a side of end cap for an option. (Fig. 11).
- Please consult NSK for installation of grease or tube fittings to the ball slide body or side of end cap.
- When using a piping unit with thread of M6 × 1, you require a connector to connect to a grease fitting mounting hole with M6 × 0.75. The connector is available from NSK.

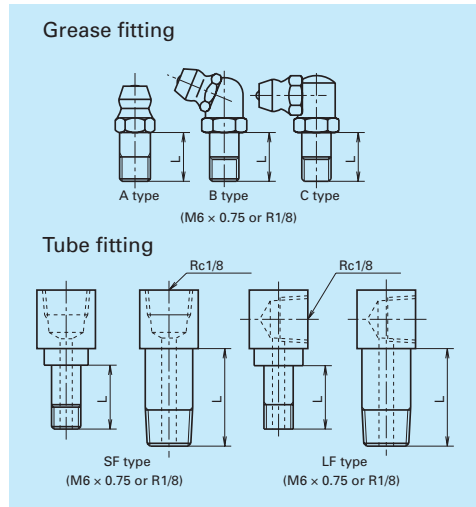

Fig. 10 Grease fitting and tube fitting

Table 7 Unit: mm

Model No.	Dust-proof specification	Dimension L		
		Grease fitting	Tube fitting	
			SF type	LF type
LA25	Standard	5	5	5
	With NSK K1	14	12	12
	Double seal	10	9	9
LA30	Protector	10	9	9
	Standard	5	6	6
	With NSK K1	14	12	13
LA35	Double seal	12	10	11
	Protector	12	11	11
	Standard	5	6	6
LA45	With NSK K1	14	12	13
	Double seal	12	10	11
	Protector	12	11	11
LA55	Standard	8	13.5	17
	With NSK K1	18	22	21.5
	Double seal	14	18	17
LA65	Protector	14	16	17
	Standard	8	13.5	17
	With NSK K1	22	24	25.5
		16	20	19
		16	16	17

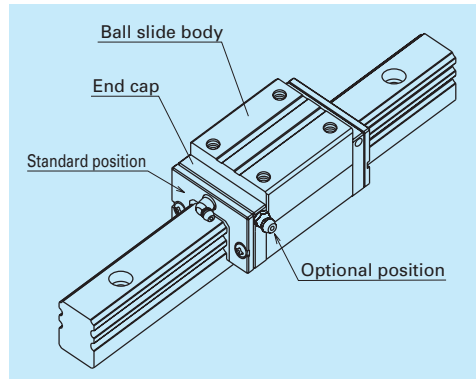

Fig. 11 Mounting position of lubrication accessories

7. Dust-proof components

(1) Standard Specification

The LA Series can be readily used as they have a dust protection means for normal conditions. As the standard equipment, the ball slides have an end seal on both ends, and bottom seals at the bottom.

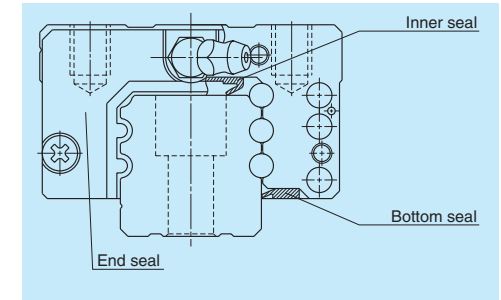

Fig. 12

Table 8 Seal friction per ball slide (maximum value) Unit: N

Series	Size	25	30	35	45	55	65
LA		11	11	12	17	17	23

(2) NSK K1™ lubrication unit

Table 9 shows the dimension of linear guides equipped with the NSK K1 lubrication unit.

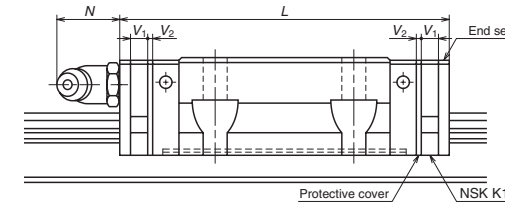

Table 9 Unit: mm

Model No.	Ball slide length	Ball slide model	Standard ball slide length	Ball slide length installed with two NSK K1 L	Per NSK K1 thickness V ₁	Protective cover thickness V ₂	Protruding area of the grease fitting N
LA25	Standard	AL, AN, EL, FL	79.8	91.8	5.0	1.0	(14)
	Long	BL, BN, GL, HL	107.8	119.8			
LA30	Standard	AL, AN, EL, FL	100.2	113.2	5.5	1.0	(14)
	Long	BL, BN, GL, HL	126.2	139.2			
LA35	Standard	AL, AN, EL, FL	110.6	123.6	5.5	1.0	(14)
	Long	BL, BN, GL, HL	144.6	157.6			
LA45	Standard	AL, AN, EL, FL	141.4	156.4	6.5	1.0	(15)
	Long	BL, BN, GL, HL	173.4	188.4			
LA55	Standard	AL, AN, EL, FL	165.4	180.4	6.5	1.0	(15)
	Long	BL, BN, GL, HL	203.4	218.4			
LA65	Standard	AN, EL, FL	196.2	214.2	8.0	1.0	(16)
	Long	BN, GL, HL	256.2	274.2			

Note: Ball slide length equipped with NSK K1 = (Standard ball slide length) + (Thickness of NSK K1, V₁ × Number of NSK K1) + (Thickness of the protective cover V₂ × 2)

(3) Double seal and protector

For the LA Series, a double seal and a protector can be installed only before shipping from the factory. Please consult with NSK when the double seal and the protectors are required.

Table 10 shows the increased thickness of V_3 and V_4 when end seals and protectors are installed (**Fig. 15**).

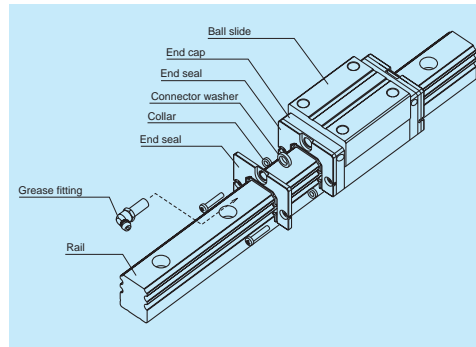

Fig. 13 Double seal

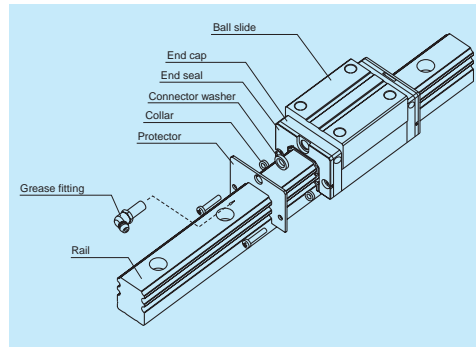

Fig. 14 Protector

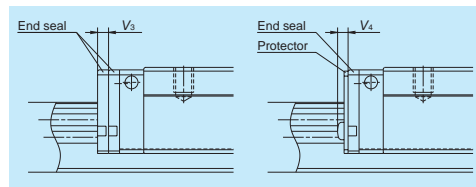

Fig. 15

Table 10

Unit: mm

Model No.	Thickness of end seal: V_3	Thickness of protector: V_4
LA25	3.2	3.6
LA30	4.4	4.2
LA35	4.4	4.2
LA45	5.5	4.9
LA55	5.5	4.9
LA65	6.5	5.5

(4) Cap to plug the rail mounting bolt hole

Table 11 Caps to plug rail bolt hole

Model No.	Bolt to secure rail	Cap reference No.	Quantity /case
LA25	M6	LG-CAP/M6	20
LA30, LA35	M8	LG-CAP/M8	20
LA45	M12	LG-CAP/M12	20
LA55	M14	LG-CAP/M14	20
LA65	M16	LG-CAP/M16	20

(5) Bellows

Make tap holes to the rail end face to fix the bellows mounting plate.

NSK processes tap holes to the rail end face when ordered with a linear guide.

Dimension tables of bellows LA Series

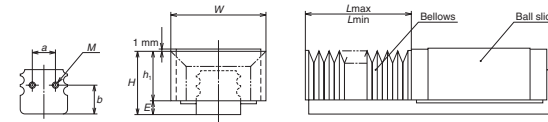

Fig. 16 Dimensions of bellows

Bellows reference number

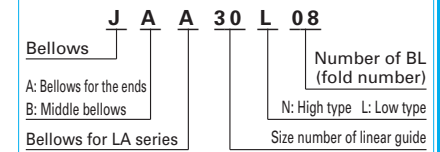

Table 12 Dimensions of bellows

Unit: mm

Model No.	H	h_1	E	W	P	a	b	Length of BL	Tap (M) × depth
JAA25L	35	29.5	5.5	55	12	12	13.8	17	M3 × 5
JAA25N	39	33.5	5.5	61	15	12	13.8	17	M3 × 5
JAA30L	41	33.5	7.5	60	12	14	17.5	17	M4 × 6
JAA30N	44	36.5	7.5	66	15	14	17.5	17	M4 × 6
JAA35L	47	39.5	7.5	72	15	15	18.8	17	M4 × 6
JAA35N	54	46.5	7.5	82	20	15	18.8	17	M4 × 6
JAA45L	59	49	10	93	20	25	22.5	17	M5 × 8
JAA45N	69	59	10	113	30	25	22.5	17	M5 × 8
JAA55L	69	57	12	101	20	35	27.1	17	M5 × 8
JAA55N	79	67	12	121	30	35	27.1	17	M5 × 8
JAA65N	89	75	14	131	30	40	33.3	17	M6 × 12

Table 13 Numbers of folds (BL) and length of bellows

Unit: mm

Type	Model No.	Length of BL	Number of folds (BL)									
			2	4	6	8	10	12	14	16	18	20
Low type	JAA25L	Stroke	134	268	402	536	670	804	938	1 072	1 206	1 340
		L_{max}	168	336	504	672	840	1 008	1 176	1 344	1 512	1 680
High type	JAA25N	Stroke	176	352	528	704	880	1 056	1 232	1 408	1 584	1 760
		L_{max}	210	420	630	840	1 050	1 260	1 470	1 680	1 890	2 100
Low type	JAA30L	Stroke	134	268	402	536	670	804	938	1 072	1 206	1 340
		L_{max}	168	336	504	672	840	1 008	1 176	1 344	1 512	1 680
High type	JAA30N	Stroke	176	352	528	704	880	1 056	1 232	1 408	1 584	1 760
		L_{max}	210	420	630	840	1 050	1 260	1 470	1 680	1 890	2 100
Low type	JAA35L	Stroke	176	352	528	704	880	1 056	1 232	1 408	1 584	1 760
		L_{max}	210	420	630	840	1 050	1 260	1 470	1 680	1 890	2 100
High type	JAA35N	Stroke	246	492	738	984	1 230	1 476	1 722	1 968	2 214	2 460
		L_{max}	280	560	840	1 120	1 400	1 680	1 960	2 240	2 520	2 800
Low type	JAA45L	Stroke	246	492	738	984	1 230	1 476	1 722	1 968	2 214	2 460
		L_{max}	280	560	840	1 120	1 400	1 680	1 960	2 240	2 520	2 800
High type	JAA45N	Stroke	386	772	1 158	1 544	1 930	2 316	2 702	3 088	3 474	3 860
		L_{max}	420	840	1 260	1 680	2 100	2 520	2 940	3 360	3 780	4 200
Low type	JAA55L	Stroke	246	492	738	984	1 230	1 476	1 722	1 968	2 214	2 460
		L_{max}	280	560	840	1 120	1 400	1 680	1 960	2 240	2 520	2 800
High type	JAA55N	Stroke	386	772	1 158	1 544	1 930	2 316	2 702	3 088	3 474	3 860
		L_{max}	420	840	1 260	1 680	2 100	2 520	2 940	3 360	3 780	4 200
Low/high type	JAA65N*	Stroke	386	772	1 158	1 544	1 930	2 316	2 702	3 088	3 474	3 860
		L_{max}	420	840	1 260	1 680	2 100	2 520	2 940	3 360	3 780	4 200

* Bellows for LA65 is for both low and high types.

Note : The values of an odd number BL quantity (3, 5, 7, ...) can be obtained by adding two values of the even number BL on the both sides, then by dividing the sum by 2.

8. Reference number

Reference numbers shall be set to individual NSK linear guide when its specifications are finalized, and it is indicated on its specification drawing.
Please specify the reference number, except design serial number, to identify the product when ordering, requiring estimates, or inquiring about specifications from NSK.

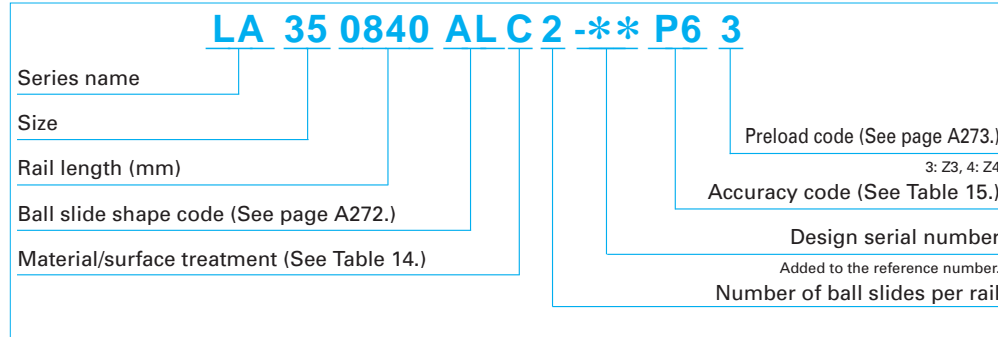

Table 14 Material/surface treatment code

Code	Description
C	Special high carbon steel (NSK standard)
D	Special high carbon steel with surface treatment
Z	Other, special

Table 15 Accuracy code

Accuracy	Standard (Without NSK K1)	With NSK K1
Ultra precision grade	P3	K3
Super precision grade	P4	K4
High precision grade	P5	K5
Precision grade	P6	K6

Note: Refer to pages A38 for NSK K1 lubrication unit.

9. Dimensions

LA-AL (High-load type / Standard)
LA-BL (Super-high-load type / Long)

LA 35 0840 AL C 2 - P6 3**

Series name	Preload code (See page A273.)
Size	3: Z3, 4: Z4
Rail length (mm)	Accuracy code (See Table 15.)
Ball slide shape code (See page A272.)	Design serial number
Material/surface treatment (See Table 14.)	Added to the reference number.
	Number of ball slides per rail

Front view of AL and BL types

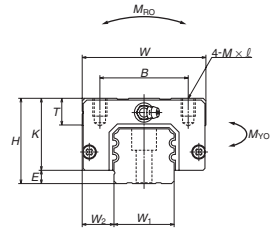

Side view of AL type

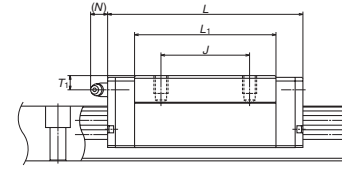

Side view of BL type

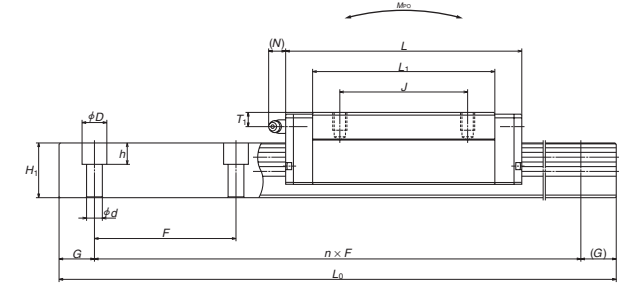

Unit: mm

Model No.	Assembly			Ball slide										Width	Height	
	Height	Width	Length	Mounting hole						Grease fitting						
				B	J	M x pitch x l	L1	K	T	Hole size	T1	N				
LA25AL	36	5.5	12.5	48	79.8	35	35	M6x1x7	58	30.5	8	M6x0.75	6	11	23	22
LA25BL					107.8	50			86							
LA30AL	42	7.5	16	60	100.2	40	40	M8x1.25x10	72	34.5	11	M6x0.75	6.5	11	28	28
LA30BL					126.2	60			98							
LA35AL	48	7.5	18	70	110.6	50	50	M8x1.25x10	80	40.5	15	M6x0.75	8	11	34	30.8
LA35BL					144.6	72			114							
LA45AL	60	10	20.5	86	141.4	60	60	M10x1.5x16	105	50	17	Rc1/8	10	13	45	36
LA45BL					173.4	80			137							
LA55AL	70	12	23.5	100	165.4	75	75	M12 x 1.75x16	126	58	18	Rc1/8	11	13	53	43.2
LA55BL					203.4	95			164							

Notes: 1) LA Series does not have a ball retainer. Be aware that balls fall out when the ball slide is withdrawn from the rail.

Rail				Basic load rating						Weight			
Pitch	Mounting bolt hole	G	Max. length	² Dynamic		Static	Static moment (N-m)				Ball slide	Rail	
				[50km]	[100km]		C ₀	M _{P0}		M _{Y0}			
				C ₅₀ (N)	C ₁₀₀ (N)	(N)		One slide	Two slides	One slide	Two slides	(kg)	(kg/m)
60	7x11x9	20	3 960	30 000	23 900	50 000	290	410	2 490	410	2 490	0.5	3.7
				40 500	32 500	77 000	445	935	5 000	935	5 000	0.8	
80	9x14x12	20	4 000	47 000	37 000	77 500	535	820	4 800	820	4 800	0.8	5.8
				58 000	46 000	105 000	725	1 470	8 050	1 470	8 050	1.2	
80	9x14x12	20	4 000	61 500	49 000	98 000	845	1 130	6 750	1 130	6 750	1.3	7.7
				80 500	64 000	143 000	1 240	2 330	12 500	2 330	12 500	1.6	
105	14x20x17	22.5	3 990	91 000	72 000	148 000	1 840	2 210	12 900	2 210	12 900	2.5	12.0
				111 000	88 000	197 000	2 460	3 850	20 600	3 850	20 600	3.2	
120	16x23x20	30	3 960	139 000	111 000	215 000	3 150	3 800	22 000	3 800	22 000	3.9	17.2
				172 000	137 000	292 000	4 250	6 800	36 000	6 800	36 000	5.1	

2) The basic load rating comply with the ISO standard. (ISO 14728-1, 14728-2)

C₅₀: the basic dynamic load rating for 50 km rated fatigue life
C₁₀₀: the basic dynamic load rating for 100 km rated fatigue life

LA-AN (High-load type / Standard)
LA-BN (Super-high-load type / Long)

LA 35 0840 ANC 2 - P6 3**

Series name	Preload code (See page A273.)
Size	3: Z3, 4: Z4
Rail length (mm)	Accuracy code (See Table 15.)
Ball slide shape code (See page A272.)	Design serial number
Material/surface treatment (See Table 14.)	Added to the reference number.
	Number of ball slides per rail

Front view of AN and BN types

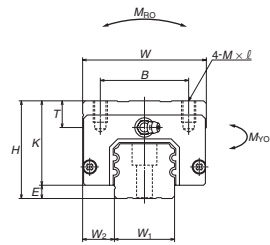

Side view of AN type

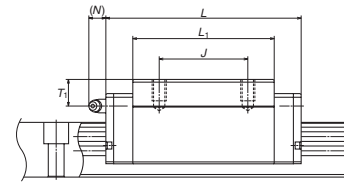

Side view of BN type

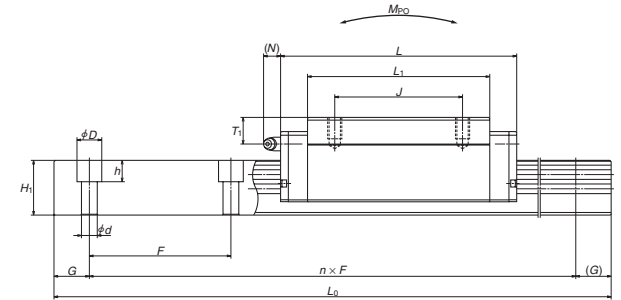

Unit: mm

Model No.	Assembly			Ball slide										Width	Height	
	Height	Width	Length	Mounting hole						Grease fitting						
				H	E	W_2	W	L	B	J	$M \times \text{pitch} \times l$	L_1	K			T
LA25AN	40	5.5	12.5	48	79.8	35	35	M6×1×10	58	34.5	12	M6×0.75	10	11	23	22
LA25BN					107.8	50			86							
LA30AN	45	7.5	16	60	100.2	40	40	M8×1.25×11	72	37.5	14	M6×0.75	9.5	11	28	28
LA30BN					126.2	60			98							
LA35AN	55	7.5	18	70	110.6	50	50	M8×1.25×12	80	47.5	15	M6×0.75	15	11	34	30.8
LA35BN					144.6	72			114							
LA45AN	70	10	20.5	86	141.4	60	60	M10×1.5×16	105	60	17	Rc1/8	20	13	45	36
LA45BN					173.4	80			137							
LA55AN	80	12	23.5	100	165.4	75	75	M12×1.75×18	126	68	18	Rc1/8	21	13	53	43.2
LA55BN					203.4	95			164							
LA65AN	90	14	31.5	126	196.2	76	70	M16×2×19	147	76	22	Rc1/8	19	13	63	55
LA65BN					256.2	120			207							

Notes: 1) LA Series does not have a ball retainer. Be aware that balls fall out when the ball slide is withdrawn from the rail.

Rail				Basic load rating						Weight			
Pitch	Mounting bolt hole	G	Max. length	² Dynamic		Static	Static moment (N-m)				Ball slide	Rail	
				[50km]	[100km]		C_0	M_{P0}		M_{V0}			
F	$d \times D \times h$	(reference)	L_{0max}	$C_{50}(N)$	$C_{100}(N)$	(N)	One slide	Two slides	One slide	Two slides	(kg)	(kg/m)	
60	7×11×9	20	3 960	30 000	23 900	50 000	290	410	2 490	410	2 490	0.6	3.7
				40 500	32 500	77 000	445	935	5 000	935	5 000	0.9	
80	9×14×12	20	4 000	47 000	37 000	77 500	535	820	4 800	820	4 800	0.9	5.8
				58 000	46 000	105 000	725	1 470	8 050	1 470	8 050	1.3	
80	9×14×12	20	4 000	61 500	49 000	98 000	845	1 130	6 750	1 130	6 750	1.5	7.7
				80 500	64 000	143 000	1 240	2 330	12 500	2 330	12 500	2.1	
105	14×20×17	22.5	3 990	91 000	72 000	148 000	1 840	2 210	12 900	2 210	12 900	3.0	12.0
				111 000	88 000	197 000	2 460	3 850	20 600	3 850	20 600	3.9	
120	16×23×20	30	3 960	139 000	111 000	215 000	3 150	3 800	22 000	3 800	22 000	4.7	17.2
				172 000	137 000	292 000	4 250	6 800	36 000	6 800	36 000	6.1	
150	18×26×22	35	3 900	260 000	206 000	420 000	7 300	9 050	51 000	9 050	51 000	7.7	25.9
				340 000	269 000	615 000	10 700	18 700	95 000	18 700	95 000	10.8	

2) The basic load rating comply with the ISO standard. (ISO 14728-1, 14728-2)

C_{50} : the basic dynamic load rating for 50 km rated fatigue life
 C_{100} : the basic dynamic load rating for 100 km rated fatigue life

LA-EL (High-load type / Standard)
LA-GL (Super-high-load type / Long)

LA 35 0840 EL C 2 - P6 3**

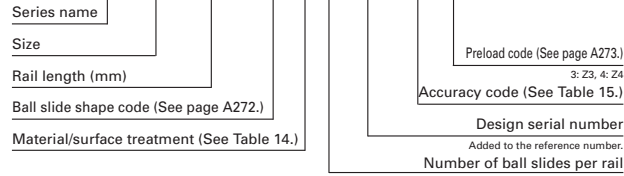

Front view of EL and GL types

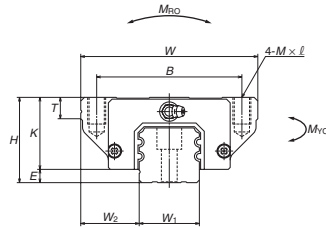

Side view of EL type

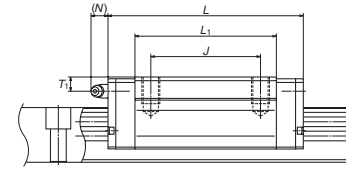

Side view of GL type

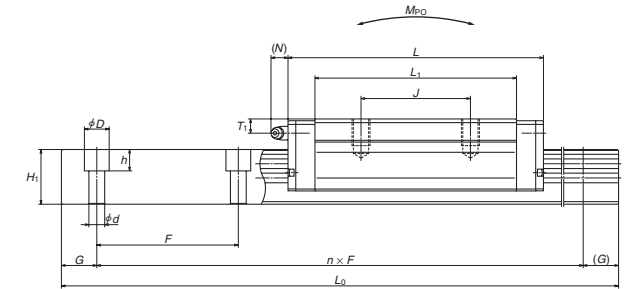

Unit: mm

Model No.	Assembly			Ball slide										Width	Height	
	Height	Width	Length	Mounting hole						Grease fitting						
				B	J	M × pitch × l	L ₁	K	T	Hole size	T ₁	N	W ₁			H ₁
H	E	W ₂	W	L	B	J	M × pitch × l	L ₁	K	T	Hole size	T ₁	N	W ₁	H ₁	
LA25EL	36	5.5	23.5	70	79.8	57	45	M8×1.25×12	58	30.5	11	M6×0.75	6	11	23	22
LA25GL					107.8				86							
LA30EL	42	7.5	31	90	100.2	72	52	M10×1.5×16	72	34.5	11	M6×0.75	6.5	11	28	28
LA30GL					126.2				98							
LA35EL	48	7.5	33	100	110.6	82	62	M10×1.5×15	80	40.5	12	M6×0.75	8	11	34	30.8
LA35GL					144.6				114							
LA45EL	60	10	37.5	120	141.4	100	80	M12×1.75×18	105	50	13	Rc1/8	10	13	45	36
LA45GL					173.4				137							
LA55EL	70	12	43.5	140	165.4	116	95	M14×2×21	126	58	15	Rc1/8	11	13	53	43.2
LA55GL					203.4				164							
LA65EL	90	14	53.5	170	196.2	142	110	M16×2×24	147	76	22	Rc1/8	19	13	63	55
LA65GL					256.2				207							

Notes: 1) LA Series does not have a ball retainer. Be aware that balls fall out when the ball slide is withdrawn from the rail.

Rail				Basic load rating						Weight			
Pitch	Mounting bolt hole	G	Max. length	²⁾ Dynamic		Static	Static moment (N·m)				Ball slide	Rail	
				[50km]	[100km]		C ₀	M _{P0}		M _{Y0}			
F	d × D × h	(reference)	L _{0max}	C ₅₀ (N)	C ₁₀₀ (N)	(N)	One slide	Two slides	One slide	Two slides	(kg)	(kg/m)	
60	7×11×9	20	3 960	30 000	23 900	50 000	290	410	2 490	410	2 490	0.8	3.7
				40 500	32 500	77 000	445	935	5 000	935	5 000	1.1	
80	9×14×12	20	4 000	47 000	37 000	77 500	535	820	4 800	820	4 800	1.3	5.8
				58 000	46 000	105 000	725	1 470	8 050	1 470	8 050	1.8	
80	9×14×12	20	4 000	61 500	49 000	98 000	845	1 130	6 750	1 130	6 750	1.9	7.7
				80 500	64 000	143 000	1 240	2 330	12 500	2 330	12 500	2.6	
105	14×20×17	22.5	3 990	91 000	72 000	148 000	1 840	2 210	12 900	2 210	12 900	3.3	12.0
				111 000	88 000	197 000	2 460	3 850	20 600	3 850	20 600	4.3	
120	16×23×20	30	3 960	139 000	111 000	215 000	3 150	3 800	22 000	3 800	22 000	5.5	17.2
				172 000	137 000	292 000	4 250	6 800	36 000	6 800	36 000	7.2	
150	18×26×22	35	3 900	260 000	206 000	420 000	7 300	9 050	51 000	9 050	51 000	11.0	25.9
				340 000	269 000	615 000	10 700	18 700	95 000	18 700	95 000	15.5	

2) The basic load rating comply with the ISO standard. (ISO 14728-1, 14728-2)

C₅₀: the basic dynamic load rating for 50 km rated fatigue life
C₁₀₀: the basic dynamic load rating for 100 km rated fatigue life

LA-FL (High-load type / Standard)
LA-HL (Super-high-load type / Long)

LA 35 0840 FL C 2 -** P6 3

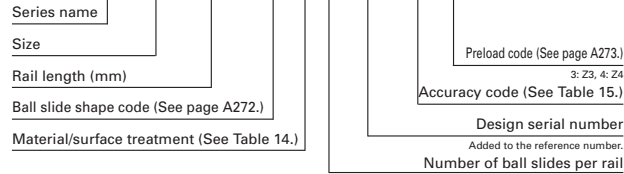

Front view of FL and HL types

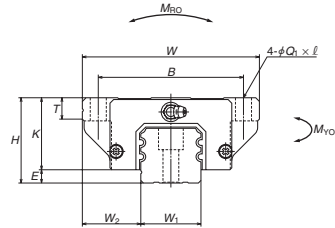

Side view of FL type

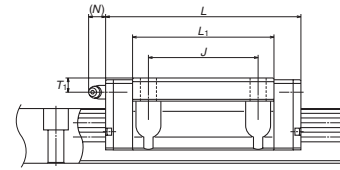

Side view of HL type

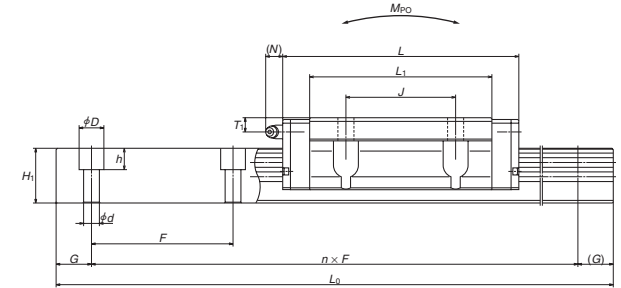

Model No.	Assembly			Ball slide											Width	Height		
	Height	E	W ₂	Width	Length	Mounting hole			L ₁	K	T	Grease fitting					W ₁	H ₁
						B	J	M × pitch × ℓ				Hole size	T ₁	N				
LA25FL	36	5.5	23.5	70	79.8	57	45	7×10	58	30.5	11	M6×0.75	6	11	23	22		
LA25HL					107.8				86									
LA30FL	42	7.5	31	90	100.2	72	52	9×12	72	34.5	11	M6×0.75	6.5	11	28	28		
LA30HL					126.2				98									
LA35FL	48	7.5	33	100	110.6	82	62	9×13	80	40.5	12	M6×0.75	8	11	34	30.8		
LA35HL					144.6				114									
LA45FL	60	10	37.5	120	141.4	100	80	11×15	105	50	13	Rc1/8	10	13	45	36		
LA45HL					173.4				137									
LA55FL	70	12	43.5	140	165.4	116	95	14×18	126	58	15	Rc1/8	11	13	53	43.2		
LA55HL					203.4				164									
LA65FL	90	14	53.5	170	196.2	142	110	16×23	147	76	22	Rc1/8	19	13	63	55		
LA65HL					256.2				207									

Notes: 1) LA Series does not have a ball retainer. Be aware that balls fall out when the ball slide is withdrawn from the rail.

Rail		Basic load rating								Weight			
Pitch	Mounting bolt hole	G	Max. length	²⁾ Dynamic		Static	Static moment (N·m)				Ball slide	Rail	
				[50km]	[100km]		C ₀	M _{P0}		M _{Y0}			
				F	d × D × h	(reference)		L _{0max}	C ₅₀ (N)	C ₁₀₀ (N)	(N)	One slide	Two slides
60	7×11×9	20	3 960	30 000	23 900	50 000	290	410	2 490	410	2 490	0.8	3.7
				40 500	32 500	77 000	445	935	5 000	935	5 000	1.1	
80	9×14×12	20	4 000	47 000	37 000	77 500	535	820	4 800	820	4 800	1.3	5.8
				58 000	46 000	105 000	725	1 470	8 050	1 470	8 050	1.8	
80	9×14×12	20	4 000	61 500	49 000	98 000	845	1 130	6 750	1 130	6 750	1.9	7.7
				80 500	64 000	143 000	1 240	2 330	12 500	2 330	12 500	2.6	
105	14×20×17	22.5	3 990	91 000	72 000	148 000	1 840	2 210	12 900	2 210	12 900	3.3	12.0
				111 000	88 000	197 000	2 460	3 850	20 600	3 850	20 600	4.3	
120	16×23×20	30	3 960	139 000	111 000	215 000	3 150	3 800	22 000	3 800	22 000	5.5	17.2
				172 000	137 000	292 000	4 250	6 800	36 000	6 800	36 000	7.2	
150	18×26×22	35	3 900	260 000	206 000	420 000	7 300	9 050	51 000	9 050	51 000	11.0	25.9
				340 000	269 000	615 000	10 700	18 700	95 000	18 700	95 000	15.5	

2) The basic load rating comply with the ISO standard. (ISO 14728-1, 14728-2)

C₅₀: the basic dynamic load rating for 50 km rated fatigue life
C₁₀₀: the basic dynamic load rating for 100 km rated fatigue life

1. HA Series**A291****2. HS Series****A305**

A-5-4 High-Precision Machine and High-Precision Measuring Equipment

A-5-4.1 HA Series



is received by four ball rows at all times. The number of the ball row which receives the load is larger than in other linear guides, making this series stronger against shock load.

(8) High accuracy at manufacturing

Fixing the measuring rollers to the ball grooves is easy thanks to the Gothic arch groove. Ball-groove measuring is accurate and simple. This benefits a highly precise and stable manufacturing.

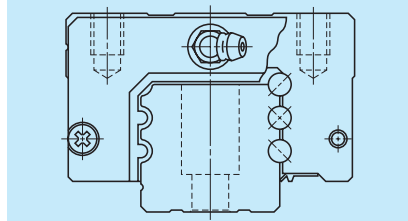

Fig. 1 HA Series

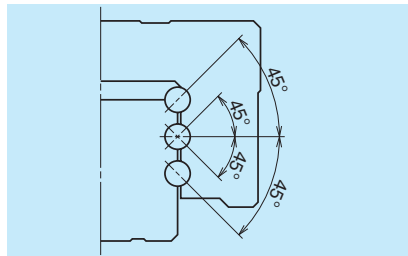

Fig. 2 Super rigidity design

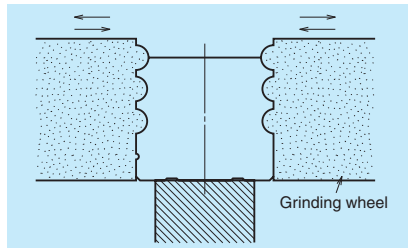

Fig. 3 Rail grinding

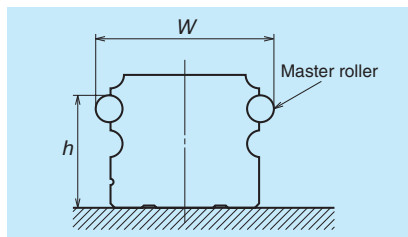

Fig. 4 Measuring groove accuracy

1. Features

(1) High motion accuracy

High motion accuracy is achieved in both narrow and wide ranges by the adoption of ultra-long ball slides and the optimum design of the ball recirculation component.

(2) Ball passage vibration reduced to one-third of our conventional models

Our extensive performance tests show ball passage vibration has been reduced to one-third of our conventional models, dramatically improving straightness in table unit.

(3) Installation of rail with greater accuracy

Increased counterbore depth of the rail mounting hole reduces rail deflection, which is caused by bolt tightening when fixing the rail to the mounting base to 50% or less. This feature restrains the pitching motion of ball slide whose frequency matches to the mounting hole pitch.

In addition, the length of mounting hole pitch has been reduced by one-half of the conventional models, so the rail can be more accurately installed in position.

(4) High rigidity and load capacity with lower friction

High rigidity, high load capacity and low friction are achieved by increasing the number of balls.

(5) Compact design

Reduced body size enables more compact machinery.

(6) Four-way equal load distribution

Contact angle is set at 45 degrees in all grooves, dispersing the load to four ball rows irrespective of load direction. This realizes equal rigidity and load carrying capacity in vertical and lateral directions and provides well-balanced design.

(7) Strong against shock load

Load from any direction, vertical and lateral,

Measurement results of ball passage vibration

Ball passage vibration can translate into posture changes in the ball slide which result from ball passage (circulation). In the HA Series, this vibration has been substantially reduced to one-third of conventional models.

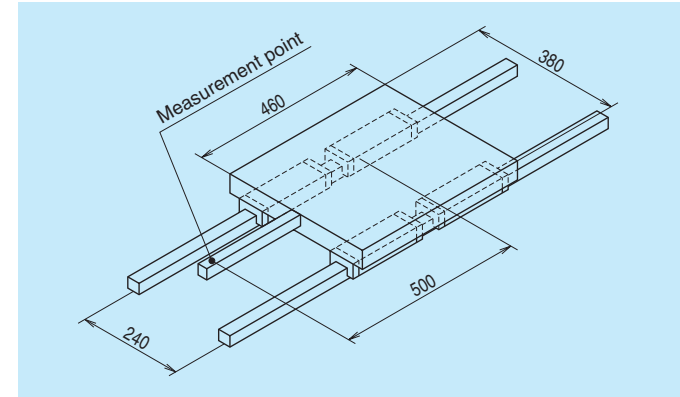
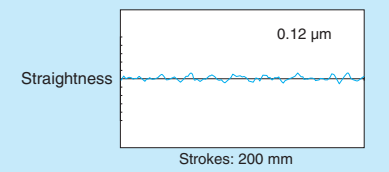
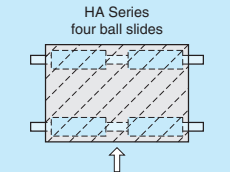

Fig. 5 Schematic view of measurement of ball passage vibration

HA Series

Model No.: HA30
Preload: Z3
Table dimensions: 460 mm x 380 mm



Conventional Series

Model No.: LA30
Preload: Z3
Table dimensions: 460 mm x 380 mm

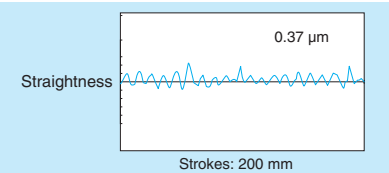
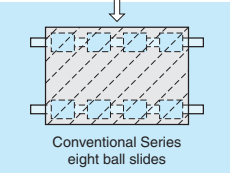

Fig. 6 Measurement results of HA Series and conventional Series

2. Ball slide shape

Ball slide Model	Shape/installation method	Type
AN		AN
AL		AL
EM		EM

3. Accuracy and preload

(1) Running parallelism of ball slide

Table 1 Unit: μm

Rail length (mm) over or less	Preloaded assembly		
	Ultra precision P3	Super precision P4	High precision P5
– 200	2	2	4
200 – 250	2	2.5	5
250 – 315	2	2.5	5
315 – 400	2	3	6
400 – 500	2	3	6
500 – 630	2	3.5	7
630 – 800	2	4.5	8
800 – 1 000	2.5	5	9
1 000 – 1 250	3	6	10
1 250 – 1 600	4	7	11
1 600 – 2 000	4.5	8	13
2 000 – 2 500	5	10	15
2 500 – 3 150	6	11	17
3 150 – 4 000	9	16	23

(2) Accuracy standard

Three accuracy grades are available: Ultra precision P3, Super precision P4 and High precision P5.

Table 2

Unit: μm

Characteristics	Ultra precision P3	Super precision P4	High precision P5
Mounting height H	± 10	± 10	± 20
Variation of H (All ball slides on a set of rails)	3	5	7
Mounting width W_2 or W_3 Variation of W_2 or W_3 (All ball slides on reference rail)	± 15 3	± 15 7	± 25 10
Running parallelism of surface C to surface A Running parallelism of surface D to surface B	Refer to Table 1 and Fig. 7		

(3) Assembled accuracy

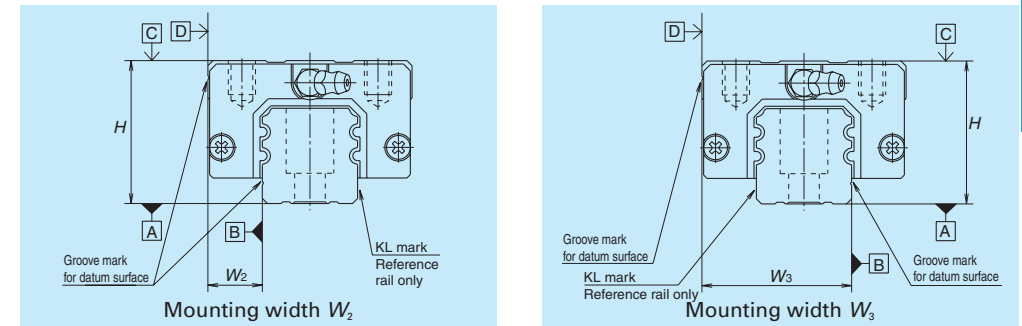

Fig. 7

(4) Preload and rigidity

Slight preload Z1 and Medium preload Z3 are available for preload, which can be selected for specific applications.

Table 3

Model No.	Preload (N)		Rigidity (N/ μm)	
	Slight preload (Z1)	Medium preload (Z3)	Slight preload (Z1)	Medium preload (Z3)
HA25	735	2 990	635	1 030
HA30	1 030	4 400	880	1 270
HA35	1 470	6 100	1 030	1 620
HA45	1 960	8 150	1 230	2 060
HA55	3 150	13 100	1 520	2 450

4. Maximum rail length

Table 4 shows the limitations of rail length.

However, the limitations vary by accuracy grades.

Table 4 Length limitations of rails

Unit: mm

Series	Size	25	30	35	45	55
HA		3 960	4 000	4 000	3 990	3 960

Note: Rails can be butted if user requirement exceeds the rail length shown in the table. Please consult NSK.

5. Installation

(1) Permissible values of mounting error

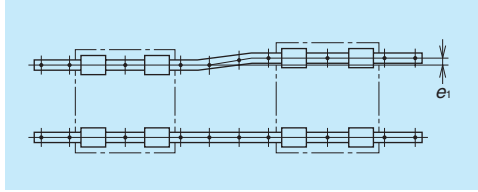

Fig. 8

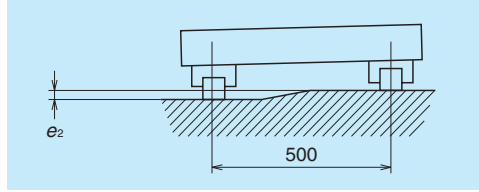

Fig. 9

Table 5

Unit: μm

Value	Preload	Model No.				
		HA25	HA30	HA35	HA45	HA55
Permissible values of parallelism in two rails e_1	Z1	20	20	23	26	34
	Z3	15	14	17	19	25
Permissible values of parallelism (height) in two rails e_2	Z1,Z3	250 μm /500 mm				

(2) Shoulder height of the mounting surface and corner radius

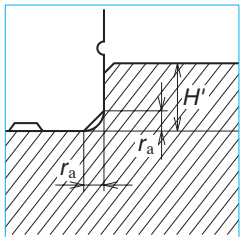

Fig. 10 Shoulder for the rail datum surface

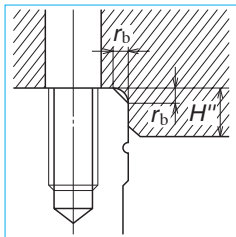

Fig. 11 Shoulder for the ball slide datum surface

Table 6

Unit: mm

Model No.	Corner radius (maximum)		Shoulder height	
	r_a	r_b	H'	H''
HA25	0.5	0.5	5	5
HA30	0.5	0.5	6	6
HA35	0.5	0.5	6	6
HA45	0.7	0.7	8	8
HA55	0.7	0.7	10	10

6. Lubrication components

Refer to pages A38 and D13 for linear guide lubrication.

(1) Types of lubrication accessories

Fig. 12 and Table 7 show grease fittings and tube fittings.

We provide lubrication accessories with extended thread body length (L) for the addition of dust-proof accessories such as NSK K1 lubrication unit, double seal and protector.

We provide a suitable lubrication accessory for the special requirement on dust-proof accessories.

Consult NSK for a lubrication accessory with extended length of thread body for your convenience of replenishing lubricant.

When you require stainless lubrication accessories, please ask NSK.

(2) Mounting position of lubrication accessories

The standard position of grease fittings is the end face of ball slide. We mount them on the side of end cap for an option.

Please consult NSK for installation of grease or tube fittings to the ball slide body or the side of end cap.

When using a piping unit with thread of M6 \times 1, you require a connector to connect to a grease fitting mounting hole with M6 \times 0.75. The connector is available from NSK.

Grease fitting

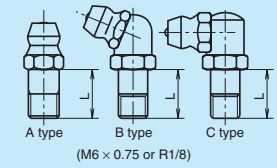

Tube fitting

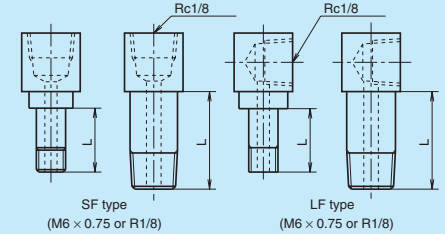

Fig. 12 Grease fitting and tube fitting

Table 7

Unit: mm

Model No.	Dust-proof specification	Dimension L		
		Grease fitting	Tube fitting	
			SF type	LF type
HA25	Standard	5	5	5
	With NSK K1	14	12	12
	Double seal	10	9	9
HA30	Protector	10	9	9
	Standard	5	6	6
	With NSK K1	14	12	13
HA35	Double seal	12	10	11
	Protector	12	11	11
	Standard	8	13.5	17
HA45	With NSK K1	18	22	21.5
	Double seal	14	18	17
	Protector	14	16	17
HA55	Standard	8	13.5	17
	With NSK K1	18	22	21.5
	Double seal	14	18	17
	Protector	14	16	17

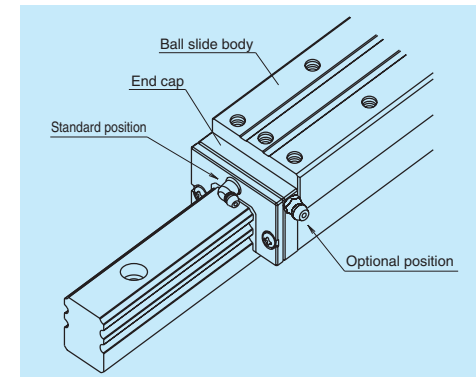

Fig. 13 Mounting position of lubrication accessories

7. Dust-proof components

(1) Standard Specification

The HA Series can be readily used as they have a dust protection means for normal conditions. As the standard equipment, the ball slides have an end seal on both ends, bottom seals at the bottom, and an inner seal in inside.

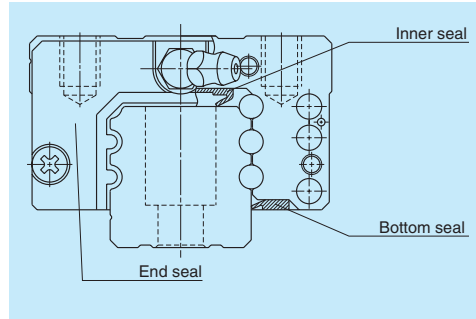

Fig. 14

Table 8 Seal friction per ball slide (maximum value)

		Unit: N				
Series	Size	25	30	35	45	55
HA		17	17	19	21	22

(2) NSK K1™ lubrication unit

Table 9 shows the dimensions of linear guides equipped with the NSK K1 lubrication unit.

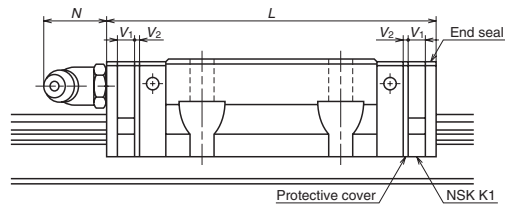

Table 9

Unit: mm

Model No.	Ball slide model	Standard ball slide length	Ball slide length installed with two NSK K1 L	Per NSK K1 thickness V ₁	Protective cover thickness V ₂	Protruding area of the grease fitting N
HA25	AN, EM	147.8	159.8	5.0	1.0	(14)
HA30	AN, EM	177.2	190.2	5.5	1.0	(14)
HA35	AN, AL, EM	203.6	216.6	5.5	1.0	(14)
HA45	AN, AL, EM	233.4	248.4	6.5	1.0	(15)
HA55	AN,AL, EM	284.4	299.4	6.5	1.0	(15)

Note: Ball slide length equipped with NSK K1 = (Standard ball slide length) + (Thickness of NSK K1, V₁ × Number of NSK K1) + (Thickness of the protective cover V₂ × 2)

(3) Double seal and protector

For the HA Series, double seal and protectors can be installed only before shipping from the factory. Please consult with NSK when you require dust tight protection.

Table 10 shows the increased thickness of V₃ and V₄ when the end seal and the protector are installed.

Table 10

Unit: mm

Model No.	Thickness of end seal: V ₃	Thickness of protector: V ₄
HA25	3.2	3.6
HA30	4.4	4.2
HA35	4.4	4.2
HA45	5.5	4.9
HA55	5.5	4.9

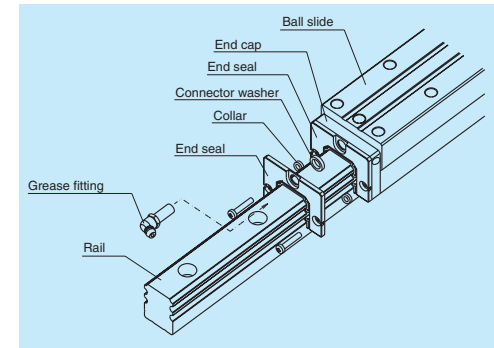

Fig. 15 Double seal

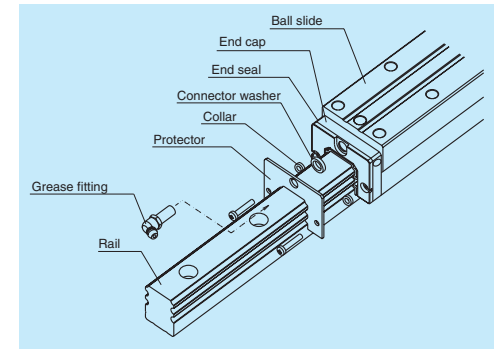

Fig. 16 Protector

(4) Caps to plug the rail mounting bolt hole

Table 11 Caps to plug rail bolt hole

Model No.	Bolt to secure rail	Cap reference No.	Quantity /case
HA25	M6	LG-CAP/M6	20
HA30, HA35	M8	LG-CAP/M8	20
HA45	M12	LG-CAP/M12	20
HA55	M14	LG-CAP/M14	20

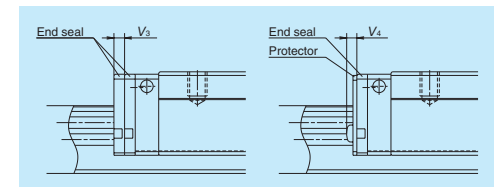

Fig. 17

8. Reference number

Reference numbers shall be set to individual NSK linear guide when its specifications are finalized, and it is indicated on its specification drawing.
Please specify the reference number, except design serial number, to identify the product when ordering, requiring estimates, or inquiring about specifications from NSK.

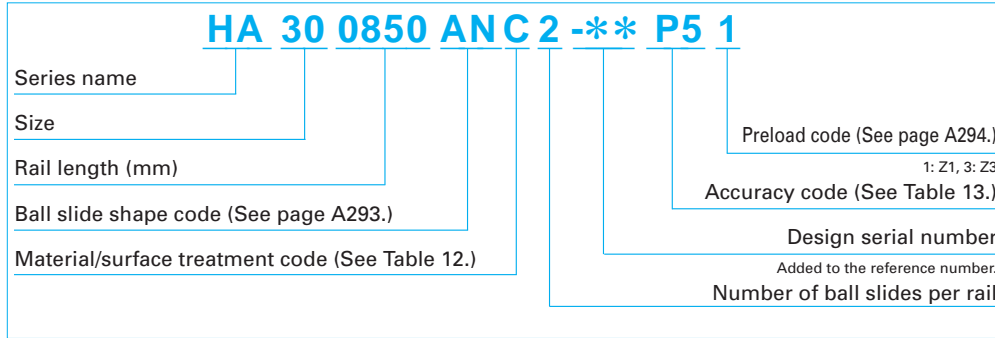

Table 12 Material/surface treatment code

Code	Description
C	Special high carbon steel (NSK standard)
D	Special high carbon steel with surface treatment
Z	Other, special

Table 13 Accuracy code

Accuracy	Standard (Without NSK K1)	With NSK K1
Ultra precision grade	P3	K3
Super precision grade	P4	K4
High precision grade	P5	K5

Note: Refer to page A38 for NSK K1 lubrication unit.

9. Dimensions
HA-AN
HA-AL

HA 30 0850 ANC 2 - P5 1**

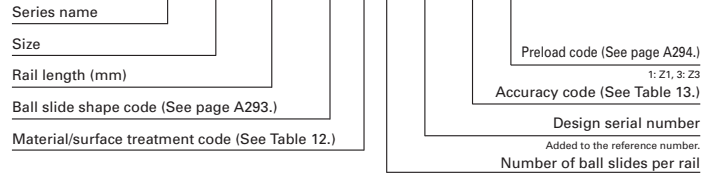

Front view of AL type

Side view of AL type

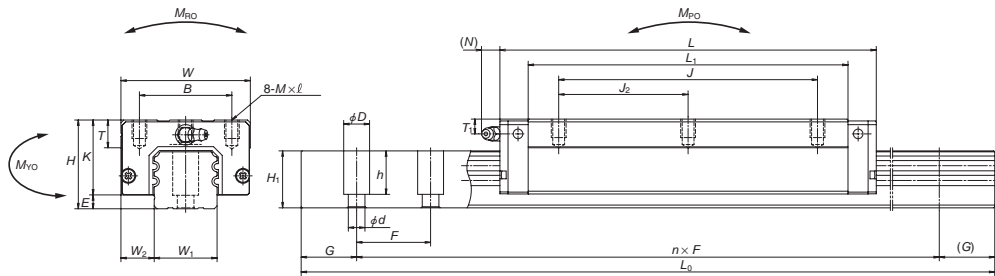

Front view of AN type

Side view of AN type

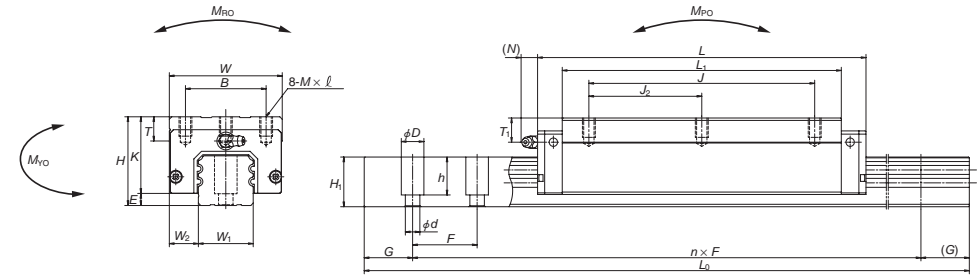

Model No.	Assembly			Ball slide										Rail			
	Height H	E	W ₂	Width W	Length L	Mounting hole					Grease fitting					Width W ₁	Height H ₁
						B	J	J ₂	M × pitch × l	L ₁	K	T	Hole size	T ₁	N		
HA25AN	40	5.5	12.5	48	147.8	35	100	50	M6×1.0×10	126	34.5	12	M6×0.75	10	11	23	22
HA30AN	45	7.5	16	60	177.2	40	120	60	M8×1.25×11	149	37.5	14	M6×0.75	9.5	11	28	28
HA35AN HA35AL	55 48	7.5	18	70	203.6	50	140	70	M8×1.25×12 M8×1.25×10	173	47.5 40.5	15	M6×0.75	15 8	11	34	30.8
HA45AN HA45AL	70 60	10	20.5	86	233.4	60	160	80	M10×1.5×16	197	60 50	17	Rc1/8	20 10	13	45	36
HA55AN HA55AL	80 70	12	23.5	100	284.4	75	206	103	M12×1.75×18 M12×1.75×16	245	68 58	18	Rc1/8	21 11	13	53	43.2

Notes: 1) The HA Series does not have a ball retainer. Be aware that the balls fall out when a ball slide is withdrawn from the rail.

Unit: mm

Rail				Basic load rating								Weight	
Pitch F	Mounting bolt hole d × D × h	G (reference)	Maximum length L _{0max}	²⁾ Dynamic		Static C ₀ (N)	M _{RO}	Static moment (N·m)				Ball slide (kg)	Rail (kg/m)
				[50km] C ₅₀ (N)	[100km] C ₁₀₀ (N)			One slide		Two slides			
30	7×11×16.5	20	3 960	54 000	43 000	115 000	670	2 060	10 100	2 060	10 100	1.2	3.7
40	9×14×21	20	4 000	79 500	63 500	166 000	1 140	3 550	17 400	3 550	17 400	1.8	5.8
40	9×14×23.5	20	4 000	111 000	88 000	226 000	1 950	5 650	27 100	5 650	27 100	3.0 2.6	7.7
52.5	14×20×27	22.5	3 990	147 000	117 000	295 000	3 700	8 450	40 500	8 450	40 500	6.0 5.0	12.0
60	16×23×32.5	30	3 960	232 000	184 000	445 000	6 500	15 400	75 000	15 400	75 000	9.4 7.8	17.2

2) The basic load rating comply with the ISO standard. (ISO 14728-1, 14728-2)

C₅₀: the basic dynamic load rating for 50 km rated fatigue life C₁₀₀: the basic dynamic load rating for 100 km rated fatigue life

HA-EM

HA 30 0850 EMC 2 - P5 1**

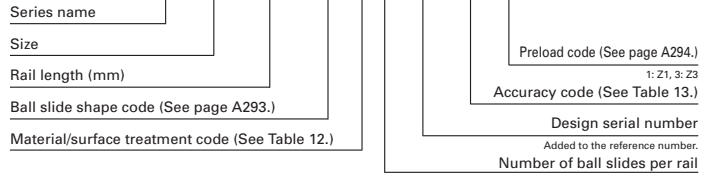

Front view of EM type

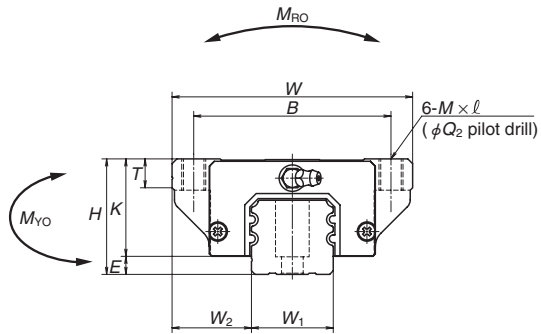

Side view of EM type

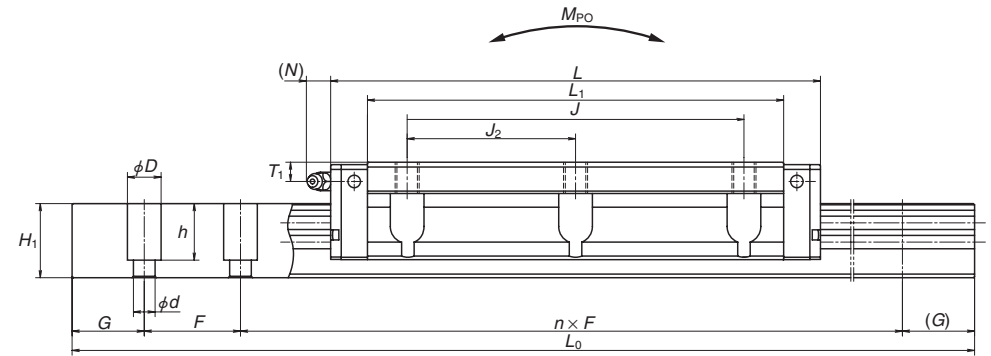

Model No.	Assembly			Ball slide										Rail				
	Height H	E	W ₂	Width W	Length L	Mounting hole					L ₁	K	T	Grease fitting			Width W ₁	Height H ₁
						B	J	J ₂	M × pitch × l	Q ₂				Hole size	T ₁	N		
HA25EM	36	5.5	23.5	70	147.8	57	100	50	M8×1.25×10	6.8	126	30.5	11	M6×0.75	6	11	23	22
HA30EM	42	7.5	31	90	177.2	72	120	60	M10×1.5×12	8.6	149	34.5	11	M6×0.75	6.5	11	28	28
HA35EM	48	7.5	33	100	203.6	82	140	70	M10×1.5×13	8.6	173	40.5	12	M6×0.75	8	11	34	30.8
HA45EM	60	10	37.5	120	233.4	100	160	80	M12×1.75×15	10.5	197	50	13	Rc1/8	10	13	45	36
HA55EM	70	12	43.5	140	284.4	116	206	103	M14×2×18	12.5	245	58	15	Rc1/8	11	13	53	43.2

Notes: 1) HA Series does not have a ball retainer. Be aware that the balls fall out when a ball slide is withdrawn from the rail.

Unit: mm

Pitch F	Mounting bolt hole d × D × h	G (reference)	Maximum length L _{0max}	Basic load rating						Weight			
				²⁾ Dynamic		Static C ₀ (N)	Static moment (N·m)				Ball slide (kg)	Rail (kg/m)	
				[50km] C ₅₀ (N)	[100km] C ₁₀₀ (N)		M _{RO}	M _{PO}		M _{YO}			
30	7×11×16.5	20	3 960	54 000	43 000	115 000	670	2 060	10 100	2 060	10 100	1.6	3.7
40	9×14×21	20	4 000	79 500	63 500	166 000	1 140	3 550	17 400	3 550	17 400	2.6	5.8
40	9×14×23.5	20	4 000	111 000	88 000	226 000	1 950	5 650	27 100	5 650	27 100	3.8	7.7
52.5	14×20×27	22.5	3 990	147 000	117 000	295 000	3 700	8 450	40 500	8 450	40 500	6.6	12.0
60	16×23×32.5	30	3 960	232 000	184 000	445 000	6 500	15 400	75 000	15 400	75 000	11	17.2

2) The basic load rating comply with the ISO standard. (ISO 14728-1, 14728-2)

C₅₀: the basic dynamic load rating for 50 km rated fatigue life C₁₀₀: the basic dynamic load rating for 100 km rated fatigue life

A-5-4.2 HS Series



1. Features

(1) High motion accuracy

High motion accuracy is achieved in both narrow and wide ranges by adopting ultra-long ball slides and optimum design features for the ball recirculation component.

(2) Ball passage vibration reduced to one-third of our conventional models

Tests show ball passage vibration has been reduced to one-third of our conventional models, dramatically improving straightness in table unit.

(3) Installation of rail with greater accuracy

Increased counterbore depth of the rail mounting hole reduces rail deflection, which is caused by bolt tightening when fixing the rail to the mounting base, to 50% or less. This feature restrains the pitching motion of ball slide whose frequency matches to the mounting hole pitch.

In addition, the mounting hole pitch has been reduced by one-half of the conventional models, so the rail can be more accurately installed in position.

(4) High rigidity and load capacity with lower friction

High rigidity, high load capacity and low friction are achieved by increasing the number of balls.

(5) Compact design

Reduced body size enables more compact machinery.

(6) High load carrying capacity to vertical direction

The contact angle is set at 50 degrees, increasing load carrying capacity as well as rigidity against the load in vertical direction.

(7) High resistance against impact load

The bottom ball groove is formed in Gothic arch and the center of the top and bottom grooves are offset as shown in Fig. 2. The vertical load is usually carried by top two ball rows at where balls are contacting at two points. Because of this design, the bottom ball rows will carry the load when a large impact load is applied as shown in Fig. 3. This

assures high resistance to the impact load.

(8) High accuracy at manufacturing

As showing in Fig. 4, fixing the measuring rollers to the ball groove is easy thanks to the Gothic arch groove. This makes easy and accurate measuring of ball grooves.

(9) Improve rating life dramatically

New ball groove geometry is introduced, which has been developed by utilizing NSK's state-of-the-art tribological and analytical technologies. Due to the optimized distribution of contact surface pressures, the rating life has dramatically increased.

As compared with the conventional products, the load rating capacity has increased to 1.3 times, while the life span has increased to twice^{*1}.

*1: Representative values of series.

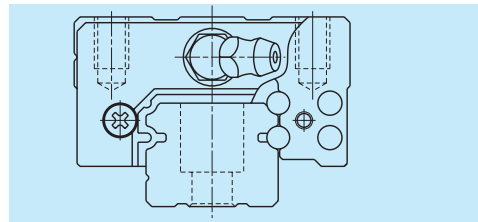

Fig. 1 HS Series

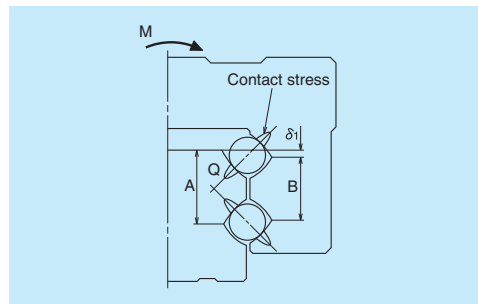

Fig. 2 Enlarged illustration: Offset Gothic arch

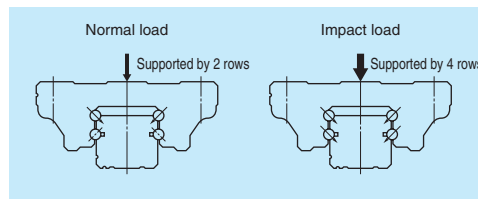

Fig. 3 When load is applied

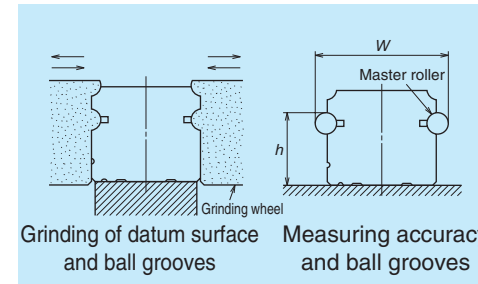

Fig. 4 Rail-grinding and measuring

Measurement results of ball passage vibration

Ball passage vibration can translate into posture changes in the ball slide which result from ball passage (circulation). In the HS Series, this vibration has been substantially reduced to one-third of conventional models.

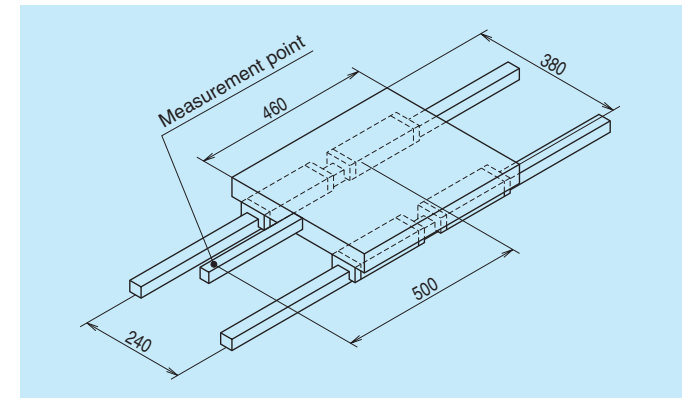
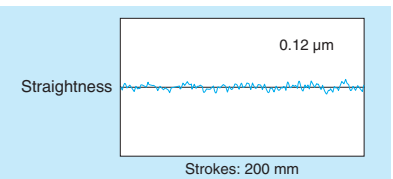
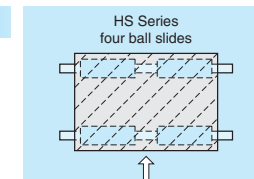

Fig. 5 Schematic view of measurement of ball passage vibration

HS Series

Model No.: HS30
Preload: Z1
Table dimensions: 460 mm x 380 mm



Conventional Series

Model No.: LS30
Preload: Z1
Table dimensions: 460 mm x 380 mm

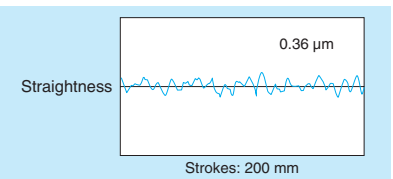
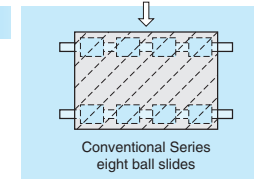

Fig. 6 Measurement results of HS Series and conventional Series

2. Ball slide shape

Ball slide Model	Shape/installation method	Type
AL		
EM		

3. Accuracy and preload

(1) Running parallelism of ball slide

Table 1 Unit: μm

Rail length (mm)		Preloaded assembly		
		Ultra precision P3	Super precision P4	High precision P5
over	or less			
-	200	2	2	4
200	- 250	2	2.5	5
250	- 315	2	2.5	5
315	- 400	2	3	6
400	- 500	2	3	6
500	- 630	2	3.5	7
630	- 800	2	4.5	8
800	- 1 000	2.5	5	9
1 000	- 1 250	3	6	10
1 250	- 1 600	4	7	11
1 600	- 2 000	4.5	8	13
2 000	- 2 500	5	10	15
2 500	- 3 150	6	11	17
3 150	- 4 000	9	16	23

(2) Accuracy Standard

Three accuracy grades are available: Ultra precision P3, Super precision P4 and High precision P5.

Unit: μm

Characteristics	Table 2		
	Ultra precision P3	Super precision P4	High precision P5
Mounting height H Variation of H (All ball slides on a set of rails)	± 10 3	± 10 5	± 20 7
Mounting width W_2 or W_3 Variation of W_2 or W_3 (All ball slides on reference rail)	± 15 3	± 15 7	± 25 10
Running parallelism of surface C to surface A Running parallelism of surface D to surface B	Refer to Table 1 and Fig. 7		

(3) Assembled accuracy

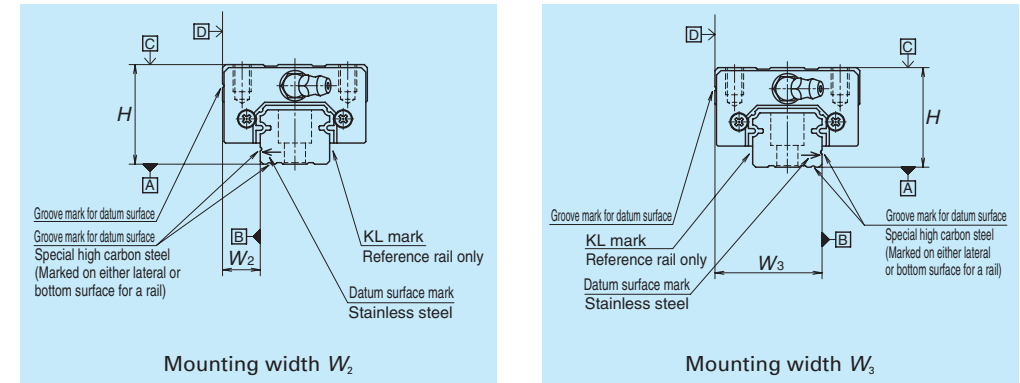

Fig. 7

(4) Preload and rigidity

Slight preload Z1 and Medium preload Z3 are available for preload, which can be selected for specific applications.

Table 3

Model No.	Preload (N)		Rigidity (N/ μm)			
			Vertical direction		Lateral direction	
	Slight preload (Z1)	Medium preload (Z3)	Slight preload (Z1)	Medium preload (Z3)	Slight preload (Z1)	Medium preload (Z3)
HS15	98	785	260	530	173	355
HS20	147	1 030	305	600	212	415
HS25	245	1 620	385	735	263	505
HS30	390	2 550	505	965	345	665
HS35	590	3 550	610	1 140	415	780

4. Maximum rail length

Table 4 shows the limitation. The dimension in parenthesis is for stainless steel products. However, the limitations vary by accuracy grades.

Table 4 Length limitation of rails

Unit: mm

Series	Size	15	20	25	30	35
HS		2 000 (1 800)	3 960 (3 500)	3 960 (3 500)	4 000 (3 500)	4 000 (3 500)

Note: Rails can be butted if user requirement exceeds the rail length shown in the table. Please consult NSK.

5. Installation

(1) Permissible values of mounting error

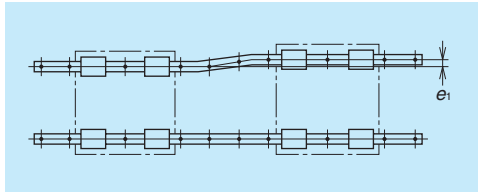

Fig. 8

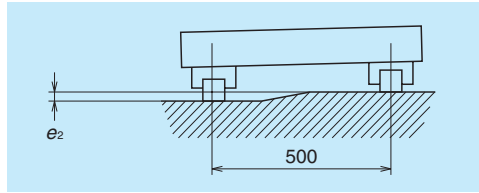

Fig. 9

Table 5

Unit: μm

Value	Preload	Model No.				
		HS15	HS20	HS25	HS30	HS35
Permissible values of parallelism in two rails e_1	Z1	18	20	26	31	37
	Z3	12	14	18	22	26
Permissible values of parallelism (height) in two rails e_2	Z1, Z3	330 $\mu\text{m}/500\text{ mm}$				

(2) Shoulder height of the mounting surface and corner radius r

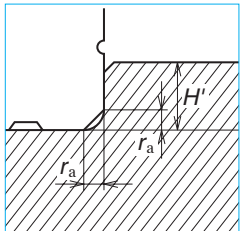

Fig. 10 Shoulder for the rail datum surface

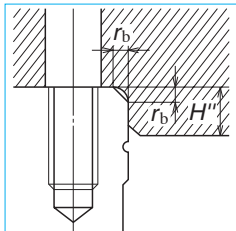

Fig. 11 Shoulder for the ball slide datum surface

Table 6

Unit: mm

Model No.	Corner radius (maximum)		Shoulder height	
	r_a	r_b	H'	H''
HS15	0.5	0.5	4	4
HS20	0.5	0.5	4.5	5
HS25	0.5	0.5	5	5
HS30	0.5	0.5	6	6
HS35	0.5	0.5	6	6

6. Lubrication components

Refer to pages A38 and D13 for linear guide lubrication.

(1) Types of lubrication accessories

Fig. 12 and Table 7 show grease fittings and tube fittings.

We provide lubrication accessories with extended thread body length (L) for the addition of dust-proof accessories such as NSK K1 lubrication unit, double seal and protector.

We provide a suitable lubrication accessory for the special requirement on dust-proof accessories.

Consult NSK for a lubrication accessory with extended length of thread body for your convenience of replenishing lubricant.

When you require stainless lubrication accessories, please ask NSK.

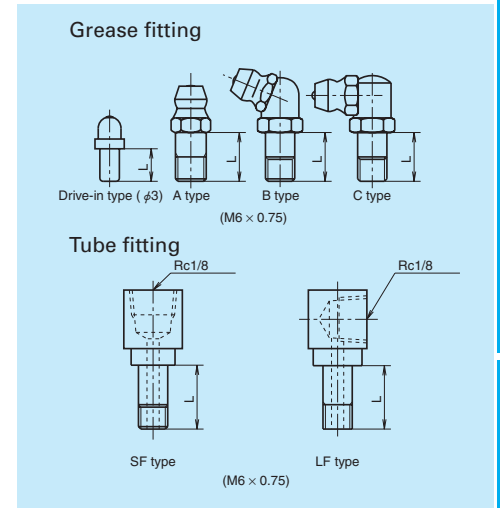

Fig. 12 Grease fitting and tube fitting

(2) Mounting position of lubrication accessories

The standard position of grease fittings is the end face of ball slide. We mount them on the side of end cap for an option. (Fig. 13)

Please consult NSK for installation of grease or tube fittings to the ball slide body or the side of end cap.

When using a piping unit with thread of M6 \times 1, you require a connector to connect to a grease fitting mounting hole with M6 \times 0.75. The connector is available from NSK.

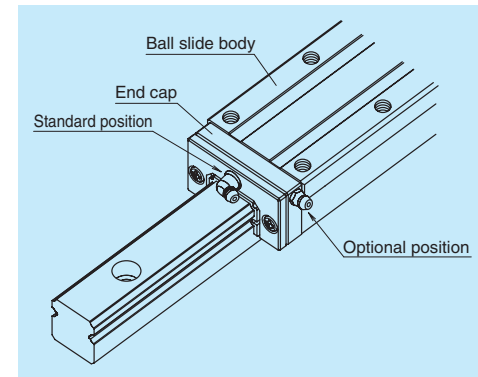

Fig. 13 Mounting position of lubrication accessories

Table 7

Unit: mm

Model No.	Dust-proof specification	Dimension L		
		Grease fitting / Drive-in type	Tube fitting	
			SF type	LF type
HS15	Standard	5	-	-
	With NSK K1	10	-	-
	Double seal	*	-	-
HS20	Standard	5	-	-
	With NSK K1	10	-	-
	Double seal	8	-	-
HS25	Standard	5	6	6
	With NSK K1	12	11	11
	Double seal	10	9	9
HS30	Standard	5	6	6
	With NSK K1	14	12	13
	Double seal	12	10	11
HS35	Standard	5	6	6
	With NSK K1	14	12	13
	Double seal	12	10	11

*) A connector is required for this model. Please contact NSK.

7. Dust-proof components

(1) Standard Specification

The HS Series can be readily used as they have a dust protection means for normal conditions. As the standard equipment, the ball slides have an end seal on both ends.

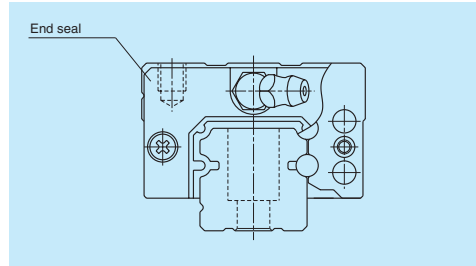

Fig. 14

Table 8 Seal friction per ball slide (maximum): end seal only

		Unit: N				
Series	Size	15	20	25	30	35
HS		3	3	3	3	4

(2) NSK K1™ lubrication unit

Refer to **Table 9** for dimension of linear guides equipped with the NSK K1 lubrication unit.

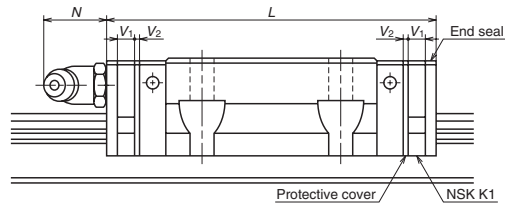

Table 9

		Unit: mm				
Model No.	Ball slide model	Standard ball slide length	Ball slide length installed with two NSK K1 L	Per NSK K1 thickness V ₁	Protective cover thickness V ₂	Protruding area of the grease fitting N
HS15	AL, EM	106	115.6	4.0	0.8	(5)
HS20	AL, EM	119.7	130.3	4.5	0.8	(14)
HS25	AL, EM	148	158.6	4.5	0.8	(14)
HS30	AL, EM	176.1	188.1	5.0	1.0	(14)
HS35	AL, EM	203.6	216.6	5.5	1.0	(14)

Note: Ball slide length equipped with NSK K1 = (Standard ball slide length) + (Thickness of NSK K1, V₁ × Number of NSK K1) + (Thickness of the protective cover V₂ × 2)

(3) Double seal and protector

For the HS Series, double seal and protectors can be installed only before shipping from the factory. Please consult with NSK when you require dust tight protection.

Table 10 shows the increased thickness of V₃ and V₄ when the end seal and the protector are installed.

Table 10

Unit: mm

Model No.	Thickness of end seal: V ₃	Thickness of protector: V ₄
HS15	2.8	3
HS20	2.5	2.7
HS25	2.8	3.2
HS30	3.6	4.2
HS35	3.6	4.2

(4) Caps to plug the rail mounting bolt hole

Table 11 Caps to plug rail bolt hole

Model No.	Bolt to secure rail	Cap reference No.	Quantity /case
HS15	M3	LG-CAP/M3	20
HS15	M4	LG-CAP/M4	20
HS20	M5	LG-CAP/M5	20
HS25, HS30	M6	LG-CAP/M6	20
HS35	M8	LG-CAP/M8	20

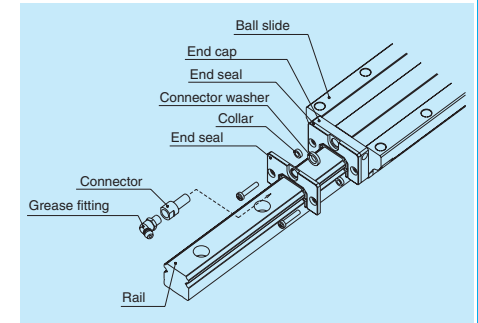

Fig. 15 Double seal

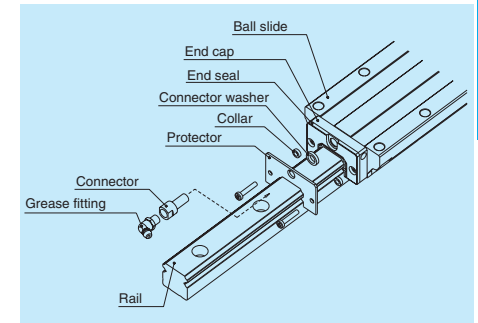

Fig. 16 Protector

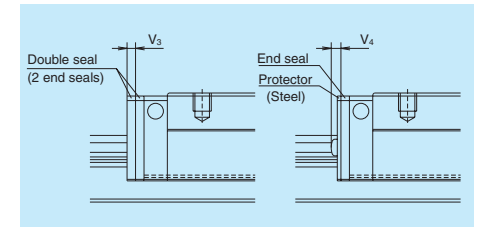

Fig. 17

8. Reference number

Reference numbers shall be set to individual NSK linear guide when its specifications are finalized, and it is indicated on its specification drawing.

Please specify the reference number, except design serial number, to identify the product when ordering, requiring estimates, or inquiring about specifications from NSK.

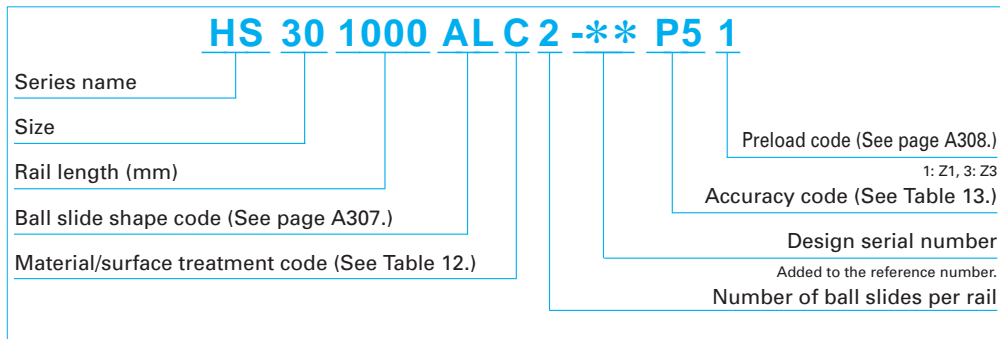

Table 12 Material/surface treatment code

Code	Description
C	Special high carbon steel (NSK standard)
K	Stainless steel
D	Special high carbon steel with surface treatment
H	Stainless steel with surface treatment
Z	Other, special

Table 13 Accuracy code

Accuracy	Standard (Without NSK K1)	With NSK K1
Ultra precision grade	P3	K3
Super precision grade	P4	K4
High precision grade	P5	K5

Note: Refer to page A38 for NSK K1 lubrication unit.

9. Dimensions
HS-AL

HS 30 1000 AL C 2 - P5 1**

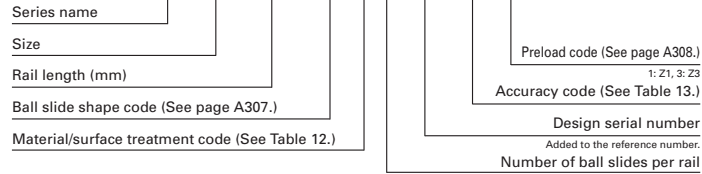

Front view of AL types

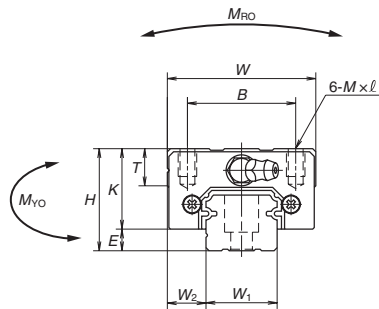

Side view of AL type

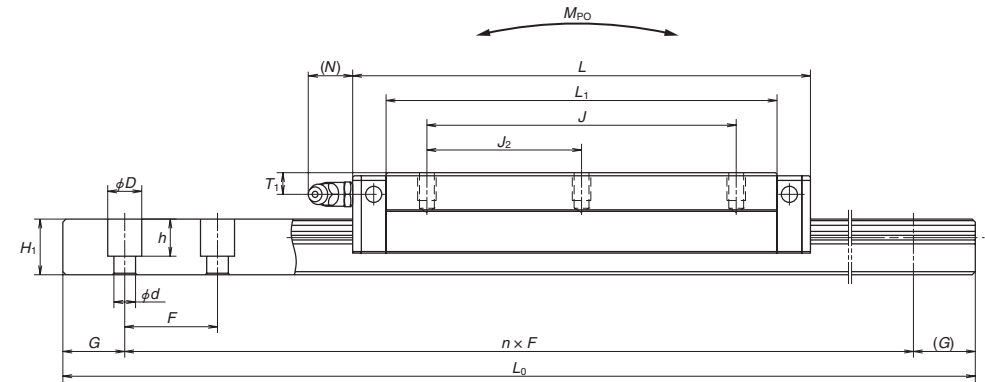

Model No.	Assembly			Ball slide										Width	Height		
	Height	E	W ₂	Width	Length	Mounting hole				L ₁	K	T	Grease fitting				
						B	J	J ₂	M × pitch × l				Hole size			T ₁	N
HS15AL	24	4.6	9.5	34	106	26	60	30	M4×0.7×6	89.2	19.4	10	φ 3	6	3	15	12.5
HS20AL	28	6	11	42	119.7	32	80	40	M5×0.8×7	102.5	22	12	M6×0.75	5.5	11	20	15.5
HS25AL	33	7	12.5	48	148	35	100	50	M6×1×9	126.4	26	12	M6×0.75	7	11	23	18
HS30AL	42	9	16	60	176.1	40	120	60	M8×1.25×12	150.7	33	13	M6×0.75	8	11	28	23
HS35AL	48	10.5	18	70	203.6	50	140	70	M8×1.25×12	175.6	37.5	14	M6×0.75	8.5	11	34	27.5

Notes: 1) The HS Series does not have a ball retainer. Be aware that balls fall out when the ball slide is withdrawn from the rail.
2) External appearance of stainless steel ball slides differ from those of carbon steel ball slide.

Rail		Basic load rating									Weight		
Pitch	Mounting bolt hole	G	Max. length L _{max} () for stainless	Dynamic		Static C ₀ (N)	M _{RO}	Static moment (N·m)				Ball slide (kg)	Rail (kg/m)
				[50km] C ₅₀ (N)	[100km] C ₁₀₀ (N)			M _{PO}		M _{YO}			
30	*3.5×6×8.5 4.5×7.5×8.5	20	2 000 (1 800)	20 500	16 300	40 000	199	M _{PO}		M _{YO}		0.34	1.4
								One slide	Two slides	One slide	Two slides		
30	6×9.5×10.5	20	3 960 (3 500)	27 300	21 600	52 000	350	590	2 930	495	2 460	0.52	2.3
30	7×11×12	20	3 960 (3 500)	44 500	35 000	78 000	605	1 090	5 450	910	4 600	0.85	3.1
40	7×11×16	20	4 000 (3 500)	68 000	54 000	127 000	1 190	2 120	10 600	1 780	8 850	1.7	4.8
40	9×14×20	20	4 000 (3 500)	94 500	75 000	172 000	1 980	3 350	16 600	2 820	13 900	2.5	7.0

3) The basic load rating comply with the ISO standard. (ISO 14728-1, 14728-2)
C₅₀: the basic dynamic load rating for 50 km rated fatigue life C₁₀₀: the basic dynamic load rating for 100 km rated fatigue life
The basic static load rating shows static permissible load.

4) Parenthesized dimensions are applicable to stainless steel products.

* Standard rail mounting bolt hole for HS15 is specified as hole for M3 (3.5 × 6 × 8.5). Please contact us to request a different hole for M4 (4.5 × 7.5 × 8.5).

HS-EM

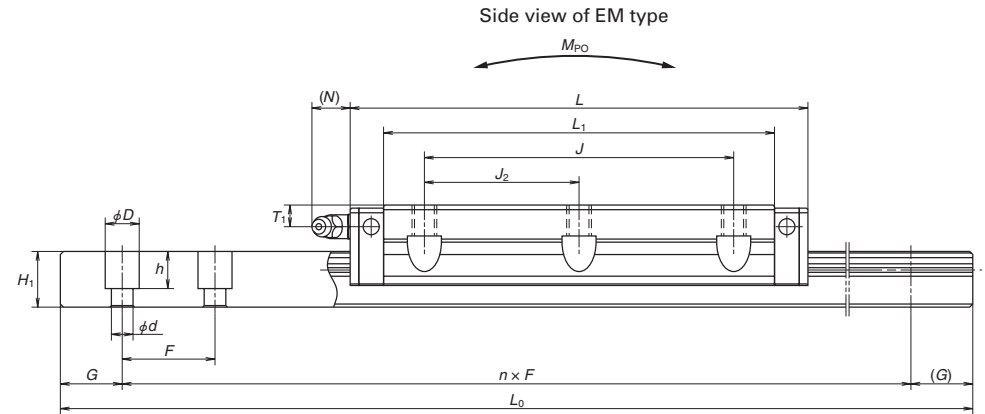
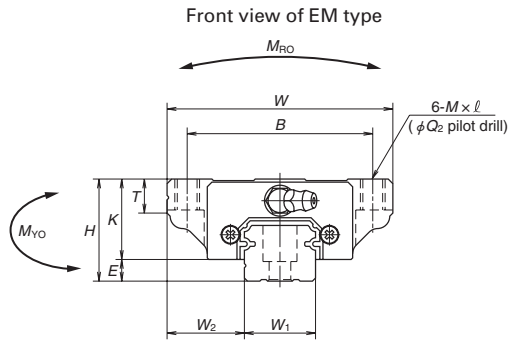
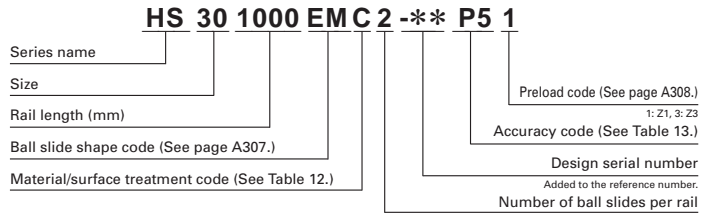

Model No.	Assembly			Ball slide														
	Height H	E	W ₂	Width W	Length L	Mounting hole						Grease fitting			Width W ₁	Height H ₁		
						B	J	J ₂	M × pitch × ℓ	Q ₂	L ₁	K	T	Hole size			T ₁	N
HS15EM	24	4.6	18.5	52	106	41	60	30	M5×0.8×7	4.4	89.2	19.4	8	φ 3	6	3	15	12.5
HS20EM	28	6	19.5	59	119.7	49	80	40	M6×1×9 (M6×1×9.5)	5.3	102.5	22	10	M6×0.75	5.5	11	20	15.5
HS25EM	33	7	25	73	148	60	100	50	M8×1.25×10 (M8×1.25×11.5)	6.8	126.4	26	11 (12)	M6×0.75	7	11	23	18
HS30EM	42	9	31	90	176.1	72	120	60	M10×1.5×12 (M10×1.5×14.5)	8.6	150.7	33	11 (15)	M6×0.75	8	11	28	23
HS35EM	48	10.5	33	100	203.6	82	140	70	M10×1.5×13 (M10×1.5×14.5)	8.6	175.6	37.5	12 (15)	M6×0.75	8.5	11	34	27.5

Notes: 1) The HS Series does not have a ball retainer. Be aware that balls fall out when the ball slide is withdrawn from the rail.
 2) External appearance of stainless steel ball slides differ from those of carbon steel ball slide.

Unit: mm

Rail		Basic load rating									Weight		
Pitch F	Mounting bolt hole d × D × h	G (reference)	Max. length L _{gmax} () for stainless	Dynamic		Static C ₀ (N)	Static moment (N·m)				Ball slide (kg)	Rail (kg/m)	
				[50km] C ₅₀ (N)	[100km] C ₁₀₀ (N)		M _{RO}	M _{PO}		M _{YO}			
30	*3.5×6×8.5 4.5×7.5×8.5	20	2 000 (1 800)	20 500	16 300	40 000		199	395	1 990	335	1 670	0.45
30	6×9.5×10.5	20	3 960 (3 500)	27 300	21 600	52 000	350	590	2 930	495	2 460	0.67	2.3
30	7×11×12	20	3 960 (3 500)	44 500	35 000	78 000	605	1 090	5 450	910	4 600	1.3	3.1
40	7×11×16	20	4 000 (3 500)	68 000	54 000	127 000	1 190	2 120	10 600	1 780	8 850	2.4	4.8
40	9×14×20	20	4 000 (3 500)	94 500	75 000	172 000	1 980	3 350	16 600	2 820	13 900	3.4	7.0

3) The basic load rating comply with the ISO standard. (ISO 14728-1, 14728-2)
 C₅₀: the basic dynamic load rating for 50 km rated fatigue life C₁₀₀: the basic dynamic load rating for 100 km rated fatigue life
 The basic static load rating shows static permissible load.
 4) Parenthesized dimensions are applicable to stainless steel products.
 *) Standard rail mounting bolt hole for HS15 is specified as hole for M3 (3.5 × 6 × 8.5). Please contact us to request a different hole for M4 (4.5 × 7.5 × 8.5).

5. The Comparative Table of New and Former Series

New Series				Former series				
Model No.	Ball slide mounting hole dimension Mxpitchxℓ <Q> [mm]	Dynamic load rating C ₀ [N]	Model No.	Ball slide mounting hole dimension Mxpitchxℓ <Q> Q,ℓ [mm]	Dynamic load rating C ₀ [N]	Model No.	Ball slide mounting hole dimension Mxpitchxℓ <Q> Q,ℓ [mm]	Dynamic load rating C ₀ [N]
NH15AN	M4x0.7x6	14 200	LH15AN	M4x0.7x6	10 800	SH15AN	M4x0.7x6	10 100
NH15BN	M4x0.7x6	18 100	LH15BN	M4x0.7x6	14 600	SH15BN	M4x0.7x6	13 400
NH15EM	M5x0.8x7 <4.4>	14 200	LH15EM	M5x0.8x8	10 800	SH15EM	M5x0.8x8	10 100
NH15GM	M5x0.8x7 <4.4>	18 100	LH15GM	M5x0.8x7 <4.4>	14 600	SH15GM	M5x0.8x7 <4.4>	13 400
NH20AN	M5x0.8x6	23 700	LH20AN	M5x0.8x6	17 400	SH20AN	M5x0.8x6	16 300
NH20BN	M5x0.8x6	30 000	LH20BN	M5x0.8x6	23 500	SH20BN	M5x0.8x6	21 600
NH20EM	M6x1x9.5 <5.3>	23 700	LH20EM	M6x1x9.5 <5.3>	17 400	SH20EM	M6x1x9.5 <5.3>	16 300
NH20GM	M6x1x9.5 <5.3>	30 000	LH20GM	M6x1x9.5 <5.3>	23 500	SH20GM	M6x1x9.5 <5.3>	21 600
NH25AL	M6x1x6	33 500	LH25AL	M6x1x6	25 600	SH25AL	M6x1x6	22 400
NH25AN	M6x1x9	33 500	LH25AN	M6x1x9	25 600	SH25AN	M6x1x9	22 400
NH25BL	M6x1x6	45 500	LH25BL	M6x1x6	34 500	SH25BL	M6x1x6	32 000
NH25BN	M6x1x9	45 500	LH25BN	M6x1x9	34 500	SH25BN	M6x1x9	32 000
NH25EM	M8x1.25x10(11.5) <6.8>	33 500	LH25EM	M8x1.25x10(11.5) <6.8>	25 600	SH25EM	M8x1.25x10(11.5) <6.8>	22 400
NH25GM	M8x1.25x10(11.5) <6.8>	45 500	LH25GM	M8x1.25x10(11.5) <6.8>	34 500	SH25GM	M8x1.25x10(11.5) <6.8>	32 000
NH30AL	M8x1.25x8	41 000	LH30AL	M8x1.25x8	31 000	SH30AL	M8x1.25x8	31 000
NH30AN	M8x1.25x10	41 000	LH30AN	M8x1.25x10	31 000	SH30AN	M8x1.25x10	31 000
NH30BL	M8x1.25x8	61 000	LH30BL	M8x1.25x8	46 000	SH30BL	M8x1.25x8	46 000
NH30BN	M8x1.25x10	61 000	LH30BN	M8x1.25x10	46 000	SH30BN	M8x1.25x10	46 000
NH30EM	M10x1.5x12(14.5) <8.6>	47 000	LH30EM	M10x1.5x12(14.5) <8.6>	35 500	SH30EM	M10x1.5x12(14.5) <8.6>	35 500
NH30GM	M10x1.5x12(14.5) <8.6>	61 000	LH30GM	M10x1.5x12(14.5) <8.6>	46 000	SH30GM	M10x1.5x12(14.5) <8.6>	46 000
NH35AL	M8x1.25x8	62 500	LH35AL	M8x1.25x8	47 500	SH35AL	M8x1.25x8	47 500
NH35AN	M8x1.25x12	62 500	LH35AN	M8x1.25x12	47 500	SH35AN	M8x1.25x12	47 500
NH35BL	M8x1.25x8	81 000	LH35BL	M8x1.25x8	61 500	SH35BL	M8x1.25x8	61 500
NH35BN	M8x1.25x12	81 000	LH35BN	M8x1.25x12	61 500	SH35BN	M8x1.25x12	61 500
NH35EM	M10x1.5x13 <8.6>	62 500	LH35EM	M10x1.5x13 <8.6>	47 500	SH35EM	M10x1.5x13 <8.6>	47 500
NH35GM	M10x1.5x13 <8.6>	81 000	LH35GM	M10x1.5x13 <8.6>	61 500	SH35GM	M10x1.5x13 <8.6>	61 500
NH45AL	M10x1.5x10	107 000	LH45AL	M10x1.5x10	81 000	SH45AL	M10x1.5x10	76 500
NH45AN	M10x1.5x17	107 000	LH45AN	M10x1.5x17	81 000	SH45AN	M10x1.5x17	76 500
NH45BL	M10x1.5x10	131 000	LH45BL	M10x1.5x10	99 000	SH45BL	M10x1.5x10	94 500
NH45BN	M10x1.5x17	131 000	LH45BN	M10x1.5x17	99 000	SH45BN	M10x1.5x17	94 500
NH45EM	M12x1.75x15 <10.5>	107 000	LH45EM	M12x1.75x15 <10.5>	81 000	SH45EM	M12x1.75x15 <10.5>	76 500
NH45GM	M12x1.75x15 <10.5>	131 000	LH45GM	M12x1.75x15 <10.5>	99 000	SH45GM	M12x1.75x15 <10.5>	94 500
NH55AL	M12x1.75x13	158 000	LH55AL	M12x1.75x13	119 000	SH55AL	M12x1.75x13	113 000
NH55AN	M12x1.75x18	158 000	LH55AN	M12x1.75x18	119 000	SH55AN	M12x1.75x18	113 000
NH55BL	M12x1.75x13	193 000	LH55BL	M12x1.75x13	146 000	SH55BL	M12x1.75x13	140 000
NH55BN	M12x1.75x18	193 000	LH55BN	M12x1.75x18	146 000	SH55BN	M12x1.75x18	140 000
NH55EM	M14x2x18 <12.5>	158 000	LH55EM	M14x2x18 <12.5>	119 000	SH55EM	M14x2x18 <12.5>	113 000
NH55GM	M14x2x18 <12.5>	193 000	LH55GM	M14x2x18 <12.5>	146 000	SH55GM	M14x2x18 <12.5>	140 000
NH65AN	M16x2x20	239 000	LH65AN	M16x2x20	181 000	SH65AN	M16x2x20	173 000
NH65BN	M16x2x20	310 000	LH65BN	M16x2x20	235 000	SH65BN	M16x2x20	227 000
NH65EM	M16x2x24 <14.6>	239 000	LH65EM	M16x2x24 <14.6>	181 000	SH65EM	M16x2x24 <14.6>	173 000
NH65GM	M16x2x24 <14.6>	310 000	LH65GM	M16x2x24 <14.6>	235 000	SH65GM	M16x2x24 <14.6>	227 000

Notes: 1) Parenthesized dimensions are for items made of stainless steel.
2) Basic dynamic load rating is a load that allows for a 50-km rating fatigue life and is a vertical and constant load on the ball slide mounting surface.

New Series				Former series				
Model No.	Ball slide mounting hole dimension Mxpitchxℓ <Q> [mm]	Dynamic load rating C ₀ [N]	Model No.	Ball slide mounting hole dimension Mxpitchxℓ <Q> Q,ℓ [mm]	Dynamic load rating C ₀ [N]	Model No.	Ball slide mounting hole dimension Mxpitchxℓ <Q> Q,ℓ [mm]	Dynamic load rating C ₀ [N]
NS15CL	M4x0.7x6	7 250	LS15CL	M4x0.7x6	5 400	SS15CL	M4x0.7x6	4 900
NS15AL	M4x0.7x6	11 200	LS15AL	M4x0.7x6	8 350	SS15AL	M4x0.7x6	7 900
NS15JM	M5x0.8x7 <4.4>	7 250	LS15JM	M5x0.8x7 <4.4>	5 400	SS15JM	M5x0.8x7 <4.4>	4 900
NS15EM	M5x0.8x7 <4.4>	11 200	LS15EM	M5x0.8x7 <4.4>	8 350	SS15EM	M5x0.8x7 <4.4>	7 900
NS20CL	M5x0.8x7	10 600	LS20CL	M5x0.8x7	7 900	SS20CL	M5x0.8x7	7 250
NS20AL	M5x0.8x7	15 600	LS20AL	M5x0.8x7	11 700	SS20AL	M5x0.8x7	11 100
NS20JM	M6x1x9(9.5) <5.3>	10 600	LS20JM	M6x1x9(9.5) <5.3>	7 900	SS20JM	M6x1x9(9.5) <5.3>	7 250
NS20EM	M6x1x9(9.5) <5.3>	15 600	LS20EM	M6x1x9(9.5) <5.3>	11 700	SS20EM	M6x1x9(9.5) <5.3>	11 100
NS25CL	M6x1x9	17 700	LS25CL	M6x1x9	12 700	SS25CL	M6x1x9	12 700
NS25AL	M6x1x9	26 100	LS25AL	M6x1x9	18 800	SS25AL	M6x1x9	17 900
NS25JM	M8x1.25x10(11.5) <6.8>	17 700	LS25JM	M8x1.25x10(11.5) <6.8>	12 700	SS25JM	M8x1.25x10(11.5) <6.8>	12 700
NS25EM	M8x1.25x10(11.5) <6.8>	26 100	LS25EM	M8x1.25x10(11.5) <6.8>	18 800	SS25EM	M8x1.25x10(11.5) <6.8>	17 900
NS30CL	M8x1.25x12	24 700	LS30CL	M8x1.25x12	18 700	SS30CL	M8x1.25x12	18 700
NS30AL	M8x1.25x12	38 000	LS30AL	M8x1.25x12	28 800	SS30AL	M8x1.25x12	27 300
NS30JM	M10x1.5x12(14.5) <8.6>	24 700	LS30JM	M10x1.5x12(14.5) <8.6>	18 700	SS30JM	M10x1.5x12(14.5) <8.6>	18 700
NS30EM	M10x1.5x12(14.5) <8.6>	38 000	LS30EM	M10x1.5x12(14.5) <8.6>	28 800	SS30EM	M10x1.5x12(14.5) <8.6>	27 300
NS35CL	M8x1.25x12	34 500	LS35CL	M8x1.25x12	26 000	SS35CL	M8x1.25x12	26 000
NS35AL	M8x1.25x12	52 500	LS35AL	M8x1.25x12	40 000	SS35AL	M8x1.25x12	38 000
NS35JM	M10x1.5x13(14.5) <8.6>	34 500	LS35JM	M10x1.5x13(14.5) <8.6>	26 000	SS35JM	M10x1.5x13(14.5) <8.6>	26 000
NS35EM	M10x1.5x13(14.5) <8.6>	52 500	LS35EM	M10x1.5x13(14.5) <8.6>	40 000	SS35EM	M10x1.5x13(14.5) <8.6>	38 000

Notes: 1) Parenthesized dimensions are for items made of stainless steel.
2) Basic dynamic load rating is a load that allows for a 50-km rating fatigue life and is a vertical and constant load on the ball slide mounting surface.

In VH series, the slide types in flange shape are focused.

After focused			Before focused		
Model No.	Ball slide mounting hole dimension Mxpitchxℓ <Q> [mm]	Dynamic load rating C ₀ [N]	Model No.	Ball slide mounting hole dimension Mxpitchxℓ <Q> [mm]	Dynamic load rating C ₀ [N]
VH15EM	M5x0.8x7 <4.4>	14 200	VH15EL	M5x0.8x8	10 800
VH15GM	M5x0.8x7 <4.4>	18 100	VH15GL	M5x0.8x8	14 600
VH20EM	M6x1x9.5 <5.3>	23 700	VH20EL	M6x1x10	17 400
VH20GM	M6x1x9.5 <5.3>	30 000	VH20GL	M6x1x10	23 500
VH25EM	M8x1.25x10(11.5) <6.8>	33 500	VH25EL	M8x1.25x16(12)	25 600
VH25GM	M8x1.25x10(11.5) <6.8>	45 500	VH25GL	M8x1.25x16(12)	34 500
VH30EM	M10x1.5x12(14.5) <8.6>	47 000	VH30EL	M10x1.5x18(15)	35 500
VH30GM	M10x1.5x12(14.5) <8.6>	61 000	VH30GL	M10x1.5x18(15)	46 000
VH35EM	M10x1.5x13 <8.6>	62 500	VH35EL	M10x1.5x20(15)	47 500
VH35GM	M10x1.5x13 <8.6>	81 000	VH35GL	M10x1.5x20(15)	61 500
VH45EM	M12x1.75x15 <10.5>	107 000	VH45EL	M12x1.75x24	81 000
VH45GM	M12x1.75x15 <10.5>	131 000	VH45GL	M12x1.75x24	99 000
VH55EM	M14x2x18 <12.5>	158 000	VH55EL	M14x2x28	119 000
VH55GM	M14x2x18 <12.5>	193 000	VH55GL	M14x2x28	146 000

Notes: 1) Parenthesized dimensions are for items made of stainless steel.
2) Basic dynamic load rating is a load that allows for a 50-km rating fatigue life and is a vertical and constant load on the ball slide mounting surface.

A-6 Other Linear Rolling Guide Products

A-6-1 Linear Rolling Bushing

1. Features

(1) Low friction

Low friction owes to its design: Balls come into point contacts with raceway surface: the balls smoothly re-circulate. There is very little stick slip.

(2) Low noise

Noise level is low due to the ball retainer which is made of a synthetic resin.

(3) High precision

Due to NSK's superb quality control, precision is guaranteed.

(4) Dust prevention

Series with seal is available. The seal has small friction, and is highly durable. Highly dust-preventive double-lip system has been adopted.

(5) Superb durability

The material of outer sleeve is vacuum degassed, highly pure, and is heat-treated with good expertise.

(2) Adjustable clearance type LB-T (Fig. 2)

A part of the outer sleeve is cut open toward the axial direction. Used with a housing which can adjust inside diameter, it makes minute adjustment of the clearance between the linear shaft and the inscribed circle (an imaginary circle that connects the summit of the ball) of linear rolling bushing.



Fig. 2 Adjustable Clearance type LB-T

2. Models

There are two models

(1) Standard type LB (Fig. 1)

This model is the most commonly used, and is the only model that comes with a seal and in super precision grade.



Fig. 1 Standard type LB

3. Accuracy

(1) Accuracy grades

- Standard type LB.....High precision grade S, and super precision grade SP are available.
- Space adjustment type LB-T.....High precision grade S is available.

(2) Tolerance of rolling linear bushing, linear shaft and housing

Table 1 Tolerance for inscribed circle of the linear rolling bushing and shaft diameter Unit: μm

Nominal dimension/ inscribed circle diameter /shaft diameter (mm)		Tolerance/inscribed circle diameter ¹⁾				Tolerance/width B		Tolerance/slot distance of retaining rings Bn		Recommended tolerance/ shaft diameter			
		High precision grade S		Super high precision grade SP		High precision grade S Super high precision grade SP		High precision grade S Super high precision grade SP		High precision grade S		Super high precision grade SP	
over	or less	upper	lower	upper	lower	upper	lower	upper	lower	upper	lower	upper	lower
2.5	6												
6	10	0	-8	0	-5					-6	-14	-4	-9
10	18					0	-120	+240	-240	-6	-15	-4	-10
18	30	0	-10	0	-6					-6	-17	-4	-12
30	50	0	-12	0	-8					-6	-19	-4	-13
										-7	-23	-5	-16

Table 2 Tolerance of linear rolling bush outside diameter, and housing inside diameter Unit: μm

Nominal dimension/ outside diameter/housing inside diameter (mm)		Tolerance/outside diameter D ¹⁾				Eccentricity ²⁾	Tolerance/housing inside diameter			
		High precision grade S		Super high precision grade SP			High precision grade S		Super high precision grade SP	
over	or less	upper	lower	upper	lower	Maximum	upper	lower	upper	lower
2.5	6						+12	0	+8	0
6	10	0	-10	0	-7	8	+15	0	+9	0
10	18						+18	0	+11	0
18	30	0	-12	0	-8	9	+21	0	+13	0
30	50	0	-14	0	-9	10	+25	0	+16	0

*1) For adjustable clearance type, figures indicate tolerances before the cut is made.

*2) Eccentricity means the run-out of offset between the centers of outer sleeve diameter and inscribed circle diameter.

4. Composition of Reference Number

Example	LB	35	N	K	Y	S
Linear rolling bushing						
Nominal inscribed circle diameter (linear shaft nominal diameter)						
N.....With retaining ring groove No code.....Without retaining ring groove						
No code.....Standard type LB T.....Adjustable clearance type LB-T						
						Accuracy grade S.....High precision grade SP.....Super precision grade No code.....No seal D.....Single-side seal DD.....Double-side seal
						Plastic retainer

5. Lubrication and Friction

(1) Grease lubrication

① Supply at initial stage

At time of delivery, the linear rolling bushing has a coat of rust preventive agent. Wipe it off with clean kerosene or organic solvent. Dry with an air blower, etc., then apply grease. Lithium soap based greases with consistency level of 2 are generally used (e.g. NSK Grease LR3, PS2, and AS2).

② Replenishment

- Sealed linear rolling bushing is designed to be a disposal item. Therefore, a replenishing grease is considered to be not required. However, if replenishment becomes necessary due to dirty environment or wear of the seal, remove the linear bushing from the shaft and replenish lubricant in the same manner as the initial lubricating.
- For items without seal, wipe off old grease from the linear shaft, and apply new grease.
- Intervals of replenishments are every 100 km in a dirty environment, 500 km in a slightly dirty environment, 1 000 km or no replenishing for a normal environment.

(2) Oil lubrication

It is not necessary to wash off the rust preventive agent applied before delivery. Use an oil of ISO viscosity grade VG15-100. Drip the oil on the linear shaft by an oil supply system.

Temperature to use

- 30°C to 50°C Viscosity VG15 - 46
- 50°C to 80°C Viscosity VG46 - 100

Lubricant is removed by the seal if the linear ball bearing has a seal. Therefore, the drip method cannot be used except for single-seal types.

(3) Friction coefficient

The linear rolling bushing has a small dynamic friction coefficient. This contributes to low power loss and temperature rise.

According to Fig. 3, dynamic friction coefficient is merely 0.001-0.004. Also, at the speed of under 60 m/min, there is no danger of the temperature rising. Friction force can be obtained by the following formula.

$$F = \mu \cdot P \dots \dots \dots (1)$$

In this formula:

- F : Friction force (N)
- P : Load (vertical load to the shaft center line) (N)
- μ : Friction coefficient (dynamic or static)

For a seal type, a seal resistance of 0.3 to 2.40 N is added to the above.

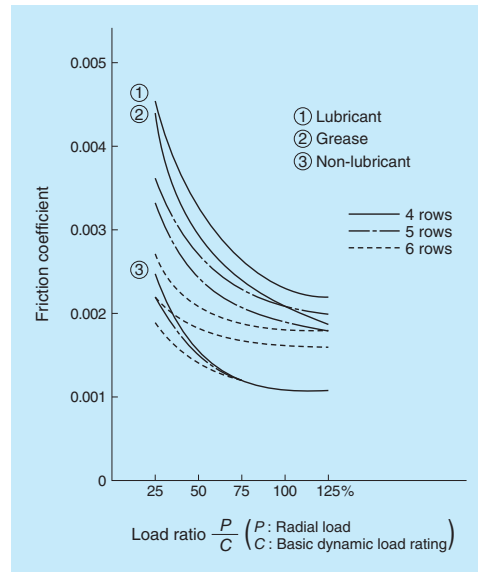

Fig. 3 Dynamic friction coefficient of linear rolling bushing

6. Range of Conditions to Use

Generally, use under the following conditions.

Please consult NSK when values exceed the ranges given below.

Temperature: - 30°C to 80°C

Speed: Up to 120 m/min

(excluding oscillation and short strokes)

7. Preload and Rigidity

The linear rolling bushing is normally used without applying preload. If high positioning accuracy is required, set the clearance between the linear rolling bush and the shaft at the range of 0 to 5 μ m. Slight preload is a general rule (1% of basic dynamic load rating C -- see the dimension table).

The dimension table shows theoretical rigidity *K* when clearance with the shaft is zero, and a load of 0.1 C is applied to the summit of the ball.

Rigidity *K_N*, when load is not 0.1C, is obtained by the following formula.

$$K_N = K (P/0.1C)^{1/3} \dots \dots \dots (2)$$

In this formula:

- K : Rigidity value in the dimension table (N/ μ m)
- P : Radial load (N)

When the load is applied between the ball rows, the load becomes 1.122 times for 4 ball rows; 0.959 times for 5 ball rows; 0.98 times for 6 ball rows.

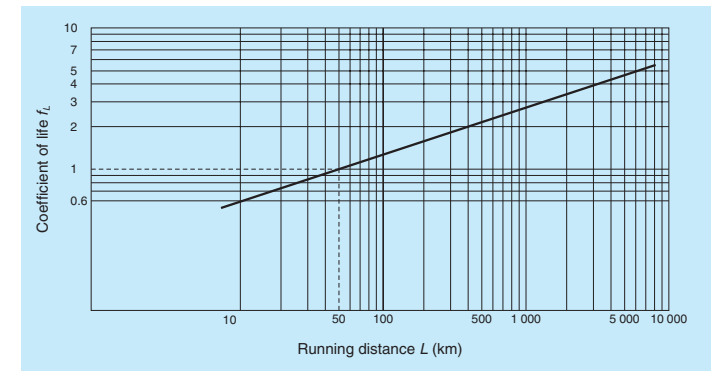

Fig. 4 Relationship between life factor and running distance

8. Basic Load Rating and Rated Life

(1) Basic dynamic load rating

Basic dynamic load rating C is: A radial load which allows 90% of a group of linear rolling bush to run a distance of 50 km without suffering damage when they are moved individually.

There is a relationship as below between C and the life

$$L = 50 f_L^3 \dots \dots \dots (3)$$

$$f_L = C/P \dots \dots \dots (4)$$

In this formula:

- L : Rated life (km)
- P : Radial load (N)
- f_L : Life factor (Refer to Fig. 4)

This formula is used provided that the shaft hardness is HRC58 or higher. Rated life is shorter if the shaft is softer. In this case, find the hardness factor *f_H* from Fig. 5, and multiply the value.

$$f_L = C \cdot f_H/P \dots \dots \dots (5)$$

Or

$$C = P \cdot f_L/f_H \dots \dots \dots (6)$$

Life in time can be obtained by the following formula, substituting for given stroke length, cycle numbers, and running distance:

$$L_h = (L/1.2 \cdot S \cdot n) \times 10^4 \dots \dots \dots (7)$$

In this formula:

- L_h : Life hours (h)
- L : Rated life (km)
- S : Stroke (mm)
- n : Cycles per minute (cpm)

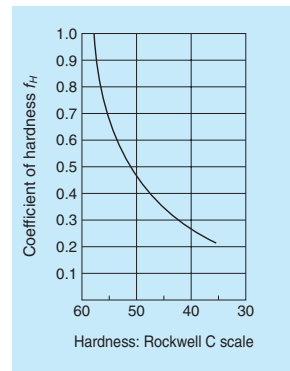

Fig. 5 Hardness factor

(2) Basic static load rating

It is a load that the total permanent deformation of outer sleeve, ball and shaft at the contact point, becomes 0.01% of the ball diameter when this load is applied to the rolling bushing. It is understood in general that this is the applicable load limit which causes this much permanent deformation without hampering operation.

(3) Calculation example

What is the appropriate rolling bushing size if required life is 5 000 hours?

Conditions are:

- Three linear rolling bushings are installed in two parallel shafts, and support a reciprocating table.
- Load 450 N is equally distributed to the three bushings.
- The table is required to reciprocate on the shafts at 200 times per minute at a stroke of 70 mm.
- Hardness of the shaft: HRC 55

$$450/3 = 150 \text{ (N)}$$

• Load per linear rolling bushing is:

From Formula (7), the required life when indicated in distance is:

$$L = 5 \times 10^3 \times 1.2 \times 70 \times 200/10^4 = 8.4 \times 10^3 \text{ (km)}$$

From Fig. 4 and Fig. 5,

Life factor $f_L = 5.6$

Hardness factor $f_H = 0.65$

Therefore, from Formula (6),

$$C = P \times f_L / f_H = 150 \times 5.6 / 0.65 = 1\,292 \text{ (N)}$$

Based on the above, select linear rolling bushing LB30NY with shaft diameter of 30 mm, basic dynamic load rating of 1 400 N.

(4) Compensating load rating by ball row position

Load rating of the linear rolling bushing changes by the position of the ball circuit rows.

Permissible load is larger when it is applied to the middle of the ball circuit rows than when it is applied directly above the ball row (Fig. 6).

(Radial clearance set at zero in this case.)

Load ratings in the dimension table are in case "A" when it is applied directly above the ball circuit row. If used as in case "B," the load rating becomes larger (refer to Fig. 6).

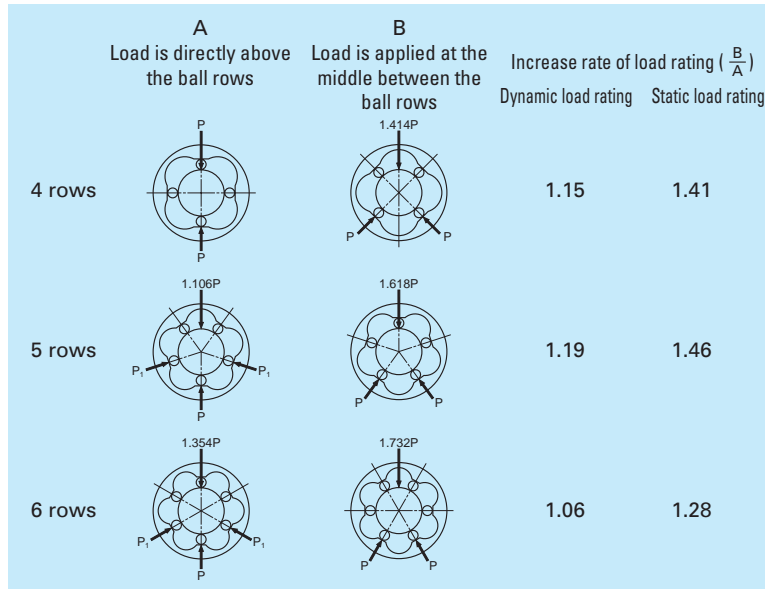

Fig. 6 Increasing rate of load rating by position of ball row (B/A)

9. Shaft Specification

Harden the shaft surface where the balls run with heat treatment to provide the following values.

- Surface hardness: HRC58 or over
- Depth of core hardness at HRC50 or higher
 - Depth for LB3; 0.3 mm or deeper
 - Depth for LB50; 1.2 mm or deeper

Roughness of the surface should be:

- For SP grade, and "the clearance for fit" with the ball bushing less than $5 \mu\text{m}$ - Less than 0.8 S
- For SP grade with "the clearance" of more than $5 \mu\text{m}$, and for S grade - Less than 1.2 S

Bending should be:

- LB3 -- $15 \mu\text{m}/100 \text{ mm}$
- LB50 -- $100 \mu\text{m}/1\,000 \text{ mm}$

An appropriate clearance for normal use conditions can be obtained when the tolerance in shaft diameter remains within the recommended range (refer to Table 1 on page A322). For operations which require particular accuracy, select the shaft diameter which creates a clearance in the range of 0 to 0.005 (mm) for example, when assembled with the rolling bushing.

10. Dust Proof

Select a linear rolling bushing with seals to prevent moisture or foreign matters which are floating in the air from entering.

11. Installation

(1) Combination of shaft and linear rolling bushing

When the linear rolling bushing is installed in a linear motion table for its reciprocating movement, it is necessary to prevent the table from rotating. In general, for this reason, two shafts installed with two linear rolling bushings on each are used.

Fig. 7 is an installation example.

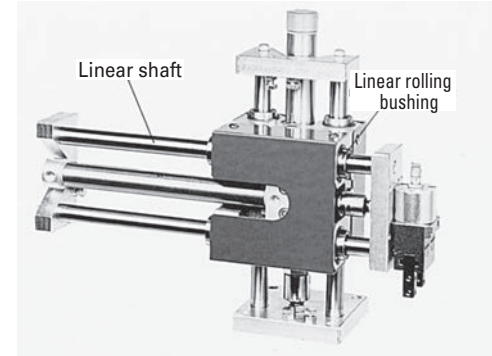

Fig. 7 Installation example

(2) Installation of linear rolling bushing

1) Standard type installation

Fig. 8 shows a method using a retainer ring. Linear rolling bushing can also be secured to the housing using a stop plate and/or screw.

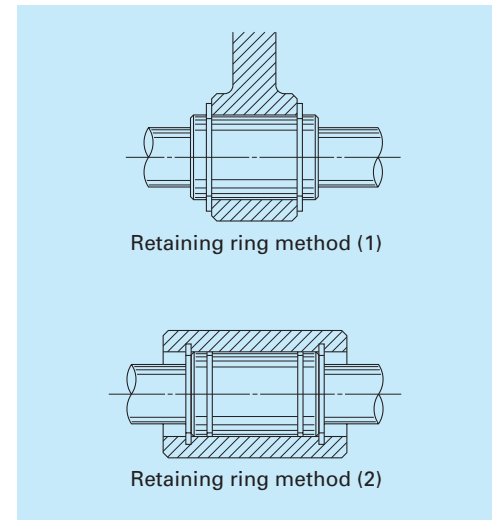

Fig. 8 Installation using retaining rings

- a) Housing inside diameter should be of a recommended value (Table 2, page A322). The entire rolling bushing contracts and gives excessive preload if: the inside diameter is small; the roundness or cylindricity is excessive. This may result in an unexpected failure.
- b) To install linear rolling bushing, use a tool (Fig. 9) and squeeze it in, or use a holder and lightly pound it.

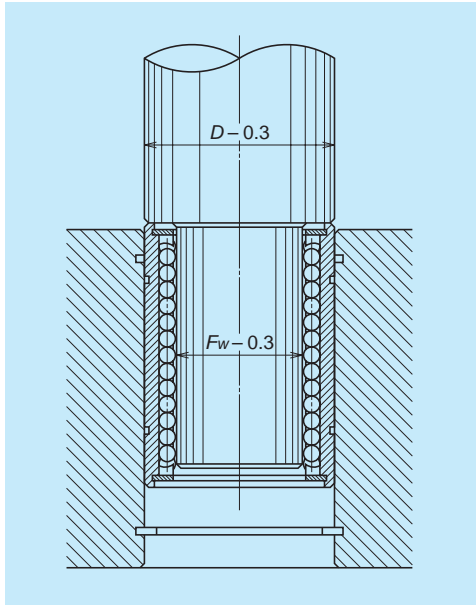

Fig. 9 Tool to install a linear rolling bushing

(3) Precaution for installing a shaft in the linear rolling bushing

- 1) To install two shafts parallel to each other, first install one shaft accurately. Use this as a reference, and install the other parallel to the first shaft. This makes installation easy.
- 2) Do not incline the shaft when inserting it into the linear rolling bushing. Do not force it to enter by twisting. This deforms the retainer, and causes the balls to fall out.
- 3) Do not use the shaft for rotating movement after inserting the shaft to the linear rolling bushing. The balls slip and damage the shaft.
- 4) Do not twist the shaft after it is inserted to the linear rolling bushing. The pressure scars the shaft.

12. Dimension tables

Model LB (standard type), no seal

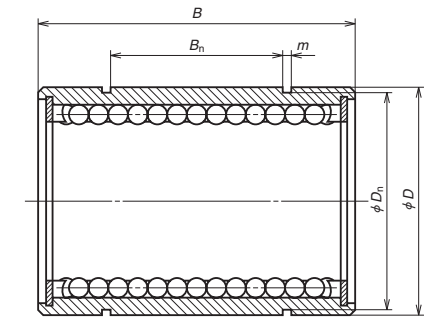
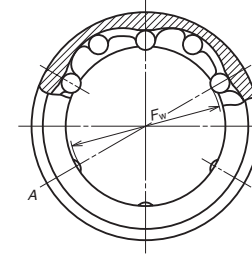

Section A-A

Unit: mm

Model No.	Inscribed circle diameter F_w	Outside diameter D	Length B	Retaining ring groove			Stiffness ^{*1} (N/ μ m)	Number of ball circuit	Weight (kg) (Reference only)	Basic dynamic load rating C (N)	Basic static load rating C_0 (N)
				Distance B_n	Width m	Bottom diameter D_n					
LB3Y	3	7	10	—	—	—	3	4	0.0016	20	39
LB4Y	4	8	12	—	—	—	4.5	4	0.0022	29	59
LB6NY	6	12	19	11	1.15	11.5	7	4	0.0074	74	147
LB8ANY ^{*2}	8	15	17	9	1.15	14.3	5.5	4	0.0094	78	118
LB8NY	8	15	24	15	1.15	14.3	9.5	4	0.014	118	226
LB10NY	10	19	29	19	1.35	18	12	4	0.025	206	355
LB12NY	12	21	30	20	1.35	20	13	4	0.028	265	500
LB13NY	13	23	32	20	1.35	22	13	4	0.040	294	510
LB16NY	16	28	37	23	1.65	26.6	14	4	0.063	440	635
LB20NY	20	32	42	27	1.65	30.3	19	5	0.088	610	1 010
LB25NY	25	40	59	37	1.9	38	35	6	0.267	1 000	1 960
LB30NY	30	45	64	40	1.9	42.5	41	6	0.305	1 400	2 500
LB35NY	35	52	70	45	2.2	49	48	6	0.440	1 510	2 800
LB40NY	40	60	80	56	2.2	57	54	6	0.520	2 230	4 000
LB50NY	50	80	100	68	2.7	76.5	69	6	1.770	4 100	7 100

*1): Refer to Section (7).

*2): Semi-standard item of which length B is shorter than standard.

2) Installation of adjustable clearance type

Use a housing which can adjust the inside diameter of the rolling bushing. This way, the clearance between the rolling bushing and the linear shaft can be easily adjusted. Arrange the cut-open section of the rolling bushing at a 90-degree angle to the housing's cut-open section. This is the most effective way to evenly distribute deformation toward circumferential direction.

The tolerance of shaft diameter of the adjustable clearance type should be within the recommended range (refer to **Table 1** on page A322). As a general rule, set the preload at slight or light volume. (Do not provide excessive preload.) Use a dial gauge to measure and adjust clearance. However, here is an easy method to adjust.

First, loosen the housing until shaft turns freely. Then narrow the clearance gradually. Stop at the point when the shaft rotation becomes heavy. This creates a clearance zero or light preload.

Model LB (standard type), with seal

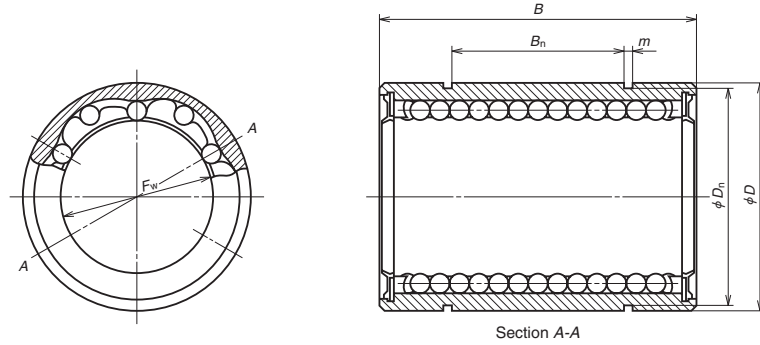

Model LB-T (Adjustable clearance type)

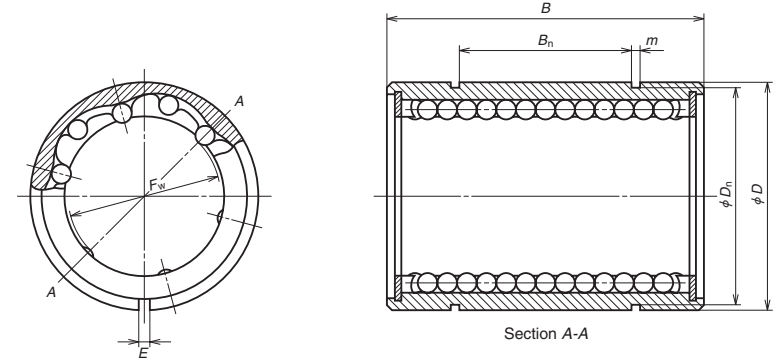

Unit: mm

*Model No.	Inscribed circle diameter F_w	Outside diameter D	Length B	Retaining ring groove			Number of ball circuit	Weight (kg) (Reference only)	Basic dynamic load rating C (N)	Basic static load rating C_0 (N)
				Distance B_n	Width m	Bottom diameter D_n				
LB6NYDD	6	12	19	11	1.15	11.5	4	0.0074	74	147
LB8ANYDD	8	15	17	9	1.15	14.3	4	0.0094	78	118
LB8NYDD	8	15	24	15	1.15	14.3	4	0.014	118	226
LB10NYDD	10	19	29	19	1.35	18	4	0.025	206	355
LB12NYDD	12	21	30	20	1.35	20	4	0.028	265	500
LB13NYDD	13	23	32	20	1.35	22	4	0.040	294	510
LB16NYDD	16	28	37	23	1.65	26.6	4	0.063	440	635
LB20NYDD	20	32	42	27	1.65	30.3	5	0.088	610	1 010
LB25NYDD	25	40	59	37	1.9	38	6	0.267	1 000	1 960
LB30NYDD	30	45	64	40	1.9	42.5	6	0.305	1 400	2 500
LB35NYDD	35	52	70	45	2.2	49	6	0.440	1 510	2 800
LB40NYDD	40	60	80	56	2.2	57	6	0.520	2 230	4 000
LB50NYDD	50	80	100	68	2.7	76.5	6	1.770	4 100	7 100

Unit: mm

Model No.	Inscribed circle diameter F_w	Outside diameter D	Length B	Opening width E	Retaining ring groove			Number of ball circuit	Weight (kg) (Reference only)	Basic dynamic load rating C (N)	Basic static load rating C_0 (N)
					Distance B_n	Width m	Bottom diameter D_n				
LB6NTY	6	12	19	0.8	11	1.15	11.5	4	0.0073	74	147
LB8ANTY	8	15	17	1	9	1.15	14.3	4	0.0093	78	118
LB8NTY	8	15	24	1	15	1.15	14.3	4	0.014	118	226
LB10NTY	10	19	29	1.5	19	1.35	18	4	0.025	206	355
LB12NTY	12	21	30	1.5	20	1.35	20	4	0.028	265	500
LB13NTY	13	23	32	1.5	20	1.35	22	4	0.040	294	510
LB16NTY	16	28	37	1.5	23	1.65	26.6	4	0.062	440	635
LB20NTY	20	32	42	2	27	1.65	30.3	5	0.087	610	1 010
LB25NTY	25	40	59	2	37	1.9	38	6	0.265	1 000	1 960
LB30NTY	30	45	64	2	40	1.9	42.5	6	0.302	1 400	2 500
LB35NTY	35	52	70	3	45	2.2	49	6	0.44	1 510	2 800
LB40NTY	40	60	80	3	56	2.2	57	6	0.52	2 230	4 000
LB50NTY	50	80	100	3	68	2.7	76.5	6	1.75	4 100	7 100

*) Single-seal type is indicated as LB-D.

A-6-2 Roller Pack

1. Structure

A roller pack comprises a main body which supports load from the guide way block via two rows of rollers; an end cap which changes the direction of the re-circulation of rollers at the end of the main body; a side plate which guides the rollers (**Fig. 1**). Roller pack is one of the linear rolling guides, where rollers are allowed to re-circulate infinitely.

There is a plate spring attached to a side of roller pack to prevent roller pack from falling out when it is turned upside down after assembly.

Other component of the roller pack is spring pin. Spring pin is on the top surface of the roller pack, and makes installation of wedge block and fitting plate easier.

Wedge block is a unit to provide preload (**Fig. 3**) to roller pack; a fitting plate (**Fig. 2**), functioning like a pivot, adjusts misalignment of roller pack automatically. Wedge of wedge block moves up and down to apply preload by turning the adjust screw.



Photo 1 Roller pack

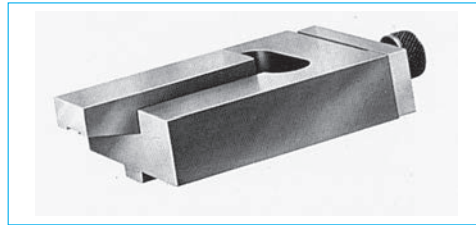

Photo 2 Wedge block

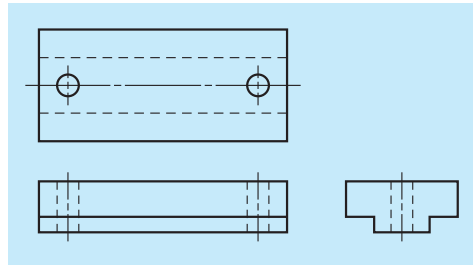

Fig. 2 Fitting plate

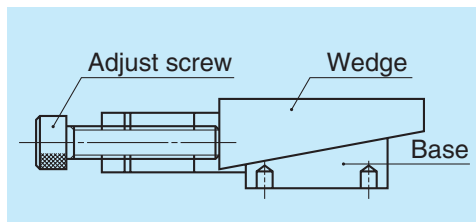

Fig. 3 Wedge block

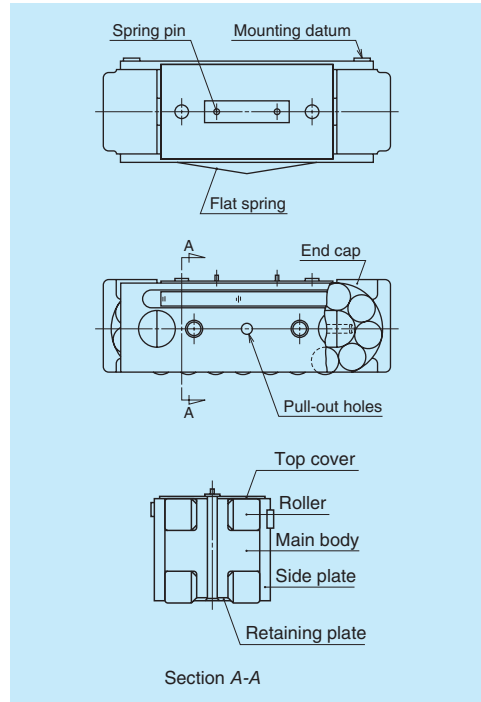

Fig. 1 Roller pack

2. Features

Roller pack has two remarkable characteristics other linear roller guide bearings do not have.

(1) No roller skewing

If the roller is long relative to its diameter, the roller inclines during operation. This phenomenon is called skewing. Skewing causes problems such as sudden rise in friction force. However, a short roller lacks large load carrying capacity. The roller introduced here solved the skewing problem, yet has a large load carrying capacity: short rollers are combined into double rows.

(2) Load is applied equally.

This is due to a "fitting plate," a result of "changed way of conceiving." Installation is quite easy: Merely place the fitting plate through the two holes to spring pins. The stop pins are inserted to holes on the top surface of the roller pack. The contact area between the fitting plate and the main body is made small. This way, the self-alignment is automatically accomplished by elastic contact of both parts.

This distributes an equal load to the rollers, far extending the life, compared to conventional roller linear guides.

Other characteristics include: Easy to provide preload by the wedge block; can be installed to vertical shaft; and reduction in noise level.

3. Accuracy

The height tolerance of roller pack is 10 μm . Roller packs are grouped into a size difference of every 2 μm (corded by A to E) before delivery (**Table 1**).

Table 1 Height Classification

		Unit: μm
Category		Code
over +3	or less +5	A
+1	- +3	B
-1	- +1	C
-3	- -1	D
-5	- -3	E

4. Rigidity

Fig. 4 shows the relationship between load and deformation. This includes deformation caused by contact between: the rollers and main body; the rollers and guide way surface; the main body and fitting plate.

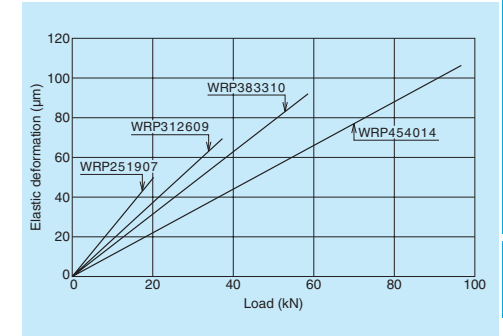

Fig. 4 Elastic deformation of the roller pack

5. Preload

Fig. 5 shows conversions of tightening torque of the wedge block adjust screw into preload volume. Use a dial gauge for accurate measurement.

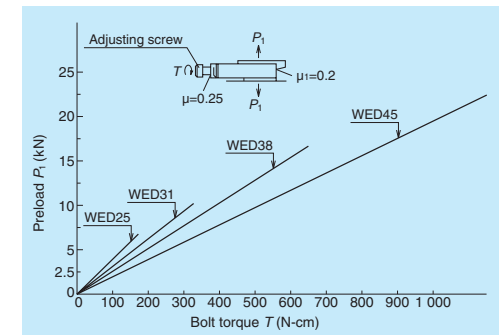

Fig. 5 Tightening torque of the adjust screw, and preload volume

6. Friction and Lubrication

(1) Lubricants and volume

Mineral oils are commonly used. Since roller pack is used under a relatively heavy load, the oil should, ideally, have high viscosity and provide a strong film. Select from JIS viscosity 32-150.

Criteria of oil supply per roller pack Q (cc/h) can be calculated by the following formula.

$$Q \geq S \times 1/4 \dots\dots\dots (1)$$

In this formula, S (stroke) is shown in meters. The oil volume, when the stroke is 1 m, per roller pack is more than 0.25 (cc/h). It is more desirable to supply a small amount of oil at short intervals than supplying a large amount at one time. In case of grease lubrication, use a grease of consistency 2. Albania EP2 is widely used.

(2) Friction coefficient

Starting friction coefficient is significantly small at under 0.005.

(3) Seal

It is necessary to install a wiper seal to the guide way surface to prevent foreign matters (swarf from cutting, and other dust) from entering the roller pack to enjoy the full benefit of the designed life of it. The material of the seal should have strong resistance to oil and wear. Felt and synthetic rubber (acrylonitril butadiene rubber) are some of the suitable materials. Fig. 6 shows a general method to install the seals.

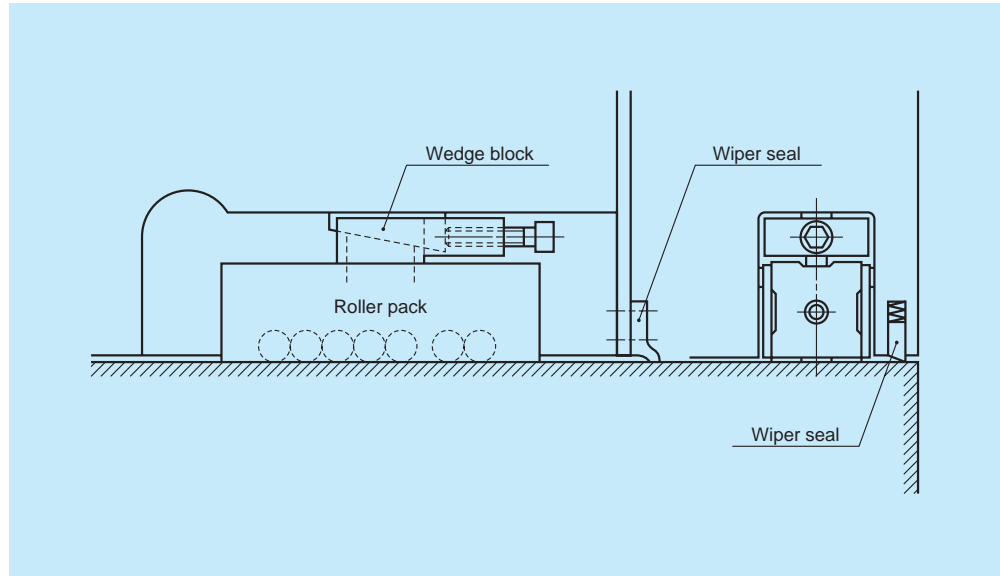

Fig. 6 Installation of seal

7. Installation

(1) Installation and applying preload

As shown in Fig. 7, it is basic that a fitting plate is installed on the roller pack which receives load, and a wedge block is installed on the roller pack which receives no load, but is only used for preload. All components should be secured with a stop pin, facing toward the direction of movement. To cut costs for processing, it is recommended to divide the pocket (which contains roller pack) into some blocks and secure them with bolts (Fig. 7). Preload is provided by the wedge block. Estimate the actual load beforehand, so the preload shall not be lost when a load is applied. A load variation equivalent to up to two times of the preload volume can be absorbed in this case.

(Take into consideration the rated life in 8. in determining preload volume.)

(2) Accuracy of way block

The following is the ideal accuracy specification and installation accuracy of way block as a guide surface.

- Hardness by heat treatment : More than HRC58 hardened depth 2 mm or more
- Surface roughness : Less than 1.6 S
- Parallelism as a single unit: Less than 0.010 mm per meter
- Parallelism after installation : Less than 0.020 mm per meter

Please consult NSK when using cast iron or cast steel guide face.

(3) Pocket accuracy

Accuracy of the pocket in which the roller pack is mounted should satisfy the following conditions.

- Pocket width : Roller pack width + 0.10 to 0.20 mm
- Parallelism of the pocket side faces to the guide way face : Less than 0.010 mm per 100 mm.
- Parallelism of the fitting plate (pocket bottom) mounting surface to the guide way face and parallelism of the wedge block mounting surface to the guide way surface : Less than 0.040 mm per 100 mm.

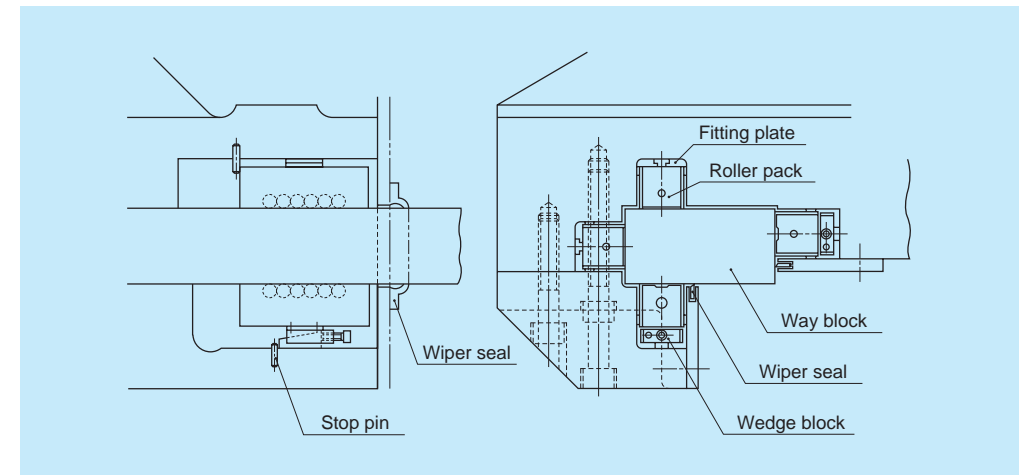

Fig. 7 Design of the roller pack pocket (example)

8. Rated life

Rated life L (km) is shown in the following formula.
In this formula:

$$L = 50 \left(\frac{C}{f_w \cdot F_c} \right)^{\frac{10}{3}} \dots\dots\dots (2)$$

- C: Basic dynamic load rating (N)
- f_w: Load factors. 1.0 to 1.2 at time of smooth operation
- F_c: Calculated load (N) applied to the roller pack

9. Disassembly

Remove the roller pack preloaded by the wedge block in the following manner.

- Loosen the adjust screw of the wedge block. Lightly tap the wedge. In case of light preload, the wedge loosens, and the roller pack can be pulled out.
- When pulling, put the bolt in the tap hole at the end of the end cap, and tug the bolt.
- In case of heavy load, the roller pack could not be pulled out by the above method. Hook a tool to the pull-out hole (Fig. 1) on the side plate of the roller pack, and pull out the roller pack.

10. Dimension Table

Roller pack: Model WRP

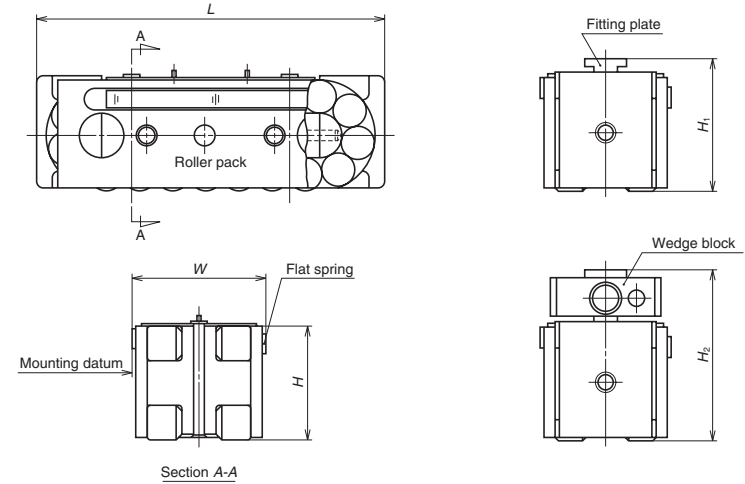

Unit: mm									
Model No.	Width W	Height ±0.005 H	Length L	Applicable fitting plate reference No.	Assembled height H ₁	Applicable wedge reference No.	Assembled height H ₂	Basic dynamic load rating C (N)	Basic static load rating C ₀ (N)
WRP 251907	25	19	65.5	WFT 25	24	WED 25	31 (30.4 – 31.6)	31 000	40 500
WRP 312609	31	26	85	WFT 31	31	WED 31	40 (39.4 – 40.6)	57 000	73 000
WRP 383310	38.1	33.31	104.4	WFT 38	38.91	WED 38	50.8 (50 – 51.5)	91 000	113 000
WRP 454014	45	40	138	WFT 45	45	WED 45	60 (59.2 – 60.8)	151 000	191 000

Note : Numbers in the parentheses in column H₂ show the adjustable height range of the wedge block.

A-6-3 Linear Roller Bearings

1. Structure

Linear roller bearing comprises: A single row of rollers; the main body which supports load via rollers; the end cap which turns the roller recirculating direction at the end of the main body from the loaded zone to the unloaded zone; a retaining wire which prevents rollers from falling out (Fig. 1). The main body, as the cylindrical roller bearing, has a rib at both sides. The rib guides the rollers to travel correctly, and assists the rollers to circulate infinitely in the bearing in a stable manner. This contributes to the bearing's linear movement without the restriction of travel range.

NSK also developed a highly functional preload pad

(Photo 2) to provide a slight preload to the bearing. The preload pad basically comprises parallel plates and sandwiched Belleville springs, having adjusted its spring rate.

Preloaded pad can be used in a machine tool in the following manner.

When two bearings are installed with one on the top and the other under the way block (the bearings comprise a set), a preloaded pad is used at the bottom bearing. This provides an equal preload to the top and bottom bearings. This way, to a certain extent, the variation in the load and the uneven thickness of the way block can be absorbed.

Fitting plate: Model WFT

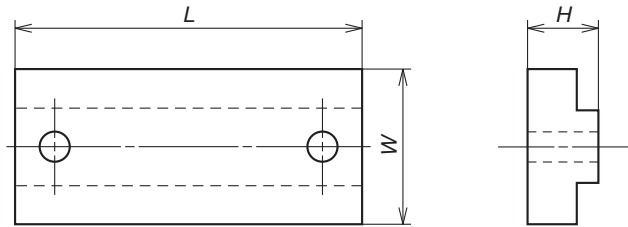

Unit: mm

Model No.	Width W	Height H (± 0.01)	Length L	Applicable roller pack
WFT 25	10	5	20	WRP 251907
WFT 31	12	5	26	WRP 312609
WFT 38	12.8	5.6	29	WRP 383310
WFT 45	16	5	40	WRP 454014

Wedge block: Model WED

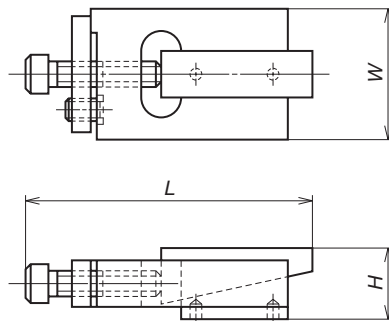

Unit: mm

Model No.	Width W	Height H	Length L	Applicable roller pack
WED 25	23	12 (11.5 – 12.5)	47	WRP 251907
WED 31	28	14 (13.5 – 14.5)	63	WRP 312609
WED 38	35	17.47 (16.9 – 18.1)	76	WRP 383310
WED 45	40	20 (19.2 – 20.8)	95	WRP 454014

Note : Numbers in the parentheses in column H_2 show adjustable height range of the wedge block.

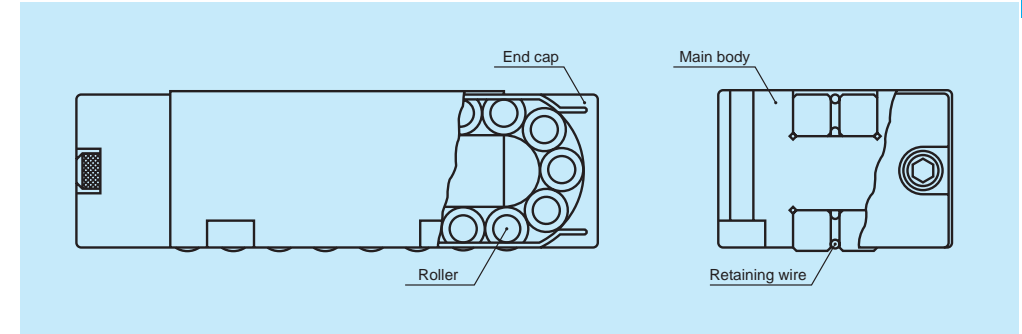

Fig. 1 Linear roller bearing



Photo 1 Linear roller bearing



Photo 2 Preload pad

2. Features

In addition to the general features of a roller bearing guide such as no-stick slip, small friction resistance, and easy maintenance, the linear roller bearing has several more advantages.

(1) No trouble by roller skewing

Skewing is the inclination of the rollers during operation. It causes friction force to suddenly soar. Skewing is apt to occur when the roller is long relative to its diameter. The proportion of the length and diameter is 1:2 for the products in this series. This is superior to the commonly used 1:3 ratio.

(2) Highly reliable

Retaining the rollers without allowing them to fall out of the bearing is a crucial function of the linear guide bearing. The simple and highly effective retaining wire has solved the problem for this product series.

(3) Compact design

Despite the load carrying capacity, this series is smaller in size than any other models. This contributes to the application which requires compact design.

(4) High rigidity

The contact area between the bearing and the mounting surface is large to increase rigidity.

3. Accuracy

The nominal height difference between bearings is 10 μm. The bearings are grouped into every 2 μm, and are coded before delivery (Table 1).

Table 1 Classification of height

Unit: μm

Category			Code
over	–	or less	
0	–	–2	A
–2	–	–4	B
–4	–	–6	C
–6	–	–8	D
–8	–	–10	E

4. Rigidity

Fig. 2 shows elastic deformation.

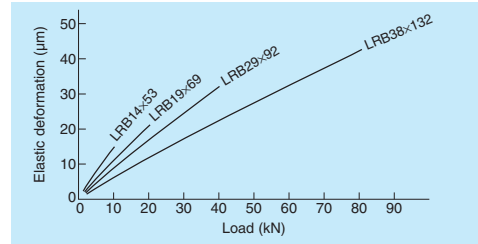

Fig. 2 Elastic deformation

5. Friction and Lubrication

(1) Lubricants and volume

Mineral oils are used in general. The linear roller bearing is used under relatively heavy load. An oil which has high viscosity and creates a strong oil film is ideal for linear roller guides. Select from JIS viscosity 32 to 150.

General oil supply for a linear roller bearing Q (cc/h) can be calculated by the following formula.

$$Q \geq S \times 1/4 \dots \dots \dots (1)$$

In this formula, S (stroke) is shown in meters. Therefore, when the stroke is 1 m, the volume of lubricant per roller bearing is more than 0.25 (cc/h). It is recommended to supply a small amount of oil at short intervals rather than supplying a large amount at one time. In case of grease lubrication, a grease of consistency degree 2, such as Albania EP2, is generally used.

(2) Friction coefficient

Starting friction coefficient is significantly small at under 0.005.

(3) Seal

Install a wiper seal on the way block surface to prevent foreign matters (cutting chip and other contaminant from entering) to realize a full life of the linear roller bearing. The material of the seal should have strong resistance against oil and wear. Felt and synthetic rubber (acrylonitril-butadien rubber) are some of the suitable materials.

6. Installation

Secure the linear roller bearing using four bolts. The bearing main body has four holes for mounting.

Accuracy of way block

The ideal accuracy specification and mounting accuracy of a way block as a guide way surface are as follows.

- Hardness by heat treatment : More than HRC58 hardened depth 2 mm or more
- Surface roughness : Less than 1.6 S
- Parallelism as a single unit : Less than 0.010 mm per 1 m
- Parallelism after installation : Less than 0.020 mm per 1 m

Please consult NSK when using cast iron or cast steel guide way.

7. Rated life

Rated life L (km) is shown in the following formula.

In this formula:

$$L = 50 \left(\frac{C}{f_w \cdot F_c} \right)^{10/3} \dots \dots \dots (2)$$

- C : Basic dynamic load rating (N)
- f_w : Load factor. 1.0 to 1.2 at time of smooth operation
- F_c : Calculated load applied on the bearing (N)

8. Dimension Table

Linear roller bearing Model: LRB

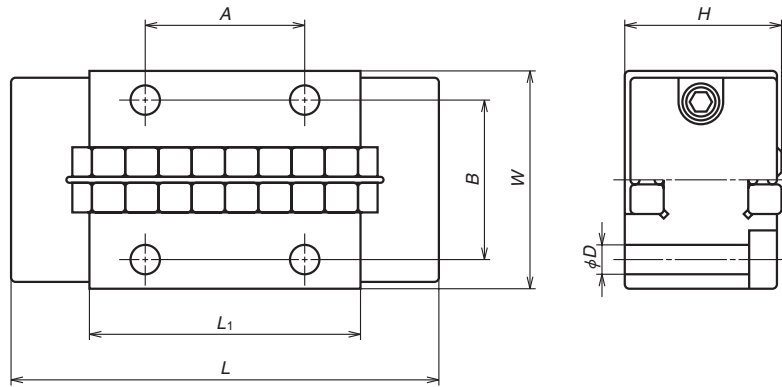

Preload pad Model: PRP

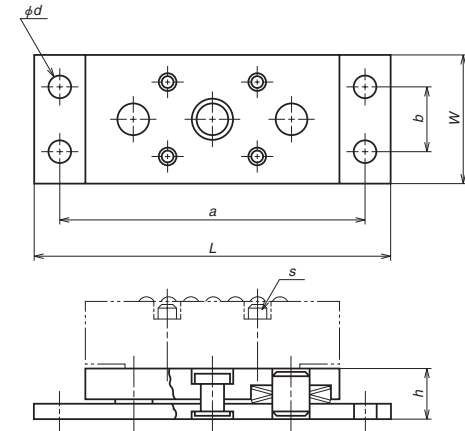

Unit: mm

Model No.	Width W	Height $H_{3.0/10}$	Length L	L_1	Roller diameter x length	Mounting bolt hole D	Bolt hole distance		Basic dynamic load rating C (N)	Basic static load rating C_0 (N)
							A	B		
LRB 14×53	26.5	14.29	52.8	32.8	ϕ 4×8	3.4	19	19.3	15 400	21 900
LRB 19×69	30.5	19.05	68.6	44.6	ϕ 5×10	3.4	25.4	23.3	27 000	39 000
LRB 29×92	41.5	28.58	92.0	59	ϕ 7.5×15	4.5	38.1	32.7	57 500	76 500
LRB 38×132	51.4	38.10	132.0	88	ϕ 10×20	5.5	50.8	41.5	119 000	159 000

Note: Bearings are grouped into heights of every 2 μ m before delivery.

Unit: mm

Model No.	Applicable linear roller bearing	Height (no-load) h max.	Compressed height h min.	h min. Load when fully compressed (N)	W	L	d	a	b	s Hex. Socket cap screw
PRP 14×53	LRB 14×53	10.23	9.53	1 570	26	72	4.5	62	14	M3×16
PRP 19×69	LRB 19×69	11.53	11.10	2 650	30	96	4.5	86	18	M3×19
PRP 29×92	LRB 29×92	13.13	12.70	6 450	41	120	4.5	110	27	M3×25
PRP 38×132	LRB 38×132	16.28	15.88	12 000	51	157	4.5	147	35	M5×38

B BLOCK

Ball Screw

B-1 Selection Guide to NSK Ball Screw

- 1. Features of NSK Ball Screws **B1**
- 2. Structure of a Ball Screw **B3**
 - 2.1 Ball Recirculation System **B4**
 - 2.2 Preload System **B5**
- 3. Ball Screw Series **B7**
 - 3.1 Ball Screw Classification **B7**
 - 3.2 Product External **B9**
- 4. Procedures to Select Ball Screw **B17**
 - 4.1 Flow Chart for Selection ... **B17**
 - 4.2 Accuracy Grades **B19**
 - 4.3 Axial Play **B20**
 - 4.4 Screw Shaft Diameter, Lead, and Stroke **B21**
 - 4.5 Manufacturing Capability for Screw Shaft **B25**
 - 4.6 Outside Shapes of Ball Nut **B26**
 - 4.7 Shaft End Configuration ... **B27**
- 5. When Placing Orders **B31**
 - 5.1 When Ordering Standard Ball Screws **B31**
 - 5.2 When Ordering Made-to-Order Ball Screws **B33**

B-2 Technical Description of Ball Screws

- 1. Accuracy **B37**
 - 1.1 Lead Accuracy **B37**
 - 1.2 Thermal Expansion and Target Value of Specified Travel **B40**
 - 1.3 Mounting Accuracy and Tolerance of Ball Screws ... **B41**
 - 1.4 Automatic Lead Accuracy Measuring System of NSK **B43**
- 2. Static Load Limitation **B44**
 - 2.1 Buckling Load **B44**
 - 2.2 Yield by Tensional/Compressive Stress **B46**
 - 2.3 Permanent Deformation at the Ball Contact Point ... **B46**
- 3. Permissible Rotational Speed **B47**
 - 3.1 Critical Speed of the Screw Shaft **B47**
 - 3.2 $d \cdot n$ Value **B50**
- 4. Supporting Conditions for Calculation of Buckling Load and Critical Speed **B51**
- 5. Life (Dynamic Load Limitation) **B53**
 - 5.1 Life of Ball Screw **B53**
 - 5.2 Fatigue Life **B53**
 - 5.3 Ball Screw and Hardness .. **B55**
 - 5.4 Wear Life **B55**
- 6. Preload and Rigidity **B56**
 - 6.1 Elastic Deformation of Preloaded Ball Screw ... **B56**
 - 6.2 Rigidity of the Feed Screw System **B57**
- 7. Friction Torque and Drive Torque **B62**
 - 7.1 Friction Torque **B62**
 - 7.2 Drive Torque **B63**
- 8. Even Load Distribution in Ball Nut (In Case of Ball Screws for High-Load Drive) **B65**

- 9. Lubrication of Ball Screw ... **B67**
- 10. Dust Prevention for Ball Screw **B68**
- 11. Rust Prevention and Surface Treatment of Ball Screws ... **B69**
- 12. Ball Screw Specifications for Special Environments **B70**
 - 12.1 Clean Environments **B70**
 - 12.2 Measures for Use Under Vacuum **B70**
- 13. Noise and Vibration **B71**
 - 13.1 Consideration to Lowering Noise **B71**
 - 13.2 Consideration to Operational Characteristics **B72**
 - 13.3 Consideration to Ball Screw Support System **B72**
- 14. Installation of Ball Screw **B73**
 - 14.1 Installation Procedure for Machine Tools, Where High Installation Accuracy Is Required **B74**
 - 14.2 Installation Procedure for General Industrial Machinery **B79**
- 15. Precautions for Designing Ball Screw **B83**
 - 15.1 Safety System **B83**
 - 15.2 Design Cautions to Assembling Ball Screw **B83**
 - 15.3 Effective Stroke of Ball Screw **B85**
 - 15.4 Matching after Delivery ... **B85**
 - 15.5 "NSK K1™" Lubrication Unit **B85**
- 16. Shaft End Machining **B86**
- 17. Ball Screw Selection Exercise **B87**
- 18. Reference **B101**
- 19. Guide to Technical Services **B102**
- 20. Precautions When Handling Ball Screws **B103**

B-3 Ball Screw Dimension Table

- 1. Dimension Table and Reference Number of Standard Ball Screws
 - 1.1 Compact FA Series **B107**
 - 1.2 High-Speed SS Series **B147**
 - 1.3 Finished Shaft End
 - MA Type, Miniature, Fine Lead ... **B159**
 - FA Type for Small Equipment ... **B181**
 - SA Type for Machine Tools ... **B217**
 - 1.4 Finished Shaft End
 - KA Type Stainless Steel Product .. **B273**
 - 1.5 Blank Shaft End
 - MS Type, Miniature, Fine Lead ... **B301**
 - FS Type for Small Equipment .. **B309**
 - SS Type for Machine Tools **B321**
 - 1.6 Ball Screws for Transfer Equipment **B349**
 - 1.7 Accessories **B389**
- 2. Dimension Table and Reference Number of Standard Nut Ball Screws
 - 2.1 End Deflector Type **B431**
 - 2.2 Tube Type **B437**
 - 2.3 Deflector (bridge) Type **B471**
 - 2.4 End Cap Type **B485**
- 3. Dimension Table and Reference Number of Application-Oriented Ball Screws
 - 3.1 HMD Type for High-Speed Machine Tools **B495**
 - 3.2 HMS Type for High-Speed Machine Tools **B499**
 - 3.3 HMC Type for High-Speed Machine Tools **B503**
 - 3.4 BSL™ Type for Miniature Lathes ... **B509**
 - 3.5 For High-Load Drives
 - 3.5.1 HTF-SRC Type **B513**
 - 3.5.2 HTF-SRD Type **B517**
 - 3.5.3 HTF Type **B521**
 - 3.6 For Contaminated Environments
 - 3.6.1 VSS Type **B533**
 - 3.6.2 Ball Screw with X1 Seals for Contaminated Environments and Grease Retention .. **B537**
 - 3.7 TW Series for Twin-Drive Systems ... **B543**
 - 3.8 For High Precision Machine Tools
 - 3.8.1 Hollow Shaft Ball Screws **B544**
 - 3.8.2 Nut Cooling Ball Screws ... **B549**
 - 3.9 ND Series for Nut-Rotatable Drives .. **B553**
 - 3.10 Σ Series for Robots **B561**
 - 3.11 Ball Screw with L1 Seal designed for Minimal Grease Splatter **B573**
 - 3.12 Equipped with "NSK K1™" Lubrication Unit ... **B577**
 - 3.13 Special Ball Screws **B583**

B1
-**B36**

B37
-**B104**

B105
-**B584**

B-1 Selection Guide to NSK Ball Screw

B-1-1 Features of NSK Ball Screws

(1) Quick delivery

- Standard ball screws are for short lead time.
- Precision ball screws with finished shaft end
Compact FA Series, MA Type, FA Type, SA Type, KA Type
 - Precision ball screws with blank shaft end
MS Type, FS Type, SS Type, HSS Type
 - Ball screws for transfer equipment with finished shaft end
VFA Type, RMA Type
 - Ball screws for transfer equipment with blank shaft end
RMS Type, R Series

(2) Competitive prices

NSK reduces cost by well-planned mass production of standardized items. We rank the best in the world production of ordered items. We are able to offer our products at competitive prices by producing similar items in the same production group.

(3) Unparalleled accuracy

NSK utilizes its unique grinding technique and measuring equipment for top-notch precision.

(4) Superb durability

NSK uses thoroughly purified alloy steel for superb durability.

(5) No backlash, and unparalleled rigidity

NSK ball screws use Gothic arch grooves as shown in Fig. 1.1 to minimize the clearance between the balls and grooves. Further, an application of preload makes no backlash possible. As providing controlled preload is easy, appropriate rigidity is obtained. As the Gothic arch also minimizes the clearance between the balls and the grooves, the backlash is minimized without applying preload.

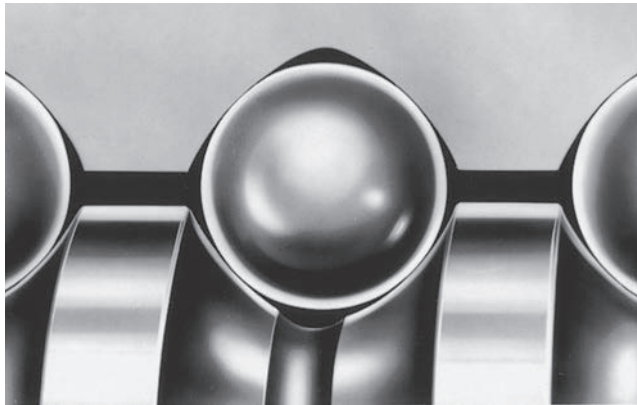

Fig. 1.1 Ball groove profile of NSK ball screw

(6) Smooth movement assures high efficiency

When the circular-arc groove is used for the ball screws, balls are wedging into the grooves of ball nut and ball screw shaft. But this phenomenon does not happen in the Gothic arch groove. The Gothic arch groove, along with the low friction that is inherent nature of ball screw, is accountable for a smooth and highly efficient conversion of motion as shown in Fig. 1.2.

(7) Optimal units available

Utilizing bearing technology, NSK produces high quality support units (for light load type to be used for small equipment and heavy load type to be used for machine tools) which are exclusive for ball screws. These units are standardized. NSK also offers quality-assured accessories such as lock nuts to tighten bearings, travel stoppers to prevent overrun, and sealing units to cool hollow shaft ball screws.

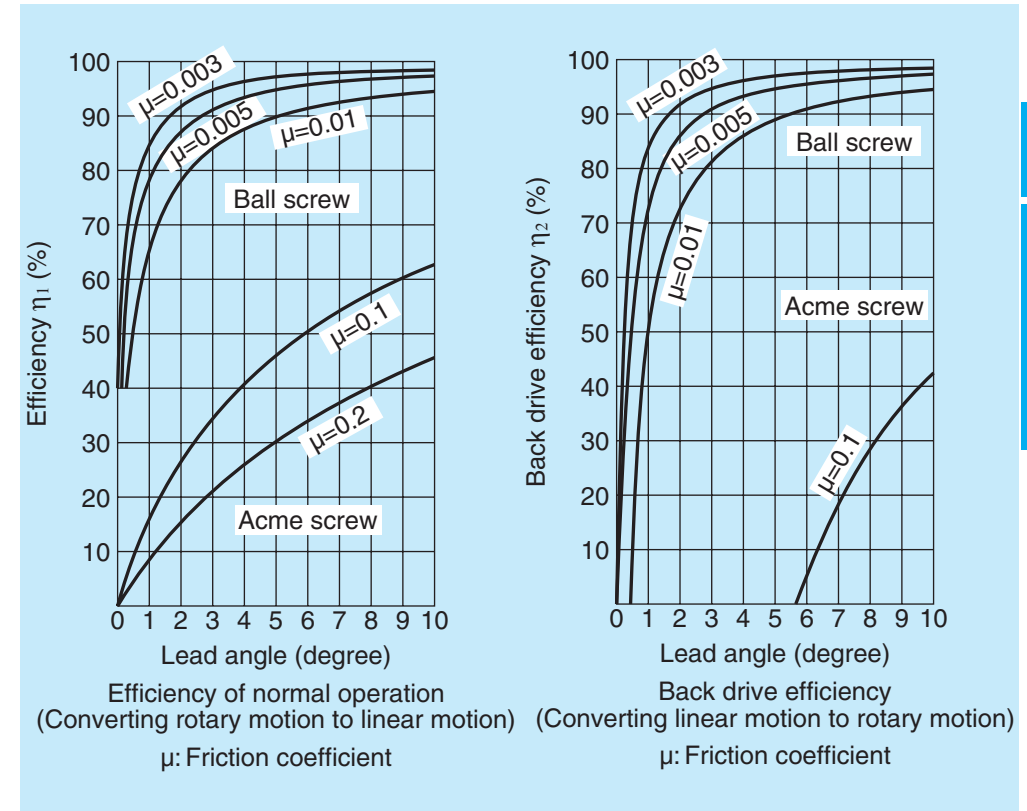

Fig. 1.2 Mechanical efficiency of ball screws

B-1-2 Structure of a Ball Screw

Balls are placed between the screw shaft and nut, and roll. This system is called a "ball screw." To keep the balls recirculating continually, this system requires a screw shaft, a nut, balls, and recirculation components as basic items. A ball screw has the following functions.

- (1) Converting motion: Changing rotary motion to linear motion (normal operation); Changing linear motion to rotary motion efficiently (back-drive operation).
- (2) Increasing power: A small torque is converted to a large thrust force.
- (3) Positioning: Sets accurate position in linear motion.

B-1-2.1 Ball Recirculation System

A ball recirculation system is categorically most important, as well as the preload system, to classify the structure of ball screw.

As shown in **Table 2.1**, four types of ball recirculation system are used for the NSK ball screws.

Table 2.1 Ball screw recirculation system

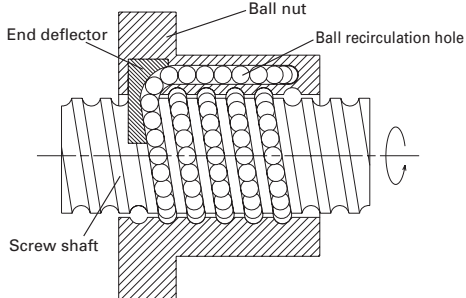
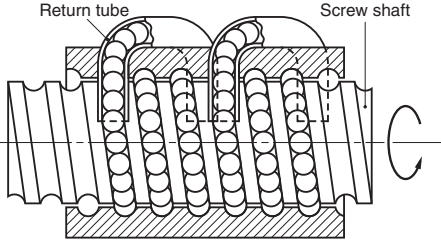
End deflector type	Ball return tube type
	
<p>[Structure] Balls are smoothly picked up in the tangential direction at the end of nut, and recirculated via a hole in the nut. If the balls are picked up at the middle of the nut, it is called middle deflector type.</p> <p>[Features] · Small nut outside diameter allows compact nut design. · Low noise, high speed.</p>	<p>[Structure] Balls are recirculating through a pipe (ball return tube) of optimized size, bridging the start and end of recirculation.</p> <p>[Features] · Adapt to various specifications. (screw shaft diameter, lead)</p>

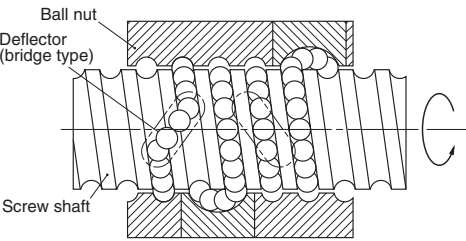
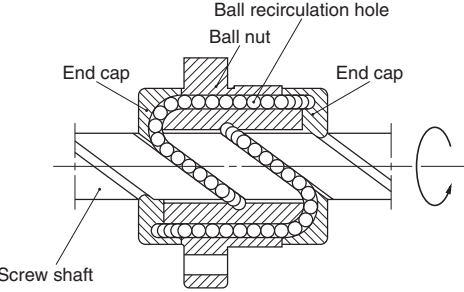
Deflector (bridge) type	End cap type
	
<p>[Structure] Balls are recirculated by a horseshoe shaped deflector bridging the adjacent ball thread grooves.</p> <p>[Features] · Suitable for fine lead ball screws. · Small nut outside diameter, allows compact nut design.</p>	<p>[Structure] Balls are picked up by an end cap placed at both ends of the nut, and recirculated via a hole through the nut.</p> <p>[Features] · Suitable for large lead ball screws. · Not universal due to complex recirculation structure.</p>

B-1-2.2 Preload system

There are four systems to apply preload to NSK ball screws depending on the application.

Table 2.2 Preload system for ball screws

Preload system	Double nut preload (D-Preload)	Offset preload (Z-Preload)
Structure		
Description	<p>Uses two nuts, and inserts a spacer between them to apply the preload. In general, a spacer is thicker (by the deformation equivalent to the preload) than the actual space between two nuts. However, a thin spacer is inserted in some cases.</p>	<p>To apply preload, the lead near the center of the nut is offset by the volume equivalent to preload (α). This method is like to creating a preload system similar to the double nut preload (D-preload) by a single ball nut, thus enabling a compact nut design.</p>
Nut length	Long	Medium
Torque characteristics	○	○
Rigidity	◎	◎

Preload system	Oversize ball preload (P-Preload)	Spring preloaded double nut (J-Preload)
Structure		
Description	<p>Balls slightly larger than the ball groove space (over-size balls) are inserted to allow them to contact at four points. Provides better torque characteristics in the low torque range.</p>	<p>A spring is used as a spacer of D-Preload. Must be used with discretion in its varied rigidity by load direction.</p>
Nut length	Short	Long
Torque characteristics	○	◎
Rigidity	○	△

B-1-3 Ball Screw Series

B-1-3.1 Ball Screw Classification

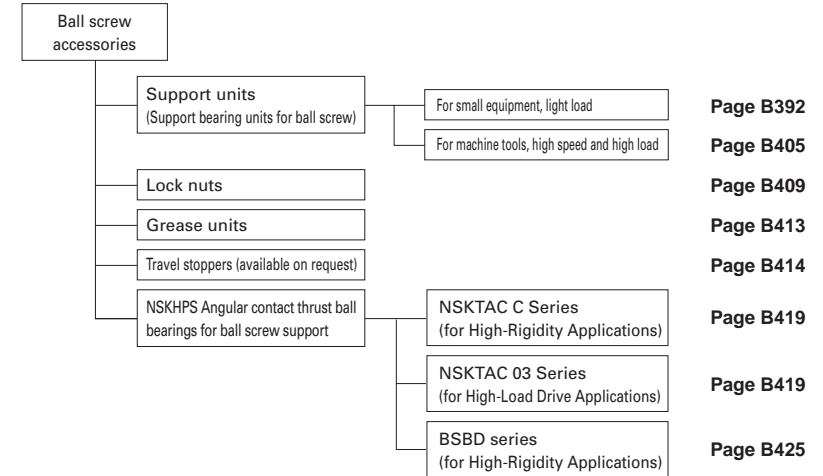
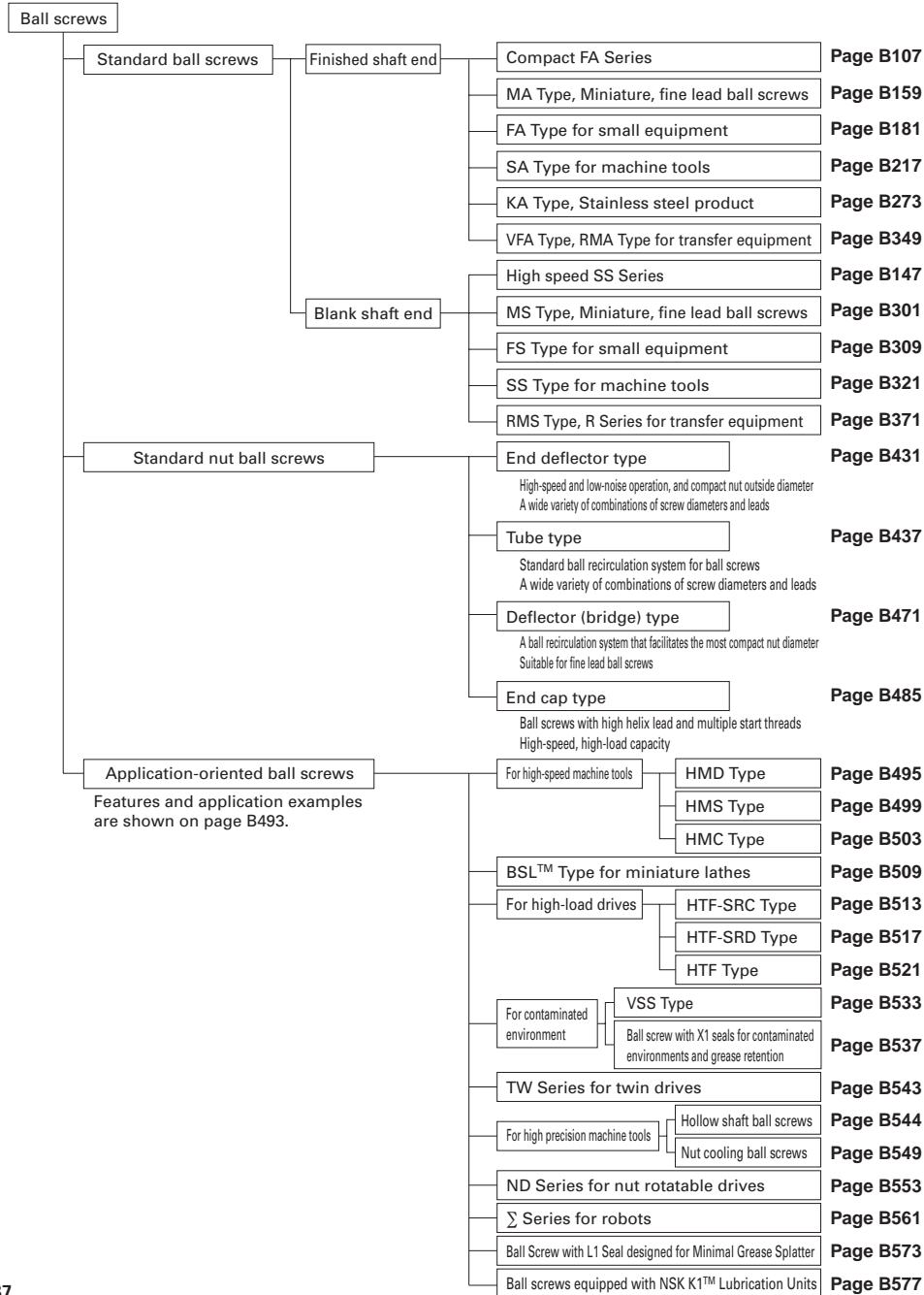

Lead classification

Classification	Lead ratio $K = \text{lead } l / \text{shaft diameter } d$
Fine	$K < 0.5$
Medium	$0.5 \leq K < 1$
High helix	$1 \leq K < 2$
Ultra high helix	$2 \leq K$

B-1-3.2 Product Externals

(1) Ball screws

● Standard ball screws

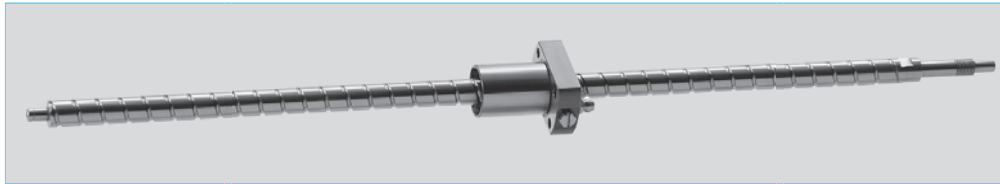

Fig. 3.1 Finished shaft end compact FA Series

Page B107

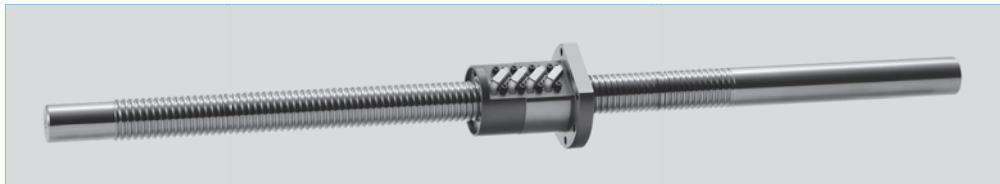

Fig. 3.2 Blank shaft end high-speed SS Series

Page B147

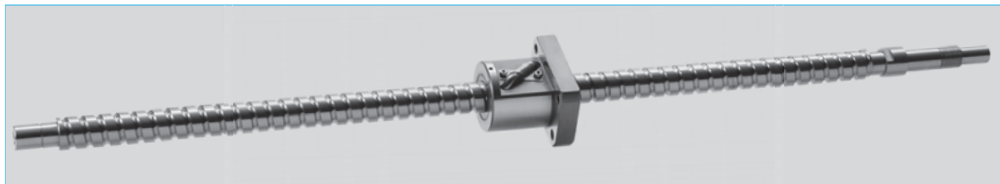

Fig. 3.3 Finished shaft end MA type, FA type and SA type

Page B157

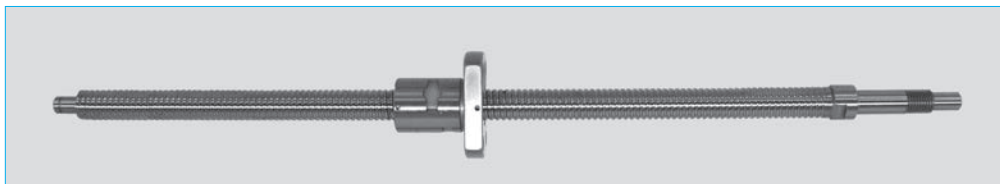

Fig. 3.4 Finished shaft end KA type

Page B273

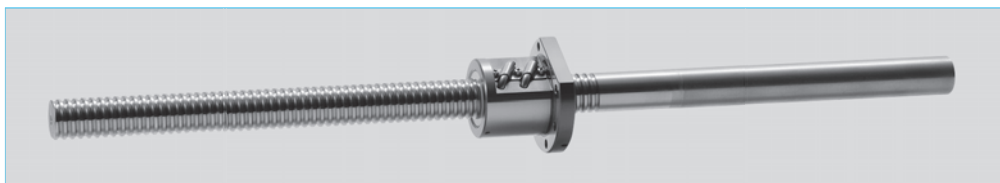

Fig. 3.5 Blank shaft end MS type, FS type and SS type

Page B299

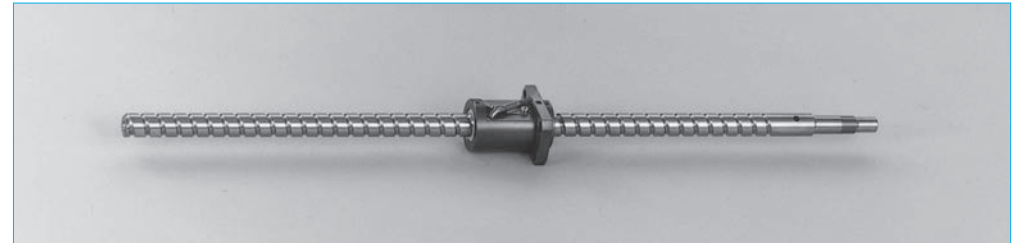

Fig. 3.6 Finished shaft end VFA type for transfer equipment

Page B349

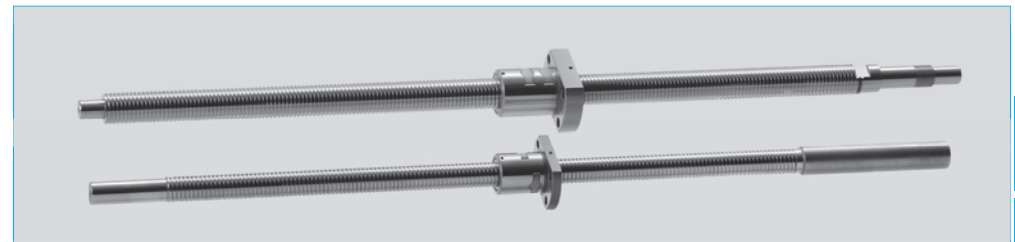

Fig. 3.7 Finished shaft end RMA type and blank shaft end RMS type for transfer equipment

Page B349

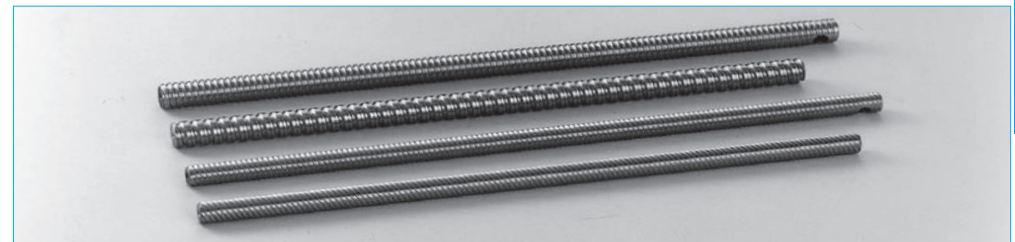

Fig. 3.8 Blank shaft end R series for transfer equipment

Page B349

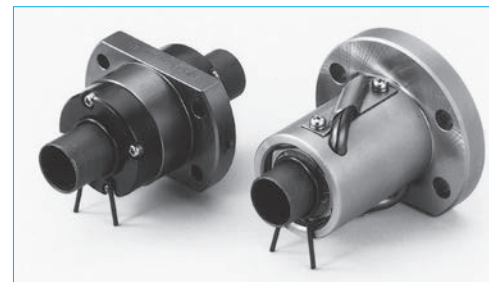

Fig. 3.9 R series nut assembly for transfer equipment

Page B349

●Standard nut ball screws

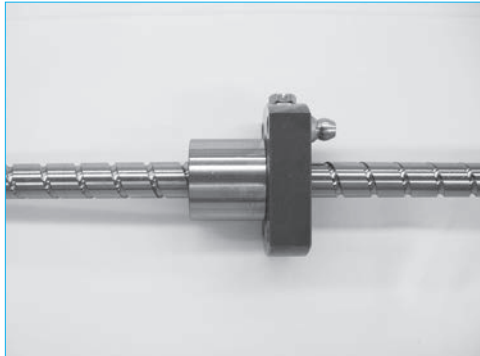

Fig. 3.10 End deflector type Page B431

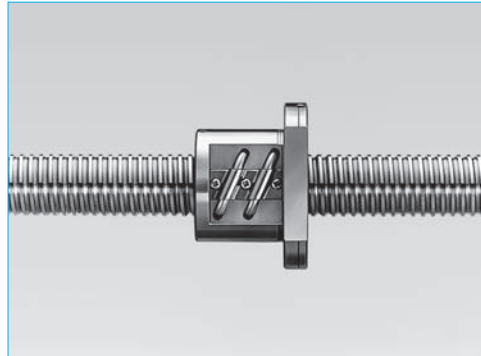

Fig. 3.11 Tube type Page B437

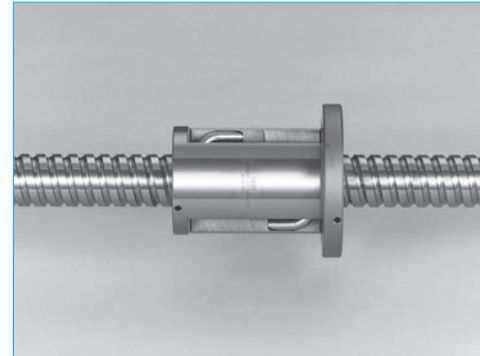

Fig. 3.16 HMC type for high-speed machine tools Page B503

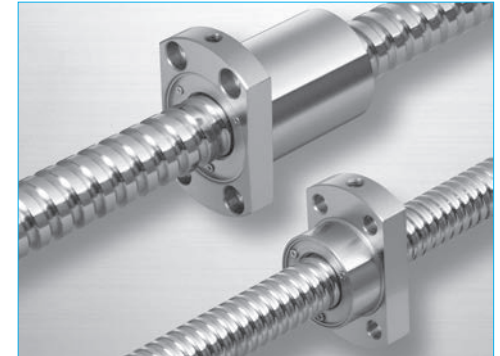

Fig. 3.17 BSL™ type for miniature lathes Page B509

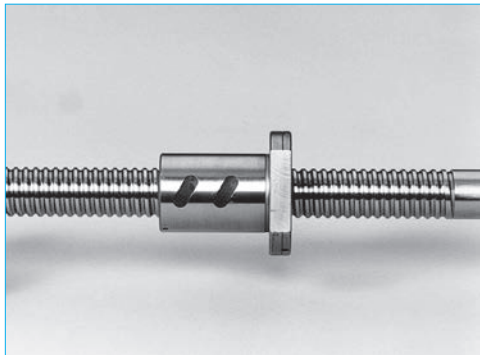

Fig. 3.12 Deflector (bridge) type Page B471

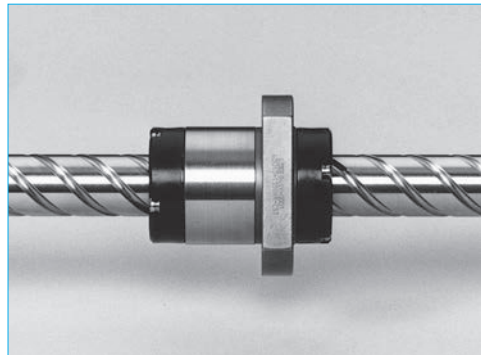

Fig. 3.13 End cap type Page B485

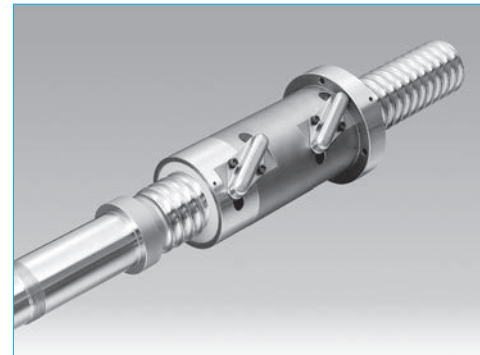

Fig. 3.18 HTF-SRC type for high-load drives Page B513

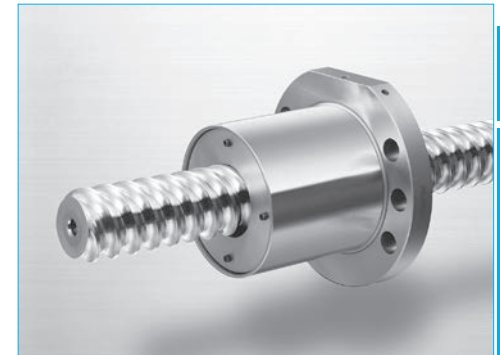

Fig. 3.19 HTF-SRD type for high-load drives Page B517

●Application-oriented ball screws



Fig. 3.14 HMD type for high-speed machine tools Page B495



Fig. 3.15 HMS type for high-speed machine tools Page B499

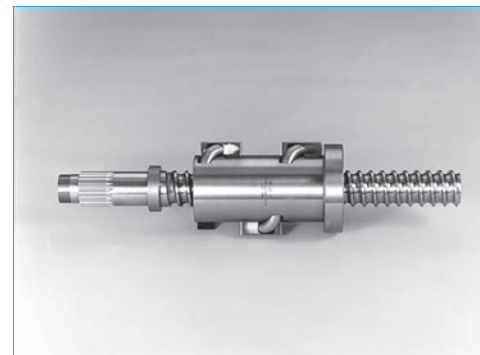

Fig. 3.20 HTF type for high-load drives Page B521

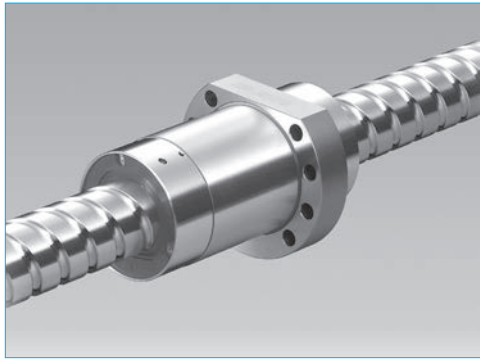

Fig. 3.21 VSS type for contaminated environments Page B533



Fig. 3.22 Ball screw with X1 seals for contaminated environments and grease retention Page B537

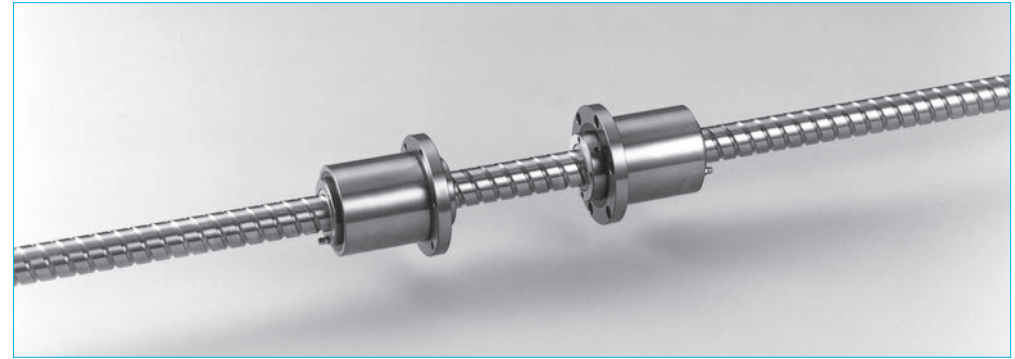

Fig. 3.26 ND series for nut-rotatable drives Page B553

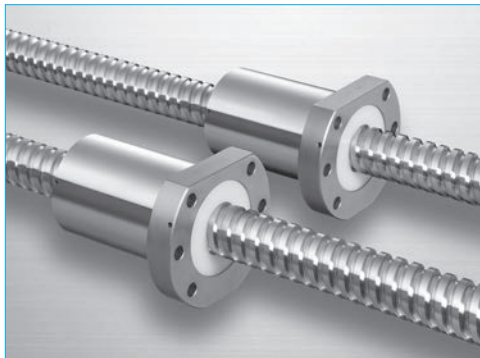

Fig. 3.23 TW series for twin-drive systems Page B543

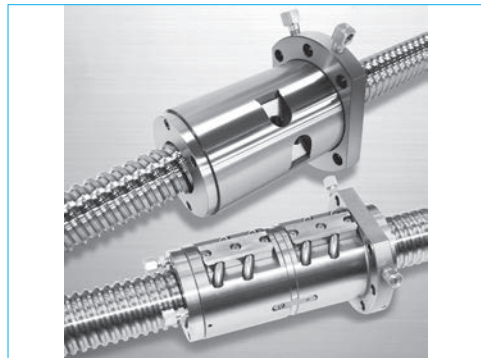

Fig. 3.24 Nut cooling ball screws for high precision machine tools Page B549

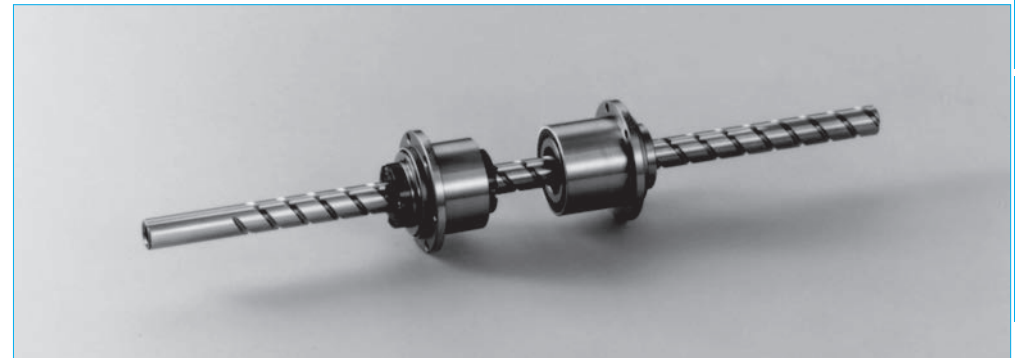

Fig. 3.27 Σ series for robots Page B561

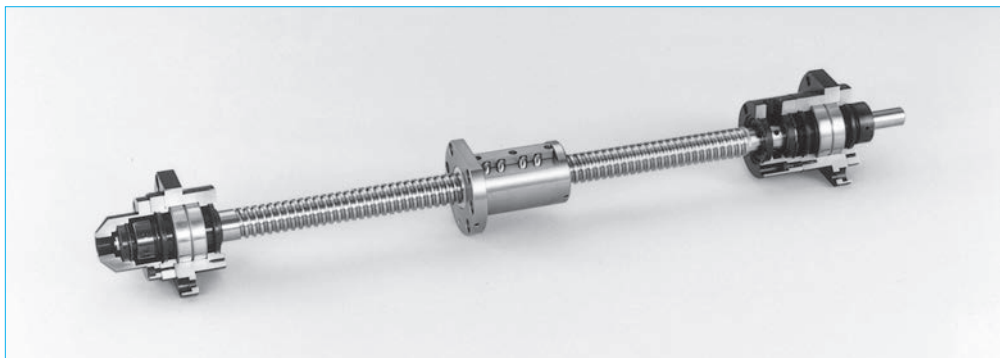

Fig. 3.25 Hollow shaft ball screws for high-precision machine tools Page B544



Fig. 3.28 Ball Screw with L1 Seal designed for Minimal Grease Splatter Page B573

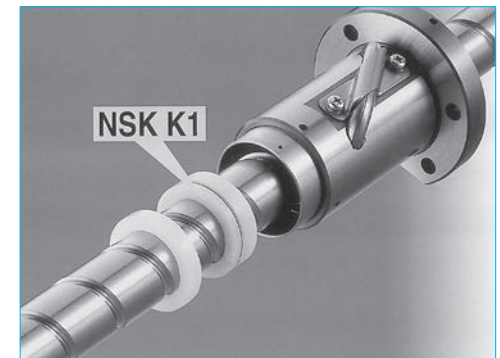

Fig. 3.29 Ball screws equipped with NSK K1™ lubrication units Page B577

(2) Standard accessories



Fig. 3.29 Support units Page B392
(for small equipment, light load)



Fig. 3.30 Support units Page B392
(for small equipment, light load, low-profile)



Fig. 3.35 Lock nuts for high load Page B410



Fig. 3.36 NSK hand grease pump unit Page D19



Fig. 3.31 Support kits for RMA and RMS types Page B401

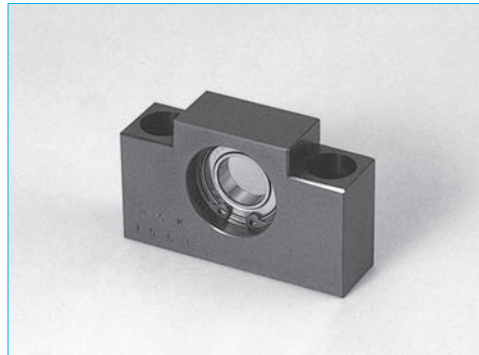

Fig. 3.32 Support unit for VFA type Page B402
(simple support side)



Fig. 3.37 NSK grease Page B413, D19

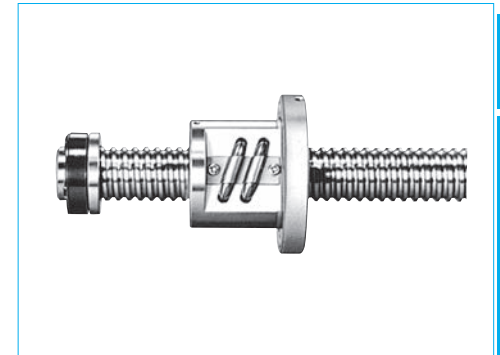

Fig. 3.38 Travel stoppers (by order) Page B414



Fig. 3.33 Support units Page B407
(for machine tools, high speed, heavy load)



Fig. 3.34 Lock nuts for light load Page B409



Fig. 3.39 Ball screw support bearings Page B419
NSKTAC C Series, NSKTAC 03 Series

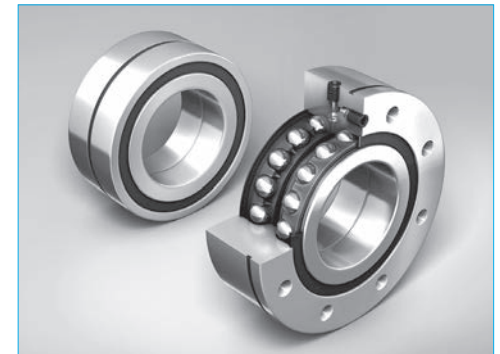

Fig. 3.40 Ball screw support bearings Page B425
BSBD series

B-1-4 Procedures to Select Ball Screw

B-1-4.1 Flow Chart for Selection

When selecting a ball screw, you have to review a variety of use conditions and requirements such as applied loads, speeds, motion strokes, positioning accuracy, required life and operating environment. You require a multiple inspection because some of these conditions force a ball screw to have conflicting characteristics.

(1) Standard ball screw

The chart below is one of the selection procedures. To take advantage of prompt delivery and reasonable prices, this procedure focuses on the standardized ball screws.

NSK offers a ball screw selection program, and also has a service to select appropriate items using data file compiled by our knowledge and experience.

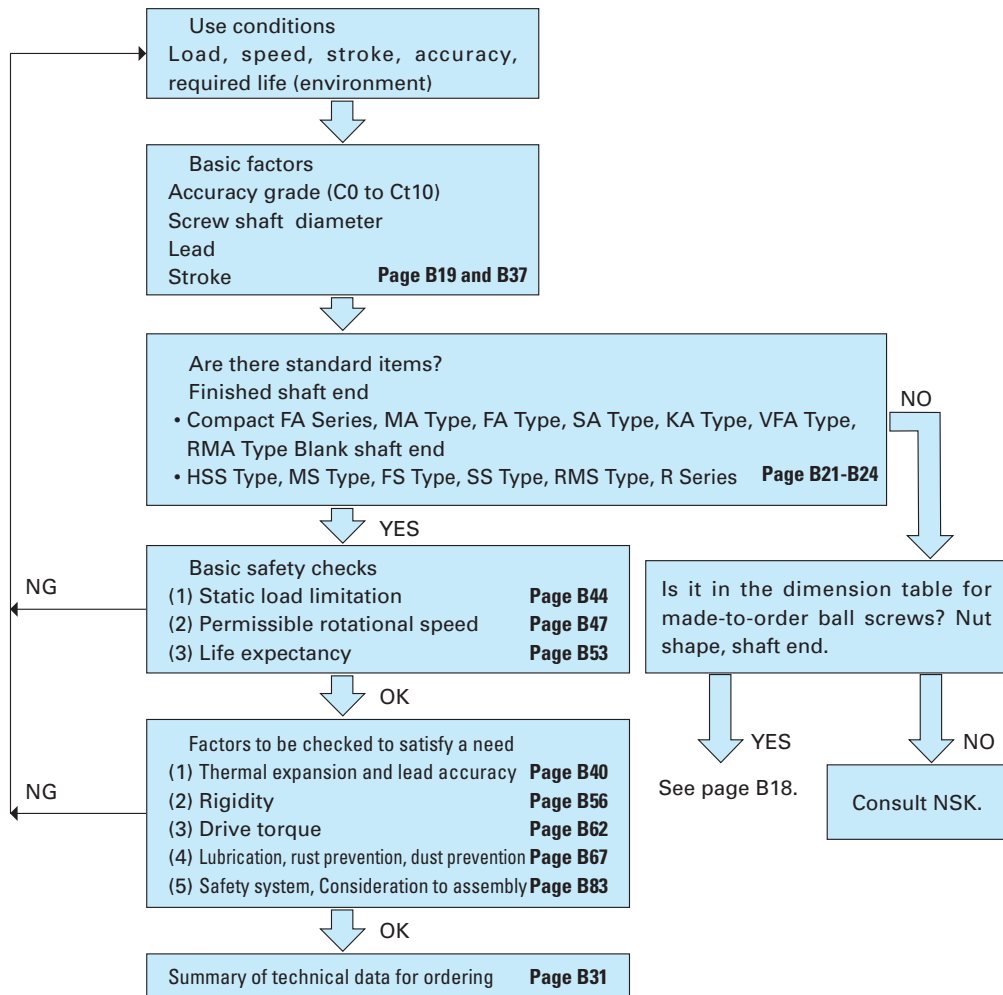

(2) Made-to-order ball screws

Dimensions and specifications can be decided individually for the application-oriented ball screws and standard nut ball screws. Procedures are as follows. Refer to the selection exercises on page B87.

Table 4.4 is "Combinations of screw shaft diameter and leads for basic type ball screw." Please consult

NSK if you require the types that are not listed in the table.

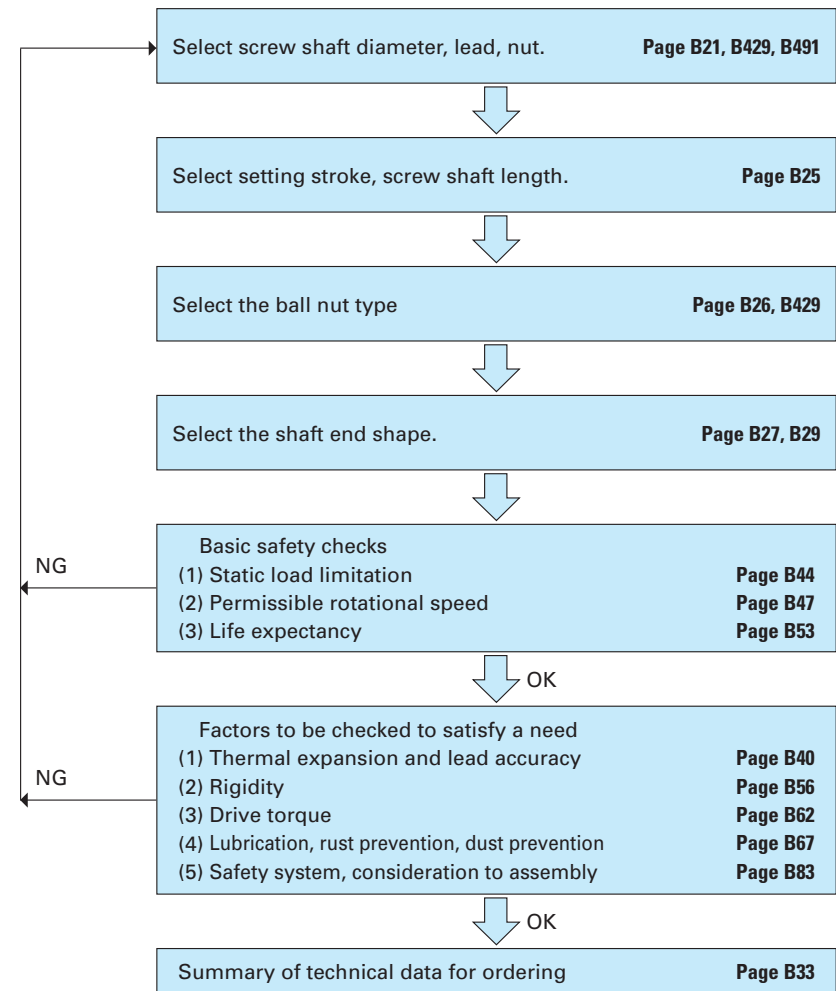

B-1-4.2 Accuracy Grades

Table 4.1 shows examples of how to select accuracy grade for a specific use. These practical cases are based on NSK's experience. The circles indicate the range of the accuracy grade in actual use. The double circles indicate accuracy grades most frequently used among the cases marked with the single circle. These

symbols help to select the accuracy grade of ball screws temporarily. To confirm whether a specific ball screw accuracy grade satisfies requirements in positioning accuracy in actual use, refer to "Technical Description" and "Mean travel deviation and travel variation." (page B38)

Table 4.1 Accuracy grades of ball screw and their application

Application		NC machine tools																					
		Lathes		Milling machines Boring machines		Machining centers		Drilling machines		Jig boring machines		Grinders		Electric discharge machines		Wire cuttings Electric discharge machines		Punch press		Laser cutting machines		Woodworking machines	
Axis		X	Z	XY	Z	XY	Z	XY	Z	XY	Z	XY	Z	XY	Z	XY	Z	XY	Z	XY	Z	XY	Z
Accuracy grade	C0	○								○	○	○											
	C1	○		○		○				◎	◎	○	○	○		○	○						
	C2	○		○	○	○	○					◎	○	○	○	○	○						
	C3	◎	○	◎	○	○	○	○				◎	◎	◎	◎	◎	○	○	○	○	○	○	○
	C5	◎	◎	◎	◎	◎	◎	◎	◎					◎	◎	◎	◎	◎	◎	◎	◎	◎	◎
	Ct7																						◎
	Ct10																						○

Application		Semiconductor/associated industry						Industrial robots						Steel mills equipment		Plastic injection molding machines		Three-dimensional coordinate measuring machines		Office machines		Image processing equipment		Nuclear power		
		General industrial machines, Machines for specific use		Lithographic machines		Chemical processing equipment		Wire bonders		Probers		Electric component mounted devices		Printed circuit board drilling machines		Cartesian type		Articulate type		SCARA type						
Accuracy grade		Assembly other purposes	Assembly other purposes	Assembly other purposes	Assembly other purposes	Assembly other purposes	Assembly other purposes	Assembly other purposes	Assembly other purposes	Assembly other purposes	Assembly other purposes	Assembly other purposes	Assembly other purposes	Assembly other purposes	Assembly other purposes	Assembly other purposes	Assembly other purposes	Assembly other purposes	Assembly other purposes	Assembly other purposes	Assembly other purposes	Assembly other purposes	Assembly other purposes	Assembly other purposes	Assembly other purposes	Assembly other purposes
C0																										
C1		◎		◎	◎		○																			
C2					○	◎	○	○																		
C3	○		○			○	◎	○		○		○		○		○		○		○		○		○		○
C5	◎		○			◎	◎	◎	◎	◎	◎	◎	◎	◎	◎	◎	◎	◎	◎	◎	◎	◎	◎	◎	◎	◎
Ct7	◎		◎				○	◎	◎	◎	◎	◎	◎	◎	◎	◎	◎	◎	◎	◎	◎	◎	◎	◎	◎	
Ct10	○		○					○		○		○		○		○		○		○		○		○		

B-1-4.3 Axial Play

Table 4.2 indicates the combinations of NSK ball screw accuracy grades and axial play. Select an axial play which satisfies the required accuracy in backlash, positioning and repeatability. Ranges of available ball thread effective length in relation to accuracy grade and axial play are shown in **Table 4.3**. Please note that if the effective length exceeds the

range, the axial play may become partially negative (preloaded condition).

For the axial play of Ct10 grade (ball screws for transfer equipment), refer to the R series dimension tables.

Table 4.2 Combinations of accuracy grades and axial play

Axial play	Z	T	S	N	L
	0 mm (Preload)	0.005 mm or less	0.020 mm or less	0.050 mm or less	0.3 mm or less
C0	C0Z	C0T	—	—	—
C1	C1Z	C1T	—	—	—
C2	C2Z	C2T	—	—	—
C3	C3Z	C3T	C3S	—	—
C5	C5Z	C5T	C5S	C5N	—
Ct7	—	—	C7S	C7N	—

The combination codes shown in the table are NSK reference number.

Table 4.3 Maximum effective thread length in combination of accuracy grade and axial play

Unit: mm

Screw shaft diameter	Effective length of the screw thread (maximum)				
	Axial play T (0.005 mm or under)		Axial play S (0.020 mm or under)		
	C0 – C3	C5	C3	C5	Ct7
4 – 6	80	100	80	100	—
8 – 10	250	200	250	300	—
12 – 16	500	400	500	600	700
20 – 25	800	700	1 000	1 000	1 000
28 – 40	1 000	800	2 000	1 500	1 500
45 – 63	1 200	1 000	2 500	2 000	2 000
80 – 125	—	—	4 000	3 000	3 000

Note: Refer to **Table 4.8** (page B25) for the available length of screw shaft (maximum length). Also, axial play of code N does not become partial negative play if it is within the available range of effective ball thread length.

B-1-4.4 Screw Shaft Diameter, Lead, and Stroke

Choose a screw shaft diameter and stroke based on the allowable space for ball screw installation. A lead should be set based on the required running speed, and should give some allowance to the maximum rotational speed of the motor.

(1) Standard ball screw

Tables 4.4 and 4.5 show the combinations of ball screw shaft diameter and leads, and range of stroke. From these tables, select the closest values to the shaft diameter, lead, and stroke which had been selected previously. Also, confirm detailed specifications and sizes in "Dimensional table of standard ball screw" (page B105).

Table 4.4 Screw shaft diameter, lead and stroke of standard ball screw

Shaft dia.	Lead	Stroke													
		- 50	- 100	- 150	- 200	- 250	- 300	- 350	- 400	- 450	- 500	- 550	- 600	- 650	
4	1	○													
	2	○													
	4	○													
6	1	○	○												
	2	○	○												
	4	○	○												
8	1	○	○												
	1.5	○	○												
	2	○	○												
	10	○	○												
	15	○	○												
	2	○	○												
10	2.5	○	○												
	4	○	○												
	5	○	○												
	10	○	○												
	20	○	○												
	30	○	○												
12	2.5	○	○												
	5	○	○												
	10	○	○												
14	5	○	○												
	8	○	○												
	10	○	○												
15	10	○	○												
	20	○	○												
	30	○	○												
16	2.5	○	○												
	5	○	○												
	16	○	○												
20	4	○	○												
	5	○	○												
	10	○	○												
	20	○	○												
	30	○	○												
	40	○	○												
25	4	○	○												
	5	○	○												
	6	○	○												
	10	○	○												
	20	○	○												
	30	○	○												
28	5	○	○												
	6	○	○												
	10	○	○												
32	8	○	○												
	10	○	○												
	25	○	○												
36	10	○	○												
	5	○	○												
	8	○	○												
40	10	○	○												
	12	○	○												
	20	○	○												
45	10	○	○												
	10	○	○												
50	10	○	○												
	12	○	○												

Note: See **Table 4.5** for KA Type in stainless steel product.

Table 4.5 Screw shaft diameter, lead and stroke of KA type in stainless steel product

Unit: mm

Shaft dia.	Lead	Stroke								
		- 150	- 200	- 250	- 300	- 350	- 450	- 500	- 650	- 1 050
6	1	●								
	8		●							
10	2		●							
	4	●		●		●				
12	2	●								
	5			●				●		
15	10				●			●		●
	20							●		●
16	2	●								
	20							●		●

●mark; PSS type, USS type, FSS type: ○mark; MA type, FA type, SA type: ▲mark; HSS type
 △mark; MS type, FS type, SS type: ✓mark; VFA type: ■mark; RMA type: □mark; RMS type

Unit: mm

Shaft dia.	Lead	Stroke																
		- 700	- 750	- 800	- 850	- 900	- 950	- 1 100	- 1 200	- 1 300	- 1 400	- 1 500	- 1 700	- 2 100	- 3 000			
4	1																	
	2																	
	4																	
6	1																	
	2																	
	4																	
8	1																	
	1.5																	
	2																	
	10																	
	15																	
	2																	
10	2.5																	
	4																	
	5																	
	10																	
	20																	
	30																	
12	2.5																	
	5																	
	10																	
14	5																	
	8																	
	10																	
15	10																	
	20																	
	30																	
16	2.5																	
	5																	
	16																	
20	4																	
	5																	
	10																	
	20																	
	30																	
	40																	
25	4																	
	5																	
	6																	
	10																	
	20																	
	30																	
28	5																	
	6																	
	10																	
32	8																	
	10																	
	25																	
36	10																	
	5																	
	8																	
40	10																	
	12																	
	20																	
45	10																	
	10																	
50	10																	
	12																	

Table 4.6 Screw shaft diameter, lead and standard screw shaft length of R Series Unit: mm

Screw shaft diameter	Lead	Standard screw shaft length									
		400	500	800	1 000	1 500	2 000	2 500	3 000	4 000	5 000
10	3	●		●							
	6	●		●							
12	8	●		●							
	12	●		●							
14	4		●		●						
	5		●		●						
15	20		●		●	●					
16	10		●		●	●					
	16		●		●	●					
18	32		●		●	●					
	8		●		●	●					
20	5		●		●		●				
	10		●		●		●				
	20		●		●		●				
	40		●		●	●					
25	5		●		●		●	●			
	10		●		●		●	●			
	25		●		●		●	●			
28	50		●		●		●	●			
	6		●		●		●	●			
32	10		●		●		●		●		
	32		●		●		●		●		
	64		●		●		●		●		
36	10		●		●		●		●		
	10		●		●		●		●		
40	40		●		●		●		●		
	80		●		●		●		●		●
	12		●		●		●		●		●
50	10		●		●		●		●		
	16		●		●		●		●		
	50		●		●		●		●		

(2) Made-to-order ball screws

Table 4.7 shows the combinations of screw shaft diameter and leads for made-to-order ball screws. For details, refer to the dimension tables from pages B429 and B491.

Table 4.7 Combinations of screw shaft diameter and leads for typical ball screw Unit: mm

Lead Screw shaft diameter	Standard screw shaft length																										
	0.5	1	1.5	2	2.5	3	4	5	6	8	10	12	14	15	16	20	25	30	32	36	40	50	60	64	80	100	
4	D	D																									
6	D	D		D						S		S															
8	D	D	D	D							S			S													
10		D		D	D		T	S			S																
12		D		D	D	D	T	S,T			S,T					S,C		S									
14				D		D		T		T																	
15								S			S,T						S					C					
16				D	D		T	T	T						T,C				C			C					
20				D			T	S,T D,B	T,D B	T	S,T				T	S,T C		S				S,C		S,C			
25				D			T	S,T D,B	T,D B	T,B	S,T D,B				T	S,T C	S,T C	S				S,C		S,C			C
28								T	T		T																
32				D			T	S,T D	T,D	T,D	S,T D,B V,F	S,T B			S,V	S,T V,N	T,N			S,T C,V N						S,C	
36								S,T	T		S,T F	S,F			S,H	S,H											
40				D				T,D	T,D	T,D	S,T D,F	S,T F			S,T H	S,H	S,T H,N	S,H	T,H N	H		S,T C,V N				S	
45											S,T F	S,T F			S,H	S,H	S,H	S,H	H	H							
50									T,D	T,D	T,D	S,T D,F	S,T D,F	F		S,T F	S,T D,H	S,T H,N	S,H	T,H N		T,N F	S,T C,V N				S
55											T,F	F	F		F	H	H	H	H								
63										D	D	T,D	D,F	F	F	T,D F	F		F			T,F	T				
80											T,D	T,D	F		T,F	T,D F	F							F			
100											D	T,D			T,F	T,D F	F										
120															F	F	F										
125															T	T											
140																F	F	F	F								
160																	F	F	F								
200																	F	F	F								

T: Tube type
D: Deflector(bridge) type
C: End cap type
S: End deflector type
H: HMC type, HMD type
F: HTF-SRC, HTF-SRD, HTF type
N: ND Series
B: BSL type
V: VSS type

B-1-4.5 Manufacturing Capability for Screw Shaft

Table 4.8 shows the manufacturing capability for the screw shaft overall length for each accuracy grade. The capability of large ball screw whose shaft diameter exceeds 100 mm is limited due to the

weight (indicated by * asterisk in the table). Please consult NSK in such a case. Also consult NSK if the screw shaft size you desire exceeds the size listed in **Table 4.8**.

Table 4.8 Manufacturing capability of screw shaft

Unit: mm

Accuracy grade Screw shaft diameter	C0	C1	C2	C3	C5	Ct7	Ct10
4	90	110	120	140	140	140	—
6	150	180	200	250	250	250	—
8	240	280	340	340	340	340	—
10	350	400	500	500	500	550	800
12	450	500	650	700	750	800	800
14	600	650	750	800	1 000	1 000	1 000
15	600	700	800	900	1 250	1 250	1 500
16	600	750	900	1 000	1 500	1 500	1 500
18	—	—	—	—	—	—	1 500
20	850	1 000	1 200	1 400	1 900	1 900	2 000
25	1 100	1 400	1 600	1 900	2 500	2 500	2 500
28	1 100	1 400	1 600	1 900	2 500	2 500	2 500
32	1 500	1 750	2 250	2 500	3 200	3 200	3 000 (4 000)
36	1 500	1 750	2 250	2 500	3 200	3 500	3 000
40	2 000	2 400	3 000	3 400	3 800	4 300	4 000 (5 000)
45	2 000	2 400	3 000	3 400	4 000	4 500	4 000
50	2 000	3 200	4 000	4 500	5 000	5 750	4 000
55	2 000	4 000	5 000	5 800	6 000	6 000	—
63	2 000	4 000	5 000	6 000	6 800	7 700	—
80	—	4 000	6 300	8 200	9 200	10 000	—
100	—	4 000	6 300	10 000	12 500	13 500	—
*120	—	—	—	—	—	13 500	—
*125	—	—	—	10 000	13 500	13 500	—
*140	—	—	—	—	—	10 000	—
*160	—	—	—	—	—	8 000	—
*200	—	—	—	—	—	5 000	—

Notes: 1. Values in parentheses of Ct10 are applicable to the ultra high helix lead ($l/d \geq 2$). Refer to dimension tables on B385 and following pages for details.
2. Please note that the range for small leads (3 mm or under) are also limited by the screw length.

B-1-4.6 Outside Shapes of Ball Nut

(1) Flange shape

Fig. 4.1 shows the available flange shape. Select the appropriate shape according to the nut installation condition. (**Fig. 4.2**)

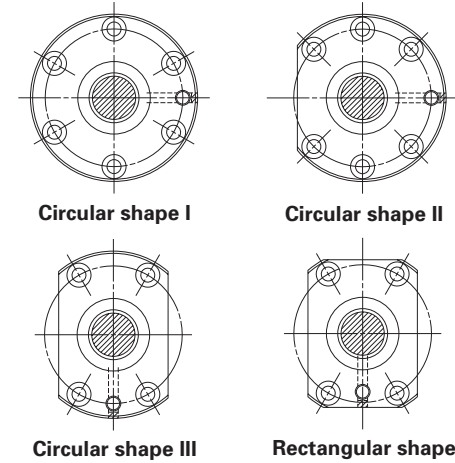

Fig. 4.1 Flange shape

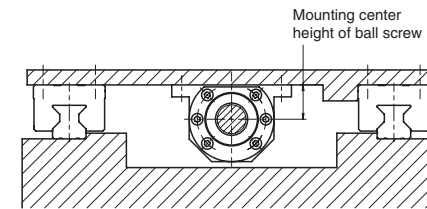

Fig. 4.2 Installation example

(2) Shapes of nut cross section

Cross-section of nuts are shown in **Fig. 4.3**. For detailed dimensions, refer to dimension table of nut.

- ① **Circular (round)**
The ball recirculation components are contained inside the circumference of the nut. It can be inserted in a round hole.
- ② **Tube-projecting type**
This shape is unique to the tube recirculation type. The nut outside diameter is small. However some recess must be given for housing because the ball recirculation tube protrudes from the circumference of the nut.

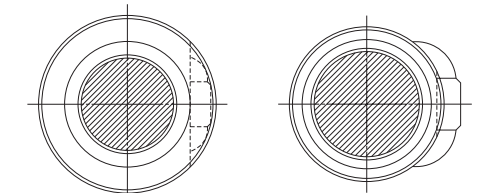

Fig. 4.3 Shape of the cross section of nut

B-1-4.7 Shaft End Configuration

(1) Standard shaft end dimensions

Tables 4.9 and 4.10 show shaft end types for NSK standard support units.

Refer to the dimension tables below when designing shaft ends of standard ball screw.

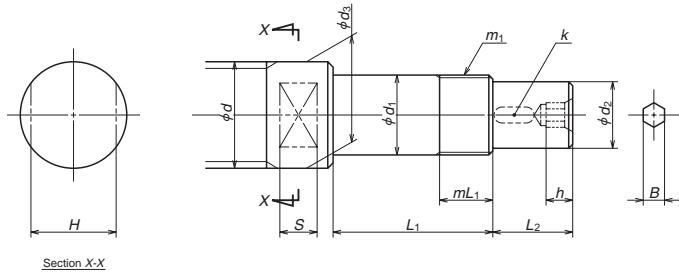

Fig. 4.4 Configuration of standard shaft end (drive side)

Table 4.9 Dimensions of shaft ends (drive side)

Unit: mm

Screw shaft diameter <i>d</i>	Bearing journal		Thread		Drive section			Seal section	Hexagon hole		Wrench flats		Support unit	
	Outside diameter	Length	Nominal spec.	Length	Outside diameter	Length	Key width	Outside diameter	Width across flats	Depth	Width across flats	Length	Reference No.	
	<i>d</i> ₁	<i>L</i> ₁	<i>m</i> ₁	<i>mL</i> ₁	<i>d</i> ₂	<i>L</i> ₂	<i>k</i>	<i>d</i> ₃	<i>B</i>	<i>h</i>	<i>H</i>	<i>S</i>		
4	6	22.5	M6×0.75	7	4.5	7.5	—	9.5	—	—	8	4.5	WBK06-01A	WBK06-11
6	6	22.5	M6×0.75	7	4.5	7.5	—	9.5	—	—	8	4.5	WBK06-01A	WBK06-11
8	8	27	M8×1	9	6	10	—	11.5	—	—	10	5.5	WBK08-01A	WBK08-11
10	8	27	M8×1	9	6	10	—	11.5	—	—	10	5.5	WBK08-01A	WBK08-11
12	10	30	M10×1	10	8	15	—	14	—	—	12	6.5	WBK10-01A	WBK10-11
14	12	30	M12×1	10	10	15	3	15	4	6	12	6.5	WBK12-01A	WBK12-11
15	12	30	M12×1	10	10	15	3	15	4	6	12	6.5	WBK12-01A	WBK12-11
16	12	30	M12×1	10	10	15	3	15	4	6	12	6.5	WBK12-01A	WBK12-11
20	15	40	M15×1	15	12	20	4	19.5	5	7	17	8.5	WBK15-01A	WBK15-11
	17	81	M17×1	23	12	29	4	20	5	7	22	10	WBK17DF-31H	
25	20	53	M20×1	16	15	27	5	25	6	8	22	10	WBK20-01	WBK20-11
	20	81	M20×1	23	15	39	5	25	6	8	22	10	WBK20DF-31H	
	20	53	M20×1	16	15	27	5	25	6	8	22	10	WBK20-01	WBK20-11
28	20	81	M20×1	23	15	39	5	28	6	8	24	12	WBK20DF-31H	
	25	62	M25×1.5	20	20	33	6	32	8	10	27	12	WBK25-01W	WBK25-11
	25	104	M25×1.5	26	20	51	6	32	8	10	27	12	WBK25DF-31H	
32	25	89	M25×1.5	26	20	51	6	32	8	10	27	12	WBK25DF-31H	
	25	104	M25×1.5	26	20	51	6	32	8	10	27	12	WBK25DF-31H	
	30	89	M30×1.5	26	25	61	8	40	10	12	—	—	WBK30DF-31H	
36	30	104	M30×1.5	26	25	61	8	36	10	12	30	13	WBK30DF-31H	
	30	89	M30×1.5	26	25	61	8	40	10	12	—	—	WBK30DF-31H	
	30	104	M30×1.5	26	25	61	8	40	10	12	—	—	WBK30DF-31H	
40	35	92	M35×1.5	30	30	63	8	45	12	14	—	—	WBK35DF-31H	
	35	107	M35×1.5	30	30	63	8	45	12	14	—	—	WBK35DF-31H	
	40	92	M40×1.5	30	35	78	10	50	14	18	—	—	WBK40DF-31H	
50	40	107	M40×1.5	30	35	78	10	50	14	18	—	—	WBK40DF-31H	
	40	107	M40×1.5	30	35	78	10	50	14	18	—	—	WBK40DF-31H	

Note: Low-profile support unit is available for compact FA Series.

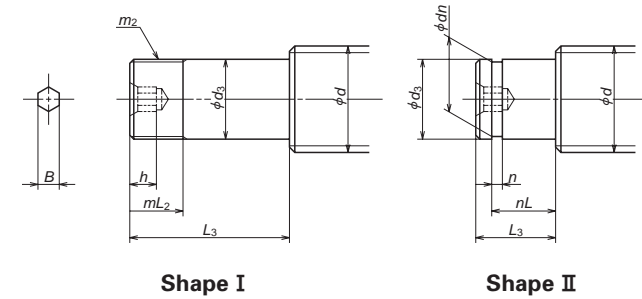

Fig. 4.5 Standard shaft end configuration (opposite to the drive side)

Table 4.10 Dimensions of shaft ends (opposite to the drive side)

Unit: mm

Screw shaft diameter <i>d</i>	Shape	Bearing journal		Thread for lock nut		Retainer ring groove			Hexagonal hole		Support unit	
		Outside diameter	Length	Nominal spec.	Length	Width	Groove diameter	Groove position	Width across flats	Depth	Reference No.	
		<i>d</i> ₁	<i>L</i> ₁	<i>m</i> ₂	<i>mL</i> ₂	<i>n</i>	<i>dn</i>	<i>nL</i>	<i>B</i>	<i>h</i>		
8	II	6	9	—	—	0.8	5.7	6.8	—	—	WBK08S-01	
	II	6	9	—	—	0.8	5.7	6.8	—	—	WBK08S-01	
12	II	8	10	—	—	0.9	7.6	7.9	—	—	WBK10S-01	
14	II	10	22(12)	—	—	1.15	9.6	9.15	4	6	WBK12S-01	
15	II	10	22(12)	—	—	1.15	9.6	9.15	4	6	WBK12S-01	
16	II	10	22(12)	—	—	1.15	9.6	9.15	4	6	WBK12S-01	
	II	15	25(13)	—	—	1.15	14.3	10.15	5	7	WBK15S-01	
25	II	20	19	—	—	1.35	19	15.35	6	8	WBK20S-01	
	I	20	53	M20×1	16	—	—	—	6	8	WBK20-01	WBK20-11
	I	20	81	M20×1	23	—	—	—	6	8	WBK20DF-31H	
28	II	20	19	—	—	1.35	19	15.35	6	8	WBK20S-01	
	I	20	53	M20×1	16	—	—	—	6	8	WBK20-01	WBK20-11
	I	20	81	M20×1	23	—	—	—	6	8	WBK20DF-31H	
32	II	25	20	—	—	1.35	23.9	16.35	8	10	WBK25S-01W	
	I	25	62	M25×1.5	20	—	—	—	8	10	WBK25-01W	WBK25-11
	I	25	89	M25×1.5	26	—	—	—	8	10	WBK25DF-31H	
36	II	25	20	—	—	1.35	23.9	16.35	10	12	(6205)	
	I	25	89	M25×1.5	26	—	—	—	10	12	WBK25DF-31H	
40	II	30	22	—	—	1.75	28.6	17.75	10	12	(6206)	
	I	30	89	M30×1.5	26	—	—	—	10	12	WBK30DF-31H	
45	II	35	25	—	—	1.75	33	18.75	12	14	(6207)	
	I	35	92	M35×1.5	30	—	—	—	12	14	WBK35DF-31H	
50	II	40	25	—	—	1.95	38	19.95	14	18	(6208)	
	I	40	92	M40×1.5	30	—	—	—	14	18	WBK40DF-31H	

(2) Shaft end configuration of R series ball screws for transfer equipment

Tables 4.11 and 4.12 show shaft end types for R Series.

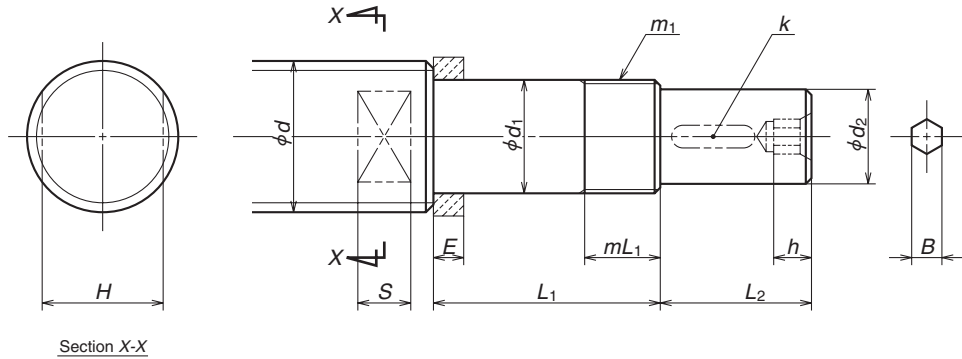

Fig. 4.6 R Series shaft end (drive side)

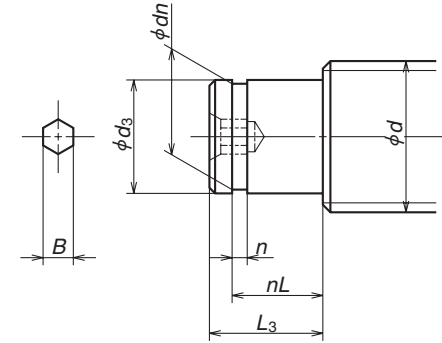

Fig. 4.7 Shaft end configuration of R Series (opposite to the drive side)

Table 4.11 Dimensions of R Series shaft ends (drive side)

Unit: mm

Screw shaft diameter <i>d</i>	Bearing journal		Thread for lock nut		Spacer Width <i>E</i>	Drive section			Hexagonal hole		Wrench flat		Support unit	
	Outside diameter <i>d_i</i>	Length <i>L₁</i>	Nominal spec <i>m₁</i>	Length <i>mL₁</i>		Outside diameter <i>d₂</i>	Length <i>L₂</i>	Key width <i>k</i>	Width across flats <i>B</i>	Depth <i>h</i>	Width across flats <i>H</i>	Length <i>S</i>	Reference No.	
10	6	27	M6×0.75	7	5.0	4.5	7.5	—	—	—	8	4.5	WBK06-01A	WBK06-11
12	8	32	M8×1	9	5.5	6	10	—	—	—	10	5.5	WBK08-01A	WBK08-11
14	10	35	M10×1	10	5.5	8	15	—	—	—	12	6.5	WBK10-01A	WBK10-11
15	10	35	M10×1	10	5.5	8	15	—	—	—	12	6.5	WBK10-01A	WBK10-11
16	12	35	M12×1	10	5.6	10	15	3	4	6	12	6.5	WBK12-01A	WBK12-11
18	12	35	M12×1	10	5.6	10	15	3	4	6	12	6.5	WBK12-01A	WBK12-11
20	15	50	M15×1	15	10	12	20	4	5	7	17	8.5	WBK15-01A	WBK15-11
25	17	53	M17×1	17	7	15	27	5	6	8	22	10	WBK17-01A	—
	20	64	M20×1	16	11	15	27	5	6	8	22	10	WBK20-01	WBK20-11
28	20	64	M20×1	16	11	15	27	5	6	8	22	10	WBK20-01	WBK20-11
32	25	76	M25×1.5	20	14	20	33	6	8	10	27	12	WBK25-01W	WBK25-11
36	25	76	M25×1.5	20	14	20	33	6	8	10	27	12	WBK25-01W	WBK25-11
40	30	89	M30×1.5	26	—	25	61	8	10	12	—	—	WBK30DF-31H	—
45	35	92	M35×1.5	30	—	30	63	8	12	14	—	—	WBK35DF-31H	—
50	35	92	M35×1.5	30	—	30	63	8	12	14	—	—	WBK35DF-31H	—

Note: The dimension *d_i* shall be smaller enough than the minor diameter of the ball screw thread to provide sufficient shoulder surface for the spacer.

Refer to "Precautions for Designing Ball Screw (page B83)".

Table 4.12 Dimensions of R Series shaft ends (opposite to the drive side)

Unit: mm

Screw shaft diameter <i>d</i>	Bearing journal		Retaining ring groove			Hexagonal hole		Support unit Numbers in parentheses are bearing reference numbers.
	Outside diameter <i>d₃</i>	Length <i>L₃</i>	Width <i>n</i>	Groove diameter <i>dn</i>	Groove position <i>nL</i>	Width across flats <i>B</i>	Depth <i>h</i>	
10	6	9	0.8	5.7	6.8	—	—	WBK08S-01(606)
12	8	10	0.9	7.6	7.9	—	—	WBK10S-01(608)
14	10	12	1.15	9.6	9.15	4	6	WBK12S-01(6000)
15	10	12	1.15	9.6	9.15	4	6	WBK12S-01(6000)
16	10	12	1.15	9.6	9.15	4	6	WBK12S-01(6000)
18	10	12	1.15	9.6	9.15	4	6	WBK12S-01(6000)
20	15	13	1.15	14.3	10.15	5	7	WBK15S-01(6002)
25	17	16	1.15	16.2	13.15	6	8	WBK17S-01(6203)
	20	19	1.35	19	15.35	6	8	WBK20S-01(6204)
28	20	19	1.35	19	15.35	6	8	WBK20S-01(6204)
32	25	20	1.35	23.9	16.35	8	10	WBK25S-01W(6205)
36	25	20	1.35	23.9	16.35	8	10	WBK25S-01W(6205)
40	30	22	1.75	28.6	17.75	10	12	(6206)
45	35	23	1.75	33	18.75	12	14	(6207)
50	35	23	1.75	33	18.75	12	14	(6207)

B-1-5 When Placing Orders

To avoid confusion, please use "reference number" or "specification number" when inquiring about desired ball screw specifications.

◇ Reference number:

Alpha-numeric codes are assigned to each ball screw. When placing order, please use this reference number.

◇ Specification number:

Specification factors are identified by alpha-numeric codes. Codes are for easy explanation of your requirements. (If you do not use these numbers, please itemize your requirements.)

B-1-5.1 When Ordering Standard Ball Screws

Find the reference number from the dimension table. Enter the reference number in the "Order Form by Fax" (page B34). Send the fax to your local NSK agency (branch office, sales office, or

your local representative.). The following is the flow chart for ordering standard ball screws.

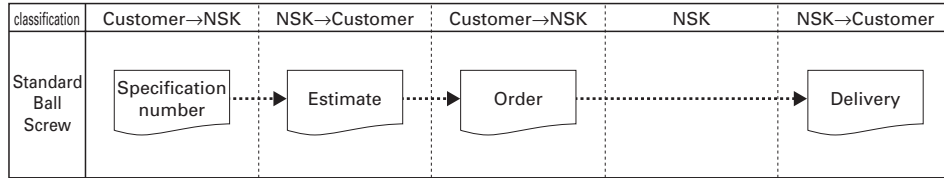

(1) Example of reference number for Standard ball screws Compact FA Series and high-speed SS Series

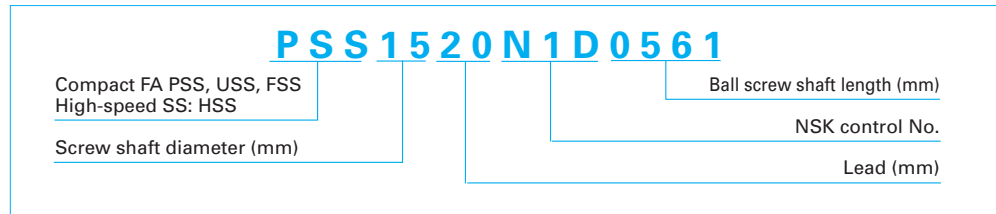

(2) Example of reference number of Standard ball screws

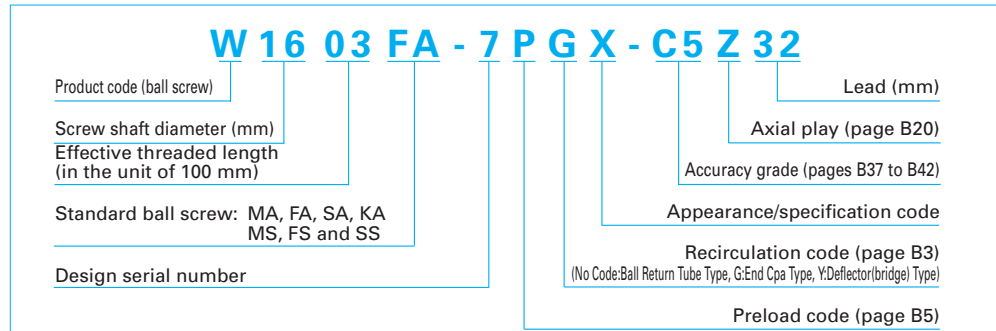

(3) Example of reference number of ball screws for transfer equipment with finished shaft end and blank shaft end

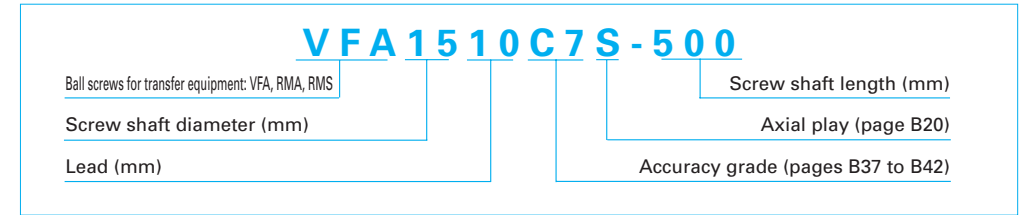

(4) Example of reference number of R series ball screws for transfer equipment

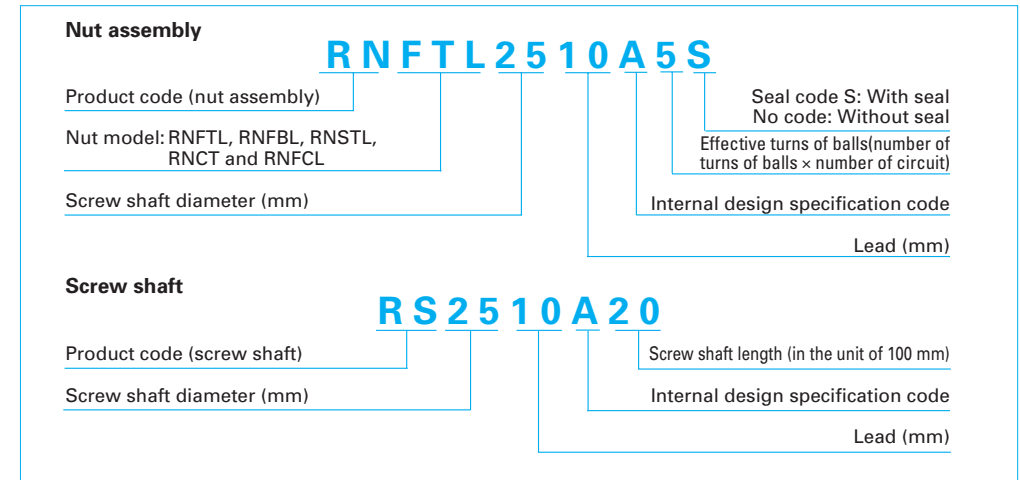

B-1-5.2 When Ordering Made-to-Order Ball Screws

If you would like to discuss technical points regarding specifications, use the NSK ball screw technical data sheet as an aid (page B36). For high-load drive ball screws, use the technical

sheet on page B531 for NSK high-load drive ball screw. The following is the flow chart for ordering made-to-order ball screws.

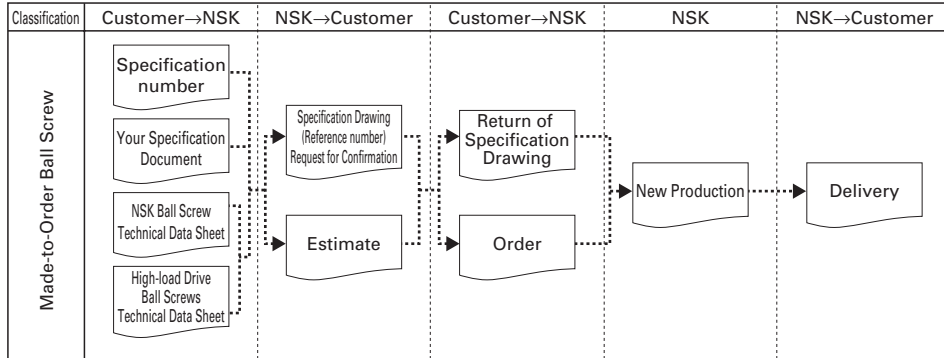

(1) Example of specification number of made-to-order ball screw

DFT 5010-5 L C3Z-850/1230

Nut model: DFT
 Screw shaft diameter (mm): 50
 Lead (mm): 10
 Effective turns of balls (number of turns of balls × number of circuit): 5
 Direction of turn: No code, right; L, left
 Screw shaft length (mm): 850
 Threaded length (mm): 1230
 Axial play (page B20): C3
 Accuracy grade (page B37 to B42): Z

(2) Example of reference number of made-to-order ball screw

W5012-26LD-C1Z10

Product code (Ball Screw): W5012
 Screw shaft diameter (mm): 50
 Effective threaded length (in the unit of 100 mm): 12
 Design serial number: LD
 Direction of turn: No code, right; L, left
 Lead (mm): 26
 Axial play (page B20): C1
 Accuracy grade (page B37 to B42): Z
 Ball screw specification/appearance: 10

Fax Order Form

(Make copies for future orders)

(1) Standard ball screw

Company name : _____ Date: Day Month Year

Address : _____ Telephone : _____

Name of person in charge : _____ Section : _____

Product name	Specification number	Quantity	Desired delivery date
Precision ball screw			
R Series ball screw Nut			
R Series ball screw Screw shaft			
Support unit			
Lock nut			
Grease unit			

Describe the shaft end configuration if processing is required (blank shaft end ball screw). In this case, specify which ball screw in the above list the shaft end shall be processed. Refer to pages B27 to B30 for shaft end configuration. These pages also show the reference number for support units.

Drive side

Opposite of drive side

NSK Ball Screw Technical Data Sheet (example)

(2) Made-to-order ball screw

Company name _____ Date: Day Month Year _____
 Address _____ Telephone _____
 Person in charge _____ Section _____
 Machine which uses the ball screw Machining center Model MC- Application Table left/right movement (X axis)
 Drawing/rough sketch attached? Yes No

Use conditions

Maximum load	9 000 N	20 min ⁻¹	15 %	Operating conditions	Shaft rotation - Moving nut (Normal operation)
Load in normal use	4 000 N	360 min ⁻¹	60 %		Nut rotation - Moving shaft Back drive operation
Minimum load	2 000 N	1 000 min ⁻¹	25 %		Nut rotation - Moving nut Nut rotation - Moving shaft Oscillation
				Degree of vibration shock	Normal
Maximum rotational speed	1 000 min ⁻¹			Required life	20 000 h
Lubricant	Grease/oil (Brand name: <u>NSK GRS AS2</u>) Maker: _____			Motor in use	Company A, Model 1
Seal	Yes	No		Control system	Company B, Model 2 (resolution: 1µm)
Support bearing	Drive side <u>35TAC62DF</u>		Opposite to drive side <u>35TAC62DF</u>		
Guide way	Rolling () Sliding (<u>RA451500GM2-P4Z3-II</u>)				
Environment	Temperature (Normal temperature in degrees Celsius)	Dust	Humidity	Gas	Liquid (where?) Clean room In vacuum
Schedule for prototype	Day	Month	Year (approx.)	Quantity used	Piece
Date, going in production/Quantity	/Month	/Year	/Lot	per machine	

Specification factors of the ball screw

Screw shaft diameter	50 mm	Direction of turn	right	Accuracy grade	C2	Screw shaft length	880 mm	Preload	3000 N
Lead	10 mm	Effective turns of balls		Axial play	0 mm	Overall shaft length	1 335 mm	Required torque	
Nut model	ZFT5010-10	Flange type	Circular I	Nut orientation		Same as shown in the dimension table		Opposite	

Supplemental explanation/requests

NSK Ball Screw Technical Data Sheet (example)

(2) Made-to-order ball screw

Company name _____ Date: Day Month Year _____
 Address _____ Telephone _____
 Person in charge _____ Section _____
 Machine which uses the ball screw _____ Application _____
 Drawing/rough sketch attached? Yes No

Use conditions

Maximum load	N	min ⁻¹	%	Operating conditions	Shaft rotation - Moving nut Normal operation
Load in normal use	N	min ⁻¹	%		Nut rotation - Moving shaft Back drive operation
Minimum load	N	min ⁻¹	%		Nut rotation - Moving nut Nut rotation - Moving shaft Oscillation
				Degree of vibration shock	
Maximum rotational speed	min ⁻¹			Required life	
Lubricant	Grease/oil (Brand name: _____) Maker: _____			Motor in use	
Seal	Yes	No		Control system	(resolution: _____)
Support bearing	Drive side		Opposite to drive side		
Guide way	Rolling Sliding ()				
Environment	Temperature (Normal temperature in degrees Celsius)	Dust	Humidity	Gas	Liquid (where?) Clean room In vacuum
Schedule for prototype	Day	Month	Year (approx.)	Quantity used	Piece
Date, going in production/Quantity	/Month	/Year	/Lot	per machine	

Specification factors of the ball screw

Screw shaft diameter		Direction of turn		Accuracy grade		Screw shaft length		Preload	
Lead		Effective turns of balls		Axial play		Overall shaft length		Required torque	
Nut model		Flange type		Nut orientation		Same as shown in the dimension table		Opposite	

Supplemental explanation/requests

B-2 Technical Description of Ball Screws

B-2-1 Accuracy

B-2-1.1 Lead Accuracy

The lead accuracy of NSK precision ball screws (C0 to C5 grades) conforms to the four characteristics specified in JIS Standards. These characteristics are expressed by codes ep , v_u , v_{300} , and $v_{2\pi}$.

Fig. 1.1 explains the definition of each characteristic, and shows allowable value of each. Leads are classified into two categories: C system for

positioning; Ct system for transportation. Tables 1.2, 1.3 and 1.4 show tolerance of each characteristic. JIS B1192 sets C type and Cp type standards for positioning ball screws. NSK uses the specification of C type only. JIS B1192 specifies Ct1, 3, and 5 grade. NSK standards are integrated by C type only. Refer to Table 1.2 for C type standard tolerance.

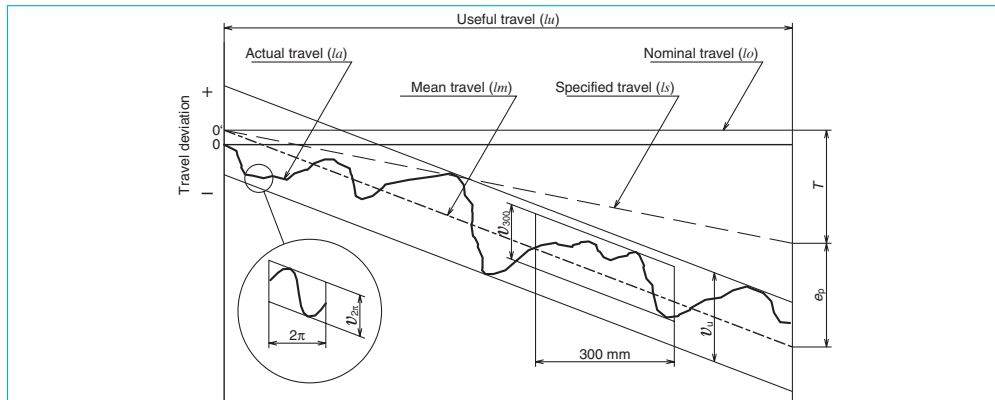

Fig. 1.1 Definition of lead accuracy

Table 1.1 Terminology in lead accuracy

Term	Code	Description	Tolerance
Specified travel	ls	The travel compensates the nominal travel for an elongation caused by an increase of temperature or load.	
Travel compensation	T	Value obtained by subtracting the specified travel from the nominal travel based on the useful travel. The value is to compensate for the errors caused by thermal deformation or deformation by load. This value is determined by tests and experience (see page B39).	
Actual travel	la	Actually measured travel	
Actual mean travel	lm	A straight line that demonstrates the direction of actual travel. This straight line is obtained from the curve that shows actual travel volume by least-squares method or by resembling approximation.	
Tolerance on specified travel	ep	Obtained by subtracting the specified travel from the actual mean travel.	Table 1.2
Travel variation	v_u v_{300} $v_{2\pi}$	Maximum range of the actual travel which is between the two straight lines drawn parallel to the actual mean travel. There are three categories as shown below. <ul style="list-style-type: none"> • Maximum range relative to the effective length of thread. • Maximum range relative to the length of 300 mm anywhere within the effective length of thread. • Maximum range which corresponds to any single rotation (2π rad.) within the effective length of thread. 	Table 1.2 Table 1.3, 1.4 Table 1.3

Table 1.2 Tolerance on specified travel ($\pm ep$) and travel variation (v_u) of the positioning (C type) ball screws

Unit: μm

Effective thread length, mm	Accuracy grade		C0		C1		C2		C3		C5	
	over	or less	$\pm ep$	v_u	$\pm ep$	v_u	$\pm ep$	v_u	$\pm ep$	v_u	$\pm ep$	v_u
	–	100	3	3	3.5	5	5	7	8	8	18	18
	100	200	3.5	3	4.5	5	7	7	10	8	20	18
	200	315	4	3.5	6	5	8	7	12	8	23	18
	315	400	5	3.5	7	5	9	7	13	10	25	20
	400	500	6	4	8	5	10	7	15	10	27	20
	500	630	6	4	9	6	11	8	16	12	30	23
	630	800	7	5	10	7	13	9	18	13	35	25
	800	1 000	8	6	11	8	15	10	21	15	40	27
	1 000	1 250	9	6	13	9	18	11	24	16	46	30
	1 250	1 600	11	7	15	10	21	13	29	18	54	35
	1 600	2 000			18	11	25	15	35	21	65	40
	2 000	2 500			22	13	30	18	41	24	77	46
	2 500	3 150			26	15	36	21	50	29	93	54
	3 150	4 000			30	18	44	25	60	35	115	65
	4 000	5 000					52	30	72	41	140	77
	5 000	6 300					65	36	90	50	170	93
	6 300	8 000							110	60	210	115
	8 000	10 000									260	140
	10 000	12 500									320	170

Table 1.3 Tolerance of travel variation relative to 300 mm (v_{300}) and one revolution ($v_{2\pi}$) of the positioning (C type) ball screws

Unit: μm

Accuracy grade	C0	C1	C2	C3	C5
v_{300}	3.5	5	7	8	18
$v_{2\pi}$	2.5	4	5	6	8

Note: to JIS B1192 standards. Values in other areas are NSK standards.

Table 1.4 Travel variation (v_{300}) relative to 300 mm of the transportation (Ct type) ball screws

Unit: μm

Accuracy grade	Ct7	Ct10
v_{300}	52	210

Note: Tolerance on specified travel (ep) of the transportation (Ct type) ball screws is calculated as follows.

$$ep = \pm \frac{l_u}{300} \times v_{300}$$

l_u : Effective length of the screw thread

Example of specifying lead accuracy

<Use Conditions>

- Nut model: DFT4010-5
- Stroke: 1 000 mm
- Positioning accuracy: ±0.035 mm/1 000 mm

<Calculation>

Obtain required lead accuracy of a ball screw under these conditions.

(1) Calculate the length of the thread

$$\begin{aligned} \text{Stroke} + \text{nut length} + \text{margin} &= 1\ 000 + 193 + 100 \\ &= 1\ 293 \text{ (mm)} \dots \rightarrow 1\ 300 \text{ mm} \end{aligned}$$

(2) Calculate lead accuracy

From **Table 1.2**, obtain the tolerance on specified travel relative to the length of thread (1 300 mm).

C5 ... ±0.054/1 250 – 1 600

C3 ... ±0.029/1 250 – 1 600

(3) Determine lead accuracy

Positioning accuracy is: ±ep < ±0.035/1 000 mm

$$\begin{aligned} \text{Accuracy grade: C3 grade } \pm ep &= 0.029/\text{length of thread (1 300 mm)} \\ v_v &= 0.018 \end{aligned}$$

B-2-1.2 Thermal Expansion and Target Value of Specified Travel

(1) Thermal expansion

Thermal expansion of screw shaft induces the degradation of positioning accuracy of the ball screws. Thermal expansion of a screw shaft is calculated as follows.

$$\Delta L_{\theta} = \rho \cdot \theta \cdot L \text{ (mm)} \dots\dots 1)$$

In this formula:

- ΔL_{θ} : Thermal expansion (mm)
- ρ : Thermal expansion coefficient ($12.0 \times 10^{-6} \text{ } ^\circ\text{C}^{-1}$)
- θ : Average temperature rise of screw shaft (Celsius)
- L : Length of screw shaft (mm)

The above formula indicates that when the temperature rises one degree Celsius, the screw shaft stretches 12 μm per meter. Ball screw generates more heat when it is used at high speed. This causes elongation of the screw shaft. Although the ball screw lead is ground into high precision, an elongated screw shaft due to high temperature rise may not satisfy required highly accurate positioning.

(2) Countermeasures against temperature rise

Countermeasures against temperature rise of the ball screw are:

Hollow shaft cooling or nut cooling ball screws are recommended for operation under high-speed and high-precision conditions.

(a) Suppress heat generation.

- Do not apply excessive preload to the ball screw and support bearing.
- Select appropriate lubricant and use it properly.
- Use higher helix ball screw lead to lower rotational speed.

(b) Use forced cooling.

- Feed liquid coolant into the hollow shaft cooling or nut cooling ball screws. - Refer to the information on hollow shaft ball screw for high accuracy machine tools in the section for application-oriented ball screws (pages B544 to B552).
- Cool screw shaft surface with lubricant oil or air.

(c) Avoid effects of temperature rise on positioning.

- Warm up the machine by high speed until the temperature rise of ball screw shaft saturates, then maintain it properly.
- Set pre-tension. (**Fig. 1.2**)
- Set the negative (minus) target value of specified travel.
- Employ the closed loop control system.

(3) How to determine specified travel

In general, the specified travel of ball screw is the same as the nominal travel. However, the specified lead of ball screw is sometimes set to negative (minus) or positive (plus) to adjust expansion by temperature rise during operation, or the elongation/contraction of the screw shaft by external load. For such occasion, specify travel compensation (T) when ordering the ball screw.

As an example, **Table 1.5** shows the travel compensation (T) for typical NC machine tools.

Table 1.5 Travel compensation (T) of specified travel for typical NC machine tools

Unit: mm		
Type of machine	Axis	Travel compensation (per 1 m)
NC lathes	X	- 0.02 — - 0.05
	Z	- 0.02 — - 0.03
Machining centers	X, Y	- 0.03 — - 0.04
	Z	Differs by structure

(4) How to determine pre-tension force

In order to absorb thermal expansion, pre-tension can be provided to the screw shaft at the time of installation. In this case, the pre-tension is usually equivalent to the expansion brought about by the temperature rise of 2 to 3°C.

Fig. 1.2 shows the bearing support structure in such occasion.

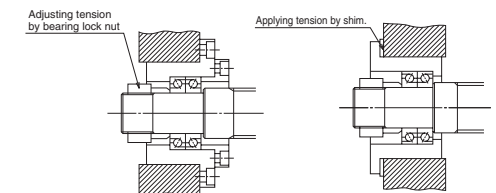

Fig. 1.2 Bearing structure to provide pre-tension

B-2-1.3 Mounting Accuracy and Tolerance of Ball Screws

The accuracy related to mount the ball screws is specified in the following seven characteristics (Fig. 1.3).

The tolerance is indicated in the specification drawing.

Detailed tolerances are specified by JIS B1192. For reference, **Table 1.6** shows standard values of "(7) Total run-out of the screw shaft axis (straightness of the screw shaft)". NSK sets stricter tolerance standards than JIS standards. For accuracy of the ball screw installation, refer to "Installation of Ball Screw (1) Centering of the units" (page B73).

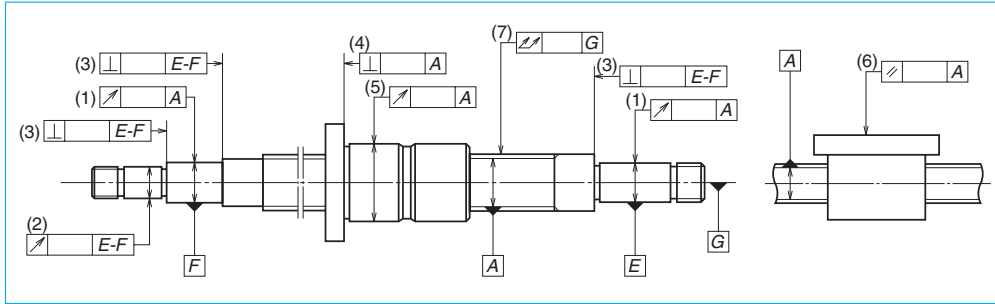

Fig. 1.3 Mounting accuracy of ball screw

- (1) Radial run-out of the support bearing seat relative to the axis of the ball thread of screw shaft.
- (2) Radial run-out of the other shaft ends section relative to the axis of the support bearing seat.
- (3) Perpendicularity of the shoulder of support bearing seat relative to the axis of support bearing seat.
- (4) Perpendicularity of the nut flange surface, or of the nut end datum surface, relative to the axis of screw shaft.
- (5) Eccentricity of the nut outside surface (cylindrical shape) to the axis of screw shaft.
- (6) Parallelism of the nut mounting surface to the screw shaft axis. (in case of flat mounting surface)
- (7) Total run-out of the screw shaft axis.

Table 1.6 Total run-out of the screw shaft axis

Unit: μm

Accuracy grade		C0						C1								
Nominal diameter (mm)	over	–	8	12	20	32	50	–	8	12	20	32	50	80		
	or less	8	12	20	32	50	80	8	12	20	32	50	80	125		
Overall length of screw shaft (mm)	–	125	15	15	15			20	20	15						
	125	200	25	20	20	15		30	25	20						
	200	315	35	25	20	20		40	30	25	20					
	315	400		35	25	20	15		45	40	30	25	20			
	400	500		45	35	25	20			50	40	30	25			
	500	630		50	40	30	20	15		60	45	35	25	20		
	630	800			50	35	25	20			60	40	30	25		
	800	1 000			65	45	30	25			75	55	40	30	25	
	1 000	1 250			85	55	40	30			95	65	45	35	30	
	1 250	1 600			110	70	50	40			130	85	60	45	35	
	1 600	2 000				95	65	45				120	80	55	40	
	2 000	2 500											100	70	50	
	2 500	3 150													130	90
	3 150	4 000														120

Ball Screw

Unit: μm

Accuracy grade		C3						C5											
Nominal diameter (mm)	over	–	8	12	20	32	50	80	–	8	12	20	32	50	80				
	or less	8	12	20	32	50	80	125	8	12	20	32	50	80	125				
Overall length of screw shaft (mm)	–	125	25	25	20				35	35	35								
	125	200	35	35	25	20			50	40	40	35							
	200	315	50	40	30	30			65	55	45	40							
	315	400	60	50	40	35	25		75	65	55	45	35						
	400	500		65	50	40	30			80	60	50	45						
	500	630		70	55	45	35	30			90	75	60	50	40				
	630	800			70	55	40	35				90	70	55	45				
	800	1 000			95	65	50	40	30			120	85	65	50	45			
	1 000	1 250			120	85	60	45	35			150	100	75	60	50			
	1 250	1 600			160	110	75	55	40			190	130	95	70	55			
	1 600	2 000				140	95	70	50				170	120	85	65			
	2 000	2 500					120	85	60					150	110	80			
	2 500	3 150						160	110	75					200	140	95		
	3 150	4 000							220	150	100					260	180	120	
	4 000	5 000								200	130						240	160	
	5 000	6 300																310	210
6 300	8 000																	280	
8 000	10 000																		370

B-2-1.4 Automatic Lead Accuracy Measuring System of NSK

In response to the demand for high precision in production technology, NSK is the first in the world that developed and uses "Lead Accuracy Measuring System (LAMS)." Lead accuracy is measured by the system that employs a laser interferometer measuring instrument and a personal computer.

Fig. 1.4 shows the lead accuracy measuring system. The inspection date of the ball screw is shown in Fig. 1.5. The laser interferometer measures either ball nut travel accuracy or lead accuracy of the ball thread. The data which are input into a computer are processed into four characteristics readings regarding lead accuracy. (See page B37.)

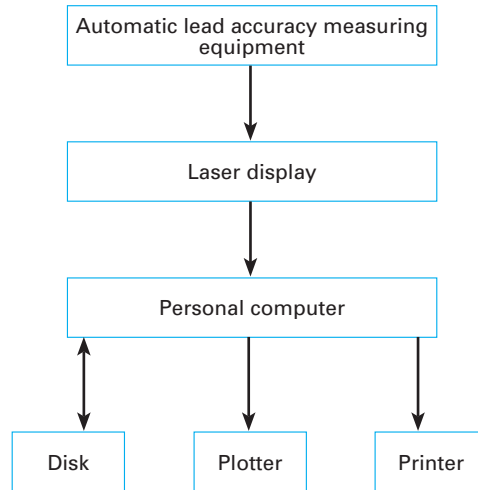

Fig. 1.4 Lead accuracy measuring system

NSK

BALL SCREW INSPECTION DATA

NSK REF NO. _____

CUSTOMER'S PART NO. _____

SERIAL NO. _____

SHAFT NO. _____

MEASURING INSTRUMENT: Laser beam type: automatic
lead measuring instrument.

TEMPERATURE: 20 ± 0.2°C

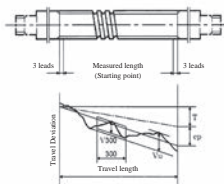

Nominal lead	± 0.01	mm
Specified travel deviation for compensation	± 0.01	mm
Accuracy	Permissible value	Measured result
Mean travel deviation	± 0.01	± 0.01
Variation over the travel length	± 0.01	± 0.01
Variation within 300mm travel	± 0.01	± 0.01
Preload drag torque	None	None
Axial play	± 0.01	± 0.01

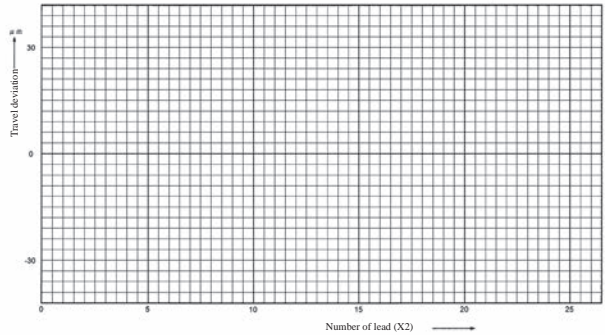

All dimensions are within specifications.

INSPECTOR: _____

DATE: - - -

NSK Ltd. TOKYO, JAPAN

Fig. 1.5 Ball screw inspection data

B-2-2 Static Load Limitation

Ball screws, based on their function, will generally receive axial load only. Ball screw shafts in general are long, so it is necessary to consider 3 items below:

- Buckling load of the screw shaft
- Yielding of the screw shaft by tensional or compressive stress
- Permanent deformation at the ball contact points

$$I = \frac{\pi}{64} d_r^4 \quad (\text{mm}^4) \dots\dots 3$$

d_r : Screw shaft root diameter (mm) (See the dimension table.)

L : Unsupported length (mm) (See Figs. 4.1 and 4.2 'Supporting conditions of screw shaft and nut' on page B51.)

m, N : Factors determined by the supporting condition of the ball screw shaft

B-2-2.1 Buckling Load

It is necessary to calculate whether the ball screw shaft is safe against buckling.

Buckling load, i.e. permissible compressive load "P" to axial direction, is calculated as follows.

$$P = \alpha \times \frac{N \cdot \pi^2 \cdot E \cdot I}{L^2} = m \frac{d_r^4}{L^2} \times 10^4 \quad (\text{N}) \dots\dots 2$$

In this formula:

α : Safety factor ($\alpha = 0.5$)

E : Elastic modulus ($E = 2.06 \times 10^5$ MPa)

I : Moment of inertia

Table 2.1 Factors of buckling load

Supporting condition	m	N
Fixed - Fixed support	19.9	4
Fixed - Simple support	10.0	2
Fixed support - Free	1.2	0.25
Simple - Simple support	5.0	1

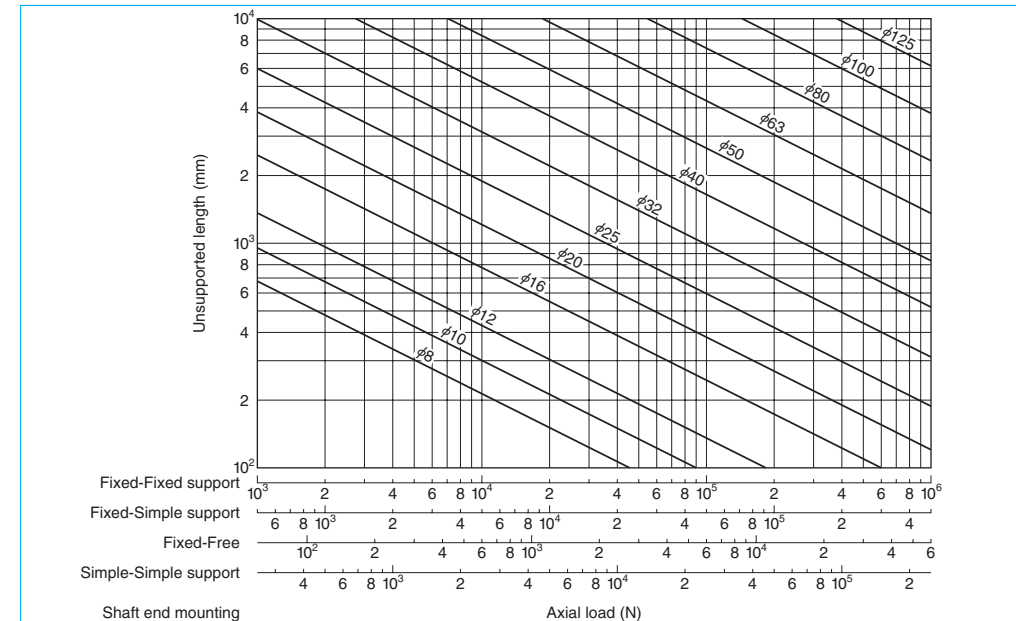

Fig. 2.1 Buckling load

<<Calculation example of buckling load>>

Calculate buckling load under the conditions in Fig. 2.2.

<Use conditions>

Nut model: DFT4010-5

Supporting condition is Fixed - Fixed support (From the supporting condition (ii) in Fig. 4.1 'Supporting conditions of screw shaft and nut' on page B51.)

Unsupported length $L = 2\,000$ mm

Screw shaft root diameter $d_r = 34.4$ mm (From the dimension table)

<Calculation>

Support condition is Fixed - Fixed support, from Table 2.1 on page B44

$$N = 4$$

$$m = 19.9$$

By formula 2) on page B44

$$P = m \frac{d_r^4}{L^2} \cdot 10^4 = 19.9 \times \frac{34.4^4}{2\,000^2} \times 10^4 = 69\,667 \text{ (N)}$$

Therefore,

$$\text{Permissible buckling load } P = 69\,600 \text{ N}$$

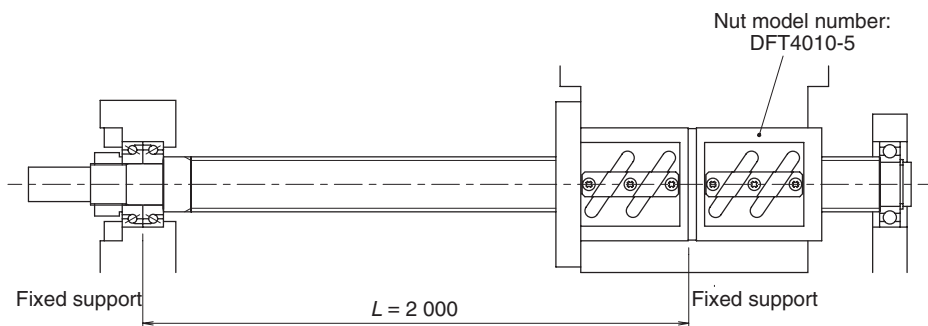

Fig. 2.2 Calculation example of buckling load

B-2-2.2 Yield by Tensional/Compressive Stress

It is necessary to consider permissible load in regards to the yield stress.

Permissible load "P" by tensional or compressive stress to screw shaft is

$$P = \sigma \cdot A = 1.15 d_r^2 \times 10^2 \text{ (N)} \quad \dots 4)$$

In this formula:

σ : Allowable stress (= 147 MPa)

A: Cross section area of a screw shaft using root diameter (mm²)

$$A = \frac{\pi}{4} \cdot d_r^2 \text{ (mm}^2\text{)} \quad \dots 5)$$

d_r : Screw shaft root diameter (mm)

<<Calculation example of yield load>>

Obtain load in respect to the allowable stress under the conditions in Fig. 2.2.

<Use conditions>

Nut model: DFT4010-5

Screw shaft root diameter $d_r = 34.4$ (mm)
(From the dimension table)

<Calculation>

By formula 4)

$$P = 1.15 d_r^2 \times 10^2 = 1.15 \times 34.4^2 \times 10^2 = 136\,086 \text{ (N)}$$

Therefore,

$$\text{Permissible load } P = 136\,000 \text{ N}$$

B-2-2.3 Permanent Deformation at the Ball Contact Point

Exposed to an excessively heavy load in axial direction, the balls are squashed, and the ball rolling surface is dented. The deformations on these points do not perfectly restore to original shape after the load is removed. They are permanently disfigured. It is necessary to determine the limitation of this disfigurement to containing it within a certain range.

(1) Basic static load rating C_{0a}

Basic static load rating C_{0a} is a load to axial direction that results in the combined permanent deformation equal to 0.01% of the ball diameter at the contact points of ball and ball grooves of the screw shaft and nut.

(2) Calculation of permissible load by C_{0a}

P_0 (allowable axial direction load to limit the permanent deformation) is calculated using C_{0a} .

$$P_0 = \frac{C_{0a}}{f_s} \text{ (N)} \quad \dots 6)$$

In this formula, f_s : Static permissible load factor

Table 2.2 Static permissible load factor

At time of normal operation	1 - 2
With vibration impact	1.5 - 3

<<Calculation example of the maximum allowable load>>

Obtain the maximum allowable load to the ball groove section under conditions in Fig. 2.2.

<Use conditions>

Nut model: DFT4010-5

Basic static load rating $C_{0a} = 137\,000$ (N)
(From the dimension table)

Static permissible load factor $f_s = 2$
(normal operation, no vibration impact)

<Calculation>

By formula 6), the maximum allowable load of the ball groove section

$$P_0 = \frac{C_{0a}}{f_s} = \frac{137\,000}{2} = 68\,500 \text{ (N)}$$

B-2-3 Permissible Rotational Speed

Permissible rotational speed is determined by the feeding speed and ball screw lead. When selecting a ball screw, it is important to know the permissible rotational speed.

It is necessary to calculate two items below, and whichever smaller is the permissible rotational speed.

The lower of the following two factors, d·n and critical speed, will determine the overall permissible rotational speed of the ball screw.

- Critical speed which is the resonance vibration of the shaft.

- d·n value which is involved in damaging the ball recirculation components.

* Please consult NSK if the maximum rotational speed exceeds the criteria of maximum rotational speed on page B50, even both the critical speed of screw shaft rotation and the d·n value are in range of the allowable limit.

B-2-3.1 Critical Speed of the Screw Shaft

Calculate the critical speed which is the matching value of the ball screw rotational speed and the natural frequency of the screw shaft. The 80% of the critical speed is defined as the permissible rotational speed.

Calculate the critical speed of the screw shaft whether you use shaft rotation or nut rotation. Critical speed varies by the nut traveling position. Please consult NSK for detailed calculation.

If using a ball screw exceeding the critical speed, it is necessary to increase the natural frequency by using an intermediate support, etc. If using with nut rotation, it is possible to operate exceeding critical speed by installing a vibration energy absorbing system (optional, vibration control damper: patented by NSK) to the screw shaft. (Refer to "Nut rotatable drive ND Series" on page B553.)

Calculate the permissible rotational speed based on critical speed n_c as follows, taking in account "B-2-4 Supporting Conditions for Calculation of Buckling Load and Critical Speed" on page B51.

Fig. 3.1 shows the permissible rotational speeds against critical speed for each shaft diameter.

$$n_c = \alpha \times \frac{60\lambda^2}{2\pi L^2} \sqrt{\frac{E \cdot I \cdot g}{\gamma \cdot A}} \quad \dots 7)$$

$$= f \frac{d_r}{L^2} \times 10^7 \text{ (min}^{-1}\text{)} \quad \dots 7)$$

In this formula:

α : Safety factor ($\alpha = 0.8$)

E : Elastic modulus ($E = 2.06 \times 10^5$ MPa)

I : Moment of inertia of area of screw shaft

$$I = \frac{\pi}{64} d_r^4 \text{ (mm}^4\text{)} \quad \dots 3)$$

d_r : Screw shaft root diameter (mm) (See the dimension table.)

g : Acceleration of gravity ($= 9.8 \times 10^3$ mm/s²)

γ : Specific weight ($\gamma = 7.65 \times 10^5$ N/mm³)

A : Cross section area of the screw shaft root diameter (mm²)

$$A = \frac{\pi}{4} \times d_r^2 \text{ (mm}^2\text{)} \quad \dots 5)$$

L : Unsupported length (mm) (See Figs. 4.1, and 4.2 "Supporting conditions of screw shaft and ball nut" on page B51)

f, λ : Factors determined by the supporting condition

Table 3.1 Coefficients of critical speed

Supporting condition	f	λ
Fixed - Simple support	15.1	3.927
Fixed - Fixed support	21.9	4.730
Fixed support - Free	3.4	1.875
Simple - Simple support	9.7	π

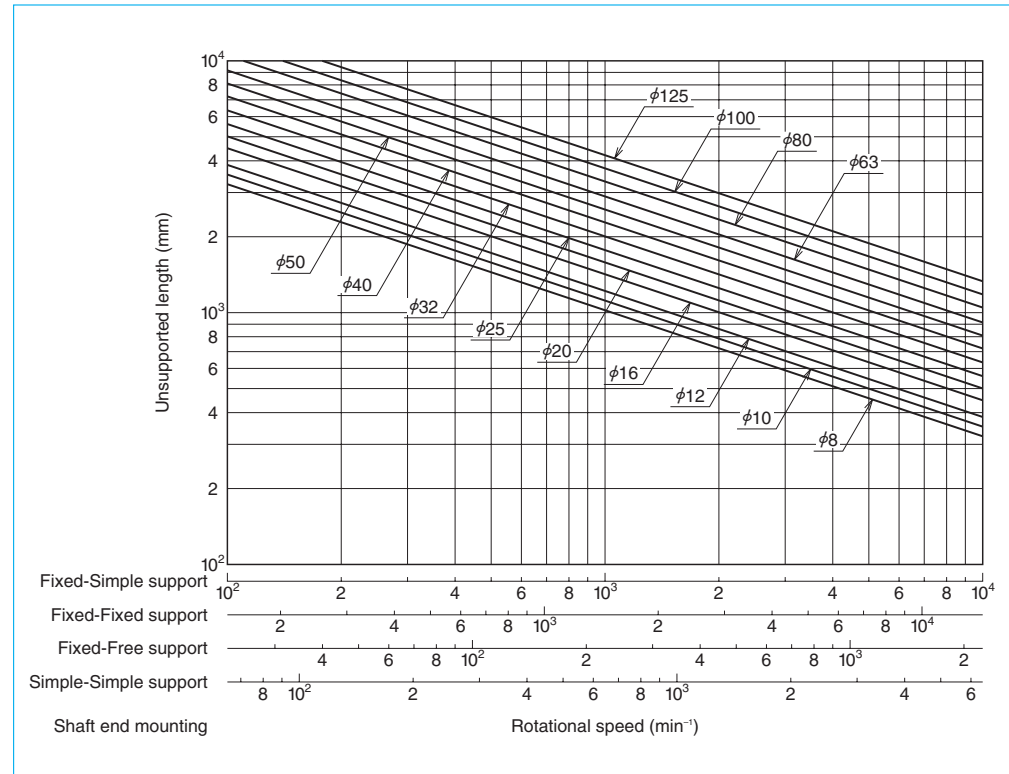

Fig. 3.1 Permissible rotational speeds vs. critical speeds

<<Calculation example of permissible rotational speed to the critical speed>>
 Calculate the permissible rotational speed to the critical speed under conditions in Fig. 3.2.

<Use conditions>

Nut model: DFT4010-5

Supporting condition is Fixed - Simple support (From the supporting condition (ii) in Fig. 4.1 "Supporting conditions of screw shaft and ball nut" on page B51.)

Unsupported length $L = 2\,000$ mm

Screw shaft root diameter $d_r = 34.4$ mm (from the dimension table)

<Calculation>

Supporting condition is Fixed-Simple support, from Table 3.1 on page B47

$$\lambda = 3.927$$

$$f = 15.1$$

By formula 7) on page B47, permissible rotational speed to critical speed is

$$n_c = f \frac{d_r}{L^2} \times 10^7 = 15.1 \times \frac{34.4}{2\,000^2} \times 10^7 = 1\,298.6 \text{ (min}^{-1}\text{)}$$

$$n_c = 1\,290 \text{ min}^{-1} \text{ or under}$$

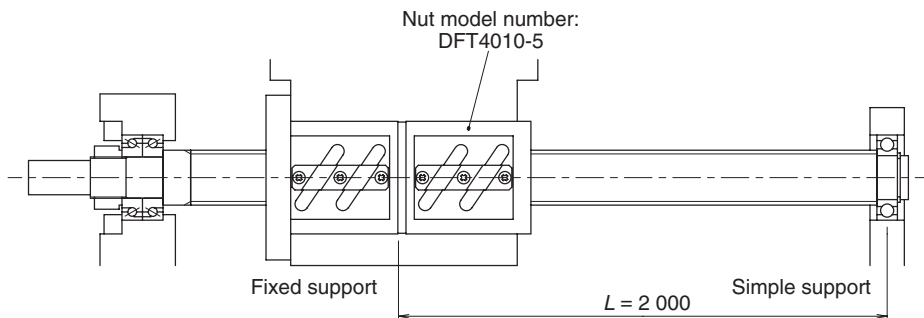

Fig. 3.2 Calculation example of permissible rotational speed to the critical speed

B-2-3.2 d-n Value

An increase of ball orbital speed increases the collision impact of balls to ball recirculation parts, and thus resulting in damage to them. For this reason, the permissible rotational speed is also limited by the d-n value (d, shaft diameter in millimeters; n, rotational speed per minutes).

Table 3.2 shows the allowable d-n value and the maximum rotational speed of ball screws.

Notes: 1. Special measure must be taken for high-speed specification products. Please consult NSK.

2. Please consult NSK if the maximum rotational speed or the d-n value exceed the values on the table below, even both the critical speed of screw shaft and the d-n value are in ranges of the allowable limit.

Table 3.2 Criteria of allowable d-n value and maximum rotational speed

Ball screw recirculation system, Series/Type		Allowable d-n value		Criterion of permissible rotational speed [min ⁻¹]
		Standard	High-speed	
Standard ball screw	Ball screw for transfer equipment R series	50 000 or less	–	3 000
	End-deflector type	180 000 or less	–	5 000
Standard nut ball screws	Return tube type	70 000 or less	100 000 or less	3 000
	Deflector(bridge) type	84 000 or less	100 000 or less	3 000
	End cap type	80 000 or less	100 000 or less	3 000
Application-oriented ball screws	HMD type for high-speed machine tools	160 000 or less	–	4 000
	HMS type for high-speed machine tools	160 000 or less	–	5 000
	HMC type for high-speed machine tools	100 000 or less, 135 000 or less ^{*1}	–	3 750
	BSL type for miniature lathes	(180 000 or less)	–	4 000
	HTF-SRC type for high-load drives	140 000 or less, 160 000 or less ^{*1}	–	3 225
	HTF-SRD type for high-load drives	120 000 or less	–	2 400
	HTF type for high-load drives	50 000 or less, 70 000 or less ^{*1}	100 000 or less	3 125
	VSS type for contaminated environment	150 000 or less	–	3 000
	ND series nut-rotatable ball screws	70 000 or less	100 000 or less	3 000
	Σ series for robots	70 000 or less	–	3 000
	R series for transfer equipment	50 000 or less	–	3 000

*1) Please refer to the explanation of each ball screw for which two allowable d-n values are listed

- HMC type for high-speed machine tools: page B503
- HTF-SRC type for high-load drives: page B513
- HTF type for high-load drives: page B521

B-2-4 Supporting Conditions for Calculation of Buckling Load and Critical Speed

Figs. 4.1 and 4.2 are typical conditions in supporting ball screws. Use them as reference to calculate the buckling load and the critical speed.

Please consult NSK if it is necessary to scrutinize calculation due to use conditions, or if boundary conditions are not clear due to special installation.

[How to read the tables]

Example ii: A buckling load generates between the nut and the left bearings, indicating that the critical speed appears between the nut and the right bearing. Therefore, set L at the maximum stroke for each side. Calculate by applying support bearing conditions.

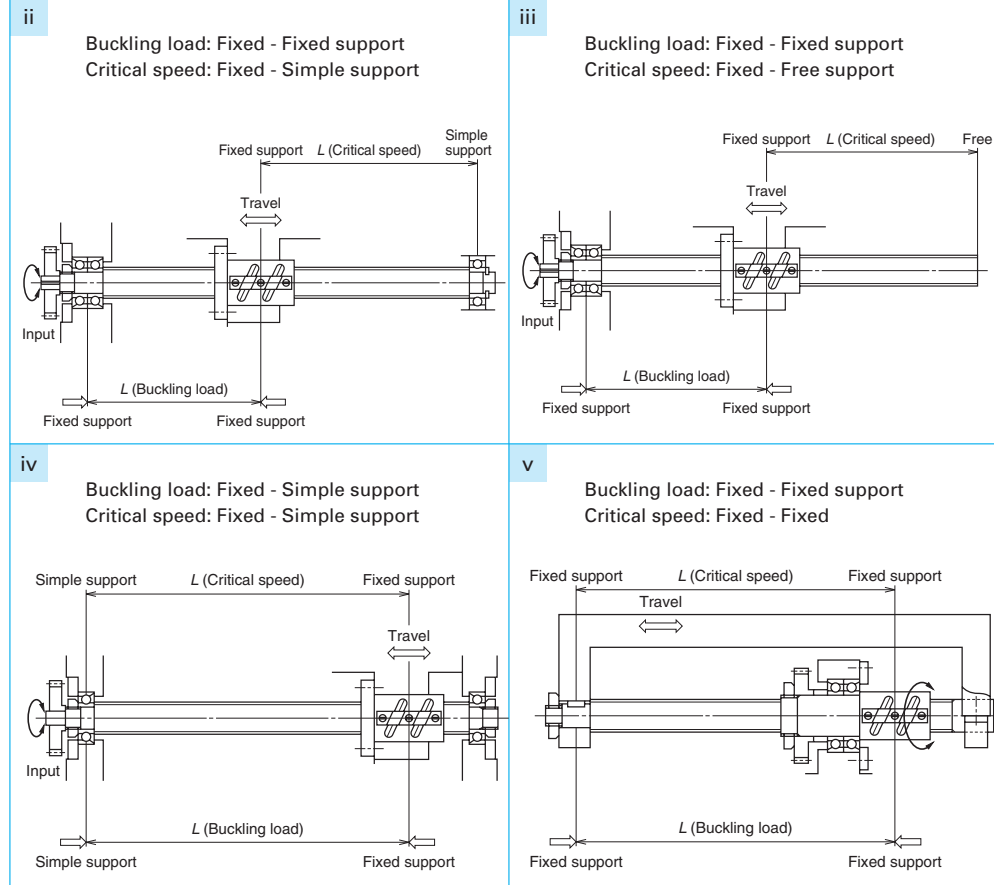

Fig. 4.1 Supporting conditions for screw shaft and ball nut

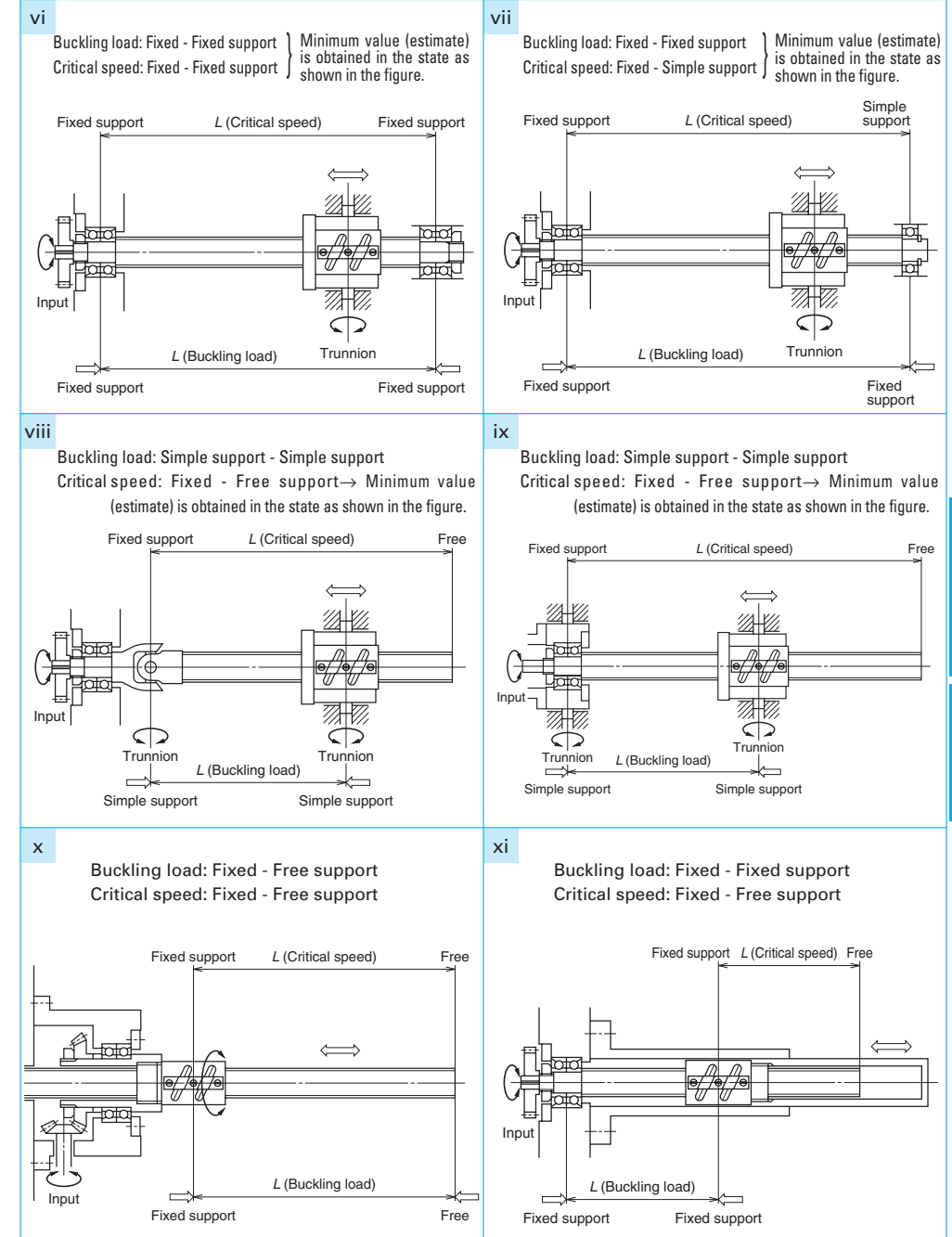

Fig. 4.2 Supporting conditions of screw shaft and ball nut

B-2-5 Life (Dynamic Load Limitation)

B-2-5.1 Life of Ball Screw

Although used in appropriate conditions and is ideally designed, the ball screw deteriorates after a certain operation period, and eventually becomes unusable. The period in this situation is the life of the ball screw. There are two life categories, "fatigue life" caused by flaking, and "life of accuracy" caused by deterioration in precision because of wear.

B-2-5.2 Fatigue Life

Fatigue life of a ball screw can be estimated by basic dynamic load rating (C_a) as is for the rolling bearings.

(1) Basic dynamic load rating C_a

Basic dynamic load rating is the axial load that allows a 90% of the group of the same ball screws to rotate 1 million times (10^6 rev) under the same condition without causing flaking by rolling contact fatigue.

(2) Fatigue life calculation

Fatigue life is defined as a total rotation number in general. It is sometimes indicated by total rolling hours or total running distance. Fatigue life is obtained by the following formula.

$$L = \left(\frac{C_a}{F_a \cdot f_w} \right)^3 \cdot 10^6 \quad \dots 8)$$

$$L_t = \frac{L}{60n} \quad \dots 9)$$

$$L_s = \frac{L \cdot l}{10^6} \quad \dots 10)$$

In this formula:

L : Rating fatigue life (rev)

L_t : Life in hours (h)

L_s : Life by running distance (km)

C_a : Basic dynamic load rating (N)

F_a : Axial load (N)

n : Rotational speed (min^{-1})

l : Lead (mm)

f_w : Load factor (Coefficient by operating condition)

Load factor f_w for operating conditions is shown in **Table 5.1**.

Table 5.1 Load coefficient f_w

Smooth operation without impact	1.0 – 1.2
Normal operation	1.2 – 1.5
Operation associated with impact or vibration	1.5 – 3.0

Setting too long fatigue life requires larger ball screw, and is not economical. Below are the general target values of operating life for machines. (reference)

Table 5.2 General target values of fatigue life

Machine tools	20 000 hours
Industrial machines	10 000 hours
Automatic control system	15 000 hours
Measuring equipment	15 000 hours

(3) Mean load

If the axial load often varies, calculate life by obtaining the mean load, which gives the equivalent fatigue life under this varying load conditions.

(a) When the load and the rotational speed shift stepwise Obtain the mean load F_m by the formula below.

Obtain mean rotational speed N_m by the formula below as **Table 5.3** and **Fig. 5.1**.

$$F_m = \left(\frac{F_1^3 \cdot n_1 \cdot t_1 + F_2^3 \cdot n_2 \cdot t_2 + \dots + F_n^3 \cdot n_n \cdot t_n}{n_1 \cdot t_1 + n_2 \cdot t_2 + \dots + n_n \cdot t_n} \right)^{\frac{1}{3}} \quad \dots 11)$$

$$N_m = \frac{n_1 \cdot t_1 + n_2 \cdot t_2 + \dots + n_n \cdot t_n}{t_1 + t_2 + \dots + t_n} \quad \dots 12)$$

Table 5.3 Stepwise operation condition

Axial load (N)	Rotational speed (min^{-1})	Hours of use, or ratio of hours of use
F_1	n_1	t_1
F_2	n_2	t_2
:	:	:
F_n	n_n	t_n

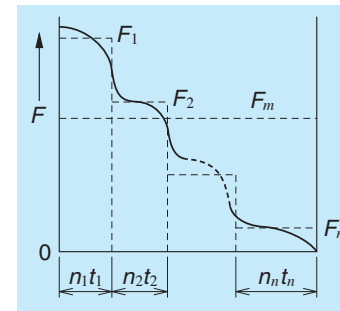

Fig. 5.1 Stepwise load variation

(b) When the rotational speed is constant, and the load changes linearly, obtain approximate value of the mean load F_m by the formula below.

$$F_m = \frac{1}{3} (F_{min} + 2F_{max}) \quad \dots 13)$$

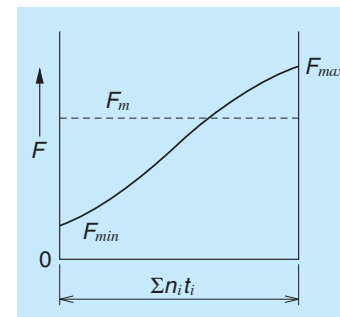

Fig. 5.2 Linear load change

(c) When the rotational speed is constant, and the load changes in a sinusoidal pattern, obtain approximate value of the mean load F_m by the formula below.

When the sine curve is Fig. (a)
 $F_m \doteq 0.65 F_{max} \quad \dots 14)$

When the sine curve is Fig. (b)
 $F_m \doteq 0.75 F_{max} \quad \dots 15)$

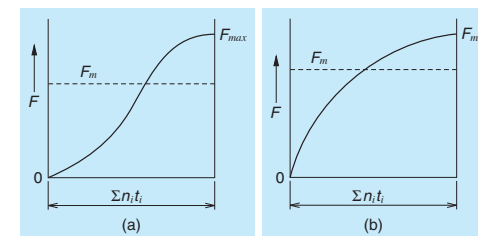

Fig. 5.3 Load changes in sinusoidal pattern

(4) Affect of mounting misalignment

If moment load or radial load is applied to the ball screw, it adversely affects ball screw function, and shortens life. Watch for eccentric load that induces moment or radial load.

Fig. 5.4 shows a calculation example of fatigue life when moment load is applied to the ball screw. In this figure, the value of the rigidity of mounting ball screw sections (screw shaft, support bearing, guide, etc.) is set at infinity. In actual use, deformation is absorbing the moment load in various areas, and the moment load that generates between the screw shaft and nut is abated.

In general, the following values are recommended as control values for precision grade.

Misalignment in inclination $\dots 1/2\ 000$ or less
 Eccentricity $\dots 20\ \mu\text{m}$ or less

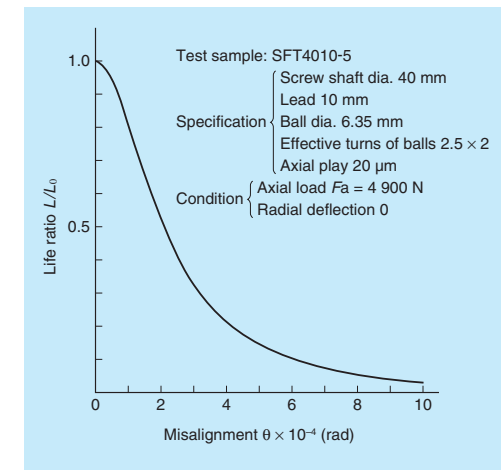

Fig. 5.4 Affects of misalignment

(5) Effects of heavy load and short stroke

If the ball screw is used under heavy load and short strokes, such as for the drive of plastic injection molding machine and of press machines, the fatigue life may become significantly shorter than the rated fatigue life which is calculated in B-2-5.2.

This decreased life occurs because the heavy load generates large stress (surface pressure) in the contact points of balls and ball grooves of the screw shaft and the nut, adversely affecting the life.

The axial load F_{amax}^{*1} during operation and the size of strokes, which affect fatigue life, can be obtained by the following formula. In such case, the life calculation should take into account the size of the surface pressure as well as the size of the stroke. Please consult with NSK.

$$F_{amax} \geq 0.10C_{0a} \dots 16)$$

$$S \leq 4$$

In this formula:

F_{amax} : Maximum load to axial direction during drive (N)

C_{0a} : Basic static load rating (N)

S : Stroke (rev)

$$S = \frac{L_s}{l}$$

L_s : Stroke distance (mm)

l : Lead (mm)

*1) Axial load : The load is applied to the axial direction when screw shaft and the nut of ball screw are rotating relatively each other. The rotational speed is irrelevant.

B-2-5.3 Ball Screw and Hardness

Table 5.4 indicates the hardness of NSK standard ball screw.

Table 5.4 Ball screw materials and their hardness

Component	Heat treatment method	Hardness (HRC)
Screw shaft	Carburizing	58 or over
	Induction hardening	58 or over
Nut	Carburizing	58 or over

Note: NSK manufactures special material ball screws for special environments (stainless steel: SUS440C, SUS630). NSK also furnishes protective surface treatment (refer to page D5). Please consult NSK for such request.

B-2-5.4 Wear Life

Wear of materials, as is the case for other mechanical components, is significantly affected by use conditions, lubrication conditions and other factors. It is difficult to estimate its volume, and measuring requires various tests and field data.

NSK has the data of wear accumulated through abundant experience. Please contact NSK for inquiry pertaining to the wear.

B-2-6 Preload and Rigidity

B-2-6.1 Elastic Deformation of Preloaded Ball Screw

(1) Position preload (D, Z, and P preload)

The concept of double nut preload ball screw is shown in Fig. 6.1.

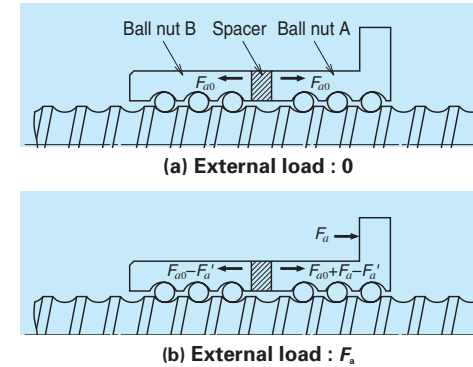

Fig. 6.1 Position preload (double-nut)

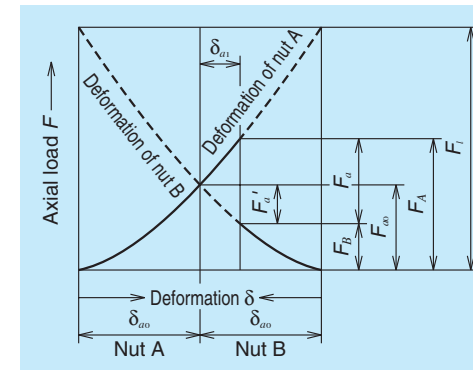

Fig. 6.2 Deformation of A and B nut (position preload)

Elastic deformation of Nut A and B is already given at time of assembly by the amount of δ_{a0} by preload F_{a0} . When the external load F_a is added to Nut A, the elastic deformation δ_a and δ_b of each Nut A and B change as shown in Fig. 6.2,

$$\delta_a = \delta_{a0} + \delta_{a1} \quad \delta_b = \delta_{a0} - \delta_{a1}$$

At this time, the load to each Nut A and B are:

$$F_A = F_{a0} + F_a - F_a'$$

$$F_B = F_{a0} - F_a'$$

It shows that the load applied to Nut A is

affected by Nut B and reduced by the amount of F_a' . Thereby, the elastic deformation of Nut A becomes smaller. This effect continues until the elastic deformation by the external load becomes δ_{a0} , and the preload by Nut B disappears.

Assuming that the load when the preload is absorbed is F_l , the relationship between the axial load and the elastic deformation is as follows (refer to Fig. 6.2).

$$\delta_{a0} = K \cdot F_{a0}^{2/3} \quad 2\delta_{a0} = K \cdot F_l^{2/3}$$

(K: Invariable number)

$$\left[\frac{F_l}{F_{a0}} \right]^{2/3} = \frac{2\delta_{a0}}{\delta_{a0}} = 2$$

$$F_l = 2^{3/2} \times F_{a0} \doteq 3F_{a0}$$

For this reason, the preload should be about 1/3 of the maximum axial load. However, please note that if the preload of about 1/3 of the maximum axial load exceeds 10% of C_a , which is the criterion of the maximum preload, the ball screw may adversely increase heat generation and / or may shortens its lifetime.

Fig. 6.3 shows two types of elastic deformation curves: one is by the ball screw with preload, the other without preload. When an axial load which is about three times as large as the preload is applied, the deformation of the preloaded ball screw is 1/2 of the deformation of the ball screw without preload.

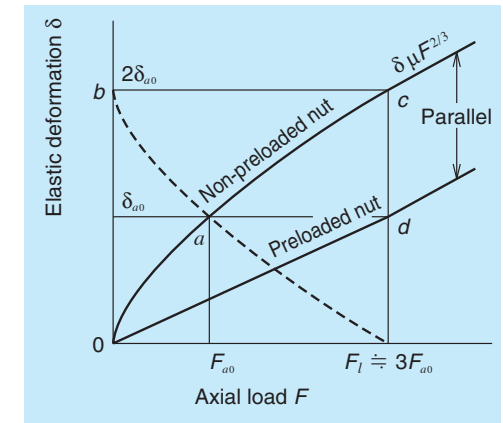

Fig. 6.3 Deformation of preloaded ball nut (position preload)

(2) Constant pressure preload (J preload: preloaded by spring)

Fig. 6.5 shows an elastic deformation of a ball screw which is preloaded with "constant pressure." The rigidity of the preload spring is sufficiently smaller than the nut rigidity. Therefore, the deformation of the spring becomes nearly parallel to the abscissa axis. For this reason, the elastic deformation by the preload with constant pressure changes along the deformation curve by Nut A. In order to take advantage of the characteristics of the preload with constant pressure, the major external load should be applied in the directions shown by an arrow in Fig. 6.4.

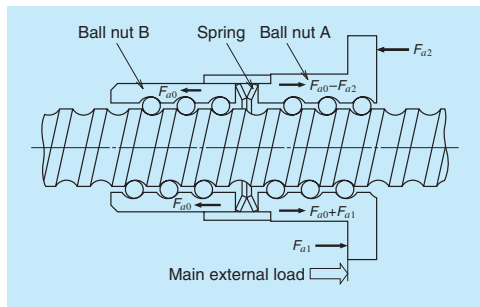

Fig. 6.4 Constant pressure preload (double nut)

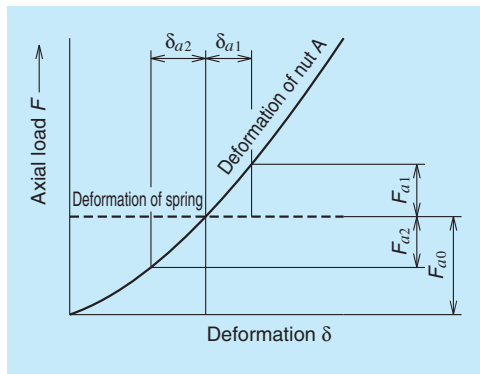

Fig. 6.5 Deformation curve of constant pressure preloaded nut

B-2-6.2 Rigidity of the Feed Screw System

A low rigidity around the feed screw mounting area causes lost motion. To improve the positioning accuracy of precision machines such as NC machine tools, it requires a good balance in axial rigidities of composing parts of the feed screw system. Also should examine torsional rigidities of the feed screw system.

(1) Axial rigidity of the feed screw system K_T

Elastic deformation and rigidity of the feed screw system can be obtained by the following formula.

$$\delta = \frac{F_s}{K_T} \dots\dots\dots 17)$$

$$\frac{1}{K_T} = \frac{1}{K_S} + \frac{1}{K_N} + \frac{1}{K_B} + \frac{1}{K_H} \dots\dots\dots 18)$$

In this formula:

δ : Volume of axial elastic deformation of the feed screw system (μm)

- F_s : Axial load to the feed screw system (N)
- K_T : Axial rigidity of the feed system (N/ μm)
- K_S : Axial rigidity of the screw shaft (N/ μm)
- K_N : Axial rigidity of the nut (N/ μm)
- K_B : Axial rigidity of the support bearing (N/ μm)
- K_H : Axial rigidity of the nut and bearing mounting section (N/ μm)

(2) Axial rigidity of the screw shaft: K_S

(a) In case of: Fixed support - Free (axial direction)

$$K_S = \frac{A \cdot E}{x} \times 10^{-3} \dots\dots\dots 19)$$

In this formula:

- K_S : Axial rigidity of the screw shaft (N/ μm)
- A : Cross section area of the screw shaft (mm^2)
- $A = \frac{\pi}{4} d_r^2$
- d_r : Screw shaft root diameter (mm)
- E : Elastic modulus ($E = 2.06 \times 10^5 \text{ MPa}$)
- x : Distance between points of load application (mm)

(b) In case of: Fixed – Fixed support (axial direction)

$$K_S = \frac{A \cdot E \cdot L}{x(L-x)} \times 10^{-3} \dots\dots\dots 20)$$

In this formula:

- K_S : Axial rigidity of the screw shaft (N/ μm)
- L : Unsupported length (mm)
- x : Axial deformation is maximum at position $x = L/2$.

Axial rigidity of the screw shaft can be obtained by the following formula.

$$K_S = \frac{4A \cdot E}{L} \times 10^{-3} \dots\dots\dots 21)$$

<<Calculation example of axial rigidity (1)>>

Obtain axial rigidity of the screw shaft under the condition in Fig. 6.6.

<Use conditions>

- Nut model: DFT4010-5
- From Fig. 6.6: Supporting condition ; Fixed support --Free (axial direction)
- Distance between points of load application $x = 1\,200 \text{ mm}$
- Screw shaft root diameter (from the dimension table) $d_r = 34.4 \text{ mm}$

<Calculation>

By formula 19), axial rigidity K_S is :

$$A = \frac{\pi}{4} d_r^2 = \frac{3.14}{4} \times 34.4^2 = 929.4 \text{ (mm}^2\text{)}$$

$$K_S = \frac{A \cdot E}{x} \times 10^{-3} = \frac{929.4 \times 2.06 \times 10^5}{1\,200} \times 10^{-3} = 159 \text{ (N/}\mu\text{m)}$$

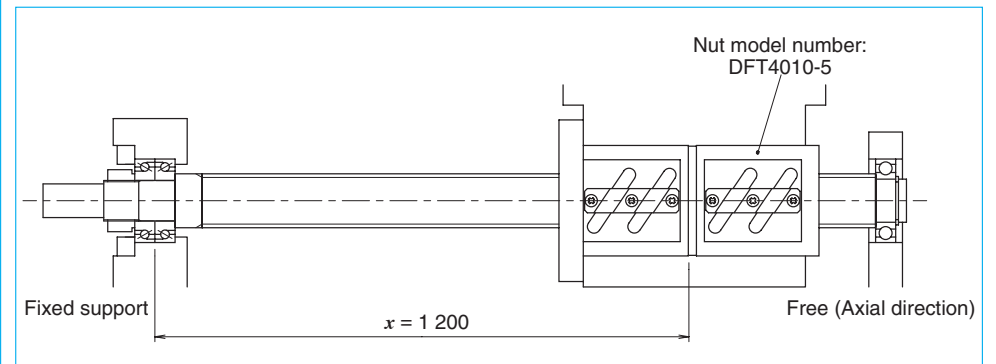

Fig. 6.6 Calculation example of axial rigidity of the screw shaft (1)

<<Calculation example of axial rigidity (2)>>

Obtain axial rigidity of the screw shaft under the conditions in Fig. 6.7.

<Use conditions>

Nut model: DFT 4010-5

From Fig. 6.7: Supporting condition:

Fixed - Fixed support (axial direction)

$$L = 1\,200 \text{ mm}$$

Distance between points of load application:

Screw shaft root diameter (from the dimension table)

$$dr = 34.4 \text{ mm}$$

<Calculation>

By formula 21), axial rigidity K_s is :

$$A = \frac{\pi}{4} dr^2 = \frac{3.14}{4} \times 34.4^2 = 929.4 \text{ (mm}^2\text{)}$$

$$K_s = \frac{4A \cdot E}{L} \times 10^{-3} = \frac{4 \times 929.4 \times 2.06 \times 10^5}{1\,200} \times 10^{-3} = 638 \text{ (N/}\mu\text{m)}$$

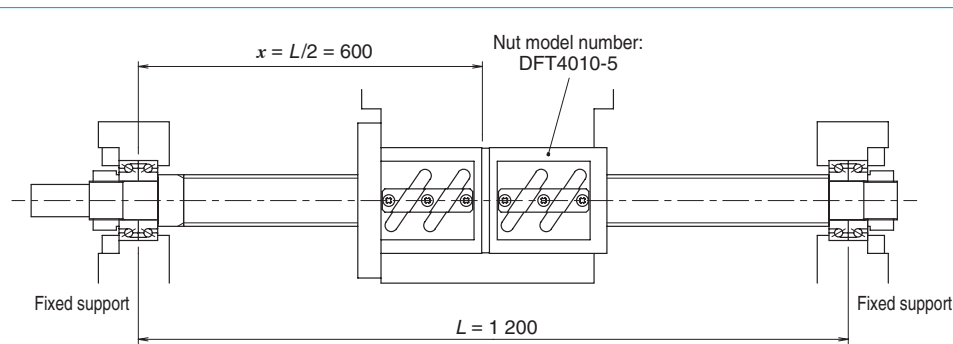

Fig. 6.7 Calculation example of axial rigidity of the screw shaft (2)

(3) Axial rigidity of the ball nut : K_N

(a) Rigidity of the nut with axial play

Theoretical rigidity value K is shown in the dimension table. The value K is obtained from the elastic deformation between screw grooves and balls when an axial load equivalent to 30% of the basic dynamic load rating C_a is applied. The criterion for the ball nut rigidity is 80% of the value listed in the table taking into consideration of deformation of the ball nut, etc. The rigidity value K_N is obtained by the following formula when the axial load " F_a " is not 30% of " C_a ".

$$K_N = 0.8 \times K \left(\frac{F_a}{0.3 C_a} \right)^{1/3} \text{ (N/}\mu\text{m)} \quad \dots 22$$

In this formula:

K : Rigidity value in dimension tables (N/μm)

F_a : Axial load (N)

C_a : Basic dynamic load rating (N)

(b) Rigidity of preloaded ball nut

Theoretical rigidity K of preloaded ball nut under an axial load is shown in each dimension table. The K is obtained from the elastic deformation of the ball rolling surface and the balls when: a preload which is equivalent to 10% of the basic dynamic load rating C_a (5% in case of the P-preload [single-nut oversize ball preload system]) is applied. The criterion for calculation of nut rigidity is 80% of the value listed in the table taking into consideration of deformation of the ball nut, etc. Rigidity K_N is obtained by the following formula when preload " F_{a0} " is not 10% (or 5%) of " C_a ".

$$K_N = 0.8 \times K \left(\frac{F_{a0}}{\varepsilon \cdot C_a} \right)^{1/3} \text{ (N/}\mu\text{m)} \quad \dots 23$$

In this formula:

K : Rigidity in the dimension tables (N/μm)

F_{a0} : Preload (N)

ε : Basic factor to calculate rigidity ($\varepsilon = 0.1$. For

P-preload use percentage of the preload to basic dynamic load rating. e.g. 0.03 for BSS and 0.015 for VSS.)

<<Calculation example of axial rigidity (3)>>

Obtain axial rigidity of the nut under the following conditions.

<Use conditions>

Nut model: SFT 4010-5

Axial load: $F_a = 6\,000 \text{ N}$

F_a = Rigidity at 0.3 C_a $K = 706 \text{ N/}\mu\text{m}$
(from the dimension table)

<Calculation>

By formula 22), axial rigidity K_N is :

$$\begin{aligned} K_N &= 0.8 \times K \left(\frac{F_a}{0.3 \cdot C_a} \right)^{1/3} \\ &= 0.8 \times 706 \times \left(\frac{6\,000}{0.3 \times 52\,000} \right)^{1/3} \\ &= 410 \text{ (N/}\mu\text{m)} \end{aligned}$$

<<Calculation example of axial rigidity of the screw shaft (4)>>

Obtain axial rigidity of the nut under the following conditions.

<Use conditions>

Nut model : DFT 4010-5

Preload : $F_{a0} = 4\,000 \text{ N}$

Rigidity K when $F_{a0} = \varepsilon C_a$: $K = 1\,376 \text{ N/}\mu\text{m}$
(from the dimension table on page B457)

Basic factor to calculate rigidity when D Preload: $\varepsilon = 0.1$

<Calculation>

By formula 23)

$$\begin{aligned} K_N &= 0.8 \times K \left(\frac{F_{a0}}{\varepsilon \cdot C_a} \right)^{1/3} \\ &= 0.8 \times 1\,376 \times \left(\frac{4\,000}{0.1 \times 52\,000} \right)^{1/3} \\ &= 1\,008 \text{ (N/}\mu\text{m)} \end{aligned}$$

The criterion of the preload to ball screw

Nut rigidity increases by a larger preload volume. But an excessive preload shortens life, and generates heat. Set the maximum preload about at 0.1 C_a (0.05 for P-Preload). **Table 6.1** shows the criteria for preload for different applications.

Table 6.1 Criteria of preload

Ball screw application	Preload (relative to dynamic load rating C_a)
Robots, material handling systems, etc.	Axial play or under 0.01 C_a
Semiconductor manufacturing systems, etc. That require highly accurate positioning	0.01 C_a – 0.04 C_a
Medium- high-speed machine tools for cutting	0.03 C_a – 0.07 C_a
Low to medium-speed systems that require especially high rigidity	0.07 C_a – 0.1 C_a

designing equipment that requires high positioning accuracy.

(b) Suppress thermal error

It is necessary to minimize the thermal error for ever increasing demand for positioning accuracy give three points below.

- Suppress heat
- Forced cooling
- Avoid effect of temperature rise

Refer to "Measures against thermal expansion" on page B40.

(4) Axial rigidity of support bearing: K_b

The rigidity (K_b) of the bearing used for ball screw support is shown in the dimension table of bearing. See page B415 for ball screw support bearings, NSKTAC C series and B425 for BSBD series.

(5) Axial rigidity of the ball nut and bearing mounting section: K_n

As the rigidity of mounting section has a profound effect on positioning accuracy, we recommend incorporating high rigidity of the mounting sections of ball nut and support bearings into the design at the early stage of designing the machine.

(a) Torsional rigidity of the feed screw system

Major torsion factors in the rotating system that bring about error in positioning accuracy are given three points below.

- Torsional deformation of the screw shaft
- Torsional deformation of the joint section
- Torsional deformation of the motor

The value of the effect of torsional strain to positioning accuracy is smaller than axial deformation. However, check the effect when

B-2-7 Friction Torque and Drive Torque

Operations that use ball screw drives require a motor torque which is equivalent to the total of following two:

- Friction torque, i.e. the friction of the ball screw itself
- Drive torque which is required for operation

"breakaway torque." This torque is 2 to 2.5 times larger than the dynamic (friction) torque due to preload which is described below. The starting friction torque quickly diminishes once the ball screw begins to move.

B-2-7.1 Friction Torque

(1) Starting friction torque (breakaway torque)

A high torque is necessary to start a ball screw. This is called "starting friction torque" or

(2) Dynamic friction torque (dynamic friction torque due to preload)

When a ball screw is moving, two types of torque generate: the dynamic friction torque due to preload and the friction torque associated with ball recirculation. JIS B1192 sets the standard of dynamic friction torque due to preload, which is the total of these two torque types. They are defined in **Fig. 7.2**.

The dynamic friction torque due to preload is calculated by the following formula. When the screw shaft is rotated as **Fig. 7.1** in the following measuring conditions, measure the nut holding power F and then multiple the distance of action line L which is perpendicular to the direction of the power F .

$$T_p = F \cdot L \quad \dots 24)$$

- Measuring rotational speed 100 min⁻¹
- Viscosity of lubrication is ISO VG 68 as prescribed in JIS K 2009.
- Remove Seals.

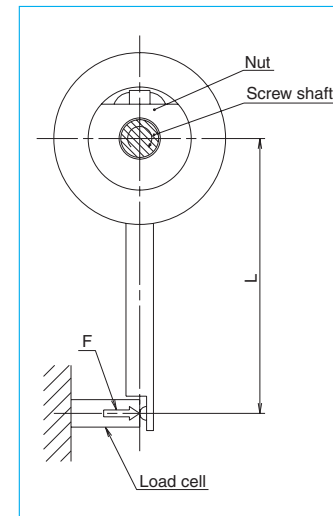

Fig. 7.1 Preload dynamic torque measuring method

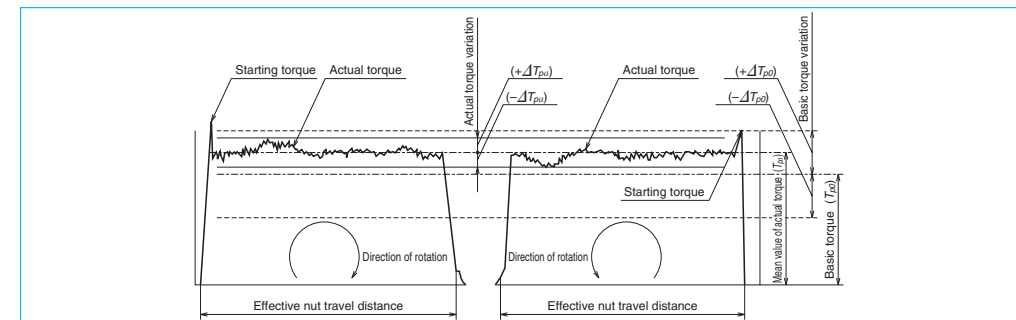

Fig. 7.2 Definitions of dynamic preloaded drag torque

(3) Calculation of basic torque

The basic torque of preloaded ball screw T_{p0} can be obtained by the following formula.

$$T_{p0} = K \frac{F_{a0} \cdot l}{2\pi} \doteq 0.014 F_{a0} \sqrt{d_m \cdot l} \quad (\text{N} \cdot \text{cm}) \quad \dots 25)$$

In this formula:

F_{a0} : Preload (N)

l : Lead (cm)

K : Torque coefficient of ball screw

$$K = \frac{0.05}{\sqrt{\tan\beta}}$$

β : Lead angle (deg.)

d_m : Ball pitch circle diameter (cm)

Allowable values of torque variation rate relative to basic torque are regulated as shown in **Table 7.1**.

7.1.

B-2-7.2 Drive Torque

(1) Operating torque of a ball screw

(a) Normal drive

The torque when converting rotational motion to linear motion (normal operation) is obtained by the following formula.

$$T_a = \frac{F_a \cdot l}{2\pi \cdot \eta_1} \quad (\text{N} \cdot \text{cm}) \quad \dots 26)$$

In this formula:

T_a : Normal operation torque (N · cm)

F_a : Axial load (N)

l : Lead (cm)

η_1 : Normal efficiency ($\eta_1 = 0.9$ to 0.95)

(b) Back-drive operation

The torque when converting linear motion to rotational motion (back-drive operation) is obtained by the following formula.

$$T_b = \frac{F_a \cdot l \cdot \eta_2}{2\pi} \quad (\text{N} \cdot \text{cm}) \quad \dots 27)$$

In this formula:

T_b : Reverse operation torque (N · cm)

η_2 : Reverse efficiency ($\eta_2 = 0.9$ to 0.95)

(c) Dynamic drag torque of the preloaded ball screw
the operation torque of preloaded ball screw can be obtained by Formula 25).

(2) Drive torque of the motor

(a) Drive torque at constant speed

The torque which is necessary to drive a ball screw at constant speed resisting to external loads can be obtained by the following formula.

$$T_1 = (T_a + T_{pmax} + T_u) \times \frac{N_1}{N_2} \quad \dots 28)$$

In this formula:

T_a : Drive torque at constant speed

$$T_a = \frac{F_a \cdot l}{2\pi \cdot \eta_1} \quad \dots 26)$$

F_a : Axial load (N)

The value of F_a in **Fig. 7.3** is:

$F_a = F + \mu \cdot m \cdot g$

F : Such as cutting force to axial direction (N)

μ : Friction coefficient of the guide way

m : Volume of the traveling section (table mass plus work mass kg)

g : Gravitational acceleration (9.80665 m/s²)

T_{pmax} : Upper limit of the dynamic friction torque of ball screw (N · cm)

T_u : Friction torque of the support bearing (N · cm)

N_1 : Number of teeth in Gear 1

N_2 : Number of teeth in Gear 2

Generally, though it depends on the type of motor, T_1 shall be kept under 30% of the motor rating torque.

(b) Drive torque at acceleration

Accelerating the ball screw resisting axial load requires the maximum torque in an operation. Drive torque necessary for this occasion can be obtained by the following formula.

$$T_2 = T_1 + J \cdot \dot{\omega} \quad \dots 29)$$

$$J = J_M + J_{G1} \left(\frac{N_1}{N_2} \right)^2 \left[J_{G2} + J_S + m \left(\frac{l}{2\pi} \right)^2 \right] \quad (\text{kg} \cdot \text{m}^2) \quad \dots 30)$$

In this formula:

T_2 : Maximum drive torque at time of acceleration (N · cm)

$\dot{\omega}$: Motor's angular acceleration (rad/s²)

J : Moment of inertia applied to the motor (kg · m²)

J_M : Moment of inertia of the motor (kg · m²)

J_{G1} : Moment of inertia of Gear 1 (kg · m²)

J_{G2} : Moment of inertia of Gear 2 (kg · m²)

J_S : Moment of inertia of the screw shaft (kg · m²)

When selecting a motor, it is necessary to examine the maximum torque of the motor relative to the drive torque T_2 at the time of acceleration of ball screw.

For the calculation of the moment of inertia of a cylindrical object (ball screw, gear, etc.), please refer to the formula below.

Table 7.1 Range of allowable values of torque variation rates (Source: JIS B 1192)

Basic torque (N · cm)		Effective length of the screw thread (mm)										
		4 000 or under					Over 4 000 and 10 000 or under					
		Slenderness ratio ⁽¹⁾ : 40 or less					Slenderness ratio ⁽¹⁾ : More than 40 and 60 or less					
		Accuracy grade				Accuracy grade				Accuracy grade		
Over	Incl.	C0	C1	C2, 3	C5	C0	C1	C2, 3	C5	C1	C2, 3	C5
20	40	±30%	±35%	±40%	±50%	±40%	±40%	±50%	±60%	—	—	—
40	60	±25%	±30%	±35%	±40%	±35%	±35%	±40%	±45%	—	—	—
60	100	±20%	±25%	±30%	±35%	±30%	±30%	±35%	±40%	—	±40%	±45%
100	250	±15%	±20%	±25%	±30%	±25%	±25%	±30%	±35%	—	±35%	±40%
250	630	±10%	±15%	±20%	±25%	±20%	±20%	±25%	±30%	—	±30%	±35%
630	1 000	—	±15%	±15%	±20%	—	—	±20%	±25%	—	±25%	±30%

Notes: 1. Slenderness ratio: The value obtained by dividing the length of the screw thread section of screw shaft (mm) by diameter of the screw shaft (mm).
2. NSK independently sets torque standards which are under 20 N · cm.

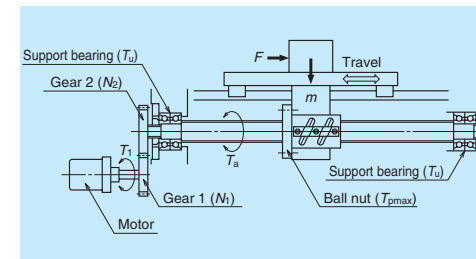

Fig. 7.3 Driving mechanism of ball screw

Formula for the moment of inertia of a cylindrical object

$$J = \frac{\pi \cdot \gamma}{32} D^4 \cdot L \quad (\text{kg} \cdot \text{cm}^2) \quad \dots 31)$$

In this formula:

γ : Material density (kg/cm³)

D : Diameter of the cylindrical object (cm)

L : Length of the cylindrical object (cm)

B-2-8 Even Load Distribution in Ball Nut (In Case of Ball Screws for High-Load Drive)

Generally, the distribution of loaded balls in a ball nut is three-dimensionally asymmetric, thus resulting in uneven load distribution to the balls and ball nut. NSK has taken the measures for even load distribution to the balls by an optimal arrangement of the position of ball recirculation circuits. Additionally, a heavier load results in a measurable axial deformation of the screw

shaft and the ball nut, thus further increasing the unevenness of load distribution. We have lessened the unevenness of load distribution to the balls by arranging the load acting point of the ball nut and the screw shaft opposite to each other. The relation between loading points and load distribution is shown in **Fig. 8.1**, while **Table. 8.1** shows the result of load distribution analysis.

Table. 8.1 The result of equalization of load distribution

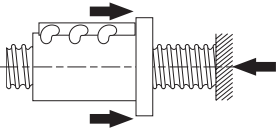
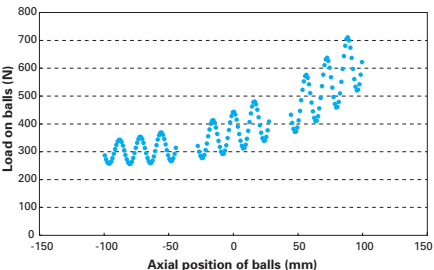
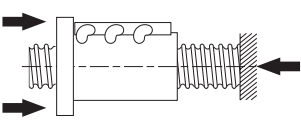
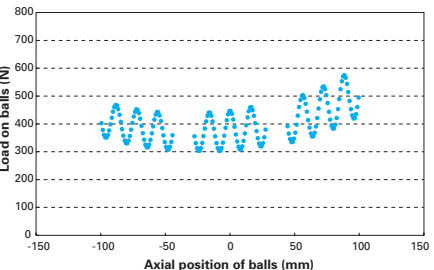
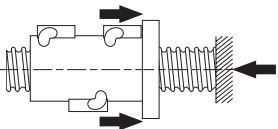
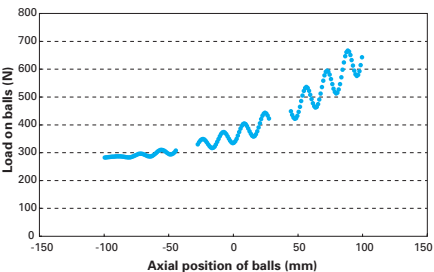
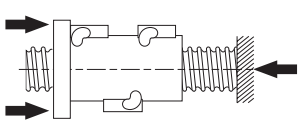
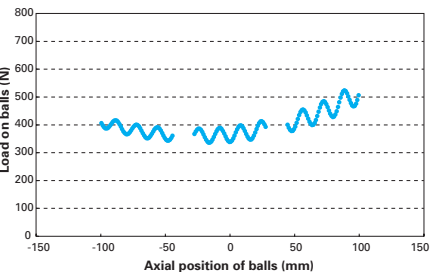
	NSK recommended mounting direction	Conventional mounting direction
Conventional design	 	 
HTF design	 	 

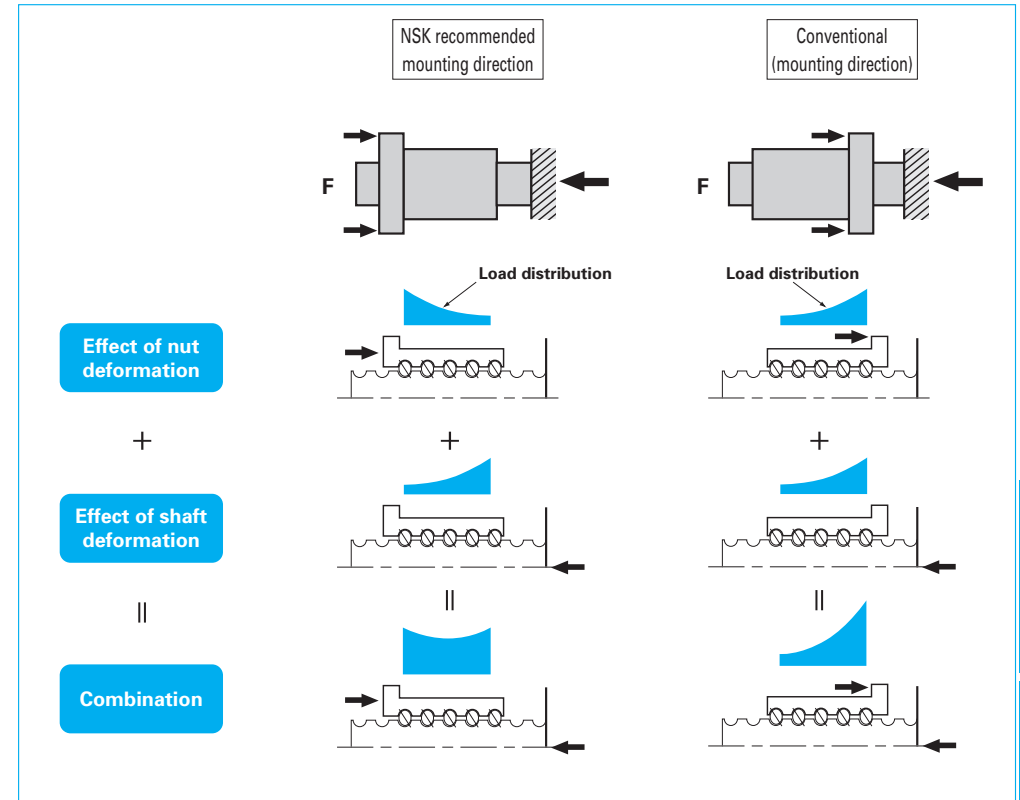

Fig. 8.1 The relationship between acting point of load and load distribution

B-2-9 Lubrication of Ball Screw

Lithium soap-based grease with base oil viscosity of 30 to 140 mm²/s (40°C) is recommended for grease lubrication and oil of ISO VG 32 to 100 for oil lubrication.

In general, a lubricant with low base oil viscosity is recommended where a ball screw is used for high-speed operation, and thus requires reducing thermal elongation of the screw shaft. On the other hand, a lubricant with high base oil viscosity is recommended for a low-speed, high-temperature operation, or a high-load and oscillating operation.

Please consult NSK about greases for high-load drives and high-temperature applications.

NSK markets "NSK Grease Unit" as the standard series products for a variety of applications. NSK Grease Unit for ball screw lubrication includes:

- 1) Various types of grease in the bellows-tube which can be instantly attached to the grease pump
- 2) Hand grease pump which is compact and easy to use
- 3) Nozzles

Table 9.1 shows NSK greases, and names of other ball screw greases.

Table 9.2 explains checking points in lubrication and standard intervals between replenishments. It is important to wipe off old grease from the screw shaft prior to applying new grease. Page D16 also explains in detail concerning the replenishing methods.

Table 9.1 Grease for ball screw

Product name	Thickener	Base oil	Base oil viscosity mm ² /s (40°C)	Range of temperature for use (°C)	Application
NSK Grease AS2	Lithium type	Mineral oil	130	-10 - 110	For general use at high load
NSK Grease PS2	Lithium type	Synthetic oil combined with Synthetic hydrocarbon oil	15.9	-50 - 110	For light load
NSK Grease LR3	Lithium type	Synthetic oil	30	-30 - 130	For high-speed medium load
NSK Grease LG2	Lithium type	Mineral oil combined with Synthetic hydrocarbon oil	32	-20 - 70	For clean environment
NSK Grease NF2	Urea composite type	Synthetic hydrocarbon oil	26	-40 - 100	For fretting resistant

*Refer to page D13 for the nature of NSK greases.

Table 9.2 Checking lubricant and intervals of replenishment

Lubricating method	Checking intervals	Check points	Replenish/replacing interval
Intermittent automatic oil supply	Once a week	Remaining volume, contamination	Supply oil when checking (depending on the tank volume)
Grease	2 - 3 months after start of use	Clean, foreign matters	Generally once a year (replenish when necessary)
Oil bath	Every day, when start to work	Oil level	Specify according to oil consumption

B-2-10 Dust Prevention for Ball Screw

If foreign matters enter inside the ball nut, all screw grooves and balls wear rapidly, or the ball screw may malfunction due to the damage of groove and/or ball recirculation system. Use bellows or telescopic pipes (**Fig. 10.1**) to keep foreign matters from entering into the feed

screw system. Install these items so as to shut foreign matters completely from the ball screw. Also it is even more effective to add seals on the ball nut as shown in **Figs. 10.2 to 10.7**. We provide seals in **Table 10.1**.

Table 10.1 Seal

	Sealing capability	Torque	Heat	grease retention	Application
Thin plastic seal	○	○	○	○	End deflector type, HMD type, BSL type
Plastic seal	×	◎	◎	×	Tube type, Deflector(bridge) type (Seal is not put on the lead of 1mm or smaller.)
Wiper seal	○	×	×	○	
X1 seal	◎	○	○	◎	HMS type, HMD type
High performance seal	◎	○	○	○	VSS type
Brush-seal	△	○	○	△	For R Series (Seal for those with the shaft diameter of 14 mm or less is plastic seal.)

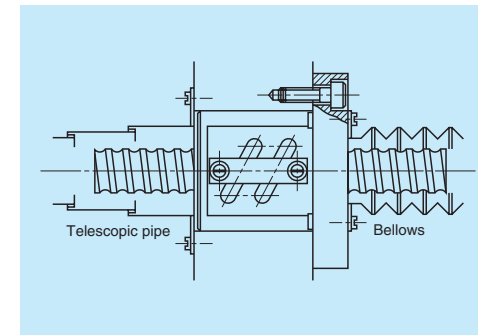

Fig. 10.1 Dust prevention by telescopic pipe and bellows

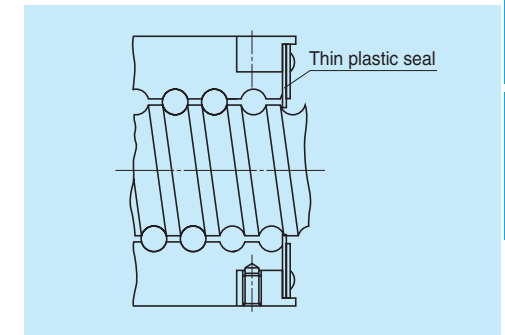

Fig. 10.2 Thin plastic seal

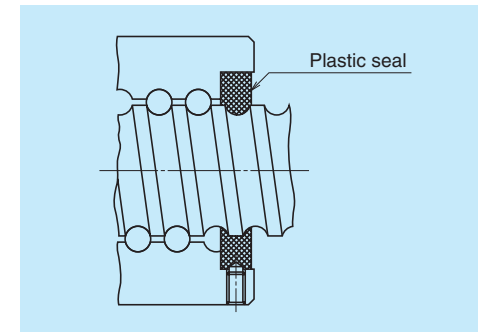

Fig. 10.3 Plastic seal

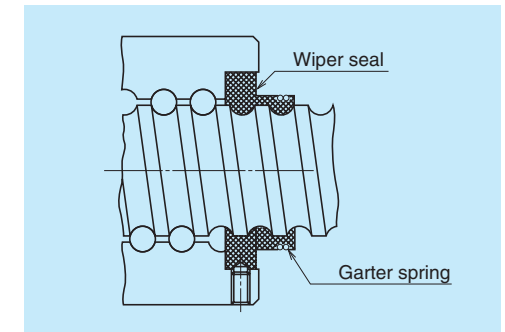

Fig. 10.4 Wiper seal

B-2-11 Rust Prevention and Surface Treatment of Ball Screws

(1) Stainless steel ball screw

KA type ball screws made of stainless steel are available. Please consult NSK for a custom made stainless steel ball screw.

(2) Types of surface treatment

The following are common types of treatment.

- Low temperature chrome plating
 - Used to prevent corrosion and light reflection, and for cosmetic purpose.
- Fluoride low temperature chrome plating
 - Fluoroplastic coating is provided following the low temperature chrome plating.
 - Resistance to corrosion is higher than low temperature chrome plating.
- Hard chrome plating
 - Very hard coating provides high resistance to both wear and corrosion.
- Electroless nickel plating
 - Creates a film of consistent thickness on complex shaped items.
 - For corrosion prevention.

(3) Recommended surface treatment

Among the surface treatments mentioned above, we recommend "Low temperature chrome plating" and "fluoride low temperature chrome plating" for rust prevention because of the result of humidity chamber test for antirust characteristics.

However, never apply any organic solvent for degreasing because it has adverse effect on antirust characteristics.

Table 11.1 Surface treatment length

	Applicable length
Low temperature chrome plating	5 m or less
Fluoride low temperature chrome plating	4 m or less

Refer to "1.3 Rust Prevention and Surface Treatment" (page D5) for the results of humidity chamber test.

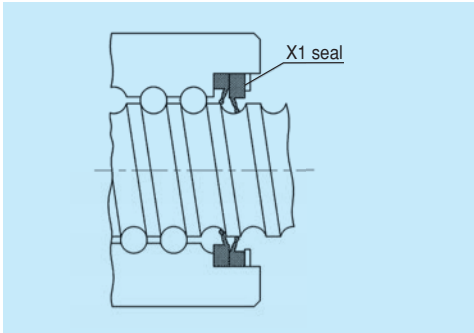

Fig. 10.5 X1 seal

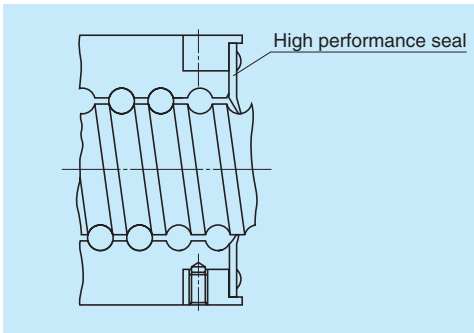

Fig. 10.6 High performance seal

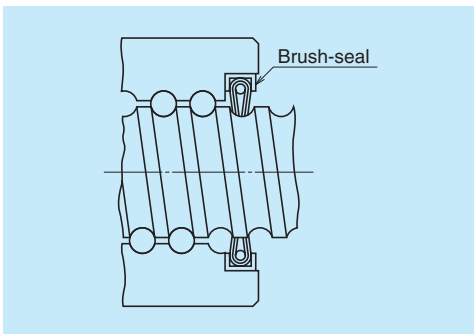

Fig. 10.7 Brush-seal for R Series

B-2-12 Ball Screw Specifications for Special Environments

B-2-12.1 Clean Environments

NSK manufactures NSK Clean Grease "LG2" and "LGU" for NSK linear guides, ball screws, and Monocarriers which are used under normal temperature and pressure in a clean room.

The LG2 and LGU grease are far more superior in stable torque characteristics than the vacuum grease which has been used as a countermeasure against dust generation. The LG2 and LGU also have a sufficient durability and dust prevention capability.

Features of "LG2" and "LGU"

- (a) Generates less dust than prevailing vacuum greases and general greases. Cleanliness is enhanced by simply switching the grease to the LG2 or the LGU.
- (b) Has extremely low and stable torque characteristics. It is ideal for high-speeds operation.
- (c) Unlike prevailing vacuum greases, the LG2 and LGU have a nature similar to general grease. Its effect is long-lasting, and sufficiently durable. They greatly contribute to minimize the frequency of maintenance.
- (d) They have an equal capability in rust prevention as general grease, and also are reliable.

When using NSK linear guides, ball screws, or Monocarriers in a clean environment, request the LG2 or LGU as a packed lubricant prior to delivery. NSK also makes bellows-tubes which contain 80 grams of the LG2 or LGU. The tube is easy to use, and is ideal for maintenance (refer to pages B413 and D19). Wash to remove adipose substances prior to use.

Refer to page D8 for their detailed nature, functions and characteristics of LG2 and LGU.

B-2-12.2 Measures for Use Under Vacuum

NSK developed MoS₂ / WS₂ sputtering and dry-filmed ball screws for equipment to be used in space. NSK also makes soft-metal film (gold and silver) ball screws to be used in a vacuum environment for semiconductor and liquid crystal display processing equipment.

Lubricants widely used for ball screws in a high vacuum are:

- Vacuum grease which uses base oil of low vapor pressure.
- Solid lubricants such as MoS₂, WS₂ used mainly for equipment in space.
- Solid lubricants by soft-metal such as gold, silver, or lead film.

When used for semiconductor and liquid crystal display manufacturing equipment, the oil of the vacuum grease evaporates and causes environmental contamination. Also, it hinders creation of a super high vacuum. MoS₂ in the state of solid lubricant generates a large volume of dust, and Mo is unsuitable for semiconductors and reformed surface. Therefore, it is not suitable for the processing machines for semiconductor and liquid crystal display.

NSK recommends solid lubricant ball screws with a long life. These ball screws are treated with special silver film by NSK's unique processing technology, and can be used in a super-high vacuum. However, because of a solid lubricant, the film may peel off and stick to surface of ball grooves repeatedly, causing the torque to rise momentarily on some occasions. The drive motor should be of large capacity to handle this drastic variation of torque.

Refer to page D7 for the test data of ball screws for vacuum.

For ball screw specifications for special environments, refer to page D2.

B-2-13 Noise and Vibration

B-2-13.1 Consideration to Lowering Noise

As the machine operates at higher speeds, noise levels tend to increase. Covering the nut section is insufficient to lower noise. NSK has abundant data (NSK Motion & Control Technical Journal No.4, etc.), and offers advice to users regarding selecting ball screw.

To lower noise level in general, the following points should be taken into consideration.

(a) Use as a large lead as possible to reduce rotational speed.

(b) Use a ball screw with smaller outer diameter as possible.

(It often requires designing for critical dimensions, mandating special specification. Please consult NSK.)

For reference, noise levels by ball screws alone are plotted below. The formula for calculation is also shown below.

(a) Average value at measuring distance of 400 mm

$$\text{dB (A)} = 25.2 \{ \log_{10} (D_w \cdot d_m \cdot n \times 10^{-5}) \} + 63.9$$
 ... 32)

(b) Upper limit at measuring distance of 400 mm
 Average value + 6 dB (A)
 D_w : Ball diameter (mm)
 d_m : Ball pitch circle dia. (mm)
 n : Rotational speed (min^{-1})

If measuring distance is 1 m, the average noise level is: Various noise levels minus 8 dB (A).

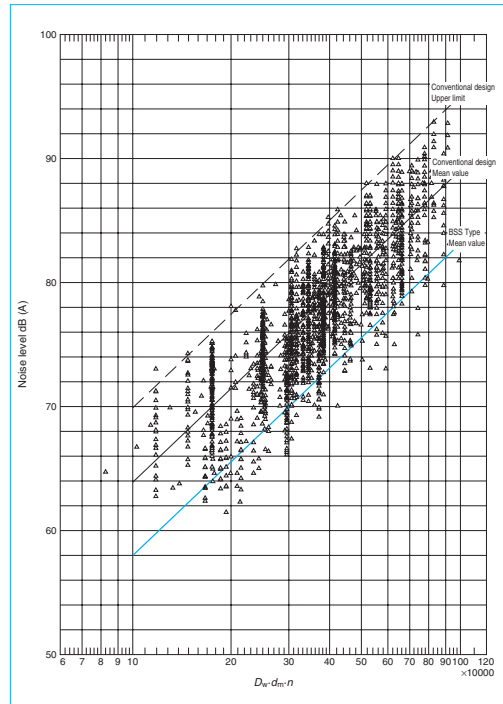

Fig. 13.1 Noise levels of ball screws

<<Example of calculation of noise levels>>

<Use conditions>

Nut model: DFT4010-5

From the dimension table: $D_w = 6.350$

$d_m = 41$

Maximum rotational speed: $2\,000 \text{ min}^{-1}$

<Calculation>

By formula 34):

$$\begin{aligned} \text{dB (A)} &= 25.2 \{ \log_{10} (D_w \cdot d_m \cdot n \times 10^{-5}) \} + 63.9 \\ &= 25.2 \{ \log_{10} (6.350 \times 41 \times 2\,000 \times 10^{-5}) \} + 63.9 \\ &= 82 \text{ dB (A)} \end{aligned}$$

The average value of noise level by ball screws alone at maximum rotational speed (measuring distance 400 mm) is 82 dB (A). Upper limit is: 82 dB (A) + 6 dB (A) = 88 dB (A). If the measuring distance is 1 m, the average value of noise level is 74 dB (A), and upper limit is 80 dB (A).

When installed, the noise of ball screw becomes higher by the noise of the machine and characteristics of machine vibration.

By using NSK S1, the noise is reduced and softened compared to conventional ball screws. The BSS type will furthermore reduce and soften the noise.

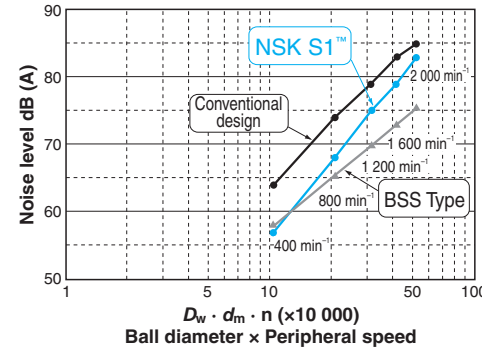

B-2-13.2 Consideration to Operational Characteristics

Smooth motion is achieved by using spacer balls on conventional ball return tube type ball screws. By using NSK S1 the smoothness is further improved. The BSS type will achieve the smoothness equivalent to ball screws with NSK S1.

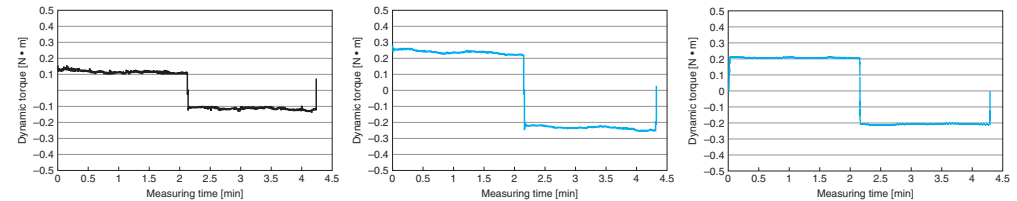

Spacer balls

NSK S1 Inserting type

BSS Type, PSS Type

B-2-13.3 Consideration to Ball Screw Support System

A ball screw has low radial rigidity because its support span is longer compare to its shaft diameter. It has only small damping capacity, requiring as much support rigidity as possible through design.

A simplified support bearing system to cut costs invites noise and vibration problems. Therefore, the necessity of consideration to the ball screw support system of both shaft ends is increasingly becoming important as the speed of machines is ever-increasing.

If one shaft end must be left unfixed without support bearing due to structural reasons, noise and vibration problems may occur. These problems are related to the natural vibration frequency of the screw shaft on the unsecured end. This problem can be averted by installing an impact damper to the shaft end (Fig. 13.2). Please consult NSK for details.

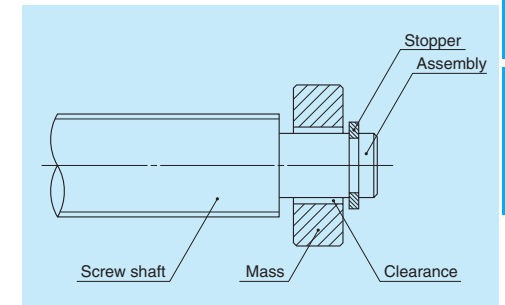
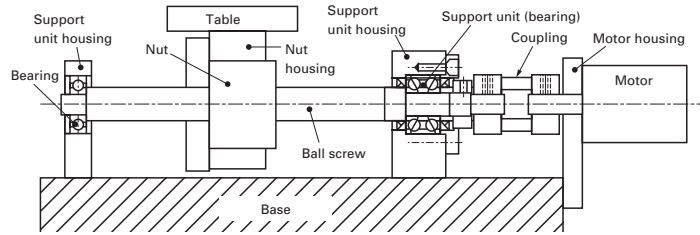

Fig. 13.2 Impact damper (Applied for patent)

B-2-14 Installation of Ball Screw

The following simplified component drawing shows a representative example of a single-axis table.



The screw shaft of the ball screw is supported by a nut and bearings, and it is driven by a motor. It is critically important to complete the centering work to ensure the predetermined operation life, functionality and accuracy of the ball screw. In general, the following accuracy is recommended for precision-class applications.

Inclination of center line: 1/2000 or less (Target: 1/5000 or less)

Eccentricity: 0.020 mm or less

The following problems could occur if an installation error negatively affected the ball screw:

- (1) Effects on durability:
 - Lowered flaking life or wearing life.
- (2) Effects on torque characteristics:
 - Increased friction torque or torque variations.
- (3) Effects on feed rate:
 - Decreased accuracy in motion.

<Inclination of center line>

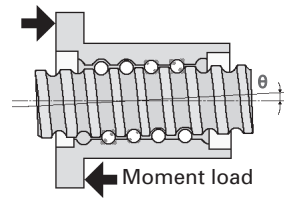

<Eccentricity>

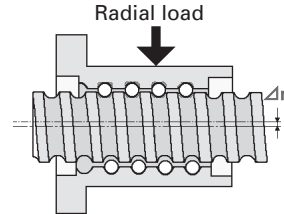

Overall View of Assembled Body

Explanations of the assembling procedure are given below, using the single-axis table as an example: In this explanation, two different installation procedures are provided: one for machine tools, where high installation accuracy is required, and another for general industrial machinery.

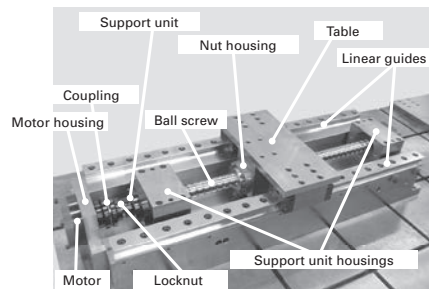

B-2-14.1 Installation Procedure for Machine Tools, Where High Installation Accuracy Is Required

The single-axis table shall be installed according to the following procedure:

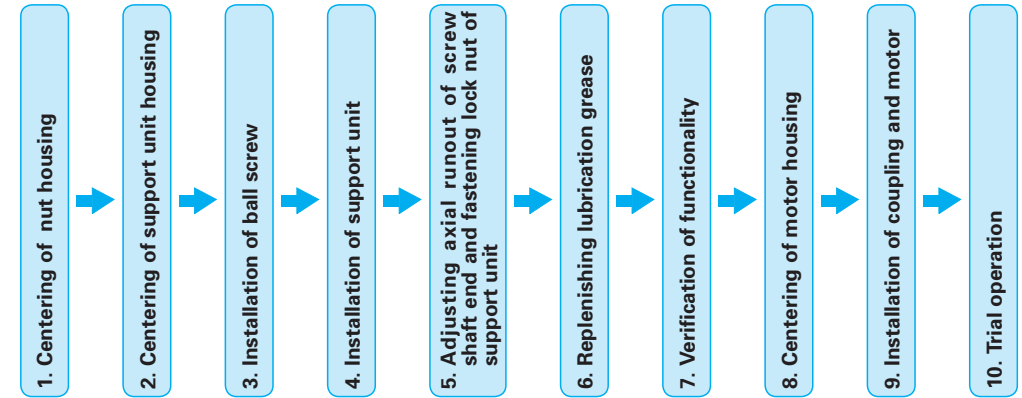

I. Jigs required for installation

Test bars:

(For the nut: one piece; for the support units: two pieces)

⇒ For centering and measurement of axial runout. The portions onto which the housing is installed (marked with the solid line) and the portions subject to measurement (a, b, c and d, marked with the broken line) shall be finished to high precision.

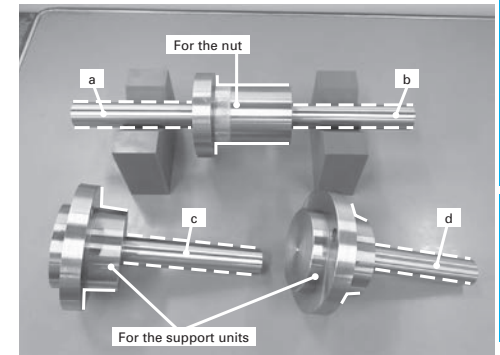

II. Installation of assembled body

1. Centering of nut housing

1-1

Turn the table over and mount the nut housing and test bar for the nut onto it.

Set up a magnet stand with a dial gauge attached, taking the rear side of the table as reference. Measure two spots at the top of the test bar for the nut by moving the magnetic stand around to check the inclination in the vertical direction.

If inclination of center line is observed, adjust the surfaces on which the nut housing is installed.

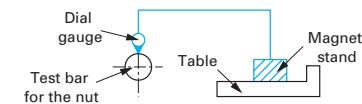
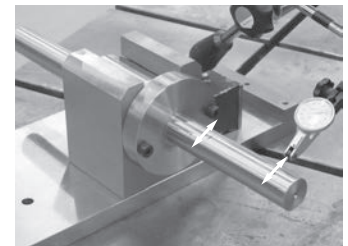

1-2
Fix the magnetic stand, with the dial gauge attached, onto a block. While pressing the block toward the reference surface of the table, move the magnet stand around. Measure the side surface of the test bar for the nut, check the inclination in the horizontal direction. If inclination of center line is observed, adjust the portion where the nut housing is installed onto the table.

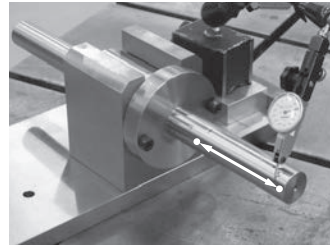
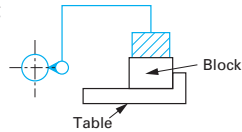

2. Centering of support unit housing

Install the linear guides onto a machine base, and then install the table, which has already been centered. (For installation of linear guides, please refer to A67 of CAT. No. 9008.)

2-1
Install the test bar for the support unit onto the support unit housing.

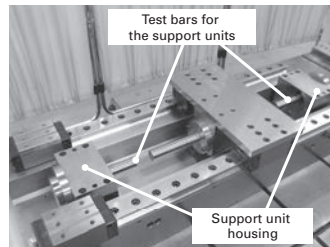

2-2
Install the magnet stand, with the dial gauge attached, using the table as reference. While moving the table, measure the two spots at the top of the test bar for the motor-side support unit to check the inclination in the vertical direction. If inclination of center line is observed, adjust the mounting surfaces of the support unit housing.

Follow the same procedure for the opposite side of the motor.

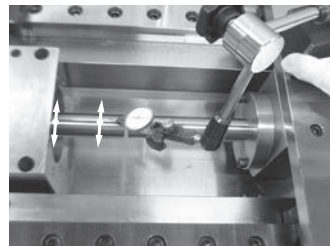
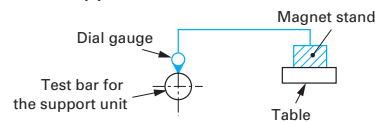

2-3
Fix the magnet stand, with the dial gauge attached, onto a block, and install the block onto the top surface of the linear guide rail. Measure the top points of the test bar for the nut and the support unit to check for eccentricity in the vertical direction.

If eccentricity is observed, adjust the mounting surface of the support unit housing.

Follow the same procedure for the opposite side of the motor.

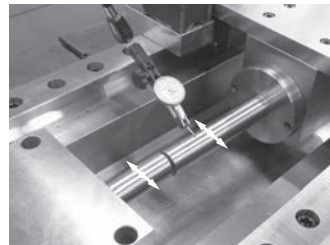
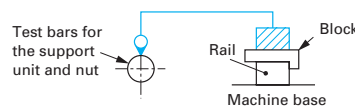

2-4
Fix the magnet stand, with the dial gauge attached, onto a block. While pressing the block toward the top surface of the linear guide rail as reference and moving it, take measurements of the side surfaces of the test bars for the nut and support unit to check for eccentricity in the horizontal direction. If eccentricity is observed, adjust the mounting surface of the support unit housing.

Follow the same procedure for the opposite side of the motor.

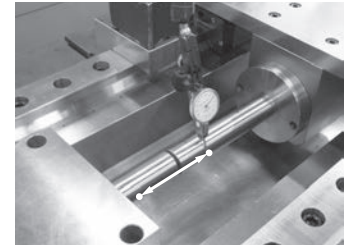
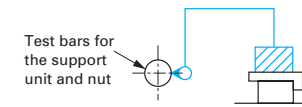

3. Installation of ball screw

Remove all test bars from the housing. Clean the outside diameter surface of the nut and the inside diameter surface of the housing using a cloth, and install the ball screw.

Apply grease to spots with metal-to-metal contact to avoid any scratches or dents. While doing this, be careful not to drop the ball screw or hit it with anything, which might cause malfunction. If the housing must be removed in order to mount the ball screw, use a positioning pin so that the housing can be mounted back in its original position.

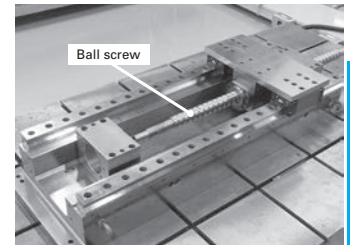

4. Installation of support unit

Insert the screw shaft into the support unit housing and mount the support units on both shaft ends. Fix the motor-side support unit to the housing. Fasten the locknut temporarily. Follow the same procedure for the opposite side of the motor.

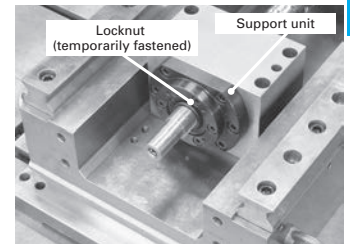

5. Adjusting axial runout of screw shaft end and fastening lock nut of support unit

Bring the dial gauge into contact with the top of the shaft end. Then, while rotating the screw shaft, measure the runout of the shaft end. While adjusting the shaft end runout, fasten the locknut to attain the required fastening torque.

Follow the same procedure for the opposite side of the motor.

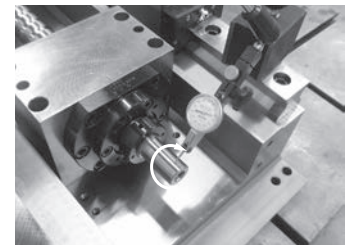

6. Replenishing lubrication grease

Wipe away the antirust oil from the empty ball screw, to which grease has not been applied, and supply grease through the grease hole to fill the inside. (Supply the grease while rotating the ball screw in the direction that moves grease toward the inside of the nut. This will lubricate the ball screw evenly.)
If you use a ball screw already filled with grease, it is not necessary to add more.

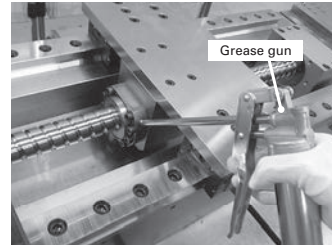

7. Verification of functionality

To check whether the ball screw has been installed accurately, verify its functionality. Measure the driving torque with a torque meter over the entire movable range of the screw. Confirm (including by touch) that there are no abnormalities.

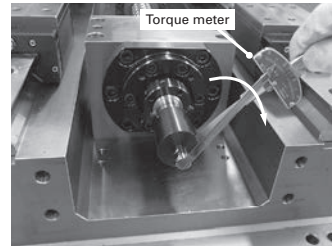

8. Centering of motor housing

8-1
Install the motor housing, and mount the dial gauge onto the shaft end of the ball screw. Rotate the screw shaft to check the inclination of the motor housing, with the stylus of the dial gauge in contact with the end face of the motor housing. If inclination of the end surface of the motor housing is observed, adjust the mounting surface of the motor housing.

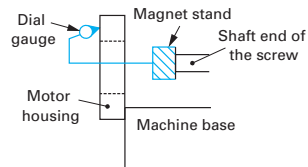

8-2
Set up the dial gauge onto the end face of the ball screw. Rotate the screw shaft to check eccentricity, with the stylus touching the inside diameter surface of the motor housing. If eccentricity is observed, adjust it by installing the motor housing appropriately.

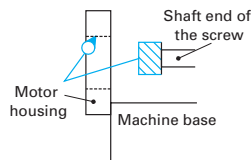

9. Installation of coupling and motor

Mount the coupling onto the shaft end of screw, and install motor.
Fasten the bolts of the coupling to connect the shaft end with motor shaft.

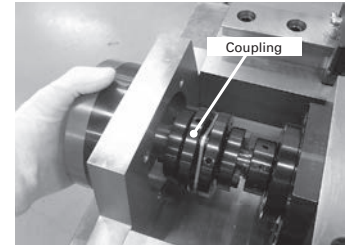

10. Trial operation

At the beginning, run the assembly at low speed to check for vibrations and noise. Then, run it at moderate speed, and finally at high speed and check for abnormalities. Then run it continuously for approximately two hours, carry out a running-in operation and at the same time check for any abnormalities. During this running-in operation, the excessive grease inside of the nut is pushed out of the nut. Wipe it away.

B-2-14.2 Installation Procedure for General Industrial Machinery

In this procedure, the ball screw is installed with the accuracy required for the linear guide. The centering of nut and table are adjusted by installing the nut housing appropriately. Since no test bars are required and the inside diameter of the nut housing does not need to be fit with the nut, the ball screw can be installed relatively easily and cheaply.

The installation procedure used for the single-axis table is shown below:

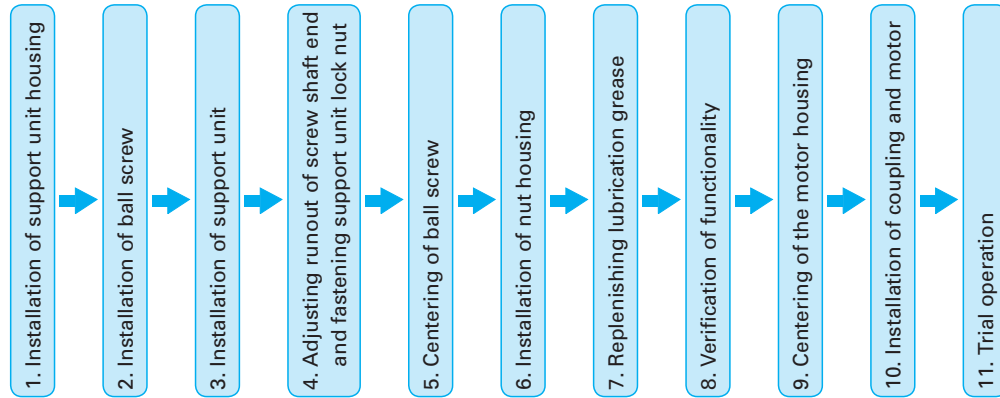

I. Installation of assembled body

1. Installation of support unit housing

Install the linear guide onto the machine base.
(For installation procedure for linear guide, please refer to A67, CAT. No. 9908.)
Place the support unit housing at the predetermined position and fasten it temporarily.

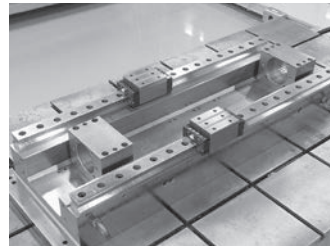

2. Installation of ball screw

Clean the outside diameter surface of the nut and the inside diameter surface of the housing using a cloth, and install the ball screw.
Apply grease to spots with metal-to-metal contact to avoid scratches and dents. While doing this, be careful not to drop the ball screw or hit it with anything, which might cause malfunction.
Conduct this task using a V-block to prevent scratches and dents.

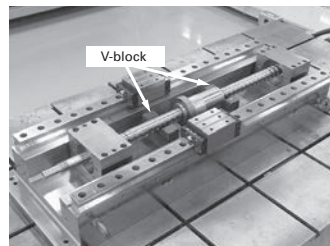

3. Installation of support unit

Insert the screw shaft into support unit housing and mount support units on both shaft ends. Fix the motor-side support unit to the housing. Fasten the locknut temporarily. Follow the same procedure for the opposite side of the motor.

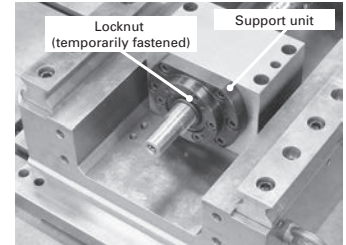

4. Adjusting runout of screw shaft end and fastening support unit locknut

Bring the dial gauge into contact with the top of the shaft end. Then, while rotating the screw shaft, measure the runout of the shaft end. While adjusting the shaft end runout, fasten the locknut to attain the required fastening torque. Follow the same procedure for the opposite side of the motor.

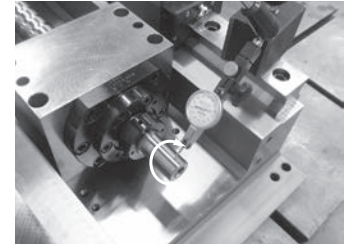

5. Centering of ball screw

5-1

Set up a magnet stand with a dial gauge attached, using the ball slide of the linear guide as reference. Measure the top of the screw shaft in the vicinity of the support unit housing both on the motor and opposite sides to check the inclination in the vertical direction. If inclination of center line is observed, adjust the mounting surface of the support unit housing.

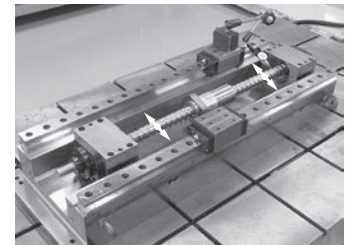
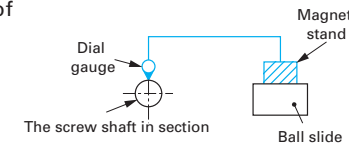

5-2

Fix the magnet stand, with the dial gauge attached, onto a block. While pressing the block toward the ball slide of the linear guide, move the block. Measure the side surface of the screw shaft in the vicinity of the support unit housing both on the motor and opposite sides to check the inclination in the horizontal direction. If inclination of center line is observed, adjust by installing support unit housing appropriately. After the adjustment, fix the support unit housings of the motor side and the opposite side.

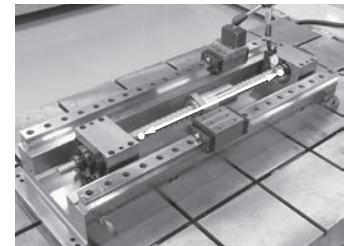
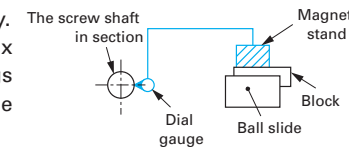

6. Installation of nut housing

6-1

Temporarily fasten the nut housing onto the table, and fasten the table, using the ball slide of the linear guide as reference surface.

To minimize the bending of the screw shaft caused by the self-weight of the nut, move the nut toward the support unit housing at the shaft end.

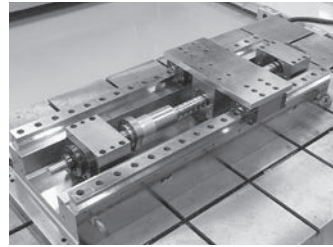

6-2

Move the table toward the nut, and fasten the nut to the nut housing.

Loosen the bolts that fasten the table to the nut housing, and re-fasten them.

Loosen the bolts that fasten the nut housing and the nut, and re-fasten them.

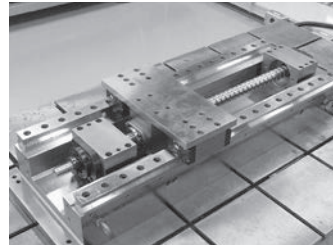

7. Replenishing lubrication grease

Wipe away the antirust oil from the empty ball screw, to which grease has not been applied, and supply grease through the grease hole to fill the inside. (Supply grease while rotating the ball screw in the direction that moves grease toward the inside of the nut. This will lubricate the ball screw evenly.)

If you use a ball screw already filled with grease, it is not necessary to add more.

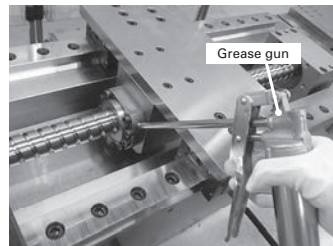

8. Verification of functionality

To check whether the ball screw has been installed accurately, verify its functionality. Measure the driving torque with a torque meter over the entire movable range of the screw.

Confirm (including by touch) that there are no abnormalities.

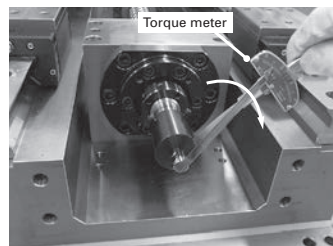

9. Centering of motor housing

9-1

Install the motor housing, and mount the dial gauge onto the end face of the ball screw. Rotate the screw shaft to check the inclination of the motor housing, with the stylus of the dial gauge in contact with the end face of the motor housing. If inclination of center line is observed, adjust the mounting surface of the motor housing.

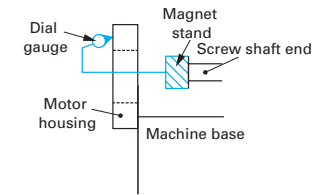

9-2

Set up the dial gauge onto the end face of the screw shaft. Rotate the screw shaft to check eccentricity, with the stylus touching the inside-diameter surface of the motor housing. If eccentricity is observed, adjust it by installing the motor housing appropriately.

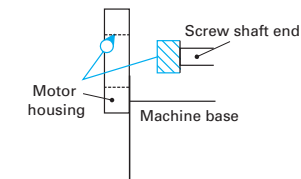

10. Installation of coupling and motor

Mount the coupling onto the shaft end, and install the motor. Fasten the bolts of the coupling to connect the shaft end with the motor shaft.

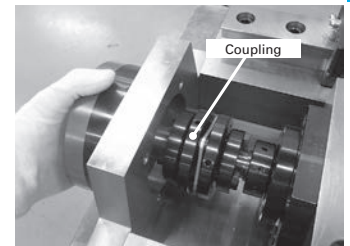

11. Trial operation

At the beginning, run the assembly at low speed to check for vibrations and noise. Then, run it at moderate speed, and finally at high speed and check for abnormalities. Then run it continuously for approximately two hours, carry out a running-in operation and at the same time check for any abnormalities. During this running-in operation, the excessive grease inside of the nut is pushed out of the nut. Wipe it away.

B-2-15 Precautions for Designing Ball Screw

B-2-15.1 Safety System

As shown in the illustration on page B352, a stopper is installed in some cases to prevent the nut from overrunning due to malfunction of the safety system of the machine itself, or human error during operation.

The travel stopper should be installed at a place where it will not come into contact with the nut when the nut reaches the designed stroke end.

An impact absorbing travel stopper (NSK patent, refer to page B414) is available at NSK.

B-2-15.2 Design Cautions to Assembling Ball Screw

(1) Cutting through the thread screw to the end

For some recirculation system, such as the deflector(bridge) type, end cap type, S1 specification (High-Load drive ball screws etc.) and a part of end deflector type, one end of the thread screw should be cut through to the end of the major diameter. This is necessary to assemble the ball nut to the screw shaft (Fig. 15.1).

In this case, the shaft end diameter, to where this "cut-through thread" is made, should be 0.2 mm or smaller than the ball groove root diameter " d_r ". (See the dimension table.) A similar precaution is required when it is absolutely necessary to remove the nut from the screw shaft in order to install the ball screw to the machine. Also, in case using the cut-through end as the shoulder of the support bearing, make certain that a sufficient amount of the effective flat surface is left from the root diameter. If it is insufficient, the bearing cannot be installed perpendicularly to the bearing seat. (Fig. 15.2)

(2) Designing the screw shaft end and the nut mounting area

When installing a ball screw to the machine, avoid a design which makes it necessary to separate the nut from the screw shaft as shown in Fig. 15.3. If separated, the balls may fall out. The separation may also deteriorate the ball screw accuracy, or may damage the ball screw. If separating them is unavoidable, please furnish NSK with the component which is to be installed between the nut and screw shaft. NSK will install the component prior to delivery.

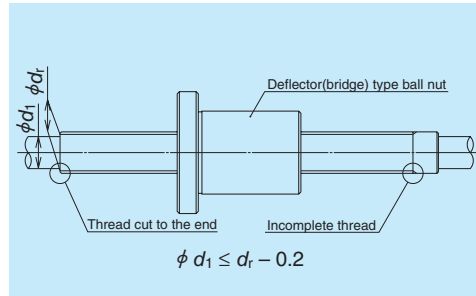

Fig. 15.1 Shaft end of a deflector (bridge) recirculation system ball screw

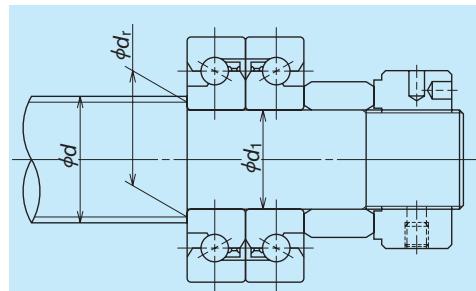

Fig. 15.2 Support bearing and end face (shoulder) for installation

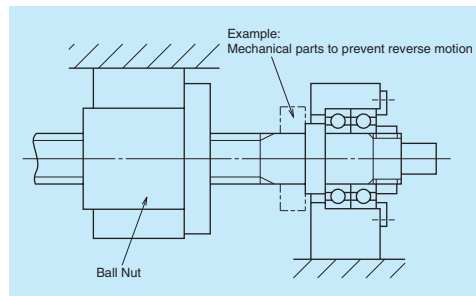

Fig. 15.3 Nut and ball screw are required to be separated when installing in this structure.

(3) Removing the nut from the screw shaft at the time of assembly

If it is unavoidable, use an arbor (Fig. 15.4), keeping the balls in the nut. In this case, the outside diameter of the arbor should be approximately 0.2 mm to 0.4 mm smaller than the ball groove root diameter " d_r ".

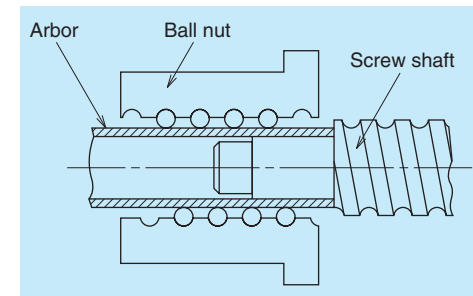

Fig. 15.4 Arbor to install and remove nut

(4) Centering of the ball nut when installing

When installing the nut as shown in Fig. 15.5, provide a space between the housing and the nut body diameter, allowing the centering to be performed.

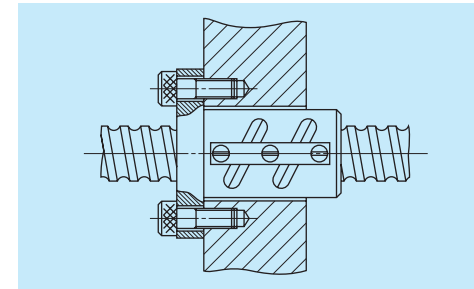

Fig. 15.5 Fixing a ball nut by flange

(5) Preventing the thread screw of nut from loosening

When installing and securing the nut to the housing at the thread screw section, as in the case for RNCT type of R Series ball screws, apply an agent which prevents the nut from loosening.

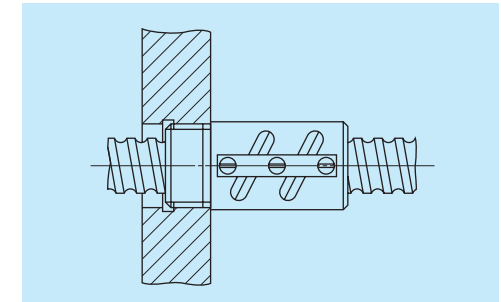

Fig. 15.6 Fixing a ball nut with thread screw

(6) Installation of brush-seal to the nut

If a brush-seal is installed at the thread screw side of the nut similar to the RNCT type which comes with a thread screw, the brush-seal should be secured as shown in Fig. 15.7.

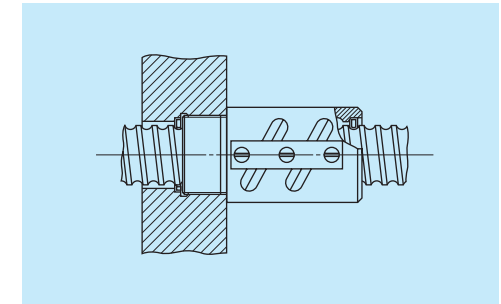

Fig. 15.7 Installation of brush-seal to a ball nut with thread screw

B-2-15.3 Effective Stroke of Ball Screw

When hardened by the induction hardening, the hardness of a ball screw may be slightly low at both ends of the screw section. Consider this low hardness prior to determining the length of effective stroke. Please consult NSK for details.

B-2-15.4 Matching after Delivery

When, after the delivery of a ball screw, you require drill knock pin hole on the screw shaft end, or at the nut mounting area, please inform NSK on the position and size of the hole. NSK will take a measure and protect designated spots from heat treatment prior to delivery to make subsequent machining easy.

B-2-15.5 "NSK K1™" Lubrication Unit

When using the NSK K1 lubrication unit, be aware of the operating temperature and chemicals that come to contact the unit for keeping the K1's best performance.

Temperature range for use:

Maximum temperature; 50°C

Momentary maximum temperature; 80°C

Chemicals that should not come to contact:

Do not leave the K1 unit in organic solvent, white kerosene such as hexane, thinner which removes oil, and rust preventive oil which contains white kerosene.

Water-type cutting oil, oil-type cutting oil, grease such as mineral-type AS2 and ester-type PS2 do not damage the K1 unit.

B-2-16 Shaft End Machining

You require to machine shaft ends in the following three occasions.

- * Precision ball screws with blank shaft end.
- * Ball screws in R Series with blank shaft end (see page B349).
- * Additional machining of a completed ball screw

The following are the summaries of machining of these shaft ends. For details, please contact NSK.

(1) Machining of blank shaft ends of precision ball screws

(a) Cutting screw shaft

Use a cutting whetstone or the like to cut the shaft, leaving stock for turning. Keep the nut in the assembled state to the screw shaft, and open only one side of the plastic wrapping bag, expose only the shaft end section to be machined, and then cut the screw shaft. This prevents foreign matters from entering to the ball screw section. Do the same for other machining.

(b) Precautions in cutting shaft end

Outside of the screw shaft is ground with precision (excluding R Series). There is a center hole in the ends. Use them for centering. Do not rotate the shaft quickly or stop it suddenly, or the nut might move along the shaft. We recommend securing the nut with tape. To machine a very long shaft, apply work rests to the screw shaft surface to suppress vibration (especially caused by critical speed).

(c) Turning by lathe

Cut to the length, turn shaft end steps, turn thread screw, and provide the center hole. Refer to JIS B1192 which sets standards for the shaft end accuracy.

(d) Processing by grinding

Apply the same precautions as for cutting for centering, securing nut, and work rest. Grind sections where the bearings and a "Spann ring" are installed.

e) Milling processing

Process keyways and tooth seats for lock washers.

(f) Deburring, washing, and rust prevention
Wash with clean white kerosene after processing. Apply lubricant for immediate use. For later use, apply rust preventive agent.

Note: Contact NSK if nut is accidentally removed.

B-2-17 Ball Screw Selection Exercise

Drill 1: High-speed transporting system

1. Design conditions

Table mass :	$m_1 = 40 \text{ kg}$
Mass of the transporting item :	$m_2 = 20 \text{ kg}$
Maximum stroke :	$S_{\text{max}} = 700 \text{ mm}$
Rapid traverse speed :	$V_{\text{max}} = 1\,000 \text{ mm/sec}$ (60 m/min)
Positioning accuracy :	$\pm 0.05/700 \text{ mm}$ (0.005 mm/pulse)
Repeatability :	$\pm 0.005 \text{ mm}$
Required life :	$L_t = 25\,000 \text{ h}$ (5 years)
Guide way (rolling) :	$\mu = 0.01$ (friction coefficient)
Drive motor :	AC servo motor
	$(N_{\text{max}} = 3\,000 \text{ min}^{-1})$

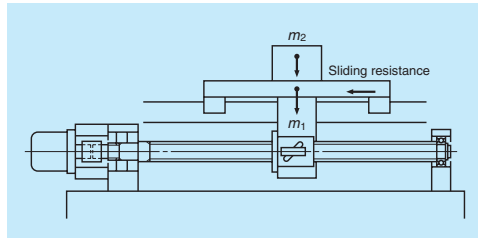

Fig. 16.1 System appearance

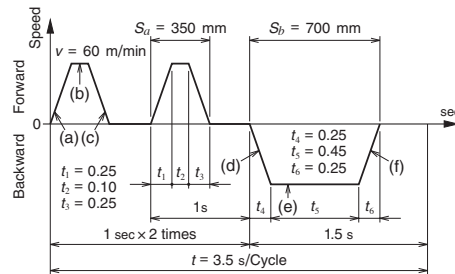

Fig. 16.2 Operating condition

2. Selection of basic factors

(1) Selection of accuracy grade and axial play

According to **Table 4.1** "Accuracy grades of ball screw and their application" on page B19, the accuracy grade of ball screws for Cartesian type industrial robots is C5 to Ct10.

From the following conditions in design, the axial play should be 0.005 mm or less.

Repeatability : $\pm 0.005 \text{ (mm)}$

Resolution : 0.005 mm/pulse

According to **Table 4.2** "Combinations of accuracy grades and axial play" on page B20, you will require the accuracy grade C5 to satisfy the axial play of 0.005 mm or less. Therefore select the accuracy grade C5, and the axial play of 0 mm (Z-preload).

(2) Selection of lead

Calculate the lead l based on maximum speed of AC servo motor and the rapid traverse speed V_{max} .

$$l \geq \frac{V_{\text{max}}}{N_{\text{max}}} = \frac{1\,000 \times 60}{3\,000} = 20 \text{ (mm)}$$

Select a lead l of 20 mm or larger.

(3) Selection of screw shaft diameter

According to the **Table 4.4** "Shaft diameter, lead and stroke of standard ball screw" on page B21, the screw shaft diameter d which has a lead l larger than 20 mm should be in the range of 15 mm to 32 mm. Select the smallest 15 mm.

(4) Selection of stroke

From the **Table 4.4** "Screw shaft diameter, lead, and stroke of standard ball screw" on page B21, a ball screw with shaft diameter (d) of 15 mm and lead (l) of 20 mm meets maximum stroke of 700 mm, therefore it is possible to select from the standard ball screws. The primary selection is as follows:

Primary selection:	
Shaft diameter :	15 (mm)
Lead :	20 (mm)
Stroke :	700 (mm)
Accuracy grade :	C5
Axial play :	Z

3. Confirmation of standard ball screw

In consideration of delivery time and price, select from the standard ball screws with finished shaft ends.

Primary candidate: W1507FA-3PG-C5Z20

4. Basic safety check

Let's examine the primary candidate.

(1) Allowable axial load

[1] Calculation of allowable axial load

From **Fig. 16.2**: Acceleration α_1 at accelerating / decelerating is:

$$\alpha_1 = \frac{V_{\text{max}}}{t_1} = \frac{1\,000}{0.25} = 4\,000 \text{ (mm/s}^2\text{)} = 4 \text{ (m/s}^2\text{)}$$

Axial load F_1 is:

(At the time of acceleration (a)(d))

$$\begin{aligned} F_1 &= \mu (m_1 + m_2) \times g + (m_1 + m_2) \times \alpha_1 \\ &= 0.01 \times (40 + 20) \times 9.80665 + (40 + 20) \times 4 \\ &= 246 \text{ (N)} \end{aligned}$$

(At the time of constant speed (b)(e))

$$F_2 = \mu (m_1 + m_2) \times g = 0.01 \times (40 + 20) \times 9.80665 = 6 \text{ (N)}$$

(At the time of deceleration (c)(f))

$$\begin{aligned} F_3 &= -\mu (m_1 + m_2) \times g + (m_1 + m_2) \times \alpha_1 \\ &= -0.01 \times (40 + 20) \times 9.80665 + (40 + 20) \times 4 \\ &= 234 \text{ (N)} \end{aligned}$$

Thus, the maximum axial load P is 246 N.

[2] Buckling load

W1507FA-3PG-C5Z20 has the support length of 804 mm ("La" as per the dimension table on page B193), and must support maximum axial load (P) of 246 (N). The supporting condition of screw shaft is "Fixed - Simple", and the supporting condition of ball nut is "Fixed". Due to the direction of the load, the whole ball screw supporting condition is "Fixed - Fixed" support (Factor $m = 19.9$).

From formula 2) on page B44:

$$d \geq \left[\frac{P \cdot L_a^2}{m} \times 10^{-4} \right]^{1/4} = \left[\frac{246 \times 804^2}{19.9} \times 10^{-4} \right]^{1/4} = 5.3 \text{ (mm)}$$

W1507FA-3PG-C5Z20 has the dimension (dr) of 12.2 mm as per the dimension chart (page B193) and therefore meets the condition.

Result: Acceptable

(2) Allowable rotational speed

The permissible rotational speed listed in the dimension table is $3\,000 \text{ min}^{-1}$. Since the motor maximum rotational speed is $3\,000 \text{ min}^{-1}$, the operation is in the range of permissible rotational speed.

Result: Acceptable

(3) Checking life expectation

[1] Mean load F_m and mean rotational speed N_m
From the calculation of axial load, rotational speed N_i and the operating time t_i is:

(At the time of acceleration (a)(d))

$$F_1 = 246 \text{ (N)}$$

$$N_1 = \frac{n}{2} = \frac{3\,000}{2} = 1\,500 \text{ (min}^{-1}\text{)}$$

$$t_a = 2 \times t_1 + t_4 = 0.75 \text{ (s)}$$

(At the time of constant speed (b)(e))

$$F_2 = 6 \text{ (N)}$$

$$N_2 = 3\,000 \text{ (min}^{-1}\text{)}$$

$$t_b = 2 \times t_2 + t_5 = 0.65 \text{ (s)}$$

(At the time of deceleration (c)(f))

$$F_3 = 234 \text{ (N)}$$

$$N_3 = 1\,500 \text{ (min}^{-1}\text{)}$$

$$t_c = 2 \times t_3 + t_6 = 0.75 \text{ (s)}$$

Calculation result is shown in **Table 16.1**

Table 16.1 Axial load and rotational speed

Operating condition	Axial load (N)	Rotational speed (mean) (min ⁻¹)	Operating time (s)
(a) (d)	$F_1 = 246$	$N_1 = 1\,500$	$t_a = 0.75$
(b) (e)	$F_2 = 6$	$N_2 = 3\,000$	$t_b = 0.65$
(c) (f)	$F_3 = 234$	$N_3 = 1\,500$	$t_c = 0.75$

From the formulas 11) and 12) on page B53:

$$F_m = \left[\frac{F_1^3 \cdot N_1 \cdot t_a + F_2^3 \cdot N_2 \cdot t_b + F_3^3 \cdot N_3 \cdot t_c}{N_1 \cdot t_a + N_2 \cdot t_b + N_3 \cdot t_c} \right]^{1/3} = 195 \text{ (N)}$$

$$N_m = \frac{N_1 \cdot t_a + N_2 \cdot t_b + N_3 \cdot t_c}{t} = 1\,200 \text{ (min}^{-1}\text{)}$$

[2] Calculation of life expectancy

At the basic dynamic load rating C_a of W1507FA-3PG-C5Z20 (Clearance Z) is 3 870 N (as per the dimension table on page B193), from the formulas 8) and 9) on page B53:

$$L_t = \left(\frac{C_a}{F_m \cdot f_w} \right)^3 \times \frac{1}{60 N_m} \times 10^6$$

$$= \left(\frac{3\,870}{195 \times 1.2} \right)^3 \times \frac{1}{60 \times 1\,200} \times 10^6$$

$$\doteq 62\,800$$

The ball screw satisfies the required life.

Result: Acceptable

5. Check for other requirements

(1) Accuracy and axial play

As per the dimension table on page B180 and **Table 1.2** for the permissible value of lead accuracy on page B38:

According to **Table 1.2**:

Accuracy grade: C5

$$e_p = \pm 0.035/800 \text{ (mm)}$$

$$v_u = 0.025 \text{ (mm)}$$

This grade satisfies the required positioning accuracy of $\pm 0.05/700$ mm.

The checking of axial play is omitted here since it is explained in "2. Selection of basic factors."

(2) Drive torque

Required specifications are as follows.

Motor rotational speed: 3 000 min⁻¹

Time to reach maximum speed: Less than 0.25 sec

[1] Load (converted to the motor axis)

Using the formula 30) and 31) on page B64, calculate the moment of inertia whereas γ is the material density of the ball screw.

(Screw shaft)

$$J_b = \frac{\pi \cdot \gamma \cdot D^4 \cdot L}{32} = \frac{\pi \times 7.8 \times 10^3}{32} \times 1.5^4 \times 80$$

$$= 0.31 \text{ (kg} \cdot \text{cm}^2)$$

(Moving part)

$$J_w = m \times \left(\frac{l}{2\pi} \right)^2 = 60 \times \left(\frac{2}{2\pi} \right)^2$$

$$= 6.1 \text{ (kg} \cdot \text{cm}^2)$$

(Coupling)

$$J_c = 0.25 \text{ (kg} \cdot \text{cm}^2) \cdots \text{Temporary}$$

(As a whole)

Moment of inertia of the ball screw J_L is:

$$J_L = J_b + J_w + J_c$$

$$= 0.31 + 6.1 + 0.25$$

$$= 6.7 \times 10^{-4} \text{ (kg} \cdot \text{m}^2)$$

[2] Driving torque

We assume that WBK12-01 compact light load type is used as recommended for W1507FA-3PG-C5Z20, and the moment of inertia of motor (J_M) is 3.1 (kg · cm²) (3.1 × 10⁻⁴ kg · m²).

(At the time of constant speed)

The torque which is necessary to drive the ball screw at a constant speed resisting to external loads is: per formula 28) on page B64

$$T_1 = T_a + T_{pmax} + T_u$$

In this formula, T_a is the drive torque at constant speed, T_{pmax} is the upper limit of the dynamic friction torque of ball screw, and T_u is the friction torque of the support bearings.

From the chart on pages B193 and B400, (T_{pmax}) is 7.8 (N · cm) and (T_u) is 2.1 (N · cm) respectively.

$$T_a = \frac{F_a \cdot l}{2\pi\eta_1}$$

Using formula 26) on page B63, the drive torque at a constant speed T_1 is:

$$T_1 = \frac{F_a \cdot l}{2\pi \cdot \eta_1} + T_{pmax} + T_u$$

$$= \frac{6 \times 2}{2\pi \times 0.9} + 7.8 + 2.1$$

$$= 12 \text{ (N} \cdot \text{cm)} = 0.12 \text{ (N} \cdot \text{m)}$$

(At the time of acceleration)

The drive torque necessary for accelerating the ball screw resisting axial load can be calculated by the formula 29) on page 64.

$$T_2 = T_1 + J \cdot \frac{2\pi \cdot n}{60t_1}$$

$$= T_1 + (J_L + J_M) \cdot \frac{2\pi \cdot n}{60t_1}$$

$$= 0.12 + (6.7 \times 10^{-4} + 3.1 \times 10^{-4}) \frac{2\pi \times 3\,000}{60 \times 0.25}$$

$$= 1.35 \text{ (N} \cdot \text{m)}$$

(At the time of deceleration)

Similarly at the time of acceleration.

$$T_3 = T_1 - J \cdot \frac{2\pi \cdot n}{60t_3}$$

$$= T_1 - (J_L + J_M) \cdot \frac{2\pi \cdot n}{60t_3}$$

$$= 0.12 - (6.7 \times 10^{-4} + 3.1 \times 10^{-4}) \frac{2\pi \times 3\,000}{60 \times 0.25}$$

$$= -1.11 \text{ (N} \cdot \text{m)}$$

[3] Selection of motor

Selection conditions are as follows.

Maximum rotational speed: $N_M \geq 3\,000$ (min⁻¹)

Motor rating torque: $T_M \geq T_{rms}$ (N · m)
(T_{rms} : Effective torque)

Moment of inertia of the motor: $J_M > J_L/3$ or more
Form above: select an AC servo motor with the following specifications.

Motor specifications:

Rating power output: $W_M = 300$ (W)

Maximum rotational speed:

$$N_M = 3\,000 \text{ (min}^{-1})$$

Rating torque: $T_M = 1$ (N · m) = 1 × 10² (N · cm)

Moment of inertia: $J_M = 3.1 \times 10^{-4}$ (kg · m²)
= 3.1 (kg · cm²)

[4] Check on effective torque

Effective torque T_{rms} can be calculated as follows:

$$T_{rms} = \sqrt{\frac{T_2^2 \times t_a + T_1^2 \times t_b + T_3^2 \times t_c}{t}}$$

$$= \sqrt{\frac{1.35^2 \times 0.75 + 0.12^2 \times 0.55 + 1.11^2 \times 0.75}{3.5}}$$

$$= 0.81$$

Thus the condition of " $T_M \geq T_{rms}$ " is cleared.

[5] Check on time to reach maximum speed

The time required to reach the rapid traverse speed can be calculated as follows. Whereas $T_M' = 2 \times T_M$:

$$t_a = \frac{(J_L + J_M) \times 2\pi \times n}{(T_M' - T_1)} \times 1.4$$

$$= \frac{(6.7 \times 10^{-4} + 3.1 \times 10^{-4}) \times 2\pi \times 3\,000}{(2 \times 1 - 0.12) \times 60} \times 1.4$$

$$= 0.23$$

Thus the ball screw meets the requirement of "0.25 sec or less".

From the above, use W1507FA-3PG-C5Z20

Drill 2: Processing table for special machines

1. Design conditions

- Table mass: $m_1 = 1\,000\text{ kg}$
- Mass of the work: $m_2 = 600\text{ kg}$
- Maximum stroke: $S_{\max} = 1\,000\text{ mm}$
- Maximum speed: $V_{\max} = 15\,000\text{ mm/min}$
- Positioning accuracy: $\pm 0.035/1\,000\text{ mm (no load)}$
- * Attitude accuracy of the table and thermal displacement are not included in the accuracy requirement of the ball screw.
- Repeatability: $\pm 0.005\text{ mm (no load)}$
- Lost motion: $0.020\text{ mm (no load)}$
- Required life expectancy: $L_i = 20\,000\text{ h}$
($16^{\text{h}} \times 250^{\text{days}} \times 10^{\text{years}} \times 0.5^{\text{rate of operation}}$)
- Guide way (sliding): $\mu = 0.15$
(friction coefficient)
- Processing: Milling and drilling
- Drive motor: AC servo motor
($N_{\max} = 2\,000\text{ min}^{-1}$)

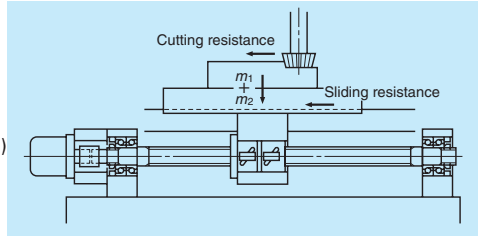

Fig. 16.3 System appearance

Table 16.2 Operating conditions

Operation	Axial load (N)		Feed speed (mm/min)	Use time ratio (%)
	Cutting resistance	Sliding resistance		
Rapid traverse	0	2 354	15 000	30
Light/medium cutting	4 000	2 354	500	50
Heavy cutting	8 000	2 354	100	20

- * Sliding resistance: $F_r = \mu (m_1 + m_2) g = 0.15 \times (1\,000 + 600) \times 9.80665 = 2\,354\text{ (N)}$
- * Ignore the inertia force at the time of acceleration/deceleration because their time rate is negligibly short.

2. Selection of basic factors

(1) Selection of accuracy grade and axial play

The proper accuracy grade for machining centers should be in the range from C1 to C5 according to "Table 4.1 Accuracy grades of ball screws and their applications" on page B19. Assuming the nut length is 200 mm and margin stroke is 100 mm, the shaft length L_0 is obtained as follows:

$$L_0 = \text{Maximum stroke} + \text{nut length} + \text{margin}$$

$$= 1\,000 = (200) + (100) = 1\,300$$

From "Table 1.2 Tolerance on specified travel and travel variation of the positioning ball screws" on page B38, the accuracy factors which satisfy the required function are:

Accuracy C3 grade

$$e_p = \pm 0.029/1\,600\text{ (mm)}$$

$$v_u = 0.018\text{ (mm)}$$

Considering the importance of lost motion, select the Z code (axial play 0 mm and less) for the axial play.

(2) Selection of lead

From the maximum rotational speed of AC servo motor N_{\max} and rapid traverse speed of table V_{\max} , lead l is:

$$l \geq \frac{V_{\max}}{N_{\max}} = \frac{15\,000}{2\,000} = 7.5\text{ (mm)}$$

A larger lead l would be beneficial for a higher feed speed. But from the view of the control system (resolution), the lead l is limited to 8 mm or 10 mm.

(3) Selection of screw shaft diameter

According to Table 4.4 "Screw shaft diameter, lead and stroke of standard ball screw" on page B21, the screw shaft diameter with the lead of 8 mm or 10 mm are in the range of 10 mm to 50 mm. Placing more importance on rigidity than to the volume of lost motion, select a relatively large size in the range of 32 mm to 50 mm.

(4) Selection of stroke

Select 1 000 mm, the maximum stroke as specified in the design condition.

Primary selection:

- Standard ball screw
- Shaft diameter: 32, 36, 40, 45, 50 mm
- Lead: 8, 10 mm
- Stroke: 1 000 mm
- grade: C3
- Axial play code: Z

3. Confirmation of standard ball screw

Giving consideration to delivery time and price, select a standard ball screw.

At the primary selection of C3 grade is not found in the standard ball screws. Let us check for application-oriented ball screws whether there is a C3 grade among ball screw.

4. Confirmation of made-to-order ball screw

Because standard ball screws do not meet the accuracy grade requirement, we will consider made-to-order ball screws which are based on standard ball screws but with accuracy grade of C3.

Second selection:

- Made-to-order ball screw
- Shaft diameter : 32, 36, 40, 45, 50 mm
- Lead : 8, 10 mm
- Stroke : 1 000 mm
- Accuracy grade : C3
- Axial play : Z

5. Selection of screw shaft diameter, lead, and nut

(1) Dynamic load rating

Obtain required load carrying capacity for each lead through load conditions. From Table 16.2 "Operating conditions" on page B91, calculate the rotation speed N_i as shown in Table 16.3.

$$N_i \geq \frac{V_i}{l}$$

Table 16.3 Load conditions

Operating condition	Axial load (N)	Rotations per minute (min^{-1})		Use time ratio (%)
		$l = 8$	$l = 10$	
Rapid traverse	$F_1 = 2\,354$	$N_1 = 1\,875$	$N_1 = 1\,500$	$t_1 = 30$
Light/medium cutting	$F_2 = 6\,354$	$N_2 = 62.5$	$N_2 = 50$	$t_2 = 50$
Heavy cutting	$F_3 = 10\,354$	$N_3 = 12.5$	$N_3 = 10$	$t_3 = 20$

By using the formulas 11) and 12) on page B53, calculate the mean load F_m and the mean rotational speed N_m as shown below.

$$F_m = \left(\frac{F_1^3 \cdot N_1 \cdot t_1 + F_2^3 \cdot N_2 \cdot t_2 + F_3^3 \cdot N_3 \cdot t_3}{N_1 \cdot t_1 + N_2 \cdot t_2 + N_3 \cdot t_3} \right)^{1/3}$$

$$N_m = \frac{N_1 \cdot t_1 + N_2 \cdot t_2 + N_3 \cdot t_3}{t}$$

Table 16.4 Mean load and mean rotational speed

Lead (mm)	8	10
Mean load F_m (N)	3 122	3 122
Mean rotational speed N_m (min^{-1})	596	477

Required dynamic load rating C_a is:

Using the formulas 8) and 9) on page B53, calculate the required dynamic load rating.

$$C_a \geq (60 N_m \cdot L_i)^{1/3} \cdot F_m \cdot f_w \times 10^{-2} (N)$$

Whereas required life expectancy $L_i = 20\,000$ (h), load coefficient $f_w = 1.2$ (refer to page B53),

$$l = 8 \text{ (mm)} \dots\dots\dots C_a \geq 33\,500 \text{ (N)}$$

$$l = 10 \text{ (mm)} \dots\dots\dots C_a \geq 31\,100 \text{ (N)}$$

(2) Selection of the nut

Due to the requirement on the lost motion, the nut will be selected as follows emphasizing the importance of system rigidity.

Table 16.5 shows the dynamic load rating of each specification.

- Standard nut ball screw, tube type
- Model: ZFT or DFT (pages B439 to B468)
- Number of turns of balls: Select from 2.5 turns 2 circuits or 2.5 turns 3 circuits

From **Table 16.5** select item that meets required dynamic load rating C_a , as follows:

Third selection: In the range surrounded by the dotted lines in **Table 16.5**

Table 16.5 Dynamic load rating of each specification

Screw shaft diameter (mm)	Dynamic load rating C_a : (N)			
	Lead 8 mm		Lead 10 mm	
	2.5 turns 2 circuits	2.5 turns 3 circuits	2.5 turns 2 circuits	2.5 turns 3 circuits
32	31 700	—	46 300	—
36	—	—	49 300	—
40	34 900	—	52 000	—
45	—	—	54 200	76 800
50	38 700	54 900	57 700	81 800

(3) Permissible rotational speed

[1] Critical speed

Check if the rapid traverse speed of 15 000 mm/min (V_{max}) clears the critical speed. Ball screw rotational speed at each lead N is:

$$l = 8 \text{ (mm)} \dots\dots\dots N = 1\,875 \text{ (min}^{-1}\text{)}$$

$$l = 10 \text{ (mm)} \dots\dots\dots N = 1\,500 \text{ (min}^{-1}\text{)}$$

From the formula 7) on page B47, screw shaft root diameter to meet critical speed requirement is:

$$d \geq \frac{N \cdot L_a^2}{f} \times 10^{-7} \text{ (mm)}$$

In this formula, unsupported length L_a is:

$$L_a = \text{Maximum stroke} + \text{nut length}/2 + \text{shaft end extra length} \\ = 1\,000 + 100 + 200 = 1\,300 \text{ (mm)}$$

Supporting condition of the screw shaft is Fixed - Fixed support, and that of the ball nut is Fixed. Therefore, supporting condition is Fixed - Fixed support (Factor $f = 21.9$)

$$l = 8 \text{ (mm)} \dots\dots\dots d_t \geq 14.5 \text{ (mm)}$$

$$l = 10 \text{ (mm)} \dots\dots\dots d_t \geq 11.6 \text{ (mm)}$$

[2] $d \cdot n$ value

From **Table 3.2** on page B50, as the $d \cdot n$ is 70 000 or less, screw shaft diameters to meet the $d \cdot n$ are:

$$d \leq \frac{70\,000}{N} \text{ (mm)}$$

$$l = 8 \text{ (mm)} \dots\dots\dots d \leq 37.3 \text{ (mm)}$$

$$l = 10 \text{ (mm)} \dots\dots\dots d \leq 46.7 \text{ (mm)}$$

Based on nut specifications (pages B439 to B468) select an item that meets screw shaft root diameter (d_t) and screw shaft diameter (d).

* Please consult NSK if the $d \cdot n$ value is necessary to exceed 70 000.

Fourth selection: In the range surrounded by the solid-lines in **Table 16.5**

(4) Rigidity of the ball screw system

Set the lost motion of the ball screw system (screw shaft, nut and support bearings) at 80% of the specified value. Then calculate the system rigidity. The criterion lost motion is:

$$20 \text{ (}\mu\text{m)} \times 0.8 = 16 \text{ (}\mu\text{m)}$$

At this time, the one-way elastic deformation ΔL of the major factors of ball screw system shall be less than the half of above criterion.

$$\Delta L \leq 8 \text{ (}\mu\text{m)}$$

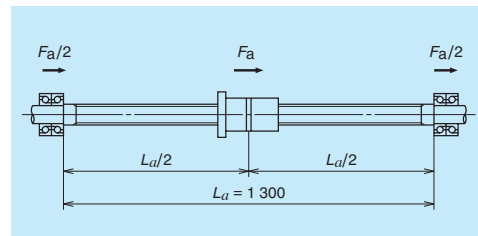

Fig. 16.3 Unsupported length

[1] Rigidity of the screw shaft K_s

Calculate the rigidity at the center of screw shaft where the axial deformation becomes the largest. Because the supporting condition of screw shaft is Fixed - Fixed support, the rigidity as per the formula 21) on page B58:

$$K_s = \frac{\pi \cdot d_t^2 \cdot E}{L_a} \times 10^{-3} \text{ (N/mm)}$$

At here E is the elastic modulus. From the formula 17) on page B57, the elastic deformation of the screw shaft ΔL_s is:

$$\Delta L_s = \frac{F_a}{K_s} = \frac{F_a \cdot L_a}{\pi \cdot d_t^2 \cdot E} \times 10^3 \text{ (}\mu\text{m)}$$

The sliding resistance F_a is:

$$F_a = \mu (m_1 + m_2) = 0.15 \times (1\,000 + 600) \\ = 2\,354 \text{ (N)}$$

Table 16.7 shows the rigidity of screw shaft K_s and the elastic deformation ΔL_s .

[2] Rigidity of the ball nut K_N

Set about 1/3 of the maximum axial load as the preload value F_{a0} .

$$F_{a0} = \frac{F_{max}}{3} = \frac{10\,354}{3} = 3\,452 \rightarrow 3\,500 \text{ (N)}$$

From the formula 23) on page B60, the rigidity of the ball nut K_N is:

$$K_N = 0.8 \times K \left(\frac{F_{a0}}{\epsilon \cdot C_a} \right)^{1/3} = 0.8 \times K \left(\frac{3\,500}{0.1 \cdot C_a} \right)^{1/3} \text{ (N/}\mu\text{m)}$$

K : Theoretical rigidity

From the formula 17) on page B58, elastic deformation of the ball nut ΔL_N is:

$$\Delta L_N = \frac{F_a}{K_N} = \frac{2\,354}{K_N}$$

Table 16.7 shows the rigidity of ball nut K_N and the elastic deformation ΔL_N .

[3] Rigidity of the support bearing K_B

The bearings are Ball screw support bearings NSK TAC C series. We specify the model number of support bearing unit for each shaft diameter as shown in **Table 16.6** (refer to page B415).

Table 16.6 Bearing code

Screw shaft diameter (mm)	Bearing code
32	25TAC62CDF
36	25TAC62CDF
40	30TAC62CDF
45	35TAC72CDF

Refer to page B422 for the rigidity K_B of each bearing unit (axial spring modulus). Elastic deformation of bearing ΔL_B is:

$$\Delta L_B = \frac{F_a}{2K_B}$$

Table 16.7 shows the rigidity of support bearing K_B and the elastic deformation ΔL_B .

Table 16.7 Rigidity and elastic deformation

Nut model number	Screw shaft		Nut		Support bearing		Total ΔL
	K_s	ΔL_s	K_N	ΔL_N	K_B	ΔL_B	
DFT3210-5	347	6.8	839	2.8	850	1.4	11.0
DFT3610-5	460	5.1	907	2.6			9.1
DFT4010-5	589	4.0	973	2.4	1 030	1.1	7.7
DFT4510-5	772	3.0	1 050	2.2			6.3
DFT4510-7.5			1 375	1.7			5.8

Choose the most economical ball screw system which meets the requirement of one-way deformation (ΔL) of 8 μ m or less.

The selected ball screw:
 Nut model number: DFT4010-5
 Shaft diameter: 40 (mm)
 Lead: 10 (mm)
 Dynamic load rating: 52 000 (N)

6. Decision of screw shaft length

DFT4010-5 ball nut has the length of 193 mm, and thus the unsupported length of screw shaft L_a should be:

$$L_a = \text{Maximum stroke} + \text{nut length} + \text{margin} \\ = 1\,000 + 193 + 100 = 1\,293 \rightarrow 1\,300 \text{ mm}$$

7. Checking basic safety

(1) Permissible axial load

Calculate the buckling load for conditions shown in Fig. 16.4 with P of 10 354 (N) and L₁ of 1 210 (mm).

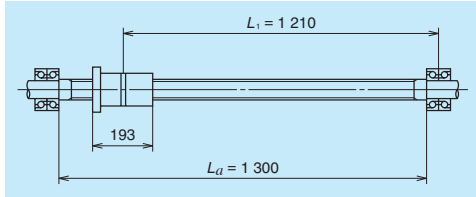

Fig. 16.4 Examination of buckling load

Supporting condition is Fixed - Fixed support, and from the calculation formula 2) on page B44, the screw shaft diameter d, to prevent buckling is

$$d_s \geq \left(\frac{P \cdot L_1^2}{m} \times 10^4 \right)^{1/4}$$

$$= \left(\frac{10\,354 \times 1210^2}{19.9} \times 10^4 \right)^{1/4} = 16.6 \text{ (mm)}$$

From the specification of DFT4010-5 ball nut (page B457), the root diameter of screw shaft d, is 34.4 mm and thus meets the above condition.

Result: Acceptable

(2) Permissible rotational speed

[1] Critical speed n

From the critical speed calculation formula 7) on page B47:

$$n = f \cdot \frac{d_s}{L_1^2} \times 10^7 = 21.9 \times \frac{34.4}{1\,210^2} \times 10^7$$

$$\cong 5\,140$$

The maximum rotational speed (N_{max}) of 1 500 min⁻¹ is less than the critical speed, and thus meets the requirement.

Result: Acceptable

[2] d · n value

The d · n value is:

$$d \cdot n = 40 \times 1\,500 = 60\,000$$

From Table 3.2 on page B50, the d-n of tube type ball nut is 70 000 or less, and meets the requirement.

Result: Acceptable

(3) Life L_t

The dynamic load rating C_a is 52 000 N (see dimension table on page B457), and from the formulas 8) and 9) on page B53 the life expectancy is:

$$L_t = \left(\frac{C_a}{f_w \cdot F_m} \right)^3 \times 10^6 \times \frac{1}{60 \cdot N_m}$$

$$\cong 95\,000$$

The above result satisfies the required life of 20 000 (h).

Result: Acceptable

8. Check whether the following factors satisfy requirements

(1) Checking accuracy

[1] Positioning accuracy

The positioning accuracy of ±0.035/1 000 mm, and therefore, from Table 1.2 "Tolerance of specified travel and travel variation" on page B38 the positioning accuracy is:

Accuracy grade : C3

$$e_p = \pm 0.029/1\,600 \text{ (mm)}$$

$$v_u = 0.018 \text{ (mm)}$$

and thus meets the required positioning accuracy.

[2] Measures against thermal expansion

Provide pre-tension force equivalent to the elongation of 3°C temperature rise, taking in consideration of the load carrying capacity of bearings. Also, adjust the travel compensation for the specified travel equivalent to 3°C temperature rise (refer to page B40).

(a) Thermal elongation : ΔL₀

From the formula 1) on page B40:

$$\Delta L_0 = \rho \cdot \theta \cdot L_0 = 12.0 \times 10^{-6} \times 3 \times 1\,300$$

$$= 0.047 \text{ (mm)}$$

(b) Pre-tension force : F₀

$$F_0 = \Delta L_0 \cdot K_S = \frac{\Delta L_0 \cdot E \cdot \pi \cdot d_s^2}{4L_0}$$

$$= \frac{0.047 \times 2.06 \times 10^5 \times \pi \times 34.4^2}{4 \times 1\,300}$$

$$\cong 6\,922 \rightarrow 6\,900 \text{ (N)}$$

Travel compensation : -0.047/1 300 (mm)

Pre-tension force : 6 900 (N)

Tension (elongation) volume : 0.047 (mm)

[3] Selection of support bearing

Assuming that the ratio of basic dynamic load rating of support bearing (C_a) and pre-tension force (F₀) is ε, select a bearing which generally satisfies the following:

$$\epsilon = F_0/C_a < 0.20$$

Design the bearing supporting configuration to which pre-tension force is applied in such way that the axial load is supported by the duplex combination or a more multiple condition. Please consult NSK when one bearing must sustain the pre-tension load.

Table 16.8 Comparison of dynamic load rating and pre-tension force

Bearing reference number	C _a (N)	ε
30TAC62CDF	29 200	0.23
30TAC62CDFD	47 500	0.14

Selected support bearing: 30TAC62CDFD

(2) Checking drive torque of motor

⟨Required specifications⟩

- Motor rotational speed: 1 500 min⁻¹
- Time to reach maximum speed: 0.16 sec or less (At the time of rapid traverse)

[1] Load (converted to the motor load)

Calculate the moment of inertia of ball screw. From the formulas 30) and 31) on page B64, moment of inertia of ball screw parts J are calculated the load as follows, whereas γ is material density and ball screw shaft length L₀ is 1 550 mm.

(Screw shaft)

$$J_B = \frac{\pi \cdot \gamma}{32} D^4 \cdot L_0 = \frac{\pi \times 7.8 \times 10^3}{32} \times 4^4 \times 155$$

$$= 30 \text{ (kg} \cdot \text{cm}^2)$$

(Moving part)

$$J_w = m \times \left(\frac{l}{2\pi} \right)^2 = 1\,600 \times \left(\frac{1}{2\pi} \right)^2$$

$$= 40 \text{ (kg} \cdot \text{cm}^2)$$

(Coupling)

$$J_c = 10 \text{ (kg} \cdot \text{cm}^2) \text{ ···assumed}$$

(Total)

$$J_L = J_B + J_w + J_c = 30 + 40 + 10$$

$$= 80 \text{ (kg} \cdot \text{cm}^2) \rightarrow 80 \times 10^{-4} \text{ (kg} \cdot \text{m}^2)$$

[2] Driving torque

The required torque to drive a ball screw resisting to external loads T₁ can be obtained by the formula 28) on page B64:

$$T_1 = T_A + T_p + T_U$$

In this formula, T_A is drive torque at constant speed, T_p is dynamic friction torque, and T_U is friction torque of the support bearings. From the formula 26) and 25) on page B63, T_A and T_p are:

$$T_A = \frac{F_a \cdot l}{2\pi \eta_1}$$

$$T_p = 0.014 F_{a0} \sqrt{d_m \cdot l}$$

$$\eta_1 = 0.9$$

Refer to the starting torque value in Table on page B422:

T_U is:

$$T_U = (16 \times 1.35) + (16 \times 1.35) = 43.2 \text{ (N} \cdot \text{cm)}$$

So, the required drive torque during rapid traverse T₁₁ and heavy cutting T₁₃ are:

(At the time of rapid traverse)

$$T_{11} = T_{A1} + T_{p1} + T_U$$

$$= \frac{2\,354 \times 1}{2\pi \times 0.9} + 0.014 \times 3\,500 \sqrt{4.1 \times 1} + 43.2$$

$$= 559 \text{ (N} \cdot \text{cm)} \rightarrow 559 \times 10^{-2} \text{ (N} \cdot \text{m)}$$

(At the time of heavy cutting)

$$T_{12} = T_{A2} + T_{p2} + T_U$$

$$= \frac{10\,354 \times 1}{2\pi \times 0.9} + 0.014 \times 3\,500 \sqrt{4.1 \times 1} + 43.2$$

$$= 1\,973 \text{ (N} \cdot \text{cm)} \rightarrow 1\,973 \times 10^{-2} \text{ (N} \cdot \text{m)}$$

[3] Selection of the motor

⟨Selection conditions⟩

Maximum rotational speed: N_M ≥ 1 500 (min⁻¹)

Motor rating torque: T_M > T₁ (N · m)

Moment of inertia of the motor: J_M > J_L/3 (kg · m²)

Based on the above, select AC servo motor as follows.

Motor specifications	
Rating power output:	$W_M = 1.8$ (kW)
Maximum rotational speed:	$N_M = 1\ 500$ (min ⁻¹)
Rating torque:	$T_M = 22.5$ (N · m) = 22.5×10^2 (N · cm)
Moment of inertia:	$J_M = 190 \times 10^{-4}$ (kg · m ²) = 190 (kg · cm ²)

[4] Checking the time to reach maximum speed:
Required time to reach rapid traverse speed can be calculated as follows (whereas $T_M' = 2 \times T_M$):

$$t_a = \frac{(J_L + J_M) \times 2\pi \times N}{(T_M' - T_L) \times 60} \times 1.4$$

$$= \frac{(80 \times 10^{-4} + 190 \times 10^{-4}) \times 2\pi \times 1\ 500}{(2 \times 22.5 - 559 \times 10^{-2}) \times 60} \times 1.4$$

$$= 0.15 \text{ (sec)}$$

Thus the time meets the requirement 0.16 sec or less.

Drill 3: Cartesian type robot Z axis (vertical axis)

1. Design conditions

Mass of the traveling item :	$m = 300$ kg
Maximum travel :	$S_{\max} = 1\ 500$ mm
Rapid traverse speed :	$V_{\max} = 10\ 000$ mm/min
Repeatability :	0.3 mm
Required life :	$L_t = 24\ 000$ h ($16^{\text{hours}} \times 300^{\text{days}} \times 5^{\text{years}}$)

Screw shaft supporting condition :

Nut:	Fixed -- Simple support
Guide way (rolling) :	Flanged single nut
Drive motor :	$\mu = 0.01$ (friction coefficient)
Environment :	AC servo motor ($N_{\max} = 1\ 000$ min ⁻¹) Slightly dusty

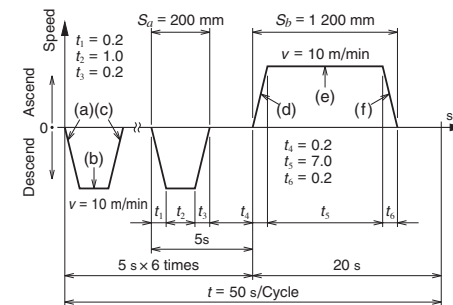

Fig. 16.6 Operating condition

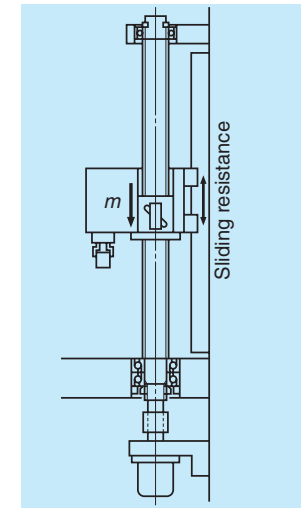

Fig. 16.5 System appearance

2. Selection of basic factors

(1) Selection of accuracy grade

Although this application is not listed in **Table 4.1** "Accuracy grades of ball screw and their application" on page B19, the possibility is to use a ball screw for transfer equipment R series, because the required repeatability is 0.3 mm that is not very high.

(2) Selection of lead

From the maximum rotational speed of AC motor:

$$l \geq \frac{V_{\max}}{N_{\max}} = \frac{10\ 000}{1\ 000} = 10 \text{ (mm)}$$

Select a lead 10 mm or over.

(3) Selection of screw shaft diameter

According to the **Table 4.6** "Shaft diameter, lead and standard screw length of R Series" on page B23, the shaft diameters whose lead is 10 mm or over are in the range of 12 mm to 50 mm.

(4) Selection of stroke

From the **Table 4.6** "Screw shaft diameter, lead and standard screw shaft length of R series" on page B23, it is possible to select from R series because the diameter d of 15 mm to 50 mm and lead l of 10 mm will meet the required maximum stroke of 1500 mm.

Primary selection : R Series ball screw for transfer equipment
 Screw shaft diameter : 15 – 50 (mm)
 Lead : 10 (mm)
 Stroke : 1 500 (mm)

3. Confirmation of standard ball screw

Select from a flanged single nuts of R Series ball screws for transfer equipment.

Second selection : R Series ball screw for transfer equipment
 Screw shaft diameter : 16, 20, 25, 32, 36
 40, 45, 50 (mm)
 Lead : 10 (mm)
 Stroke : 1 500 (mm)

4. Decision of screw length

Screw length L_o is:

$$L_o = \text{Stroke} + \text{nut length} + \text{margin} + \text{shaft end length}$$

$$= 1\,500 + 100 + 100 + 200 = 1\,900 \text{ (mm)}$$

Normally, the overall screw shaft length L_o less than or equal to 70 times of screw shaft diameter d is recommended.

Therefore, screw shaft diameter d is:

$$d \geq \frac{L_o}{70} = \frac{1\,900}{70} = 27.1 \text{ (mm)}$$

Third selection : R Series ball screw for transfer equipment
 Shaft diameter: 32, 36, 40, 45, 50 (mm)
 Lead: 10 (mm)
 Stroke: 1 500 (mm)

5. Checking basic safety

(1) Allowable axial load

[1] Calculation of allowable axial load
 Accelerating/decelerating time is:

$$\alpha = \frac{V}{60 t} = \frac{10 \times 10^3}{60 \times 0.2} = 833 \text{ (mm/s}^2\text{)}$$

$$= 0.833 \text{ (m/s}^2\text{)}$$

$$t = t_1 = t_3 = t_4 = t_6$$

(a), (f) $\dots\dots F_1 = mg - m\alpha$
 $= 300 \times 9.80665 - 300 \times 0.833$
 $= 2\,690 \text{ (N)}$

(b), (e) $\dots\dots F_2 = mg = 2\,940 \text{ (N)}$

(c), (d) $\dots\dots F_3 = mg + m\alpha = 3\,190 \text{ (N)}$

[2] Buckling load

For condition in Fig. 16.7, use values below.

$P = 3\,190 \text{ N}, L_1 = 1\,600 \text{ mm}$

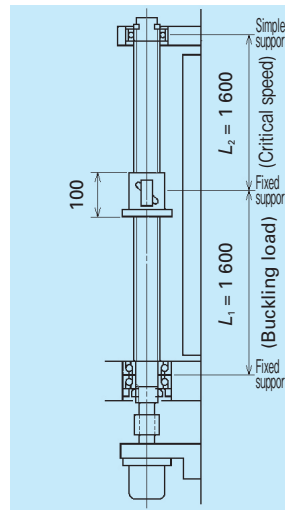

Fig. 16.7 Inspecting for buckling load and critical speed

From the formula 2) on page B44:

$$d_i \geq \left(\frac{P \cdot L_1^2}{m} \times 10^{-4} \right)^{1/4}$$

$$= \left(\frac{3\,190 \times 1\,600^2}{19.9} \times 10^{-4} \right)^{1/4} = 14.2 \text{ (mm)}$$

(2) Checking permissible rotational speed

[1] Critical speed

Use values below.

$n = 1\,000 \text{ (min}^{-1}\text{)}, L_2 = 1\,600 \text{ (mm)}$

From the formula 7) on page B47:

$$d_i \geq \frac{n \cdot L_2^2}{f} \times 10^{-7} = \frac{1\,000 \times 1\,600^2}{15.1} \times 10^{-7}$$

$$= 17 \text{ (mm)}$$

[2] $d \cdot n$ value

From Table 3.2 on page B50:

$$d \leq \frac{50\,000}{n} = \frac{50\,000}{1\,000}$$

$$= 50 \text{ (mm)}$$

* Please consult NSK when the $d \cdot n$ value exceeds 50 000.

(3) Checking life (dynamic load rating)

Determine the required load carrying capacity from load conditions of Table 16.9.

Table 16.9 Load conditions

Operating condition	Axial load (N)	Rotational speed (mean) (min ⁻¹)	Use time (s)
(a) _{xe} (f)	$F_1 = 2\,690$	$N_1 = 500$	$t_a = 1.4$
(b) _{xe} (e)	$F_2 = 2\,940$	$N_2 = 1\,000$	$t_b = 13.0$
(c) _{xe} (d)	$F_3 = 3\,190$	$N_3 = 500$	$t_c = 1.4$

Calculate mean load F_m and mean rotational speed N_m from the formulas 11) and 12) on page B53:

Required load carrying capacity is:

$$F_m = \left(\frac{F_1^3 \cdot N_1 \cdot t_a + F_2^3 \cdot N_2 \cdot t_b + F_3^3 \cdot N_3 \cdot t_c}{N_1 \cdot t_a + N_2 \cdot t_b + N_3 \cdot t_c} \right)^{1/3}$$

$$= 2\,940 \text{ (N)}$$

$$N_m = \frac{N_1 \cdot t_a + N_2 \cdot t_b + N_3 \cdot t_c}{t}$$

$$= 288 \text{ (min}^{-1}\text{)}$$

From the formulas 8) and 9) on page B53:

$$C_a \geq (60 N_m \cdot L_1)^{1/3} \cdot F_m \cdot f_w \times 10^{-2} \text{ (N)}$$

$$= (60 \times 288 \times 24\,000)^{1/3} \times 2\,940 \times 1.2 \times 10^{-2}$$

$$= 26\,300 \text{ (N)}$$

(4) Checking static load rating

$$C_{0a} = F_{\max} \times f_s = 3\,190 \times 2$$

$$= 6\,380 \text{ (N)}$$

In consideration of expense, select a ball screw shaft as follows.

Fourth selection : R Series ball screw for transfer equipment

Shaft diameter : 32 (mm)
 Lead : 10 (mm)
 Stroke :
 Turns of balls and circuit number : 2.5 × 2
 Screw length : 2 000 (mm)
 Basic dynamic load rating : 35 700 (N)

6. Selection of nut

Select a "standard nut with a flange and a built-in brush seals" based on the environmental conditions.

Selected ball screw:

Nut assembly RNFTL3210A5S
 Screw shaft RS3210A20

B-2-18 Reference

"NSK Motion & Control (technical journal)" was compiled to introduce NSK products and its technologies. You will find data summaries which are imperative in selecting ball screws in this catalog. If you need detailed technical data, other than described in this catalog, please refer

to "NSK Motion & Control" technical journal. For inquiries and orders, please contact NSK branch offices, sales offices, and representatives assigned at various locations.

Table 17.1 NSK Motion & Control (technical journal) : Issues relating to ball screws (1980-)

Issue No.	Date of Publication	Articles related to Ball Screws
No.4	Jun. 1998	Recent Technical Trends in Ball Screws
No.8	May. 2000	Ball Screw with Rotating Nut and Vibration Damper
No.9	Oct. 2000	WFA Standard-Stock Ball Screws
No.10	Apr. 2001	High Performance Seals for Ball Screws
No.11	Oct. 2001	Development of NSK S1 Series Ball Screws and Linear Guides
No.11	Oct. 2001	Low Inertia Series of Nut Rotatable Ball Screws
No.13	Oct. 2002	Development of HTF Series Ball Screws for High Load Drive Application
No.13	Oct. 2002	High Lead Precision Rolled Ball Screws
No.14	May. 2003	High Speed and Low Noise Ball Screws HMC-B02 Series
No.15	Dec. 2003	Clean Support Units for Ball Screws
No.16	Aug. 2004	Development of High Speed and Low Noise Ball Screws
No.18	Aug. 2005	S3 Ball Screws: Super Low Noise Ball Screws for Automation Equipment
No.19	Sep. 2006	High-Speed and Low-Noise Ball Screw for Standard Stock - Compact FA Series
No.21	Dec. 2007	V1 Series of Ball Screws for Contaminated Environments HTF-SRC Series of Ball Screws for High-Speed and High-Load Applications
No.22	Mar. 2011	Technological Trends of Ball Screws for Industrial Machinery BSL Series of Ball Screws for Small Lathes HTF-SRD Series of Long-Lead Ball Screws for High-Speed and Heavy-Load Applications
No.23	Jun. 2013	TW Series of Ball Screws for Twin-Drive Systems HMD Series of Ball Screws for High-Speed Machine Tools
No.24	Dec. 2014	Ball Screw for Motorcycle Brake Systems
No.25	Sep. 2015	HMS Series of Ball Screws for High-Speed Machine Tools Miniature Large-Lead Series of High-Speed, Low-Noise Ball Screws
No.26	Apr. 2016	Development of a Nut Cooling Ball Screw Ball Screws with X1 Seals for Machine-Tool Applications HTF-SRE Large, High-Speed, High-Load Capacity Ball Screws
No.27	Nov. 2016	Strategy for Frictional Behavior Control in Ball Screws Ball Screws with Minimal Grease-Splatter L1 Seals
No.28	Jun. 2017	Ultra-Large Ball Screws

B-2-19 Guide to Technical Services

(1) CAD data

■Web page

<http://www.jp.nsk.com/app01/en/ctr/>

■CD-ROM

CAT. No. 7110

(3D data: Intermediate format or native,

2D date: DXF)

Catalog No.7110 (CD-ROM) contains precision machine components and rolling bearings.

Standard Ball Screws

- Finished shaft end (Compact FA series, MA type, FA type, SA type, KA type, and RMA type)
- Blank shaft end (MS type, FS type, and SS type)

Standard nut ball screws

- End deflector type

Standard support units

(2) Telephone consultation with NSK engineers

This catalog contains technical explanation for each section. However, some descriptions and explanations may be insufficient due to page limitation, etc. To amend this shortcoming, NSK offers telephone assistance. NSK engineers are pleased to help you. Our local offices are listed in the last part of this catalog. Call local NSK office or representative in your area.

(3) Additional machining (processing) some part of standard ball screws in stock

NSK processes standard ball screw blank shaft end. NSK also cuts linear guide rails to required length for you. Service is available at NSK processing factories throughout the world. Requests are taken by branch offices and agencies.

B-2-20 Precautions When Handling Ball Screws

Ball screws are precision products. They require careful handling as described below.



Confirm lubrication

Lubrication

(1) Confirm the state of lubrication before use. Insufficient lubrication causes loss of ball screw functions in a short period.

(2) Do not apply any lubrication if grease is already applied to the ball screws. Remove dust or swarf if they stuck to the greased surface during handling. Wipe the surface with clean white kerosene, and then apply the same type of new lubricant before use. Avoid using different types of grease at the same time.

Consult NSK for special oil lubricant if it is required to your application.

(3) Check the grease after two to three months of operation. Wipe off the old grease if it is excessively contaminated, and apply sufficient volume of a fresh coat of grease. After the initial check, check and replenish the grease approximately every year. Check more often if environment requires.

Note: Refer to pages B67 and D13 for lubrication.



Do not disassemble



Do not reassemble



Watch out for falling objects



Handle with care



Do not apply shock

Handling

(1) Never disassemble the ball screw. It invites dust to enter, and lowers precision, or may cause an accident.

(2) Once the ball screw is disassembled for some reason, the user should never reassemble the ball screw by himself. Loss of ball screw function is apt to occur if a mistake is made. Please send the ball screw to NSK for repair or re-assembly. It will be reworked at the minimum service charge.

(3) The ball screw shaft or nut may fall off due to its own weight. Watch out for such falling object. If it falls, the ball groove or ball recirculation component may be damaged and their function might be lost. Make certain to return such item to NSK for check. There will be the minimum charge for this service.

(4) If the recirculation component, the shaft outside, or the ball groove is scratched or damaged by impact, recirculation operation becomes deficient, and may cause a loss of function.

Note: Refer to page B73 for assembling components.



Prevent dust



Rotational speed limitation



Do not overrun



Temperature limitation

Precautions in use

(1) Ball screws should be used in a clean environment. Use a dust cover to keep dust and swarf from entering into the system. Insufficient dust protection causes not only the ball screw function to deteriorate but also brings about damage to the recirculation components if dust plugs the system. This may result in more serious accident such as a fall of the table.

(2) For rotational speed in operation, refer to the applicable section in this catalog which describes permissible rotational speeds, or to specification drawing furnished by NSK. Exceeding permissible rotational speed damages recirculation components, and may cause the table to fall. A precaution system such as a safety nut is recommended in vertical use of ball screw. Please consult NSK for safety system.

(3) Overrunning ball nut (removed from the ball thread) causes the balls to fall out, damages recirculation components, and dent ball groove, resulting in insufficient operation. Continued use under such conditions may cause premature wear, and damages recirculation components. For these reasons, avoid overrun by all means. If overrun occurs, please request NSK to check. There will be a minimum charge for this service.

(4) Ball screws are designed to be used at a temperature of less than 80°C. Do not operate at temperatures higher than this limit. Use at a higher temperature may damage recirculation and seal components. Please consult NSK if it is necessary to use at a temperature higher than the limit.

When using NSK K1 lubrication unit, the operating temperature should be 50°C or less. (Momentary maximum temperature in use: 80°C)

Note: Please read page B83 before designing.



Store in the correct position

Storage

(1) Store in the original NSK package. Do not unwrap or tear the inner wrapping if it is not necessary. This allows dust to enter and rust to set in, and may deteriorate functions.

(2) The following position is recommended when storing ball screws.

- ① Keep in the NSK original package, and place it flat.
- ② Place flatly on supports; store in a clean area.
- ③ Hang vertically in a clean place.

B-3 Ball Screw Dimension Table

1. Compact FA Series	B107
2. High-Speed SS Series	B147
3. Finished Shaft End	B157
MA Type, Miniature, Fine Lead	B159
FA Type for Small Equipment	B181
SA Type for Machine Tools	B217
4. Finished Shaft End	
KA Type Stainless Steel Product	B273
5. Blank Shaft End	B299
MS Type, Miniature, Fine Lead	B301
FS Type for Small Equipment	B309
SS Type for Machine Tools	B321
6. Ball Screws for Transfer Equipment	B349
7. Accessories	B389

B-3-1 Dimension Table and Reference Number of Standard Ball Screws

B-3-1.1 Compact FA Series PSS Type, USS Type, and FSS Type

1. Features

In order to respond quickly to a wide range of needs, NSK keeps end-deflector recirculation system ball screws, which offer high-speed and low-noise operation and compact design, in standard inventories as the Compact FA Series. The exceptionally high performance ball screws are ready for use in a variety of fields such as semiconductor manufacturing equipment, LCD manufacturing equipment, chip mounting equipment, measuring apparatus, food and medical equipment, and automotive manufacturing equipment.

●Quieter sound

The operating noise level of ball screws has been reduced by 6 dB, about half of what is sensed by the ear.

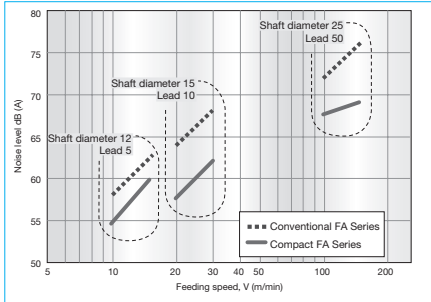

(Microphone was positioned at a distance of 400 mm for all noise levels)

Fig. 1 Comparison of noise level

●Compact

The outside diameter of the ball nut is as much as 30% smaller than those of existing NSK products. This contributes to more compact design of all sorts of equipment and devices such as low-profile positioning stages.

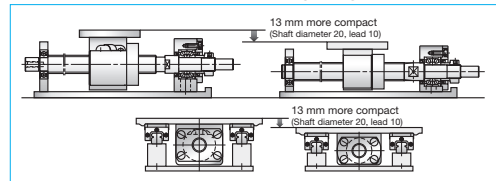

Fig. 2 Comparison of FA Type and Compact FA Series PSS Type

●High speed

The permissible rotational speed up to 5 000 min⁻¹. This capability dramatically expands the range of service conditions. Please refer to the dimension tables for details of the permissible rotational speed.

●A grease fitting is provided as a standard equipment
The new ball screw type is equipped with a grease fitting (M5 × 0.8) as a standard equipment. Two lubrication ports are provided to facilitate easy maintenance.

●Storage seal

Compact, thin plastic seal is available. Nut outside diameter is compact compare with the return tube recirculation system.

●Low-profile design

The low-profile support units especially compatible with the compact FA Series are available for a superb space-saving design.

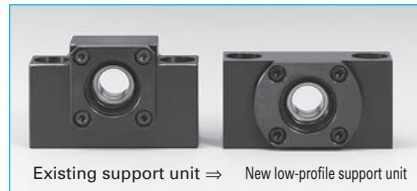

Fig. 3 Comparison of support units

●Low dust generation LG2 grease (USS Type)

The dust count is approximately 1/100 that of the existing FA series. It is suitable for applications in clean environments.

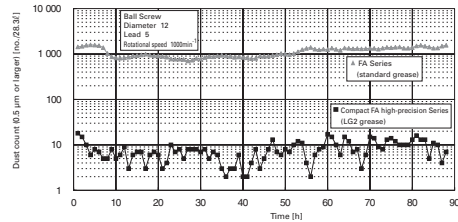
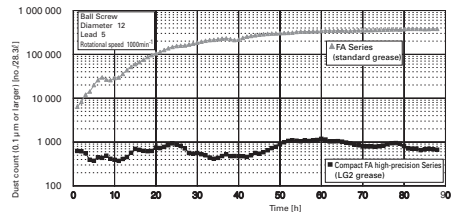

Fig.4 Comparison of dust count

●Easy stroke setting (FSS Type)

Flexible stroke setting with fixed-simple support by means of mounting support unit (simple support side) directly onto ball screw thread outside diameter. Proprietary support unit (simple support side) is available from NSK.

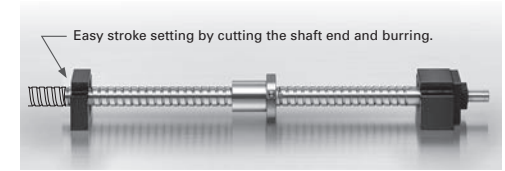

Fig.5 Flexible stroke setting

2. Order of the dimension table

For each type, it is arranged in order from small diameter to large.

3. Dimension tables

Dimension tables show shapes/sizes as well as specification factors of each shaft diameter/lead combination. Tables also contain data as follows:

●Stroke

Nominal stroke: A reference for your use.
Maximum stroke: The limit stroke that the nut can move. The figure is obtained by subtracting the nut length from the effective threaded length (L₁).

●Lead accuracy

PSS Type, C5 grade; USS Type, C3 grade; FSS Type, Ct7 grade

T: Travel compensation

e_p: Tolerance on specified travel

v_u: Travel variation

See "Technical Description: Lead Accuracy" (page B37) for the details of the codes.

●Permissible rotational speed

d · n: Limited by the relative peripheral speed between the screw shaft and the nut.

Critical speed: Limited by the natural frequency of a ball screw shaft. Critical speed depends on the supporting condition of screw shaft.

The lower of the two criteria, the d · n and critical speed, will determine the overall permissible rotational speed of the ball screw. For details, see "Technical Description: Permissible Rotational Speed" (page B47).

4. Other

The seal of the ball screw and end deflector are made of synthetic resin. Consult NSK when using our ball screws under extreme environments or in special environments, or if using special lubricant or oil.

The NSK K1 cannot be mounted to the compact FA Series.

For special environments, see pages B70 and D2. For lubrications, see pages B67 and D13.

Note: For details of standard stock products, contact NSK.

Table 1 Combinations of screw shaft diameter and lead

Screw shaft diameter	Lead											
	5	8	10	12	15	20	25	30	40	50	60	
6		B109		B109								
8					B111							
10	B113 B133		B113									
12	B115 B135		B115 B139			B115		B115				
15	B117 B137		B117 B141			B119 B141		B119				
20	B121		B121 B143			B123 B143		B123	B125		B125	
25	B127		B127 B145			B129 B145	B129 B145	B131		B131		

Compact FA PSS Type

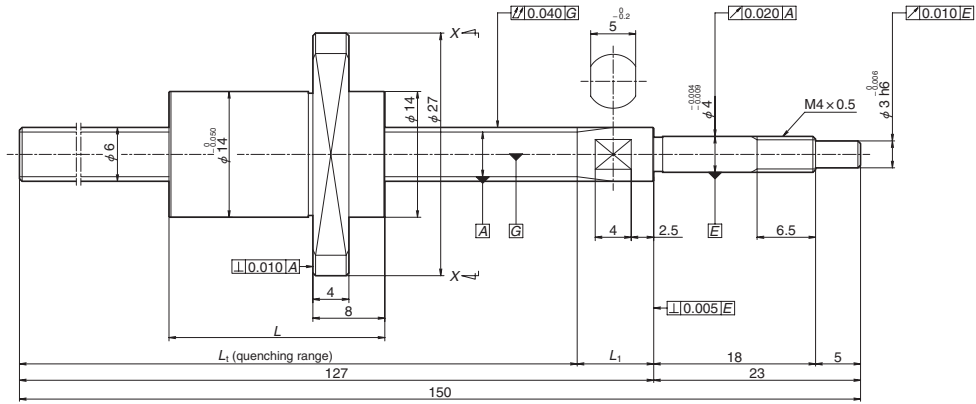

NSK

Screw shaft $\phi 6$

Lead 8, 12

Unit: mm

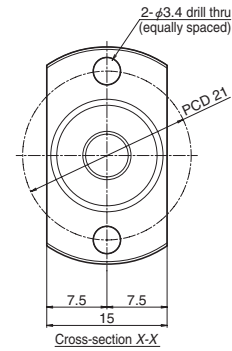

Ball screw specification

Ball diameter/screw shaft root diameter	1.2 / 4.9
Ball circle dia.	6.2
Accuracy grade/axial play	C5 / 0.005 or less
Factory-packed grease	NSK grease PS2

Recommended

For drive side (Fixed)

WBK04-01M (square)
WBK04-11M (round)

Ball screw No.	Screw shaft diameter d	Lead l	Effective turns of balls	Basic load ratings (N)		Maximum stroke	Nut length L	Screw shaft dimensions	
				Dynamic C_a	Static C_{0a}			L_1	L_1
PSS0608NAD0150	6	8	2	550	715	97.5	16	118.5	8.5
PSS0608NBD0150			4	1 180	1 760	89.5	24	118.5	8.5
PSS0612NAD0150		12	2	550	715	92	20	117	10
PSS0612NBD0150			4	1 180	1 760	80	32	117	10

Notes: 1. Contact NSK if permissible rotational speed is to be exceeded.

Lead accuracy			Dynamic preload torque (N·cm)	Mass (kg)	Permissible rotational speed (min ⁻¹) *1	Internal spatial volume of nut (cm ³)	Standard volume of grease replenishing (cm ³)
Target value T	Error e_p	Variation v_u					
0	0.020	0.018	~0.5	0.06	5 000	0.2	0.1
				0.06		0.3	0.2
				0.06		0.2	0.1
				0.07		0.3	0.2

2. Service temperature range is 0 to 80°C.

3. Use of NSK support unit is recommended. Refer to page B389 for details.

Compact FA PSS Type

(Medium, High helix lead)

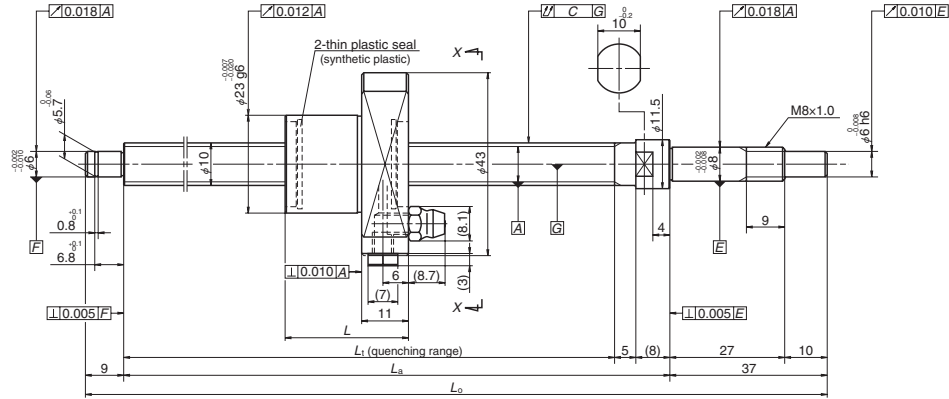

Nut model: BSS

NSK

Screw shaft $\phi 10$

Lead 5, 10

Unit: mm

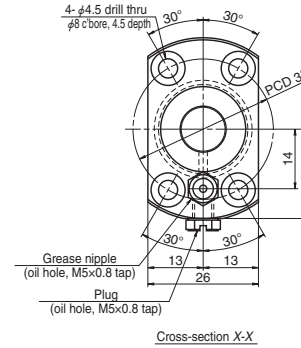

Ball screw specification

Preload type	Oversize ball preload (P-preload)
Ball diameter/screw shaft root diameter	2.000 / 8.2
Ball circle dia.	10.3
Accuracy grade/axial play	C5 / 0
Factory-packed grease	NSK grease PS2

Recommended support unit

For drive side (Fixed)	For opposite to drive side (Simple)
WBK08-01B (low-profile, square)	WBK08S-01B (low-profile, square)
WBK08-11B (round, high load)	

Ball screw No.	Screw shaft diameter d	Lead l	Basic load ratings (N)		Stroke		Nut length L	Screw shaft dimensions		
			Dynamic C_a	Static C_{0a}	Nominal	Max.		L_t	L_a	L_o
PSS1005N1D0171	10	5	2 930	4 790	50	78	29	112	125	171
PSS1005N1D0221					100	128		162	175	221
PSS1005N1D0321					200	228		262	275	321
PSS1005N1D0421					300	328		362	375	421
PSS1005N1D0521		400	428	462	475	521				
PSS1010N1D0221		10	1 970	3 010	100	125	32	162	175	221
PSS1010N1D0321					200	225		262	275	321
PSS1010N1D0421					300	325		362	375	421
PSS1010N1D0521	400				425	462		475	521	

- Notes: 1. Indicates ball screw preload control value. Approximately 2.0 N-cm of torque is added due to thin plastic seals.
 2. Contact NSK if permissible rotational speed is to be exceeded.
 3. Service temperature range is 0 to 80°C.

Lead accuracy			Shaft run-out C	Dynamic preload torque (N-cm) *1	Mass (kg)	Permissible rotational speed (min ⁻¹) *2	Internal spatial volume of nut (cm ³)	Standard volume of grease replenishing (cm ³)
Target value T	Error e_p	Variation v_u						
0	0.020	0.018	0.030	0.7 - 3.3	0.3	5 000	0.8	0.4
	0.020	0.018	0.045	0.7 - 3.3	0.3			
	0.023	0.018	0.060	0.6 - 4.3	0.3			
	0.025	0.020	0.070	0.6 - 4.3	0.4			
	0.027	0.020	0.085	0.4 - 4.9	0.5	5 000	0.7	0.4
	0.020	0.018	0.045	0.7 - 3.3	0.3			
	0.023	0.018	0.060	0.6 - 4.3	0.4			
	0.025	0.020	0.070	0.6 - 4.3	0.4			
0.027	0.020	0.085	0.4 - 4.9	0.5				

4. Use of NSK support unit is recommended. Refer to page B389 for details.
 5. Recommended quantity of grease is about 50% of ball nut's internal space. See page D16 for details.

Compact FA PSS Type

(Fine, Medium, High helix lead)

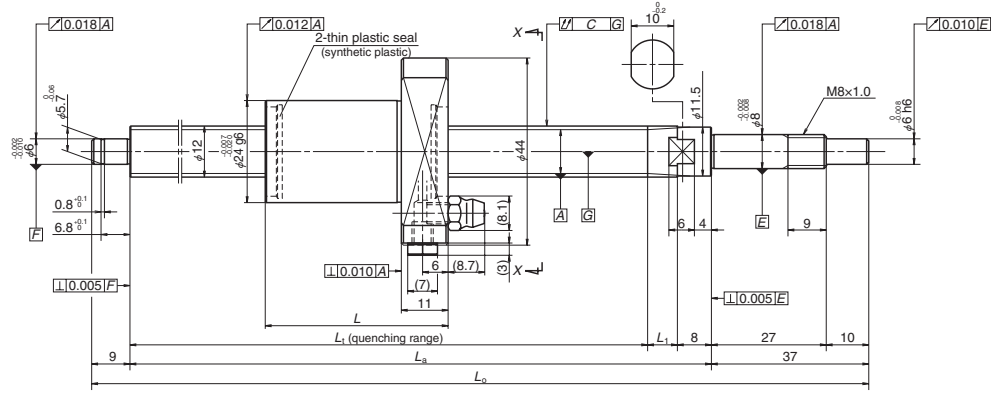

Nut model: BSS



Screw shaft $\phi 12$

Lead 5, 10, 20, 30

Unit: mm

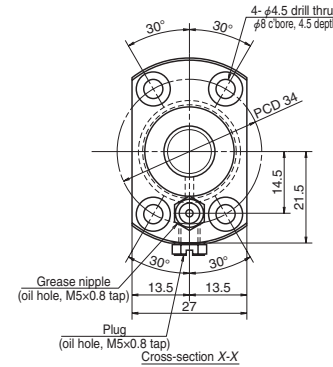

Ball screw specification	
Preload type	Oversize ball preload (P-preload)
Ball diameter/screw shaft root diameter	2.000 / 10.2
Ball circle dia.	12.3
Accuracy grade/axial play	C5 / 0
Factory-packed grease	NSK grease PS2

Recommended support unit	
For drive side (Fixed)	For opposite to drive side (Simple)
WBK08-01B (low-profile, square)	WBK08S-01B (low-profile, square)
WBK08-11B (round, high load)	

Ball screw No.	Screw shaft diameter d	Lead l	Basic load ratings (N)		Stroke		Nut length L	Screw shaft dimensions			
			Dynamic C_a	Static C_{0a}	Nominal	Max.		L_1	L_a	L_b	L_c
PSS1205N1D0171	12	5	3 200	5 860	50	75	30	110	125	171	7
PSS1205N1D0221					100	125		160	175	221	
PSS1205N1D0321					200	225		260	275	321	
PSS1205N1D0421					300	325		360	375	421	
PSS1205N1D0521					400	425		460	475	521	
PSS1205N1D0621		500	525	560	575	621					
PSS1210N1D0221		10	3 200	5 860	100	112	43	160	175	221	7
PSS1210N1D0321					200	212		260	275	321	
PSS1210N1D0421					300	312		360	375	421	
PSS1210N1D0521					400	412		460	475	521	
PSS1210N1D0621					500	512		560	575	621	
PSS1220N1D0271		20	2 150	3 610	100	153	50	208	225	271	9
PSS1220N1D0371					200	253		308	325	371	
PSS1220N1D0471					300	353		408	425	471	
PSS1220N1D0571					400	453		508	525	571	
PSS1220N1D0671	500				553	608		625	671		
PSS1230N1D0271	30	2 150	3 610	100	128	70	203	225	271	14	
PSS1230N1D0371				200	228		303	325	371		
PSS1230N1D0471				300	328		403	425	471		
PSS1230N1D0571				400	428		503	525	571		
PSS1230N1D0671				500	528		603	625	671		

- Notes: 1. Indicates ball screw preload control value. Approximately 2.0 N-cm of torque is added due to thin plastic seals.
2. Contact NSK if permissible rotational speed is to be exceeded.
3. Service temperature range is 0 to 80°C.

Target value T	Lead accuracy		Shaft run-out C	Dynamic preload torque (N-cm) ^{*1}	Mass (kg)	Permissible rotational speed (min ⁻¹) ^{*2}	Internal spatial volume of nut (cm ³)	Standard volume of grease replenishing (cm ³)
	Error e_p	Variation v_u						
0	0.020	0.018	0.030	0.7 - 3.3	0.3	5 000	1.0	0.5
	0.020	0.018	0.045	0.7 - 3.3	0.3			
	0.023	0.018	0.060	0.6 - 4.3	0.4			
	0.025	0.020	0.070	0.6 - 4.3	0.5			
	0.027	0.020	0.085	0.6 - 4.3	0.6			
	0.030	0.023	0.085	0.4 - 4.9	0.7			
	0.020	0.018	0.045	0.7 - 3.3	0.4	5 000	1.0	0.5
	0.023	0.018	0.060	0.6 - 4.3	0.5			
	0.025	0.020	0.070	0.6 - 4.3	0.5			
	0.027	0.020	0.085	0.6 - 4.3	0.6			
	0.030	0.023	0.085	0.4 - 4.9	0.7			
	0.023	0.018	0.045	1.4 - 4.5	0.4	5 000	1.2	0.6
	0.023	0.018	0.060	0.9 - 4.9	0.5			
	0.027	0.020	0.070	0.9 - 4.9	0.6			
	0.030	0.023	0.085	0.6 - 5.9	0.7			
0.030	0.023	0.110	0.6 - 5.9	0.8				
0.023	0.018	0.045	1.4 - 4.5	0.5	5 000	1.5	0.8	
0.023	0.018	0.060	0.9 - 4.9	0.6				
0.027	0.020	0.070	0.9 - 4.9	0.7				
0.030	0.023	0.085	0.6 - 5.9	0.7				
0.030	0.023	0.110	0.6 - 5.9	0.8				

4. Use of NSK support unit is recommended. Refer to page B389 for details.
5. Recommended quantity of grease is about 50% of ball nut's internal space. See page D16 for details.

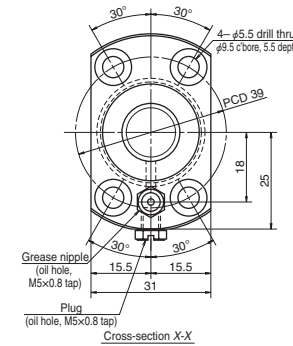
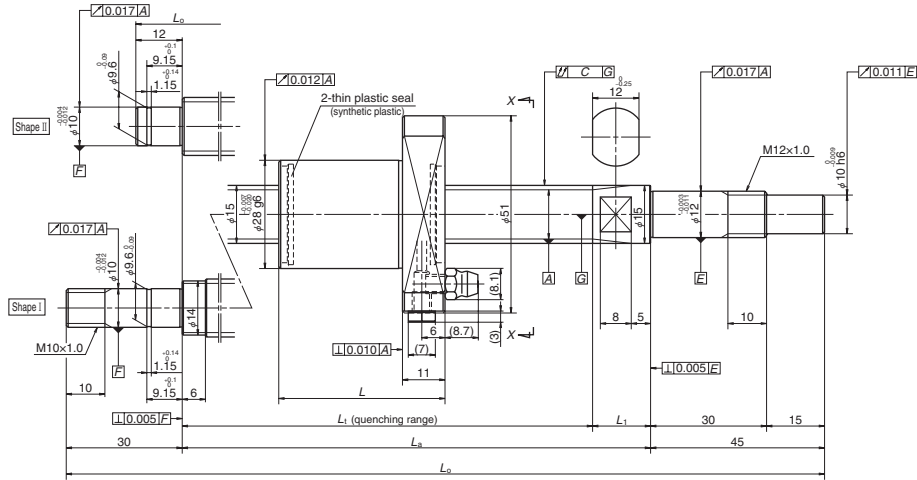

Ball screw specification

Preload type	Oversize ball preload (P-preload)
Ball diameter/screw shaft root diameter	2.778 / 12.6
Ball circle dia.	15.5
Accuracy grade/axial play	C5 / 0
Factory-packed grease	NSK grease LR3

Recommended support unit

For drive side (Fixed)	For opposite to drive side	
	(Fixed)	(Simple)
WBK12-01B (low-profile, square)	WBK10-01B (low-profile, square)	WBK12S-01B (low-profile, square)
WBK12-11 (round)	WBK10-11 (round)	

Ball screw No.	Screw shaft diameter <i>d</i>	Lead <i>l</i>	Basic load ratings (N)		Stroke		Nut length <i>L</i>	Screw shaft dimensions			
			Dynamic <i>C_a</i>	Static <i>C_{0a}</i>	Nominal	Max.		<i>L₁</i>	<i>L_a</i>	<i>L_b</i>	<i>L_c</i>
PSS1505N1D0211	15	5	5 460	10 200	50	103	30	139	154	211	15
PSS1505N1D0261					100	153		189	204	261	
PSS1505N1D0361					200	253		289	304	361	
PSS1505N1D0461					300	353		389	404	461	
PSS1505N1D0561					400	453		489	504	561	
PSS1505N1D0661					500	553		589	604	661	
PSS1505N1D0761					600	653		689	704	761	
PSS1510N1D0261	15	10	5 460	10 200	100	140	43	189	204	261	15
PSS1510N1D0361					200	240		289	304	361	
PSS1510N1D0461					300	340		389	404	461	
PSS1510N1D0561					400	440		489	504	561	
PSS1510N1D0661					500	540		589	604	661	
PSS1510N1D0761					600	640		689	704	761	
PSS1510N1D0879					700	740		789	804	879	
PSS1510N1D0979					800	840		889	904	979	
PSS1510N1D1179					1 000	1 040		1 089	1 104	1 179	

Notes: 1. Indicates ball screw preload control value. Approximately 2.0 N-cm of torque is added due to thin plastic seals.
2. Contact NSK if permissible rotational speed is to be exceeded.
3. Service temperature range is 0 to 80°C.

Left shaft end (opposite driven side)	Lead accuracy			Shaft run-out <i>C</i>	Dynamic preload torque (N-cm) *1	Mass (kg)	Permissible rotational speed (min) ⁻¹ *2		Internal spatial volume of nut (cm ³)	Standard volume of grease replenishing (cm ³)
	Target value <i>T</i>	Error <i>e_p</i>	Variation <i>v_u</i>				Fixed-Simple	Fixed-Fixed		
II	0	0.020	0.018	0.035	0.2 - 6.9	0.5	5 000	2.0	1.0	
		0.020	0.018	0.035	0.2 - 6.9	0.5	5 000			
		0.023	0.018	0.045	0.2 - 6.9	0.6	5 000			
		0.025	0.020	0.050	0.4 - 9.8	0.8	5 000			
		0.027	0.020	0.060	0.4 - 9.8	0.9	5 000			
		0.030	0.023	0.075	0.4 - 9.8	1.0	5 000			
		0.035	0.025	0.075	0.4 - 11.8	1.1	4 130			
II	0	0.020	0.018	0.035	0.6 - 7.4	0.6	5 000	2.0	1.0	
II		0.023	0.018	0.045	0.6 - 7.4	0.7	5 000			
II		0.025	0.020	0.050	0.4 - 9.8	0.8	5 000			
II		0.027	0.020	0.060	0.4 - 9.8	1.0	5 000			
II		0.030	0.023	0.075	0.4 - 9.8	1.1	5 000			
II		0.035	0.025	0.075	0.4 - 11.8	1.2	4 210			
I		0.035	0.025	0.095	0.4 - 11.8	1.4	3 190			4 410
I	0.040	0.027	0.095	0.4 - 11.8	1.5	2 500	3 470			
I	0.046	0.030	0.120	0.4 - 11.8	1.7	1 650	2 320			

4. Use of NSK support unit is recommended. Refer to page B389 for details.
5. Recommended quantity of grease is about 50% of ball nut's internal space. See page D16 for details.

Compact FA PSS Type

(Medium, High helix lead)

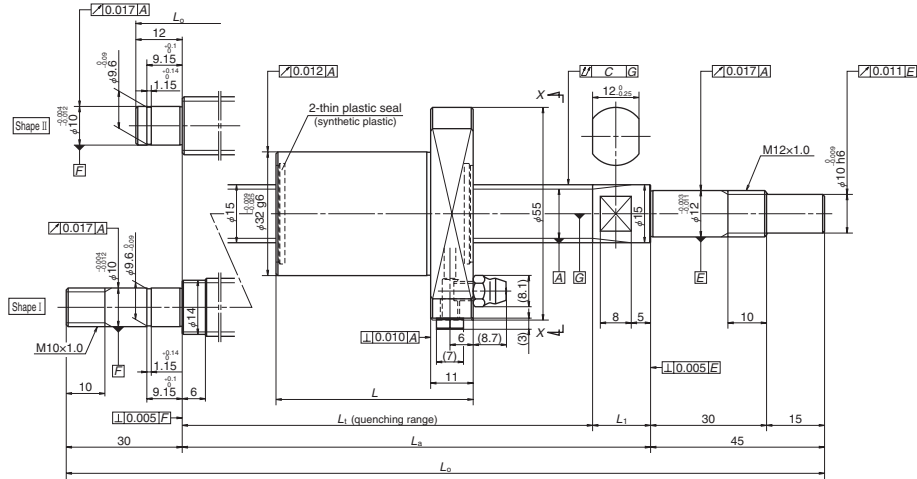

Nut model: BSS

NSK

Screw shaft $\phi 15$

Lead 20, 30

Unit: mm

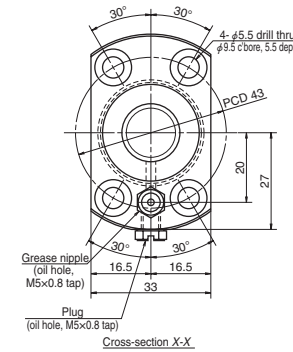

Ball screw specification

Preload type	Oversize ball preload (P-preload)
Ball diameter/screw shaft root diameter	3.175 / 12.2
Ball circle dia.	15.5
Accuracy grade/axial play	C5 / 0
Factory-packed grease	NSK grease LR3

Recommended support unit

For drive side (Fixed)	For opposite to drive side	
	(Fixed)	(Simple)
WBK12-01B (low-profile, square)	WBK10-01B (low-profile, square)	WBK12S-01B (low-profile, square)
WBK12-11 (round)	WBK10-11 (round)	

Unit: mm

Ball screw No.	Screw shaft diameter d	Lead l	Basic load ratings (N)		Stroke		Nut length L	Screw shaft dimensions								
			Dynamic C_a	Static C_{0a}	Nominal	Max.		L_1	L_2	L_3	L_4					
PSS1520N1D0261	15	20	5 070	8 730	100	129	51	186	204	261	18					
PSS1520N1D0361					200	229		286	304	361						
PSS1520N1D0461					300	329		386	404	461						
PSS1520N1D0561					400	429		486	504	561						
PSS1520N1D0661					500	529		586	604	661						
PSS1520N1D0761					600	629		686	704	761						
PSS1520N1D0879					700	729		786	804	879						
PSS1520N1D0979					800	829		886	904	979						
PSS1520N1D1179					1 000	1 029		1 086	1 104	1 179						
PSS1530N1D0311					30	5 070		8 730	100	153		71	230	254	311	24
PSS1530N1D0411									200	253			330	354	411	
PSS1530N1D0511									300	353			430	454	511	
PSS1530N1D0611									400	453			530	554	611	
PSS1530N1D0711									500	553			630	654	711	
PSS1530N1D0811									600	653			730	754	811	
PSS1530N1D0929	700	753	830	854			929									
PSS1530N1D1029	800	853	930	954			1 029									
PSS1530N1D1229	1 000	1 053	1 130	1 154			1 229									

- Notes: 1. Indicates ball screw preload control value. Approximately 2.0 N-cm of torque is added due to thin plastic seals.
 2. Contact NSK if permissible rotational speed is to be exceeded.
 3. Service temperature range is 0 to 80°C.

Left shaft end (opposite driven side)	Lead accuracy			Shaft run-out C	Dynamic preload torque (N-cm) *1	Mass (kg)	Permissible rotational speed (min ⁻¹) *2		Internal spatial volume of nut (cm ³)	Standard volume of grease replenishing (cm ³)
	Target value T	Error e_p	Variation v_u				Fixed-Simple	Fixed-Fixed		
II	0	0.020	0.018	0.035	0.8 - 8.8	0.7	5 000	—	2.8	1.4
II		0.023	0.018	0.045	0.8 - 8.8	0.8	5 000	—		
II		0.025	0.020	0.050	0.8 - 10.8	0.9	5 000	—		
II		0.027	0.020	0.060	0.8 - 10.8	1.1	5 000	—		
II		0.030	0.023	0.075	0.8 - 10.8	1.2	5 000	—		
II		0.035	0.025	0.075	0.8 - 13.8	1.3	4 170	—		
I		0.035	0.025	0.095	0.8 - 13.8	1.5	3 150	4 310		
I		0.040	0.027	0.095	0.8 - 13.8	1.6	2 460	3 390		
I		0.046	0.030	0.120	0.8 - 13.8	1.9	1 620	2 260		
II		0.023	0.018	0.035	1.2 - 9.3	0.8	5 000	—		
II		0.025	0.020	0.050	0.8 - 10.8	1.0	5 000	—		
II		0.027	0.020	0.060	0.8 - 10.8	1.1	5 000	—		
II		0.030	0.023	0.060	0.8 - 10.8	1.2	5 000	—		
II		0.030	0.023	0.075	0.8 - 13.8	1.4	5 000	—		
II		0.035	0.025	0.095	0.8 - 13.8	1.5	3 770	—		
I	0.040	0.027	0.095	0.8 - 13.8	1.6	2 880	3 910			
I	0.040	0.027	0.120	0.8 - 13.8	1.8	2 310	3 110			
I	0.046	0.030	0.120	0.8 - 13.8	2.0	1 540	2 100			

4. Use of NSK support unit is recommended. Refer to page B389 for details.
 5. Recommended quantity of grease is about 50% of ball nut's internal space. See page D16 for details.

Compact FA PSS Type

(Fine, Medium lead)

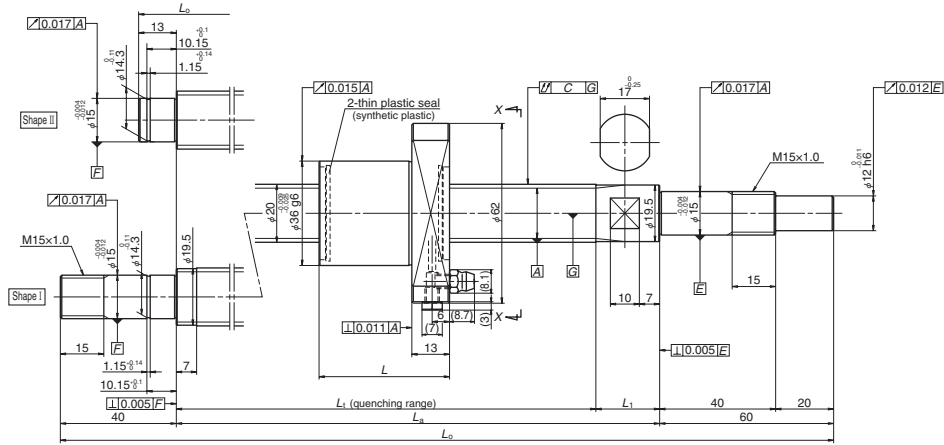

Nut model: BSS

NSK

Screw shaft $\phi 20$

Lead 5, 10

Unit: mm

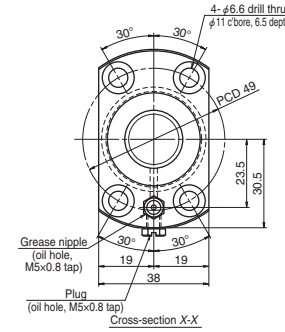

Ball screw specification

Preload type	Oversize ball preload (P-preload)
Ball diameter/screw shaft root diameter	3.175 / 17.2
Ball circle dia.	20.5
Accuracy grade/axial play	C5 / 0
Factory-packed grease	NSK grease LR3

Recommended support unit

For drive side (Fixed)	For opposite to drive side	
	(Fixed)	(Simple)
WBK15-01B (low-profile, square)	WBK15-01B (low-profile, square)	WBK15S-01B (low-profile, square)
WBK15-11 (round)	WBK15-11 (round)	

Unit: mm

Ball screw No.	Screw shaft diameter <i>d</i>	Lead <i>l</i>	Basic load ratings (N)		Stroke		Nut length <i>L</i>	Screw shaft dimensions								
			Dynamic <i>C_a</i>	Static <i>C_{0a}</i>	Nominal	Max.		<i>L_t</i>	<i>L_a</i>	<i>L_b</i>	<i>L₁</i>					
PSS2005N1D0323	20	5	8 790	18 500	150	191	31	228	250	323	22					
PSS2005N1D0373					200	241		278	300	373						
PSS2005N1D0473					300	341		378	400	473						
PSS2005N1D0573					400	441		478	500	573						
PSS2005N1D0673					500	541		578	600	673						
PSS2005N1D0773					600	641		678	700	773						
PSS2005N1D0873					700	741		778	800	873						
PSS2005N1D1000					800	839		878	900	1 000						
PSS2010N1D0387					10	8 790		18 500	200	241		45	292	314	387	22
PSS2010N1D0487									300	341			392	414	487	
PSS2010N1D0587	400	441	492	514			587									
PSS2010N1D0687	500	541	592	614			687									
PSS2010N1D0787	600	641	692	714			787									
PSS2010N1D0887	700	741	792	814			887									
PSS2010N1D1014	800	839	892	914			1 014									
PSS2010N1D1214	1 000	1 039	1 092	1 114			1 214									
PSS2010N1D1414	1 200	1 239	1 292	1 314			1 414									

- Notes: 1. Indicates ball screw preload control value. Approximately 2.0 N-cm of torque is added due to thin plastic seals.
 2. Contact NSK if permissible rotational speed is to be exceeded.
 3. Service temperature range is 0 to 80°C.

Left shaft end (opposite driven side)	Lead accuracy			Shaft run-out <i>C</i>	Dynamic preload torque (N-cm) ^{*1}	Mass (kg)	Permissible rotational speed (min ⁻¹) ^{*2}		Internal spatial volume of nut (cm ³)	Standard volume of grease replenishing (cm ³)		
	Target value <i>T</i>	Error <i>e_p</i>	Variation <i>v_v</i>				Fixed-Simple	Fixed-Fixed				
II	0	0.023	0.018	0.045	0.6 - 7.4	1.0	5 000	—	3.4	1.7		
II		0.023	0.018	0.045	0.6 - 7.4	1.1	5 000	—				
II		0.025	0.020	0.050	0.6 - 7.4	1.3	5 000	—				
II		0.027	0.020	0.060	0.4 - 9.8	1.5	5 000	—				
II		0.030	0.023	0.075	0.4 - 9.8	1.7	5 000	—				
II		0.035	0.025	0.075	0.4 - 9.8	1.9	5 000	—				
II		0.035	0.025	0.095	0.4 - 9.8	2.2	4 410	—				
I		0.040	0.027	0.095	0.4 - 11.8	2.4	3 450	4 710				
II		0.023	0.018	0.045	1.2 - 9.3	1.2	5 000	—			3.2	1.6
II		0.025	0.020	0.050	1.2 - 9.3	1.4	5 000	—				
II	0.027	0.020	0.060	0.8 - 10.8	1.7	5 000	—					
II	0.030	0.023	0.075	0.8 - 10.8	1.9	5 000	—					
II	0.035	0.025	0.075	0.8 - 10.8	2.1	5 000	—					
II	0.035	0.025	0.095	0.8 - 10.8	2.4	4 330	—					
I	0.040	0.027	0.120	0.8 - 13.8	2.6	3 400	4 640					
I	0.046	0.030	0.120	0.8 - 13.8	3.1	2 250	3 110					
I	0.054	0.035	0.160	0.8 - 13.8	3.6	1 600	2 220					

4. Use of NSK support unit is recommended. Refer to page B389 for details.
 5. Recommended quantity of grease is about 50% of ball nut's internal space. See page D16 for details.

Compact FA PSS Type

(High helix lead)

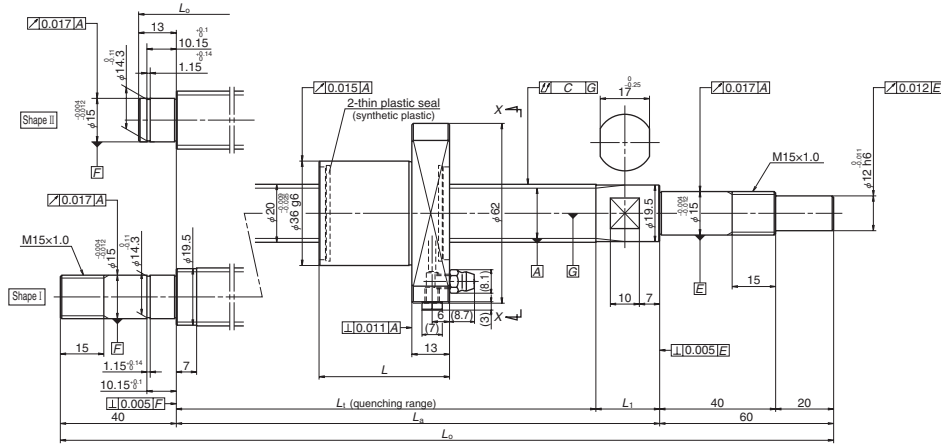

Nut model: BSS

NSK

Screw shaft ø20

Lead 20, 30

Unit: mm

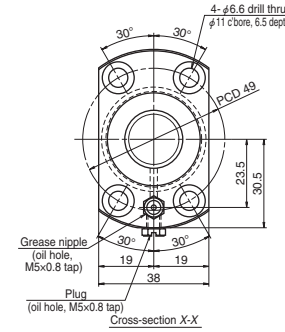

Ball screw specification

Preload type	Oversize ball preload (P-preload)
Ball diameter/screw shaft root diameter	3.175 / 17.2
Ball circle dia.	20.5
Accuracy grade/axial play	C5 / 0
Factory-packed grease	NSK grease LR3

Recommended support unit

For drive side (Fixed)	For opposite to drive side	
	(Fixed)	(Simple)
WBK15-01B (low-profile, square)	WBK15-01B (low-profile, square)	WBK15S-01B (low-profile, square)
WBK15-11 (round)	WBK15-11 (round)	

Unit: mm

Ball screw No.	Screw shaft diameter <i>d</i>	Lead <i>l</i>	Basic load ratings (N)		Stroke		Nut length <i>L</i>	Screw shaft dimensions									
			Dynamic <i>C_a</i>	Static <i>C_{0a}</i>	Nominal	Max.		<i>L_t</i>	<i>L_a</i>	<i>L_b</i>	<i>L₁</i>						
PSS2020N1D0508	20	20	5 900	11 700	300	353	54	413	435	508	22						
PSS2020N1D0608					400	453		513	535	608							
PSS2020N1D0708					500	553		613	635	708							
PSS2020N1D0808					600	653		713	735	808							
PSS2020N1D0908					700	753		813	835	908							
PSS2020N1D1035					800	851		913	935	1 035							
PSS2020N1D1235					1 000	1 051		1 113	1 135	1 235							
PSS2020N1D1435					1 200	1 251		1 313	1 335	1 435							
PSS2020N1D1835					1 600	1 651		1 713	1 735	1 835							
PSS2030N1D0408					30	30		5 900	11 700	200		228	74	308	335	408	27
PSS2030N1D0508										300		328		408	435	508	
PSS2030N1D0608										400		428		508	535	608	
PSS2030N1D0708										500		528		608	635	708	
PSS2030N1D0808										600		628		708	735	808	
PSS2030N1D0908	700	728	808	835			908										
PSS2030N1D1035	800	826	908	935			1 035										
PSS2030N1D1235	1 000	1 026	1 108	1 135			1 235										
PSS2030N1D1435	1 200	1 226	1 308	1 335			1 435										

- Notes: 1. Indicates ball screw preload control value. Approximately 2.0 N-cm of torque is added due to thin plastic seals.
2. Contact NSK if permissible rotational speed is to be exceeded.
3. Service temperature range is 0 to 80°C.

Left shaft end (opposite driven side)	Lead accuracy			Shaft run-out <i>C</i>	Dynamic preload torque (N-cm) *1	Mass (kg)	Permissible rotational speed (min ⁻¹) *2		Internal spatial volume of nut (cm ³)	Standard volume of grease replenishing (cm ³)		
	Target value <i>T</i>	Error <i>e_p</i>	Variation <i>v_u</i>				Fixed-Simple	Fixed-Fixed				
II	0	0.027	0.020	0.060	1.4 - 11.8	1.6	5 000	—	3.2	1.6		
II		0.030	0.023	0.060	1.4 - 11.8	1.8	5 000	—				
II		0.030	0.023	0.075	1.4 - 11.8	2.0	5 000	—				
II		0.035	0.025	0.095	1.4 - 11.8	2.3	5 000	—				
II		0.040	0.027	0.095	0.8 - 13.8	2.5	4 150	—				
I		0.040	0.027	0.120	0.8 - 13.8	2.8	3 270	4 470				
I		0.046	0.030	0.120	0.8 - 13.8	3.3	2 180	3 010				
I		0.054	0.035	0.160	0.8 - 13.8	3.8	1 550	2 170				
I		0.065	0.040	0.200	0.8 - 13.8	4.7	900	1 270				
II		0.023	0.018	0.050	1.6 - 9.8	1.4	5 000	—			4.6	2.3
II		0.027	0.020	0.060	1.4 - 11.8	1.7	5 000	—				
II		0.030	0.023	0.060	1.4 - 11.8	1.9	5 000	—				
II		0.030	0.023	0.075	1.4 - 11.8	2.1	5 000	—				
II		0.035	0.025	0.095	1.4 - 11.8	2.4	5 000	—				
II	0.040	0.027	0.095	0.8 - 13.8	2.6	4 310	—					
I	0.040	0.027	0.120	0.8 - 13.8	2.9	3 380	4 570					
I	0.046	0.030	0.120	0.8 - 13.8	3.4	2 240	3 070					
I	0.054	0.035	0.160	0.8 - 13.8	3.9	1 590	2 200					

4. Use of NSK support unit is recommended. Refer to page B389 for details.
5. Recommended quantity of grease is about 50% of ball nut's internal space. See page D16 for details.

Compact FA PSS Type

(Ultra high helix lead)

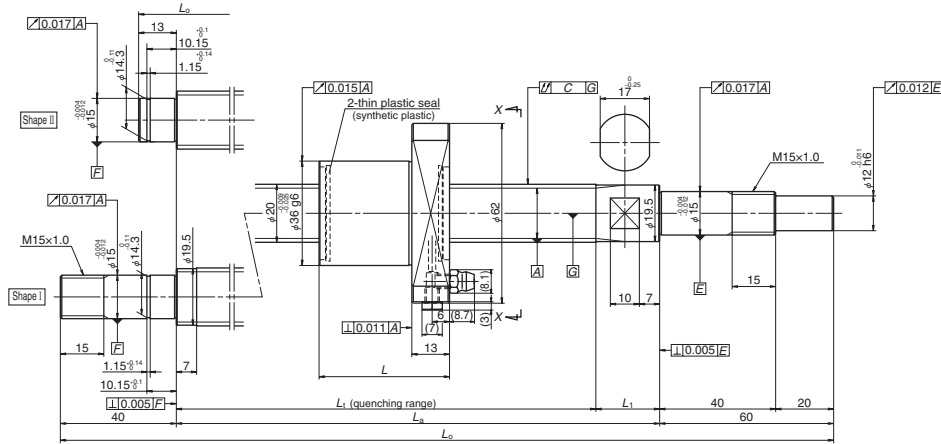

Nut model: BSS



Screw shaft ø20

Lead 40, 60

Unit: mm

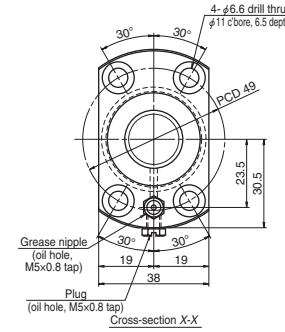

Ball screw specification

Preload type	Oversize ball preload (P-preload)
Ball diameter/screw shaft root diameter	3.175 / 17.2
Ball circle dia.	20.5
Accuracy grade/axial play	C5 / 0
Factory-packed grease	NSK grease LR3

Recommended support unit

For drive side (Fixed)	For opposite to drive side	
	(Fixed)	(Simple)
WBK15-01B (low-profile, square)	WBK15-01B (low-profile, square)	WBK15S-01B (low-profile, square)
WBK15-11 (round)	WBK15-11 (round)	

Unit: mm

Ball screw No.	Screw shaft diameter <i>d</i>	Lead <i>l</i>	Basic load ratings (N)		Stroke		Nut length <i>L</i>	Screw shaft dimensions								
			Dynamic <i>C_a</i>	Static <i>C_{0a}</i>	Nominal	Max.		<i>L_t</i>	<i>L_a</i>	<i>L_b</i>	<i>L₁</i>					
												<i>C_a</i>	<i>C_{0a}</i>	Nominal	Max.	
PSS2040N1D0658	20	40	5 900	11 700	400	455	92	553	585	658	32					
PSS2040N1D0758					500	555		653	685	758						
PSS2040N1D0858					600	655		753	785	858						
PSS2040N1D0958					700	755		853	885	958						
PSS2040N1D1085					800	853		953	985	1 085						
PSS2040N1D1285					1 000	1 053		1 153	1 185	1 285						
PSS2040N1D1485					1 200	1 253		1 353	1 385	1 485						
PSS2040N1D1885					1 600	1 653		1 753	1 785	1 885						
PSS2040N1D2285					2 000	2 053		2 153	2 185	2 285						
PSS2060N1D0708					60	5 900		11 700	400	458		129	593	635	708	42
PSS2060N1D0808									500	558			693	735	808	
PSS2060N1D0908									600	658			793	835	908	
PSS2060N1D1008									700	758			893	935	1 008	
PSS2060N1D1135									800	856			993	1 035	1 135	
PSS2060N1D1335	1 000	1 056	1 193	1 235			1 335									
PSS2060N1D1535	1 200	1 256	1 393	1 435			1 535									
PSS2060N1D1935	1 600	1 656	1 793	1 835			1 935									
PSS2060N1D2335	2 000	2 056	2 193	2 235			2 335									

- Notes: 1. Indicates ball screw preload control value. Approximately 2.0 N-cm of torque is added due to thin plastic seals.
 2. Contact NSK if permissible rotational speed is to be exceeded.
 3. Service temperature range is 0 to 80°C.

Left shaft end (opposite driven side)	Lead accuracy			Shaft run-out <i>C</i>	Dynamic preload torque (N-cm) ^{*1}	Mass (kg)	Permissible rotational speed (min ⁻¹) ^{*2}		Internal spatial volume of nut (cm ³)	Standard volume of grease replenishing (cm ³)
	Target value <i>T</i>	Error <i>e_p</i>	Variation <i>v_v</i>				Fixed-Simple	Fixed-Fixed		
II	0	0.030	0.023	0.075	2.2 - 12.8	2.1	5 000	—	5.3	2.7
II		0.035	0.025	0.075	2.2 - 12.8	2.4	5 000	—		
II		0.035	0.025	0.095	2.2 - 12.8	2.6	5 000	—		
II		0.040	0.027	0.095	1.8 - 14.8	2.8	3 940	—		
I		0.040	0.027	0.120	1.8 - 14.8	3.1	3 120	4 190		
I		0.046	0.030	0.160	1.8 - 14.8	3.6	2 100	2 850		
I		0.054	0.035	0.160	1.8 - 14.8	4.1	1 500	2 070		
I		0.065	0.040	0.200	1.8 - 14.8	5.1	880	1 230		
I		0.077	0.046	0.240	1.8 - 14.8	6.0	580	810		
II		0.030	0.023	0.075	2.7 - 13.8	2.4	5 000	—		
II		0.035	0.025	0.095	2.7 - 13.8	2.6	5 000	—		
II		0.035	0.025	0.095	2.7 - 13.8	2.9	4 830	—		
II		0.040	0.027	0.120	1.8 - 14.8	3.1	3 740	—		
I		0.040	0.027	0.120	1.8 - 14.8	3.4	2 980	3 920		
I	0.046	0.030	0.160	1.8 - 14.8	3.9	2 020	2 700			
I	0.054	0.035	0.160	1.8 - 14.8	4.4	1 460	1 970			
I	0.065	0.040	0.200	1.8 - 14.8	5.4	860	1 180			
I	0.077	0.046	0.240	1.8 - 14.8	6.3	570	790			

4. Use of NSK support unit is recommended. Refer to page B389 for details.
 5. Recommended quantity of grease is about 50% of ball nut's internal space. See page D16 for details.

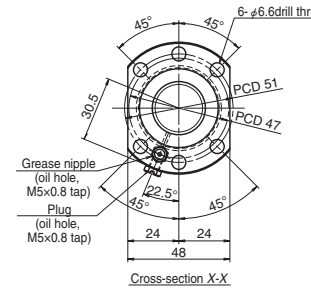
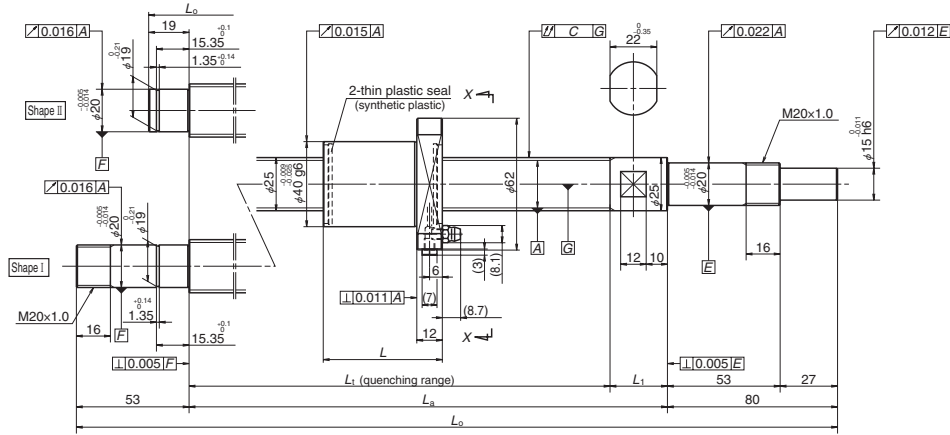

Ball screw specification

Preload type	Oversize ball preload (P-preload)
Ball diameter/screw shaft root diameter	3.175 / 22.2
Ball circle dia.	25.5
Accuracy grade/axial play	C5 / 0
Factory-packed grease	NSK grease LR3

Recommended support unit

For drive side (Fixed)	For opposite to drive side	
	(Fixed)	(Simple)
WBK20-01 (square)	WBK20-01 (square)	WBK20S-01 (square)
WBK20-11 (round)	WBK20-11 (round)	

Ball screw No.	Screw shaft diameter <i>d</i>	Lead <i>l</i>	Basic load ratings (N)		Stroke		Nut length <i>L</i>	Screw shaft dimensions			
			Dynamic <i>C_a</i>	Static <i>C_{0a}</i>	Nominal	Max.		<i>L₁</i>	<i>L_a</i>	<i>L_b</i>	<i>L_c</i>
PSS2505N1D0349	25	5	9 760	23 600	150	185	32	223	250	349	27
PSS2505N1D0399					200	235		273	300	399	
PSS2505N1D0499					300	335		373	400	499	
PSS2505N1D0599					400	435		473	500	599	
PSS2505N1D0699					500	535		573	600	699	
PSS2505N1D0899					700	735		773	800	899	
PSS2505N1D0999					800	835		873	900	999	
PSS2505N1D1233		1 000	1 027	1 073	1 100	1 233					
PSS2510N1D0549		10	12 800	32 300	300	361	56	423	450	549	27
PSS2510N1D0649					400	461		523	550	649	
PSS2510N1D0749					500	561		623	650	749	
PSS2510N1D0849					600	661		723	750	849	
PSS2510N1D0949					700	761		823	850	949	
PSS2510N1D1049					800	861		923	950	1 049	
PSS2510N1D1283	1 000				1 053	1 123		1 150	1 283		
PSS2510N1D1883	1 600	1 653	1 723	1 750	1 883						

- Notes: 1. Indicates ball screw preload control value. Approximately 2.0 N-cm of torque is added due to thin plastic seals.
 2. Contact NSK if permissible rotational speed is to be exceeded.
 3. Service temperature range is 0 to 80°C.

Left shaft end (opposite driven side)	Lead accuracy			Shaft run-out <i>C</i>	Dynamic preload torque (N-cm) *1	Mass (kg)	Permissible rotational speed (min ⁻¹) *2		Internal spatial volume of nut (cm ³)	Standard volume of grease replenishing (cm ³)
	Target value <i>T</i>	Error <i>e_p</i>	Variation <i>v_v</i>				Fixed-Simple	Fixed-Fixed		
II	0	0.023	0.018	0.035	1.2 - 9.3	1.5	5 000	—	4.4	2.2
II		0.023	0.018	0.035	1.2 - 9.3	1.6	5 000	—		
II		0.025	0.020	0.040	1.2 - 9.3	2.0	5 000	—		
II		0.027	0.020	0.045	1.2 - 9.3	2.3	5 000	—		
II		0.030	0.023	0.055	0.8 - 10.8	2.7	5 000	—		
II		0.035	0.025	0.065	0.8 - 10.8	3.4	5 000	—		
II		0.040	0.027	0.065	0.8 - 10.8	3.7	4 490	—		
I		0.046	0.030	0.080	0.8 - 13.8	4.5	2 960	4 060		
II		0.027	0.020	0.045	3.1 - 11.8	2.4	5 000	—	4.7	2.4
II		0.030	0.023	0.055	2.2 - 12.8	2.7	5 000	—		
II		0.030	0.023	0.055	2.2 - 12.8	3.1	5 000	—		
II		0.035	0.025	0.065	2.2 - 12.8	3.5	5 000	—		
II		0.040	0.027	0.065	2.2 - 12.8	3.8	5 000	—		
I		0.046	0.030	0.100	1.8 - 14.8	5.0	2 760	3 790		
I	0.065	0.040	0.130	1.8 - 14.8	7.2	1 150	1 620			

4. Use of NSK support unit is recommended. Refer to page B389 for details.
 5. Recommended quantity of grease is about 50% of ball nut's internal space. See page D16 for details.

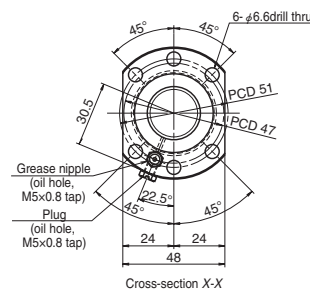
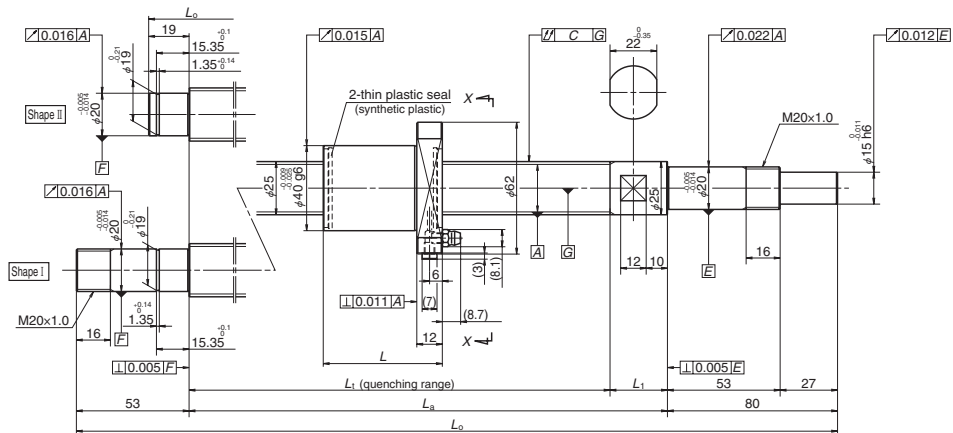

Ball screw specification	
Preload type	Oversize ball preload (P-preload)
Ball diameter/screw shaft root diameter	3.175 / 22.2
Ball circle dia.	25.5
Accuracy grade/axial play	C5 / 0
Factory-packed grease	NSK grease LR3

Recommended support unit		
For drive side (Fixed)	For opposite to drive side (Fixed) (Simple)	
WBK20-01 (square)	WBK20-01 (square)	WBK20S-01 (square)
WBK20-11 (round)	WBK20-11 (round)	

Ball screw No.	Screw shaft diameter <i>d</i>	Lead <i>l</i>	Basic load ratings (N)		Stroke		Nut length <i>L</i>	Screw shaft dimensions									
			Dynamic <i>C_a</i>	Static <i>C_{0a}</i>	Nominal	Max.		<i>L₁</i>	<i>L_a</i>	<i>L_b</i>	<i>L_c</i>						
												<i>L₁</i>					
PSS2520N1D0729	25	20	6 560	14 600	500	544	54	604	630	729	26						
PSS2520N1D0829					600	644		704	730	829							
PSS2520N1D0929					700	744		804	830	929							
PSS2520N1D1029					800	844		904	930	1 029							
PSS2520N1D1263					1 000	1 036		1 104	1 130	1 263							
PSS2520N1D1463					1 200	1 236		1 304	1 330	1 463							
PSS2520N1D1863					1 600	1 636		1 704	1 730	1 863							
PSS2520N1D2263					2 000	2 036		2 104	2 130	2 263							
PSS2525N1D0779					25	25		6 560	14 600	500		581	63	650	680	779	30
PSS2525N1D0879										600		681		750	780	879	
PSS2525N1D0979										700		781		850	880	979	
PSS2525N1D1079										800		881		950	980	1 079	
PSS2525N1D1313										1 000		1 073		1 150	1 180	1 313	
PSS2525N1D1513										1 200		1 273		1 350	1 380	1 513	
PSS2525N1D1913	1 600	1 673	1 750	1 780			1 913										
PSS2525N1D2313	2 000	2 073	2 150	2 180			2 313										

Notes: 1. Indicates ball screw preload control value. Approximately 2.0 N-cm of torque is added due to thin plastic seals.
 2. Contact NSK if permissible rotational speed is to be exceeded.
 3. Service temperature range is 0 to 80°C.

Left shaft end (opposite driven side)	Lead accuracy			Shaft run-out <i>C</i>	Dynamic preload torque (N-cm)*1	Mass (kg)	Permissible rotational speed (min) ^{*)2}		Internal spatial volume of nut (cm ³)	Standard volume of grease replenishing (cm ³)
	Target value <i>T</i>	Error <i>e_p</i>	Variation <i>v_i</i>				Fixed-Simple	Fixed-Fixed		
II	0	0.030	0.023	0.055	2.2 - 12.8	3.1	5 000	—	3.9	2.0
II		0.035	0.025	0.065	2.2 - 12.8	3.4	5 000	—		
II		0.040	0.027	0.065	2.2 - 12.8	3.8	5 000	—		
II		0.040	0.027	0.080	2.2 - 12.8	4.2	4 280	—		
I		0.046	0.030	0.100	1.8 - 14.8	5.0	2 850	3 920		
I		0.054	0.035	0.100	1.8 - 14.8	5.8	2 030	2 820		
I		0.065	0.040	0.130	1.8 - 14.8	7.3	1 180	1 650		
I		0.077	0.046	0.170	1.8 - 14.8	8.8	770	1 080		
II		0.035	0.025	0.055	2.7 - 13.8	3.3	5 000	—	4.3	2.2
II		0.035	0.025	0.065	2.7 - 13.8	3.7	5 000	—		
II		0.040	0.027	0.065	2.7 - 13.8	4.1	4 910	—		
II		0.040	0.027	0.080	2.7 - 13.8	4.4	3 910	—		
I		0.046	0.030	0.100	1.8 - 14.8	5.3	2 640	3 620		
I		0.054	0.035	0.100	1.8 - 14.8	6.0	1 900	2 630		
I		0.065	0.040	0.130	1.8 - 14.8	7.5	1 120	1 570		
I		0.077	0.046	0.170	1.8 - 14.8	9.1	740	1 040		

4. Use of NSK support unit is recommended. Refer to page B389 for details.
 5. Recommended quantity of grease is about 50% of ball nut's internal space. See page D16 for details.

Compact FA PSS Type

(High helix, Ultra high helix lead)

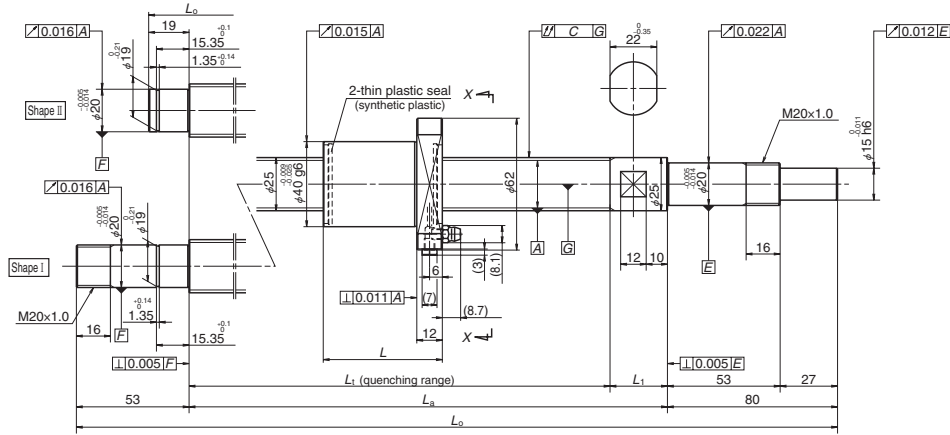

Nut model: BSS

NSK

Screw shaft $\phi 25$

Lead 30, 50

Unit: mm

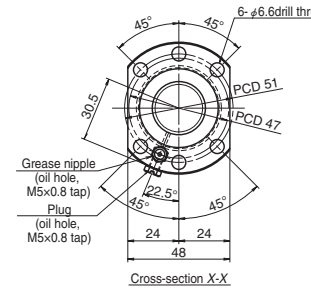

Ball screw specification

Preload type	Oversize ball preload (P-preload)
Ball diameter/screw shaft root diameter	3.175 / 22.2
Ball circle dia.	25.5
Accuracy grade/axial play	C5 / 0
Factory-packed grease	NSK grease LR3

Recommended support unit

For drive side (Fixed)	For opposite to drive side	
	(Fixed)	(Simple)
WBK20-01 (square)	WBK20-01 (square)	WBK20S-01 (square)
WBK20-11 (round)	WBK20-11 (round)	

Ball screw No.	Screw shaft diameter d	Lead l	Basic load ratings (N)		Stroke		Nut length L	Screw shaft dimensions			
			Dynamic C_a	Static C_{0a}	Nominal	Max.		L_1	L_a	L_b	L_1
PSS2530N1D0779	25	30	6 560	14 600	500	570	74	650	680	779	30
PSS2530N1D0879					600	670		750	780	879	
PSS2530N1D0979					700	770		850	880	979	
PSS2530N1D1079					800	870		950	980	1 079	
PSS2530N1D1313					1 000	1 062		1 150	1 180	1 313	
PSS2530N1D1513					1 200	1 262		1 350	1 380	1 513	
PSS2530N1D1913					1 600	1 662		1 750	1 780	1 913	
PSS2530N1D2313		2 000	2 062	2 150	2 180	2 313					
PSS2550N1D0829		50	6 560	14 600	500	570	114	690	730	829	40
PSS2550N1D0929					600	670		790	830	929	
PSS2550N1D1029					700	770		890	930	1 029	
PSS2550N1D1129					800	870		990	1 030	1 129	
PSS2550N1D1363					1 000	1 062		1 190	1 230	1 363	
PSS2550N1D1563					1 200	1 262		1 390	1 430	1 563	
PSS2550N1D1963	1 600				1 662	1 790		1 830	1 963		
PSS2550N1D2363	2 000	2 062	2 190	2 230	2 363						

- Notes: 1. Indicates ball screw preload control value. Approximately 2.0 N-cm of torque is added due to thin plastic seals.
2. Contact NSK if permissible rotational speed is to be exceeded.
3. Service temperature range is 0 to 80°C.

Unit: mm

Left shaft end (opposite driven side)	Lead accuracy			Shaft run-out C	Dynamic preload torque (N-cm) ^{*1}	Mass (kg)	Permissible rotational speed (min ⁻¹) ^{*2}		Internal spatial volume of nut (cm ³)	Standard volume of grease replenishing (cm ³)
	Target value T	Error e_p	Variation v_u				Fixed-Simple	Fixed-Fixed		
II	0	0.035	0.025	0.055	2.7 - 13.8	3.4	5 000	—	5.5	2.8
II		0.035	0.025	0.065	2.7 - 13.8	3.7	5 000	—		
II		0.040	0.027	0.065	2.7 - 13.8	4.1	4 980	—		
II		0.040	0.027	0.080	2.7 - 13.8	4.5	3 960	—		
I		0.046	0.030	0.100	1.8 - 14.8	5.3	2 670	3 650		
I		0.054	0.035	0.100	1.8 - 14.8	6.1	1 920	2 650		
I		0.065	0.040	0.130	1.8 - 14.8	7.6	1 130	1 580		
I		0.077	0.046	0.170	1.8 - 14.8	9.1	740	1 040		
II		0.035	0.025	0.065	5.4 - 17.6	3.8	5 000	—	7.7	3.9
II		0.035	0.025	0.065	5.4 - 17.6	4.1	5 000	—		
II		0.040	0.027	0.080	5.4 - 17.6	4.5	4 750	—		
II		0.040	0.027	0.080	5.4 - 17.6	4.9	3 790	—		
I		0.046	0.030	0.100	4.1 - 19.6	5.8	2 570	3 470		
I		0.054	0.035	0.100	4.1 - 19.6	6.5	1 860	2 540		
I	0.065	0.040	0.130	4.1 - 19.6	8.0	1 100	1 520			
I	0.077	0.046	0.170	4.1 - 19.6	9.6	730	1 020			

4. Use of NSK support unit is recommended. Refer to page B389 for details.
5. Recommended quantity of grease is about 50% of ball nut's internal space. See page D16 for details.

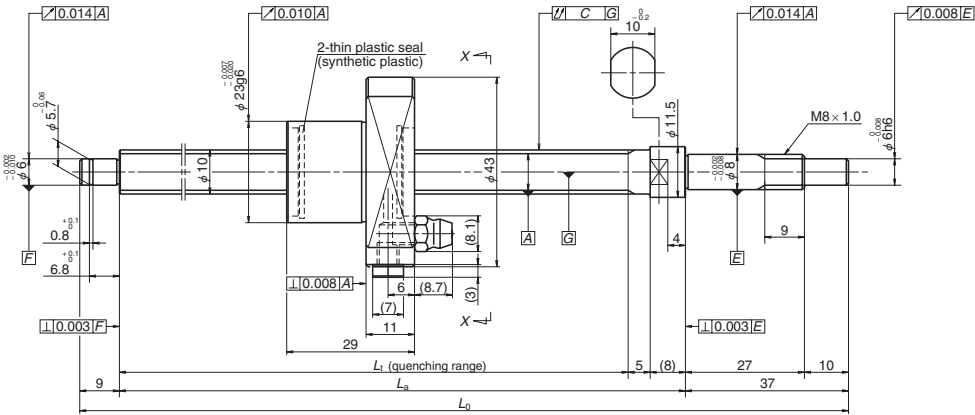

Ball screw No.	Screw shaft diameter <i>d</i>	Lead <i>l</i>	Basic load ratings (N)		Stroke		Screw shaft dimensions		
			Dynamic <i>C_d</i>	Static <i>C_{0a}</i>	Nominal	Max.	<i>L_t</i>	<i>L_a</i>	<i>L_o</i>
USS1005N1D0221	10	5	2 930	4 790	100	133	162	175	221
USS1005N1D0321					200	233	262	275	321
USS1005N1D0521					400	433	462	475	521

Notes: 1. Indicates ball screw preload control value. Approximately 0.5 N-cm of torque is added due to thin plastic seals.
 2. Contact NSK if permissible rotational speed is to be exceeded.
 3. Service temperature range is 0 to 80°C.

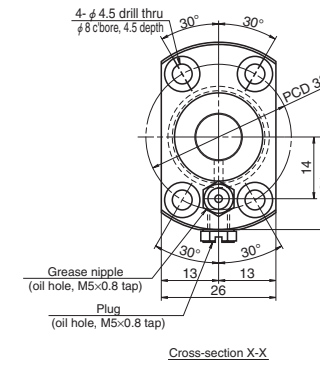

Ball screw specification	
Preload type	Oversize ball preload (P-preload)
Ball diameter/screw shaft root diameter	2.000 / 8.2
Ball circle dia.	10.3
Accuracy grade/axial play	C3 / 0
Factory-packed grease	NSK grease LG2

Recommended support unit	
For drive side (Fixed)	For opposite to drive side (Simple)
WBK08-01C (square, clean)	WBK08S-01C (square, clean)
WBK08-11C (round, clean)	WBK08S-01B (low-profile, square)
WBK08-01B (low-profile, square)	
WBK08-11 (round)	

Target value <i>T</i>	Lead accuracy		Shaft run-out <i>C</i>	Dynamic preload torque (N-cm) *1	Mass (kg)	Permissible rotational speed (min ⁻¹) *2	Internal spatial volume of nut (cm ³)	Standard volume of grease replenishing (cm ³)
	Error <i>e_p</i>	Variation <i>V_v</i>						
0	0.010	0.008	0.035	0.2-1.8	0.3	5 000	0.8	0.4
	0.012	0.008	0.045	0.2-2.0	0.3			
	0.015	0.010	0.070	0.2-3.0	0.5			

4. Use of NSK support unit is recommended. See page B389 for details.

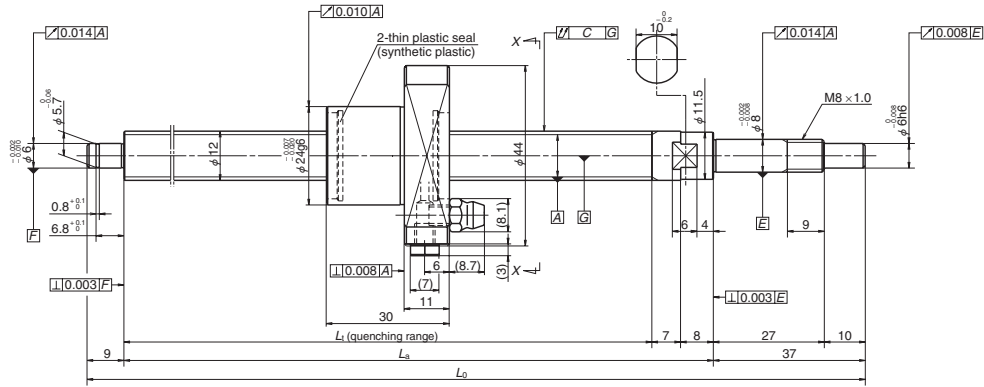

Ball screw No.	Screw shaft diameter <i>d</i>	Lead <i>l</i>	Basic load ratings (N)		Stroke		Screw shaft dimensions		
			Dynamic <i>C_d</i>	Static <i>C_{0a}</i>	Nominal	Max.	<i>L₁</i>	<i>L_a</i>	<i>L_o</i>
USS1205N1D0221	12	5	3 200	5 860	100	130	160	175	221
USS1205N1D0321					200	230	260	275	321
USS1205N1D0621					500	530	560	575	621

Notes: 1. Indicates ball screw preload control value. Approximately 0.5 N-cm of torque is added due to thin plastic seals.
 2. Contact NSK if permissible rotational speed is to be exceeded.
 3. Service temperature range is 0 to 80°C.

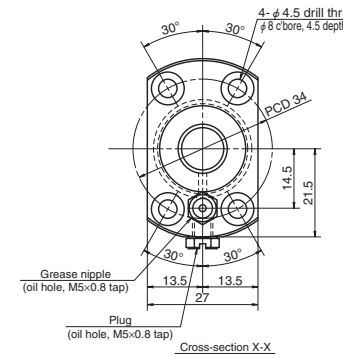

Ball screw specification	
Preload type	Oversize ball preload (P-preload)
Ball diameter/screw shaft root diameter	2.000 / 10.2
Ball circle dia.	12.3
Accuracy grade/axial play	C3 / 0
Factory-packed grease	NSK grease LG2

Recommended support unit	
For drive side (Fixed)	For opposite to drive side (Simple)
WBK08-01C (square, clean)	WBK08S-01C (square, clean)
WBK08-11C (round, clean)	WBK08S-01B (low-profile, square)
WBK08-01B (low-profile, square)	
WBK08-11 (round)	

Target value <i>T</i>	Lead accuracy		Shaft run-out <i>C</i>	Dynamic preload torque (N-cm) *1	Mass (kg)	Permissible rotational speed (min ⁻¹) *2	Internal spatial volume of nut (cm ³)	Standard volume of grease replenishing (cm ³)
	Error <i>e_p</i>	Variation <i>V_v</i>						
0	0.010	0.008	0.035	0.2-1.8	0.3	5 000	1.0	0.5
	0.012	0.008	0.045	0.2-2.0	0.3			
	0.016	0.012	0.070	0.2-3.0	0.7			

4. Use of NSK support unit is recommended. See page B389 for details.

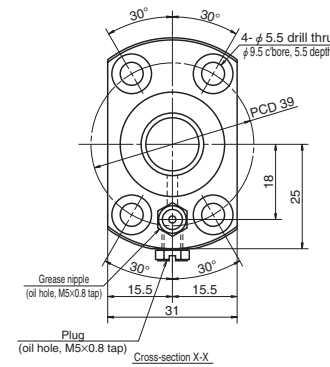
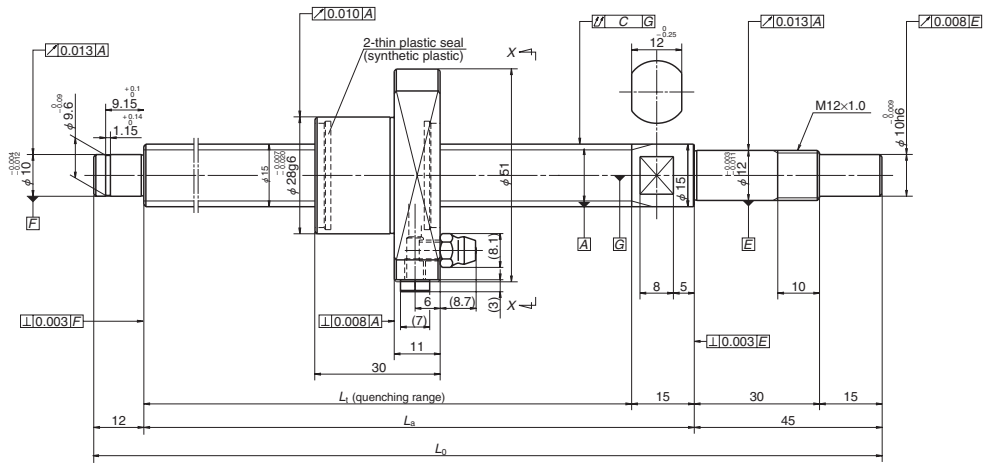

Ball screw specification

Preload type	Oversize ball preload (P-preload)
Ball diameter/screw shaft root diameter	2.778 / 12.6
Ball circle dia.	15.5
Accuracy grade/axial play	C3 / 0
Factory-packed grease	NSK grease LG2

Recommended support unit

For drive side (Fixed)	For opposite to drive side (Simple)
WBK12-01C (square, clean)	WBK12S-01C (square, clean)
WBK12-11C (round, clean)	WBK12-01B (low-profile, square)
WBK12S-01B (low-profile, square)	
WBK12-11 (round)	

Ball screw No.	Screw shaft diameter <i>d</i>	Lead <i>l</i>	Basic load ratings (N)		Stroke		Screw shaft dimensions		
			Dynamic <i>C_d</i>	Static <i>C_{0a}</i>	Nominal	Max.	<i>L_t</i>	<i>L_a</i>	<i>L_o</i>
USS1505N1D0261	15	5	5 460	10 200	100	159	189	204	261
USS1505N1D0361					200	259	289	304	361
USS1505N1D0561					400	459	489	504	561
USS1505N1D0761					600	653	689	704	761

Notes: 1. Indicates ball screw preload control value. Approximately 0.5 N-cm of torque is added due to thin plastic seals.
2. Contact NSK if permissible rotational speed is to be exceeded.
3. Service temperature range is 0 to 80°C.

Target value <i>T</i>	Lead accuracy		Shaft run-out <i>C</i>	Dynamic preload torque (N-cm) *1	Mass (kg)	Permissible rotational speed (min ⁻¹) *2		Internal spatial volume of nut (cm ³)	Standard volume of grease replenishing (cm ³)
	Error <i>e_p</i>	Variation <i>V_o</i>				Fixed	Simple		
0	0.010	0.008	0.025	0.2-5.0	0.5	5 000	2.0	1.0	
	0.012	0.008	0.035	0.2-5.0	0.6	5 000			
	0.015	0.010	0.045	0.2-6.0	0.9	5 000			
	0.018	0.013	0.060	0.2-8.0	1.1	4 130			

4. Use of NSK support unit is recommended. See page B389 for details.

Compact FA FSS Type

(Medium lead)

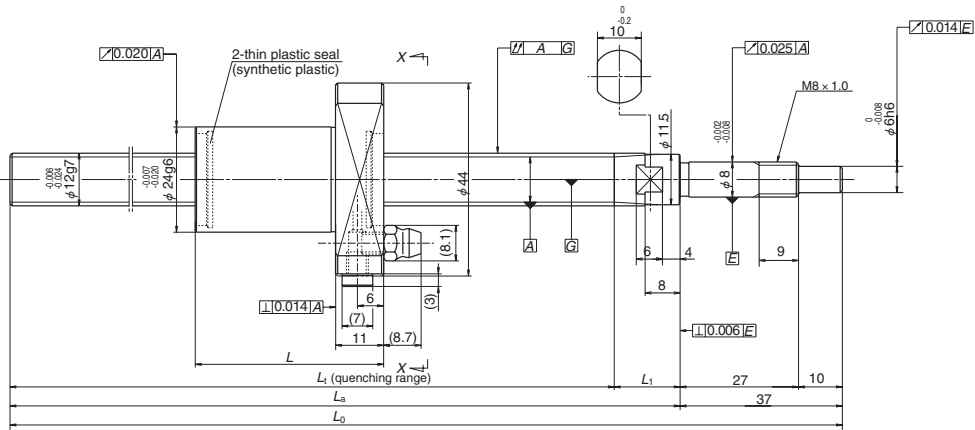

Nut model: BSS

NSK

Screw shaft $\phi 12$

Lead 10

Unit: mm

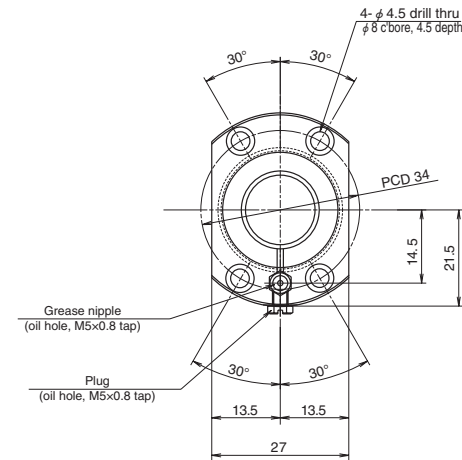

Ball screw specification

Ball diameter/screw shaft root diameter	2.000 / 10.2
Accuracy grade/axial play	Ct7 / 0.010 or less
Factory-packed grease	NSK grease LR3

Recommended support unit

For drive side (Fixed)	For opposite to drive side (Simple)
WBK08-01B (low-profile, square)	WBK12SF-01B (low-profile, square)

Ball screw No.	Screw shaft diameter d	Lead l	Basic load ratings (N)		Stroke		Nut length L	Screw shaft dimensions			
			Dynamic C_d	Static C_{0a}	Nominal	Max.		L_1	L_2	L_3	L_4
FSS1210N1D0400	12	10	3 200	5 860	250	287	43	348	363	400	15
FSS1210N1D0600					450	487		548	563	600	
FSS1210N1D0900					750	787		848	863	900	

- Notes: 1. Indicates ball screw preload control value. Approximately 2.0 N-cm of torque is added due to thin plastic seals.
2. Service temperature range is 0 to 80°C.
3. Use of NSK support unit is recommended. See page B389 for details.

Lead accuracy			Shaft run-out C	Dynamic preload torque (N-cm)	Mass (kg)	Permissible rotational speed (min ⁻¹) ^{*5}	Internal spatial volume of nut (cm ³)	Standard volume of grease replenishing (cm ³)
Target value T	Error e_p	Variation V_{300}						
0	0.120	0.052	0.080	-	0.5	5 000	1.0	0.5
	0.195		0.120		0.7			
	0.310		0.180		1.0			

4. The stroke and permissible rotational speed shown in the table are the values when the support unit recommended by NSK is used and Fixed-Supported (ball screw mounting method) is selected.
5. Permissible rotational speed varies when using cut screw shaft. It is necessary to calculate two items below, and whichever smaller is the permissible rotational speed.
*Critical speed which is the resonance vibration of the shaft (page B47).
*Maximum rotational speed 5 000 min⁻¹

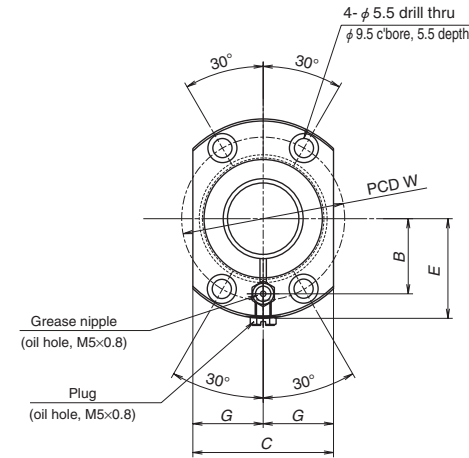
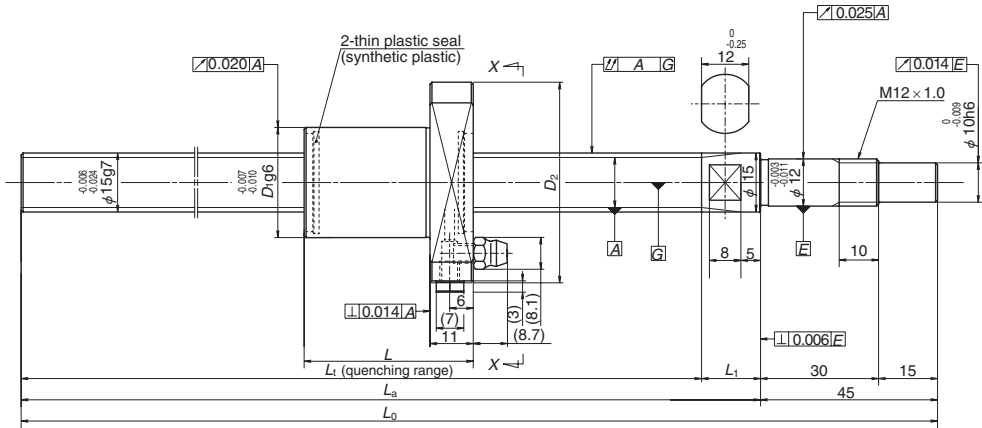

Ball screw specification		
Lead	10	20
Ball diameter/screw shaft root diameter	2.778 / 12.6	3.175 / 12.2
Accuracy grade/axial play	Ct7 / 0.010 or less	
Factory-packed grease	NSK grease LR3	

Recommended support unit	
For drive side (Fixed)	For opposite to drive side (Simple)
WBK12-01B (low-profile, square)	WBK15SF-01B (low-profile, square)

Ball screw No.	Screw shaft diameter <i>d</i>	Lead <i>l</i>	Basic load ratings (N)		Stroke		Screw shaft dimensions				Lead accuracy			
			Dynamic <i>C_d</i>	Static <i>C_{0a}</i>	Nominal	Max.	<i>L₁</i>	<i>L_a</i>	<i>L₀</i>	<i>L₁</i>	Target value <i>T</i>	Error <i>e_p</i>	Variation <i>V₃₀₀</i>	
FSS1510N1D0500	15	10	5 460	10 200	350	379	440	455	500	15	0	0.155	0.052	
FSS1510N1D1000					850	879	940	955	1 000					0.310
FSS1510N1D1450					1 300	1 329	1 390	1 405	1 450					
FSS1520N1D0500		20	5 070	8 730	350	368	437	455	500	18	0	0.155	0.052	
FSS1520N1D1000					850	868	937	955	1 000					0.310
FSS1520N1D1450					1 300	1 318	1 387	1 405	1 450					

Notes: 1. Indicates ball screw preload control value. Approximately 2.0 N-cm of torque is added due to thin plastic seals.
 2. Service temperature range is 0 to 80°C.
 3. Use of NSK support unit is recommended. See page B389 for details.

Nut dimensions								Shaft run-out <i>C</i>	Dynamic preload torque (N-cm)	Mass (kg)	Permissible rotational speed (min ⁻¹) ^{4,5}		Internal spatial volume of nut (cm ³)	Standard volume of grease replenishing (cm ³)
<i>L</i>	<i>D₁</i>	<i>D₂</i>	<i>W</i>	<i>B</i>	<i>C</i>	<i>E</i>	<i>G</i>				Fixed	Simple		
43	28	51	39	18	31	25	15.5	0.070	-	0.9	5 000	2.0	1.0	
								0.125		1.7	2 300			
								0.200		2.3	1 020			
51	32	55	43	20	33	27	16.5	0.070	-	1.0	5 000	2.8	1.4	
								0.125		1.7	2 260			
								0.200		2.3	1 000			

4. The stroke and permissible rotational speed shown in the table are the values when the support unit recommended by NSK is used and Fixed-Supported (ball screw mounting method) is selected.
 5. Permissible rotational speed varies when using cut screw shaft. It is necessary to calculate two items below, and whichever smaller is the permissible rotational speed.
 *Critical speed which is the resonance vibration of the shaft (page B47).
 *Maximum rotational speed 5 000 min⁻¹

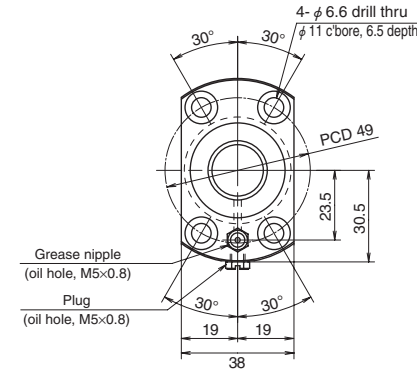
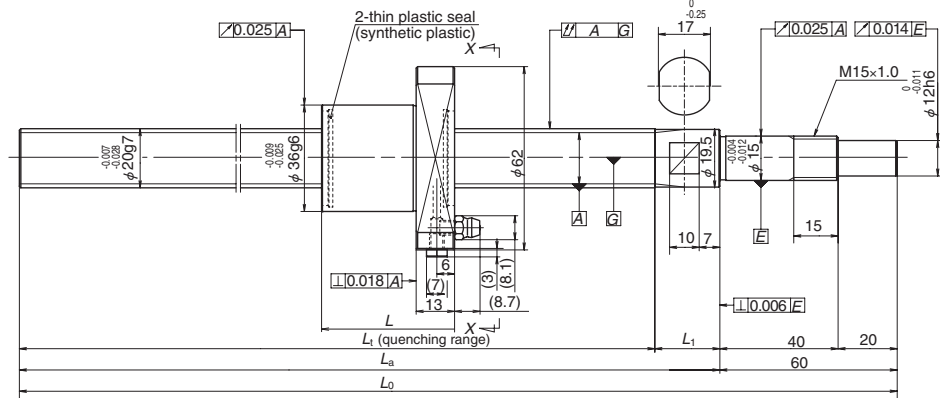

Ball screw specification

Ball diameter/screw shaft root diameter	3.175 / 17.2
Accuracy grade/axial play	Ct7 / 0.010 or less
Factory-packed grease	NSK grease LR3

Recommended support unit

For drive side (Fixed)	For opposite to drive side (Simple)
WBK15-01B (low-profile, square)	WBK20SF-01B (low-profile, square)

Ball screw No.	Screw shaft diameter <i>d</i>	Lead <i>l</i>	Basic load ratings (N)		Stroke		Nut length <i>L</i>	Screw shaft dimensions			
			Dynamic <i>C_d</i>	Static <i>C_{st}</i>	Nominal	Max.		<i>L₁</i>	<i>L_a</i>	<i>L_b</i>	<i>L_c</i>
FSS2010N1D0600	20	10	8 790	18 500	400	451	45	518	540	600	22
FSS2010N1D1000					800	851		918	940	1 000	
FSS2010N1D1450					1 250	1 301		1 368	1 390	1 450	
FSS2020N1D0600		20	5 900	11 700	400	442	54	518	540	600	
FSS2020N1D1000					800	842		918	940	1 000	
FSS2020N1D1450					1 250	1 292		1 368	1 390	1 450	

- Notes: 1. Indicates ball screw preload control value. Approximately 2.0 N·cm of torque is added due to thin plastic seals.
 2. Service temperature range is 0 to 80°C.
 3. Use of NSK support unit is recommended. See page B389 for details.

Lead accuracy			Shaft run-out <i>C</i>	Dynamic preload torque (N·cm)	Mass (kg)	Permissible rotational speed (min ⁻¹) ^{4,5} Fixed-Simple	Internal spatial volume of nut (cm ³)	Standard volume of grease replenishing (cm ³)
Target value <i>T</i>	Error <i>e_p</i>	Variation <i>V₃₀₀</i>						
0	0.195	0.052	0.085	-	1.7	5 000	3.2	1.6
	0.310		0.125		2.6	3 310		
	0.490		0.200		3.6	1 450		
	0.195		0.085		1.8	5 000		
	0.310		0.125		2.7	3 350		
	0.490		0.200		3.8	1 460		

4. The stroke and permissible rotational speed shown in the table are the values when the support unit recommended by NSK is used and Fixed-Supported (ball screw mounting method) is selected.
 5. Permissible rotational speed varies when using cut screw shaft. It is necessary to calculate two items below, and whichever smaller is the permissible rotational speed.
 *Critical speed which is the resonance vibration of the shaft (page B47).
 *Maximum rotational speed 5 000 min⁻¹

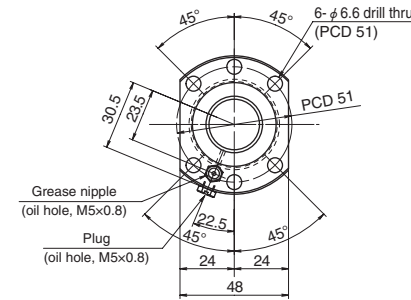
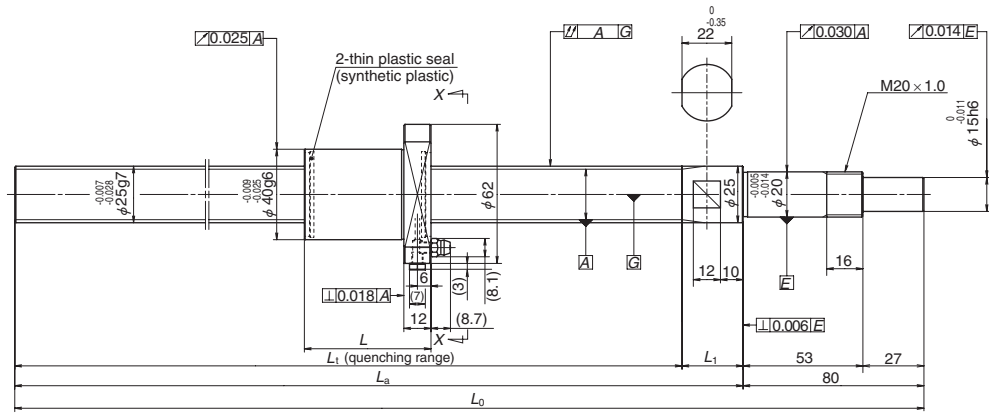

Ball screw specification

Ball diameter/screw shaft root diameter	3.175 / 22.2
Accuracy grade/axial play	Ct7 / 0.010 or less
Factory-packed grease	NSK grease LR3

Recommended support unit

For drive side (Fixed)	For opposite to drive side (Simple)
WBK20-01 (square)	WBK25SF-01 (square)

Ball screw No.	Screw shaft diameter <i>d</i>	Lead <i>l</i>	Basic load ratings (N)		Stroke		Nut length <i>L</i>	Screw shaft dimensions			
			Dynamic <i>C_d</i>	Static <i>C_{st}</i>	Nominal	Max.		<i>L₁</i>	<i>L_a</i>	<i>L_o</i>	<i>L₁</i>
FSS2510N1D0600	25	10	12 800	32 300	400	415	56	493	520	600	27
FSS2510N1D1000					800	815		893	920	1 000	
FSS2510N1D1450					1 250	1 265		1 343	1 370	1 450	
FSS2520N1D0600	25	20	6 560	14 600	400	418	54	494	520	600	26
FSS2520N1D1000					800	818		894	920	1 000	
FSS2520N1D1450					1 250	1 268		1 344	1 370	1 450	
FSS2525N1D0600	25	25	6 560	14 600	400	405	63	490	520	600	30
FSS2525N1D1000					800	805		890	920	1 000	
FSS2525N1D1450					1 250	1 255		1 340	1 370	1 450	

- Notes: 1. Indicates ball screw preload control value. Approximately 2.0 N-cm of torque is added due to thin plastic seals.
 2. Service temperature range is 0 to 80°C.
 3. Use of NSK support unit is recommended. See page B389 for details.

Lead accuracy			Shaft run-out <i>C</i>	Dynamic preload torque (N-cm)	Mass (kg)	Permissible rotational speed (min ⁻¹) ^{*)}	Internal spatial volume of nut (cm ³)	Standard volume of grease replenishing (cm ³)	
Target value <i>T</i>	Error <i>e_p</i>	Variation <i>V₃₀₀</i>							
0	0.155	0.052	0.065	-	2.6	5 000	4.7	2.4	
			0.090						
			0.130						
	0.310	0.090	0.130		0.065	2.6	5 000	3.9	2.0
					0.090	4.0	4 570		
					0.130	5.8	1 960		
	0.490	0.065	0.130		0.065	2.6	5 000	4.3	2.2
					0.090	4.1	4 660		
					0.130	5.8	1 990		

4. The stroke and permissible rotational speed shown in the table are the values when the support unit recommended by NSK is used and Fixed-Supported (ball screw mounting method) is selected.
 5. Permissible rotational speed varies when using cut screw shaft. It is necessary to calculate two items below, and whichever smaller is the permissible rotational speed.
 *)Critical speed which is the resonance vibration of the shaft (page B47).
 *)Maximum rotational speed 5 000 min⁻¹

B-3-1.2 High Speed SS Series HSS Type

◆ **Features**

The HMS and HMD series, originally developed for machine tools, are an addition to NSK's lineup of standard ball screws. They have a wide range of applications, from general machines to high performance machines such as those requiring high speed and precision.

● **High speed**

The new recirculation system that utilizes NSK's high speed and low noise technology more than doubles the $d \cdot n$ value from 70 000 to 160 000.

To extend the range of the lead to 20mm, high speed operation of over 60m/min. is possible.

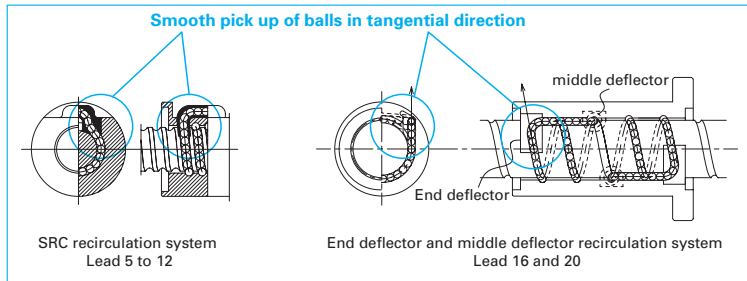

Fig 1 Ball recirculation system

Table 1 Allowable feed speed of combinations of shaft diameter and lead

shaft diameter [mm]	Lead [mm]	5	10	12	16	20
32		25m/min	50m/min			
40			40m/min	48m/min	64m/min	80m/min
45			35m/min			
50			32m/min	38m/min		

* Allowable speed needs to be calculated. See the permissible rotational speed in the dimensions table.

● **Low noise and vibrations**

Compared to our conventional products, the average noise level has been reduced by more than 6dB, reducing the number of colliding balls and recirculation parts thanks to high speed, low noise technology.

The vibration level of the nut has also been reduced drastically.

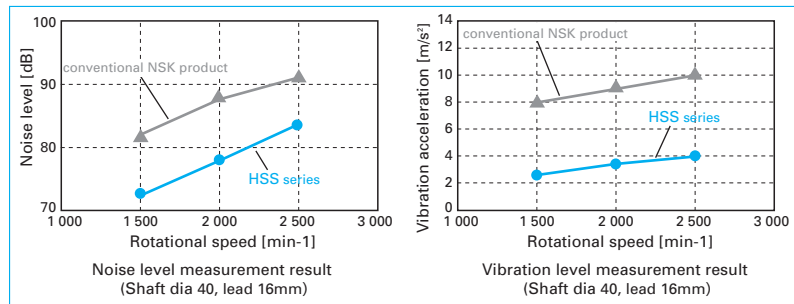

Table 2

● **Installation**

Installation dimension are the same as those of a conventional SS series.

● **Compact**

Achieved high-level stiffness and high load capacity equivalent to that of double nut preload by changing the double nut preload to the offset preload of a single nut, and compact sized nut. Adopted thin seals axially and shorten nut length.

● **Blank shaft ends**

The blank shaft ends can be customized according to customers' requests. See page B27 in NSK's recommended design when drawing up plans for a shaft end. The support units available on page B389 in the case of NSK's recommended design. See "Technical Description: Shaft End Processing" (page B86) for procedures of shaft end processing and precautions.

● **Oil supply**

2 oil holes, M6x1.0, are provided in the nut flange periphery are the end of the nut flange. A plug is standardly screwed into the periphery of the nut flange.

◆ **Specifications**

● **Accuracy grade and axial play**

The available standard accuracy grade and axial play are show in Table 2.

Table 2 Accuracy grade and axial play

Accuracy grade	C5
Axial play	0 mm (preloaded)

● **Dimension tables**

Shape dimensions and specifications are listed for every shaft diameter and lead. See Table 3, the "List of pages".

◆ **Other**

The seal of the ball screw and recirculation parts are made of synthetic resin. Consult NSK when using the ball screws under extreme environments or special environments, or using special lubricant or oil.

For special environments, see pages B70 and D2. See pages B67 and D13 for lubricants.

Table 3 Combinations of screw shaft diameter and lead

Screw shaft diameter [mm]	Lead [mm]	5	10	12	16	20
32		B149	B149			
40			B151	B151	B153	B153
45			B155			
50			B155	B155		

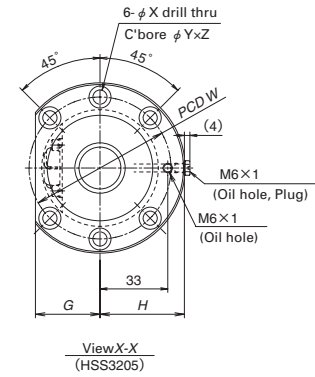
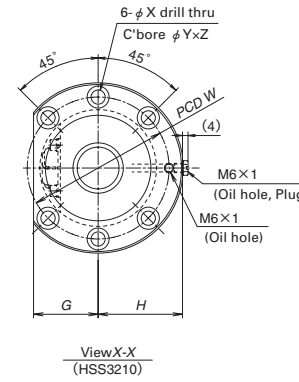
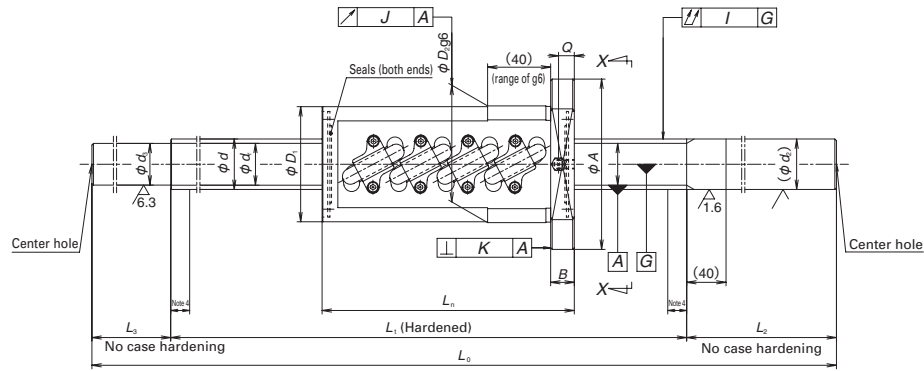

Reference No.	Screw shaft dia. <i>d</i>	Lead <i>l</i>	Ball dia. <i>D_w</i>	Ball circle dia. <i>d_m</i>	Root dia. <i>d_r</i>	Effective balls turns Tune x Circuits	Basic load rating(N)			Dynamic friction torque, median (N·cm)	Ball nut dimensions							
							Dynamic <i>C_d</i>	Static <i>C_{oa}</i>	Preload (N)		Diamete		Flange			Overall length <i>L_n</i>	<i>W</i>	
											<i>D₁</i>	<i>D₂</i>	<i>A</i>	<i>G</i>	<i>H</i>			<i>B</i>
HSS3205N1D0650	32	5	3.175	32.5	29.2	2.5X2	18500	56100	920	17.0	57	58	85	32	42	13	89	71
HSS3205N1D0950																		
HSS3205N1D1250																		
HSS3205N1D1550																		
HSS3205N1D1850																		
HSS3210N1D0850	32	10	6.350	33.0	26.4	2.5X2	46300	108000	2310	59.5	73	74	108	41	53.5	15	160	90
HSS3210N1D1050																		
HSS3210N1D1450																		
HSS3210N1D1850																		
HSS3210N1D2250																		

- Notes: 1. Service temperature range is 0 to 60°C.
 2. Use of NSK support unit is recommended. See page B389 for details.
 3. Only rust preventive agent is applied at time of delivery. Please apply lubricant (oil or grease) before use. See page D13 for details.
 4. Imperfect hardened areas for one lead exists on both ends of a screw. Exercise care when stroke setting.
 5. Permissible rotational speed: Calculated values obtained from the critical speed between the threaded length and NSK's recommended shaft end design. See page B27.

Bolt hole				Screw shaft dimension						Lead accuracy			Run-out			Permissible rotational speed (min ⁻¹)		Internal spatial volume of nut (cm ³)	Standard volume of grease replenishing (cm ³)	
				Oil hole	Threaded length	Shaft end, right	Shaft end, left	Overall length	Travel compensation	Deviation	Variation	Shaft straightness	Nut O.D. eccentricity	Flange perpendicularity	Mass (kg)	Installation				
<i>X</i>	<i>Y</i>	<i>Z</i>	<i>Q</i>	<i>L₁</i>	<i>d₂</i>	<i>L₂</i>	<i>d₃</i>	<i>L₃</i>	<i>L₀</i>	<i>T</i>	<i>e_p</i>	<i>V_u</i>	<i>I</i>	<i>J</i>		<i>K</i>	Fixed-Free support	Fixed-Fixed support		
6.6	11	6.5	8	400	200	50	650	-0.010	0.025	0.020	0.055	0.019	0.013	5.2	5000	5000	10	5		
				600	250	100	950	-0.014	0.030	0.023	0.065			7.0	5000	5000				
				900	32	250	29.2	100	1250	-0.022	0.040			0.027	0.080	8.7			5000	5000
				1150	300	100	1550	-0.028	0.046	0.030	0.100			10.5	3500	4700				
				1450	300	100	1850	-0.035	0.054	0.035	0.130			12.2	2200	2900				
9	14	8.5	10	500	250	100	850	-0.012	0.027	0.020	0.065	0.019	0.013	8.9	5000	5000	43	22		
				700	250	100	1050	-0.017	0.035	0.025	0.080			10.0	5000	5000				
				1050	32	300	26.4	100	1450	-0.025	0.046			0.030	0.100	12.2			4100	5000
				1450	300	100	1850	-0.035	0.054	0.035	0.130			14.3	2100	2800				
				1850	300	100	2250	-0.045	0.065	0.040	0.170			16.5	1200	1700				

Unit : mm

SSH

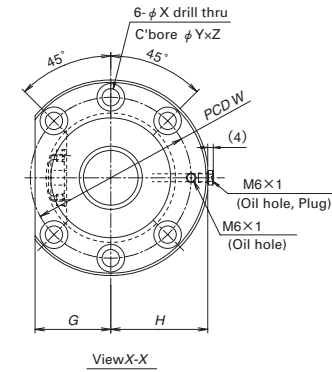
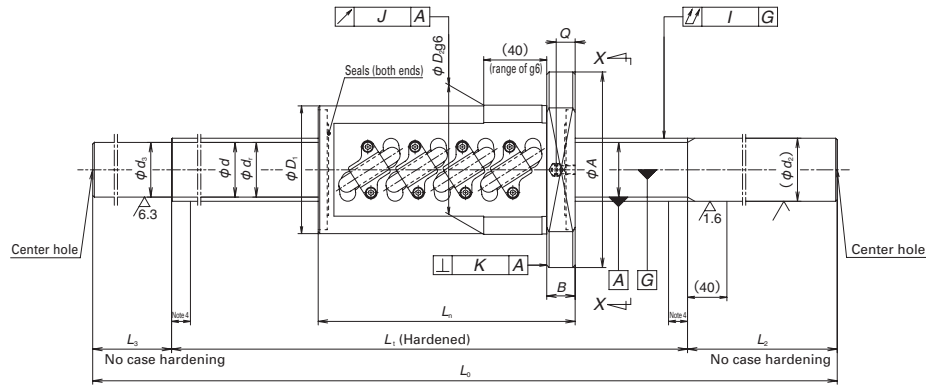

Reference No.	Screw shaft dia. <i>d</i>	Lead <i>l</i>	Ball dia. <i>D_w</i>	Ball circle dia. <i>d_m</i>	Root dia. <i>d_r</i>	Effective balls turns Tune × Circuits	Basic load rating(N)			Dynamic friction torque, median (N·cm)	Ball nut dimensions							
							Dynamic <i>C_d</i>	Static <i>C_{oa}</i>	Preload (N)		Diamete		Flange			Overall length <i>L_n</i>	<i>W</i>	
											<i>D₁</i>	<i>D₂</i>	<i>A</i>	<i>G</i>	<i>H</i>			<i>B</i>
HSS4010N1D0950	40	10	6.350	41.0	34.4	2.5X2	52000	137000	2600	74.5	81	82	124	47	61.5	18	163	102
HSS4010N1D1450																		
HSS4010N1D2100																		
HSS4010N1D2900																		
HSS4012N1D1450	40	12	7.144	41.5	34.1	2.5X2	61000	155000	3050	96.0	85	86	128	48	63.5	18	187	106
HSS4012N1D2100																		
HSS4012N1D2900																		

- Notes: 1. Service temperature range is 0 to 60°C.
 2. Use of NSK support unit is recommended. See page B389 for details.
 3. Only rust preventive agent is applied at time of delivery. Please apply lubricant (oil or grease) before use. See page D13 for details.
 4. Imperfect hardened areas for one lead exists on both ends of a screw. Exercise care when stroke setting.
 5. Permissible rotational speed: Calculated values obtained from the critical speed between the threaded length and NSK's recommended shaft end design. See page B27.

Bolt hole			Oil hole	Screw shaft dimension					Lead accuracy			Run-out			Mass (kg)	Permissible rotational speed (min ⁻¹)		Internal spatial volume of nut (cm ³)	Standard volume of grease replenishing (cm ³)
				Threaded length	Shaft end, right	Shaft end, left	Overall length	Travel compensation	Deviation	Variation	Shaft straightness	Nut O.D. eccentricity	Flange perpendicularity	Installation					
<i>X</i>	<i>Y</i>	<i>Z</i>	<i>Q</i>	<i>L₁</i>	<i>d₂</i>	<i>L₂</i>	<i>d₃</i>	<i>L₃</i>	<i>L₀</i>	<i>T</i>	<i>e_p</i>	<i>V_u</i>	<i>I</i>	<i>J</i>		<i>K</i>	Fixed-Free support		
11	17.5	11	12	600	250	100	950	-0.014	0.030	0.023	0.050	0.025	0.015	13.5	4000	4000	52	26	
				1050	300	100	1450	-0.025	0.046	0.030	0.070			17.9	4000	4000			
				1600	350	150	2100	-0.039	0.054	0.035	0.110			23.5	2200	3000			
				2400	350	150	2900	-0.058	0.077	0.046	0.140			30.5	900	1300			
11	17.5	11	12	1050	300	100	1450	-0.025	0.046	0.030	0.070	0.025	0.015	19.1	4000	4000	67	34	
				1600	350	150	2100	-0.039	0.054	0.035	0.110			24.8	2200	3000			
				2400	350	150	2900	-0.058	0.077	0.046	0.140			31.8	900	1300			

Unit : mm

SSH

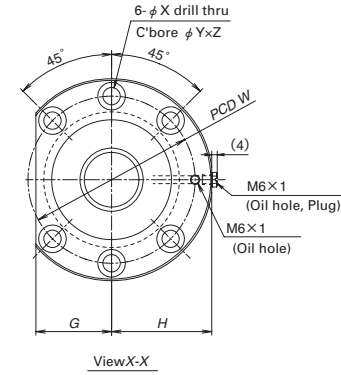
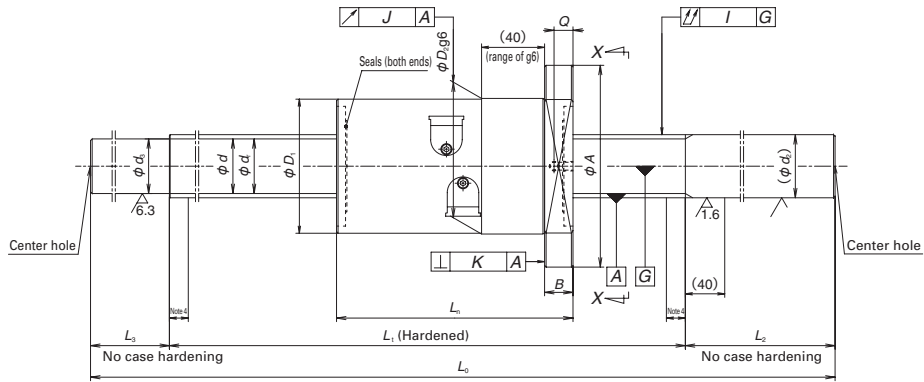

Reference No.	Screw shaft dia. <i>d</i>	Lead <i>l</i>	Ball dia. <i>D_w</i>	Ball circle dia. <i>d_m</i>	Root dia. <i>d_r</i>	Effective balls turns Tune × Circuits	Basic load rating (N)			Dynamic friction torque, median (N·cm)	Ball nut dimensions							
							Dynamic <i>C_d</i>	Static <i>C_{oa}</i>	Preload (N)		Diameter		Flange			Overall length <i>L_n</i>	<i>W</i>	
											<i>D₁</i>	<i>D₂</i>	<i>A</i>	<i>G</i>	<i>H</i>			<i>B</i>
HSS4016N1D1450	40	16	7.144	41.5	34.1	3.7X1	57100	130000	2850	104.0	85	86	128	48	63.5	18	160	106
HSS4016N1D2100																		
HSS4016N1D2900																		
HSS4020N1D1450	40	20	7.144	41.5	34.1	3.7X1	57100	130000	2850	116.5	85	86	128	48	63.5	18	192	106
HSS4020N1D2100																		
HSS4020N1D2900																		

- Notes: 1. Service temperature range is 0 to 60°C.
 2. Use of NSK support unit is recommended. See page B389 for details.
 3. Only rust preventive agent is applied at time of delivery. Please apply lubricant (oil or grease) before use. See page D13 for details.
 4. Imperfect hardened areas for one lead exists on both ends of a screw. Exercise care when stroke setting.
 5. Permissible rotational speed: Calculated values obtained from the critical speed between the threaded length and NSK's recommended shaft end design. See page B27.

Bolt hole			Oil hole	Screw shaft dimension					Lead accuracy			Run-out			Mass (kg)	Permissible rotational speed (min ⁻¹)		Internal spatial volume of nut (cm ³)	Standard volume of grease replenishing (cm ³)		
				Threaded length	Shaft end, right	Shaft end, left	Overall length	Travel compensation	Deviation	Variation	Shaft straightness	Nut O.D. eccentricity	Flange perpendicularity	Installation							
<i>X</i>	<i>Y</i>	<i>Z</i>	<i>Q</i>	<i>L₁</i>	<i>d₂</i>	<i>L₂</i>	<i>d₃</i>	<i>L₃</i>	<i>L₀</i>	<i>T</i>	<i>e_p</i>	<i>V_u</i>	<i>I</i>	<i>J</i>	<i>K</i>	Fixed-Free support	Fixed-Fixed support				
11	17.5	11	11	1050	300	100	1450	-0.025	0.046	0.030	0.070	0.025	0.015	19.2	4000	4000	40	20			
				1600	40	350	34.1	150	2100	-0.039	0.054				0.035	0.110			25.0	2200	3000
				2400	350	150	2900	-0.058	0.077	0.046	0.140				32.2	900			1300		
11	17.5	11	11	1050	300	100	1450	-0.025	0.046	0.030	0.070	0.025	0.015	20.3	4000	4000	47	24			
				1600	40	350	34.4	150	2100	-0.039	0.054				0.035	0.110			26.2	2200	3000
				2400	350	150	2900	-0.058	0.077	0.046	0.140				33.5	900			1300		

Unit : mm

SSH

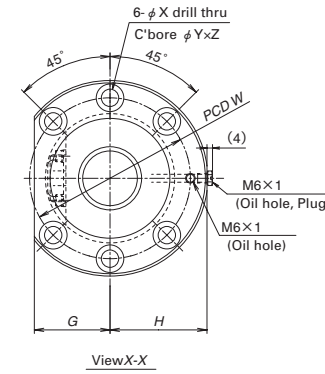
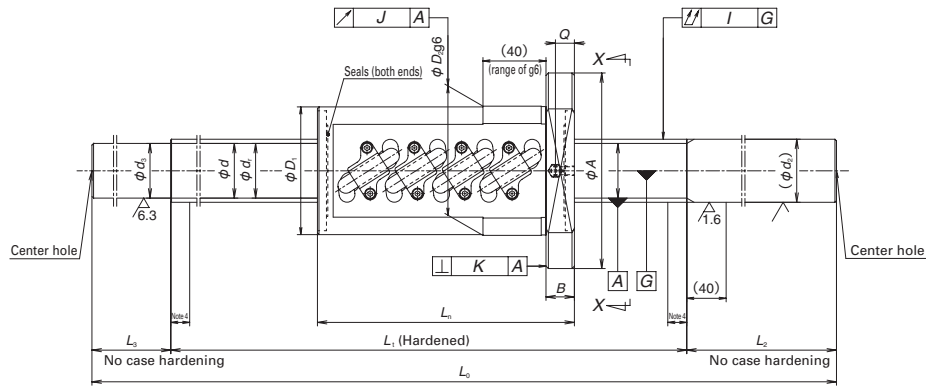

Reference No.	Screw shaft dia. <i>d</i>	Lead <i>l</i>	Ball dia. <i>D_w</i>	Ball circle dia. <i>d_m</i>	Root dia. <i>d_r</i>	Effective balls turns Tune x Circuits	Basic load rating (N)			Dynamic friction torque, median (N·cm)	Ball nut dimensions							
							Dynamic <i>C_d</i>	Static <i>C_{oa}</i>	Preload (N)		Diameter		Flange			Overall length <i>L_n</i>	<i>W</i>	
											<i>D₁</i>	<i>D₂</i>	<i>A</i>	<i>G</i>	<i>H</i>			<i>B</i>
HSS4510N1D1450	45	10	6.350	46.0	39.4	2.5X2	54200	155000	2710	82.0	87	88	132	50	65.5	18	163	110
HSS4510N1D2100																		
HSS4510N1D2900																		
HSS5010N1D1450	50	10	6.350	51.0	44.4	2.5X2	57700	175000	2880	92.0	92	93	135	51	67	18	163	113
HSS5010N1D1850																		
HSS5010N1D2350																		
HSS5010N1D2900																		
HSS5012N1D1450																		
HSS5012N1D2100	50	12	7.938	51.5	43.2	2.5X2	77600	214000	3880	136.5	99	100	146	55	72.5	22	193	122
HSS5012N1D2900																		

- Notes: 1. Service temperature range is 0 to 60°C.
 2. Use of NSK support unit is recommended. See page B389 for details.
 3. Only rust preventive agent is applied at time of delivery. Please apply lubricant (oil or grease) before use. See page D13 for details.
 4. Imperfect hardened areas for one lead exists on both ends of a screw. Exercise care when stroke setting.
 5. Permissible rotational speed: Calculated values obtained from the critical speed between the threaded length and NSK's recommended shaft end design. See page B27.

Bolt hole <i>X</i>	<i>Y</i>	<i>Z</i>	Oil hole <i>Q</i>	Screw shaft dimension						Lead accuracy			Run-out			Mass (kg)	Permissible rotational speed (min ⁻¹)		Internal spatial volume of nut (cm ³)	Standard volume of grease replenishing (cm ³)
				Threaded length <i>L₁</i>	Shaft end, right		Shaft end, left		Overall length <i>L₀</i>	Travel compensation <i>T</i>	Deviation <i>e_p</i>	Variation <i>V_u</i>	Shaft straightness <i>I</i>	Nut O.D. eccentricity <i>J</i>	Flange perpendicularity <i>K</i>		Installation			
					<i>d₂</i>	<i>L₂</i>	<i>d₃</i>	<i>L₃</i>									Fixed-Free support	Fixed-Fixed support		
11	17.5	11	12	1050	300	100	1450	-0.025	0.046	0.030	0.070	0.025	0.015	22.0	3500	3500	58	29		
				1600	45	350	39.4	150	2100	-0.039	0.054			0.035	0.110	29.2			2500	3400
				2400	350	150	2900	-0.058	0.077	0.046	0.140			38.2	1100	1500				
11	17.5	11	12	1050	300	100	1450	-0.025	0.046	0.030	0.070	0.025	0.015	26.3	3200	3200	64	32		
				1450	300	100	1850	-0.035	0.054	0.035	0.090			31.9	3200	3200				
				1850	350	44.4	150	2350	-0.045	0.065	0.040			0.110	38.8	2100			2900	
				2400	350	150	2900	-0.058	0.077	0.046	0.140			46.5	1200	1700				
14	20	13	12	1050	300	100	1450	-0.025	0.046	0.030	0.070	0.025	0.015	28.5	3200	3200	99	50		
				1600	50	350	43.2	150	2100	-0.039	0.054			0.035	0.110	37.3			2800	3200
				2400	350	150	2900	-0.058	0.077	0.046	0.140			48.2	1200	1600				

Unit : mm

SSH

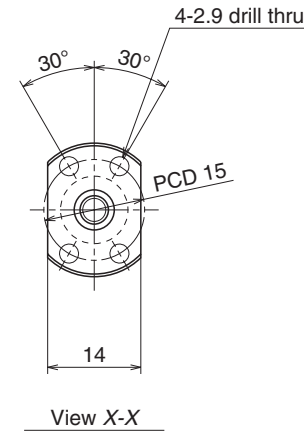
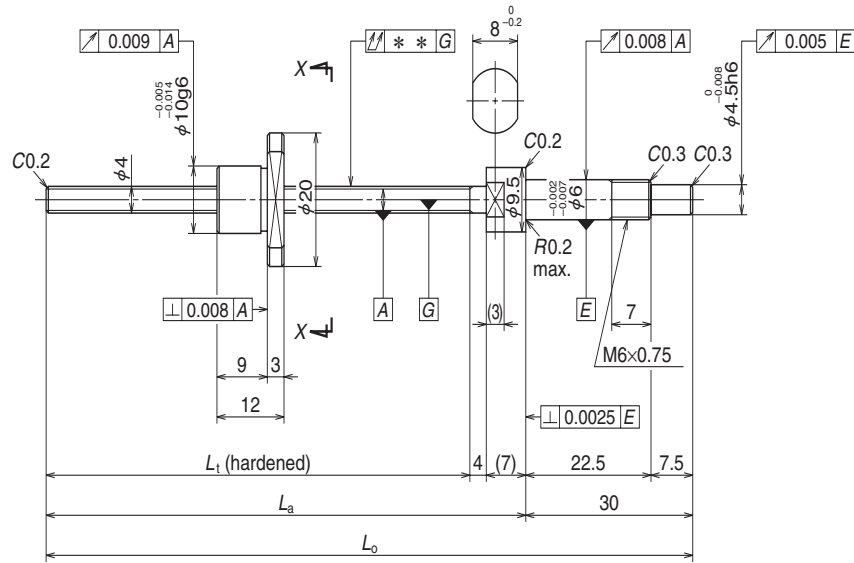

Ball screw specifications		
Product classification	Preloaded	Precise clearance
Shaft dia. x Lead / Direction of turn	4 × 1 / Right	
Preload / Ball recirculation	P-preload / Deflector (bridge type)	
Ball dia. / Ball circle dia.	0.800 / 4.2	
Screw shaft root diameter	3.2	
Effective turns of balls	1 × 2	
Accuracy grade / Preload / Axial play	C3 / Z	C3 / T
Basic load rating (N)	Dynamic C _a	315
	Static C _{0a}	370
Axial play	0	0.005 or less
Preload (N)	19.6	—
Dynamic friction torque, (N-cm)	1.0 or less	0.3 or less
Spacer ball	None	
Factory-packed grease	NSK grease PS2	

Recommended support unit

For drive side (Fixed)	
WBK06-01A (square)	
WBK06-11 (round)	

Unit: mm

Ball screw No.		Stroke	
		Nominal	Maximum
Preloaded (MPFD)	Precise clearance (MSFD)		
W0400MA-1PY-C3Z1	W0400MA-2Y-C3T1	20	32
W0400MA-3PY-C3Z1	W0400MA-4Y-C3T1	40	52
W0401MA-1PY-C3Z1	W0401MA-2Y-C3T1	70	82

Screw shaft length			Lead accuracy			Shaft run-out **	Mass (kg)	Permissible rotational speed N (min ⁻¹)
L _t	L _a	L _o	T	e _p	v _u			Supporting condition
								Fixed - Free
44	55	85	0	0.008	0.008	0.015	0.024	3 000
64	75	105	0	0.008	0.008	0.020	0.026	3 000
94	105	135	0	0.008	0.008	0.025	0.028	3 000

- Notes:
1. We recommend NSK support unit. See page B389 for details.
 2. Use of NSK grease PS2 is recommended. Apply to screw shaft surface when replenishing. See page D16 for details.
 3. Ball nut does not have seal.
 4. Contact NSK if the permissible rotational speed is to be exceeded.

Finished shaft end MA Type

(Fine lead)

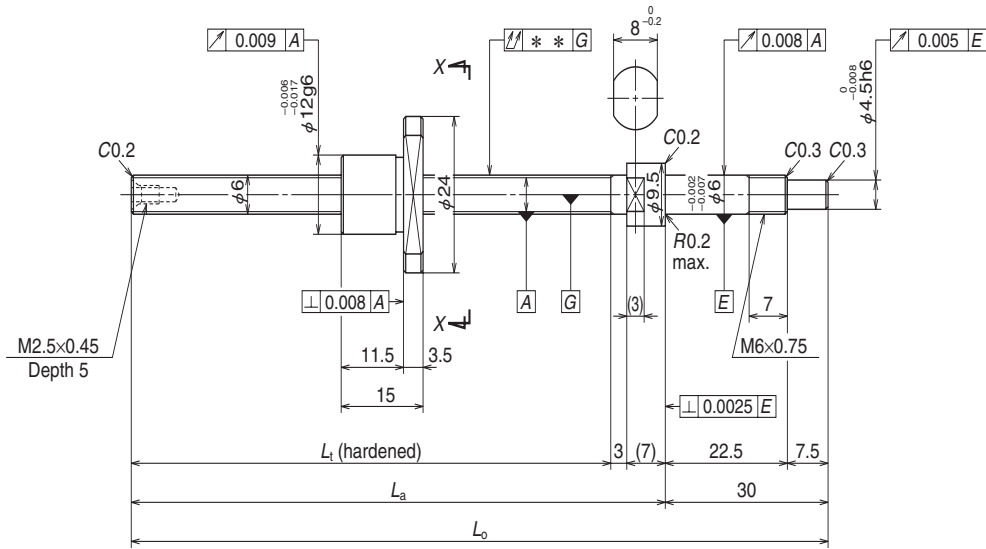

Nut models: MPFD, MSFD

NSK

Screw shaft ø6

Lead 1

Unit: mm

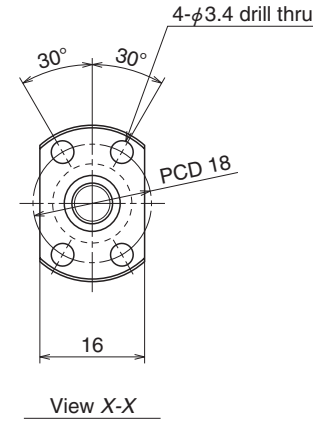

Ball screw specifications		
Product classification	Preloaded	Precise clearance
Shaft dia. x Lead / Direction of turn	6 × 1 / Right	
Preload / Ball recirculation	P-preload / Deflector (bridge)	
Ball dia. / Ball circle dia.	0.800 / 6.2	
Screw shaft root diameter	5.2	
Effective turns of balls	1 × 3	
Accuracy grade / Preload / Axial play	C3 / Z	C3 / T
Basic load rating (N)	Dynamic C_d	575
	Static C_0	925
Axial play	0	0.005 or less
Preload (N)	24.5	—
Dynamic friction torque, (N-cm)	1.3 or less	0.3 or less
Spacer ball	None	
Factory-packed grease	NSK grease PS2	

Recommended support unit

For drive side (Fixed)	
WBK06-01A (square)	
WBK06-11 (round)	

Unit: mm

Ball screw No.		Stroke	
		Nominal	Maximum
Preloaded (MPFD)	Precise clearance (MSFD)		
W0600MA-1PY-C3Z1	W0600MA-2Y-C3T1	40	50
W0601MA-1PY-C3Z1	W0601MA-2Y-C3T1	70	80
W0601MA-3PY-C3Z1	W0601MA-4Y-C3T1	100	110

- Notes:
1. We recommend NSK support unit. See page B389 for details.
 2. Use of NSK grease PS2 is recommended. Apply to screw shaft surface when replenishing. See page D16 for details.
 3. Ball nut does not have seal.
 4. Contact NSK if the permissible rotational speed is to be exceeded.

Screw shaft length			Lead accuracy			Shaft run-out **	Mass (kg)	Permissible rotational speed N (min ⁻¹)
L_t	L_a	L_o	T	e_p	v_u			Supporting condition
								Fixed - Free
65	75	105	0	0.008	0.008	0.015	0.039	3 000
95	105	135	0	0.008	0.008	0.020	0.045	3 000
125	135	165	0	0.010	0.008	0.025	0.051	3 000

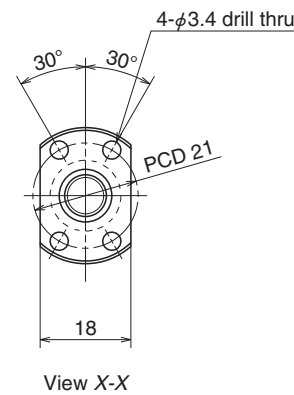
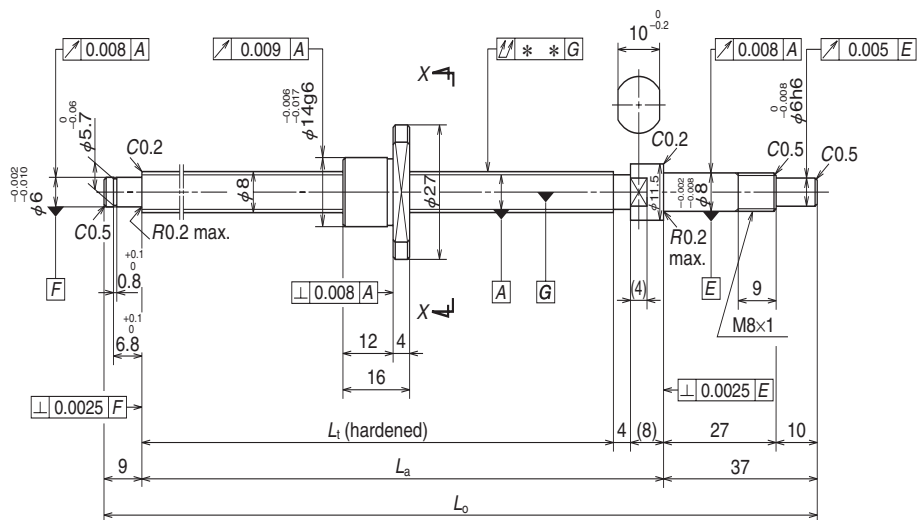

Ball screw specifications		
Product classification	Preloaded	Precise clearance
Shaft dia. x Lead / Direction of turn	8 x 1 / Right	
Preload / Ball recirculation	P-preload / Deflector (bridge)	
Ball dia. / Ball circle dia.	0.800 / 8.2	
Screw shaft root diameter	7.2	
Effective turns of balls	1 x 3	
Accuracy grade / Preload / Axial play	C3 / Z	C3 / T
Basic load rating (N)	Dynamic C_d	670
	Static C_0	1 290
Axial play	0	0.005 or less
Preload (N)	29.4	—
Dynamic friction torque, (N-cm)	1.8 or less	0.5 or less
Spacer ball	None	
Factory-packed grease	NSK grease PS2	

Recommended support unit

For drive side (Fixed)	For opposite to drive side (Simple)
WBK08-01A (square)	WBK08S-01 (square)
WBK08-11 (round)	

Unit: mm

Ball screw No.		Stroke	
		Nominal	Maximum
Preloaded (MPFD)	Precise clearance (MSFD)		
W0800MA-1PY-C3Z1	W0800MA-2Y-C3T1	40	59
W0801MA-1PY-C3Z1	W0801MA-2Y-C3T1	70	89
W0801MA-3PY-C3Z1	W0801MA-4Y-C3T1	100	119
W0802MA-1PY-C3Z1	W0802MA-2Y-C3T1	150	169

Screw shaft length			Lead accuracy			Shaft run-out **	Mass (kg)	Permissible rotational speed N (min ⁻¹)
L_t	L_a	L_o	T	e_p	v_u			Supporting condition
80	92	138	0	0.008	0.008	0.025	0.073	3 000
110	122	168	0	0.010	0.008	0.030	0.084	3 000
140	152	198	0	0.010	0.008	0.030	0.095	3 000
190	202	248	0	0.010	0.008	0.035	0.11	3 000

- Notes: 1. We recommend NSK support unit. See page B389 for details.
 2. Use of NSK grease PS2 is recommended. Apply to screw shaft surface when replenishing. See page D16 for details.
 3. Ball nut does not have seal.
 4. Contact NSK if the permissible rotational speed is to be exceeded.

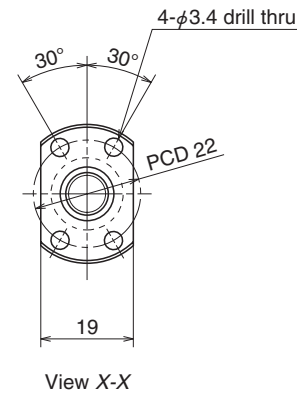
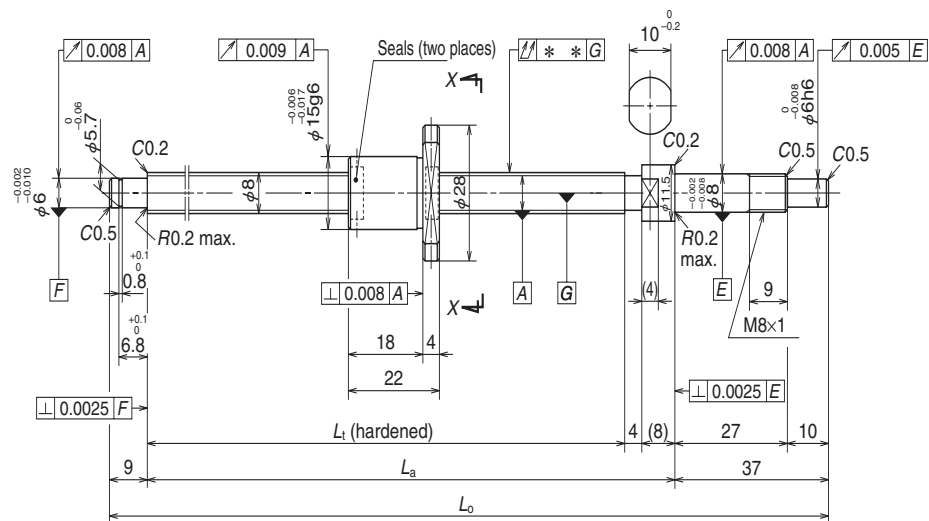

Ball screw specifications		
Product classification	Preloaded	Precise clearance
Shaft dia. x Lead / Direction of turn	8 × 1.5 / Right	
Preload / Ball recirculation	P-preload / Deflector (bridge)	
Ball dia. / Ball circle dia.	1.000 / 8.3	
Screw shaft root diameter	7.0	
Effective turns of balls	1 × 3	
Accuracy grade / Preload / Axial play	C3 / Z	C3 / T
Basic load rating (N)	Dynamic C_a	1 080
	Static C_{0a}	1 980
Axial play	0	0.005 or less
Preload (N)	49.0	—
Dynamic friction torque, (N-cm)	2.0 or less	0.5 or less
Spacer ball	None	
Factory-packed grease	NSK grease PS2	

Recommended support unit

For drive side (Fixed)	For opposite to drive side (Simple)
WBK08-01A (square)	WBK08S-01 (square)
WBK08-11 (round)	

Ball screw No.		Stroke	
		Nominal	Maximum
Preloaded (MPFD)	Precise clearance (MSFD)		
W0800MA-3PY-C3Z1.5	W0800MA-4Y-C3T1.5	40	53
W0801MA-5PY-C3Z1.5	W0801MA-6Y-C3T1.5	70	83
W0801MA-7PY-C3Z1.5	W0801MA-8Y-C3T1.5	100	113
W0802MA-3PY-C3Z1.5	W0802MA-4Y-C3T1.5	150	163

Screw shaft length			Lead accuracy			Shaft run-out **	Mass (kg)	Permissible rotational speed N (min ⁻¹)
L_t	L_a	L_o	T	e_p	v_u			
80	92	138	0	0.008	0.008	0.025	0.082	3 000
110	122	168	0	0.010	0.008	0.030	0.093	3 000
140	152	198	0	0.010	0.008	0.030	0.10	3 000
190	202	248	0	0.010	0.008	0.035	0.12	3 000

- Notes: 1. We recommend NSK support unit. See page B389 for details.
 2. Use of NSK grease PS2 is recommended. Apply to screw shaft surface when replenishing. See page D16 for details.
 3. Contact NSK if the permissible rotational speed is to be exceeded.

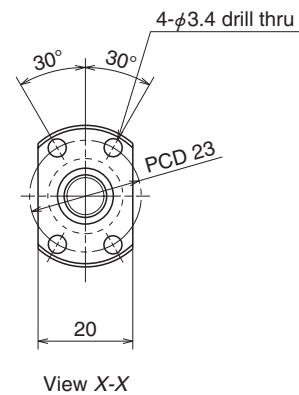
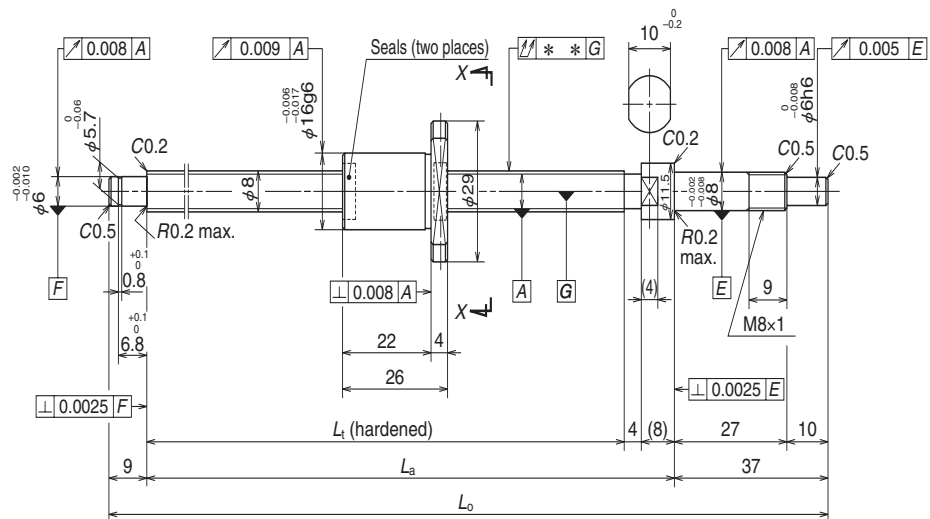

Ball screw specifications		
Product classification	Preloaded	Precise clearance
Shaft dia. x Lead / Direction of turn	8 x 2 / Right	
Preload / Ball recirculation	P-preload / Deflector (bridge)	
Ball dia. / Ball circle dia.	1.200 / 8.3	
Screw shaft root diameter	6.9	
Effective turns of balls	1 x 3	
Accuracy grade / Preload / Axial play	C3 / Z	C3 / T
Basic load rating (N)	Dynamic C_d	1 320
	Static C_0	2 210
Axial play	0	0.005 or less
Preload (N)	49.0	—
Dynamic friction torque, (N-cm)	2.0 or less	0.5 or less
Spacer ball	None	
Factory-packed grease	NSK grease PS2	

Recommended support unit

For drive side (Fixed)	For opposite to drive side (Simple)
WBK08-01A (square)	WBK08S-01 (square)
WBK08-11 (round)	

Unit: mm

Ball screw No.		Stroke	
		Nominal	Maximum
Preloaded (MPFD)	Precise clearance (MSFD)		
W0800MA-5PY-C3Z2	W0800MA-6Y-C3T2	40	49
W0801MA-9PY-C3Z2	W0801MA-10Y-C3T2	70	79
W0801MA-11PY-C3Z2	W0801MA-12Y-C3T2	100	109
W0802MA-5PY-C3Z2	W0802MA-6Y-C3T2	150	159

Screw shaft length			Lead accuracy			Shaft run-out **	Mass (kg)	Permissible rotational speed N (min ⁻¹)
L_t	L_a	L_o	T	e_p	v_u			
80	92	138	0	0.008	0.008	0.025	0.09	3 000
110	122	168	0	0.010	0.008	0.030	0.10	3 000
140	152	198	0	0.010	0.008	0.030	0.11	3 000
190	202	248	0	0.010	0.008	0.035	0.13	3 000

- Notes: 1. We recommend NSK support unit. See page B389 for details.
 2. Use of NSK grease PS2 is recommended. Apply to screw shaft surface when replenishing. See page D16 for details.
 3. Contact NSK if the permissible rotational speed is to be exceeded.

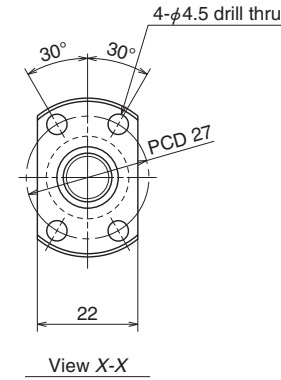
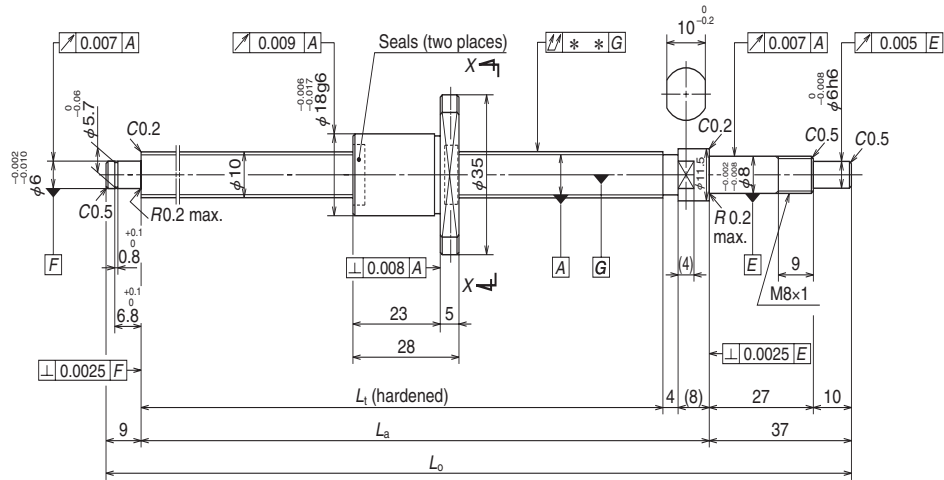

Ball screw specifications		
Product classification	Preloaded	Precise clearance
Shaft dia. x Lead / Direction of turn	10 x 2 / Right	
Preload / Ball recirculation	P-preload / Deflector (bridge)	
Ball dia. / Ball circle dia.	1.200 / 10.3	
Screw shaft root diameter	8.9	
Effective turns of balls	1 x 3	
Accuracy grade / Preload / Axial play	C3 / Z	C3 / T
Basic load rating (N)	Dynamic C_a	1 490
	Static C_{0a}	2 850
Axial play	0	0.005 or less
Preload (N)	58.8	—
Dynamic friction torque, (N-cm)	0.1 - 2.4	0.5 or less
Spacer ball	None	
Factory-packed grease	NSK grease PS2	

Recommended support unit

For drive side (Fixed)	For opposite to drive side (Simple)
WBK08-01A (square)	WBK08S-01 (square)
WBK08-11 (round)	

Unit: mm

Ball screw No.		Stroke	
		Nominal	Maximum
Preloaded (MPFD)	Precise clearance (MSFD)		
W1001MA-1PY-C3Z2	W1001MA-2Y-C3T2	50	67
W1001MA-3PY-C3Z2	W1001MA-4Y-C3T2	100	117
W1002MA-1PY-C3Z2	W1002MA-2Y-C3T2	150	167
W1002MA-3PY-C3Z2	W1002MA-4Y-C3T2	200	217

Screw shaft length			Lead accuracy			Shaft run-out **	Mass (kg)	Permissible rotational speed N (min ⁻¹)
L_t	L_a	L_o	T	e_p	v_u			Supporting condition
100	112	158	0	0.008	0.008	0.020	0.13	3 000
150	162	208	0	0.010	0.008	0.030	0.16	3 000
200	212	258	0	0.010	0.008	0.030	0.19	3 000
250	262	308	0	0.012	0.008	0.030	0.22	3 000

- Notes: 1. We recommend NSK support unit. See page B389 for details.
 2. Use of NSK grease PS2 is recommended. Apply to screw shaft surface when replenishing. See page D16 for details.
 3. Contact NSK if the permissible rotational speed is to be exceeded.

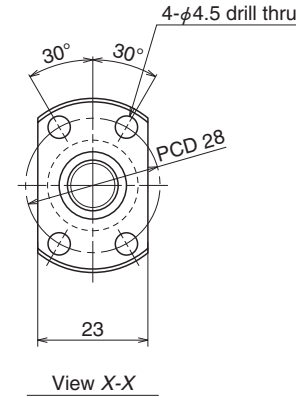
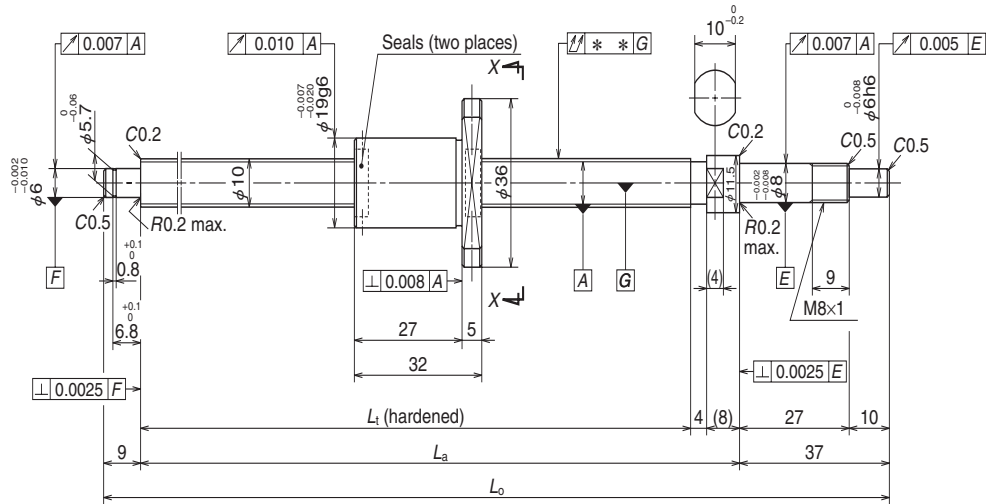

Ball screw specifications		
Product classification	Preloaded	Precise clearance
Shaft dia. x Lead / Direction of turn	10 x 2.5 / Right	
Preload / Ball recirculation	P-preload / Deflector (bridge)	
Ball dia. / Ball circle dia.	1.588 / 10.4	
Screw shaft root diameter	8.6	
Effective turns of balls	1 x 3	
Accuracy grade / Preload / Axial play	C3 / Z	C3 / T
Basic load rating (N)	Dynamic C_d	2 130
	Static C_0	3 640
Axial play	0	0.005 or less
Preload (N)	98.1	—
Dynamic friction torque, (N-cm)	0.2 - 2.9	0.5 or less
Spacer ball	None	
Factory-packed grease	NSK grease PS2	

Recommended support unit

For drive side (Fixed)	For opposite to drive side (Simple)
WBK08-01A (square)	WBK08S-01 (square)
WBK08-11 (round)	

Ball screw No.		Stroke	
		Nominal	Maximum
Preloaded (MPFD)	Precise clearance (MSFD)		
W1001MA-5PY-C3Z2.5	W1001MA-6Y-C3T2.5	50	63
W1001MA-7PY-C3Z2.5	W1001MA-8Y-C3T2.5	100	113
W1002MA-5PY-C3Z2.5	W1002MA-6Y-C3T2.5	150	163
W1002MA-7PY-C3Z2.5	W1002MA-8Y-C3T2.5	200	213

Screw shaft length			Lead accuracy			Shaft run-out **	Mass (kg)	Permissible rotational speed N (min ⁻¹)
L_t	L_a	L_o	T	e_p	v_u			Supporting condition
								Fixed - Simple support
100	112	158	0	0.008	0.008	0.020	0.14	3 000
150	162	208	0	0.010	0.008	0.030	0.17	3 000
200	212	258	0	0.010	0.008	0.030	0.20	3 000
250	262	308	0	0.012	0.008	0.030	0.23	3 000

- Notes: 1. We recommend NSK support unit. See page B389 for details.
 2. Use of NSK grease PS2 is recommended. Apply to screw shaft surface when replenishing. See page D16 for details.
 3. Contact NSK if the permissible rotational speed is to be exceeded.

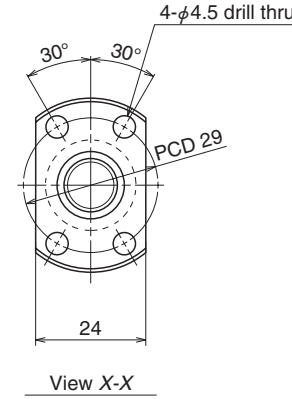
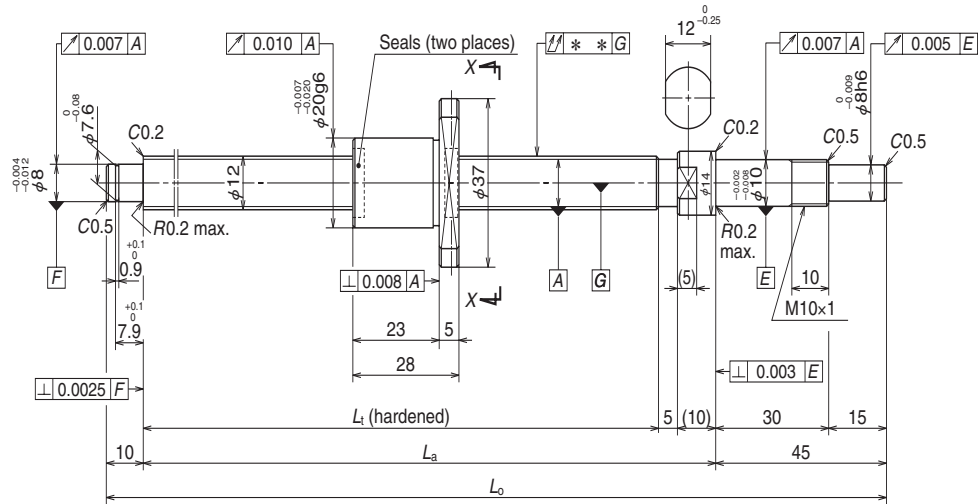

Ball screw specifications		
Product classification	Preloaded	Precise clearance
Shaft dia. x Lead / Direction of turn	12 x 2 / Right	
Preload / Ball recirculation	P-preload / Deflector (bridge)	
Ball dia. / Ball circle dia.	1.200 / 12.3	
Screw shaft root diameter	10.9	
Effective turns of balls	1 x 3	
Accuracy grade / Preload / Axial play	C3 / Z	C3 / T
Basic load rating (N)	Dynamic C_d	1 660
	Static C_0	3 620
Axial play	0	0.005 or less
Preload (N)	98.1	—
Dynamic friction torque, (N-cm)	0.4 - 3.4	1.0 or less
Spacer ball	None	
Factory-packed grease	NSK grease PS2	

Recommended support unit

For drive side (Fixed)	For opposite to drive side (Simple)
WBK10-01A (square)	WBK10S-01 (square)
WBK10-11 (round)	

Unit: mm

Ball screw No.		Stroke	
		Nominal	Maximum
Preloaded (MPFD)	Precise clearance (MSFD)		
W1201MA-1PY-C3Z2	W1201MA-2Y-C3T2	50	75
W1201MA-3PY-C3Z2	W1201MA-4Y-C3T2	100	125
W1202MA-1PY-C3Z2	W1202MA-2Y-C3T2	150	175
W1202MA-3PY-C3Z2	W1202MA-4Y-C3T2	200	225
W1203MA-1PY-C3Z2	W1203MA-2Y-C3T2	250	275

- Notes: 1. We recommend NSK support unit. See page B389 for details.
 2. Use of NSK grease PS2 is recommended. Apply to screw shaft surface when replenishing. See page D16 for details.
 3. Contact NSK if the permissible rotational speed is to be exceeded.

Screw shaft length			Lead accuracy			Shaft run-out **	Mass (kg)	Permissible rotational speed N (min ⁻¹)
L_t	L_a	L_o	T	e_p	v_u			
110	125	180	0	0.010	0.008	0.020	0.20	3 000
160	175	230	0	0.010	0.008	0.030	0.24	3 000
210	225	280	0	0.012	0.008	0.030	0.28	3 000
260	275	330	0	0.012	0.008	0.040	0.32	3 000
310	325	380	0	0.012	0.008	0.040	0.36	3 000

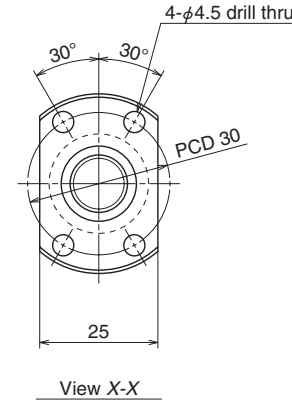
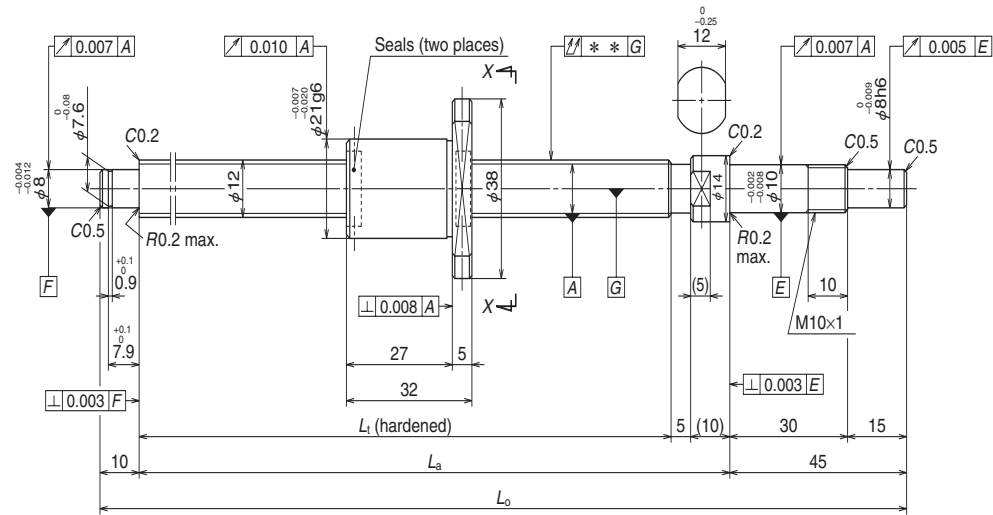

Ball screw specifications		
Product classification	Preloaded	Precise clearance
Shaft dia. x Lead / Direction of turn	12 x 2.5 / Right	
Preload / Ball recirculation	P-preload / Deflector (bridge)	
Ball dia. / Ball circle dia.	1.588 / 12.4	
Screw shaft root diameter	10.6	
Effective turns of balls	1 x 3	
Accuracy grade / Preload / Axial play	C3 / Z	C3 / T
Basic load rating (N)	Dynamic C_d	2 360
	Static C_0	4 540
Axial play	0	0.005 or less
Preload (N)	98.1	—
Dynamic friction torque, (N-cm)	0.4 - 3.4	1.0 or less
Spacer ball	None	
Factory-packed grease	NSK grease PS2	

Recommended support unit

For drive side (Fixed)	For opposite to drive side (Simple)
WBK10-01A (square)	WBK10S-01 (square)
WBK10-11 (round)	

Ball screw No.		Stroke	
		Nominal	Maximum
Preloaded (MPFD)	Precise clearance (MSFD)		
W1201MA-5PY-C3Z2.5	W1201MA-6Y-C3T2.5	50	71
W1201MA-7PY-C3Z2.5	W1201MA-8Y-C3T2.5	100	121
W1202MA-5PY-C3Z2.5	W1202MA-6Y-C3T2.5	150	171
W1202MA-7PY-C3Z2.5	W1202MA-8Y-C3T2.5	200	221
W1203MA-3PY-C3Z2.5	W1203MA-4Y-C3T2.5	250	271

- Notes: 1. We recommend NSK support unit. See page B389 for details.
 2. Use of NSK grease PS2 is recommended. Apply to screw shaft surface when replenishing. See page D16 for details.
 3. Contact NSK if the permissible rotational speed is to be exceeded.

Screw shaft length			Lead accuracy			Shaft run-out **	Mass (kg)	Permissible rotational speed N (min ⁻¹)
L_t	L_a	L_o	T	e_p	v_u			
110	125	180	0	0.010	0.008	0.020	0.21	3 000
160	175	230	0	0.010	0.008	0.030	0.25	3 000
210	225	280	0	0.012	0.008	0.030	0.29	3 000
260	275	330	0	0.012	0.008	0.040	0.33	3 000
310	325	380	0	0.012	0.008	0.040	0.37	3 000

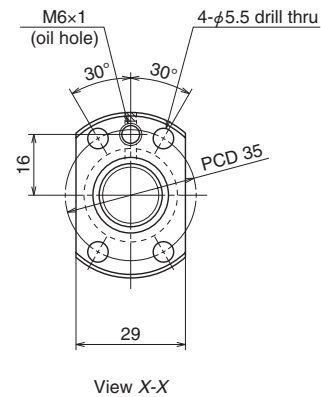
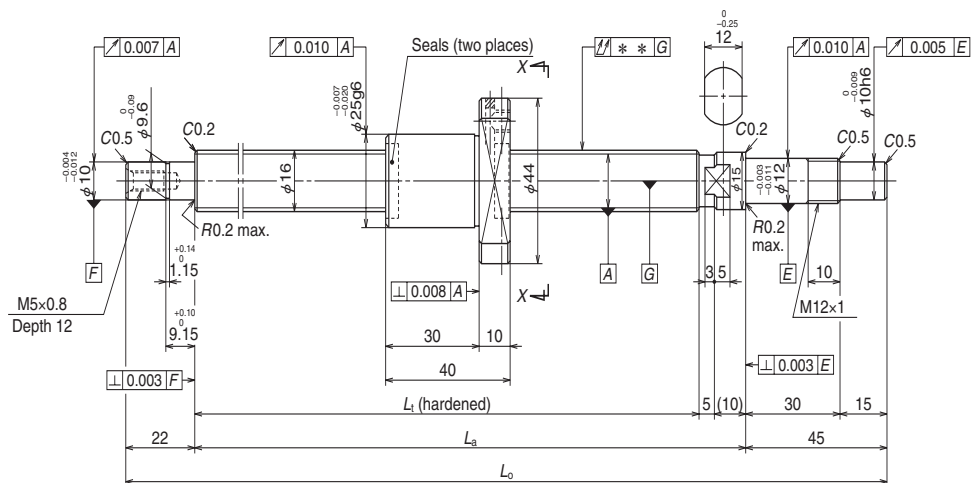

Ball screw specifications		
Product classification	Preloaded	Precise clearance
Shaft dia. x Lead / Direction of turn	16 x 2 / Right	
Preload / Ball recirculation	P-preload / Deflector (bridge)	
Ball dia. / Ball circle dia.	1.588 / 16.4	
Screw shaft root diameter	14.6	
Effective turns of balls	1 x 4	
Accuracy grade / Preload / Axial play	C3 / Z	C3 / T
Basic load rating (N)	Dynamic C_a	3 510
	Static C_{0a}	8 450
Axial play	0	0.005 or less
Preload (N)	147	—
Dynamic friction torque, (N-cm)	0.5 - 4.9	1.5 or less
Spacer ball	None	
Factory-packed grease	NSK grease PS2	
Internal spatial volume of nut (cm ³)	1.6	
Standard volume of grease replenishing (cm ³)	0.8	

Recommended support unit

For drive side (Fixed)	For opposite to drive side (Simple)
WBK12-01A (square)	WBK12S-01 (square)
WBK12-11 (round)	

Ball screw No.		Stroke	
		Nominal	Maximum
Preloaded (MPFD)	Precise clearance (MSFD)		
W1601MA-1PY-C3Z2	W1601MA-2Y-C3T2	50	93
W1601MA-3PY-C3Z2	W1601MA-4Y-C3T2	100	143
W1602MA-1PY-C3Z2	W1602MA-2Y-C3T2	150	193
W1602MA-3PY-C3Z2	W1602MA-4Y-C3T2	200	243
W1603MA-1PY-C3Z2	W1603MA-2Y-C3T2	300	343

- Notes: 1. We recommend NSK support unit. See page B389 for details.
 2. Use of NSK grease PS2 is recommended. Recommended quantity of grease is about 50% of ball nut's internal space. See page D16 for details.
 3. Contact NSK if the permissible rotational speed is to be exceeded.
 4. If Fixed is used for opposite driven side, configuration of support bearing area is designed by the customer.
 5. See B51 and B52 for ball screw supporting method (Fixed-Supported, Fixed-Fixed, etc.).

Screw shaft length			Lead accuracy			Shaft run-out **	Mass (kg)	Permissible rotational speed N (min ⁻¹)	
L_t	L_a	L_o	T	e_p	v_u			Supporting condition	
								Fixed - Simple support	Fixed - Fixed
139	154	221	0	0.010	0.008	0.020	0.41	3 000	3 000
189	204	271	0	0.010	0.008	0.020	0.48	3 000	3 000
239	254	321	0	0.012	0.008	0.030	0.55	3 000	3 000
289	304	371	0	0.012	0.008	0.030	0.62	3 000	3 000
389	404	471	0	0.013	0.010	0.035	0.77	3 000	3 000

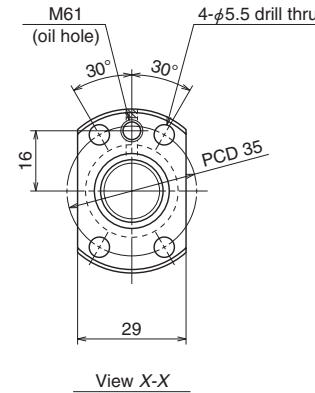
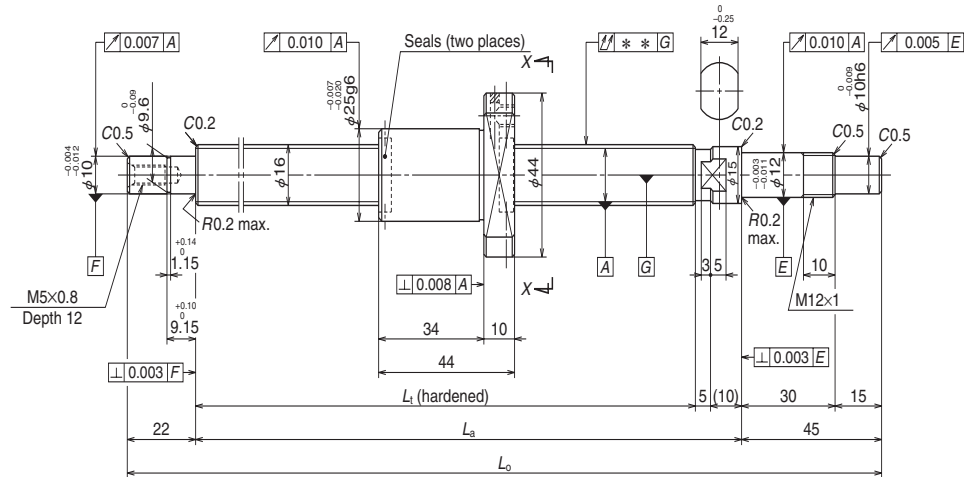

Ball screw specifications		
Product classification	Preloaded	Precise clearance
Shaft dia. x Lead / Direction of turn	16 x 2.5 / Right	
Preload / Ball recirculation	P-preload / Deflector (bridge)	
Ball dia. / Ball circle dia.	1.588 / 16.4	
Screw shaft root diameter	14.6	
Effective turns of balls	1 x 4	
Accuracy grade / Preload / Axial play	C3 / Z	C3 / T
Basic load rating (N)	Dynamic C _a	3 510
	Static C _{0a}	8 450
Axial play	0	0.005 or less
Preload (N)	147	—
Dynamic friction torque, (N·cm)	0.5 – 4.9	1.5 or less
Spacer ball	None	
Factory-packed grease	NSK grease PS2	
Internal spatial volume of nut (cm ³)	1.6	
Standard volume of grease replenishing (cm ³)	0.8	

Recommended support unit

For drive side (Fixed)	For opposite to drive side (Simple)
WBK12-01A (square)	WBK12S-01 (square)
WBK12-11 (round)	

Ball screw No.		Stroke	
		Nominal	Maximum
Preloaded (MPFD)	Precise clearance (MSFD)		
W1601MA-5PY-C3Z2.5	W1601MA-6Y-C3T2.5	50	89
W1601MA-7PY-C3Z2.5	W1601MA-8Y-C3T2.5	100	139
W1602MA-5PY-C3Z2.5	W1602MA-6Y-C3T2.5	150	189
W1602MA-7PY-C3Z2.5	W1602MA-8Y-C3T2.5	200	239
W1603MA-3PY-C3Z2.5	W1603MA-4Y-C3T2.5	300	339

- Notes:
1. We recommend NSK support unit. See page B389 for details.
 2. Use of NSK grease PS2 is recommended. Recommended quantity of grease is about 50% of ball nut's internal space. See page D16 for details.
 3. Contact NSK if permissible rotational speed is to be exceeded.
 4. If Fixed is used for opposite driven side, configuration of support bearing area is designed by the customer.
 5. See B51 and B52 for ball screw supporting method (Fixed-Supported, Fixed-Fixed, etc.).

Screw shaft length			Lead accuracy			Shaft run-out **	Mass (kg)	Permissible rotational speed N (min ⁻¹)	
L _t	L _a	L _o	T	e _p	v _u			Supporting condition	
								Fixed - Simple support	Fixed - Fixed
139	154	221	0	0.010	0.008	0.020	0.42	3 000	3 000
189	204	271	0	0.010	0.008	0.020	0.49	3 000	3 000
239	254	321	0	0.012	0.008	0.030	0.57	3 000	3 000
289	304	371	0	0.012	0.008	0.030	0.64	3 000	3 000
389	404	471	0	0.013	0.010	0.035	0.79	3 000	3 000

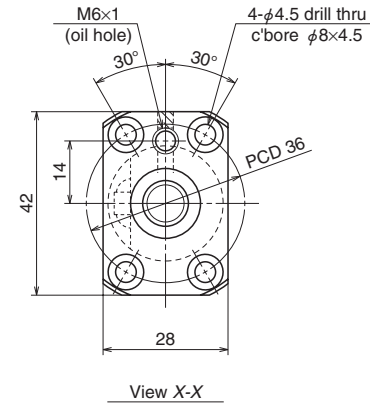
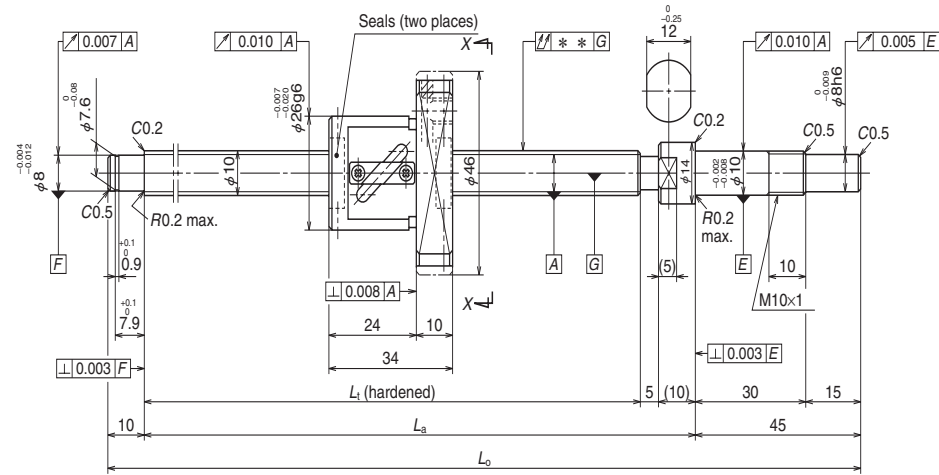

Ball screw specifications		
Product classification	Preloaded	Precise clearance
Shaft dia. x Lead / Direction of turn	10 x 4 / Right	
Preload / Ball recirculation	P-preload / Return tube	
Ball dia. / Ball circle dia.	2.000 / 10.3	
Screw shaft root diameter	8.2	
Effective turns of balls	2.5 x 1	
Accuracy grade / Preload / Axial play	C3 / Z	C3 / T
Basic load rating (N)	Dynamic C _a	1 730
	Static C _{0a}	2 230
Axial play	0	0.005 or less
Preload (N)	98.1	—
Dynamic friction torque, (N-cm)	0.5 - 3.9	1.0 or less
Spacer ball	Yes	None
Factory-packed grease	NSK grease PS2	
Internal spatial volume of nut (cm ³)	0.8	
Standard volume of grease replenishing (cm ³)	0.4	

Recommended support unit

For drive side (Fixed)	For opposite to drive side (Simple)
WBK10-01A (square)	WBK10S-01 (square)
WBK10-11 (round)	

Unit: mm

Ball screw No.		Stroke	
		Nominal	Maximum
Preloaded (PFT)	Precise clearance (SFT)		
W1001FA-1P-C3Z4	W1001FA-2-C3T4	50	69
W1001FA-3P-C3Z4	W1001FA-4-C3T4	100	119
W1002FA-1P-C3Z4	W1002FA-2-C3T4	150	169
W1002FA-3P-C3Z4	W1002FA-4-C3T4	200	219
W1003FA-1P-C3Z4	W1003FA-2-C3T4	250	269
W1003FA-3P-C3Z4	W1003FA-4-C3T4	300	319

Screw shaft length			Lead accuracy			Shaft run-out **	Mass (kg)	Permissible rotational speed N (min ⁻¹)
L _t	L _a	L _o	T	e _p	v _u			
110	125	180	0	0.010	0.008	0.020	0.26	3 000
160	175	230	0	0.010	0.008	0.030	0.28	3 000
210	225	280	0	0.012	0.008	0.030	0.31	3 000
260	275	330	0	0.012	0.008	0.040	0.34	3 000
310	325	380	0	0.012	0.008	0.040	0.37	3 000
360	375	430	0	0.013	0.010	0.050	0.39	3 000

- Notes: 1. We recommend NSK support unit. See page B389 for details.
 2. Use of NSK grease PS2 is recommended. Recommended quantity of grease is about 50% of ball nut's internal space. See page D16 for details.
 3. Contact NSK if permissible rotational speed is to be exceeded.

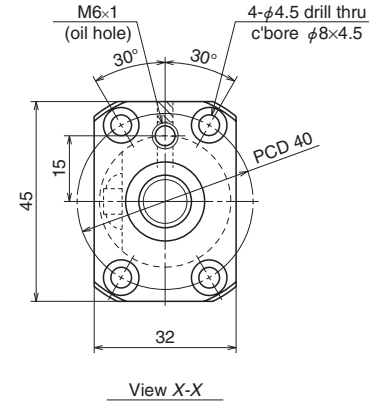
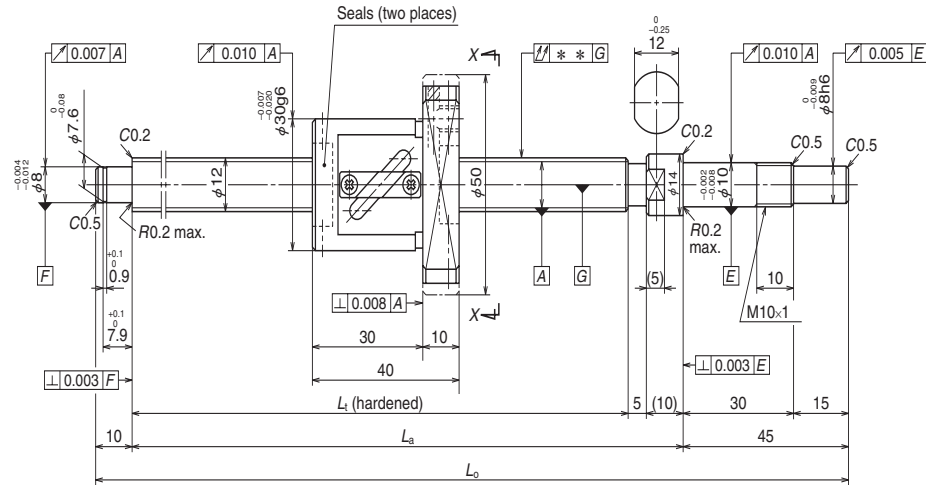

Ball screw specifications		
Product classification	Preloaded	Precise clearance
Shaft dia. x Lead / Direction of turn	12 x 5 / Right	
Preload / Ball recirculation	P-preload / Return tube	
Ball dia. / Ball circle dia.	2.381 / 12.3	
Screw shaft root diameter	9.8	
Effective turns of balls	2.5 x 1	
Accuracy grade / Preload / Axial play	C3 / Z	C3 / T
Basic load rating (N)	Dynamic C _a	2 370
	Static C _{0a}	3 160
Axial play	0	0.005 or less
Preload (N)	98.1	—
Dynamic friction torque, (N-cm)	1.0 - 4.4	1.0 or less
Spacer ball	Yes	None
Factory-packed grease	NSK grease PS2	
Internal spatial volume of nut (cm ³)	1.2	
Standard volume of grease replenishing (cm ³)	0.6	

Recommended support unit

For drive side (Fixed)	For opposite to drive side (Simple)
WBK10-01A (square)	WBK10S-01 (square)
WBK10-11 (round)	

Unit: mm

Ball screw No.		Stroke	
		Nominal	Maximum
Preloaded (PFT)	Precise clearance (SFT)		
W1201FA-1P-C3Z5	W1201FA-2-C3T5	50	63
W1201FA-3P-C3Z5	W1201FA-4-C3T5	100	113
W1202FA-1P-C3Z5	W1202FA-2-C3T5	150	163
W1202FA-3P-C3Z5	W1202FA-4-C3T5	200	213
W1203FA-1P-C3Z5	W1203FA-2-C3T5	250	263
W1204FA-1P-C3Z5	W1204FA-2-C3T5	350	363
W1205FA-1P-C3Z5	W1205FA-2-C3T5	450	463

Screw shaft length			Lead accuracy			Shaft run-out **	Mass (kg)	Permissible rotational speed N (min ⁻¹)	
								Supporting condition	
L _t	L _a	L _o	T	e _p	v _u	↕	Fixed - Simple support		
110	125	180	0	0.010	0.008			0.020	0.35
160	175	230	0	0.010	0.008	0.030	0.38	3 000	
210	225	280	0	0.012	0.008	0.030	0.42	3 000	
260	275	330	0	0.012	0.008	0.040	0.46	3 000	
310	325	380	0	0.012	0.008	0.040	0.50	3 000	
410	425	480	0	0.015	0.010	0.050	0.58	3 000	
510	525	580	0	0.016	0.012	0.065	0.66	3 000	

- Notes: 1. We recommend NSK support unit. See page B389 for details.
 2. Use of NSK grease PS2 is recommended. Recommended quantity of grease is about 50% of ball nut's internal space. See page D16 for details.
 3. Contact NSK if permissible rotational speed is to be exceeded.

Finished shaft end FA Type

(Medium lead)

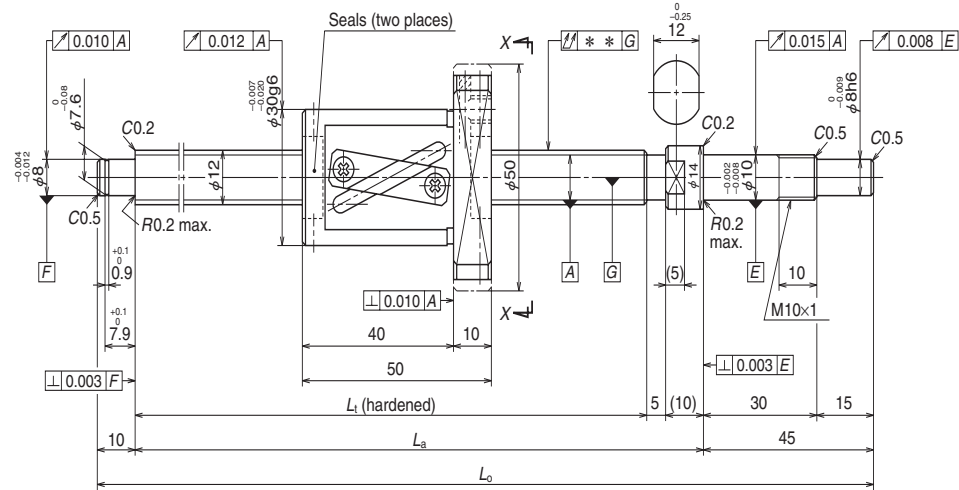

Nut models: LPFT, LSFT

NSK

Screw shaft ø12

Lead 10

Unit: mm

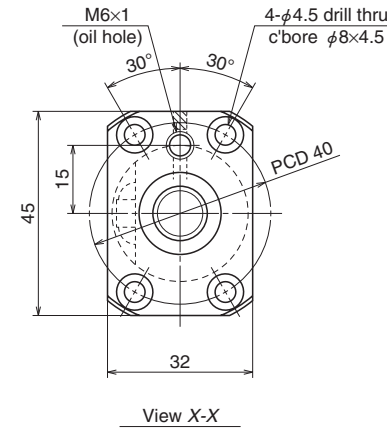

Ball screw specifications			
Product classification	Preloaded	Precise clearance	
Shaft dia. x Lead / Direction of turn	12 x 10 / Right		
Preload / Ball recirculation	P-preload / Return tube		
Ball dia. / Ball circle dia.	2.381 / 12.5		
Screw shaft root diameter	10.0		
Effective turns of balls	2.5 x 1		
Accuracy grade / Preload / Axial play	C5 / Z	C5 / T	
Basic load rating (N)	Dynamic C_d	2 360	3 750
	Static C_0	3 240	6 480
Axial play	0	0.005 or less	
Preload (N)	98.1	—	
Dynamic friction torque, (N-cm)	1.0 - 4.9	1.5 or less	
Spacer ball	Yes	None	
Factory-packed grease	NSK grease LR3		
Internal spatial volume of nut (cm ³)	1.4		
Standard volume of grease replenishing (cm ³)	0.7		

Recommended support unit

For drive side (Fixed)	For opposite to drive side (Simple)
WBK10-01A (square)	WBK10S-01 (square)
WBK10-11 (round)	

Unit: mm

Ball screw No.		Stroke	
		Nominal	Maximum
Preloaded (LPFT)	Precise clearance (LSFT)		
W1201FA-5P-C5Z10	W1201FA-6-C5T10	100	103
W1202FA-5P-C5Z10	W1202FA-6-C5T10	150	153
W1203FA-3P-C5Z10	W1203FA-4-C5T10	250	253
W1204FA-3P-C5Z10	W1204FA-4-C5T10	350	353
W1205FA-3P-C5Z10	W1205FA-4-C5T10	450	453

Screw shaft length			Lead accuracy			Shaft run-out **	Mass (kg)	Permissible rotational speed N (min ⁻¹)	
								Supporting condition	
L_t	L_a	L_o	T	e_p	v_u	Fixed - Simple support			
160	175	230	0	0.020	0.018		0.035	0.43	3 000
210	225	280	0	0.023	0.018	0.035	0.47	3 000	
310	325	380	0	0.023	0.018	0.050	0.56	3 000	
410	425	480	0	0.027	0.020	0.060	0.64	3 000	
510	525	580	0	0.030	0.023	0.075	0.72	3 000	

- Notes: 1. We recommend NSK support unit. See page B389 for details.
 2. Use of NSK grease LR3 is recommended. Recommended quantity of grease is about 50% of ball nut's internal space. See page D16 for details.
 3. Contact NSK if the permissible rotational speed is to be exceeded.

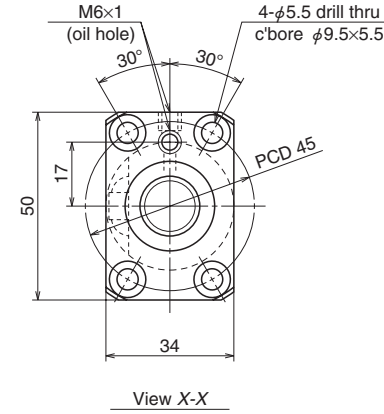
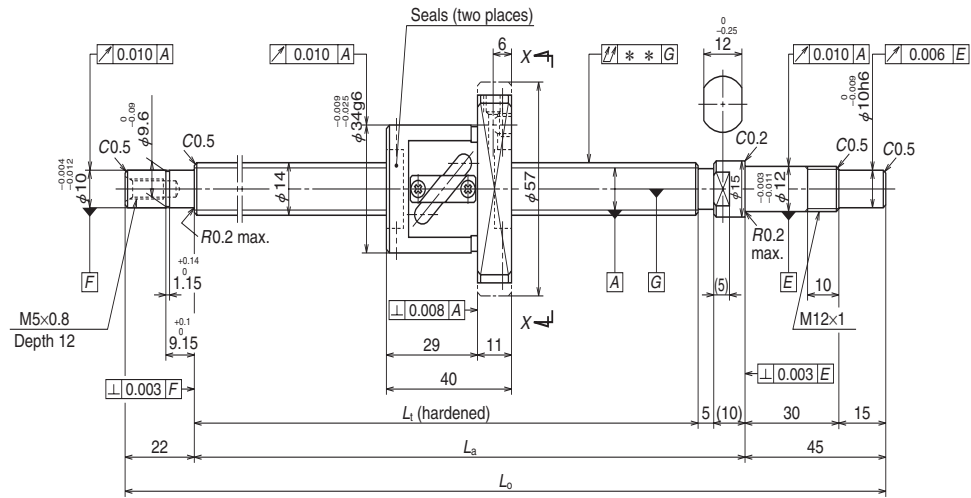

Ball screw specifications			
Product classification	Preloaded	Precise clearance	
Shaft dia. x Lead / Direction of turn	14 x 5 / Right		
Preload / Ball recirculation	P-preload / Return tube		
Ball dia. / Ball circle dia.	3.175 / 14.5		
Screw shaft root diameter	11.2		
Effective turns of balls	2.5 x 1		
Accuracy grade / Preload / Axial play	C3 / Z	C3 / T	
Basic load rating (N)	Dynamic C_a	4 280	6 790
	Static C_{0a}	5 840	11 700
Axial play	0	0.005 or less	
Preload (N)	147	—	
Dynamic friction torque, (N-cm)	1.5 - 6.9	2.0 or less	
Spacer ball	Yes	None	
Factory-packed grease	NSK grease LR3		
Internal spatial volume of nut (cm ³)	2.2		
Standard volume of grease replenishing (cm ³)	1.1		

Recommended support unit

For drive side (Fixed)	For opposite to drive side (Simple)
WBK12-01A (square)	WBK12S-01 (square)
WBK12-11 (round)	

Unit: mm

Ball screw No.		Stroke	
		Nominal	Maximum
Preloaded (PFT)	Precise clearance (SFT)		
W1401FA-1P-C3Z5	W1401FA-2-C3T5	100	143
W1402FA-1P-C3Z5	W1402FA-2-C3T5	150	193
W1403FA-1P-C3Z5	W1403FA-2-C3T5	250	293
W1404FA-1P-C3Z5	W1404FA-2-C3T5	350	393
W1405FA-1P-C3Z5	W1405FA-2-C3T5	450	493
W1406FA-1P-C3Z5	W1406FA-2-C3T5	600	643

- Notes:
1. We recommend NSK support unit. See page B389 for details.
 2. Use of NSK grease LR3 is recommended. Recommended quantity of grease is about 50% of ball nut's internal space. See page D16 for details.
 3. Contact NSK if the permissible rotational speed is to be exceeded.

Screw shaft length			Lead accuracy			Shaft run-out **	Mass (kg)	Permissible rotational speed N (min ⁻¹)	
								Supporting condition	
L_t	L_a	L_o	T	e_p	v_a		Fixed - Simple support	Fixed - Fixed	
189	204	271	0	0.010	0.008	0.020	0.52	3 000	3 000
239	254	321	0	0.012	0.008	0.030	0.57	3 000	3 000
339	354	421	0	0.013	0.010	0.035	0.67	3 000	3 000
439	454	521	0	0.015	0.010	0.045	0.77	3 000	3 000
539	554	621	0	0.016	0.012	0.045	0.87	3 000	3 000
689	704	771	0	0.018	0.013	0.055	1.0	3 000	3 000

- Notes:
4. If Fixed is used for opposite driven side, configuration of support bearing area is designed by the customer.
 5. See B51 and B52 for ball screw supporting method (Fixed-Supported, Fixed-Fixed, etc.).

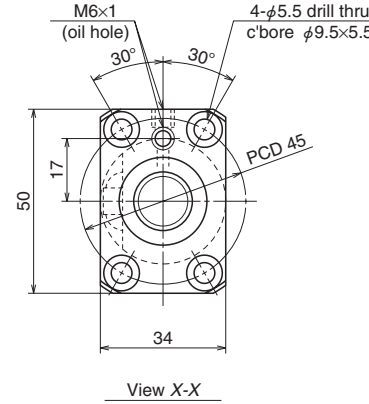
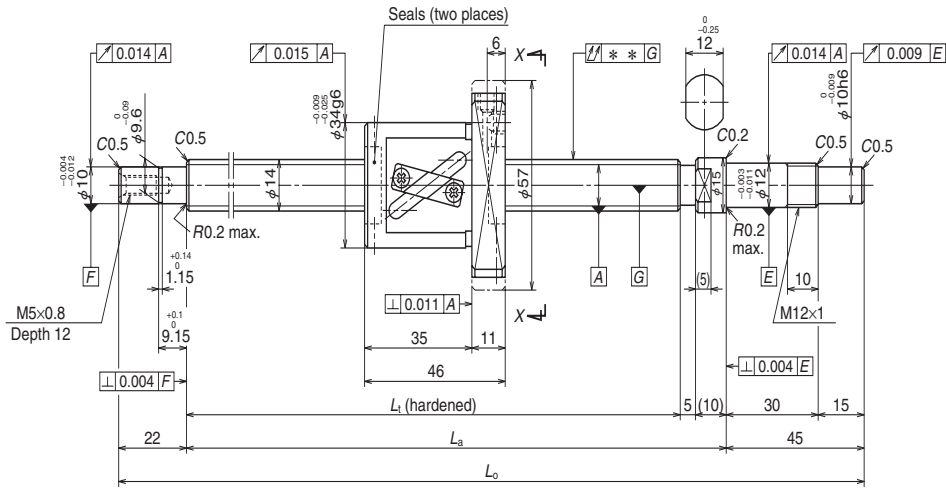

Ball screw specifications		
Product classification	Preloaded	Precise clearance
Shaft dia. x Lead / Direction of turn	14 × 8 / Right	
Preload / Ball recirculation	P-preload / Return tube	
Ball dia. / Ball circle dia.	3.175 / 14.5	
Screw shaft root diameter	11.2	
Effective turns of balls	2.5 × 1	
Accuracy grade / Preload / Axial play	C5 / Z	C5 / T
Basic load rating (N)	Dynamic C _a	4 280
	Static C _{0a}	5 840
Axial play		0
Preload (N)		147
Dynamic friction torque, (N·cm)		1.5 - 7.8
Spacer ball		Yes
Factory-packed grease		NSK grease LR3
Internal spatial volume of nut (cm ³)		2.1
Standard volume of grease replenishing (cm ³)		1.1

Recommended support unit

For drive side (Fixed)	For opposite to drive side (Simple)
WBK12-01A (square)	WBK12S-01 (square)
WBK12-11 (round)	

Unit: mm

Ball screw No.		Stroke	
		Nominal	Maximum
Preloaded (LPFT)	Precise clearance (LSFT)		
W1401FA-3P-C5Z8	W1401FA-4-C5T8	100	137
W1402FA-3P-C5Z8	W1402FA-4-C5T8	150	187
W1402FA-5P-C5Z8	W1402FA-6-C5T8	200	237
W1403FA-3P-C5Z8	W1403FA-4-C5T8	250	287
W1403FA-5P-C5Z8	W1403FA-6-C5T8	300	337
W1404FA-3P-C5Z8	W1404FA-4-C5T8	350	387
W1404FA-5P-C5Z8	W1404FA-6-C5T8	400	437
W1405FA-3P-C5Z8	W1405FA-4-C5T8	450	487
W1405FA-5P-C5Z8	W1405FA-6-C5T8	500	537
W1406FA-3P-C5Z8	W1406FA-4-C5T8	550	587
W1406FA-5P-C5Z8	W1406FA-6-C5T8	600	637
W1407FA-1P-C5Z8	W1407FA-2-C5T8	700	737

- Notes: 1. We recommend NSK support unit. See page B389 for details.
 2. Use of NSK grease LR3 is recommended. Recommended quantity of grease is about 50% of ball nut's internal space. See page D16 for details.
 3. Contact NSK if the permissible rotational speed is to be exceeded.

Screw shaft length			Lead accuracy			Shaft run-out **	Mass (kg)	Permissible rotational speed N (min ⁻¹)	
								Supporting condition	
L _t	L _a	L _o	T	e _p	v _a		Fixed - Simple support	Fixed - Fixed	
189	204	271	0	0.020	0.018	0.025	0.56	3 000	3 000
239	254	321	0	0.023	0.018	0.035	0.61	3 000	3 000
289	304	371	0	0.023	0.018	0.035	0.67	3 000	3 000
339	354	421	0	0.025	0.020	0.040	0.72	3 000	3 000
389	404	471	0	0.025	0.020	0.040	0.78	3 000	3 000
439	454	521	0	0.027	0.020	0.050	0.83	3 000	3 000
489	504	571	0	0.027	0.020	0.050	0.88	3 000	3 000
539	554	621	0	0.030	0.023	0.050	0.94	3 000	3 000
589	604	671	0	0.030	0.023	0.065	0.99	3 000	3 000
639	654	721	0	0.035	0.025	0.065	1.0	3 000	3 000
689	704	771	0	0.035	0.025	0.065	1.1	3 000	3 000
789	804	871	0	0.035	0.025	0.085	1.2	2 830	3 000

- Notes: 4. If Fixed is used for opposite driven side, configuration of support bearing area is designed by the customer.
 5. See B51 and B52 for ball screw supporting method (Fixed-Supported, Fixed-Fixed, etc.).

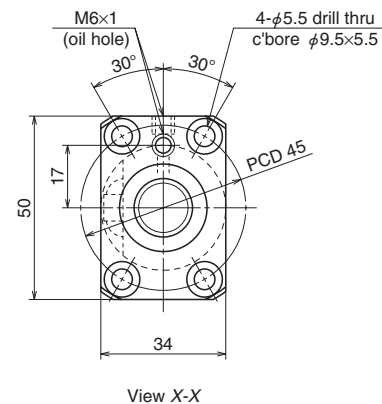
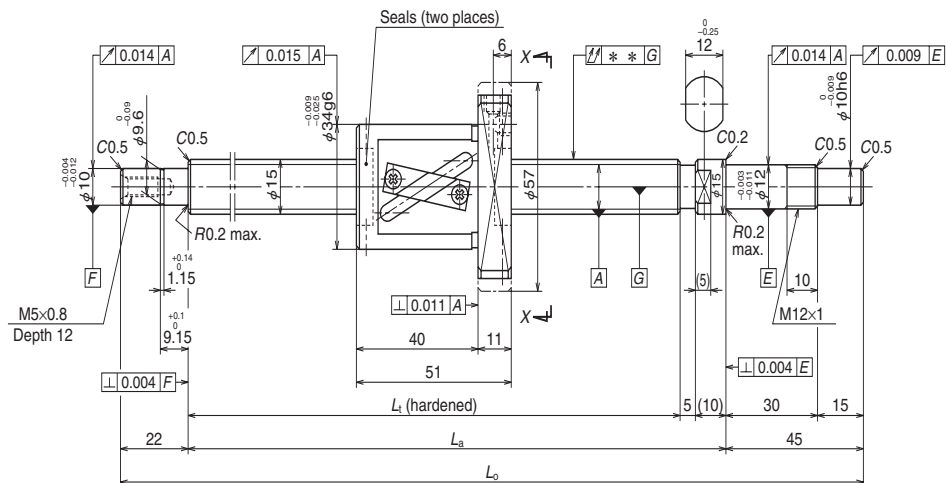

Recommended support unit

For drive side (Fixed)	For opposite to drive side (Simple)
WBK12-01A (square)	WBK12S-01 (square)
WBK12-11 (round)	

Ball screw specifications		
Product classification	Preloaded	Precise clearance
Shaft dia. x Lead / Direction of turn	15 × 10 / Right	
Preload / Ball recirculation	P-preload / Return tube	
Ball dia. / Ball circle dia.	3.175 / 15.5	
Screw shaft root diameter	12.2	
Effective turns of balls	2.5 × 1	
Accuracy grade / Preload / Axial play	C5 / Z	C5 / T
Basic load rating (N)	Dynamic C_a	4 450
	Static C_{0a}	6 380
7 070	12 800	
Axial play	0	0.005 or less
Preload (N)	147	—
Dynamic friction torque, (N·cm)	1.5 – 7.8	2.4 or less
Spacer ball	Yes	None
Factory-packed grease	NSK grease LR3	
Internal spatial volume of nut (cm ³)	2.3	
Standard volume of grease replenishing (cm ³)	1.2	

Unit: mm

Ball screw No.		Stroke	
		Nominal	Maximum
Preloaded (LPFT)	Precise clearance (LSFT)		
W1501FA-1P-C5Z10	W1501FA-2-C5T10	100	132
W1502FA-1P-C5Z10	W1502FA-2-C5T10	150	182
W1502FA-3P-C5Z10	W1502FA-4-C5T10	200	232
W1503FA-1P-C5Z10	W1503FA-2-C5T10	250	282
W1503FA-3P-C5Z10	W1503FA-4-C5T10	300	332
W1504FA-1P-C5Z10	W1504FA-2-C5T10	350	382
W1504FA-3P-C5Z10	W1504FA-4-C5T10	400	432
W1505FA-1P-C5Z10	W1505FA-2-C5T10	450	482
W1505FA-3P-C5Z10	W1505FA-4-C5T10	500	532
W1506FA-1P-C5Z10	W1506FA-2-C5T10	550	582
W1506FA-3P-C5Z10	W1506FA-4-C5T10	600	632
W1507FA-1P-C5Z10	W1507FA-2-C5T10	700	732
W1508FA-1P-C5Z10	W1508FA-2-C5T10	800	832
W1510FA-1P-C5Z10	W1510FA-2-C5T10	1 000	1 032

- Notes: 1. We recommend NSK support unit. See page B389 for details.
 2. Use of NSK grease LR3 is recommended. Recommended quantity of grease is about 50% of ball nut's internal space. See page D16 for details.
 3. Contact NSK if the permissible rotational speed is to be exceeded.

Screw shaft length			Lead accuracy			Shaft run-out **	Mass (kg)	Permissible rotational speed N (min ⁻¹)	
								Supporting condition	
L_t	L_a	L_o	T	e_p	v_u			Fixed - Simple support	Fixed - Fixed
189	204	271	0	0.020	0.018	0.025	0.61	3 000	3 000
239	254	321	0	0.023	0.018	0.035	0.67	3 000	3 000
289	304	371	0	0.023	0.018	0.035	0.74	3 000	3 000
339	354	421	0	0.025	0.020	0.040	0.80	3 000	3 000
389	404	471	0	0.025	0.020	0.040	0.86	3 000	3 000
439	454	521	0	0.027	0.020	0.050	0.93	3 000	3 000
489	504	571	0	0.027	0.020	0.050	1.0	3 000	3 000
539	554	621	0	0.030	0.023	0.050	1.1	3 000	3 000
589	604	671	0	0.030	0.023	0.065	1.1	3 000	3 000
639	654	721	0	0.035	0.025	0.065	1.2	3 000	3 000
689	704	771	0	0.035	0.025	0.065	1.2	3 000	3 000
789	804	871	0	0.035	0.025	0.085	1.4	3 000	3 000
889	904	971	0	0.040	0.027	0.085	1.5	2 430	3 000
1 089	1 104	1 171	0	0.046	0.030	0.110	1.8	1 600	2 250

- Notes: 4. If Fixed is used for opposite driven side, configuration of support bearing area is designed by the customer.
 5. See B51 and B52 for ball screw supporting method (Fixed-Supported, Fixed-Fixed, etc.).

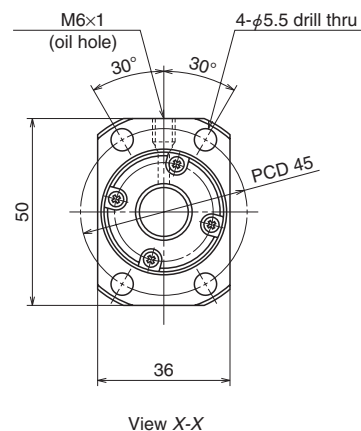
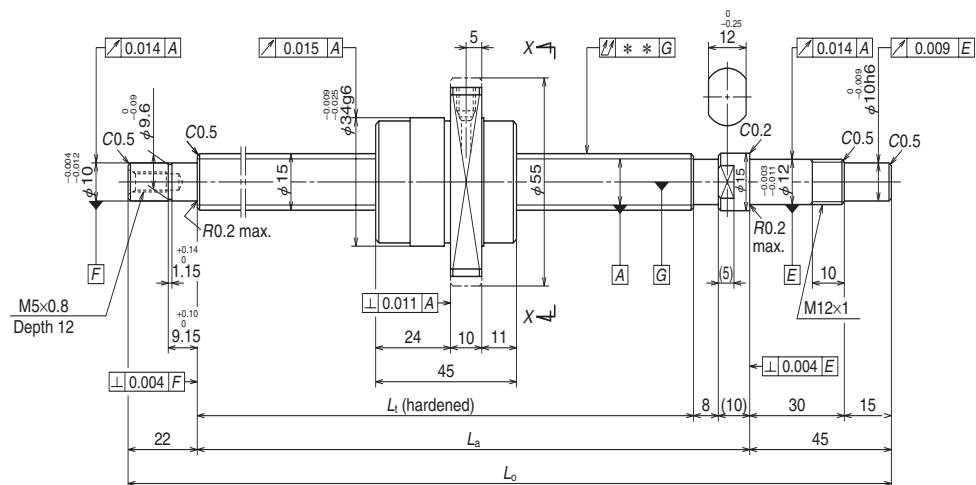

Recommended support unit

For drive side (Fixed)	For opposite to drive side (Simple)
WBK12-01A (square)	WBK12S-01 (square)
WBK12-11 (round)	

Ball screw specifications		
Product classification	Preloaded	Precise clearance
Shaft dia. x Lead / Direction of turn	15 × 20 / Right	
Preload / Ball recirculation	P-preload / End cap	
Ball dia. / Ball circle dia.	3.175 / 15.5	
Screw shaft root diameter	12.2	
Effective turns of balls	1.7 × 1	
Accuracy grade / Preload / Axial play	C5 / Z	C5 / T
Basic load rating (N)	Dynamic C _a	3 870
	Static C _{0a}	5 820
Dynamic C _{0a}	5 820	8 730
Axial play	0	0.005 or less
Preload (N)	147	—
Dynamic friction torque, (N·cm)	1.5 – 7.8	2.4 or less
Spacer ball	Yes	None
Factory-packed grease	NSK grease LR3	
Internal spatial volume of nut (cm ³)	1.9	
Standard volume of grease replenishing (cm ³)	1.0	

Unit: mm

Ball screw No.		Stroke	
		Nominal	Maximum
Preloaded (UPFC)	Precise clearance (USFC)		
W1501FA-3PG-C5Z20	W1501FA-4G-C5T20	100	135
W1502FA-5PG-C5Z20	W1502FA-6G-C5T20	150	185
W1502FA-7PG-C5Z20	W1502FA-8G-C5T20	200	235
W1503FA-5PG-C5Z20	W1503FA-6G-C5T20	250	285
W1503FA-7PG-C5Z20	W1503FA-8G-C5T20	300	335
W1504FA-5PG-C5Z20	W1504FA-6G-C5T20	350	385
W1504FA-7PG-C5Z20	W1504FA-8G-C5T20	400	435
W1505FA-5PG-C5Z20	W1505FA-6G-C5T20	450	485
W1505FA-7PG-C5Z20	W1505FA-8G-C5T20	500	535
W1506FA-5PG-C5Z20	W1506FA-6G-C5T20	550	585
W1506FA-7PG-C5Z20	W1506FA-8G-C5T20	600	635
W1507FA-3PG-C5Z20	W1507FA-4G-C5T20	700	735
W1508FA-3PG-C5Z20	W1508FA-4G-C5T20	800	835
W1510FA-3PG-C5Z20	W1510FA-4G-C5T20	1 000	1 035

- Notes: 1. We recommend NSK support unit. See page B389 for details.
 2. Use of NSK grease LR3 is recommended. Recommended quantity of grease is about 50% of ball nut's internal space. See page D16 for details.
 3. Contact NSK if the permissible rotational speed is to be exceeded.

Screw shaft length			Lead accuracy			Shaft run-out **	Mass (kg)	Permissible rotational speed N (min ⁻¹)	
								Supporting condition	
L _t	L _a	L _o	T	e _p	v _a		Fixed - Simple support	Fixed - Fixed	
186	204	271	0	0.020	0.018	0.025	0.61	3 000	3 000
236	254	321	0	0.023	0.018	0.035	0.68	3 000	3 000
286	304	371	0	0.023	0.018	0.035	0.75	3 000	3 000
336	354	421	0	0.025	0.020	0.040	0.81	3 000	3 000
386	404	471	0	0.025	0.020	0.040	0.88	3 000	3 000
436	454	521	0	0.027	0.020	0.050	0.95	3 000	3 000
486	504	571	0	0.027	0.020	0.050	1.0	3 000	3 000
536	554	621	0	0.030	0.023	0.050	1.1	3 000	3 000
586	604	671	0	0.030	0.023	0.065	1.1	3 000	3 000
636	654	721	0	0.035	0.025	0.065	1.2	3 000	3 000
686	704	771	0	0.035	0.025	0.065	1.3	3 000	3 000
786	804	871	0	0.035	0.025	0.085	1.4	3 000	3 000
886	904	971	0	0.040	0.027	0.085	1.5	2 440	3 000
1 086	1 104	1 171	0	0.046	0.030	0.110	1.8	1 610	2 240

- Notes: 4. If Fixed is used for opposite driven side, configuration of support bearing area is designed by the customer.
 5. See B51 and B52 for ball screw supporting method (Fixed-Supported, Fixed-Fixed, etc.).

Finished shaft end FA Type

(Fine lead)

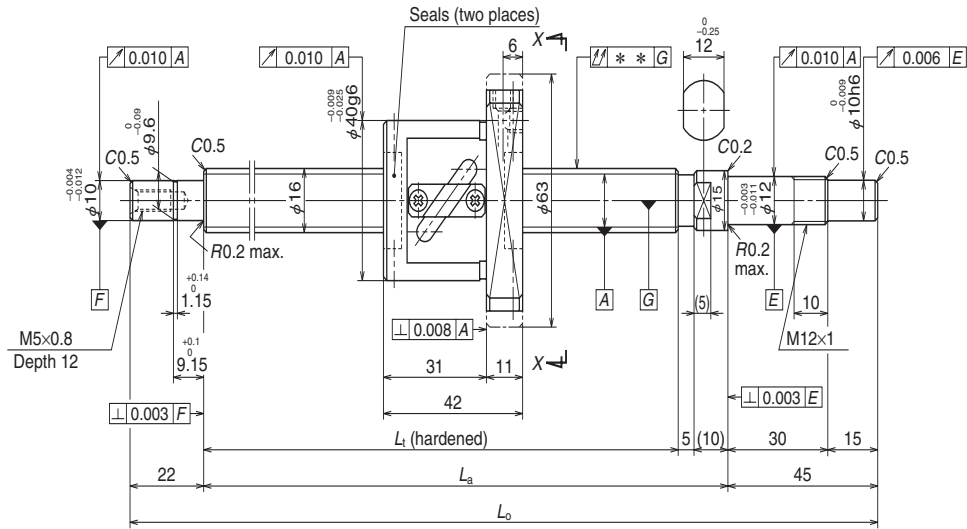

Nut models: PFT, SFT

NSK

Screw shaft ø16

Lead 5

Unit: mm

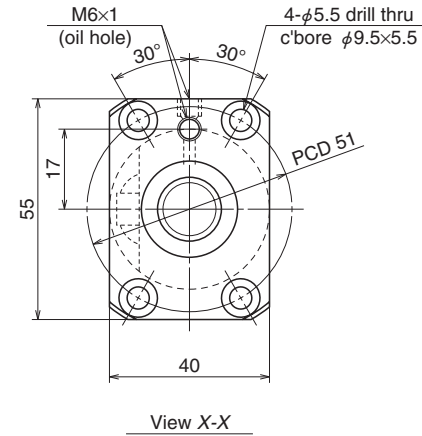

Ball screw specifications

Product classification		Preloaded	Precise clearance
Shaft dia. x Lead / Direction of turn		16 × 5 / Right	
Preload / Ball recirculation		P-preload / Return tube	
Ball dia. / Ball circle dia.		3.175 / 16.5	
Screw shaft root diameter		13.2	
Effective turns of balls		2.5 × 1	
Accuracy grade / Preload / Axial play		C3 / Z	C3 / T
Basic load rating (N)	Dynamic C_d	4 620	7 330
	Static C_0	6 750	13 500
Axial play		0	0.005 or less
Preload (N)		147	—
Dynamic friction torque, (N-cm)		1.5 – 7.8	2.0 or less
Spacer ball		Yes	None
Factory-packed grease		NSK grease LR3	
Internal spatial volume of nut (cm ³)		2.6	
Standard volume of grease replenishing (cm ³)		1.3	

Recommended support unit

For drive side (Fixed)	For opposite to drive side (Simple)
WBK12-01A (square)	WBK12S-01 (square)
WBK12-11 (round)	

Unit: mm

Ball screw No.		Stroke	
		Nominal	Maximum
Preloaded (PFT)	Precise clearance (SFT)		
W1601FA-1P-C3Z5	W1601FA-2-C3T5	100	141
W1602FA-1P-C3Z5	W1602FA-2-C3T5	200	241
W1603FA-1P-C3Z5	W1603FA-2-C3T5	300	341
W1604FA-1P-C3Z5	W1604FA-2-C3T5	400	441
W1606FA-1P-C3Z5	W1606FA-2-C3T5	600	641
W1608FA-1P-C3Z5	W1608FA-2-C3T5	800	841

- Notes:
1. We recommend NSK support unit. See page B389 for details.
 2. Use of NSK grease LR3 is recommended. Recommended quantity of grease is about 50% of ball nut's internal space. See page D16 for details.
 3. Contact NSK if the permissible rotational speed is to be exceeded.

Screw shaft length			Lead accuracy			Shaft run-out **	Mass (kg)	Permissible rotational speed N (min ⁻¹)	
L_t	L_a	L_o	T	e_p	v_a			Supporting condition	
								Fixed - Simple support	Fixed - Fixed
189	204	271	0	0.010	0.008	0.020	0.70	3 000	3 000
289	304	371	0	0.012	0.008	0.030	0.83	3 000	3 000
389	404	471	0	0.013	0.010	0.035	0.97	3 000	3 000
489	504	571	0	0.015	0.010	0.045	1.1	3 000	3 000
689	704	771	0	0.018	0.013	0.055	1.4	3 000	3 000
889	904	971	0	0.021	0.015	0.075	1.6	2 570	3 000

- Notes:
4. If Fixed is used for opposite driven side, configuration of support bearing area is designed by the customer.
 5. See B51 and B52 for ball screw supporting method (Fixed-Supported, Fixed-Fixed, etc.).

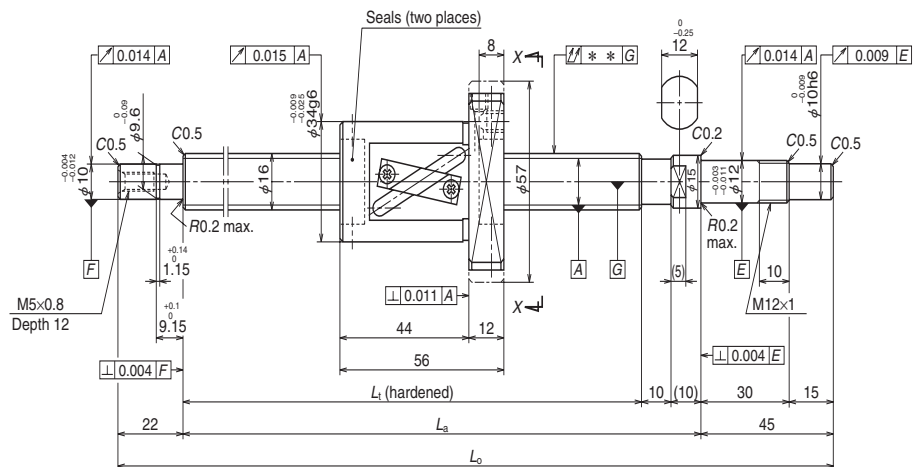

Screw shaft ø16

Lead 16

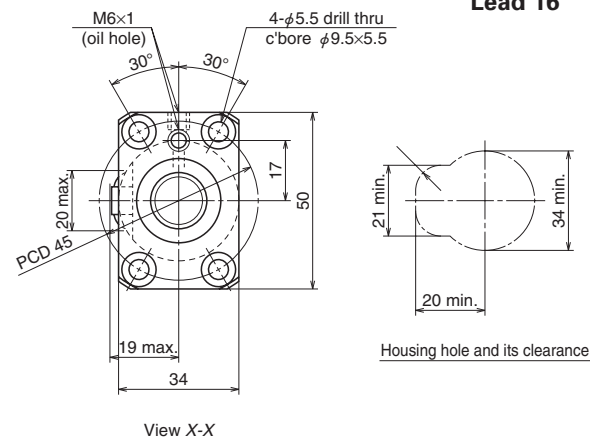

Recommended support unit

For drive side (Fixed)	For opposite to drive side (Simple)
WBK12-01A (square)	WBK12S-01 (square)
WBK12-11 (round)	

Ball screw specifications		
Product classification	Preloaded	Precise clearance
Shaft dia. x Lead / Direction of turn	16 x 16 / Right	
Preload / Ball recirculation	P-preload / Return tube	
Ball dia. / Ball circle dia.	3.175 / 16.75	
Screw shaft root diameter	13.4	
Effective turns of balls	1.5 x 1	
Accuracy grade / Preload / Axial play	C5 / Z	C5 / T
Basic load rating (N)	Dynamic C _a	3 600
	Static C _{0a}	5 410
Axial play	0	0.005 or less
Preload (N)	147	—
Dynamic friction torque, (N·cm)	1.5 - 7.8	2.4 or less
Spacer ball	Yes	None
Factory-packed grease	NSK grease LR3	
Internal spatial volume of nut (cm ³)	2.1	
Standard volume of grease replenishing (cm ³)	1.1	

Ball screw No.		Stroke	
Preloaded (LPFT)	Precise clearance (LSFT)	Nominal	Maximum
W1601FA-3P-C5Z16	W1601FA-4-C5T16	100	122
W1602FA-3P-C5Z16	W1602FA-4-C5T16	150	172
W1602FA-5P-C5Z16	W1602FA-6-C5T16	200	222
W1603FA-3P-C5Z16	W1603FA-4-C5T16	250	272
W1603FA-5P-C5Z16	W1603FA-6-C5T16	300	322
W1604FA-3P-C5Z16	W1604FA-4-C5T16	350	372
W1604FA-5P-C5Z16	W1604FA-6-C5T16	400	422
W1605FA-1P-C5Z16	W1605FA-2-C5T16	450	472
W1605FA-3P-C5Z16	W1605FA-4-C5T16	500	522
W1606FA-3P-C5Z16	W1606FA-4-C5T16	550	572
W1606FA-5P-C5Z16	W1606FA-6-C5T16	600	622
W1607FA-1P-C5Z16	W1607FA-2-C5T16	700	722
W1608FA-3P-C5Z16	W1608FA-4-C5T16	800	822
W1610FA-1P-C5Z16	W1610FA-2-C5T16	1 000	1 022

- Notes: 1. We recommend NSK support unit. See page B389 for details.
- 2. Use of NSK grease LR3 is recommended. Recommended quantity of grease is about 50% of ball nut's internal space. See page D16 for details.
- 3. Contact NSK if permissible rotational speed is to be exceeded.

Screw shaft length			Lead accuracy			Shaft run-out **	Mass (kg)	Permissible rotational speed N (min ⁻¹)	
L _t	L _a	L _o	T	e _p	v _a			Supporting condition	
								Fixed - Simple support	Fixed - Fixed
184	204	271	0	0.020	0.018	0.025	0.69	3 000	3 000
234	254	321	0	0.023	0.018	0.035	0.77	3 000	3 000
284	304	371	0	0.023	0.018	0.035	0.84	3 000	3 000
334	354	421	0	0.025	0.020	0.040	0.92	3 000	3 000
384	404	471	0	0.025	0.020	0.040	0.99	3 000	3 000
434	454	521	0	0.027	0.020	0.050	1.1	3 000	3 000
484	504	571	0	0.027	0.020	0.050	1.1	3 000	3 000
534	554	621	0	0.030	0.023	0.050	1.2	3 000	3 000
584	604	671	0	0.030	0.023	0.065	1.3	3 000	3 000
634	654	721	0	0.035	0.025	0.065	1.4	3 000	3 000
684	704	771	0	0.035	0.025	0.065	1.4	3 000	3 000
784	804	871	0	0.035	0.025	0.085	1.6	3 000	3 000
884	904	971	0	0.040	0.027	0.085	1.7	2 720	3 000
1 084	1 104	1 171	0	0.046	0.030	0.110	2.0	1 790	2 480

- Notes: 4. If Fixed is used for opposite driven side, configuration of support bearing area is designed by the customer.
- 5. See B51 and B52 for ball screw supporting method (Fixed-Supported, Fixed-Fixed, etc.).

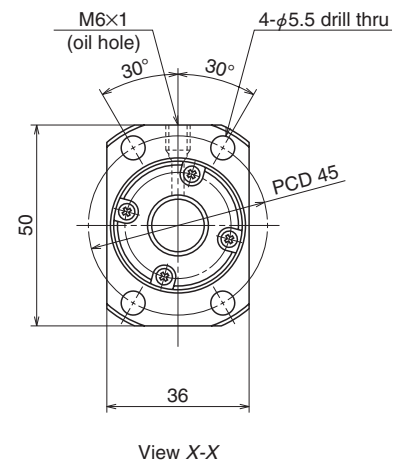
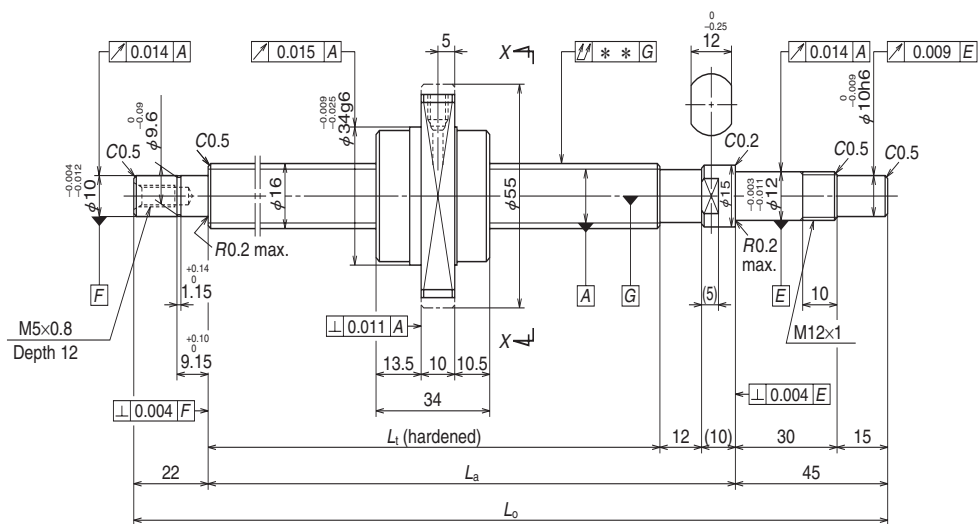

Ball screw specifications		
Product classification	Preloaded	Precise clearance
Shaft dia. x Lead / Direction of turn	16 x 32 / Right	
Preload / Ball recirculation	P-preload / End cap	
Ball dia. / Ball circle dia.	3.175 / 16.75	
Screw shaft root diameter	13.4	
Effective turns of balls	0.7 x 2	
Accuracy grade / Preload / Axial play	C5 / Z	C5 / T
Basic load rating (N)	Dynamic C_d	4 000
	Static C_0	6 690
Axial play	0	0.005 or less
Preload (N)	118	—
Dynamic friction torque, (N-cm)	1.5 - 9.8	2.4 or less
Spacer ball	None	
Factory-packed grease	NSK grease LR3	
Internal spatial volume of nut (cm ³)	2.0	
Standard volume of grease replenishing (cm ³)	1.0	

Recommended support unit

For drive side (Fixed)	For opposite to drive side (Simple)
WBK12-01A (square)	WBK12S-01 (square)
WBK12-11 (round)	

Ball screw No.		Stroke	
		Nominal	Maximum
Preloaded (UPFC)	Precise clearance (USFC)		
W1603FA-7PGX-C5Z32	W1603FA-8GX-C5T32	300	342
W1605FA-5PGX-C5Z32	W1605FA-6GX-C5T32	500	542
W1608FA-5PGX-C5Z32	W1608FA-6GX-C5T32	800	842
W1612FA-1PGX-C5Z32	W1612FA-2GX-C5T32	1 200	1 242

Screw shaft length			Lead accuracy			Shaft run-out **	Mass (kg)	Permissible rotational speed N (min ⁻¹)	
L_t	L_a	L_o	T	e_p	v_a			Supporting condition	
								Fixed - Simple support	Fixed - Fixed
382	404	471	0	0.025	0.020	0.040	0.90	3 000	3 000
582	604	671	0	0.030	0.023	0.065	1.2	3 000	3 000
882	904	971	0	0.040	0.027	0.085	1.7	2 670	3 000
1 282	1 304	1 371	0	0.054	0.035	0.150	2.3	1 250	1 740

- Notes:
1. We recommend NSK support unit. See page B389 for details.
 2. Use of NSK grease LR3 is recommended. Recommended quantity of grease is about 50% of ball nut's internal space. See page D16 for details.
 3. Ball nut does not have seal.
 4. Contact NSK if the permissible rotational speed is to be exceeded.

- Notes:
5. If Fixed is used for opposite driven side, configuration of support bearing area is designed by the customer.
 6. See B51 and B52 for ball screw supporting method (Fixed-Supported, Fixed-Fixed, etc.).

Finished shaft end FA Type

(Medium lead)

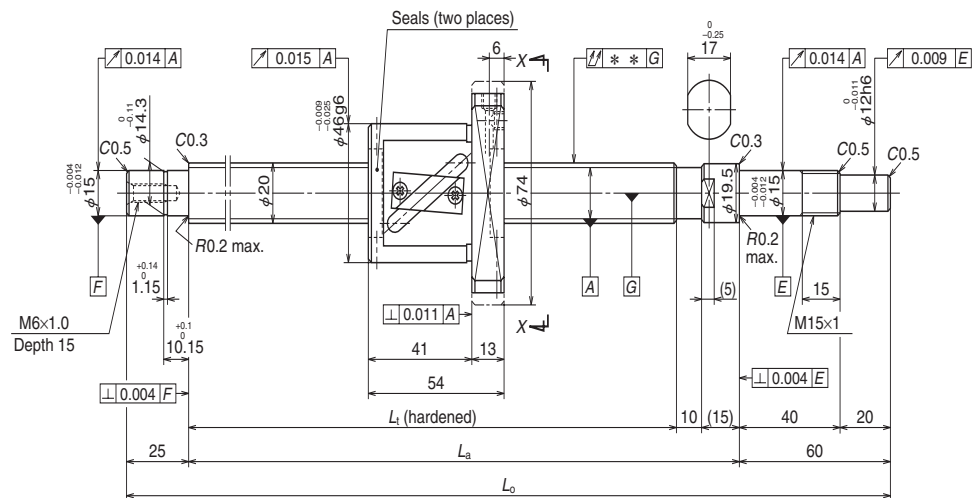

Nut models: LPFT, LSFT

NSK

Screw shaft ø20

Lead 10

Unit: mm

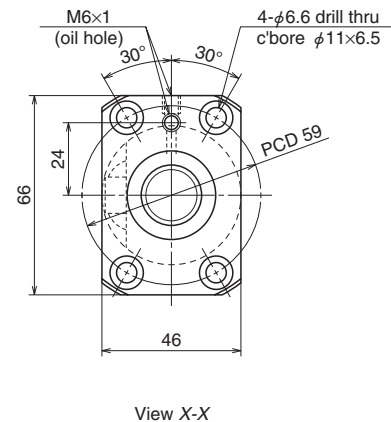

Ball screw specifications			
Product classification	Preloaded	Precise clearance	
Shaft dia. x Lead / Direction of turn	20 x 10 / Right		
Preload / Ball recirculation	P-preload / Return tube		
Ball dia. / Ball circle dia.	3.969 / 21		
Screw shaft root diameter	16.9		
Effective turns of balls	2.5 x 1		
Accuracy grade / Preload / Axial play	C5 / Z	C5 / T	
Basic load rating (N)	Dynamic C_d	6 880	10 900
	Static C_0	10 800	21 700
Axial play	0	0.005 or less	
Preload (N)	196	—	
Dynamic friction torque, (N-cm)	2.0 - 11.8	2.9 or less	
Spacer ball	Yes	None	
Factory-packed grease	NSK grease LR3		
Internal spatial volume of nut (cm ³)	4.7		
Standard volume of grease replenishing (cm ³)	2.4		

Recommended support unit

For drive side (Fixed)	For opposite to drive side (Simple)
WBK15-01A (square)	WBK15S-01 (square)
WBK15-11 (round)	

Unit: mm

Ball screw No.		Stroke	
		Nominal	Maximum
Preloaded (LPFT)	Precise clearance (LSFT)		
W2002FA-1P-C5Z10	W2002FA-2-C5T10	200	229
W2003FA-1P-C5Z10	W2003FA-2-C5T10	300	329
W2004FA-1P-C5Z10	W2004FA-2-C5T10	400	429
W2005FA-1P-C5Z10	W2005FA-2-C5T10	500	529
W2006FA-1P-C5Z10	W2006FA-2-C5T10	600	629
W2007FA-1P-C5Z10	W2007FA-2-C5T10	700	729
W2008FA-1P-C5Z10	W2008FA-2-C5T10	800	829
W2009FA-1P-C5Z10	W2009FA-2-C5T10	900	929
W2010FA-1P-C5Z10	W2010FA-2-C5T10	1 000	1 029
W2011FA-1P-C5Z10	W2011FA-2-C5T10	1 100	1 129
W2012FA-1P-C5Z10	W2012FA-2-C5T10	1 200	1 229

- Notes:
1. We recommend NSK support unit. See page B389 for details.
 2. Use of NSK grease LR3 is recommended. Recommended quantity of grease is about 50% of ball nut's internal space. See page D16 for details.
 3. Contact NSK if the permissible rotational speed is to be exceeded.

Screw shaft length			Lead accuracy			Shaft run-out **	Mass (kg)	Permissible rotational speed N (min ⁻¹)	
L_t	L_a	L_o	T	e_p	v_s			Supporting condition	
								Fixed - Simple support	Fixed - Fixed
289	314	399	0	0.023	0.018	0.035	1.4	3 000	3 000
389	414	499	0	0.025	0.020	0.040	1.6	3 000	3 000
489	514	599	0	0.027	0.020	0.050	1.9	3 000	3 000
589	614	699	0	0.030	0.023	0.065	2.1	3 000	3 000
689	714	799	0	0.035	0.025	0.065	2.3	3 000	3 000
789	814	899	0	0.035	0.025	0.085	2.5	3 000	3 000
889	914	999	0	0.040	0.027	0.085	2.8	3 000	3 000
989	1 014	1 099	0	0.040	0.027	0.110	3.0	2 710	3 000
1 089	1 114	1 199	0	0.046	0.030	0.110	3.2	2 220	3 000
1 189	1 214	1 299	0	0.046	0.030	0.150	3.4	1 860	2 570
1 289	1 314	1 399	0	0.054	0.035	0.150	3.7	1 580	2 190

- Notes:
4. If Fixed is used for opposite driven side, configuration of support bearing area is designed by the customer.
 5. See B51 and B52 for ball screw supporting method (Fixed-Supported, Fixed-Fixed, etc.).

Finished shaft end FA Type

(High helix lead)

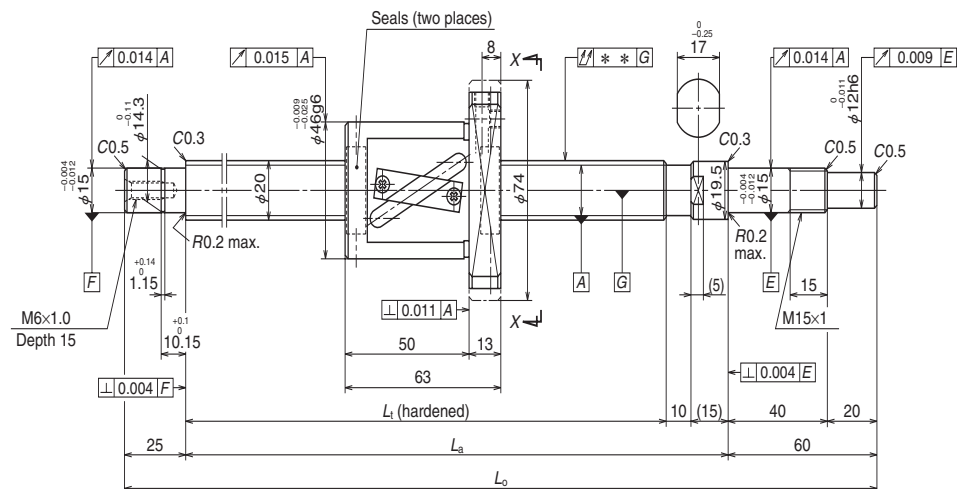

Nut models: LPFT, LSFT

NSK

Screw shaft ø20

Lead 20

Unit: mm

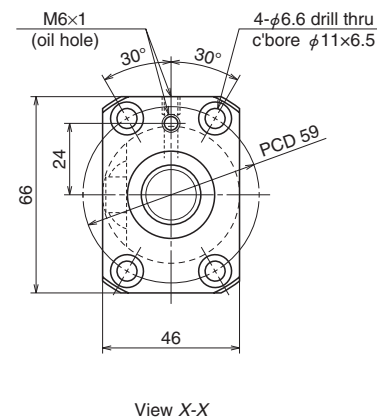

Recommended support unit

	For drive side (Fixed)	For opposite to drive side (Simple)
	WBK15-01A (square)	WBK15S-01 (square)
	WBK15-11 (round)	

Ball screw specifications		
Product classification	Preloaded	Precise clearance
Shaft dia. x Lead / Direction of turn	20 x 20 / Right	
Preload / Ball recirculation	P-preload / Return tube	
Ball dia. / Ball circle dia.	3.969 / 21	
Screw shaft root diameter	16.9	
Effective turns of balls	1.5 x 1	
Accuracy grade / Preload / Axial play	C5 / Z	C5 / T
Basic load rating (N)	Dynamic C_a	5 370
	Static C_{0a}	8 450
Axial play	0	0.005 or less
Preload (N)	196	—
Dynamic friction torque, (N-cm)	2.0 - 11.8	2.9 or less
Spacer ball	Yes	None
Factory-packed grease	NSK grease LR3	
Internal spatial volume of nut (cm ³)	4.2	
Standard volume of grease replenishing (cm ³)	2.1	

Unit: mm

Ball screw No.		Stroke	
		Nominal	Maximum
Preloaded (LPFT)	Precise clearance (LSFT)		
W2003FA-3P-C5Z20	W2003FA-4-C5T20	200	241
W2004FA-3P-C5Z20	W2004FA-4-C5T20	300	341
W2005FA-3P-C5Z20	W2005FA-4-C5T20	400	441
W2006FA-3P-C5Z20	W2006FA-4-C5T20	500	541
W2007FA-3P-C5Z20	W2007FA-4-C5T20	600	641
W2008FA-3P-C5Z20	W2008FA-4-C5T20	700	741
W2009FA-3P-C5Z20	W2009FA-4-C5T20	800	841
W2010FA-3P-C5Z20	W2010FA-4-C5T20	900	941
W2011FA-3P-C5Z20	W2011FA-4-C5T20	1 000	1 040
W2012FA-3P-C5Z20	W2012FA-4-C5T20	1 100	1 141
W2015FA-1P-C5Z20	W2015FA-2-C5T20	1 400	1 441

- Notes: 1. We recommend NSK support unit. See page B389 for details.
 2. Use of NSK grease LR3 is recommended. Recommended quantity of grease is about 50% of ball nut's internal space. See page D16 for details.
 3. Contact NSK if the permissible rotational speed is to be exceeded.

Screw shaft length			Lead accuracy			Shaft run-out **	Mass (kg)	Permissible rotational speed N (min ⁻¹)	
L_t	L_a	L_o	T	e_p	v_a			Supporting condition	
								Fixed - Simple support	Fixed - Fixed
310	335	420	0	0.023	0.018	0.040	1.6	3 000	3 000
410	435	520	0	0.027	0.020	0.050	1.8	3 000	3 000
510	535	620	0	0.030	0.023	0.050	2.0	3 000	3 000
610	635	720	0	0.030	0.023	0.065	2.3	3 000	3 000
710	735	820	0	0.035	0.025	0.085	2.5	3 000	3 000
810	835	920	0	0.040	0.027	0.085	2.7	3 000	3 000
910	935	1 020	0	0.040	0.027	0.110	3.0	3 000	3 000
1 010	1 035	1 120	0	0.046	0.030	0.110	3.2	2 630	3 000
1 110	1 135	1 220	0	0.046	0.030	0.110	3.4	2 160	2 970
1 210	1 235	1 320	0	0.046	0.030	0.150	3.7	1 810	2 500
1 510	1 535	1 620	0	0.054	0.035	0.180	4.4	1 150	1 610

- Notes: 4. If Fixed is used for opposite driven side, configuration of support bearing area is designed by the customer.
 5. See B51 and B52 for ball screw supporting method (Fixed-Supported, Fixed-Fixed, etc.).

Finished shaft end FA Type

(Ultra high helix lead)

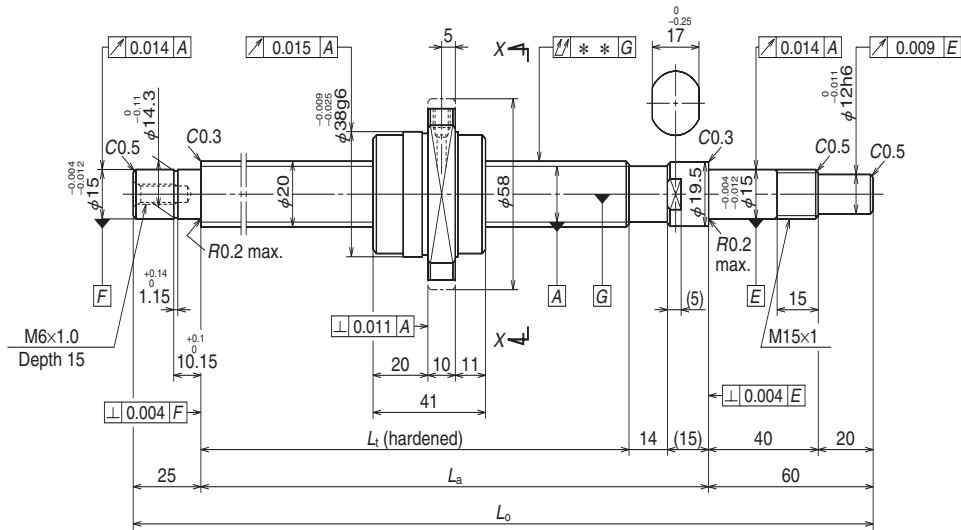

Nut models: UPFC, USFC

NSK

Screw shaft ø20

Lead 40

Unit: mm

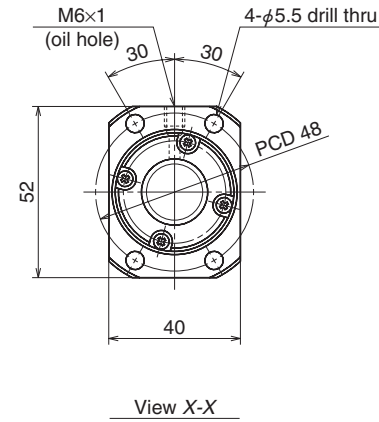

Ball screw specifications		
Product classification	Preloaded	Precise clearance
Shaft dia. x Lead / Direction of turn	20 x 40 / Right	
Preload / Ball recirculation	P-preload / End cap	
Ball dia. / Ball circle dia.	3.175 / 20.75	
Screw shaft root diameter	17.4	
Effective turns of balls	0.7 x 2	
Accuracy grade / Preload / Axial play	C5 / Z	C5 / T
Basic load rating (N)	Dynamic C_d	4 490
	Static C_0	8 640
Axial play	0	0.005 or less
Preload (N)	148	—
Dynamic friction torque, (N-cm)	2.0 - 11.8	2.9 or less
Spacer ball	None	
Factory-packed grease	NSK grease LR3	
Internal spatial volume of nut (cm ³)	2.8	
Standard volume of grease replenishing (cm ³)	1.4	

Recommended support unit

For drive side (Fixed)	For opposite to drive side (Simple)
WBK15-01A (square)	WBK15S-01 (square)
WBK15-11 (round)	

Unit: mm

Ball screw No.		Stroke	
		Nominal	Maximum
Preloaded (UPFC)	Precise clearance (USFC)		
W2005FA-5PGX-C5Z40	W2005FA-6GX-C5T40	400	459
W2007FA-5PGX-C5Z40	W2007FA-6GX-C5T40	600	659
W2009FA-5PGX-C5Z40	W2009FA-6GX-C5T40	800	859
W2011FA-5PGX-C5Z40	W2011FA-6GX-C5T40	1 000	1 059
W2013FA-1PGX-C5Z40	W2013FA-2GX-C5T40	1 200	1 259
W2017FA-1PGX-C5Z40	W2017FA-2GX-C5T40	1 600	1 659

- Notes:
1. We recommend NSK support unit. See page B389 for details.
 2. Use of NSK grease LR3 is recommended. Recommended quantity of grease is about 50% of ball nut's internal space. See page D16 for details.
 3. Ball nut does not have seal.
 4. Contact NSK if the permissible rotational speed is to be exceeded.

Screw shaft length			Lead accuracy			Shaft run-out **	Mass (kg)	Permissible rotational speed N (min ⁻¹)	
L_t	L_a	L_o	T	e_p	v_a			Supporting condition	
								Fixed - Simple support	Fixed - Fixed
506	535	620	0	0.030	0.023	0.050	1.7	3 000	3 000
706	735	820	0	0.035	0.025	0.085	2.2	3 000	3 000
906	935	1 020	0	0.040	0.027	0.110	2.7	3 000	3 000
1 106	1 135	1 220	0	0.046	0.030	0.110	3.1	2 210	3 000
1 306	1 335	1 420	0	0.054	0.035	0.150	3.6	1 570	2 160
1 706	1 735	1 820	0	0.065	0.040	0.230	4.6	910	1 270

- Notes:
5. If Fixed is used for opposite driven side, configuration of support bearing area is designed by the customer.
 6. See B51 and B52 for ball screw supporting method (Fixed-Supported, Fixed-Fixed, etc.).

Finished shaft end FA Type

(Medium lead)

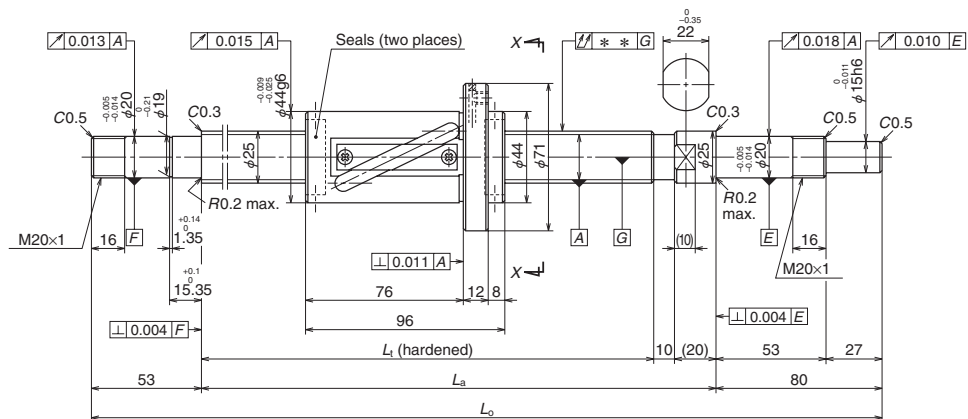

Nut models: LPFT, LSFT

NSK

Screw shaft $\phi 25$

Lead 20

Unit: mm

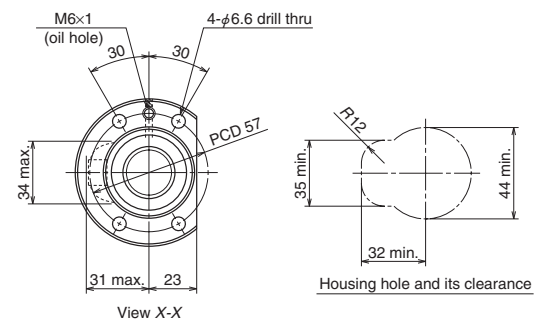

Ball screw specifications			
Product classification	Preloaded	Precise clearance	
Shaft dia. x Lead / Direction of turn	25 x 20 / Right		
Preload / Ball recirculation	P-preload / Return tube		
Ball dia. / Ball circle dia.	4.762 / 26.25		
Screw shaft root diameter	21.3		
Effective turns of balls	2.5 x 1		
Accuracy grade / Preload / Axial play	C5 / Z	C5 / T	
Basic load rating (N)	Dynamic C_d	9 900	15 700
	Static C_0	16 400	32 800
Axial play	0	0.005 or less	
Preload (N)	343	—	
Dynamic friction torque, (N-cm)	3.9 - 24.5	4.9 or less	
Spacer ball	Yes	None	
Factory-packed grease	NSK grease LR3		
Internal spatial volume of nut (cm ³)	12		
Standard volume of grease replenishing (cm ³)	6		

Recommended support unit

For drive side (Fixed)	For opposite to drive side	
	(Fixed)	(Simple)
WBK20-01 (square)	WBK20-01 (square)	WBK20S-01 (square)
WBK20-11 (round)	WBK20-11 (round)	

Unit: mm

Ball screw No.		Stroke	
		Nominal	Maximum
Preloaded (LPFT)	Precise clearance (LSFT)		
W2507FA-1P-C5Z20	W2507FA-2-C5T20	600	640
W2509FA-1P-C5Z20	W2509FA-2-C5T20	800	840
W2511FA-1P-C5Z20	W2511FA-2-C5T20	1 000	1 040
W2513FA-1P-C5Z20	W2513FA-2-C5T20	1 200	1 240
W2515FA-1P-C5Z20	W2515FA-2-C5T20	1 400	1 440
W2517FA-1P-C5Z20	W2517FA-2-C5T20	1 600	1 640
W2521FA-1P-C5Z20	W2521FA-2-C5T20	2 000	2 040

- Notes:
- We recommend NSK support unit. See page B389 for details.
 - Use of NSK grease LR3 is recommended. Recommended quantity of grease is about 50% of ball nut's internal space. See page D16 for details.
 - Contact NSK if the permissible rotational speed is to be exceeded.

Screw shaft length			Lead accuracy			Shaft run-out **	Mass (kg)	Permissible rotational speed N (min ⁻¹)	
L_1	L_a	L_0	T	e_p	v_u			Supporting condition	
								Fixed - Simple support	Fixed - Fixed
750	780	913	0	0.035	0.025	0.055	4.0	2 800	2 800
950	980	1 113	0	0.040	0.027	0.070	4.7	2 800	2 800
1 150	1 180	1 313	0	0.046	0.030	0.090	5.4	2 590	2 800
1 350	1 380	1 513	0	0.054	0.035	0.090	6.2	1 860	2 550
1 550	1 580	1 713	0	0.054	0.035	0.120	6.9	1 400	1 940
1 750	1 780	1 913	0	0.065	0.040	0.120	7.6	1 090	1 520
2 150	2 180	2 313	0	0.077	0.046	0.160	9.1	720	1 000

Finished shaft end FA Type

(High helix lead)

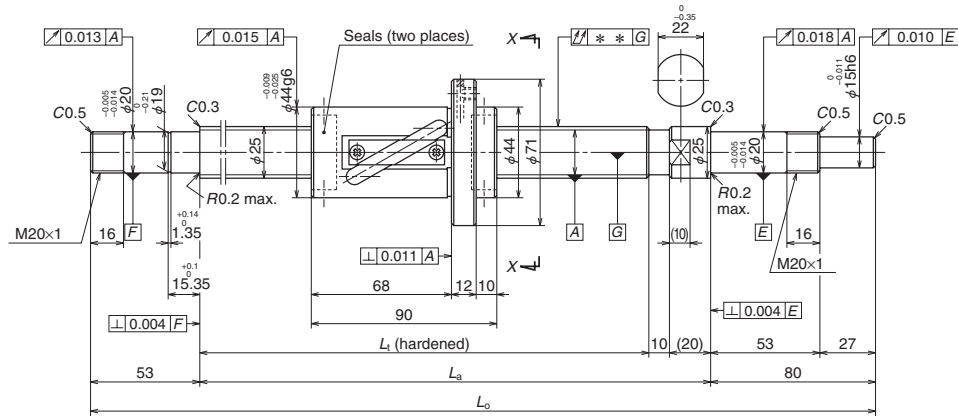

Nut models: LPFT, LSFT

NSK

Screw shaft ø25

Lead 25

Unit: mm

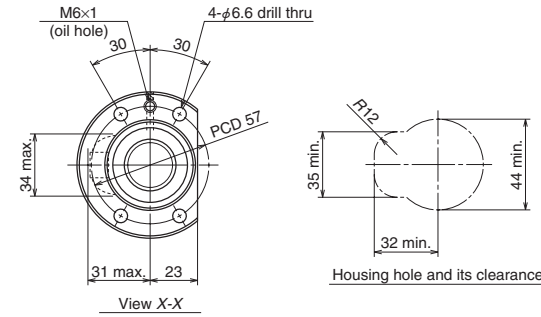

Ball screw specifications			
Product classification	Preloaded	Precise clearance	
Shaft dia. x Lead / Direction of turn	25 x 25 / Right		
Preload / Ball recirculation	P-preload / Return tube		
Ball dia. / Ball circle dia.	4.762 / 26.25		
Screw shaft root diameter	21.3		
Effective turns of balls	1.5 x 1		
Accuracy grade / Preload / Axial play	C5 / Z	C5 / T	
Basic load rating (N)	Dynamic C_d	7 730	10 100
	Static C_0	12 700	19 100
Axial play	0	0.005 or less	
Preload (N)	294	—	
Dynamic friction torque, (N-cm)	3.9 - 24.5	4.9	
Spacer ball	Yes	None	
Factory-packed grease	NSK grease LR3		
Internal spatial volume of nut (cm ³)	7.5		
Standard volume of grease replenishing (cm ³)	3.8		

Recommended support unit

For drive side (Fixed)	For opposite to drive side	
	(Fixed)	(Simple)
WBK20-01 (square)	WBK20-01 (square)	WBK20S-01 (square)
WBK20-11 (round)	WBK20-11 (round)	

Unit: mm

Ball screw No.		Stroke	
		Nominal	Maximum
Preloaded (LPFT)	Precise clearance (LSFT)		
W2507FA-3P-C5Z25	W2507FA-4-C5T25	600	646
W2509FA-3P-C5Z25	W2509FA-4-C5T25	800	846
W2511FA-3P-C5Z25	W2511FA-4-C5T25	1 000	1 046
W2513FA-3P-C5Z25	W2513FA-4-C5T25	1 200	1 246
W2515FA-3P-C5Z25	W2515FA-4-C5T25	1 400	1 446
W2517FA-3P-C5Z25	W2517FA-4-C5T25	1 600	1 646
W2521FA-3P-C5Z25	W2521FA-4-C5T25	2 000	2 046

Screw shaft length			Lead accuracy			Shaft run-out **	Mass (kg)	Permissible rotational speed N (min ⁻¹)	
L_1	L_a	L_b	T	e_p	v_u			Supporting condition	
								Fixed - Simple support	Fixed - Fixed
750	780	913	0	0.035	0.025	0.055	4.0	2 800	2 800
950	980	1 113	0	0.040	0.027	0.070	4.7	2 800	2 800
1 150	1 180	1 313	0	0.046	0.030	0.090	5.4	2 580	2 800
1 350	1 380	1 513	0	0.054	0.035	0.090	6.2	1 850	2 550
1 550	1 580	1 713	0	0.054	0.035	0.120	7.0	1 400	1 930
1 750	1 780	1 913	0	0.065	0.040	0.120	7.7	1 090	1 510
2 150	2 180	2 313	0	0.077	0.046	0.160	9.1	710	1 000

- Notes:
1. We recommend NSK support unit. See page B389 for details.
 2. Use of NSK grease LR3 is recommended. Recommended quantity of grease is about 50% of ball nut's internal space. See page D16 for details.
 3. Contact NSK if the permissible rotational speed is to be exceeded.

Finished shaft end FA Type

(Ultra high helix lead)

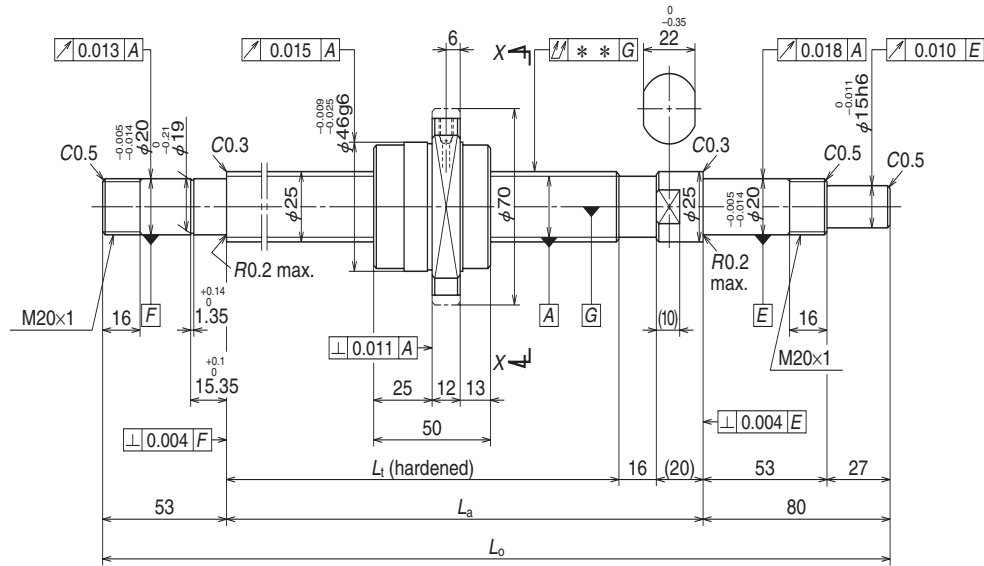

Nut models: UPFC, USFC

NSK

Screw shaft $\phi 25$

Lead 50

Unit: mm

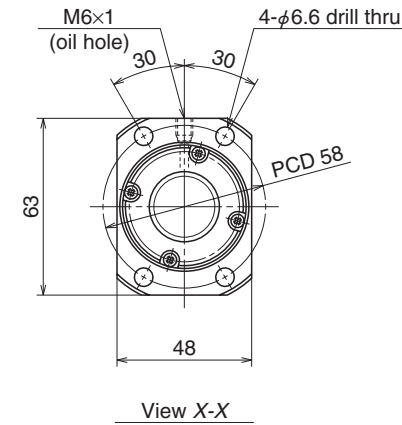

Ball screw specifications

Product classification		Preloaded	Precise clearance
Shaft dia. x Lead / Direction of turn		25 x 50 / Right	
Preload / Ball recirculation		P-preload / End cap	
Ball dia. / Ball circle dia.		3.969 / 26	
Screw shaft root diameter		21.9	
Effective turns of balls		0.7 x 2	
Accuracy grade / Preload / Axial play		C5 / Z	C5 / T
Basic load rating (N)	Dynamic C_d	6 690	
	Static C_0	13 500	
Axial play		0	0.005 or less
Preload (N)		196	—
Dynamic friction torque, (N-cm)		2.9 - 21.5	4.9 or less
Spacer ball		None	
Factory-packed grease		NSK grease LR3	
Internal spatial volume of nut (cm ³)		4.2	
Standard volume of grease replenishing (cm ³)		2.1	

Recommended support unit

For drive side (Fixed)	For opposite to drive side (Fixed) (Simple)	
WBK20-01 (square)	WBK20-01 (square)	WBK20S-01 (square)
WBK20-11 (round)	WBK20-11 (round)	

Unit: mm

Ball screw No.		Stroke	
		Nominal	Maximum
Preloaded (UPFC)	Precise clearance (USFC)		
W2508FA-1PGX-C5Z50	W2508FA-2GX-C5T50	700	780
W2511FA-5PGX-C5Z50	W2511FA-6GX-C5T50	1 000	1 080
W2516FA-1PGX-C5Z50	W2516FA-2GX-C5T50	1 500	1 580
W2521FA-5PGX-C5Z50	W2521FA-6GX-C5T50	2 000	2 080

- Notes: 1. We recommend NSK support unit. See page B389 for details.
 2. Use of NSK grease LR3 is recommended. Recommended quantity of grease is about 50% of ball nut's internal space. See page D16 for details.
 3. Ball nut does not have seal.
 4. Contact NSK if the permissible rotational speed is to be exceeded.

Screw shaft length			Lead accuracy			Shaft run-out **	Mass (kg)	Permissible rotational speed N (min ⁻¹)	
L_t	L_a	L_o	T	e_p	v_a			Supporting condition	
								Fixed - Simple support	Fixed - Fixed
844	880	1 013	0	0.040	0.027	0.070	4.1	2 800	2 800
1 144	1 180	1 313	0	0.046	0.030	0.090	5.3	2 600	2 800
1 644	1 680	1 813	0	0.065	0.040	0.120	7.2	1 250	1 720
2 144	2 180	2 313	0	0.077	0.046	0.160	9.1	730	1 010

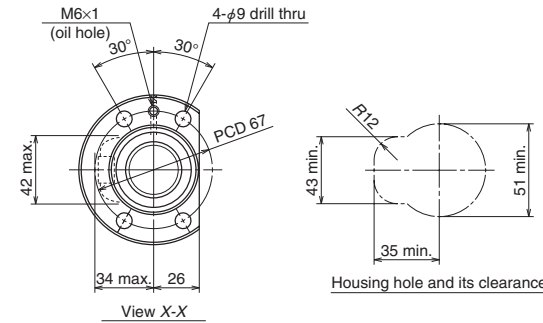
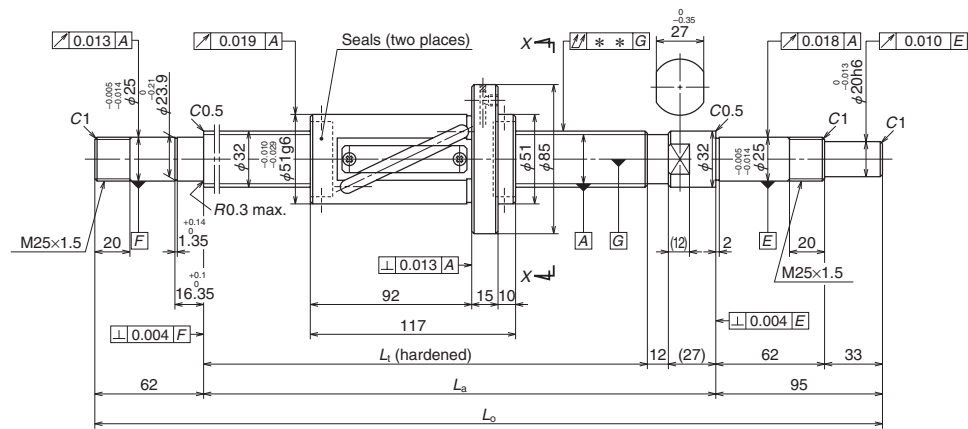

Ball screw specifications			
Product classification	Preloaded	Precise clearance	
Shaft dia. x Lead / Direction of turn	32 x 25 / Right		
Preload / Ball recirculation	P-preload / Return tube		
Ball dia. / Ball circle dia.	4.762 / 33.25		
Screw shaft root diameter	28.3		
Effective turns of balls	2.5 x 1		
Accuracy grade / Preload / Axial play	C5 / Z	C5 / T	
Basic load rating (N)	Dynamic C ₀	11 300	17 900
	Static C _{0a}	20 900	41 800
Axial play	0	0.005 or less	
Preload (N)	441	—	
Dynamic friction torque, (N-cm)	6.8 - 31.5	7.8 or less	
Spacer ball	Yes	None	
Factory-packed grease	NSK grease LR3		
Internal spatial volume of nut (cm ³)	17.5		
Standard volume of grease replenishing (cm ³)	8.8		

Recommended support unit

For drive side (Fixed)	For opposite to drive side (Fixed) (Simple)	
WBK25-01W (square)	WBK25-01W (square)	WBK25S-01W (square)
WBK25-11 (round)	WBK25-11 (round)	

Unit: mm

Ball screw No.		Stroke	
		Nominal	Maximum
Preloaded (LPFT)	Precise clearance (LSFT)		
W3211FA-1P-C5Z25	W3211FA-2-C5T25	1 000	1 046
W3216FA-1P-C5Z25	W3216FA-2-C5T25	1 500	1 546
W3221FA-1P-C5Z25	W3221FA-2-C5T25	2 000	2 046
W3227FA-1P-C5Z25	W3227FA-2-C5T25	2 600	2 646

- Notes: 1. We recommend NSK support unit. See page B389 for details.
 2. Use of NSK grease LR3 is recommended. Recommended quantity of grease is about 50% of ball nut's internal space. See page D16 for details.
 3. Contact NSK if the permissible rotational speed is to be exceeded.

Screw shaft length			Lead accuracy			Shaft run-out **	Mass (kg)	Permissible rotational speed N (min ⁻¹)	
								Supporting condition	
L _t	L _a	L _o	T	e _p	v _u		Fixed - Simple support	Fixed - Fixed	
1 180	1 219	1 376	0	0.046	0.030	0.090	9.3	2 180	2 180
1 680	1 719	1 876	0	0.065	0.040	0.120	12.3	1 600	2 180
2 180	2 219	2 376	0	0.077	0.046	0.160	15.4	930	1 300
2 780	2 819	2 976	0	0.093	0.054	0.200	19.1	570	800

Finished shaft end FA Type

(High helix lead)

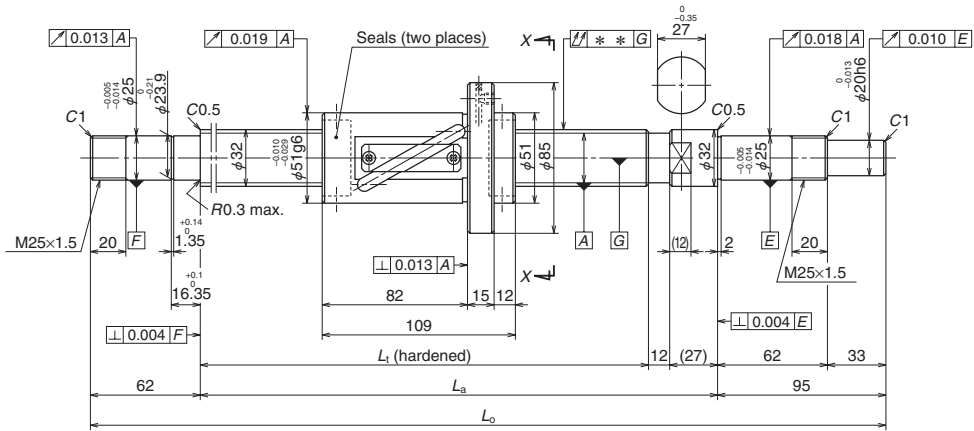

Nut models: LPFT, LSFT

NSK

Screw shaft $\phi 32$

Lead 32

Unit: mm

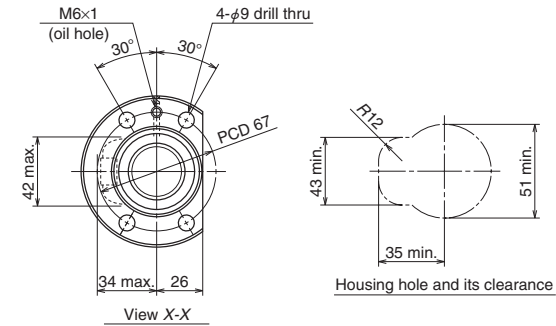

Ball screw specifications			
Product classification	Preloaded	Precise clearance	
Shaft dia. x Lead / Direction of turn	32 x 32 / Right		
Preload / Ball recirculation	P-preload / Return tube		
Ball dia. / Ball circle dia.	4.762 / 33.25		
Screw shaft root diameter	28.3		
Effective turns of balls	1.5 x 1		
Accuracy grade / Preload / Axial play	C5 / Z	C5 / T	
Basic load rating (N)	Dynamic C_d	8 800	11 500
	Static C_0	16 600	24 800
Axial play	0	0.005 or less	
Preload (N)	392	—	
Dynamic friction torque, (N-cm)	6.9 - 31.5	7.8 or less	
Spacer ball	Yes	None	
Factory-packed grease	NSK grease LR3		
Internal spatial volume of nut (cm ³)	14		
Standard volume of grease replenishing (cm ³)	7		

Recommended support unit

For drive side (Fixed)	For opposite to drive side	
	(Fixed)	(Simple)
WBK25-01W (square)	WBK25-01W (square)	WBK25S-01W (square)
WBK25-11 (round)	WBK25-11 (round)	

Unit: mm

Ball screw No.		Stroke	
		Nominal	Maximum
Preloaded (LPFT)	Precise clearance (LSFT)		
W3211FA-3P-C5Z32	W3211FA-4-C5T32	1 000	1 054
W3216FA-3P-C5Z32	W3216FA-4-C5T32	1 500	1 554
W3221FA-3P-C5Z32	W3221FA-4-C5T32	2 000	2 054
W3227FA-3P-C5Z32	W3227FA-4-C5T32	2 600	2 654

Screw shaft length			Lead accuracy			Shaft run-out **	Mass (kg)	Permissible rotational speed N (min ⁻¹)	
								Supporting condition	
L_t	L_a	L_o	T	e_p	v_u		Fixed - Simple support	Fixed - Fixed	
1 180	1 219	1 376	0	0.046	0.030	0.090	9.3	2 180	2 180
1 680	1 719	1 876	0	0.065	0.040	0.120	12.3	1 590	2 180
2 180	2 219	2 376	0	0.077	0.046	0.160	15.4	930	1 290
2 780	2 819	2 976	0	0.093	0.054	0.200	19.1	570	790

- Notes: 1. We recommend NSK support unit. See page B389 for details.
 2. Use of NSK grease LR3 is recommended. Recommended quantity of grease is about 50% of ball nut's internal space. See page D16 for details.
 3. Contact NSK if the permissible rotational speed is to be exceeded.

Finished shaft end SA Type

(Fine lead)

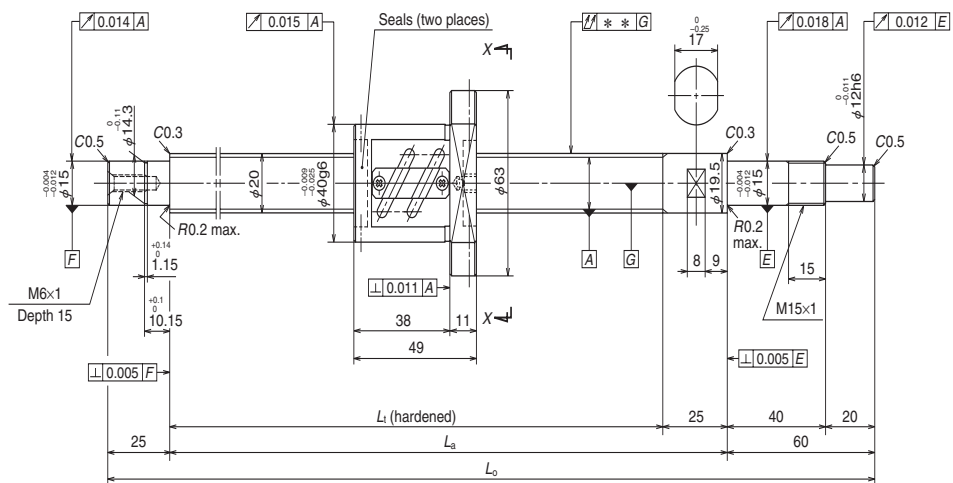

Nut model: PFT

NSK

Screw shaft ø20

Lead 4

Unit: mm

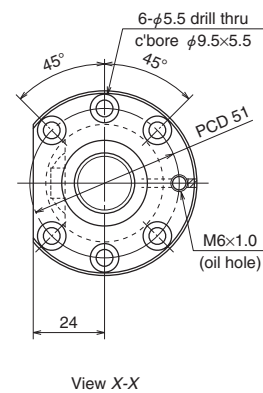

Ball screw specifications

Shaft dia. x Lead / Direction of turn	20 x 4 / Right	
Preload / Ball recirculation	P-preload / Return tube	
Ball dia. / Ball circle dia.	2.381 / 20.3	
Effective turns of balls	2.5 x 2	
Screw shaft root diameter	17.8	
Accuracy grade / Preload	C5 / Z	
Basic load rating (N)	Dynamic C_d	5 420
	Static C_0	10 700
Preload (N)	294	
Dynamic friction torque, median, (N·cm)	3.9	
Spacer ball	Yes	
Factory-packed grease	Refer to NOTES 2.	
Internal spatial volume of nut (cm ³)	2.7	
Standard volume of grease replenishing (cm ³)	1.4	

Recommended support unit

For drive side (Fixed)	For opposite to drive side (Simple)
WBK15-01A (square)	WBK15S-01 (square)
WBK15-11 (round)	

Unit: mm

Ball screw No.	Stroke		Screw shaft length		
	Nominal	Maximum	L_1	L_a	L_0
W2002SA-1P-C5Z4	150	170	225	250	335
W2002SA-2P-C5Z4	200	220	275	300	385
W2003SA-1P-C5Z4	300	320	375	400	485
W2004SA-1P-C5Z4	400	420	475	500	585
W2005SA-1P-C5Z4	500	520	575	600	685
W2006SA-1P-C5Z4	600	620	675	700	785

Lead accuracy			Shaft run-out **	Mass (kg)	Permissible rotational speed N (min ⁻¹)	
T	e_p	v_u			Supporting condition	
					Fixed - Simple support	Fixed - Fixed
-0.005	0.023	0.018	0.045	1.1	3 000	3 000
-0.007	0.023	0.018	0.045	1.2	3 000	3 000
-0.009	0.025	0.020	0.055	1.5	3 000	3 000
-0.011	0.027	0.020	0.070	1.7	3 000	3 000
-0.014	0.030	0.023	0.085	1.9	3 000	3 000
-0.016	0.035	0.025	0.085	2.1	3 000	3 000

Notes: 1. We recommend NSK support unit. See page B389 for details.

2. Only rust preventive agent is applied at time of delivery. Please apply lubricant (oil or grease) before use. See page D13 for details.

3. Contact NSK if the permissible rotational speed is to be exceeded.

4. If Fixed is used for opposite driven side, configuration of support bearing area is designed by the customer.

5. See B51 and B52 for ball screw supporting method (Fixed-Supported, Fixed-Fixed, etc.).

Finished shaft end SA Type

(Fine lead)

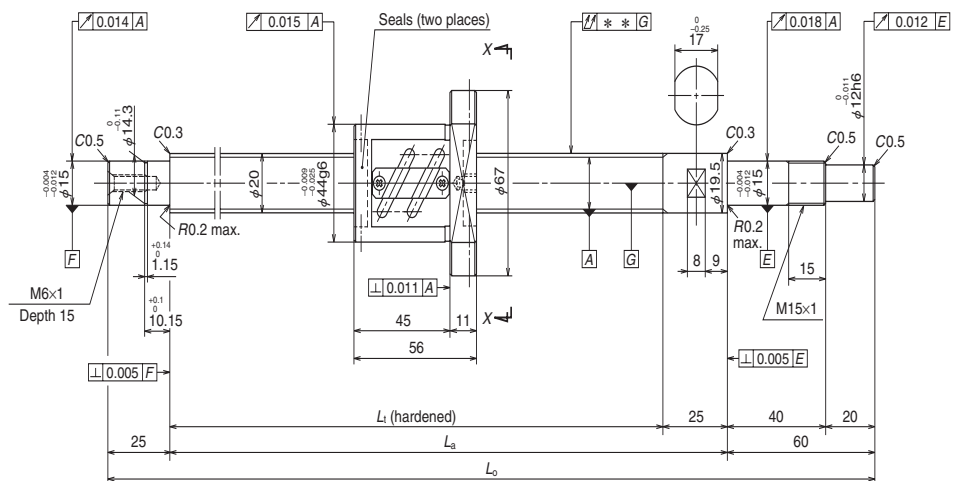

Nut model: PFT

NSK

Screw shaft ø20

Lead 5

Unit: mm

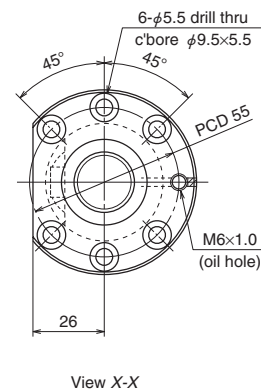

Ball screw specifications		
Shaft dia. x Lead / Direction of turn	20 x 5 / Right	
Preload / Ball recirculation	P-preload / Return tube	
Ball dia. / Ball circle dia.	3.175 / 20.5	
Screw shaft root diameter	17.2	
Effective turns of balls	2.5 x 2	
Accuracy grade / Preload	C5 / Z	
Basic load rating (N)	Dynamic C_d	9 410
	Static C_{0a}	17 100
Preload (N)	490	
Dynamic friction torque, median, (N·cm)	7.8	
Spacer ball	Yes	
Factory-packed grease	Refer to NOTES 2.	
Internal spatial volume of nut (cm ³)	4.3	
Standard volume of grease replenishing (cm ³)	2.2	

Recommended support unit

For drive side (Fixed)	For opposite to drive side (Simple)
WBK15-01A (square)	WBK15S-01 (square)
WBK15-11 (round)	

Unit: mm

Ball screw No.	Stroke		Screw shaft length		
	Nominal	Maximum	L_t	L_a	L_o
W2002SA-3P-C5Z5	150	163	225	250	335
W2002SA-4P-C5Z5	200	213	275	300	385
W2003SA-2P-C5Z5	300	313	375	400	485
W2004SA-2P-C5Z5	400	413	475	500	585
W2005SA-2P-C5Z5	500	513	575	600	685
W2007SA-1P-C5Z5	700	713	775	800	885

Lead accuracy			Shaft run-out ** μ	Mass (kg)	Permissible rotational speed N (min ⁻¹)	
T	e_p	v_u			Supporting condition	
					Fixed - Simple support	Fixed - Fixed
-0.005	0.023	0.018	0.045	1.3	3 000	3 000
-0.007	0.023	0.018	0.045	1.4	3 000	3 000
-0.009	0.025	0.020	0.055	1.6	3 000	3 000
-0.011	0.027	0.020	0.070	1.8	3 000	3 000
-0.014	0.030	0.023	0.085	2.0	3 000	3 000
-0.019	0.035	0.025	0.110	2.5	3 000	3 000

- Notes: 1. We recommend NSK support unit. See page B389 for details.
 2. **Only rust preventive agent is applied at time of delivery. Please apply lubricant (oil or grease) before use.** See page D13 for details.
 3. Contact NSK if the permissible rotational speed is to be exceeded.
 4. If Fixed is used for opposite driven side, configuration of support bearing area is designed by the customer.
 5. See B51 and B52 for ball screw supporting method (Fixed-Supported, Fixed-Fixed, etc.).

Finished shaft end SA Type

(Fine lead)

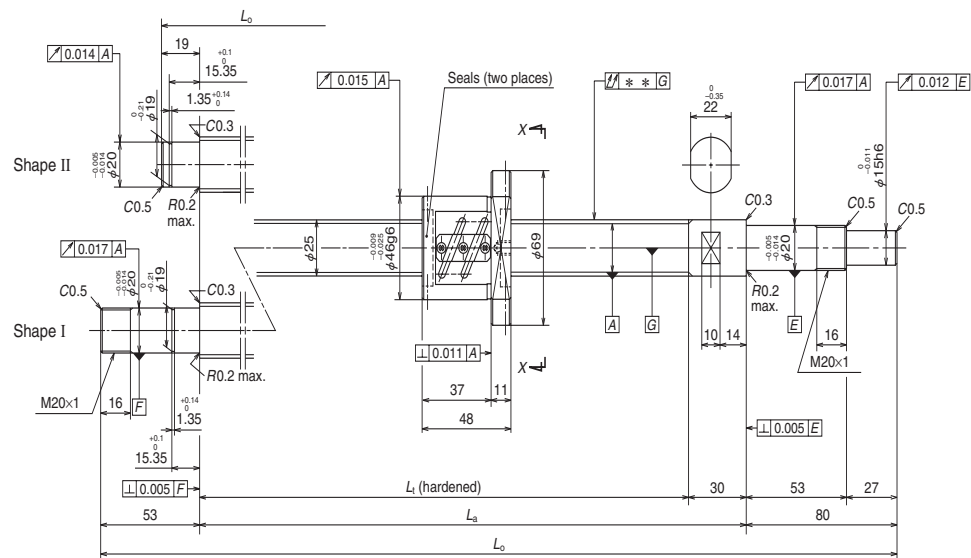

Nut model: PFT

NSK

Screw shaft ø25

Lead 4

Unit: mm

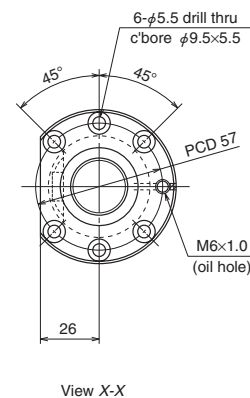

Ball screw specifications		
Shaft dia. x Lead / Direction of turn	25 x 4 / Right	
Preload / Ball recirculation	P-preload / Return tube	
Ball dia. / Ball circle dia.	2.381 / 25.3	
Screw shaft root diameter	22.8	
Effective turns of balls	2.5 x 2	
Accuracy grade / Preload	C5 / Z	
Basic load rating (N)	Dynamic C_d	6 020
	Static C_0	13 600
Preload (N)	290	
Dynamic friction torque, median, (N·cm)	4.9	
Spacer ball	Yes	
Factory-packed grease	Refer to NOTES 2.	
Internal spatial volume of nut (cm ³)	3.2	
Standard volume of grease replenishing (cm ³)	1.6	

Recommended support unit

For drive side (Fixed)	For opposite to drive side	
	(Fixed)	(Simple)
WBK20-01 (square)	WBK20-01 (square)	WBK20S-01 (square)
WBK20-11 (round)	WBK20-11 (round)	

Unit: mm

Ball screw No.	Stroke		Screw shaft length		
	Nominal	Maximum	L_t	L_a	L_o
W2502SA-1P-C5Z4	150	166	220	250	349
W2502SA-2P-C5Z4	200	216	270	300	399
W2503SA-1P-C5Z4	300	316	370	400	499
W2504SA-1P-C5Z4	400	416	470	500	599
W2505SA-1P-C5Z4	500	516	570	600	733
W2507SA-1P-C5Z4	700	716	770	800	933

Left side shaft end	Lead accuracy			Shaft run-out **	Mass (kg)	Permissible rotational speed N (min ⁻¹)	
	T	e_o	v_u			Supporting condition	
						Fixed - Simple support	Fixed - Fixed
II	-0.005	0.023	0.018	0.035	1.6	2 800	—
II	-0.006	0.023	0.018	0.035	1.8	2 800	—
II	-0.009	0.025	0.020	0.040	2.2	2 800	—
II	-0.011	0.027	0.020	0.050	2.5	2 800	—
I	-0.014	0.030	0.023	0.060	3.0	2 800	2 800
I	-0.018	0.035	0.025	0.075	3.7	2 800	2 800

- Notes: 1. We recommend NSK support unit. See page B389 for details.
 2. Only rust preventive agent is applied at time of delivery. Please apply lubricant (oil or grease) before use. See page D13 for details.
 3. Contact NSK if the permissible rotational speed is to be exceeded.
 4. The maximum stroke is -8 mm when Fixed-Fixed is used for left shaft end shape I.

Finished shaft end SA Type

(Fine lead)

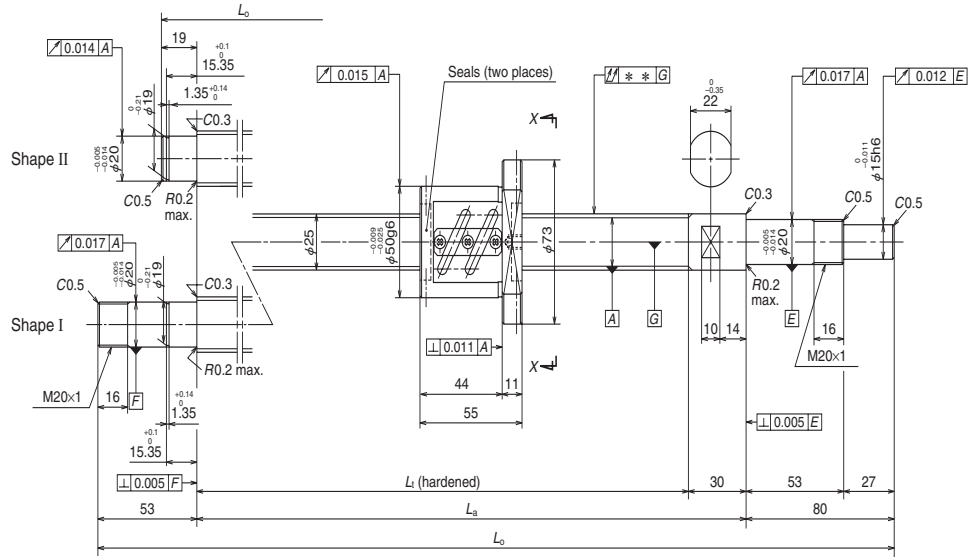

Nut model: PFT

NSK

Screw shaft ø25

Lead 5

Unit: mm

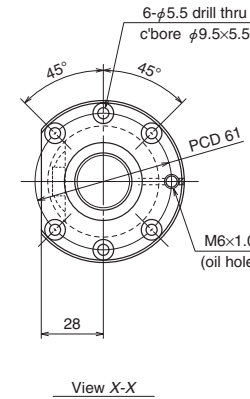

Ball screw specifications		
Shaft dia. x Lead / Direction of turn	25 × 5 / Right	
Preload / Ball recirculation	P-preload / Return tube	
Ball dia. / Ball circle dia.	3.175 / 25.5	
Screw shaft root diameter	22.2	
Effective turns of balls	2.5 × 2	
Accuracy grade / Preload	C5 / Z	
Basic load rating (N)	Dynamic C_d	10 400
	Static C_{0a}	21 900
Preload (N)	540	
Dynamic friction torque, median, (N·cm)	8.8	
Spacer ball	Yes	
Factory-packed grease	Refer to NOTES 2.	
Internal spatial volume of nut (cm ³)	5.0	
Standard volume of grease replenishing (cm ³)	2.5	

Recommended support unit

For drive side (Fixed)	For opposite to drive side	
	(Fixed)	(Simple)
WBK20-01 (square)	WBK20-01 (square)	WBK20S-01 (square)
WBK20-11 (round)	WBK20-11 (round)	

Unit: mm

Ball screw No.	Stroke		Screw shaft length		
	Nominal	Maximum	L_t	L_a	L_o
W2502SA-3P-C5Z5	150	159	220	250	349
W2502SA-4P-C5Z5	200	209	270	300	399
W2503SA-2P-C5Z5	300	309	370	400	499
W2504SA-2P-C5Z5	400	409	470	500	599
W2505SA-2P-C5Z5	500	509	570	600	733
W2506SA-1P-C5Z5	600	609	670	700	833
W2507SA-2P-C5Z5	700	709	770	800	933
W2509SA-1P-C5Z5	900	909	970	1 000	1 133
W2511SA-1P-C5Z5	1 100	1 109	1 170	1 200	1 333

Left side shaft end	Lead accuracy			Shaft run-out **	Mass (kg)	Permissible rotational speed N (min ⁻¹)	
	T	e_o	v_u			Supporting condition	
						Fixed - Simple support	Fixed - Fixed
II	-0.005	0.023	0.018	0.035	1.8	2 800	—
II	-0.006	0.023	0.018	0.035	2.0	2 800	—
II	-0.009	0.025	0.020	0.040	2.3	2 800	—
II	-0.011	0.027	0.020	0.050	2.7	2 800	—
I	-0.014	0.030	0.023	0.060	3.1	2 800	2 800
I	-0.016	0.035	0.025	0.075	3.4	2 800	2 800
I	-0.018	0.035	0.025	0.075	3.8	2 800	2 800
I	-0.023	0.040	0.027	0.090	4.5	2 800	2 800
I	-0.028	0.046	0.030	0.120	5.2	2 520	2 800

- Notes: 1. We recommend NSK support unit. See page B389 for details.
 2. Only rust preventive agent is applied at time of delivery. Please apply lubricant (oil or grease) before use. See page D13 for details.
 3. Contact NSK if the the permissible rotational speed is to be exceeded.
 4. The maximum stroke is -8 mm when Fixed-Fixed is used for left shaft end shape I.

Finished shaft end SA Type

(Fine lead)

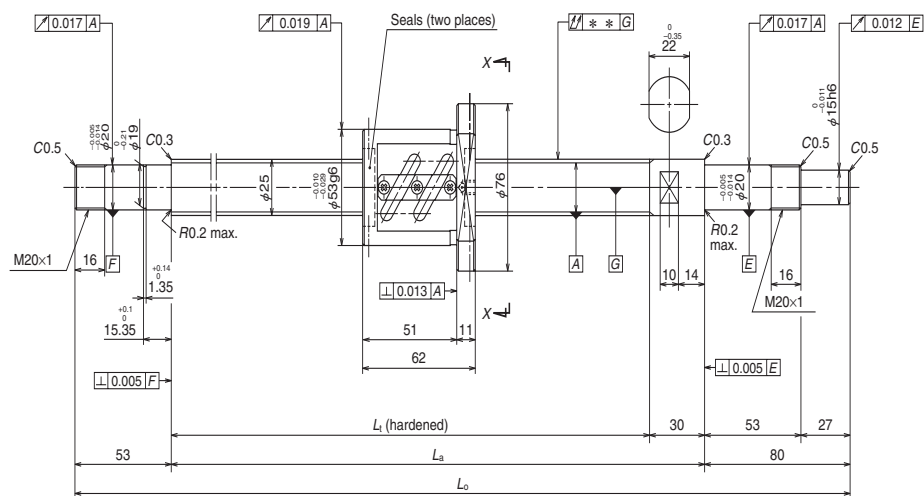

Nut model: PFT

NSK

Screw shaft ø25

Lead 6

Unit: mm

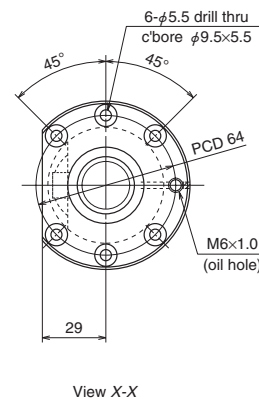

Ball screw specifications

Shaft dia. x Lead / Direction of turn	25 × 6 / Right	
Preload / Ball recirculation	P-preload / Return tube	
Ball dia. / Ball circle dia.	3.969 / 25.5	
Screw shaft root diameter	21.4	
Effective turns of balls	2.5 × 2	
Accuracy grade / Preload	C5 / Z	
Basic load rating (N)	Dynamic C_d	14 100
	Static C_{0a}	26 800
Preload (N)	685	
Dynamic friction torque, median, (N·cm)	13.8	
Spacer ball	Yes	
Factory-packed grease	Refer to NOTES 2.	
Internal spatial volume of nut (cm ³)	7.0	
Standard volume of grease replenishing (cm ³)	3.5	

Recommended support unit

For drive side (Fixed)	For opposite to drive side	
	(Fixed)	(Simple)
WBK20-01 (square)	WBK20-01 (square)	WBK20S-01 (square)
WBK20-11 (round)	WBK20-11 (round)	

Unit: mm

Ball screw No.	Stroke		Screw shaft length		
	Nominal	Maximum	L_t	L_a	L_o
W2503SA-3P-C5Z6	250	302	370	400	533
W2505SA-3P-C5Z6	450	502	570	600	733
W2507SA-3P-C5Z6	650	702	770	800	933
W2511SA-2P-C5Z6	1 050	1 102	1 170	1 200	1 333

Lead accuracy			Shaft run-out **	Mass (kg)	Permissible rotational speed N (min ⁻¹)	
T	e_p	v_u			Supporting condition	
					Fixed - Simple support	Fixed - Fixed
-0.009	0.025	0.020	0.050	2.5	2 800	2 800
-0.014	0.030	0.023	0.060	3.2	2 800	2 800
-0.018	0.035	0.025	0.075	3.9	2 800	2 800
-0.028	0.046	0.030	0.120	5.2	2 450	2 800

Notes: 1. We recommend NSK support unit. See page B389 for details.

2. **Only rust preventive agent is applied at time of delivery. Please apply lubricant (oil or grease) before use.** See page D13 for details.

3. Contact NSK if the permissible rotational speed is to be exceeded.

4. The maximum stroke is -8 mm when Fixed-Fixed is used.

Finished shaft end SA Type

(Fine lead)

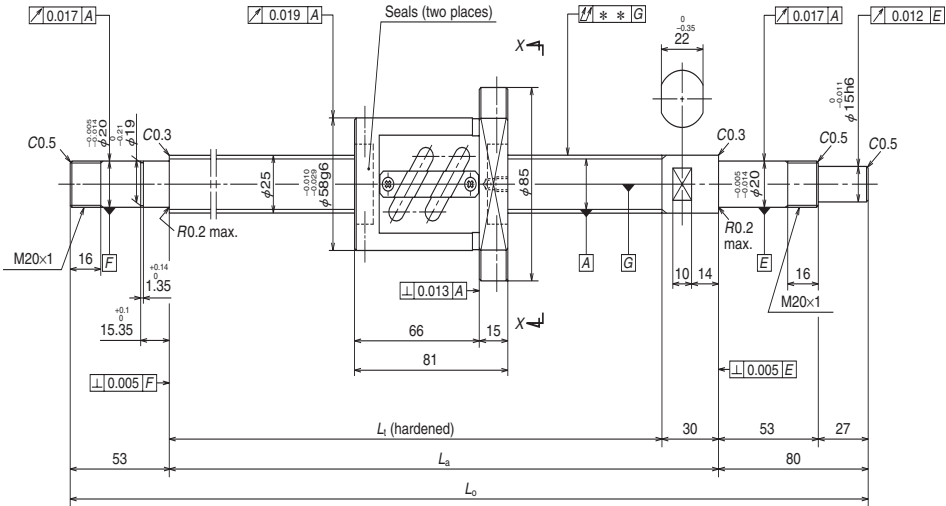

Nut model: PFT

NSK

Screw shaft $\phi 25$

Lead 10

Unit: mm

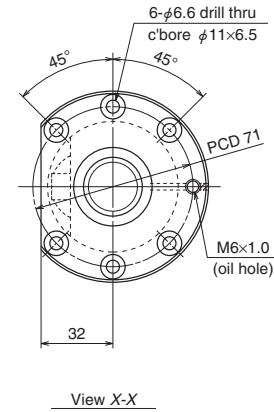

Ball screw specifications

Shaft dia. x Lead / Direction of turn	25 x 10 / Right	
Preload / Ball recirculation	P-preload / Return tube	
Ball dia. / Ball circle dia.	4.762 / 25.5	
Screw shaft root diameter	20.5	
Effective turns of balls	1.5 x 2	
Accuracy grade / Preload	C5 / Z	
Basic load rating (N)	Dynamic C_d	11 600
	Static C_{0a}	19 000
Preload (N)	585	
Dynamic friction torque, median, (N·cm)	13.8	
Spacer ball	Yes	
Factory-packed grease	Refer to NOTES 2.	
Internal spatial volume of nut (cm ³)	9.5	
Standard volume of grease replenishing (cm ³)	4.8	

Recommended support unit

For drive side (Fixed)	For opposite to drive side	
	(Fixed)	(Simple)
WBK20-01 (square)	WBK20-01 (square)	WBK20S-01 (square)
WBK20-11 (round)	WBK20-11 (round)	

Unit: mm

Ball screw No.	Stroke		Screw shaft length		
	Nominal	Maximum	L_t	L_a	L_o
W2503SA-4P-C5Z10	250	283	370	400	533
W2505SA-4P-C5Z10	450	483	570	600	733
W2507SA-4P-C5Z10	650	683	770	800	933
W2509SA-2P-C5Z10	850	883	970	1 000	1 133
W2511SA-3P-C5Z10	1 050	1 083	1 170	1 200	1 333
W2514SA-1P-C5Z10	1 350	1 383	1 470	1 500	1 633

Lead accuracy			Shaft run-out **	Mass (kg)	Permissible rotational speed N (min ⁻¹)	
T	e_p	v_u			Supporting condition	
					Fixed - Simple support	Fixed - Fixed
-0.009	0.025	0.020	0.050	3.2	2 800	2 800
-0.014	0.030	0.023	0.060	3.8	2 800	2 800
-0.018	0.035	0.025	0.075	4.5	2 800	2 800
-0.023	0.040	0.027	0.090	5.2	2 800	2 800
-0.028	0.046	0.030	0.120	5.9	2 390	2 800
-0.035	0.054	0.035	0.150	6.9	1 490	2 060

Notes: 1. We recommend NSK support unit. See page B389 for details.

2. Only rust preventive agent is applied at time of delivery. Please apply lubricant (oil or grease) before use. See page D13 for details.

3. Contact NSK if the permissible rotational speed is to be exceeded.

4. The maximum stroke is -8 mm when Fixed-Fixed is used.

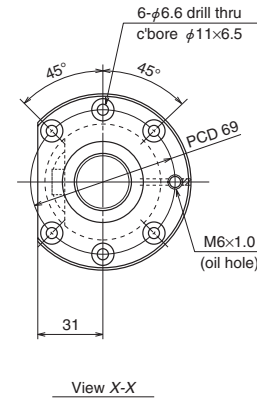
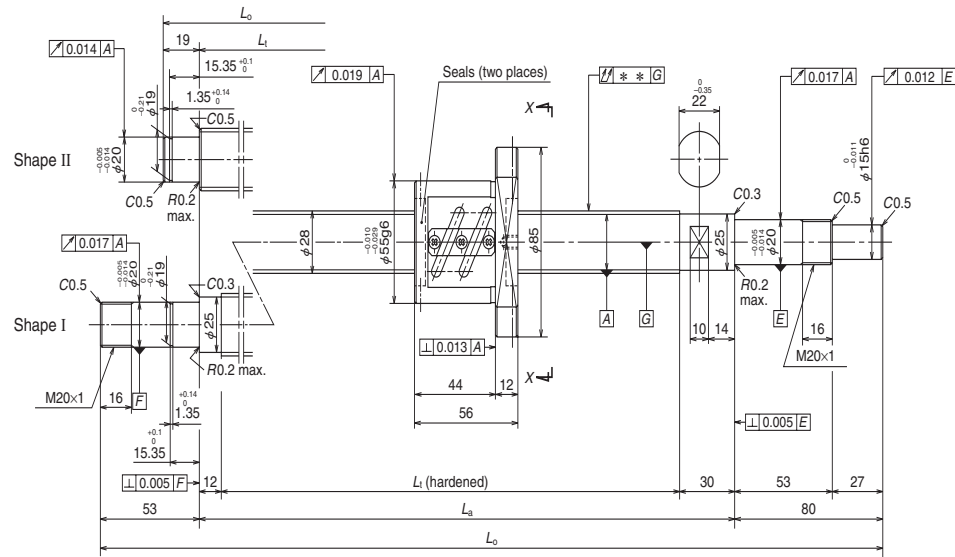

Ball screw specifications

Shaft dia. x Lead / Direction of turn	28 × 5 / Right	
Preload / Ball recirculation	P-preload / Return tube	
Ball dia. / Ball circle dia.	3.175 / 28.5	
Screw shaft root diameter	25.2	
Effective turns of balls	2.5 × 2	
Accuracy grade / Preload	C5 / Z	
Basic load rating (N)	Dynamic C_d	11 000
	Static C_0	24 400
Preload (N)	540	
Dynamic friction torque, median, (N·cm)	9.8	
Spacer ball	Yes	
Factory-packed grease	Refer to NOTES 2.	
Internal spatial volume of nut (cm ³)	6.0	
Standard volume of grease replenishing (cm ³)	3.0	

Recommended support unit

For drive side (Fixed)	For opposite to drive side	
	(Fixed)	(Simple)
WBK20-01 (square)	WBK20-01 (square)	WBK20S-01 (square)
WBK20-11 (round)	WBK20-11 (round)	

Ball screw No.	Stroke		Screw shaft length		
	Nominal	Maximum	L_t	L_a	L_0
W2802SA-1P-C5Z5	200	208	270	300	399
W2803SA-1P-C5Z5	300	308	370	400	499
W2804SA-1P-C5Z5	400	408	470	500	599
W2805SA-1P-C5Z5	450	502	558	600	733
W2807SA-1P-C5Z5	650	702	758	800	933
W2809SA-1P-C5Z5	850	902	958	1 000	1 133
W2811SA-1P-C5Z5	1 050	1 102	1 158	1 200	1 333

- Notes: 1. We recommend NSK support unit. See page B389 for details.
 2. **Only rust preventive agent is applied at time of delivery. Please apply lubricant (oil or grease) before use.** See page D13 for details.
 3. Contact NSK if the permissible rotational speed is to be exceeded.
 4. The maximum stroke is -2 mm when Fixed-Fixed is used for left shaft end shape I.

Left side shaft end	Lead accuracy			Shaft run-out ** $\uparrow \downarrow$	Mass (kg)	Permissible rotational speed N (min ⁻¹)	
	T	e_0	v_u			Supporting condition	
						Fixed - Simple support	Fixed - Fixed
II	-0.006	0.023	0.018	0.035	2.5	2 500	—
II	-0.009	0.025	0.020	0.040	2.9	2 500	—
II	-0.011	0.027	0.020	0.050	3.3	2 500	—
I	-0.014	0.030	0.023	0.060	3.8	2 500	2 500
I	-0.018	0.035	0.025	0.075	4.7	2 500	2 500
I	-0.024	0.040	0.027	0.090	5.6	2 500	2 500
I	-0.028	0.046	0.030	0.120	6.5	2 500	2 500

Finished shaft end SA Type

(Fine lead)

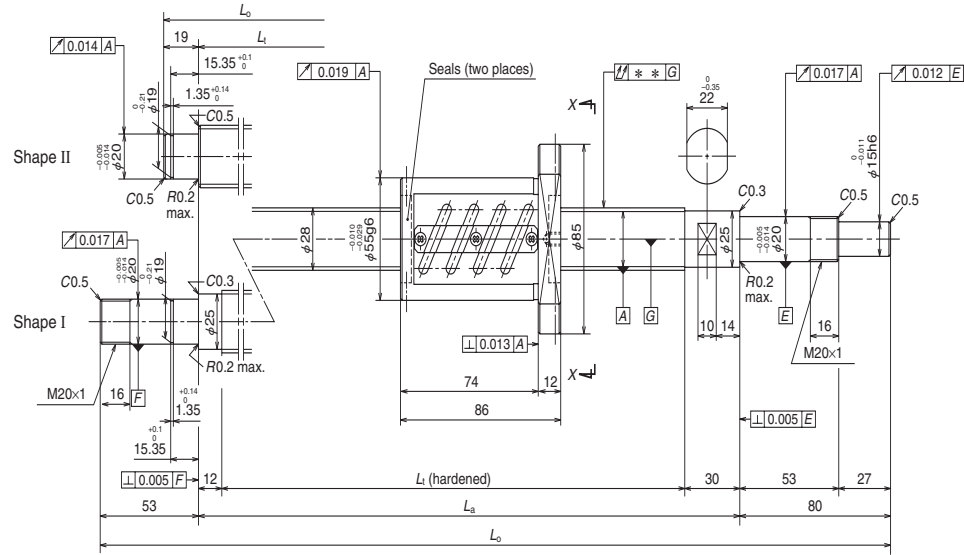

Nut model: ZFT

NSK

Screw shaft ø28

Lead 5

Unit: mm

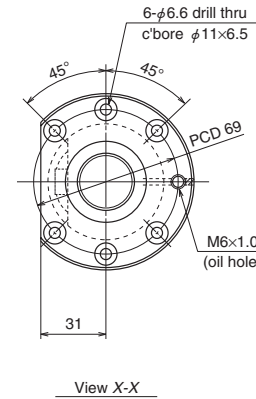

Ball screw specifications

Shaft dia. x Lead / Direction of turn	28 x 5 / Right	
Preload / Ball recirculation	Z-preload / Return tube	
Ball dia. / Ball circle dia.	3.175 / 28.5	
Screw shaft root diameter	25.2	
Effective turns of balls	2.5 x 2	
Accuracy grade / Preload	C5 / Z	
Basic load rating (N)	Dynamic C_d	17 400
	Static C_{0a}	48 800
Preload (N)	1 220	
Dynamic friction torque, median, (N·cm)	21.5	
Spacer ball	None	
Factory-packed grease	Refer to NOTES 2.	
Internal spatial volume of nut (cm ³)	9.0	
Standard volume of grease replenishing (cm ³)	4.5	

Recommended support unit

For drive side (Fixed)	For opposite to drive side	
	(Fixed)	(Simple)
WBK20-01 (square)	WBK20-01 (square)	WBK20S-01 (square)
WBK20-11 (round)	WBK20-11 (round)	

Unit: mm

Ball screw No.	Stroke		Screw shaft length		
	Nominal	Maximum	L_t	L_a	L_o
W2802SA-2Z-C5Z5	150	178	270	300	399
W2803SA-2Z-C5Z5	250	278	370	400	499
W2804SA-2Z-C5Z5	350	378	470	500	599
W2805SA-2Z-C5Z5	450	472	558	600	733
W2807SA-2Z-C5Z5	650	672	758	800	933
W2809SA-2Z-C5Z5	850	872	958	1 000	1 133
W2811SA-2Z-C5Z5	1 050	1 072	1 158	1 200	1 333

- Notes: 1. We recommend NSK support unit. See page B389 for details.
 2. **Only rust preventive agent is applied at time of delivery. Please apply lubricant (oil or grease) before use.** See page D13 for details.
 3. Contact NSK if the permissible rotational speed is to be exceeded.
 4. The maximum stroke is -2 mm when Fixed-Fixed is used for left shaft end shape I.

Left side shaft end	Lead accuracy			Shaft run-out ** \uparrow	Mass (kg)	Permissible rotational speed N (min ⁻¹)	
	T	e_o	v_u			Supporting condition	
						Fixed - Simple support	Fixed - Fixed
II	-0.006	0.023	0.018	0.035	2.8	2 500	—
II	-0.009	0.025	0.020	0.040	3.2	2 500	—
II	-0.011	0.027	0.020	0.050	3.7	2 500	—
I	-0.013	0.030	0.023	0.060	4.2	2 500	2 500
I	-0.018	0.035	0.025	0.075	5.1	2 500	2 500
I	-0.023	0.040	0.027	0.090	5.9	2 500	2 500
I	-0.028	0.046	0.030	0.120	6.8	2 500	2 500

Finished shaft end SA Type

(Fine lead)

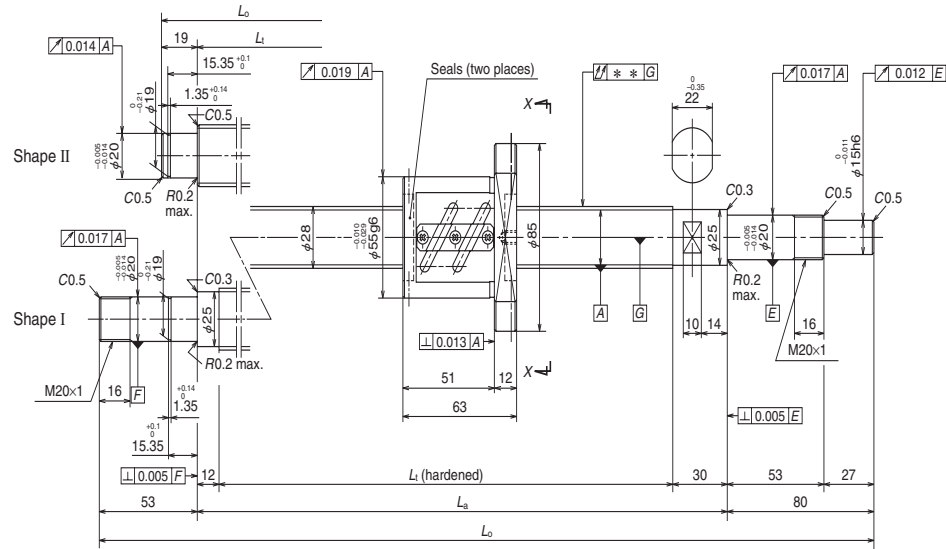

Nut model: PFT

NSK

Screw shaft ø28

Lead 6

Unit: mm

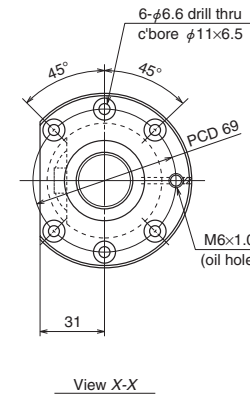

Ball screw specifications		
Shaft dia. x Lead / Direction of turn	28 × 6 / Right	
Preload / Ball recirculation	P-preload / Return tube	
Ball dia. / Ball circle dia.	3.175 / 28.5	
Screw shaft root diameter	25.2	
Effective turns of balls	2.5 × 2	
Accuracy grade / Preload	C5 / Z	
Basic load rating (N)	Dynamic C_d	11 000
	Static C_0	24 400
Preload (N)	540	
Dynamic friction torque, median, (N·cm)	11.8	
Spacer ball	Yes	
Factory-packed grease	Refer to NOTES 2.	
Internal spatial volume of nut (cm ³)	6.0	
Standard volume of grease replenishing (cm ³)	3.0	

Recommended support unit

For drive side (Fixed)	For opposite to drive side	
	(Fixed)	(Simple)
WBK20-01 (square)	WBK20-01 (square)	WBK20S-01 (square)
WBK20-11 (round)	WBK20-11 (round)	

Unit: mm

Ball screw No.	Stroke		Screw shaft length		
	Nominal	Maximum	L_t	L_a	L_o
W2803SA-3P-C5Z6	250	301	370	400	499
W2805SA-3P-C5Z6	450	501	570	600	699
W2807SA-3P-C5Z6	650	695	758	800	933
W2809SA-3P-C5Z6	850	895	958	1 000	1 133
W2811SA-3P-C5Z6	1 050	1 095	1 158	1 200	1 333

Left side shaft end	Lead accuracy			Shaft run-out **	Mass (kg)	Permissible rotational speed N (min ⁻¹)	
	T	e_p	v_u			Supporting condition	
						Fixed - Simple support	Fixed - Fixed
II	-0.009	0.025	0.020	0.040	3.0	2 500	—
II	-0.014	0.030	0.023	0.060	3.9	2 500	—
I	-0.018	0.035	0.025	0.075	4.9	2 500	2 500
I	-0.023	0.040	0.027	0.090	5.8	2 500	2 500
I	-0.028	0.046	0.030	0.120	6.6	2 500	2 500

- Notes: 1. We recommend NSK support unit. See page B389 for details.
 2. Only rust preventive agent is applied at time of delivery. Please apply lubricant (oil or grease) before use. See page D13 for details.
 3. Contact NSK if the permissible rotational speed is to be exceeded.
 4. The maximum stroke is -2 mm when Fixed-Fixed is used for left shaft end shape I.

Finished shaft end SA Type

(Fine lead)

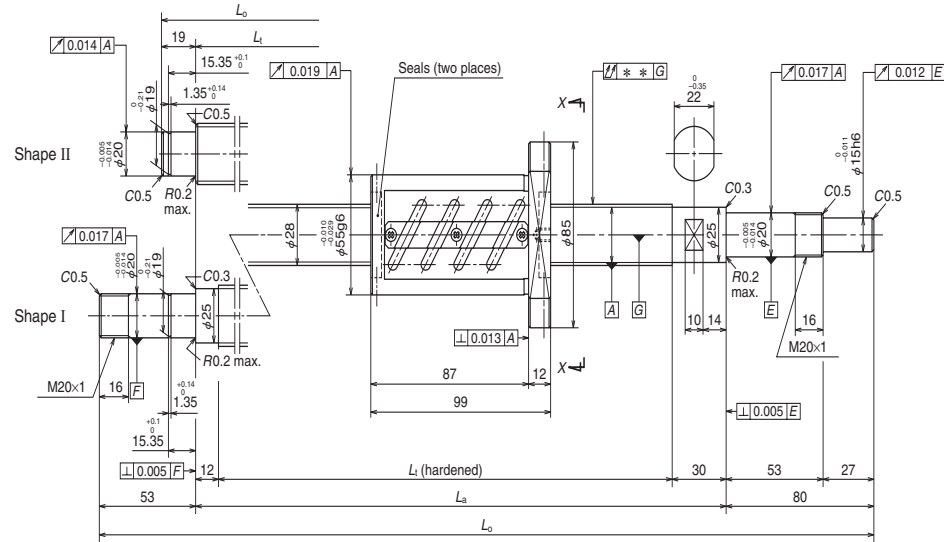

Nut model: ZFT

NSK

Screw shaft ø28

Lead 6

Unit: mm

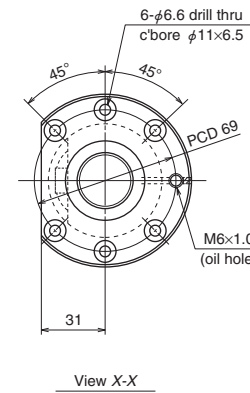

Ball screw specifications

Shaft dia. x Lead / Direction of turn	28 × 6 / Right	
Preload / Ball recirculation	Z-preload / Return tube	
Ball dia. / Ball circle dia.	3.175 / 28.5	
Screw shaft root diameter	25.2	
Effective turns of balls	2.5 × 2	
Accuracy grade / Preload	C5 / Z	
Basic load rating (N)	Dynamic C_d	17 400
	Static C_0	48 800
Preload (N)	1 220	
Dynamic friction torque, median, (N·cm)	23.5	
Spacer ball	None	
Factory-packed grease	Refer to NOTES 2.	
Internal spatial volume of nut (cm ³)	9.5	
Standard volume of grease replenishing (cm ³)	4.8	

Recommended support unit

For drive side (Fixed)	For opposite to drive side	
	(Fixed)	(Simple)
WBK20-01 (square)	WBK20-01 (square)	WBK20S-01 (square)
WBK20-11 (round)	WBK20-11 (round)	

Unit: mm

Ball screw No.	Stroke		Screw shaft length		
	Nominal	Maximum	L_t	L_a	L_o
W2803SA-4Z-C5Z6	250	265	370	400	499
W2805SA-4Z-C5Z6	450	465	570	600	699
W2807SA-4Z-C5Z6	650	659	758	800	933
W2809SA-4Z-C5Z6	850	859	958	1 000	1 133
W2811SA-4Z-C5Z6	1 050	1 059	1 158	1 200	1 333

- Notes: 1. We recommend NSK support unit. See page B389 for details.
 2. **Only rust preventive agent is applied at time of delivery. Please apply lubricant (oil or grease) before use.** See page D13 for details.
 3. Contact NSK if the permissible rotational speed is to be exceeded.
 4. The maximum stroke is -2 mm when Fixed-Fixed is used for left shaft end shape I.

Left side shaft end	Lead accuracy			Shaft run-out ** $\uparrow \downarrow$	Mass (kg)	Permissible rotational speed N (min ⁻¹)	
	T	e_p	v_u			Supporting condition	
						Fixed - Simple support	Fixed - Fixed
II	-0.009	0.025	0.020	0.040	3.4	2 500	—
II	-0.014	0.030	0.023	0.060	4.3	2 500	—
I	-0.018	0.035	0.025	0.075	5.3	2 500	2 500
I	-0.023	0.040	0.027	0.090	6.2	2 500	2 500
I	-0.028	0.046	0.030	0.120	7.1	2 500	2 500

Finished shaft end SA Type

(Fine lead)

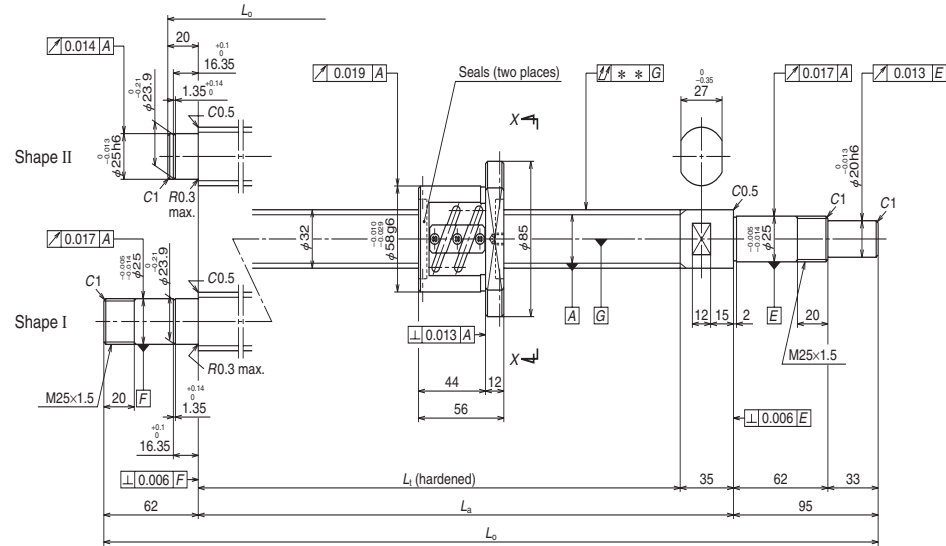

Nut model: PFT

NSK

Screw shaft ø32

Lead 5

Unit: mm

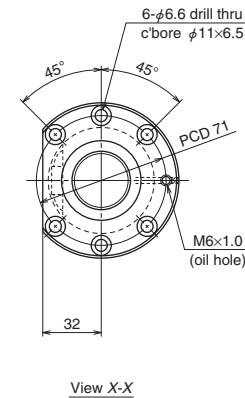

Ball screw specifications		
Shaft dia. x Lead / Direction of turn	32 x 5 / Right	
Preload / Ball recirculation	P-preload / Return tube	
Ball dia. / Ball circle dia.	3.175 / 32.5	
Screw shaft root diameter	29.2	
Effective turns of balls	2.5 x 2	
Accuracy grade / Preload	C5 / Z	
Basic load rating (N)	Dynamic C_d	11 600
	Static C_{0a}	28 000
Preload (N)	590	
Dynamic friction torque, median, (N·cm)	11.8	
Spacer ball	Yes	
Factory-packed grease	Refer to NOTES 2.	
Internal spatial volume of nut (cm ³)	7.0	
Standard volume of grease replenishing (cm ³)	3.5	

Recommended support unit

For drive side (Fixed)	For opposite to drive side	
	(Fixed)	(Simple)
WBK25-01W (square)	WBK25-01W (square)	WBK25S-01W (square)
WBK25-11 (round)	WBK25-11 (round)	

Unit: mm

Ball screw No.	Stroke		Screw shaft length		
	Nominal	Maximum	L_1	L_a	L_o
W3202SA-1P-C5Z5	150	201	265	300	415
W3203SA-1P-C5Z5	250	301	365	400	515
W3204SA-1P-C5Z5	350	401	465	500	615
W3205SA-1P-C5Z5	450	501	565	600	715
W3206SA-1P-C5Z5	550	601	665	700	857
W3207SA-1P-C5Z5	650	701	765	800	957
W3209SA-1P-C5Z5	850	901	965	1 000	1 157
W3211SA-1P-C5Z5	1 050	1 101	1 165	1 200	1 357
W3214SA-1P-C5Z5	1 350	1 401	1 465	1 500	1 657

Left side shaft end	Lead accuracy			Shaft run-out **	Mass (kg)	Permissible rotational speed N (min ⁻¹)	
	T	e_p	v_u			Supporting condition	
						Fixed - Simple support	Fixed - Fixed
II	-0.006	0.023	0.018	0.040	3.1	2 180	—
II	-0.009	0.025	0.020	0.050	3.7	2 180	—
II	-0.011	0.027	0.020	0.050	4.2	2 180	—
II	-0.014	0.030	0.023	0.060	4.8	2 180	—
I	-0.016	0.035	0.025	0.075	5.6	2 180	2 180
I	-0.018	0.035	0.025	0.075	6.1	2 180	2 180
I	-0.023	0.040	0.027	0.090	7.3	2 180	2 180
I	-0.028	0.046	0.030	0.120	8.5	2 180	2 180
I	-0.035	0.054	0.035	0.150	10.2	2 100	2 180

Notes: 1. We recommend NSK support unit. See page B389 for details.

2. Only rust preventive agent is applied at time of delivery. Please apply lubricant (oil or grease) before use. See page D13 for details.

3. Contact NSK if the permissible rotational speed is to be exceeded.

4. The maximum stroke is -9 mm when Fixed-Fixed is used for left shaft end shape I.

Finished shaft end SA Type

(Fine lead)

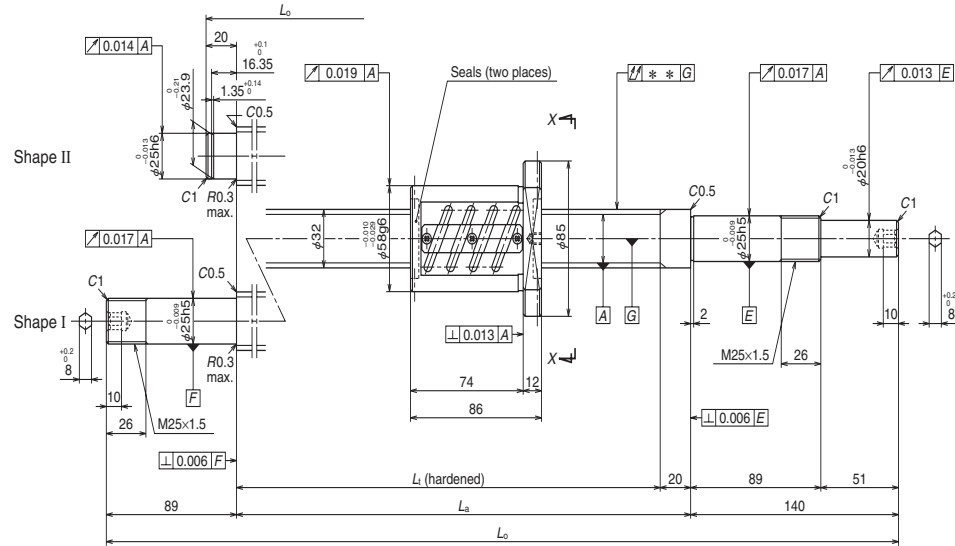

Nut model: ZFT

NSK

Screw shaft ø32

Lead 5

Unit: mm

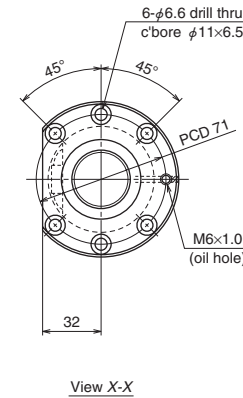

Ball screw specifications		
Shaft dia. x Lead / Direction of turn	32 × 5 / Right	
Preload / Ball recirculation	Z-preload / Return tube	
Ball dia. / Ball circle dia.	3.175 / 32.5	
Screw shaft root diameter	29.2	
Effective turns of balls	2.5 × 2	
Accuracy grade / Preload	C5 / Z	
Basic load rating (N)	Dynamic C _s	18 500
	Static C _{0a}	56 100
Preload (N)	1 270	
Dynamic friction torque, median, (N·cm)	23.5	
Spacer ball	None	
Factory-packed grease	Refer to NOTES 2.	
Internal spatial volume of nut (cm ³)	10	
Standard volume of grease replenishing (cm ³)	5	

Recommended support unit

For drive side, for opposite to drive side (Fixed)
WBK25DF-31H (round)

Unit: mm

Ball screw No.	Stroke		Screw shaft length		
	Nominal	Maximum	L _t	L _a	L _o
W3202SA-2Z-C5Z5	150	186	280	300	460
W3203SA-2Z-C5Z5	250	286	380	400	560
W3204SA-2Z-C5Z5	350	386	480	500	660
W3205SA-2Z-C5Z5	450	486	580	600	760
W3206SA-2Z-C5Z5	550	586	680	700	929
W3207SA-2Z-C5Z5	650	686	780	800	1 029
W3209SA-2Z-C5Z5	850	886	980	1 000	1 229
W3211SA-2Z-C5Z5	1 050	1 086	1 180	1 200	1 429
W3214SA-2Z-C5Z5	1 350	1 386	1 480	1 500	1 729

- Notes: 1. We recommend NSK support unit. See page B389 for details.
 2. **Only rust preventive agent is applied at time of delivery. Please apply lubricant (oil or grease) before use.** See page D13 for details.
 3. Contact NSK if the permissible rotational speed is to be exceeded.
 4. The maximum stroke is -9 mm when Fixed-Fixed is used for left shaft end shape I.

Left side shaft end	Lead accuracy			Shaft run-out **	Mass (kg)	Permissible rotational speed N (min ⁻¹)	
	T	e _p	v _u			Supporting condition	
						Fixed - Simple support	Fixed - Fixed
II	-0.007	0.023	0.018	0.040	3.5	2 180	—
II	-0.009	0.025	0.020	0.050	4.1	2 180	—
II	-0.012	0.027	0.020	0.060	4.7	2 180	—
II	-0.014	0.030	0.023	0.060	5.3	2 180	—
I	-0.016	0.035	0.025	0.075	6.1	2 180	2 180
I	-0.019	0.035	0.025	0.090	6.7	2 180	2 180
I	-0.024	0.040	0.027	0.090	7.9	2 180	2 180
I	-0.028	0.046	0.030	0.120	9.0	2 180	2 180
I	-0.036	0.054	0.035	0.150	10.8	2 100	2 180

Finished shaft end SA Type

(Fine lead)

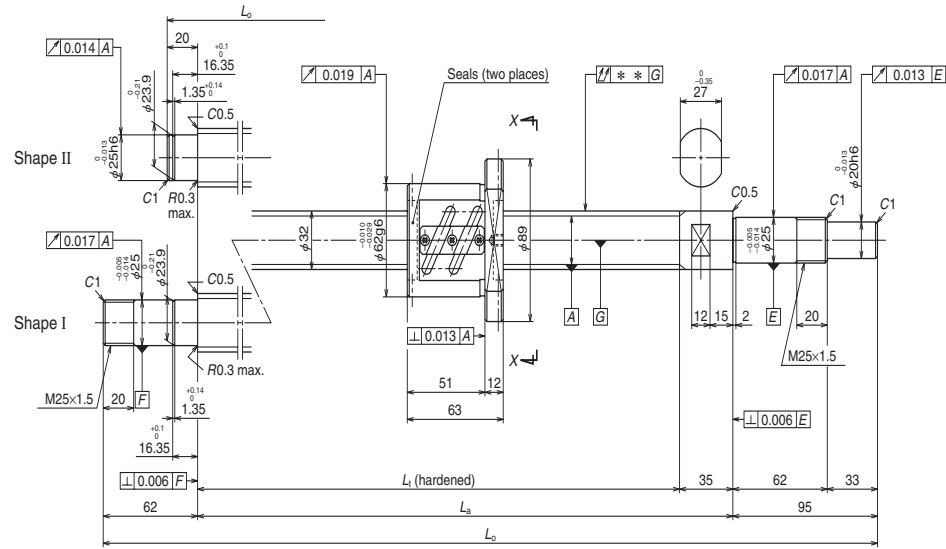

Nut model: PFT

NSK

Screw shaft ø32

Lead 6

Unit: mm

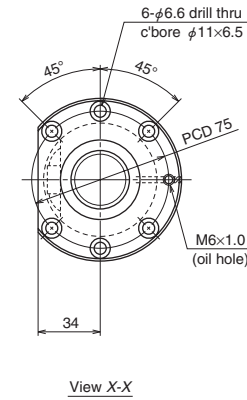

Ball screw specifications		
Shaft dia. x Lead / Direction of turn	32 x 6 / Right	
Preload / Ball recirculation	P-preload / Return tube	
Ball dia. / Ball circle dia.	3.969 / 32.5	
Screw shaft root diameter	28.4	
Effective turns of balls	2.5 x 2	
Accuracy grade / Preload	C5 / Z	
Basic load rating (N)	Dynamic C_d	15 500
	Static C_0	34 700
Preload (N)	780	
Dynamic friction torque, median, (N·cm)	15.7	
Spacer ball	Yes	
Factory-packed grease	Refer to NOTES 2.	
Internal spatial volume of nut (cm ³)	9.5	
Standard volume of grease replenishing (cm ³)	4.8	

Recommended support unit

For drive side (Fixed)	For opposite to drive side	
	(Fixed)	(Simple)
WBK25-01W (square)	WBK25-01W (square)	WBK25S-01W (square)
WBK25-11 (round)	WBK25-11 (round)	

Unit: mm

Ball screw No.	Stroke		Screw shaft length		
	Nominal	Maximum	L_1	L_a	L_o
W3203SA-3P-C5Z6	250	294	365	400	515
W3205SA-3P-C5Z6	450	494	565	600	715
W3207SA-3P-C5Z6	650	694	765	800	957
W3209SA-3P-C5Z6	850	894	965	1 000	1 157
W3211SA-3P-C5Z6	1 050	1 094	1 165	1 200	1 357
W3214SA-3P-C5Z6	1 350	1 394	1 465	1 500	1 657

Left side shaft end	Lead accuracy			Shaft run-out **	Mass (kg)	Permissible rotational speed N (min ⁻¹)	
	T	e_p	v_u			Supporting condition	
						Fixed - Simple support	Fixed - Fixed
II	-0.009	0.025	0.020	0.050	3.8	2 180	—
II	-0.014	0.030	0.023	0.060	5.0	2 180	—
I	-0.018	0.035	0.025	0.075	6.3	2 180	2 180
I	-0.023	0.040	0.027	0.090	7.4	2 180	2 180
I	-0.028	0.046	0.030	0.120	8.5	2 180	2 180
I	-0.035	0.054	0.035	0.150	10.2	2 050	2 180

- Notes: 1. We recommend NSK support unit. See page B389 for details.
 2. Only rust preventive agent is applied at time of delivery. Please apply lubricant (oil or grease) before use. See page D13 for details.
 3. Contact NSK if the permissible rotational speed is to be exceeded.
 4. The maximum stroke is -9 mm when Fixed-Fixed is used for left shaft end shape I.

Finished shaft end SA Type

(Fine lead)

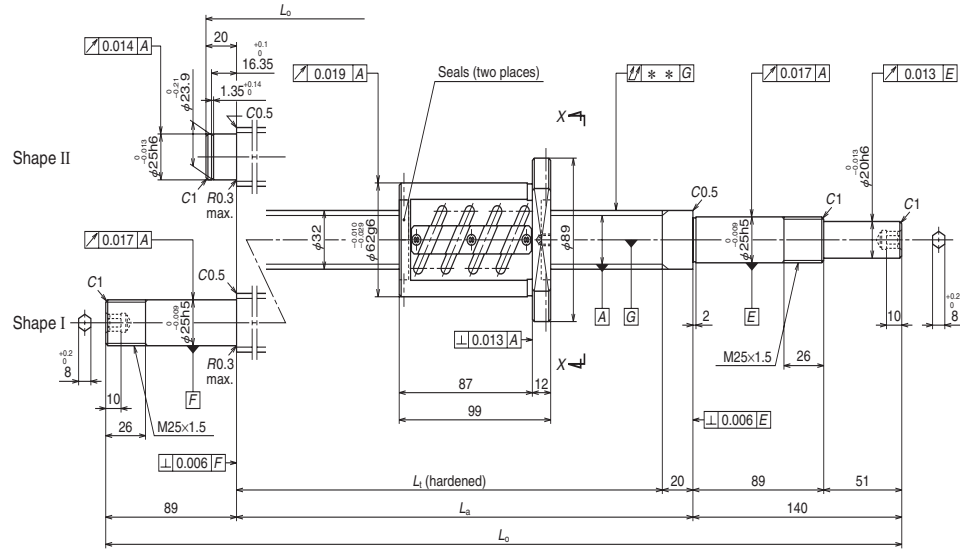

Nut model: ZFT

NSK

Screw shaft $\phi 32$

Lead 6

Unit: mm

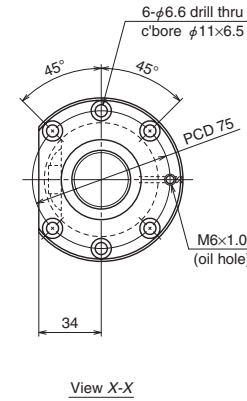

Ball screw specifications		
Shaft dia. x Lead / Direction of turn	32 x 6 / Right	
Preload / Ball recirculation	Z-preload / Return tube	
Ball dia. / Ball circle dia.	3.969 / 32.5	
Screw shaft root diameter	28.4	
Effective turns of balls	2.5 x 2	
Accuracy grade / Preload	C5 / Z	
Basic load rating (N)	Dynamic C_d	24 700
	Static C_0	69 400
Preload (N)	1 710	
Dynamic friction torque, median, (N·cm)	35.0	
Spacer ball	None	
Factory-packed grease	Refer to NOTES 2.	
Internal spatial volume of nut (cm ³)	14	
Standard volume of grease replenishing (cm ³)	7	

Recommended support unit

For drive side, for opposite to drive side (Fixed)

WBK25DF-31H (round)

Unit: mm

Ball screw No.	Stroke		Screw shaft length		
	Nominal	Maximum	L_t	L_a	L_o
W3203SA-4Z-C5Z6	250	273	380	400	560
W3205SA-4Z-C5Z6	450	473	580	600	760
W3207SA-4Z-C5Z6	650	673	780	800	1 029
W3209SA-4Z-C5Z6	850	873	980	1 000	1 229
W3211SA-4Z-C5Z6	1 050	1 073	1 180	1 200	1 429
W3214SA-4Z-C5Z6	1 350	1 373	1 480	1 500	1 729

Left side shaft end	Lead accuracy			Shaft run-out **	Mass (kg)	Permissible rotational speed N (min ⁻¹)	
	T	e_p	v_u			Supporting condition	
						Fixed - Simple support	Fixed - Fixed
II	-0.009	0.025	0.020	0.050	4.5	2 180	—
II	-0.014	0.030	0.023	0.060	5.6	2 180	—
I	-0.019	0.035	0.025	0.090	7.0	2 180	2 180
I	-0.024	0.040	0.027	0.090	8.1	2 180	2 180
I	-0.028	0.046	0.030	0.120	9.3	2 180	2 180
I	-0.036	0.054	0.035	0.150	11.0	2 060	2 180

- Notes: 1. We recommend NSK support unit. See page B389 for details.
 2. Only rust preventive agent is applied at time of delivery. Please apply lubricant (oil or grease) before use. See page D13 for details.
 3. Contact NSK if the permissible rotational speed is to be exceeded.

Finished shaft end SA Type

(Fine lead)

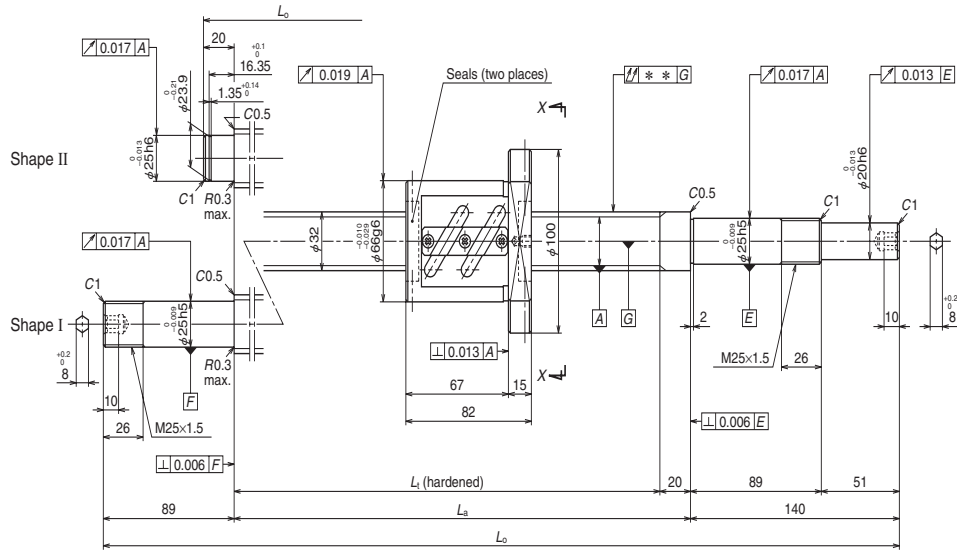

Nut model: ZFT

NSK

Screw shaft ø32

Lead 8

Unit: mm

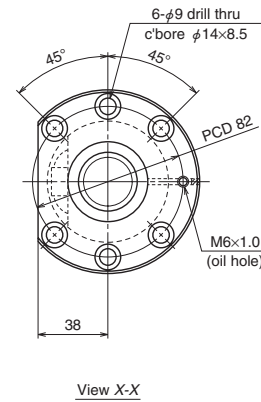

Ball screw specifications		
Shaft dia. x Lead / Direction of turn	32 × 8 / Right	
Preload / Ball recirculation	Z-preload / Return tube	
Ball dia. / Ball circle dia.	4.762 / 32.5	
Screw shaft root diameter	27.5	
Effective turns of balls	2.5 × 1	
Accuracy grade / Preload	C5 / Z	
Basic load rating (N)	Dynamic C _s	17 500
	Static C _{0a}	41 000
Preload (N)	1 320	
Dynamic friction torque, median, (N·cm)	31.0	
Spacer ball	None	
Factory-packed grease	Refer to NOTES 2.	
Internal spatial volume of nut (cm ³)	13	
Standard volume of grease replenishing (cm ³)	6.5	

Recommended support unit

For drive side, for opposite to drive side (Fixed)

WBK25DF-31H (round)

Unit: mm

Ball screw No.	Stroke		Screw shaft length		
	Nominal	Maximum	L _t	L _a	L _o
W3203SA-5Z-C5Z8	250	290	380	400	560
W3205SA-5Z-C5Z8	450	490	580	600	760
W3207SA-5Z-C5Z8	650	690	780	800	1 029
W3209SA-5Z-C5Z8	850	890	980	1 000	1 229
W3214SA-5Z-C5Z8	1 350	1 390	1 480	1 500	1 729

Notes: 1. We recommend NSK support unit. See page B389 for details.

2. Only rust preventive agent is applied at time of delivery. Please apply lubricant (oil or grease) before use. See page D13 for details.

3. Contact NSK if the permissible rotational speed is to be exceeded.

Left side shaft end	Lead accuracy			Shaft run-out **	Mass (kg)	Permissible rotational speed N (min ⁻¹)	
	T	e _p	v _u			Supporting condition	
						Fixed - Simple support	Fixed - Fixed
II	-0.009	0.025	0.020	0.050	4.7	2 180	—
II	-0.014	0.030	0.023	0.060	5.8	2 180	—
I	-0.019	0.035	0.025	0.090	7.2	2 180	2 180
I	-0.024	0.040	0.027	0.090	8.3	2 180	2 180
I	-0.036	0.054	0.035	0.150	11.1	1 960	2 180

Finished shaft end SA Type

(Fine lead)

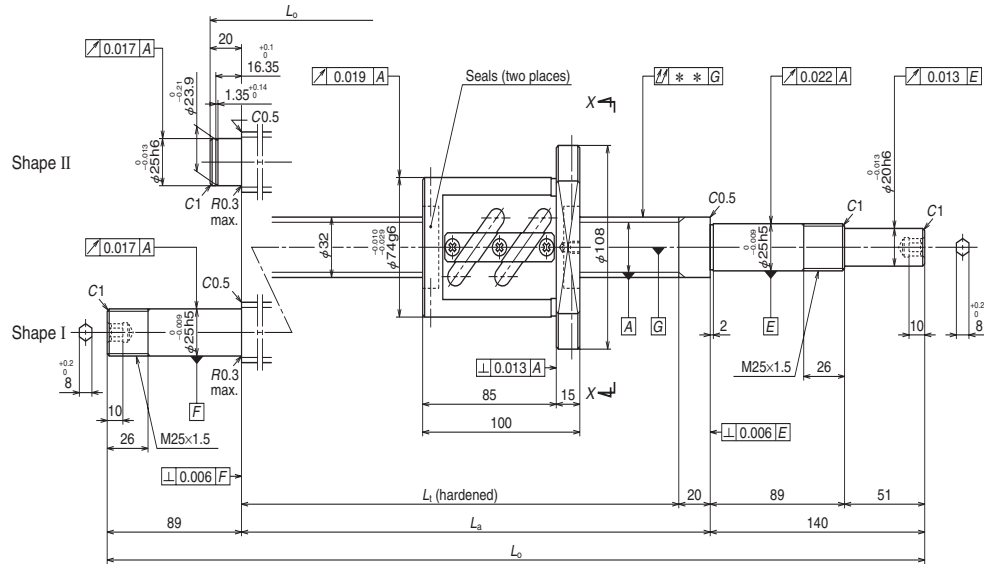

Nut model: ZFT

NSK

Screw shaft ø32

Lead 10

Unit: mm

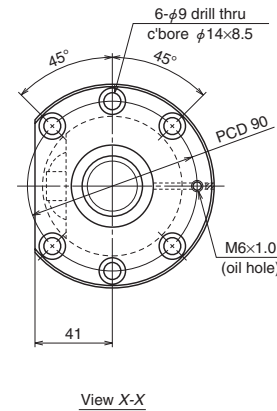

Ball screw specifications		
Shaft dia. x Lead / Direction of turn	32 x 10 / Right	
Preload / Ball recirculation	Z-preload / Return tube	
Ball dia. / Ball circle dia.	6.35 / 33	
Screw shaft root diameter	26.4	
Effective turns of balls	2.5 x 1	
Accuracy grade / Preload	C5 / Z	
Basic load rating (N)	Dynamic C_d	25 500
	Static C_0	54 000
Preload (N)	1 960	
Dynamic friction torque, median, (N·cm)	54.0	
Spacer ball	None	
Factory-packed grease	Refer to NOTES 2.	
Internal spatial volume of nut (cm ³)	22	
Standard volume of grease replenishing (cm ³)	11	

Recommended support unit

For drive side, for opposite to drive side (Fixed)
WBK25DF-31H (round)

Unit: mm

Ball screw No.	Stroke		Screw shaft length		
	Nominal	Maximum	L_t	L_a	L_o
W3203SA-6Z-C5Z10	250	272	380	400	560
W3204SA-3Z-C5Z10	350	372	480	500	660
W3205SA-6Z-C5Z10	450	472	580	600	760
W3206SA-3Z-C5Z10	550	572	680	700	929
W3207SA-6Z-C5Z10	650	672	780	800	1 029
W3209SA-6Z-C5Z10	850	872	980	1 000	1 229
W3211SA-5Z-C5Z10	1 050	1 072	1 180	1 200	1 429
W3214SA-6Z-C5Z10	1 350	1 372	1 480	1 500	1 729
W3217SA-1Z-C5Z10	1 650	1 672	1 780	1 800	2 029

- Notes: 1. We recommend NSK support unit. See page B389 for details.
 2. Only rust preventive agent is applied at time of delivery. Please apply lubricant (oil or grease) before use. See page D13 for details.
 3. Contact NSK if the permissible rotational speed is to be exceeded.

Left side shaft end	Lead accuracy			Shaft run-out **	Mass (kg)	Permissible rotational speed N (min ⁻¹)	
	T	e_p	v_u			Supporting condition	
						Fixed - Simple support	Fixed - Fixed
II	-0.009	0.025	0.020	0.050	5.5	2 180	—
II	-0.012	0.027	0.020	0.060	6.0	2 180	—
II	-0.014	0.030	0.023	0.060	6.6	2 180	—
I	-0.016	0.035	0.025	0.075	7.4	2 180	2 180
I	-0.019	0.035	0.025	0.090	7.9	2 180	2 180
I	-0.024	0.040	0.027	0.090	9.0	2 180	2 180
I	-0.028	0.046	0.030	0.120	10.1	2 180	2 180
I	-0.036	0.054	0.035	0.150	11.7	1 920	2 180
I	-0.043	0.065	0.040	0.200	13.3	1 310	1 810

Finished shaft end SA Type

(Fine lead)

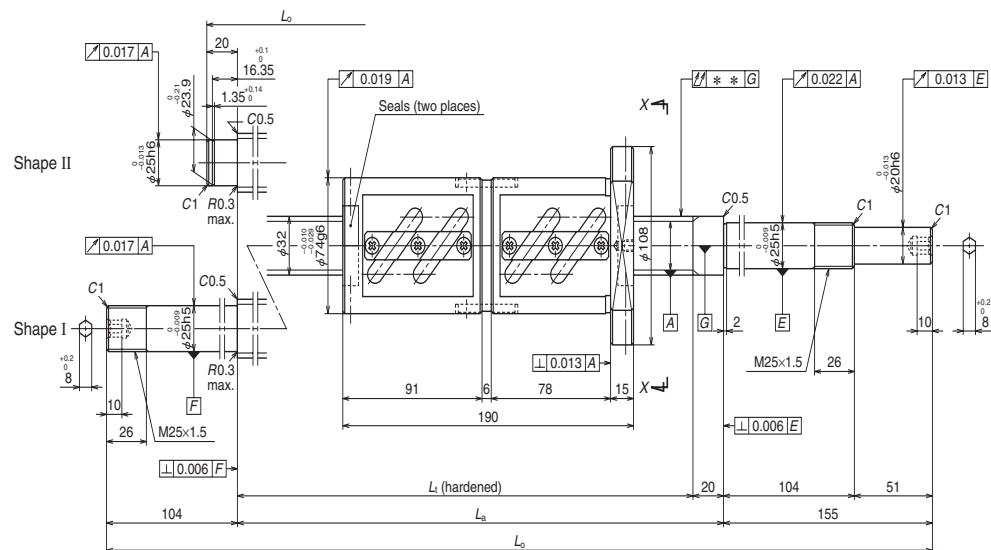

Nut model: DFT

NSK

Screw shaft ø32

Lead 10

Unit: mm

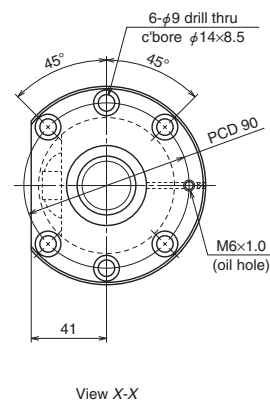

Ball screw specifications

Shaft dia. x Lead / Direction of turn	32 x 10 / Right	
Preload / Ball recirculation	D-preload / Return tube	
Ball dia. / Ball circle dia.	6.35 / 33	
Screw shaft root diameter	26.4	
Effective turns of balls	2.5 x 2	
Accuracy grade / Preload	C5 / Z	
Basic load rating (N)	Dynamic C_d	46 300
	Static C_0	108 000
Preload (N)	3 230	
Dynamic friction torque, median, (N·cm)	83.0	
Spacer ball	None	
Factory-packed grease	Refer to NOTES 2.	
Internal spatial volume of nut (cm ³)	44	
Standard volume of grease replenishing (cm ³)	22	

Recommended support unit

For drive side, for opposite to drive side (Fixed)

WBK25DFD-31H (round)

Unit: mm

Ball screw No.	Stroke		Screw shaft length		
	Nominal	Maximum	L_t	L_a	L_o
W3203SA-7D-C5Z10	150	182	380	400	575
W3204SA-4D-C5Z10	250	282	480	500	675
W3205SA-7D-C5Z10	350	382	580	600	775
W3206SA-4D-C5Z10	450	482	680	700	959
W3207SA-7D-C5Z10	550	582	780	800	1 059
W3209SA-7D-C5Z10	750	782	980	1 000	1 259
W3211SA-6D-C5Z10	950	982	1 180	1 200	1 459
W3214SA-7D-C5Z10	1 250	1 282	1 480	1 500	1 759
W3217SA-2D-C5Z10	1 550	1 582	1 780	1 800	2 059

Left side shaft end	Lead accuracy			Shaft run-out **	Mass (kg)	Permissible rotational speed N (min ⁻¹)	
	T	e_p	v_u			Supporting condition	
						Fixed - Simple support	Fixed - Fixed
II	-0.009	0.025	0.020	0.050	7.5	2 180	—
II	-0.012	0.027	0.020	0.060	8.1	2 180	—
II	-0.014	0.030	0.023	0.060	8.6	2 180	—
I	-0.016	0.035	0.025	0.075	9.5	2 180	2 180
I	-0.019	0.035	0.025	0.090	10.0	2 180	2 180
I	-0.024	0.040	0.027	0.120	11.1	2 180	2 180
I	-0.028	0.046	0.030	0.120	12.2	2 180	2 180
I	-0.036	0.054	0.035	0.150	13.8	2 050	2 180
I	-0.043	0.065	0.040	0.200	15.4	1 380	1 910

Notes: 1. We recommend NSK support unit. See page B389 for details.

2. Only rust preventive agent is applied at time of delivery. Please apply lubricant (oil or grease) before use. See page D13 for details.

3. Contact NSK if the permissible rotational speed is to be exceeded.

Finished shaft end SA Type

(Fine lead)

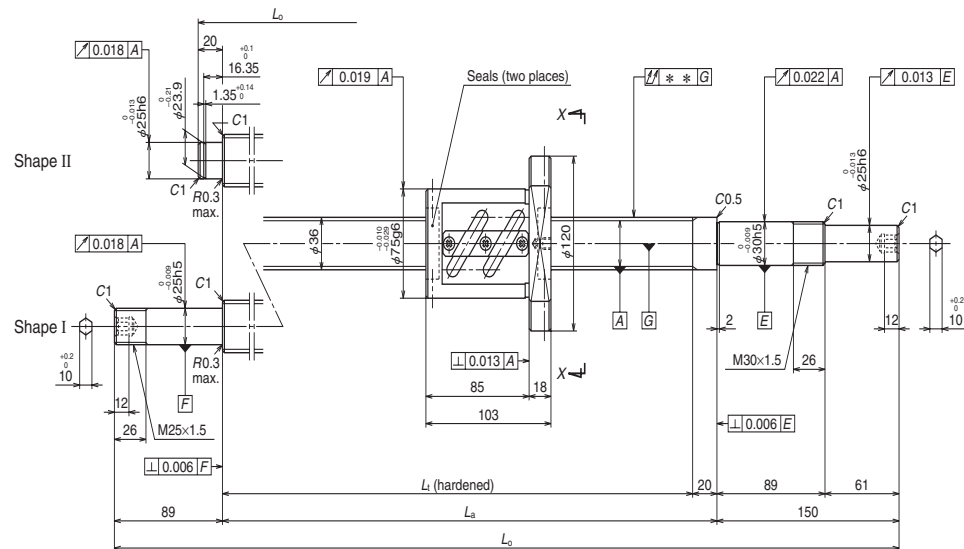

Nut model: ZFT

NSK

Screw shaft ø36

Lead 10

Unit: mm

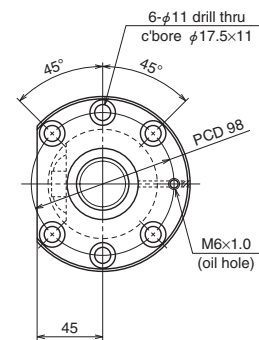

View X-X

Ball screw specifications

Shaft dia. x Lead / Direction of turn	36 × 10 / Right	
Preload / Ball recirculation	Z-preload / Return tube	
Ball dia. / Ball circle dia.	6.35 / 37	
Screw shaft root diameter	30.4	
Effective turns of balls	2.5 × 1	
Accuracy grade / Preload	C5 / Z	
Basic load rating (N)	Dynamic C_d	27 200
	Static C_{0a}	61 300
Preload (N)	2 060	
Dynamic friction torque, median, (N·cm)	59.0	
Spacer ball	None	
Factory-packed grease	Refer to NOTES 2.	
Internal spatial volume of nut (cm ³)	32	
Standard volume of grease replenishing (cm ³)	16	

Recommended support unit

For drive side (Fixed)	For opposite to drive side (Simple)
WBK30DF-31H (round)	WBK25DF-31H (round)

Unit: mm

Ball screw No.	Stroke		Screw shaft length		
	Nominal	Maximum	L_1	L_a	L_o
W3604SA-1Z-C5Z10	350	370	480	500	670
W3606SA-1Z-C5Z10	550	570	680	700	870
W3609SA-1Z-C5Z10	850	870	980	1 000	1 239
W3613SA-1Z-C5Z10	1 250	1 270	1 380	1 400	1 639
W3617SA-1Z-C5Z10	1 650	1 670	1 780	1 800	2 039

Notes: 1. We recommend NSK support unit. See page B389 for details.

2. Only rust preventive agent is applied at time of delivery. Please apply lubricant (oil or grease) before use. See page D13 for details.

3. Contact NSK if the permissible rotational speed is to be exceeded.

Left side shaft end	Lead accuracy			Shaft run-out **	Mass (kg)	Permissible rotational speed N (min ⁻¹)	
	T	e_p	v_u			Supporting condition	
						Fixed - Simple support	Fixed - Fixed
II	-0.012	0.027	0.020	0.040	7.4	1 940	—
II	-0.016	0.035	0.025	0.050	8.8	1 940	—
I	-0.024	0.040	0.027	0.065	11.1	1 940	1 940
I	-0.033	0.054	0.035	0.100	13.9	1 940	1 940
I	-0.043	0.065	0.040	0.130	16.6	1 510	1 940

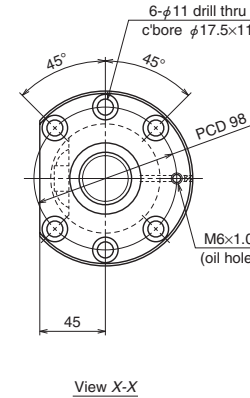
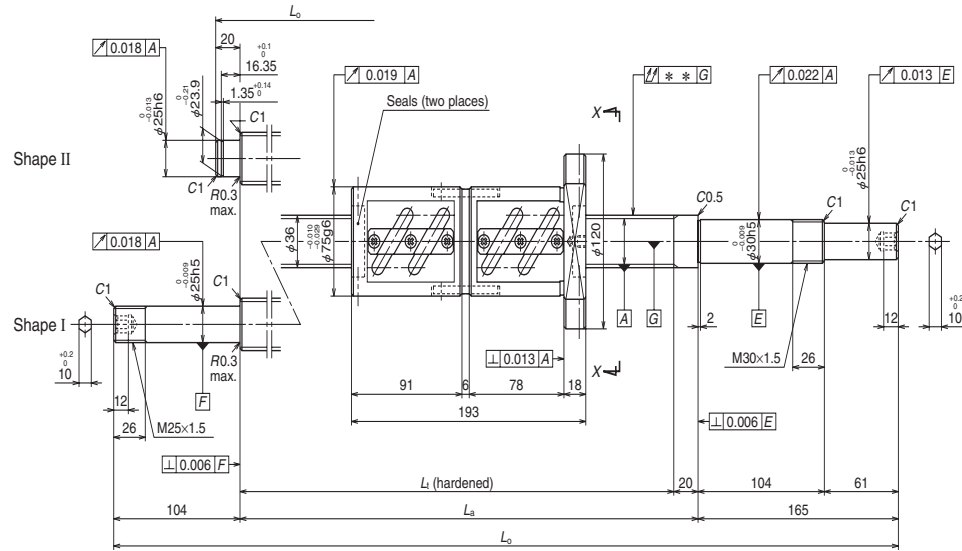

Ball screw specifications		
Shaft dia. x Lead / Direction of turn	36 × 10 / Right	
Preload / Ball recirculation	D-preload / Return tube	
Ball dia. / Ball circle dia.	6.35 / 37	
Screw shaft root diameter	30.4	
Effective turns of balls	2.5 × 2	
Accuracy grade / Preload	C5 / Z	
Basic load rating (N)	Dynamic C _s	49 300
	Static C _{0a}	123 000
Preload (N)	3 430	
Dynamic friction torque, median, (N·cm)	93.0	
Spacer ball	None	
Factory-packed grease	Refer to NOTES 2.	
Internal spatial volume of nut (cm ³)	64	
Standard volume of grease replenishing (cm ³)	27	

Recommended support unit

For drive side (Fixed)	For opposite to drive side (Fixed)
WBK30DFD-31H (round)	WBK25DFD-31H (round)

Ball screw No.	Stroke		Screw shaft length		
	Nominal	Maximum	L _t	L _a	L _o
W3604SA-2D-C5Z10	250	280	480	500	685
W3606SA-2D-C5Z10	450	480	680	700	885
W3609SA-2D-C5Z10	750	780	980	1 000	1 269
W3613SA-2D-C5Z10	1 150	1 180	1 380	1 400	1 669
W3617SA-2D-C5Z10	1 550	1 580	1 780	1 800	2 069

- Notes: 1. We recommend NSK support unit. See page B389 for details.
 2. Only rust preventive agent is applied at time of delivery. Please apply lubricant (oil or grease) before use. See page D13 for details.
 3. Contact NSK if the permissible rotational speed is to be exceeded.

Left side shaft end	Lead accuracy			Shaft run-out **	Mass (kg)	Permissible rotational speed N (min ⁻¹)	
	T	e _p	v _u			Supporting condition	
						Fixed - Simple support	Fixed - Fixed
II	-0.012	0.027	0.020	0.040	9.3	1 940	—
II	-0.016	0.035	0.025	0.050	10.7	1 940	—
I	-0.024	0.040	0.027	0.080	13.1	1 940	1 940
I	-0.033	0.054	0.035	0.100	15.9	1 940	1 940
I	-0.043	0.065	0.040	0.130	18.6	1 600	1 940

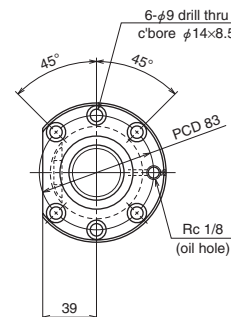
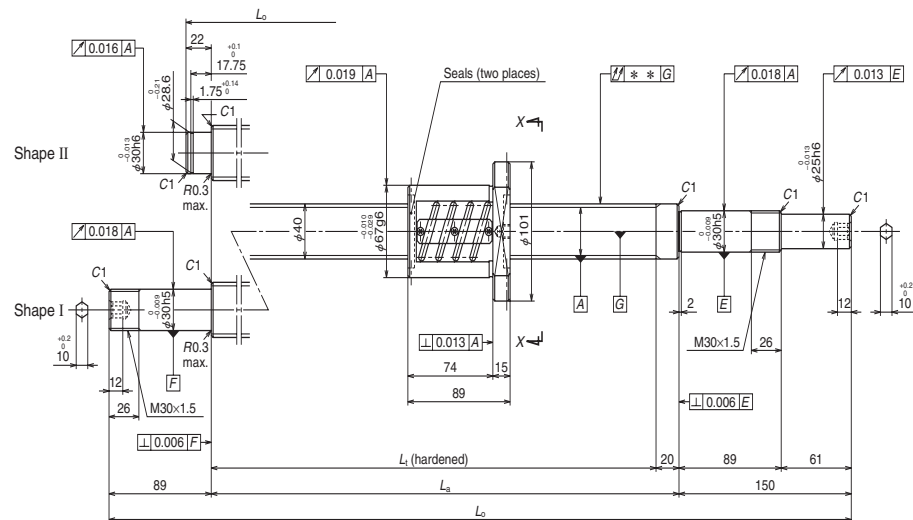

View X-X

Ball screw specifications

Shaft dia. x Lead / Direction of turn	40 x 5 / Right	
Preload / Ball recirculation	Z-preload / Return tube	
Ball dia. / Ball circle dia.	3.175 / 40.5	
Screw shaft root diameter	37.2	
Effective turns of balls	2.5 x 2	
Accuracy grade / Preload	C5 / Z	
Basic load rating (N)	Dynamic C_d	20 200
	Static C_0	70 600
Preload (N)	1 420	
Dynamic friction torque, median, (N·cm)	29.5	
Spacer ball	None	
Factory-packed grease	Refer to NOTES 2.	
Internal spatial volume of nut (cm ³)	14	
Standard volume of grease replenishing (cm ³)	7	

Recommended support unit

For drive side, for opposite to drive side (Fixed)

WBK30DF-31H (round)

Ball screw No.	Stroke		Screw shaft length		
	Nominal	Maximum	L_t	L_a	L_o
W4003SA-1Z-C5Z5	250	284	380	400	572
W4005SA-1Z-C5Z5	450	484	580	600	772
W4007SA-1Z-C5Z5	650	684	780	800	1 039
W4009SA-1Z-C5Z5	850	884	980	1 000	1 239
W4011SA-1Z-C5Z5	1 050	1 084	1 180	1 200	1 439
W4015SA-1Z-C5Z5	1 450	1 484	1 580	1 600	1 839

- Notes: 1. We recommend NSK support unit. See page B389 for details.
 2. **Only rust preventive agent is applied at time of delivery. Please apply lubricant (oil or grease) before use.** See page D13 for details.
 3. Contact NSK if the permissible rotational speed is to be exceeded.

Left side shaft end	Lead accuracy			Shaft run-out **	Mass (kg)	Permissible rotational speed N (min ⁻¹)	
	T	e_p	v_u			Supporting condition	
						Fixed - Simple support	Fixed - Fixed
II	-0.009	0.025	0.020	0.035	6.3	1 750	—
II	-0.014	0.030	0.023	0.040	8.1	1 750	—
I	-0.019	0.035	0.025	0.065	10.3	1 750	1 750
I	-0.024	0.040	0.027	0.065	12.2	1 750	1 750
I	-0.028	0.046	0.030	0.080	14.0	1 750	1 750
I	-0.038	0.054	0.035	0.100	17.7	1 750	1 750

Finished shaft end SA Type

(Fine lead)

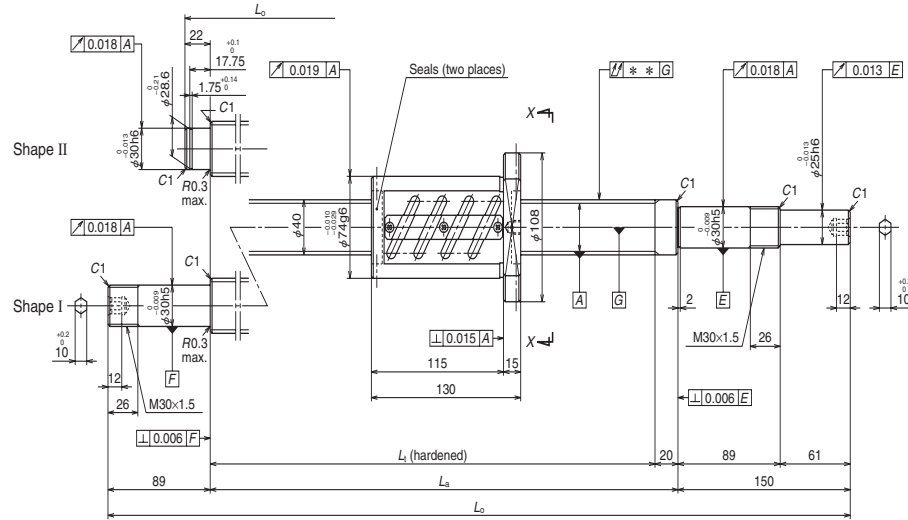

Nut model: ZFT

NSK

Screw shaft ø40

Lead 8

Unit: mm

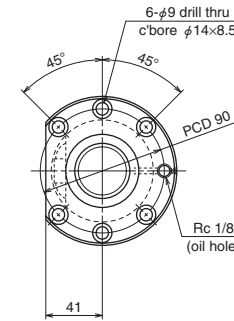

Ball screw specifications

Shaft dia. x Lead / Direction of turn	40 x 8 / Right	
Preload / Ball recirculation	Z-preload / Return tube	
Ball dia. / Ball circle dia.	4.762 / 40.5	
Screw shaft root diameter	35.5	
Effective turns of balls	2.5 x 2	
Accuracy grade / Preload	C5 / Z	
Basic load rating (N)	Dynamic C_d	34 900
	Static C_{0a}	103 000
Preload (N)	2 450	
Dynamic friction torque, median, (N·cm)	64.0	
Spacer ball	None	
Factory-packed grease	Refer to NOTES 2.	
Internal spatial volume of nut (cm ³)	27	
Standard volume of grease replenishing (cm ³)	14	

Recommended support unit

For drive side, for opposite to drive side (Fixed)

WBK30DF-31H (round)

Unit: mm

Ball screw No.	Stroke		Screw shaft length		
	Nominal	Maximum	L_t	L_a	L_o
W4003SA-2Z-C5Z8	200	243	380	400	572
W4005SA-2Z-C5Z8	400	443	580	600	772
W4007SA-2Z-C5Z8	600	643	780	800	1 039
W4009SA-2Z-C5Z8	800	843	980	1 000	1 239
W4011SA-2Z-C5Z8	1 000	1 043	1 180	1 200	1 439
W4015SA-2Z-C5Z8	1 400	1 443	1 580	1 600	1 839

Notes: 1. We recommend NSK support unit. See page B389 for details.

2. Only rust preventive agent is applied at time of delivery. Please apply lubricant (oil or grease) before use. See page D13 for details.

3. Contact NSK if the permissible rotational speed is to be exceeded.

Left side shaft end	Lead accuracy			Shaft run-out **	Mass (kg)	Permissible rotational speed N (min ⁻¹)	
	T	e_p	v_u			Supporting condition	
						Fixed - Simple support	Fixed - Fixed
II	-0.009	0.025	0.020	0.035	7.4	1 750	—
II	-0.014	0.030	0.023	0.040	9.2	1 750	—
I	-0.019	0.035	0.025	0.065	11.3	1 750	1 750
I	-0.024	0.040	0.027	0.065	13.1	1 750	1 750
I	-0.028	0.046	0.030	0.080	14.9	1 750	1 750
I	-0.038	0.054	0.035	0.100	18.5	1 750	1 750

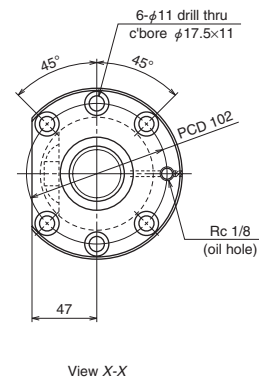
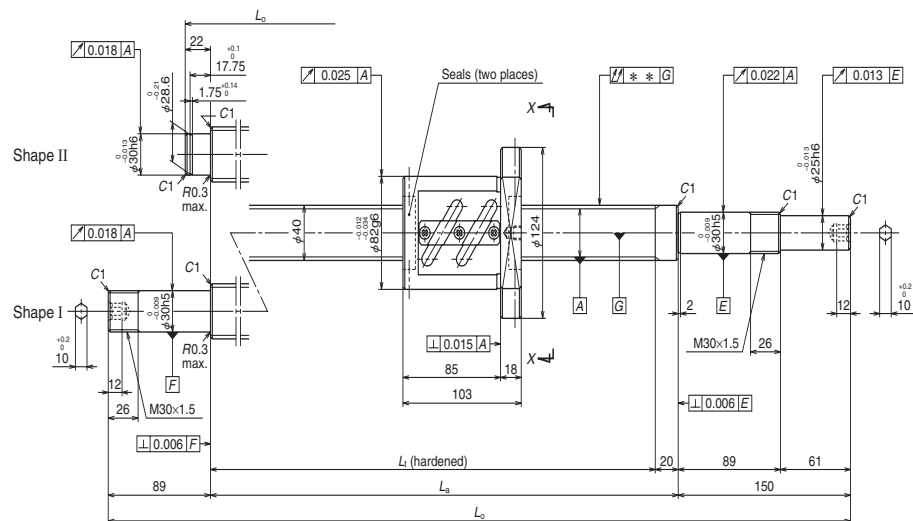

Ball screw specifications		
Shaft dia. x Lead / Direction of turn	40 × 10 / Right	
Preload / Ball recirculation	Z-preload / Return tube	
Ball dia. / Ball circle dia.	6.35 / 41	
Screw shaft root diameter	34.4	
Effective turns of balls	2.5 × 1	
Accuracy grade / Preload	C5 / Z	
Basic load rating (N)	Dynamic C _s	28 600
	Static C _{0a}	68 600
Preload (N)	2 160	
Dynamic friction torque, median, (N·cm)	64.0	
Spacer ball	None	
Factory-packed grease	Refer to NOTES 2.	
Internal spatial volume of nut (cm ³)	30	
Standard volume of grease replenishing (cm ³)	15	

Recommended support unit

For drive side, for opposite to drive side (Fixed)
WBK30DF-31H (round)

Ball screw No.	Stroke		Screw shaft length		
	Nominal	Maximum	L _t	L _a	L _o
W4004SA-1Z-C5Z10	350	370	480	500	672
W4005SA-3Z-C5Z10	450	470	580	600	772
W4006SA-1Z-C5Z10	550	570	680	700	872
W4007SA-3Z-C5Z10	650	670	780	800	1 039
W4009SA-3Z-C5Z10	850	870	980	1 000	1 239
W4011SA-3Z-C5Z10	1 050	1 070	1 180	1 200	1 439
W4013SA-1Z-C5Z10	1 250	1 270	1 380	1 400	1 639
W4015SA-3Z-C5Z10	1 450	1 470	1 580	1 600	1 839
W4017SA-1Z-C5Z10	1 650	1 670	1 780	1 800	2 039
W4023SA-1Z-C5Z10	2 250	2 270	2 380	2 400	2 639

Left side shaft end	Lead accuracy			Shaft run-out **	Mass (kg)	Permissible rotational speed N (min ⁻¹)	
	T	e _p	v _u			Supporting condition	
						Fixed - Simple support	Fixed - Fixed
II	-0.012	0.027	0.020	0.040	8.7	1 750	—
II	-0.014	0.030	0.023	0.040	9.6	1 750	—
II	-0.016	0.035	0.025	0.050	10.4	1 750	—
I	-0.019	0.035	0.025	0.065	11.7	1 750	1 750
I	-0.024	0.040	0.027	0.065	13.4	1 750	1 750
I	-0.028	0.046	0.030	0.080	15.1	1 750	1 750
I	-0.033	0.054	0.035	0.100	16.9	1 750	1 750
I	-0.038	0.054	0.035	0.100	18.6	1 750	1 750
I	-0.043	0.065	0.040	0.130	20.3	1 710	1 750
I	-0.057	0.077	0.046	0.170	25.5	940	1 320

- Notes: 1. We recommend NSK support unit. See page B389 for details.
 2. Only rust preventive agent is applied at time of delivery. Please apply lubricant (oil or grease) before use. See page D13 for details.
 3. Contact NSK if the permissible rotational speed is to be exceeded.

Finished shaft end SA Type

(Fine lead)

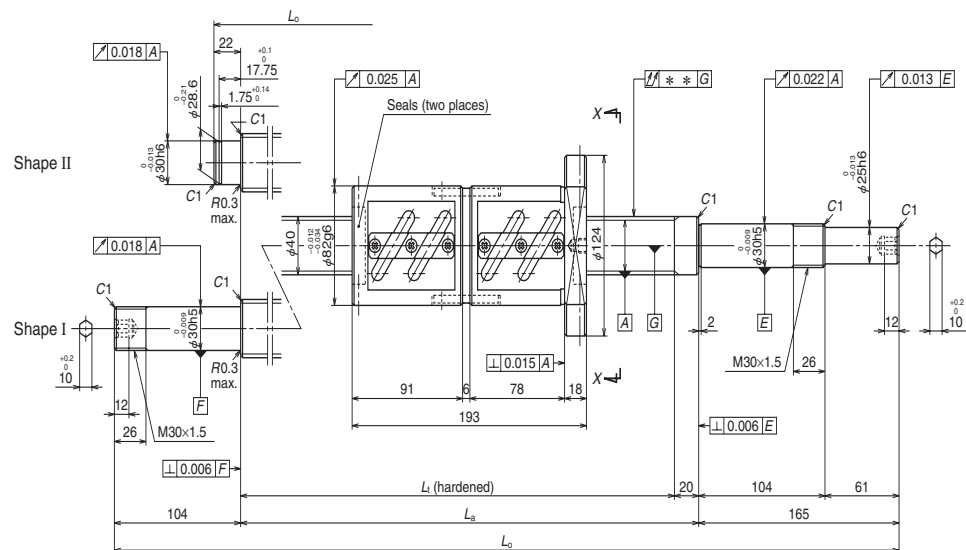

Nut model: DFT

NSK

Screw shaft $\phi 40$

Lead 10

Unit: mm

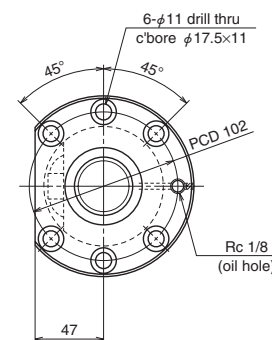

View X-X

Ball screw specifications

Shaft dia. x Lead / Direction of turn	40 x 10 / Right	
Preload / Ball recirculation	D-preload / Return tube	
Ball dia. / Ball circle dia.	6.35 / 41	
Screw shaft root diameter	34.4	
Effective turns of balls	2.5 x 2	
Accuracy grade / Preload	C5 / Z	
Basic load rating (N)	Dynamic C_d	52 000
	Static C_{0a}	137 000
Preload (N)	3 630	
Dynamic friction torque, median, (N·cm)	108	
Spacer ball	None	
Factory-packed grease	Refer to NOTES 2.	
Internal spatial volume of nut (cm ³)	59	
Standard volume of grease replenishing (cm ³)	30	

Recommended support unit

For drive side, for opposite to drive side (Fixed)

WBK30DFD-31H (round)

Unit: mm

Ball screw No.	Stroke		Screw shaft length		
	Nominal	Maximum	L_t	L_a	L_o
W4004SA-2D-C5Z10	250	280	480	500	687
W4005SA-4D-C5Z10	350	380	580	600	787
W4006SA-2D-C5Z10	450	480	680	700	887
W4007SA-4D-C5Z10	550	580	780	800	1 069
W4009SA-4D-C5Z10	750	780	980	1 000	1 269
W4011SA-4D-C5Z10	950	980	1 180	1 200	1 469
W4013SA-2D-C5Z10	1 150	1 180	1 380	1 400	1 669
W4015SA-4D-C5Z10	1 350	1 380	1 580	1 600	1 869
W4017SA-2D-C5Z10	1 550	1 580	1 780	1 800	2 069
W4023SA-2D-C5Z10	2 150	2 180	2 380	2 400	2 669

Notes: 1. We recommend NSK support unit. See page B389 for details.

2. **Only rust preventive agent is applied at time of delivery. Please apply lubricant (oil or grease) before use.** See page D13 for details.

3. Contact NSK if the permissible rotational speed is to be exceeded.

Left side shaft end	Lead accuracy			Shaft run-out **	Mass (kg)	Permissible rotational speed N (min ⁻¹)	
	T	e_p	v_u			Supporting condition	
						Fixed - Simple support	Fixed - Fixed
II	-0.012	0.027	0.020	0.040	11.0	1 750	—
II	-0.014	0.030	0.023	0.040	11.9	1 750	—
II	-0.016	0.035	0.025	0.050	12.7	1 750	—
I	-0.019	0.035	0.025	0.065	14.1	1 750	1 750
I	-0.024	0.040	0.027	0.080	15.8	1 750	1 750
I	-0.028	0.046	0.030	0.080	17.5	1 750	1 750
I	-0.033	0.054	0.035	0.100	19.3	1 750	1 750
I	-0.038	0.054	0.035	0.100	21.0	1 750	1 750
I	-0.043	0.065	0.040	0.130	22.7	1 750	1 750
I	-0.057	0.077	0.046	0.170	27.9	980	1 370

Finished shaft end SA Type

(Fine lead)

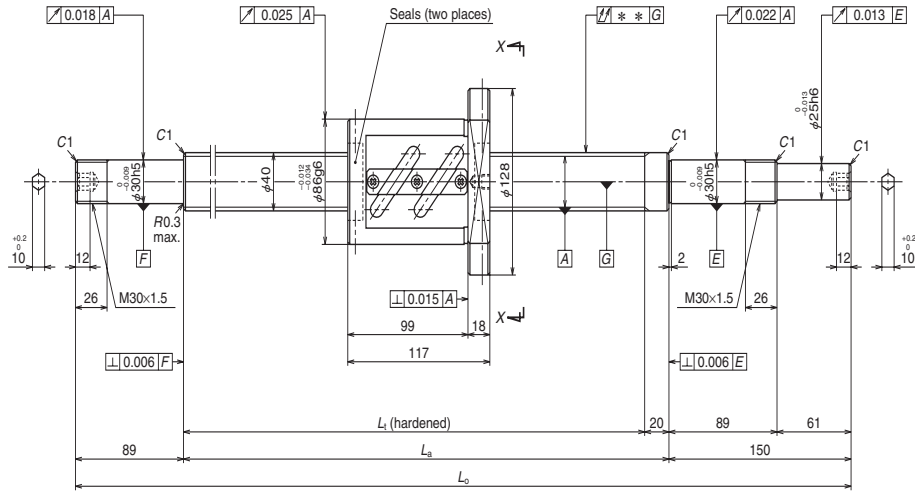

Nut model: ZFT

NSK

Screw shaft $\phi 40$

Lead 12

Unit: mm

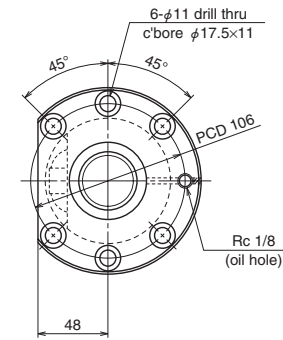

View X-X

Ball screw specifications

Shaft dia. x Lead / Direction of turn	40 x 12 / Right	
Preload / Ball recirculation	Z-preload / Return tube	
Ball dia. / Ball circle dia.	7.144 / 41.5	
Screw shaft root diameter	34.1	
Effective turns of balls	2.5 x 1	
Accuracy grade / Preload	C5 / Z	
Basic load rating (N)	Dynamic C_d	33 600
	Static C_{0a}	77 500
Preload (N)	2 550	
Dynamic friction torque, median, (N·cm)	83.0	
Spacer ball	None	
Factory-packed grease	Refer to NOTES 2.	
Internal spatial volume of nut (cm ³)	33	
Standard volume of grease replenishing (cm ³)	17	

Recommended support unit

For drive side, for opposite to drive side (Fixed)

WBK30DF-31H (round)

Unit: mm

Ball screw No.	Stroke		Screw shaft length		
	Nominal	Maximum	L_t	L_a	L_o
W4006SA-3Z-C5Z12	500	556	680	700	939
W4009SA-5Z-C5Z12	800	856	980	1 000	1 239
W4013SA-3Z-C5Z12	1 200	1 256	1 380	1 400	1 639
W4017SA-3Z-C5Z12	1 600	1 656	1 780	1 800	2 039
W4024SA-1Z-C5Z12	2 300	2 356	2 480	2 500	2 739

Lead accuracy			Shaft run-out ** μ	Mass (kg)	Permissible rotational speed N (min ⁻¹)	
T	e_p	v_u			Supporting condition	
					Fixed - Simple support	Fixed - Fixed
-0.016	0.035	0.025	0.050	11.6	1 750	1 750
-0.024	0.040	0.027	0.065	14.2	1 750	1 750
-0.033	0.054	0.035	0.100	17.7	1 750	1 750
-0.043	0.065	0.040	0.130	21.2	1 710	1 750
-0.060	0.077	0.046	0.170	27.2	870	1 210

Notes: 1. We recommend NSK support unit. See page B389 for details.

2. **Only rust preventive agent is applied at time of delivery. Please apply lubricant (oil or grease) before use.** See page D13 for details.

3. Contact NSK if the permissible rotational speed is to be exceeded.

Finished shaft end SA Type

(Fine lead)

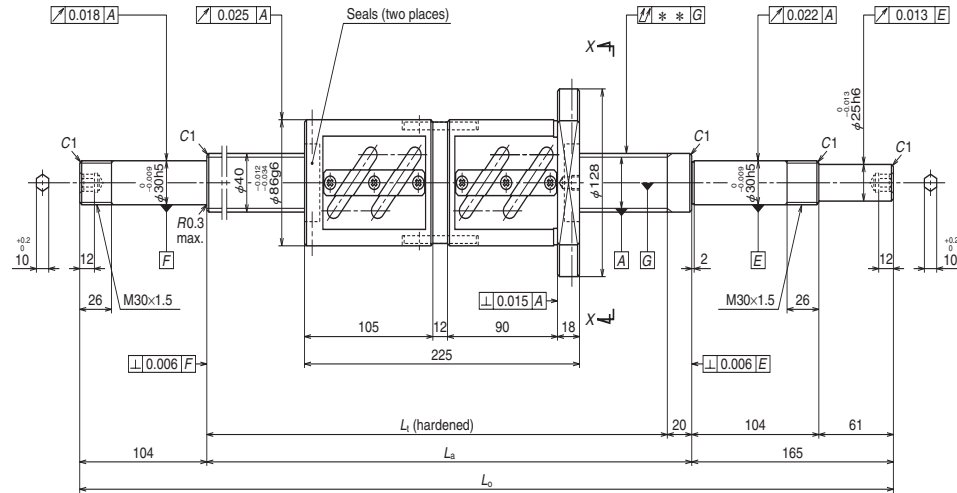

Nut model: DFT

NSK

Screw shaft $\phi 40$

Lead 12

Unit: mm

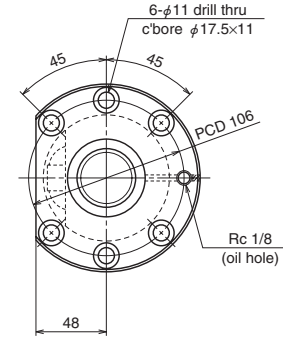

View X-X

Ball screw specifications

Shaft dia. x Lead / Direction of turn	40 x 12 / Right	
Preload / Ball recirculation	D-preload / Return tube	
Ball dia. / Ball circle dia.	7.144 / 41.5	
Screw shaft root diameter	34.1	
Effective turns of balls	2.5 x 2	
Accuracy grade / Preload	C5 / Z	
Basic load rating (N)	Dynamic C_d	61 000
	Static C_0	155 000
Preload (N)	4 310	
Dynamic friction torque, median, (N·cm)	137	
Spacer ball	None	
Factory-packed grease	Refer to NOTES 2.	
Internal spatial volume of nut (cm ³)	76	
Standard volume of grease replenishing (cm ³)	38	

Recommended support unit

For drive side, for opposite to drive side (Fixed)

WBK30DFD-31H (round)

Unit: mm

Ball screw No.	Stroke		Screw shaft length		
	Nominal	Maximum	L_t	L_a	L_o
W4006SA-4D-C5Z12	400	448	680	700	969
W4009SA-6D-C5Z12	700	748	980	1 000	1 269
W4013SA-4D-C5Z12	1 100	1 148	1 380	1 400	1 669
W4017SA-4D-C5Z12	1 500	1 548	1 780	1 800	2 069
W4024SA-2D-C5Z12	2 200	2 248	2 480	2 500	2 769

Notes: 1. We recommend NSK support unit. See page B389 for details.

2. **Only rust preventive agent is applied at time of delivery. Please apply lubricant (oil or grease) before use.** See page D13 for details.

3. Contact NSK if the permissible rotational speed is to be exceeded.

Lead accuracy			Shaft run-out **	Mass (kg)	Permissible rotational speed N (min ⁻¹)	
T	e_p	v_u			Supporting condition	
					Fixed - Simple support	Fixed - Fixed
-0.016	0.035	0.025	0.050	14.8	1 750	1 750
-0.024	0.040	0.027	0.080	17.4	1 750	1 750
-0.033	0.054	0.035	0.100	20.9	1 750	1 750
-0.043	0.065	0.040	0.130	24.3	1 750	1 750
-0.060	0.077	0.046	0.170	30.4	910	1 270

Finished shaft end SA Type

(Fine lead)

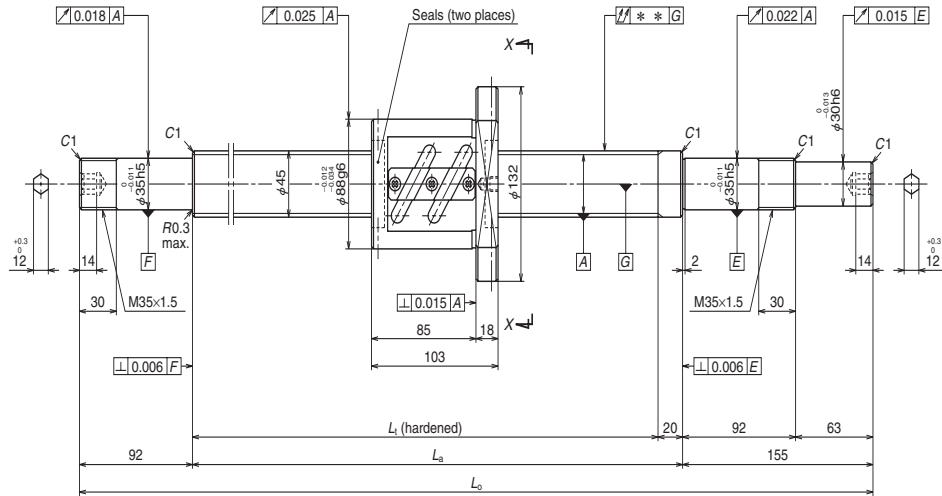

Nut model: ZFT

NSK

Screw shaft $\phi 45$

Lead 10

Unit: mm

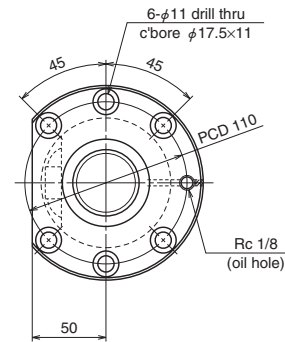

View X-X

Ball screw specifications

Shaft dia. x Lead / Direction of turn	45 x 10 / Right	
Preload / Ball recirculation	Z-preload / Return tube	
Ball dia. / Ball circle dia.	6.35 / 46	
Screw shaft root diameter	39.4	
Effective turns of balls	2.5 x 1	
Accuracy grade / Preload	C5 / Z	
Basic load rating (N)	Dynamic C_d	29 900
	Static C_0	77 300
Preload (N)	2 260	
Dynamic friction torque, median, (N-cm)	69.0	
Spacer ball	None	
Factory-packed grease	Refer to NOTES 2.	
Internal spatial volume of nut (cm ³)	33	
Standard volume of grease replenishing (cm ³)	17	

Recommended support unit

For drive side, for opposite to drive side (Fixed)

WBK35DF-31H (round)

Unit: mm

Ball screw No.	Stroke		Screw shaft length		
	Nominal	Maximum	L_t	L_a	L_o
W4506SA-1Z-C5Z10	550	568	680	700	947
W4509SA-1Z-C5Z10	850	868	980	1 000	1 247
W4513SA-1Z-C5Z10	1 250	1 268	1 380	1 400	1 647
W4517SA-1Z-C5Z10	1 650	1 668	1 780	1 800	2 047
W4524SA-1Z-C5Z10	2 350	2 368	2 480	2 500	2 747

Lead accuracy			Shaft run-out **	Mass (kg)	Permissible rotational speed N (min ⁻¹)	
T	e_p	v_u			Supporting condition	
					Fixed - Simple support	Fixed - Fixed
-0.016	0.035	0.025	0.050	13.4	1 550	1 550
-0.024	0.040	0.027	0.065	16.7	1 550	1 550
-0.033	0.054	0.035	0.100	21.2	1 550	1 550
-0.043	0.065	0.040	0.130	25.6	1 550	1 550
-0.060	0.077	0.046	0.170	33.4	990	1 390

- Notes: 1. We recommend NSK support unit. See page B389 for details.
 2. **Only rust preventive agent is applied at time of delivery. Please apply lubricant (oil or grease) before use.** See page D13 for details.
 3. Contact NSK if the permissible rotational speed is to be exceeded.

Finished shaft end SA Type

(Fine lead)

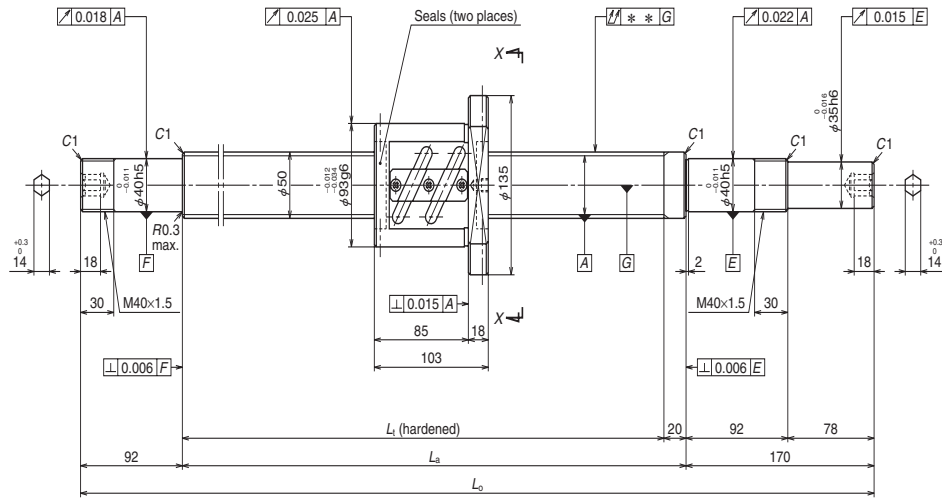

Nut model: ZFT

NSK

Screw shaft ø50

Lead 10

Unit: mm

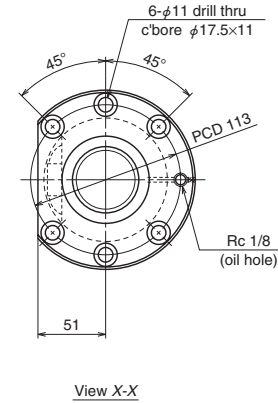

Ball screw specifications

Shaft dia. x Lead / Direction of turn	50 × 10 / Right	
Preload / Ball recirculation	Z-preload / Return tube	
Ball dia. / Ball circle dia.	6.35 / 51	
Screw shaft root diameter	44.4	
Effective turns of balls	2.5 × 1	
Accuracy grade / Preload	C5 / Z	
Basic load rating (N)	Dynamic C_d	31 800
	Static C_{0a}	87 400
Preload (N)	2 450	
Dynamic friction torque, median, (N·cm)	79.0	
Spacer ball	None	
Factory-packed grease	Refer to Notes 2.	
Internal spatial volume of nut (cm ³)	37	
Standard volume of grease replenishing (cm ³)	19	

Recommended support unit

For drive side, for opposite to drive side (Fixed)

WBK40DF-31H (round)

Unit: mm

Ball screw No.	Stroke		Screw shaft length		
	Nominal	Maximum	L_t	L_a	L_o
W5005SA-1Z-C5Z10	450	468	580	600	862
W5007SA-1Z-C5Z10	650	667	780	800	1 062
W5009SA-1Z-C5Z10	850	868	980	1 000	1 262
W5011SA-1Z-C5Z10	1 050	1 068	1 180	1 200	1 462
W5014SA-1Z-C5Z10	1 350	1 368	1 480	1 500	1 762
W5019SA-1Z-C5Z10	1 850	1 868	1 980	2 000	2 262
W5025SA-1Z-C5Z10	2 450	2 468	2 580	2 600	2 862

Lead accuracy			Shaft run-out **	Mass (kg)	Permissible rotational speed N (min ⁻¹)	
T	e_p	v_u			Supporting condition	
					Fixed - Simple support	Fixed - Fixed
-0.014	0.030	0.023	0.050	14.8	1 400	1 400
-0.019	0.035	0.025	0.065	17.6	1 400	1 400
-0.024	0.040	0.027	0.080	20.3	1 400	1 400
-0.028	0.046	0.030	0.080	23.1	1 400	1 400
-0.036	0.054	0.035	0.100	27.3	1 400	1 400
-0.048	0.065	0.040	0.130	34.2	1 400	1 400
-0.062	0.093	0.054	0.170	42.5	1 030	1 400

Notes: 1. We recommend NSK support unit. See page B389 for details.

2. Only rust preventive agent is applied at time of delivery. Please apply lubricant (oil or grease) before use. See page D13 for details.

3. Contact NSK if the permissible rotational speed is to be exceeded.

Finished shaft end SA Type

(Fine lead)

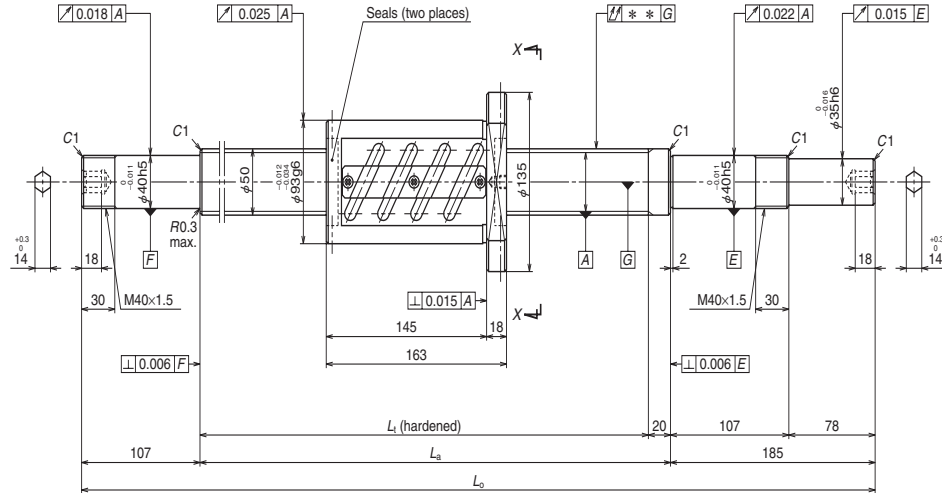

Nut model: ZFT

NSK

Screw shaft ø50

Lead 10

Unit: mm

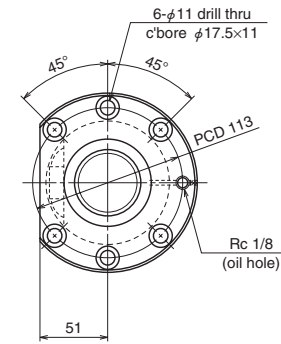

View X-X

Ball screw specifications

Shaft dia. x Lead / Direction of turn	50 × 10 / Right	
Preload / Ball recirculation	Z-preload / Return tube	
Ball dia. / Ball circle dia.	6.35 / 51	
Screw shaft root diameter	44.4	
Effective turns of balls	2.5 × 2	
Accuracy grade / Preload	C5 / Z	
Basic load rating (N)	Dynamic C_d	57 700
	Static C_{0a}	175 000
Preload (N)	4 020	
Dynamic friction torque, median, (N·cm)	137	
Spacer ball	None	
Factory-packed grease	Refer to NOTES 2.	
Internal spatial volume of nut (cm ³)	59	
Standard volume of grease replenishing (cm ³)	30	

Recommended support unit

For drive side, for opposite to drive side (Fixed)

WBK40DFD-31H (round)

Unit: mm

Ball screw No.	Stroke		Screw shaft length		
	Nominal	Maximum	L_1	L_a	L_o
W5005SA-2Z-C5Z10	350	408	580	600	892
W5007SA-2Z-C5Z10	550	608	780	800	1 092
W5009SA-2Z-C5Z10	750	808	980	1 000	1 292
W5011SA-2Z-C5Z10	950	1 008	1 180	1 200	1 492
W5014SA-2Z-C5Z10	1 250	1 308	1 480	1 500	1 792
W5019SA-2Z-C5Z10	1 750	1 808	1 980	2 000	2 292
W5025SA-2Z-C5Z10	2 350	2 408	2 580	2 600	2 892

Notes: 1. We recommend NSK support unit. See page B389 for details.

2. **Only rust preventive agent is applied at time of delivery. Please apply lubricant (oil or grease) before use.** See page D13 for details.

3. Contact NSK if the permissible rotational speed is to be exceeded.

Lead accuracy			Shaft run-out ** μ	Mass (kg)	Permissible rotational speed N (min ⁻¹)	
T	e_p	v_u			Supporting condition	
					Fixed - Simple support	Fixed - Fixed
-0.014	0.030	0.023	0.050	16.8	1 400	1 400
-0.019	0.035	0.025	0.065	19.6	1 400	1 400
-0.024	0.040	0.027	0.080	22.3	1 400	1 400
-0.028	0.046	0.030	0.080	25.1	1 400	1 400
-0.036	0.054	0.035	0.100	29.3	1 400	1 400
-0.048	0.065	0.040	0.130	36.2	1 400	1 400
-0.062	0.093	0.054	0.170	44.6	1 060	1 400

B-3-1.4 Finished Shaft End Ball Screws Made of Stainless Steel KA Type

1. Order of the dimension tables

The tables begin with the smallest shaft diameter ball screw, and proceeds to larger sizes. If ball screws have the same shaft diameter, those with smaller leads appear first. Page numbers of shaft diameter and lead combinations are shown in **Table 1**.

2. Dimension tables

The dimension tables show shapes/sizes as well as specification factors of each shaft diameter/lead combination. Tables also contain data as follows:

●Stroke

Nominal stroke : A reference for your use.

Maximum stroke: The stroke limit that the nut can move.

●Lead accuracy

Lead accuracy is C3 and C5 grades.

T : Travel compensation

e_p : Tolerance on specified travel

v_v : Travel variation

See "Technical Description: Lead Accuracy" (page B37) for details of the codes.

●Permissible rotational speed

$d \cdot n$: Limited by the relative peripheral speed between screw shaft and nut.

Critical speed: Limited by the natural frequency of a ball screw shaft. Critical speed depends on the supporting condition of screw shaft.

The lower of the two criteria, the $d \cdot n$ and critical speed, will determine the overall permissible rotational speed of the ball screw. For details, see "Technical Description: Permissible Rotational Speed" (page B47).

3. Material

A martensitic stainless steel is used. A special heat treatment technology provides the ball groove section with sufficient hardness which produces high load carrying capacity and durability.

4. Other

Seal of the ball screw, ball recirculating deflector, and end cap are made of synthetic resin. Consult NSK when using the ball screws under extreme environments or special environments, or using special lubricant or oil.

For special environments, see pages B70 and D2. See pages B67 and D13 for lubricants.

Note: For details of standard stock products, contact NSK.

Table 1 Combinations of screw shaft diameter and lead

Screw shaft diameter (mm)	Lead (mm)	
	1	2
6	B275	
8	B277	B279
10		B281
12		B285
15		
16		B295
20		

4	5	10	20
B283			
	B287	B289	
		B291	B293
			B297

Finished shaft end stainless steel product KA Type

(Fine lead)

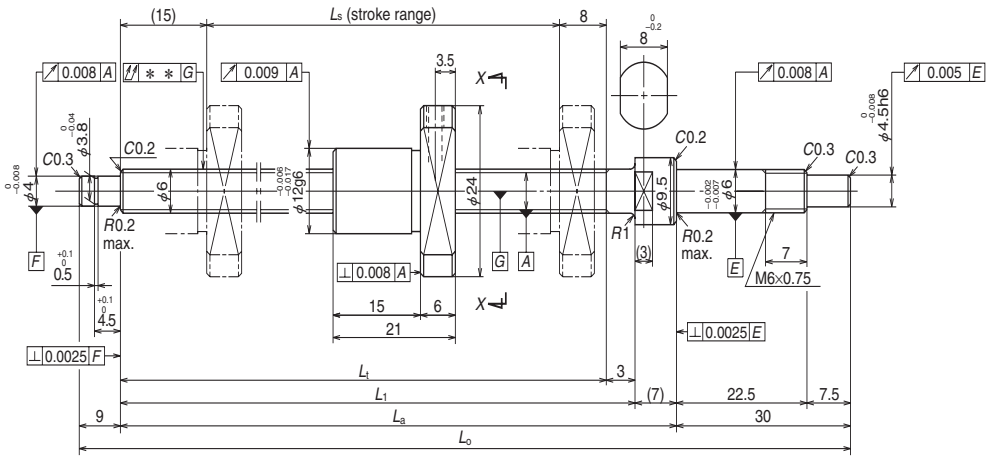

Nut model: MPFD

NSK

Screw shaft ø6

Lead 1

Unit: mm

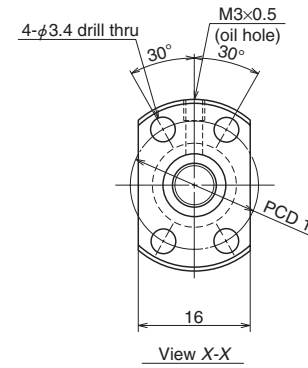

Ball screw specifications

Shaft dia. x Lead / Direction of turn	6 × 1 / Right	
Preload / Ball recirculation	P-preload / Deflector (bridge)	
Ball dia. / Ball circle dia.	0.800 / 6.2	
Screw shaft root diameter	5.2	
Effective turns of balls	1 × 3	
Accuracy grade / Preload	C3 / Z	
Basic load rating (N)	Dynamic C_a	470
	Static C_{0a}	680
Axial play	0	
Preload (N)	24.5	
Dynamic friction torque, (N-cm)	1.3 or less	
Spacer ball	None	
Factory-packed grease	Refer to Notes 1.	

Unit: mm

Ball screw No.	Stroke L_s		Thread length			
	Nominal	Maximum	L_1	L_1	L_a	L_o
W0601KA-3PY-C3Z1	100	102	125	128	135	174

Notes: **1. Only rust preventive agent is applied at time of delivery. Please apply lubricant (oil or grease) before use.**

See page D13 for details.
Use of NSK Clean Grease LG2 is recommended.

- Ball nut does not have seal.
- Contact NSK if the permissible rotational speed is to be exceeded.

Lead accuracy			Shaft run-out ** \uparrow	Mass (kg)	Permissible rotational speed N (min ⁻¹)	
T	e_p	v_u			Supporting condition	
					Fixed - Simple support	
0	0.010	0.008	0.025	0.06	3 000	

Finished shaft end stainless steel product KA Type

(Fine lead)

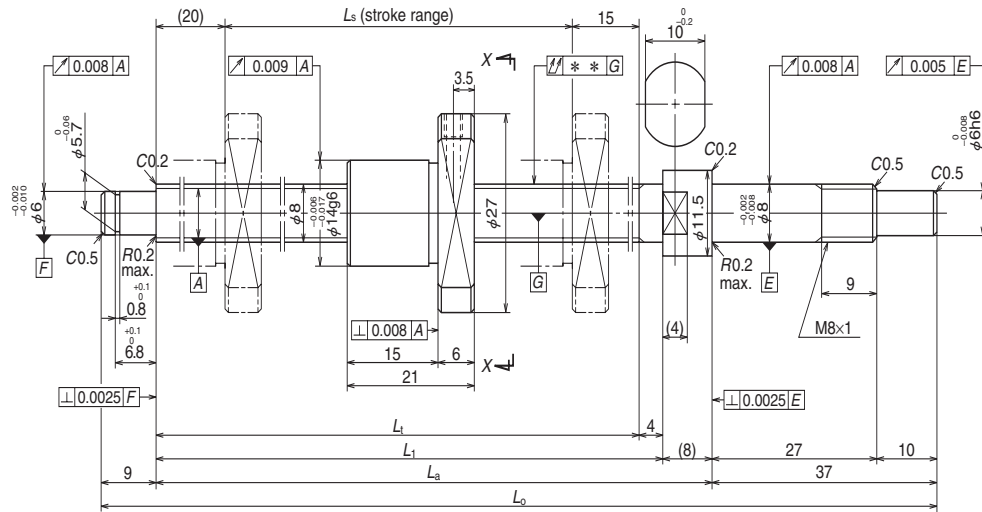

Nut model: MPFD

NSK

Screw shaft ø8

Lead 1

Unit: mm

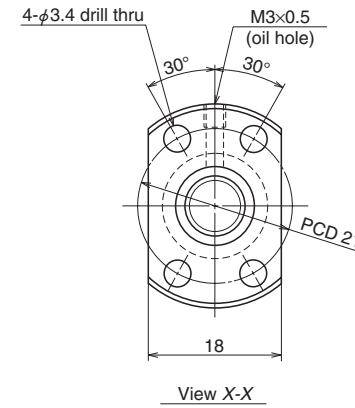

Ball screw specifications

Shaft dia. x Lead / Direction of turn	8 × 1 / Right	
Preload / Ball recirculation	P-preload / Deflector (bridge)	
Ball dia. / Ball circle dia.	0.800 / 8.2	
Screw shaft root diameter	7.2	
Effective turns of balls	1 × 3	
Accuracy grade / Preload	C3 / Z	
Basic load rating (N)	Dynamic C_a	545
	Static C_{0a}	955
Axial play	0	
Preload (N)	29.4	
Dynamic friction torque, (N-cm)	1.8 or less	
Spacer ball	None	
Factory-packed grease	Refer to Notes 1.	

Recommended support unit

For drive side (Fixed)	For opposite to drive side (Free)
WBK08-01C (square, clean)	WBK08S-01C (square, clean)
WBK08-11C (round, clean)	

Unit: mm

Ball screw No.	Stroke L_s		Thread length			
	Nominal	Maximum	L_t	L_1	L_a	L_o
W0802KA-1PY-C3Z1	150	155	190	194	202	248

- Notes:
- 1. Only rust preventive agent is applied at time of delivery. Please apply lubricant (oil or grease) before use.**
See page D13 for details.
Use of NSK Clean Grease LG2 is recommended.
 - Ball nut does not have seal.
 - Contact NSK if the permissible rotational speed is to be exceeded.

Lead accuracy			Shaft run-out **	Mass (kg)	Permissible rotational speed N (min ⁻¹)
T	e_p	v_u			Supporting condition
0	0.010	0.008	0.035	0.12	Fixed - Simple support 3 000

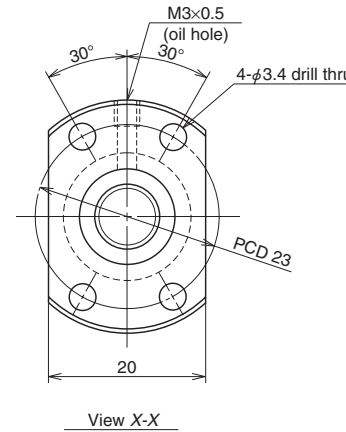
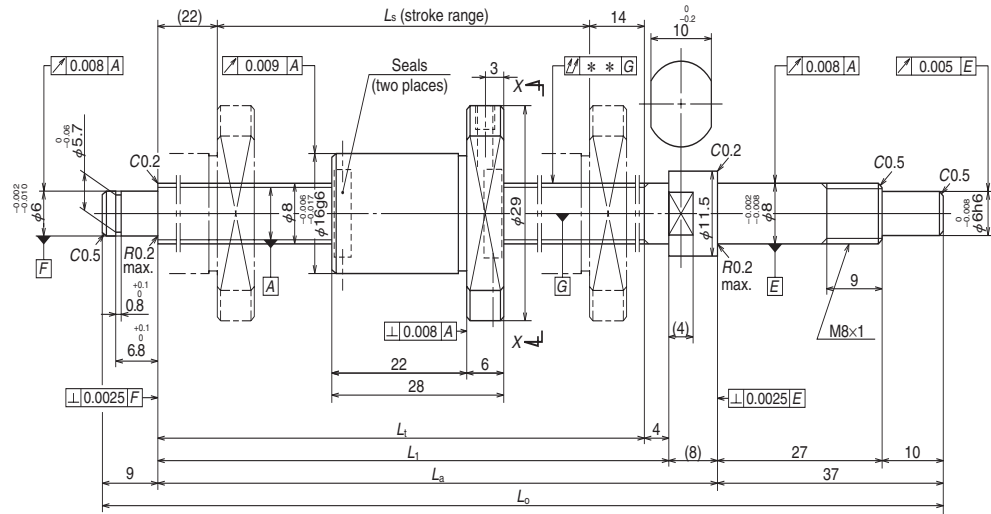

Ball screw specifications		
Shaft dia. x Lead / Direction of turn	8 × 2 / Right	
Preload / Ball recirculation	P-preload / Deflector (bridge)	
Ball dia. / Ball circle dia.	1.200 / 8.3	
Screw shaft root diameter	6.9	
Effective turns of balls	1 × 3	
Accuracy grade / Preload	C3 / Z	
Basic load rating (N)	Dynamic C_a	1 080
	Static C_{0a}	1 630
Axial play	0	
Preload (N)	49.0	
Dynamic friction torque, (N·cm)	2.0 or less	
Spacer ball	None	
Factory-packed grease	Refer to Notes 1.	
Internal spatial volume of nut (cm ³)	0.34	
Standard volume of grease replenishing (cm ³)	0.17	

Recommended support unit

For drive side (Fixed)	For opposite to drive side (Free)
WBK08-01C (square, clean)	WBK08S-01C (square, clean)
WBK08-11C (round, clean)	

Unit: mm

Ball screw No.	Stroke L_s		Thread length			
	Nominal	Maximum	L_1	L_1	L_a	L_o
W0802KA-5PY-C3Z2	150	154	190	194	202	248

Lead accuracy			Shaft run-out **	Mass (kg)	Permissible rotational speed N (min ⁻¹)
T	e_p	v_u			Supporting condition
0	0.010	0.008	0.035	0.13	Fixed - Simple support 3 000

- Notes:
1. Only rust preventive agent is applied at time of delivery. Please apply lubricant (oil or grease) before use. See page D13 for details. Use of NSK Clean Grease LG2 is recommended.
 2. Contact NSK if the permissible rotational speed is to be exceeded.

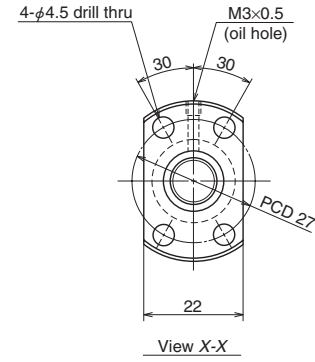
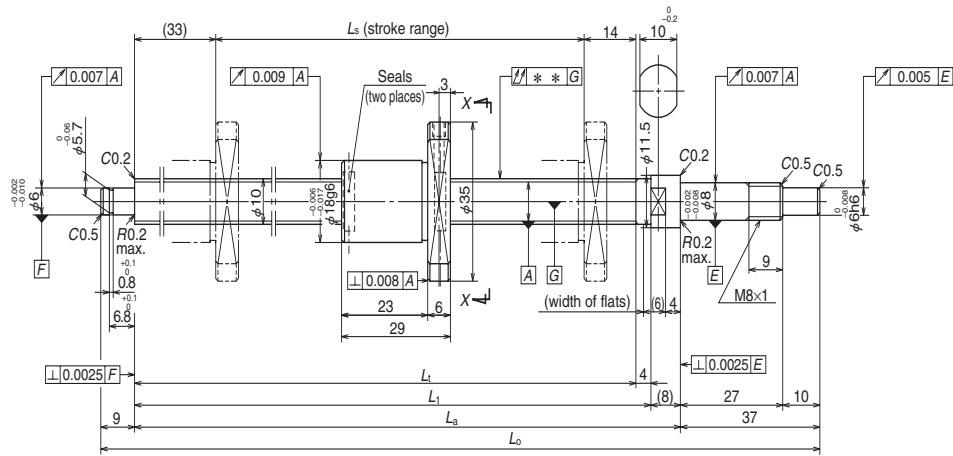

Ball screw specifications

Shaft dia. x Lead / Direction of turn	10 x 2 / Right	
Preload / Ball recirculation	P-preload / Deflector (bridge)	
Ball dia. / Ball circle dia.	1.200 / 10.3	
Screw shaft root diameter	8.9	
Effective turns of balls	1 x 3	
Accuracy grade / Preload	C3 / Z	
Basic load rating (N)	Dynamic C_a	1 210
	Static C_{0a}	2 110
Axial play	0	
Preload (N)	58.8	
Dynamic friction torque, (N-cm)	0.10 - 2.5	
Spacer ball	None	
Factory-packed grease	Refer to Notes 1.	
Internal spatial volume of nut (cm ³)	0.44	
Standard volume of grease replenishing (cm ³)	0.22	

Recommended support unit

For drive side (Fixed)	For opposite to drive side (Free)
WBK08-01C (square, clean)	WBK08S-01C (square, clean)
WBK08-11C (round, clean)	

Ball screw No.	Stroke L_s		Thread length			
	Nominal	Maximum	L_1	L_1	L_a	L_b
W1002KA-3PY-C3Z2	200	203	250	254	262	308

Lead accuracy			Shaft run-out **	Mass (kg)	Permissible rotational speed N (min ⁻¹)
T	e_p	v_u			Supporting condition
0	0.012	0.008	0.030	0.22	Fixed - Simple support 3 000

- Notes: **1. Only rust preventive agent is applied at time of delivery. Please apply lubricant (oil or grease) before use.**
 See page D13 for details.
 Use of NSK Clean Grease LG2 is recommended.
2. Contact NSK if the permissible rotational speed is to be exceeded.

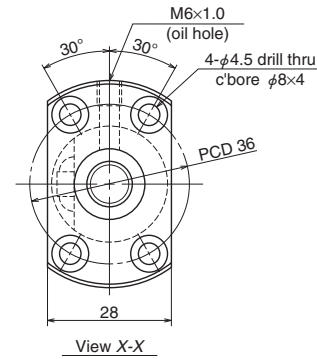
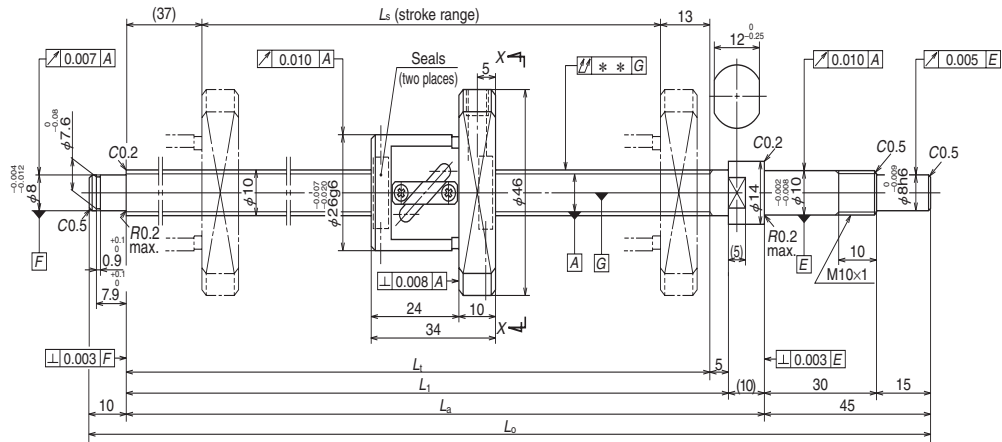

Ball screw specifications

Shaft dia. x Lead / Direction of turn	10 x 4 / Right	
Preload / Ball recirculation	P-preload / Return tube	
Ball dia. / Ball circle dia.	2.000 / 10.3	
Screw shaft root diameter	8.2	
Effective turns of balls	2.5 x 1	
Accuracy grade / Preload	C3 / Z	
Basic load rating (N)	Dynamic C_a	2 250
	Static C_{0a}	3 290
Axial play	0	
Preload (N)	98.1	
Dynamic friction torque, (N-cm)	0.5 - 3.9	
Spacer ball	None	
Factory-packed grease	Refer to NOTES 1.	
Internal spatial volume of nut (cm ³)	0.8	
Standard volume of grease replenishing (cm ³)	0.4	

Recommended support unit

For drive side (Fixed)	For opposite to drive side (Free)
WBK10-01C (square, clean)	WBK10S-01C (square, clean)
WBK10-11C (round, clean)	

Ball screw No.	Stroke L_s		Thread length			
	Nominal	Maximum	L_1	L_1	L_a	L_o
W1001KA-3P-C3Z4	100	110	160	165	175	230
W1003KA-3P-C3Z4	300	310	360	365	375	430

Lead accuracy			Shaft run-out **	Mass (kg)	Permissible rotational speed N (min ⁻¹)
T	e_p	v_u			Supporting condition
0	0.010	0.008	0.030	0.29	3 000
0	0.013	0.008	0.050	0.39	3 000

Notes: 1. Only rust preventive agent is applied at time of delivery. Please apply lubricant (oil or grease) before use.

See page D13 for details.

Use of NSK Clean Grease LG2 is recommended.

2. Contact NSK if the permissible rotational speed is to be exceeded.

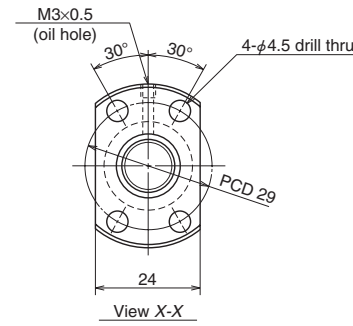
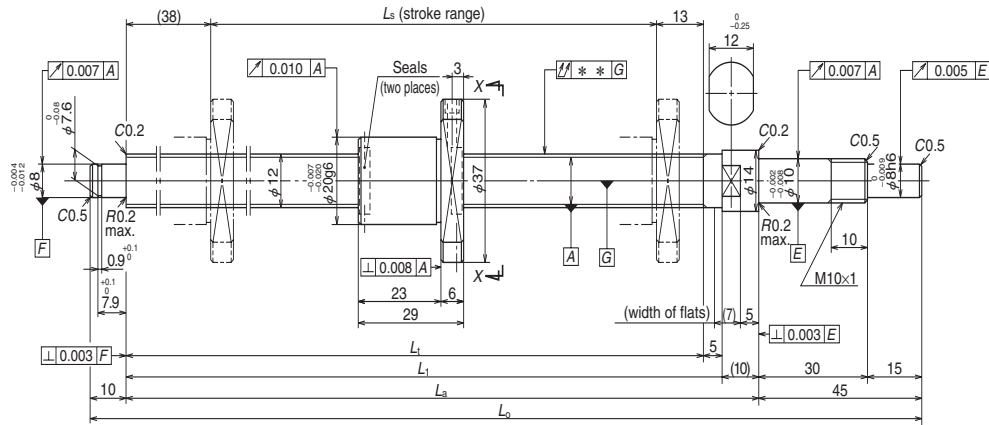

Ball screw specifications		
Shaft dia. x Lead / Direction of turn	12 x 2 / Right	
Preload / Ball recirculation	P-preload / Deflector (bridge)	
Ball dia. / Ball circle dia.	1.200 / 12.3	
Screw shaft root diameter	10.9	
Effective turns of balls	1 x 3	
Accuracy grade / Preload	C3 / Z	
Basic load rating (N)	Dynamic C_a	1 360
	Static C_{0a}	2 680
Axial play	0	
Preload (N)	98.1	
Dynamic friction torque, (N-cm)	0.4 – 3.4	
Spacer ball	None	
Factory-packed grease	Refer to NOTES 1.	
Internal spatial volume of nut (cm ³)	0.53	
Standard volume of grease replenishing (cm ³)	0.27	

Recommended support unit

For drive side (Fixed)	For opposite to drive side (Free)
WBK10-01C (square, clean)	WBK10S-01C (square, clean)
WBK10-11C (round, clean)	

Unit: mm

Ball screw No.	Stroke L_s		Thread length			
	Nominal	Maximum	L_1	L_2	L_3	L_4
W1201KA-3PY-C3Z2	100	109	160	165	175	230
W1203KA-1PY-C3Z2	250	259	310	315	325	380

Lead accuracy			Shaft run-out **	Mass (kg)	Permissible rotational speed N (min ⁻¹)
T	e_p	v_u			Supporting condition
					Fixed - Simple support
0	0.010	0.008	0.030	0.24	3 000
0	0.012	0.008	0.040	0.36	3 000

- Notes:
1. Only rust preventive agent is applied at time of delivery. Please apply lubricant (oil or grease) before use. See page D13 for details. Use of NSK Clean Grease LG2 is recommended.
 2. Contact NSK if the permissible rotational speed is to be exceeded.

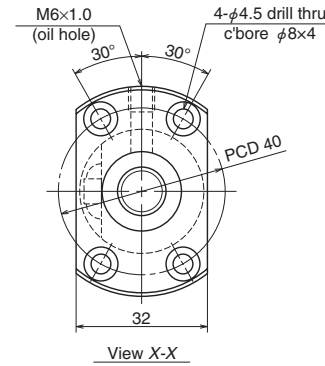
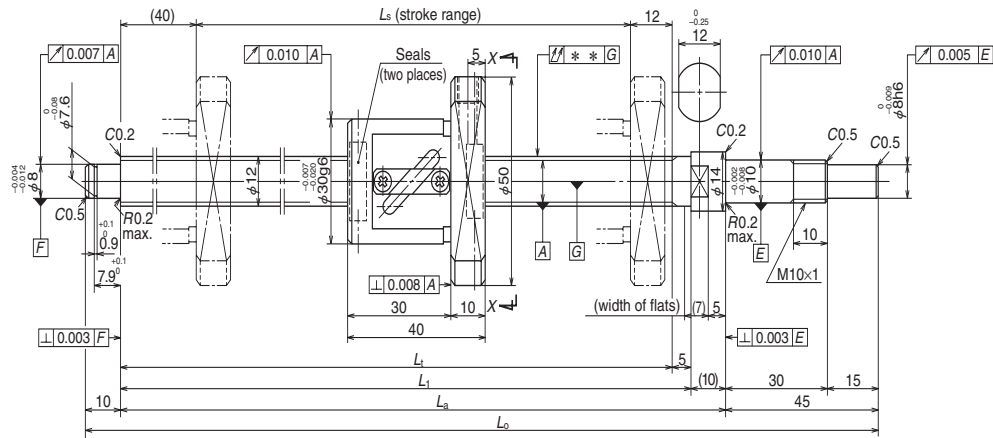

Ball screw specifications		
Shaft dia. x Lead / Direction of turn	12 x 5 / Right	
Preload / Ball recirculation	P-preload / Return tube	
Ball dia. / Ball circle dia.	2.381 / 12.3	
Screw shaft root diameter	9.8	
Effective turns of balls	2.5 x 1	
Accuracy grade / Preload	C3 / Z	
Basic load rating (N)	Dynamic C_a	3 070
	Static C_{0a}	4 670
Axial play	0	
Preload (N)	98.1	
Dynamic friction torque, (N-cm)	1.0 - 4.4	
Spacer ball	None	
Factory-packed grease	Refer to Notes 1.	
Internal spatial volume of nut (cm ³)	1.2	
Standard volume of grease replenishing (cm ³)	0.6	

Recommended support unit

For drive side (Fixed)	For opposite to drive side (Free)
WBK10-01C (square, clean)	WBK10S-01C (square, clean)
WBK10-11C (round, clean)	

Unit: mm

Ball screw No.	Stroke L_s		Thread length			
	Nominal	Maximum	L_1	L_i	L_a	L_o
W1202KA-3P-C3Z5	200	208	260	265	275	330
W1205KA-1P-C3Z5	450	458	510	515	525	580

Lead accuracy			Shaft run-out **	Mass (kg)	Permissible rotational speed N (min ⁻¹)
T	e_p	v_u			Supporting condition
					Fixed - Simple support
0	0.012	0.008	0.040	0.47	3 000
0	0.016	0.012	0.065	0.66	3 000

- Notes:
1. Only rust preventive agent is applied at time of delivery. Please apply lubricant (oil or grease) before use. See page D13 for details. Use of NSK Clean Grease LG2 is recommended.
 2. Contact NSK if the permissible rotational speed is to be exceeded.

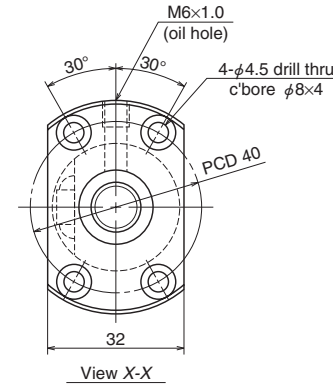
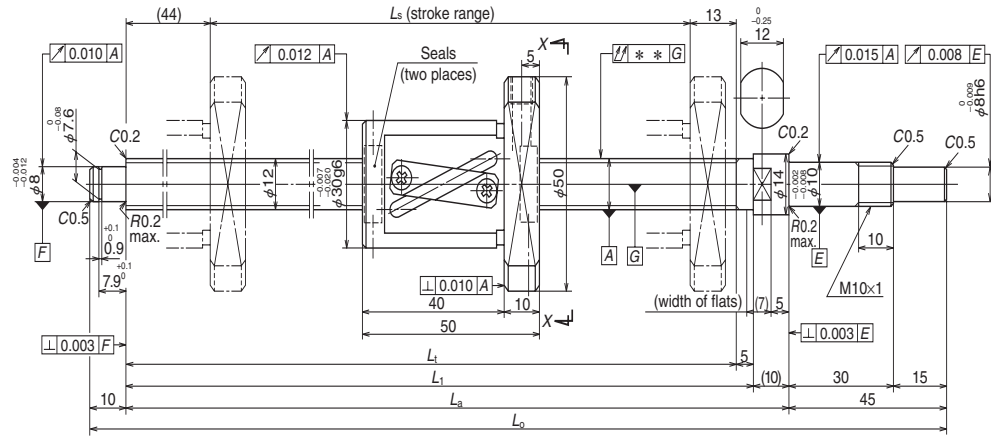

Ball screw specifications

Shaft dia. x Lead / Direction of turn	12 x 10 / Right	
Preload / Ball recirculation	P-preload / Return tube	
Ball dia. / Ball circle dia.	2.381 / 12.5	
Screw shaft root diameter	10.0	
Effective turns of balls	2.5 x 1	
Accuracy grade / Preload	C5 / Z	
Basic load rating (N)	Dynamic C_a	3 070
	Static C_{0a}	4 790
Axial play	0	
Preload (N)	98.1	
Dynamic friction torque, (N-cm)	1.0 - 4.9	
Spacer ball	None	
Factory-packed grease	Refer to NOTES 1.	
Internal spatial volume of nut (cm ³)	1.4	
Standard volume of grease replenishing (cm ³)	0.7	

Recommended support unit

For drive side (Fixed)	For opposite to drive side (Free)
WBK10-01C (square, clean)	WBK10S-01C (square, clean)
WBK10-11C (round, clean)	

Unit: mm

Ball screw No.	Stroke L_s		Thread length			
	Nominal	Maximum	L_t	L_1	L_a	L_o
W1203KA-3P-C5Z10	250	253	310	315	325	380
W1205KA-3P-C5Z10	450	453	510	515	525	580

Lead accuracy			Shaft run-out **	Mass (kg)	Permissible rotational speed N (min ⁻¹)
T	e_p	v_u			Supporting condition
0	0.023	0.018	0.050	0.56	3 000
0	0.030	0.023	0.075	0.72	3 000

- Notes:
1. Only rust preventive agent is applied at time of delivery. Please apply lubricant (oil or grease) before use. See page D13 for details. Use of NSK Clean Grease LG2 is recommended.
 2. Contact NSK if the permissible rotational speed is to be exceeded.

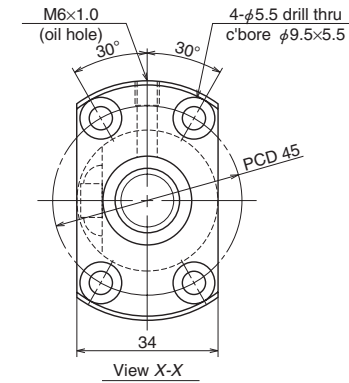
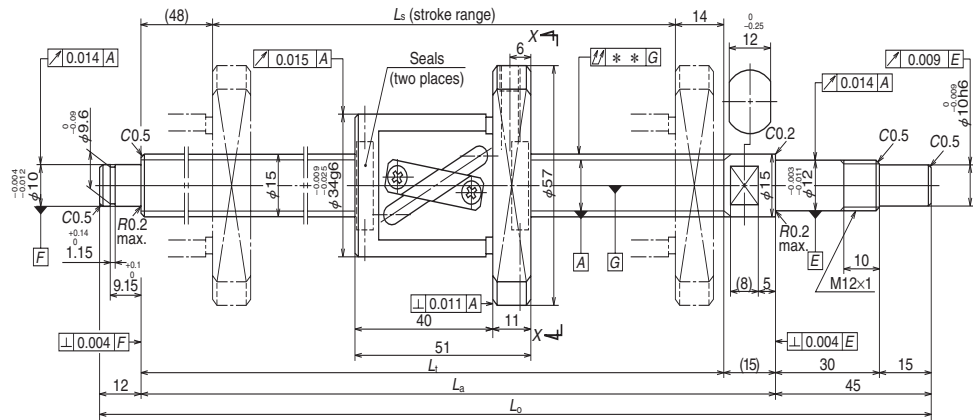

Ball screw specifications

Shaft dia. x Lead / Direction of turn	15 × 10 / Right	
Preload / Ball recirculation	P-preload / Return tube	
Ball dia. / Ball circle dia.	3.175 / 15.5	
Screw shaft root diameter	12.2	
Effective turns of balls	2.5 × 1	
Accuracy grade / Preload	C5 / Z	
Basic load rating (N)	Dynamic C_a	5 780
	Static C_{0a}	9 430
Axial play	0	
Preload (N)	147	
Dynamic friction torque, (N-cm)	1.5 – 7.9	
Spacer ball	None	
Factory-packed grease	Refer to Notes 1.	
Internal spatial volume of nut (cm ³)	2.3	
Standard volume of grease replenishing (cm ³)	1.4	

Recommended support unit

For drive side (Fixed)	For opposite to drive side (Free)
WBK12-01C (square, clean)	WBK12S-01C (square, clean)
WBK12-11C (round, clean)	

Ball screw No.	Stroke L_s		Thread length		
	Nominal	Maximum	L_t	L_a	L_o
			W1504KA-3P-C5Z10	400	427
W1506KA-3P-C5Z10	600	627	689	704	761
W1510KA-1P-C5Z10	1 000	1 027	1 089	1 104	1 161

Lead accuracy			Shaft run-out **	Mass (kg)	Permissible rotational speed N (min ⁻¹)
T	e_p	v_u			Supporting condition
0	0.027	0.020	0.050	0.99	3 000
0	0.035	0.025	0.065	1.2	3 000
0	0.046	0.030	0.110	1.7	1 610

- Notes:
1. Only rust preventive agent is applied at time of delivery. Please apply lubricant (oil or grease) before use. See page D13 for details. Use of NSK Clean Grease LG2 is recommended.
 2. Contact NSK if the permissible rotational speed is to be exceeded.

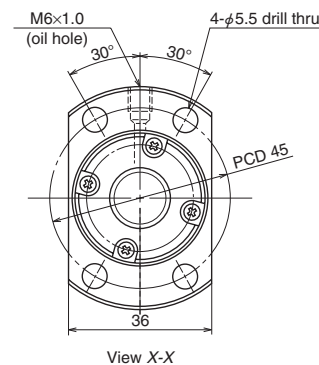
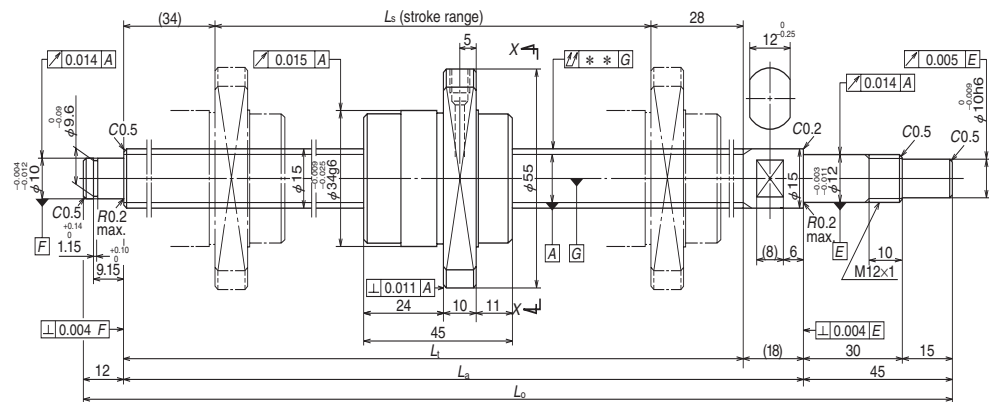

Ball screw specifications		
Shaft dia. x Lead / Direction of turn	15 × 20 / Right	
Preload / Ball recirculation	P-preload / End cap	
Ball dia. / Ball circle dia.	3.175 / 15.5	
Screw shaft root diameter	12.2	
Effective turns of balls	1.7 × 1	
Accuracy grade / Preload	C5 / Z	
Basic load rating (N)	Dynamic C_a	4 150
	Static C_{0a}	6 450
Axial play	0	
Preload (N)	147	
Dynamic friction torque, (N-cm)	1.5 – 7.9	
Spacer ball	None	
Factory-packed grease	Refer to Notes 1.	
Internal spatial volume of nut (cm ³)	1.9	
Standard volume of grease replenishing (cm ³)	1.0	

Recommended support unit

For drive side (Fixed)	For opposite to drive side (Free)
WBK12-01C (square, clean)	WBK12S-01C (square, clean)
WBK12-11C (round, clean)	

Unit: mm

Ball screw No.	Stroke L_s		Thread length		
	Nominal	Maximum	L_1	L_2	L_3
W1504KA-7PG-C5Z20	400	424	486	504	561
W1506KA-7PG-C5Z20	600	624	686	704	761
W1510KA-3PG-C5Z20	1 000	1 024	1 086	1 104	1 161

Lead accuracy			Shaft run-out **	Mass (kg)	Permissible rotational speed N (min ⁻¹)
T	e_p	v_u			Supporting condition
					Fixed - Simple support
0	0.027	0.020	0.050	1.0	3 000
0	0.035	0.025	0.065	1.3	3 000
0	0.046	0.030	0.110	1.8	1 610

- Notes:
1. Only rust preventive agent is applied at time of delivery. Please apply lubricant (oil or grease) before use. See page D13 for details. Use of NSK Clean Grease LG2 is recommended.
 2. Contact NSK if the permissible rotational speed is to be exceeded.

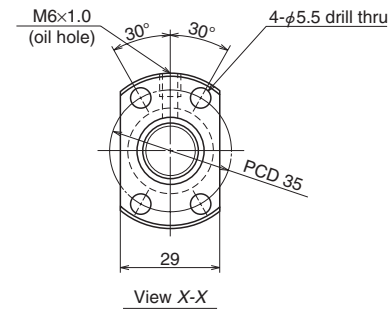
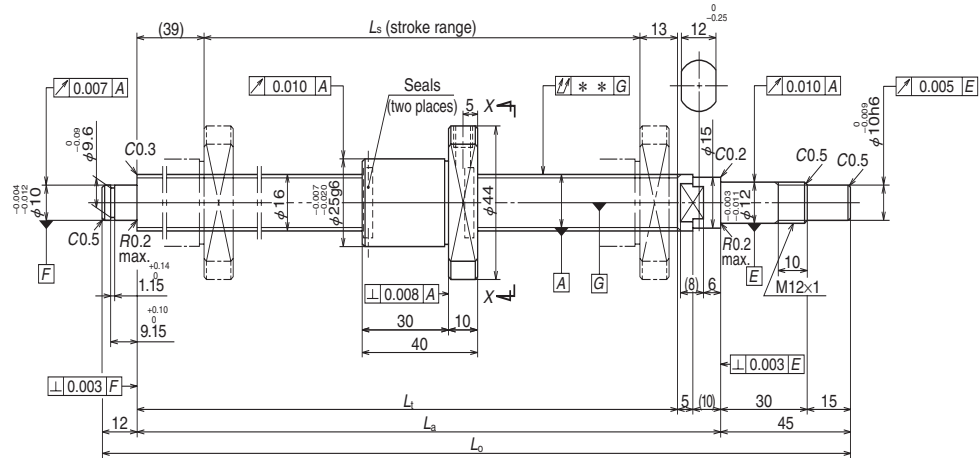

Ball screw specifications		
Shaft dia. x Lead / Direction of turn	16 x 2 / Right	
Preload / Ball recirculation	P-preload / Deflector (bridge)	
Ball dia. / Ball circle dia.	1.588 / 16.4	
Screw shaft root diameter	14.6	
Effective turns of balls	1 x 4	
Accuracy grade / Preload	C3 / Z	
Basic load rating (N)	Dynamic C_a	2 870
	Static C_{0a}	6 250
Axial play	0	
Preload (N)	147	
Dynamic friction torque, (N-cm)	0.5 – 4.9	
Spacer ball	None	
Factory-packed grease	Refer to NOTES 1.	
Internal spatial volume of nut (cm ³)	1.6	
Standard volume of grease replenishing (cm ³)	0.8	

Recommended support unit

For drive side (Fixed)	For opposite to drive side (Free)
WBK12-01C (square, clean)	WBK12S-01C (square, clean)
WBK12-11C (round, clean)	

Unit: mm

Ball screw No.	Stroke L_s		Thread length		
	Nominal	Maximum	L_1	L_a	L_o
W1601KA-3PY-C3Z2	100	137	189	204	261
W1603KA-1PY-C3Z2	300	337	389	404	461

Lead accuracy			Shaft run-out **	Mass (kg)	Permissible rotational speed N (min ⁻¹)
T	e_p	v_u			Supporting condition
0	0.010	0.008	0.020	0.46	3 000
0	0.013	0.010	0.035	0.75	3 000

- Notes:
1. Only rust preventive agent is applied at time of delivery. Please apply lubricant (oil or grease) before use. See page D13 for details. Use of NSK Clean Grease LG2 is recommended.
 2. Contact NSK if the permissible rotational speed is to be exceeded.

Finished shaft end stainless steel product KA Type

(High helix lead)

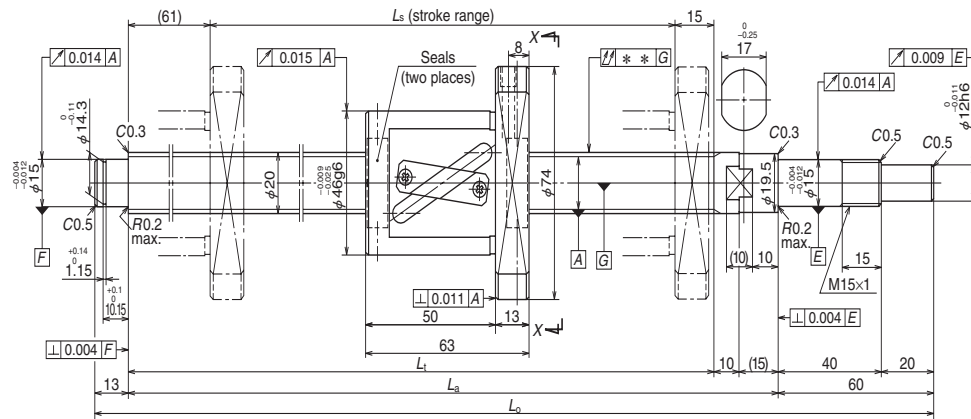

Nut model: LPFT

NSK

Screw shaft ø20

Lead 20

Unit: mm

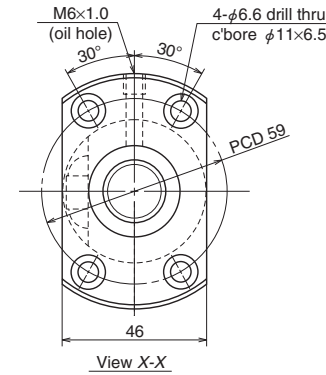

Ball screw specifications

Shaft dia. x Lead / Direction of turn	20 × 20 / Right	
Preload / Ball recirculation	P-preload / Return tube	
Ball dia. / Ball circle dia.	3.969 / 21	
Screw shaft root diameter	16.9	
Effective turns of balls	1.5 × 1	
Accuracy grade / Preload	C5 / Z	
Basic load rating (N)	Dynamic C_a	5 760
	Static C_{0a}	9 370
Axial play	0	
Preload (N)	196	
Dynamic friction torque, (N-cm)	2.0 – 11.8	
Spacer ball	None	
Factory-packed grease	Refer to NOTES 1.	
Internal spatial volume of nut (cm ³)	4.2	
Standard volume of grease replenishing (cm ³)	2.1	

Recommended support unit

For drive side (Fixed)	For opposite to drive side (Free)
WBK15-01C (square, clean)	WBK15S-01C (square, clean)
WBK15-11C (round, clean)	

Unit: mm

Ball screw No.	Stroke L_s		Thread length		
	Nominal	Maximum	L_t	L_a	L_o
W2005KA-3P-C5Z20	400	434	510	535	608
W2007KA-3P-C5Z20	600	634	710	735	808
W2011KA-3P-C5Z20	1 000	1 034	1 110	1 135	1 208

Lead accuracy			Shaft run-out **	Mass (kg)	Permissible rotational speed N (min ⁻¹)
T	e_p	v_u			Supporting condition
0	0.030	0.023	0.050	2.0	3 000
0	0.035	0.025	0.085	2.5	3 000
0	0.046	0.030	0.110	3.4	2 160

- Notes:
1. Only rust preventive agent is applied at time of delivery. Please apply lubricant (oil or grease) before use. See page D13 for details. Use of NSK Clean Grease LG2 is recommended.
 2. Contact NSK if the permissible rotational speed is to be exceeded.

B-3-1.5 Blank Shaft End MS Type, FS Type, SS Type

1. Order of the dimension tables

The dimension table begins with the smallest shaft diameter of each MS, FS and SS type ball screws, and proceed to larger sizes. If ball screws have the same shaft diameter, those with smaller leads appear first. Page numbers of shaft diameter and lead combinations are shown in the **Table 1**.

2. Dimension tables

The dimension tables show shapes/sizes as well as specification factors of each shaft diameter/lead combination. Tables also contain data as follows:

● **Lead accuracy**

Lead accuracy is either C3 or C5 grades.

T : Travel compensation

e_p : Tolerance of specified travel

v₀ : Travel variation

See "Technical Description: Lead Accuracy" (page B37) for details of the codes.

● **Permissible rotational speed**

d • *n*: Limited by the relative peripheral speed between the screw shaft and the nut.

Critical speed : Limited by the natural frequency of a ball screw shaft. Critical speed depends on the supporting condition of screw shaft.

Criterion of maximum rotational speed

: 3 000 min⁻¹

The lower of the two criteria, *d*•*n* and critical speed, will determine the overall permissible rotational speed of the ball screw. For details, see "Technical Description: Permissible Rotational Speed" (page B47).

3. Shaft end processing

MS, FS, and SS types require shaft end processing to your specification. The exclusive support units (page B389) are available to design the bearing seats. See "Configuration of shaft end" (page B27 and following pages) when

using a support unit. See "Technical Description: Shaft End Processing" (page B86) for procedures of shaft end processing and precautions.

4. Other

The seals of the ball screw, ball recirculating deflectors and end caps are made of synthetic resin. Consult NSK when using the ball screws under extreme environments or special environments, or using special lubricant or oil. For special environments, see pages B70 and D2. See pages B67 and D13 for lubricants. Note: For details of standard stock products, contact NSK.

Table 1 Combinations of screw shaft diameter and lead

Screw shaft diameter(mm) \ Lead(mm)	1	1.5	2	2.5	4	5	6
4	B301						
6	B301						
8	B301	B303	B303				
10			B303	B305	B309		
12			B305	B305		B309	
14						B311	
15							
16			B307	B307		B315	
20					B321	B321	
25					B323	B323 B325	B323
28						B327 B329	B327 B329
32						B331 B333 B335	B331 B333
36							
40						B337	
45							
50							

	8	10	12	16	20	25	32	40	50
		B309							
B311		B311			B313				
				B315			B313		
		B315			B315			B313	
		B325 B327			B317	B317			B317
B333		B335 B337 B339				B319	B319		
		B337 B339							
		B341 B343 B345	B341 B343						
B341		B347							
		B345 B347							

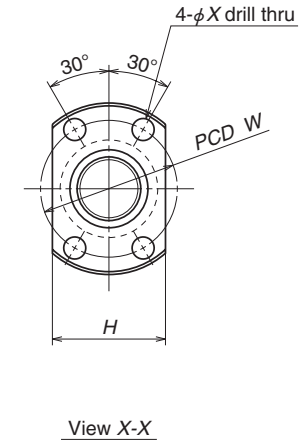
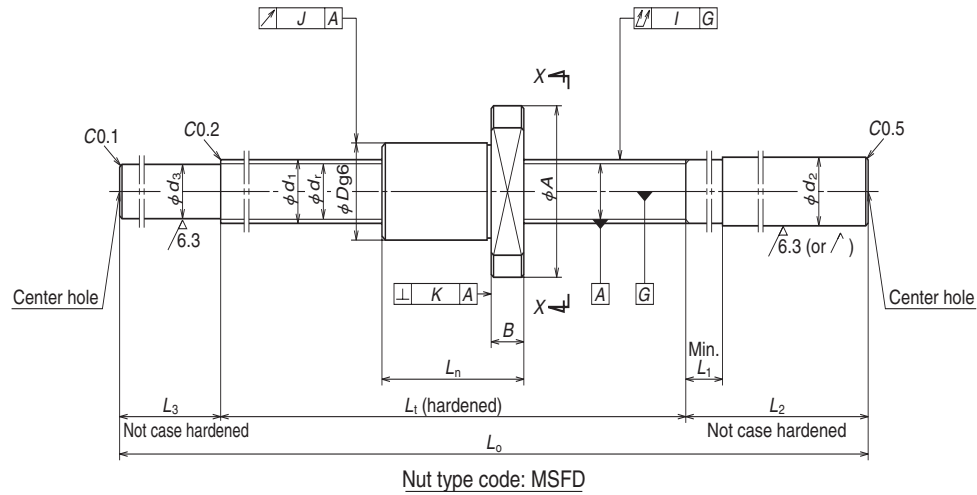

Ball screw No.	Stroke Max. L_r-L_n	Screw shaft dia. d_1	Lead l	Ball dia. D_w	Ball circle dia. d_m	Root dia. d_r	Effective ball turns	Basic load rating (N)		Axial play Max.	Nut			
								Dynamic C_a	Static C_{0a}		Flange			
											Outside dia. D	A	H	B
W0400MS-1Y-C3T1	68	4	1	0.8	4.2	3.2	2	315	370	0.005	10	20	14	3
W0601MS-1Y-C3T1	110	6	1	0.8	6.2	5.2	3	575	925	0.005	12	24	16	3.5
W0801MS-1Y-C3T1	94	8	1	0.8	8.2	7.2	3	670	1290	0.005	14	27	18	4
W0802MS-1Y-C3T1	174													

- Notes: 1. Use of NSK support unit is recommended. See page B389 for details.
 2. Only rust preventive agent is applied at time of delivery. Please apply lubricant (oil or grease) before use. See page D13 for details.
 3. Ball nut does not have seal.
 4. The permissible rotational speed is determined by d-n value, critical speed, and maximum rotational speed. See B299 and B47. The permissible rotational speed shown in the table is the value when the ball screw mounting method is Fixed-Fixed.

Unit: mm

dimensions			Screw shaft dimensions							Lead accuracy			Run-out			Mass (kg)	Permissible rotational speed N (min ⁻¹)
Overall length L_n	Bolt hole		Threaded length L_1	Shaft end, right		Shaft end, left		Overall length L_0	T	Deviation e_p	Variation v_u	Shaft straightness I	Nut O.D. eccentricity J	Flange perpendicularity K			
	W	X		d_2	L_1	L_2	d_3								L_3		
12	15	2.9	80	6.0	4	40	3.3	10	130	0	0.008	0.008	0.030	0.009	0.008	0.026	3 000
15	18	3.4	125	8.0	4	50	5.3	15	190	0	0.010	0.008	0.030	0.009	0.008	0.063	3 000
16	21	3.4	110	10.2	4	60	7.3	25	195	0	0.010	0.008	0.030	0.009	0.008	0.11	3 000
			190						0.050				0.14				

Blank shaft end MS type

(Fine lead: Deflector (bridge) type)

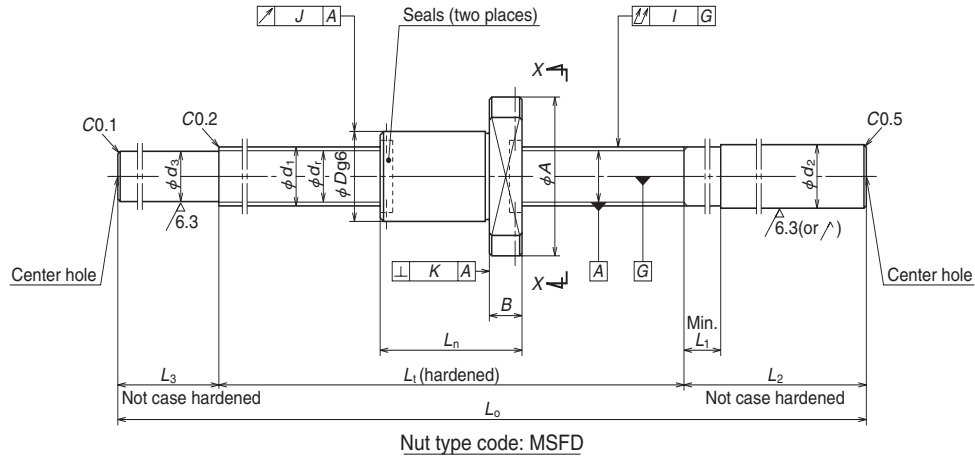

Nut model: MSFD

NSK

Screw shaft ø8

Lead 1.5, 2

Screw shaft ø10

Lead 2

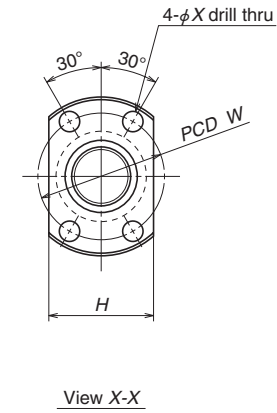

Ball screw No.	Stroke Max. L ₁ -L _n	Screw shaft dia. d ₁	Lead l	Ball dia. D _w	Ball circle dia. d _m	Root dia. d _t	Effective ball turns	Basic load rating (N)		Axial play Max.	Nut								
								Dynamic C _{0a}	Static C _{0a}		Flange								
											Outside dia. D	A	H	B					
W0801MS-2Y-C3T1.5	88	8	1.5	1.0	8.3	7.0	3	1 080	1 980	0.005	15	28	19	4					
W0802MS-2Y-C3T1.5	168										110	190	10.2	4	60	7.2	25	195	275
W0801MS-3Y-C3T2	84	8	2	1.2	8.3	6.9	3	1 320	2 210	0.005	16	29	20	4					
W0802MS-3Y-C3T2	164										110	190	10.2	4	60	7.0	25	195	275
W1001MS-1Y-C3T2	122	10	2	1.2	10.3	8.9	3	1 490	2 850	0.005	18	35	22	5					
W1002MS-1Y-C3T2	222										150	250	12.2	4	70	9.0	30	250	350

Unit: mm

dimensions			Screw shaft dimensions						Lead accuracy			Run-out			Mass (kg)	Permissible rotational speed N (min ⁻¹)	
Overall length L _n	Bolt hole W X		Threaded length L ₁	Shaft end, right d ₂ L ₁ L ₂		Shaft end, left d ₃ L ₃		Overall length L ₀	T	Deviation e _p	Variation v _u	Shaft straightness I	Nut O.D. eccentricity J	Flange perpendicularity K			
22	22	3.4	110	10.2	4	60	7.2	25	195	0	0.010	0.008	0.030	0.009	0.008	0.12	3 000
			190						275				0.050			0.15	
26	23	3.4	110	10.2	4	60	7.0	25	195	0	0.010	0.008	0.030	0.009	0.008	0.12	3 000
			190						275				0.050			0.15	
28	27	4.5	150	12.2	4	70	9.0	30	250	0	0.010	0.008	0.035	0.009	0.008	0.22	3 000
			250						350		0.012		0.050			0.17	

- Notes: 1. Use of NSK support unit is recommended. See page B389 for details.
 2. Only rust preventive agent is applied at time of delivery. Please apply lubricant (oil or grease) before use. See page D13 for details.
 3. The permissible rotational speed is determined by d-n value, critical speed, and maximum rotational speed. See B299 and B47. The permissible rotational speed shown in the table is the value when the ball screw mounting method is Fixed-Fixed.

Blank shaft end MS type

(Fine lead: Deflector (bridge) type)

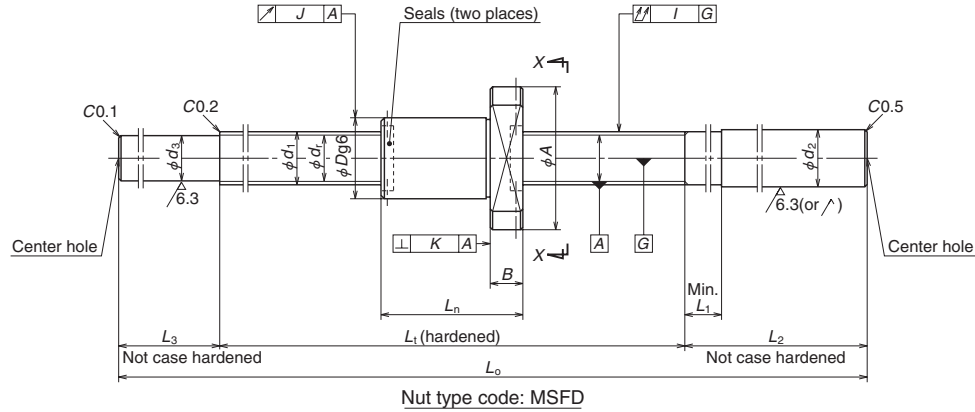

Nut model: MSFD

NSK

Screw shaft ø10

Lead 2.5

Screw shaft ø12

Lead 2, 2.5

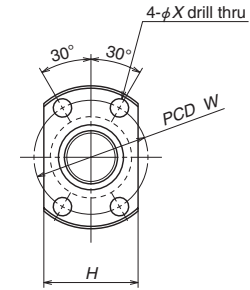

View X-X

Ball screw No.	Stroke Max. L_1-L_n	Screw shaft dia. d_1	Lead l	Ball dia. D_w	Ball circle dia. d_m	Root dia. d_r	Effective ball turns	Basic load rating (N)		Axial play Max.	Nut			
								Dynamic C_a	Static C_{0a}		Flange			
											Outside dia. D	A	H	B
W1001MS-2Y-C3T2.5	118	10	2.5	1.588	10.4	8.6	3	2 130	3 640	0.005	19	36	23	5
W1002MS-2Y-C3T2.5	218													
W1202MS-1Y-C3T2	182	12	2	1.200	12.3	10.9	3	1 660	3 620	0.005	20	37	24	5
W1203MS-1Y-C3T2	282													
W1202MS-2Y-C3T2.5	178	12	2.5	1.588	12.4	10.6	3	2 360	4 540	0.005	21	38	25	5
W1203MS-2Y-C3T2.5	278													

- Notes: 1. Use of NSK support unit is recommended. See page B389 for details.
 2. Only rust preventive agent is applied at time of delivery. Please apply lubricant (oil or grease) before use. See page D13 for details.
 3. The permissible rotational speed is determined by d-n value, critical speed, and maximum rotational speed. See B299 and B47. The permissible rotational speed shown in the table is the value when the ball screw mounting method is Fixed-Fixed.

Unit: mm

dimensions			Screw shaft dimensions						Lead accuracy			Run-out			Mass (kg)	Permissible rotational speed N (min ⁻¹)	
Overall length L_n	Bolt hole W, X		Threaded length L_1	Shaft end, right d_2, L_1, L_2		Shaft end, left d_3, L_3		Overall length L_o	T	Deviation e_p	Variation v_u	Shaft straightness I	Nut O.D. eccentricity J	Flange perpendicularity K			
32	28	4.5	150	12.2	4	70	8.7	30	250	0	0.010	0.008	0.035	0.010	0.008	0.23	3 000
			250						0.050				0.28				
28	29	4.5	210	14.2	5	80	11.0	35	325	0	0.012	0.008	0.050	0.010	0.008	0.36	3 000
			310						0.060				0.44				
32	30	4.5	210	14.2	5	80	10.7	35	325	0	0.012	0.008	0.050	0.010	0.008	0.37	3 000
			310						0.060				0.45				

Blank shaft end MS type

(Fine lead: Deflector (bridge) type)

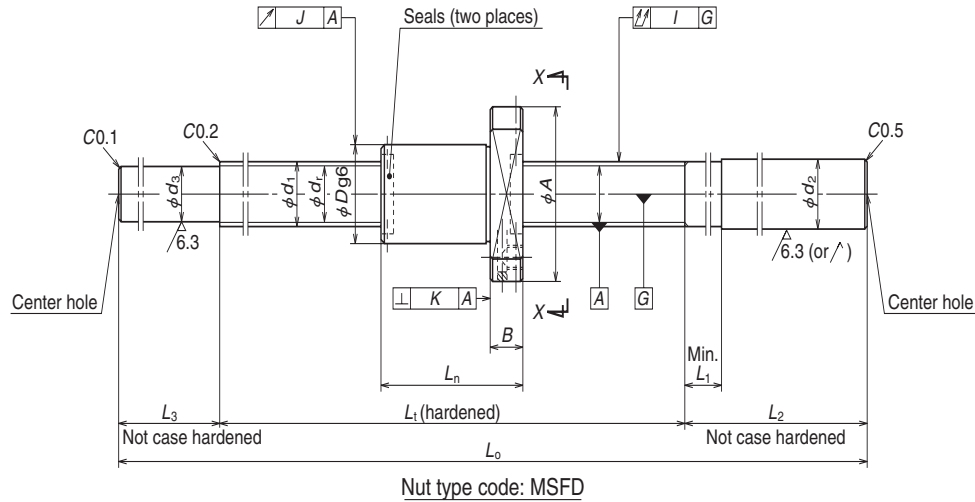

Nut type code: MSFD

Nut model: MSFD

NSK

Screw shaft ø16

Lead 2, 2.5

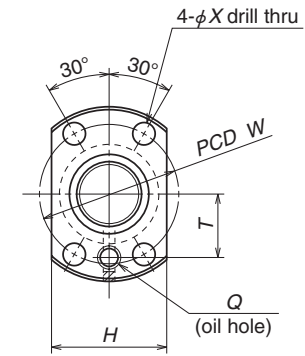

View X-X

Ball screw No.	Stroke Max. L_1-L_n	Screw shaft dia. d_1	Lead l	Ball dia. D_w	Ball circle dia. d_m	Root dia. d_r	Effective ball turns	Basic load rating (N)		Axial play Max.	Nut						
								Dynamic C_a	Static C_{0a}		Outside dia. D	Flange			Overall length L_n	Bolt hole	
												A	H	B		L_1	W
W1602MS-1Y-C3T2	210	16	2	1.588	16.4	14.6	4	3 510	8 450	0.005	25	44	29	10	40	35	5.5
W1604MS-1Y-C3T2	360										25	44	29	10	40	35	5.5
W1602MS-2Y-C3T2.5	206	16	2.5	1.588	16.4	14.6	4	3 510	8 450	0.005	25	44	29	10	44	35	5.5
W1604MS-2Y-C3T2.5	356										25	44	29	10	44	35	5.5

Notes: 1. Use of NSK support unit is recommended. See page B389 for details.

2. Only rust preventive agent is applied at time of delivery. Please apply lubricant (oil or grease) before use.

See page D13 for details.

3. The permissible rotational speed is determined by d-n value, critical speed, and maximum rotational speed. See B299 and B47. The permissible rotational speed shown in the table is the value when the ball screw mounting method is Fixed-Fixed.

Unit: mm

dimensions	Screw shaft dimensions						Lead accuracy		Run-out			Mass (kg)	Permissible rotational speed N (min ⁻¹)	Internal spatial volume of nut (cm ³)	Standard volume of grease replenishing (cm ³)			
	Oil hole		Shaft end, right		Shaft end, left		Overall length L_0	Deviation e_p	Variation v_{li}	Shaft straightness I	Nut O.D. eccentricity J					Flange perpendicularity K		
	Q	T	Threaded length L_1	d_2	L_1	L_2											d_3	L_3
M6×1	16	250	16.2	30	100	14.7	40	390	0	0.012	0.008	0.035	0.010	0.008	0.71	3 000	1.5	0.8
		400						540		0.013	0.010	0.050			0.93			
M6×1	16	250	16.2	30	100	14.7	40	390	0	0.012	0.008	0.035	0.010	0.008	0.73	3 000	1.5	0.8
		400						540		0.013	0.010	0.050			0.95			

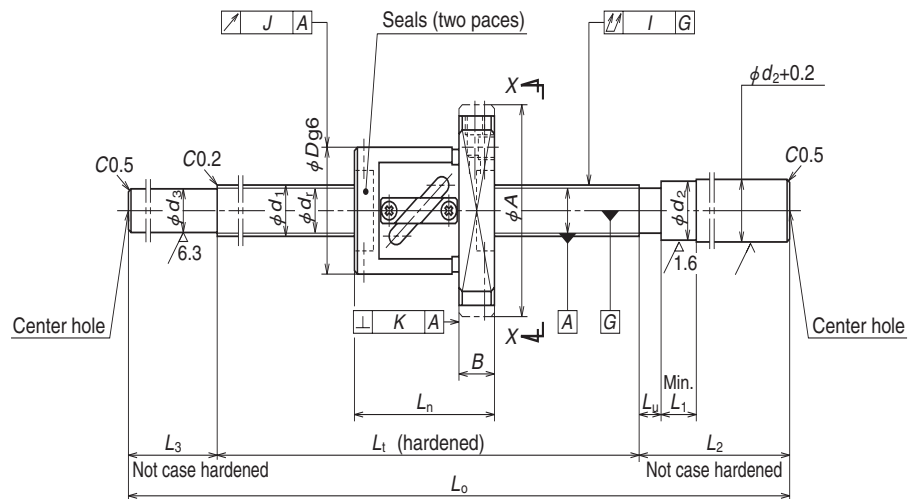

Nut type code: SFT, LSFT

Ball screw No.	Stroke Max. L_t-L_n	Screw shaft dia. d_1	Lead l	Ball dia. D_w	Ball circle dia. d_m	Root dia. d_r	Effective ball turns Turns x Circuits	Basic load rating (N)		Axial play Max.	Nut													
								Dynamic C_a	Static C_{0a}		Outside dia.		Flange		Overall length L_n	Bolt hole								
											D	A	H	K		B	W	X	Y	Z				
W1001FS-1-C3T4	126																							
W1002FS-1-C3T4	226	10	4	2.000	10.3	8.2	2.5x1	2 740	4 450	0.005	26	46	28	42	10	34	36	4.5	8	4.5				
W1003FS-1-C3T4	326																							
W1201FS-1-C3T5	110																							
W1202FS-1-C3T5	210	12	5	2.381	12.3	9.8	2.5x1	3 760	6 310	0.005	30	50	32	45	10	40	40	4.5	8	4.5				
W1204FS-1-C3T5	410																							
W1202FS-2-C5T10	200	12	10	2.381	12.5	10.0	2.5x1	3 750	6 480	0.005	30	50	32	45	10	50	40	4.5	8	4.5				
W1204FS-2-C5T10	400																							

- Notes: 1. Use of NSK support unit is recommended. See page B389 for details.
 2. Only rust preventive agent is applied at time of delivery. Please apply lubricant (oil or grease) before use. See page D13 for details.
 3. The permissible rotational speed is determined by d-n value, critical speed, and maximum rotational speed. See B299 and B47. The permissible rotational speed shown in the table is the value when the ball screw mounting method is Fixed-Fixed.

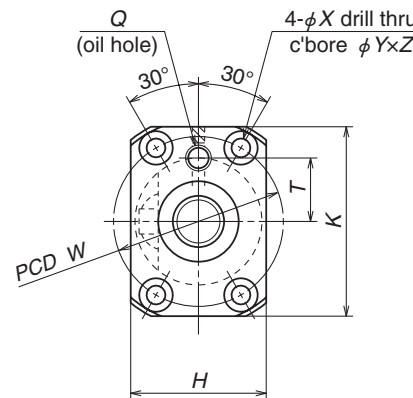

View X-X

Unit: mm

dimensions	Screw shaft dimensions							Lead accuracy			Run-out			Mass (kg)	Permissible rotational speed N (min ⁻¹)	Internal spatial volume of nut (cm ³)	Standard volume of grease replenishing (cm ³)		
	Oil hole		Threaded length	Shaft end, right		Shaft end, left		Overall length	Deviation	Variation	Shaft straightness	Nut O.D. eccentricity	Flange perpendicularity						
	Q	T		L_t	d_2	L_u	L_1											L_2	d_3
M6x1	14	160						265	0	0.010	0.008	0.030			0.34	3 000	0.86	0.43	
		260	14	5	40	70	8.2	35	365	0	0.012	0.008	0.040	0.010	0.008				0.39
		360							465		0.013	0.010	0.050						0.45
M6x1	15	150						255	0	0.010	0.008	0.030			0.44	3 000	1.2	0.6	
		250	14	5	40	70	9.8	35	355	0	0.012	0.008	0.040	0.010	0.008				0.52
		450							555		0.015	0.010	0.065						0.67
M6x1	15	250						355	0	0.023	0.018	0.050			0.57	3 000	1.4	0.7	
		450	14	8	40	70	10.0	35	555	0	0.027	0.020	0.075	0.012	0.010				0.74

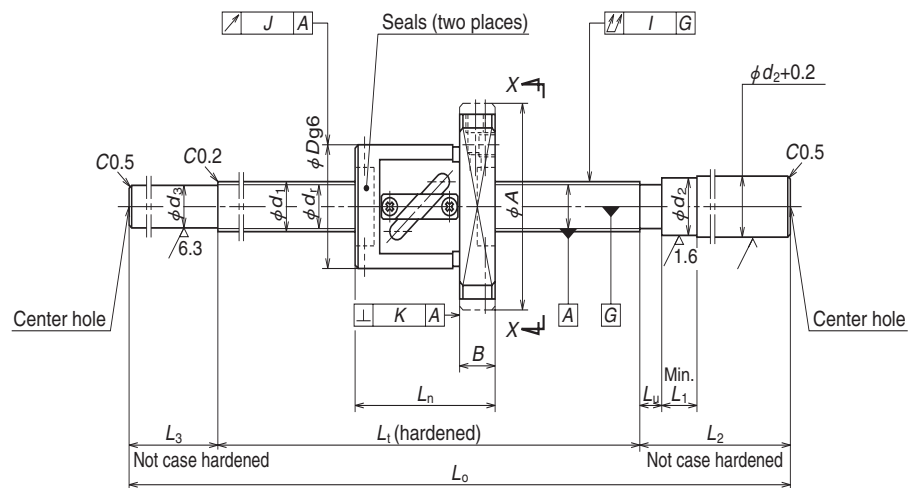

Nut type code: SFT, LSFT

Ball screw No.	Stroke Max. L_t-L_n	Screw shaft dia. d_1	Lead l	Ball dia. D_w	Ball circle dia. d_m	Root dia. d_r	Effective ball turns Turns x Circuits	Basic load rating (N)		Axial play Max.	Nut									
								Dynamic C_a	Static C_{0a}		Outside dia. D	Flange				Overall length L_n	Bolt hole			
												A	H	K	B		W	X	Y	Z
W1403FS-1-C3T5	310	14	5	3.175	14.5	11.2	2.5x1	6 790	11 700	0.005	34	57	34	50	11	40	45	5.5	9.5	5.5
W1406FS-1-C3T5	560	14	5	3.175	14.5	11.2	2.5x1	6 790	11 700	0.005	34	57	34	50	11	40	45	5.5	9.5	5.5
W1405FS-1-C5T8	454	14	8	3.175	14.5	11.2	2.5x1	6 790	11 700	0.005	34	57	34	50	11	46	45	5.5	9.5	5.5
W1408FS-1-C5T8	754	14	8	3.175	14.5	11.2	2.5x1	6 790	11 700	0.005	34	57	34	50	11	46	45	5.5	9.5	5.5
W1504FS-1-C5T10	349	15	10	3.175	15.5	12.2	2.5x1	7 070	12 800	0.005	34	57	34	50	11	51	45	5.5	9.5	5.5
W1506FS-1-C5T10	549	15	10	3.175	15.5	12.2	2.5x1	7 070	12 800	0.005	34	57	34	50	11	51	45	5.5	9.5	5.5
W1509FS-1-C5T10	849	15	10	3.175	15.5	12.2	2.5x1	7 070	12 800	0.005	34	57	34	50	11	51	45	5.5	9.5	5.5
W1511FS-1-C5T10	1 049	15	10	3.175	15.5	12.2	2.5x1	7 070	12 800	0.005	34	57	34	50	11	51	45	5.5	9.5	5.5

- Notes: 1. Use of NSK support unit is recommended. See page B389 for details.
 2. Only rust preventive agent is applied at time of delivery. Please apply lubricant (oil or grease) before use. See page D13 for details.
 3. The permissible rotational speed is determined by d-n value, critical speed, and maximum rotational speed. See B299 and B47. The permissible rotational speed shown in the table is the value when the ball screw mounting method is Fixed-Fixed.

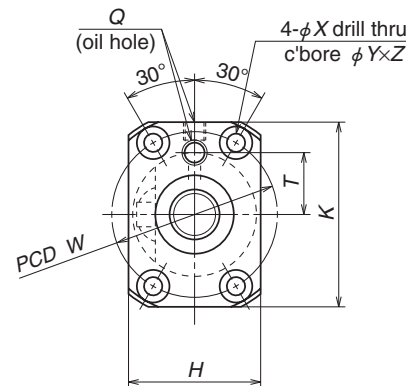

View X-X

dimensions	Screw shaft dimensions								Lead accuracy			Run-out			Mass (kg)	Permissible rotational speed N (min ⁻¹)	Internal spatial volume of nut (cm ³)	Standard volume of grease replenishing (cm ³)					
	Oil hole		Threaded length	Shaft end, right		Shaft end, left		Overall length	T	Deviation e_p	Variation v_u	Shaft straightness I	Nut O.D. eccentricity J	Flange perpendicularity K									
	Q	T		L_t	d_2	L_u	L_2												d_s	L_3	L_o		
M6x1	17	350	15	5	40	100	11.2	40	490	0	0.013	0.010	0.035	0.012	0.008	0.78	3 000	2.0	1.0				
		600																		740	0.016	0.012	0.055
M6x1	17	500	15	8	40	100	11.2	40	640	0	0.027	0.020	0.065	0.015	0.011	1.0	3 000	2.0	1.0				
		800																		940	0.035	0.025	0.085
M6x1	17	400	15	8	40	120	12.2	50	570	0	0.025	0.020	0.050	0.015	0.011	1.0	3 000	2.3	1.2				
		600																		770	0.030	0.023	0.065
		900																		1 070	0.040	0.027	0.110
		1 100																		1 270	0.046	0.030	0.150

Unit: mm

Blank shaft end FS type

(High helix, Ultra high helix: End cap type)

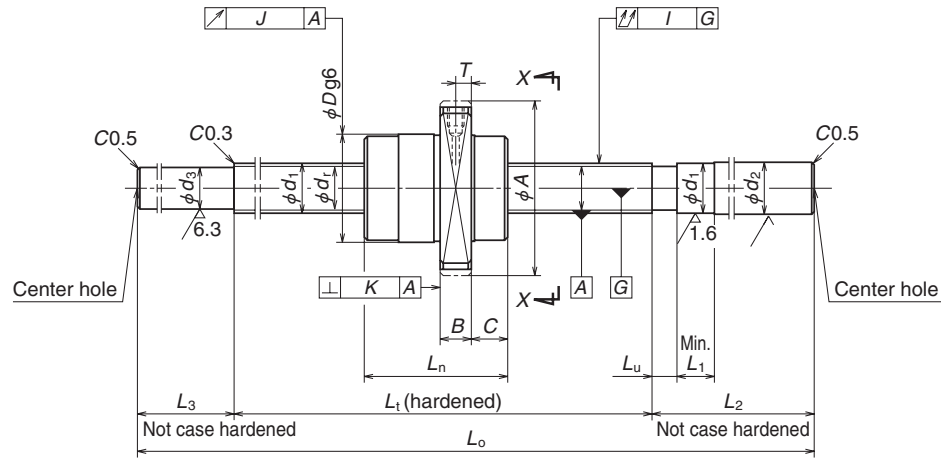

Nut type code: USFC

Nut model: USFC

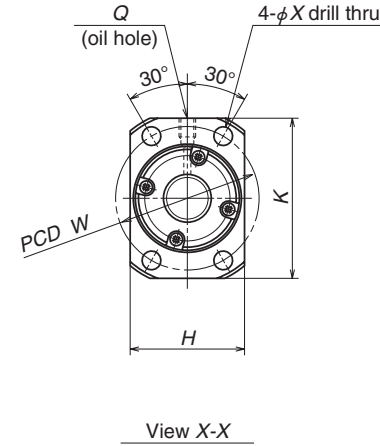

NSK

- Screw shaft ø15
- Lead 20
- Screw shaft ø16
- Lead 32
- Screw shaft ø20
- Lead 40

Ball screw No.	Stroke Max. L _r -L _n	Screw shaft dia. d ₁	Lead l	Ball dia. D _w	Ball circle dia. d _m	Root dia. d _r	Effective ball turns x Circuits	Basic load rating (N)		Axial play Max.	Nut									
								Dynamic C _a	Static C _{0a}		Flange					Overall length L _n	Bolt hole W X			
											Outside dia. D	A	H	K	B			C		
W1504FS-2G-C5T20	355	15	20	3.175	15.5	12.2	1.7x1	5 070	8 730	0.005	34	55	36	50	10	11	45	45	5.5	
W1506FS-2G-C5T20	555																			
W1509FS-2G-C5T20	855																			
W1511FS-2G-C5T20	1 055	16	32	3.175	16.75	13.4	0.7x2	4 000	6 690	0.005	34	55	36	50	10	10.5	34	45	5.5	
W1609FS-2G-C5T32	866																			
W1613FS-1GX-C5T32	1 266																			
W2011FS-1GX-C5T40	1 059	20	40	3.175	20.75	17.4	0.7x2	4 490	8 640	0.005	38	58	40	52	10	11	41	48	5.5	
W2017FS-1GX-C5T40	1 659																			

- Notes: 1. Use of NSK support unit is recommended. See page B389 for details.
 2. Only rust preventive agent is applied at time of delivery. Please apply lubricant (oil or grease) before use. See page D13 for details.
 3. The permissible rotational speed is determined by d-n value, critical speed, and maximum rotational speed. See B299 and B47. The permissible rotational speed shown in the table is the value when the ball screw mounting method is Fixed-Fixed.

dimensions	Screw shaft dimensions							Lead accuracy		Run-out			Mass (kg)	Permissible rotational speed N (min ⁻¹)	Internal spatial volume of nut (cm ³)	Standard volume of grease replenishing (cm ³)		
	Oil hole Q	Threaded length T	Shaft end, right		Shaft end, left		Overall length L _o	Lead error T	Deviation e _p	Variation v _u	Shaft straightness I	Nut O.D. eccentricity J					Flange perpendicularity K	
			L ₁	d ₂	L ₁	L ₂												d ₃
M6x1	5	400	15.2	13	40	120	12.2	50	570	0	0.025	0.020	0.050	0.015	0.011	3 000	1.9	1.0
		600							770	0.030	0.023	0.065	1.0					
		900							1 070	0.040	0.027	0.110	1.3					
		1 100							1 270	0.046	0.030	0.150	1.7					
M6x1	5	900	16.2	19	40	150	13.4	60	1 110	0	0.040	0.027	0.110	0.015	0.011	3 000	2.0	1.0
		1 300							1 510	0.054	0.035	0.150	2.5					
M6x1	5	1 100	20.2	22	60	150	17.4	80	1 330	0	0.046	0.030	0.150	0.015	0.011	3 000	2.7	1.4
		1 700							1 930	0.065	0.040	0.200	4.9					

Unit: mm

Blank shaft end FS type

(Fine, Medium, High helix lead: Tube type)

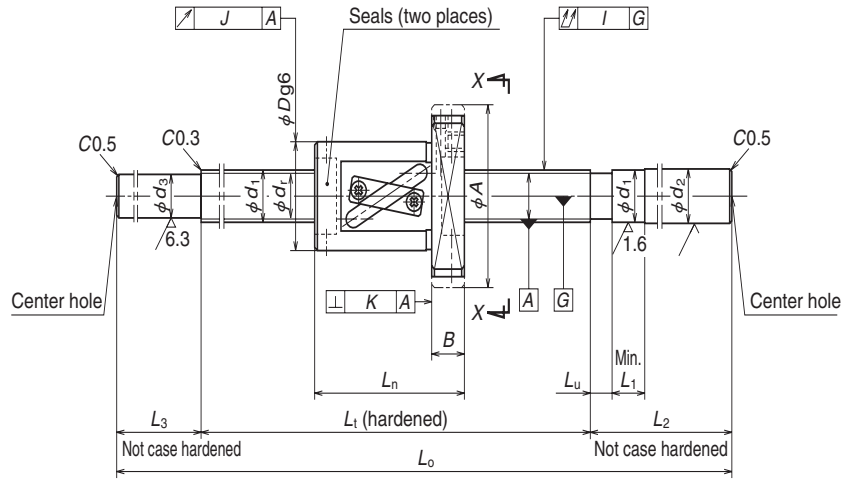

Nut type code: SFT, LSFT

Nut models: SFT, LSFT

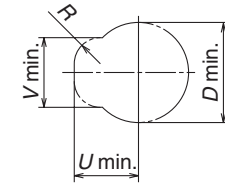
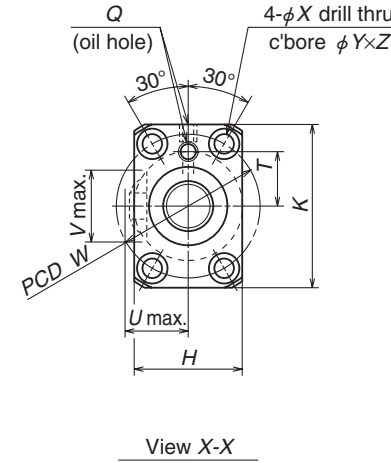

Housing hole and its clearance
(only applicable to shaft dia. φ16, lead 16)

NSK

Screw shaft ø16

Lead 5, 16

Screw shaft ø20

Lead 10, 20

Ball screw No.	Stroke Max. L _t -L _n	Screw shaft dia. d ₁	Lead l	Ball dia. D _w	Ball circle dia. d _m	Root dia. d _r	Effective ball turns x Circuits	Basic load rating (N)		Axial play Max.	Nut											
								Dynamic C _a	Static C _{0a}		Outside dia.	Flange					Overall length L _n	Bolt hole				
												D	A	H	K	B		L _n	W	X	Y	Z
W1605FS-1-C3T5	458	16	5	3.175	16.5	13.2	2.5x1	7 330	13 500	0.005	40	63	40	55	11	42	51	5.5	9.5	5.5		
W1609FS-1-C3T5	858										54	57	34	50	12	56	45	5.5	9.5	5.5		
W1606FS-1-C5T16	544	16	16	3.175	16.75	13.4	1.5x1	4 710	8 110	0.005	34	57	34	50	12	56	45	5.5	9.5	5.5		
W1611FS-1-C5T16	1 044										34	57	34	50	12	56	45	5.5	9.5	5.5		
W2009FS-1-C5T10	846	20	10	3.969	21	16.9	2.5x1	10 900	21 700	0.005	46	74	46	66	13	54	59	6.6	11	6.5		
W2013FS-1-C5T10	1 246										46	74	46	66	13	54	59	6.6	11	6.5		
W2010FS-1-C5T20	937	20	20	3.969	21	16.9	1.5x1	7 040	12 700	0.005	46	74	46	66	13	63	59	6.6	11	6.5		
W2015FS-1-C5T20	1 437										46	74	46	66	13	63	59	6.6	11	6.5		

- Notes: 1. Use of NSK support unit is recommended. See page B389 for details.
 2. Only rust preventive agent is applied at time of delivery. Please apply lubricant (oil or grease) before use. See page D13 for details.
 3. The permissible rotational speed is determined by d-n value, critical speed, and maximum rotational speed. See B299 and B47. The permissible rotational speed shown in the table is the value when the ball screw mounting method is Fixed-Fixed.

Unit: mm

dimensions			Screw shaft dimensions					Lead accuracy		Run-out			Mass (kg)	Permissible rotational speed N (min ⁻¹)	Internal spatial volume of nut (cm ³)	Standard volume of grease replenishing (cm ³)						
Projecting tube	Oil hole		Threaded length	Shaft end, right			Shaft end, left	Overall length	Deviation	Variation	Shaft straightness	Nut O.D. eccentricity					Flange perpendicularity					
U	V	R	Q	T	L _t	d ₂	L _u	L ₁	L ₂	d ₃	L ₃	L ₀	T	e _p	v _u	I	J	K				
—	—	—	M6x1	17	500	16.2	5	40	150	13.2	60	710	0	0.015	0.010	0.055	0.012	0.008	1.4	3 000	2.6	1.3
—	—	—	M6x1	17	900	16.2	5	40	150	13.2	60	1 110	0	0.021	0.015	0.095	0.015	0.011	1.9			
19	20	8	M6x1	17	600	16.2	10	40	150	13.4	60	810	0	0.030	0.023	0.085	0.015	0.011	1.5	3 000	2.1	1.1
—	—	—	M6x1	17	1 100	16.2	10	40	150	13.4	60	1 310	0	0.046	0.030	0.150	0.015	0.011	2.3			
—	—	—	M6x1	24	900	20.2	10	60	150	16.9	80	1 130	0	0.040	0.027	0.110	0.015	0.011	3.2	3 000	4.7	2.4
—	—	—	M6x1	24	1 300	20.2	10	60	150	16.9	80	1 530	0	0.054	0.035	0.150	0.015	0.011	4.1			
—	—	—	M6x1	24	1 000	20.2	13	60	150	16.9	80	1 230	0	0.040	0.027	0.110	0.015	0.011	3.6	3 000	4.2	2.1
—	—	—	M6x1	24	1 500	20.2	13	60	150	16.9	80	1 730	0	0.054	0.035	0.200	0.015	0.011	4.8			

Blank shaft end FS type

(Medium, High helix, Ultra high helix lead: End cap type)

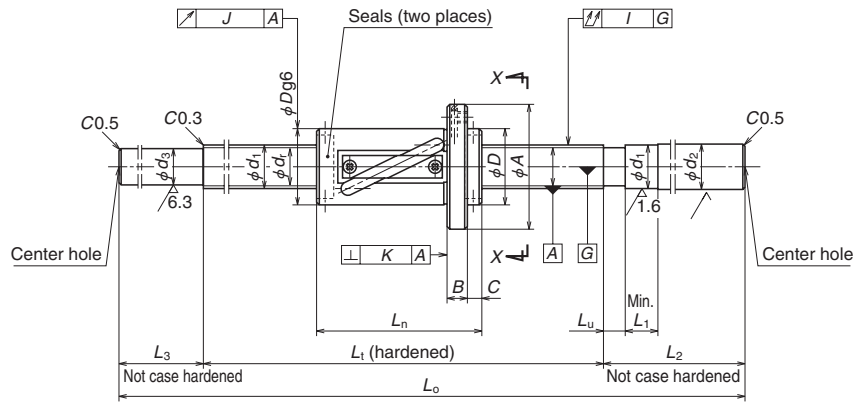

Nut type code: LSFT

Nut models: LSFT, USFC



Screw shaft ø25

Lead 20, 25, 50

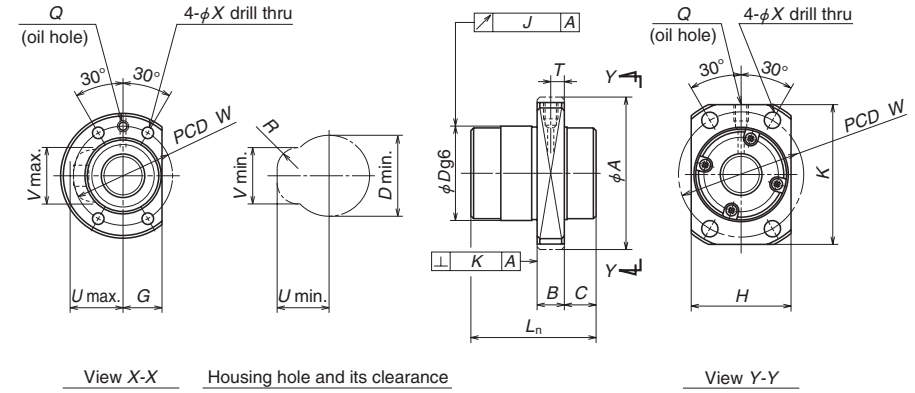

Nut type code: USFC

Ball screw No.	Stroke Max. L _t -L _n	Screw shaft dia. d _t	Lead l	Ball dia. D _w	Ball circle dia. d _m	Root dia. d _r	Effective ball turns × Circuits	Basic load rating (N)		Axial play Max.	Nut										
								Dynamic C _a	Static C _{0a}		Flange						Overall length L _n	Bolt hole W X			
											D	A	G	H	K	B			C		
W2513FS-1-C5T20	1 254	25	20	4.762	26.25	21.3	2.5x1	15 700	32 800	0.005	LSFT	44	71	23	—	—	12	8	96	57	6.6
W2521FS-1-C5T20	2 054																				
W2513FS-2-C5T25	1 260	25	25	4.762	26.25	21.3	1.5x1	10 100	19 100	0.005	LSFT	44	71	23	—	—	12	10	90	57	6.6
W2521FS-2-C5T25	2 060																				
W2515FS-1GX-C5T50	1 450	25	50	3.969	26	21.9	0.7x2	6 700	13 500	0.005	USFC	46	70	—	48	63	12	13	50	58	6.6
W2521FS-3GX-C5T50	2 100																				

- Notes: 1. Use of NSK support unit is recommended. See page B389 for details.
 2. Only rust preventive agent is applied at time of delivery. Please apply lubricant (oil or grease) before use. See page D13 for details.
 3. The permissible rotational speed is determined by d-n value, critical speed, and maximum rotational speed. See B299 and B47. The permissible rotational speed shown in the table is the value when the ball screw mounting method is Fixed-Fixed.

dimensions		Screw shaft dimensions						Lead accuracy		Run-out			Mass (kg)	Permissible rotational speed N (min ⁻¹)	Internal spatial volume of nut (cm ³)	Standard volume of grease replenishing (cm ³)						
Projecting tube	Oil hole	Threaded length	Shaft end, right	Shaft end, left	Overall length	Deviation	Variation	Shaft straightness	Nut O.D. eccentricity	Flange perpendicularity												
U	V R	Q T	L _t d ₂ L _u L ₁ L ₂ d ₃ L ₃ L ₀	T	e _p	v _u	I	J	K													
31	35	12	M6x1	—	1 350 2 150	25.2	13	70	200	21.3	100	1 650 2 450	0	0.054 0.077	0.035 0.046	0.120 0.160	0.015	0.011	6.8 9.8	2 550 1 000	12	6.0
32	34	12	M6x1	—	1 350 2 150	25.2	15	70	200	21.3	100	1 650 2 450	0	0.054 0.077	0.035 0.046	0.120 0.160	0.015	0.011	6.8 9.8	2 540 1 000	10	5.0
—	—	—	M6x1	6	1 500 2 150	25.2	26	70	200	21.9	100	1 800 2 450	0	0.054 0.077	0.035 0.046	0.120 0.160	0.015	0.011	7.3 9.8	1 250 1 000	5.3	2.7

Unit: mm

Blank shaft end FS type

(Medium, High helix lead: Tube type)

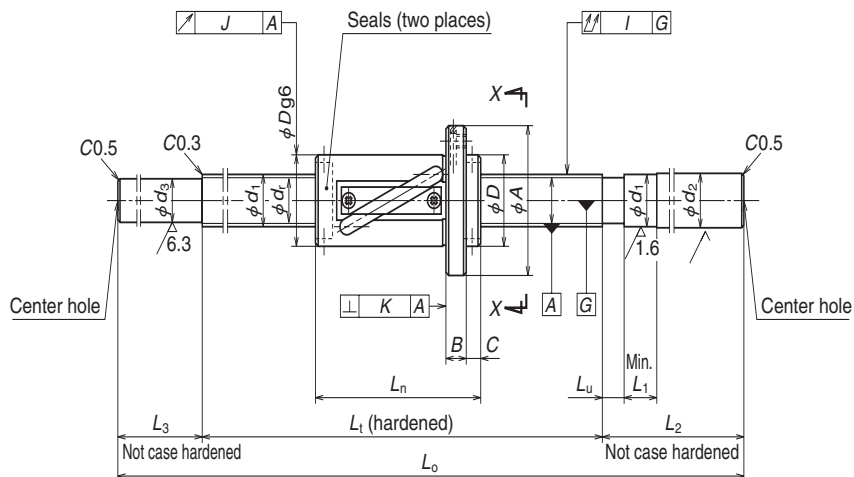

Nut type code: LSFT

Nut model: LSFT

NSK

Screw shaft ø32

Lead 25, 32

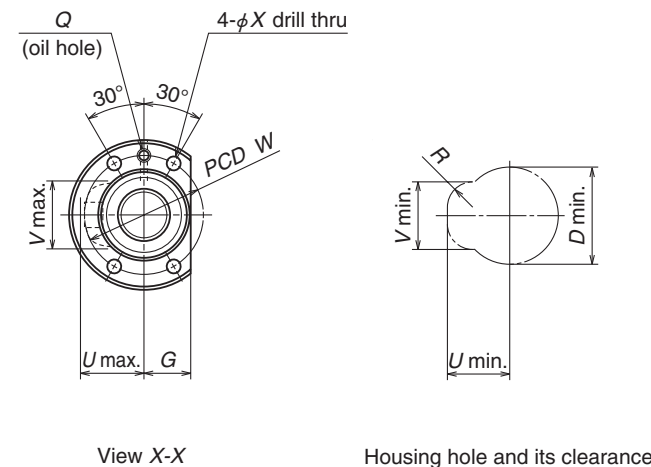

Ball screw No.	Stroke Max. L _r -L _n	Screw shaft dia. d ₁	Lead l	Ball dia. D _w	Ball circle dia. d _m	Root dia. d _r	Effective ball turns Turns x Circuits	Basic load rating (N)		Axial play Max.	Nut							
								Dynamic C _a	Static C _{0a}		Outside dia. D	Flange				Overall length L _n	Bolt hole W X	
												A	G	B	C			
W3217FS-1-C5T25	1 583	32	25	4.762	33.25	28.3	2.5x1	17 900	41 800	0.005	51	85	26	15	10	117	67	9
W3227FS-1-C5T25	2 583																	
W3217FS-2-C5T32	1 591	32	32	4.762	33.25	28.3	1.5x1	11 500	24 800	0.005	51	85	26	15	12	109	67	9
W3227FS-2-C5T32	2 591																	

- Notes: 1. Use of NSK support unit is recommended. See page B389 for details.
 2. Only rust preventive agent is applied at time of delivery. Please apply lubricant (oil or grease) before use. See page D13 for details.
 3. The permissible rotational speed is determined by d-n value, critical speed, and maximum rotational speed. See B299 and B47. The permissible rotational speed shown in the table is the value when the ball screw mounting method is Fixed-Fixed.

dimensions		Screw shaft dimensions					Lead accuracy			Run-out			Mass (kg)	Permissible rotational speed (min ⁻¹)	Internal spatial volume of nut (cm ³)	Standard volume of grease replenishing (cm ³)					
Projecting tube	Oil hole	Threaded length	Shaft end, right			Shaft end, left		Overall length	Lead deviation	Lead variation	Shaft straightness	Nut O.D. eccentricity					Flange perpendicularity				
U	V	R	Q	L _r	d ₂	L _u	L ₁	L ₂	d ₃	L ₃	L ₀	T	e _p	v _u	I	J	K				
34	42	12	M6x1	1 700	32.3	15	70	250	28.3	120	2 070	0	0.065	0.040	0.160	0.019	0.013	13.8	2 180	17	8.5
				2 700							3 070		0.093	0.054	0.210			20.0	800		
34	42	12	M6x1	1 700	32.3	19	70	250	28.3	120	2 070	0	0.065	0.040	0.160	0.019	0.013	13.9	2 180	15	7.5
				2 700							3 070		0.093	0.054	0.210			20.0	790		

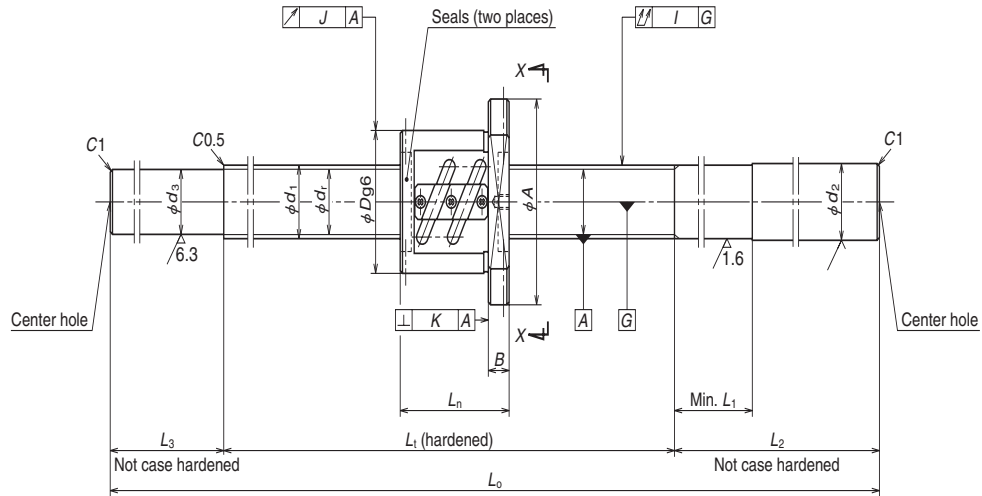

Nut type code: PFT

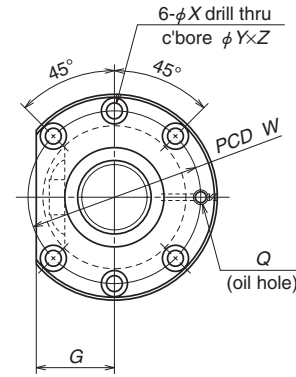

View X-X

Ball screw No.	Stroke Max. L_r-L_n	Screw shaft dia. d_1	Lead l	Ball dia. D_w	Ball circle dia. d_m	Root dia. d_r	Effective ball turns x Circuits	Basic load rating (N)		Preload (N)	Dynamic friction torque median (N·cm)	Nut						
								Dynamic C_a	Static C_{0a}			Outside dia. D	Flange			Overall length L_n	Bolt hole W	X
													A	G	B			
W2003SS-1P-C5Z4	251	20	4	2.381	20.3	17.8	2.5x2	5 420	10 700	290	3.9	40	63	24	11	49	51	5.5
W2005SS-1P-C5Z4	451																	
W2008SS-1P-C5Z4	751																	
W2003SS-2P-C5Z5	244	20	5	3.175	20.5	17.2	2.5x2	9 410	17 100	490	7.8	44	67	26	11	56	55	5.5
W2005SS-2P-C5Z5	444																	
W2007SS-1P-C5Z5	644																	
W2010SS-1P-C5Z5	944																	

- Notes: 1. Use of NSK support unit is recommended. See page B389 for details.
 2. Only rust preventive agent is applied at time of delivery. Please apply lubricant (oil or grease) before use. See page D13 for details.
 3. The permissible rotational speed is determined by d-n value, critical speed, and maximum rotational speed. See B299 and B47. The permissible rotational speed shown in the table is the value when the ball screw mounting method is Fixed-Fixed.

Unit: mm

dimensions		Screw shaft dimensions						Lead accuracy			Run-out			Mass (kg)	Permissible rotational speed N (min ⁻¹)	Internal spatial volume of nut (cm ³)	Standard volume of grease replenishing (cm ³)			
Bolt hole Y	Oil hole Z	Threaded length L_t	Shaft end, right d_2	Shaft end, left d_3	Overall length L_0	Travel compensation T	Deviation e_p	Variation v_u	Shaft straightness I	Nut O.D. eccentricity J	Flange perpendicularity K									
9.5	5.5	M6x1	300	20.2	40	150	17.8	—	450	-0.007	0.023	0.018	0.055	0.015	0.011	1.5	3 000	2.7	1.4	
			500			150		50	700	-0.012	0.027	0.020	0.085							2.0
			800			200		100	1 100	-0.019	0.035	0.025	0.140							2.9
9.5	5.5	M6x1	300	20.2	40	150	17.2	—	450	-0.007	0.023	0.018	0.055	0.015	0.011	1.6	3 000	4.3	2.2	
			500			150		50	700	-0.012	0.027	0.020	0.085							2.2
			700			200		100	1 000	-0.017	0.035	0.025	0.110							2.8
			1 000			200		100	1 300	-0.024	0.040	0.027	0.180							3.5

Blank shaft end SS type

(Fine lead: Tube type)

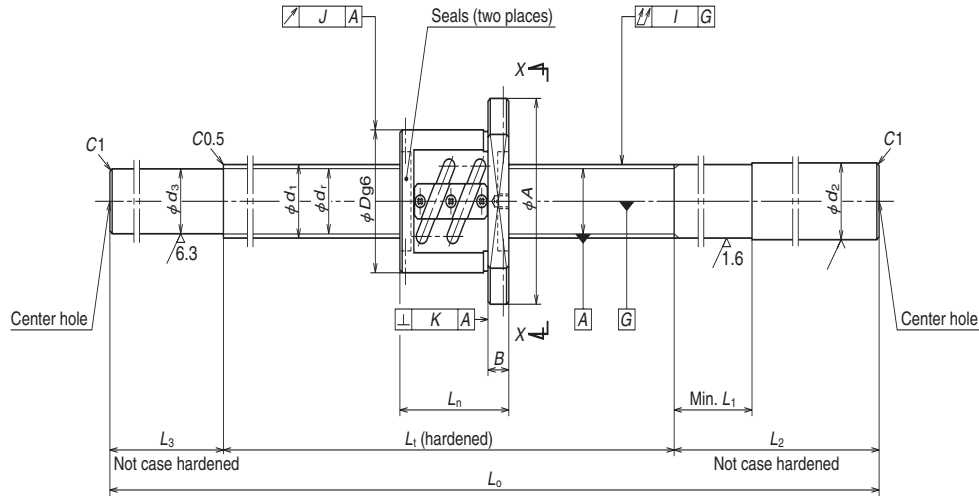

Nut type code: PFT

Nut model: PFT

NSK

Screw shaft ø25

Lead 4, 5, 6

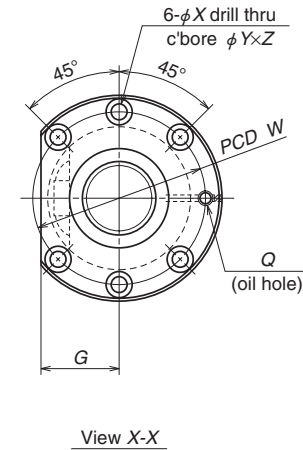

Ball screw No.	Stroke Max. L_r-L_n	Screw shaft dia. d_1	Lead l	Ball dia. D_w	Ball circle dia. d_m	Root dia. d_r	Effective ball turns x Circuits	Basic load rating (N)		Preload (N)	Dynamic friction torque, median (N·cm)	Nut						
								Dynamic C_a	Static C_{0a}			Outside dia. D	Flange		Overall length L_n	Bolt hole		
													A	G		B	L_1	W
W2503SS-1P-C5Z4	252							6 020	13 600	290	4.9	46	69	26	11	48	57	5.5
W2506SS-1P-C5Z4	552	25	4	2.381	25.3	22.8	2.5x2	6 020	13 600	290	4.9	46	69	26	11	48	57	5.5
W2510SS-1P-C5Z4	952																	
W2503SS-2P-C5Z5	245																	
W2505SS-1P-C5Z5	445	25	5	3.175	25.5	22.2	2.5x2	10 400	21 900	540	8.8	50	73	28	11	55	61	5.5
W2508SS-1P-C5Z5	745																	
W2512SS-1P-C5Z5	1 145																	
W2504SS-1P-C5Z6	338																	
W2508SS-2P-C5Z6	738	25	6	3.969	25.5	21.4	2.5x2	14 100	26 800	690	13.8	53	76	29	11	62	64	5.5
W2512SS-2P-C5Z6	1 138																	

- Notes: 1. Use of NSK support unit is recommended. See page B389 for details.
 2. Only rust preventive agent is applied at time of delivery. Please apply lubricant (oil or grease) before use. See page D13 for details.
 3. The permissible rotational speed is determined by d-n value, critical speed, and maximum rotational speed. See B299 and B47. The permissible rotational speed shown in the table is the value when the ball screw mounting method is Fixed-Fixed.

dimensions		Screw shaft dimensions						Lead accuracy			Run-out			Mass (kg)	Permissible rotational speed N (min ⁻¹)	Internal spatial volume of nut (cm ³)	Standard volume of grease replenishing (cm ³)				
Bolt hole	Oil hole	Threaded length	Shaft end, right	Shaft end, left	Overall length	Travel compensation	Deviation	Variation	Shaft straightness	Nut O.D. eccentricity	Flange perpendicularity										
Y	Z	Q	L_1	d_2	L_1	L_2	d_3	L_3	L_0	T	e_p	v_u	I	J	K						
9.5	5.5	M6x1	300	25.2	40	150	—	—	450	-0.007	0.023	0.018	0.040	0.015	0.011	2.2	2 800	3.2	1.6		
			600			200	22.8	100	900	-0.014	0.030	0.023	0.075			3.8					
			1 000			200		100	1 300	-0.024	0.040	0.027	0.120			5.2					
9.5	5.5	M6x1	300	25.2	40	200	—	—	500	-0.007	0.023	0.018	0.040	0.015	0.011	2.5	2 800	5.2	2.6		
			500			200	22.2	50	750	-0.012	0.027	0.020	0.060								3.4
			800			250		100	1 150	-0.019	0.035	0.025	0.090								4.8
			1 200			300		100	1 600	-0.029	0.046	0.030	0.120			6.3					
9.5	5.5	M6x1	400	25.2	40	200	—	—	600	-0.010	0.025	0.020	0.050	0.019	0.013	3.0	2 800	7.0	3.5		
			800			250	21.4	100	1 150	-0.019	0.035	0.025	0.090								4.8
			1 200			300		100	1 600	-0.029	0.046	0.030	0.120								6.3

Blank shaft end SS type

(Fine lead: Deflector (bridge) type)

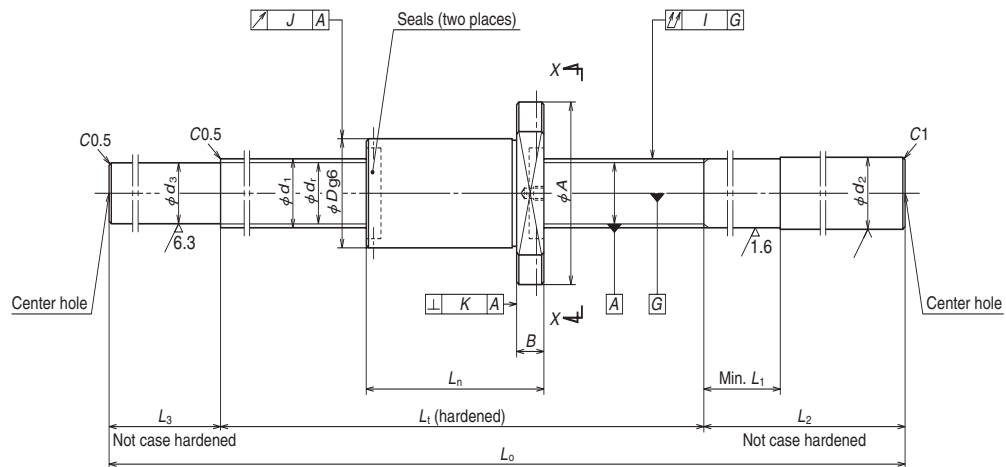

Nut type code: ZFD

Nut model: ZFD

NSK

Screw shaft ø25

Lead 5, 10

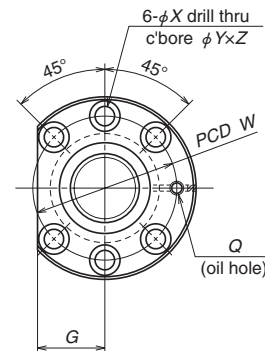

View X-X

Ball screw No.	Stroke Max. L_1-L_n	Screw shaft dia. d_1	Lead l	Ball dia. D_w	Ball circle dia. d_m	Root dia. d_r	Effective ball turns x Circuits	Basic load rating (N)		Preload (N)	Dynamic friction torque, median (N·cm)	Nut						
								Dynamic C_a	Static C_{0a}			Outside dia. D	Flange			Overall length L_n	Bolt hole W	X
													A	G	B			
W2502SS-1ZY-C5Z5	184	25	5	3.175	25.75	22.4	1x3	9 790	22 900	740	13.8	40	63	24	11	66	51	5.5
W2504SS-3ZY-C5Z5	334																	
W2506SS-2ZY-C5Z5	534																	
W2509SS-1ZY-C5Z5	834																	
W2512SS-3ZY-C5Z5	1 134																	
W2504SS-4ZY-C5Z10	312	25	10	4.762	26.25	21.3	1x2	11 400	21 400	880	21.5	42	69	26	15	88	55	6.6
W2506SS-3ZY-C5Z10	512																	
W2508SS-3ZY-C5Z10	712																	
W2511SS-1ZY-C5Z10	1 012																	
W2515SS-2ZY-C5Z10	1 412																	

- Notes: 1. Use of NSK support unit is recommended. See page B389 for details.
 2. Only rust preventive agent is applied at time of delivery. Please apply lubricant (oil or grease) before use. See page D13 for details.
 3. The permissible rotational speed is determined by d-n value, critical speed, and maximum rotational speed. See B299 and B47. The permissible rotational speed shown in the table is the value when the ball screw mounting method is Fixed-Fixed.

dimensions		Screw shaft dimensions						Lead accuracy			Run-out			Mass (kg)	Permissible rotational speed N (min ⁻¹)	Internal spatial volume of nut (cm ³)	Standard volume of grease replenishing (cm ³)		
Bolt hole Y	Oil hole Z	Threaded length L_t	Shaft end, right d_2	Shaft end, left d_3	Overall length L_o	Travel compensation T	Deviation e_p	Variation v_u	Shaft straightness I	Nut O.D. eccentricity J	Flange perpendicularity K								
9.5	5.5	M6x1	250	25.2	40	200	—	450	-0.005	0.023	0.018	0.040	0.015	0.011	2.1	2 800	5.4	2.7	
			400			200	50	650	-0.009	0.025	0.020	0.060							2.8
			600			250	100	950	-0.013	0.030	0.023	0.075							3.9
			900			250	100	1 250	-0.021	0.040	0.027	0.090							4.9
			1 200			300	100	1 600	-0.028	0.046	0.030	0.120							6.2
11	6.5	M6x1	400	25.2	60	200	50	650	-0.008	0.025	0.020	0.060	0.015	0.011	3.0	2 800	9.0	4.5	
			600			250	100	950	-0.012	0.030	0.023	0.075							4.1
			800			250	100	1 150	-0.017	0.035	0.025	0.090							4.8
			1 100			300	100	1 500	-0.024	0.046	0.030	0.120							6.0
			1 500			300	100	1 900	-0.034	0.054	0.035	0.150							7.4

Blank shaft end SS type

(Fine lead: Tube type)

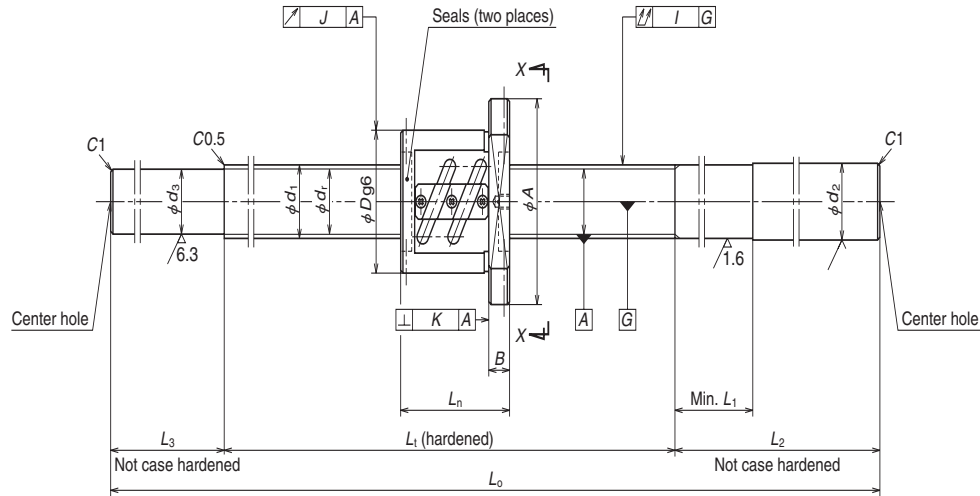

Nut type code: PFT

Nut model: PFT

NSK

Screw shaft ø25

Lead 10

Screw shaft ø28

Lead 5, 6

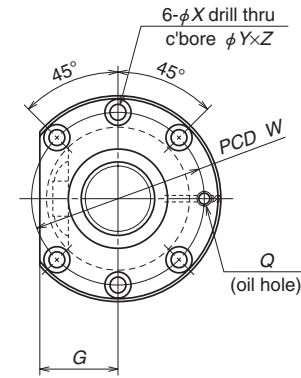

View X-X

Unit: mm

Ball screw No.	Stroke Max. L_r-L_n	Screw shaft dia. d_1	Lead l	Ball dia. D_w	Ball circle dia. d_m	Root dia. d_r	Effective ball turns Turns x Circuits	Basic load rating (N)		Preload (N)	Dynamic friction torque, median (N·cm)	Nut						
								Dynamic C_a	Static C_{0a}			Outside dia. D	Flange		Overall length L_n	Bolt hole W	X	
													A	G				B
W2504SS-2P-C5Z10	319	25	10	4.762	25.5	20.5	1.5x2	11 600	19 000	590	13.8	58	85	32	15	81	71	6.6
W2507SS-1P-C5Z10	619																	
W2510SS-2P-C5Z10	919																	
W2515SS-1P-C5Z10	1 419																	
W2804SS-1P-C5Z5	344	28	5	3.175	28.5	25.2	2.5x2	11 000	24 400	540	9.8	55	85	31	12	56	69	6.6
W2806SS-1P-C5Z5	544																	
W2808SS-1P-C5Z5	744																	
W2812SS-1P-C5Z5	1 144																	
W2804SS-3P-C5Z6	337	28	6	3.175	28.5	25.2	2.5x2	11 000	24 400	540	10.8	55	85	31	12	63	69	6.6
W2806SS-3P-C5Z6	537																	
W2808SS-3P-C5Z6	737																	
W2812SS-3P-C5Z6	1 137																	

- Notes: 1. Use of NSK support unit is recommended. See page B389 for details.
 2. Only rust preventive agent is applied at time of delivery. Please apply lubricant (oil or grease) before use. See page D13 for details.
 3. The permissible rotational speed is determined by d-n value, critical speed, and maximum rotational speed. See B299 and B47. The permissible rotational speed shown in the table is the value when the ball screw mounting method is Fixed-Fixed.

dimensions		Screw shaft dimensions						Lead accuracy			Run-out			Mass (kg)	Permissible rotational speed N (min ⁻¹)	Internal spatial volume of nut (cm ³)	Standard volume of grease replenishing (cm ³)	
Bolt hole Y	Oil hole Z	Threaded length L_t	Shaft end, right		Shaft end, left		Overall length L_o	Travel compensation T	Deviation e_p	Variation v_u	Shaft straightness I	Nut O.D. eccentricity J	Flange perpendicularity K					
			d_2	L_1	L_2	d_3												L_3
11	6.5	M6x1	400	25.2	60	20.5	50	650	-0.10	0.025	0.020	0.060	0.019	0.013	3.8	2 800	9.7	4.9
			700				1 050	-0.17	0.035	0.025	0.090	5.1						
			1 000				1 350	-0.24	0.040	0.027	0.120	6.1						
			1 500				1 900	-0.36	0.054	0.035	0.150	8.0						
11	6.5	M6x1	400	28.2	40	25.2	—	600	-0.10	0.025	0.020	0.050	0.019	0.013	3.7	2 500	6.1	3.1
			600				950	-0.14	0.030	0.023	0.075	5.2						
			800				1 150	-0.19	0.035	0.025	0.090	6.1						
			1 200				1 600	-0.29	0.046	0.030	0.120	8.1						
11	6.5	M6x1	400	28.2	40	25.2	—	600	-0.10	0.025	0.020	0.050	0.019	0.013	3.8	2 500	6.1	3.1
			600				950	-0.14	0.030	0.023	0.075	5.3						
			800				1 150	-0.19	0.035	0.025	0.090	6.2						
			1 200				1 600	-0.29	0.046	0.030	0.120	8.2						

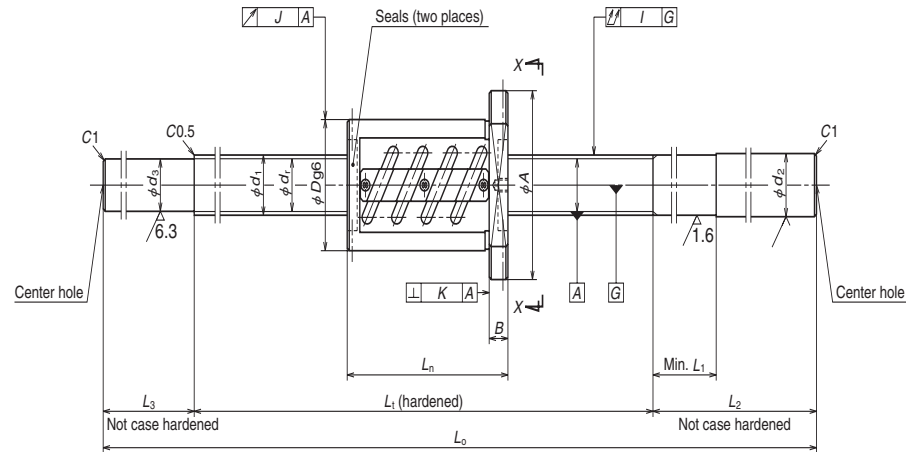

Nut type code: ZFT

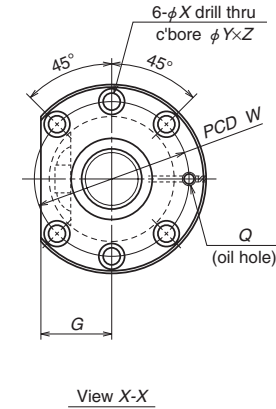

View X-X

Unit: mm

Ball screw No.	Stroke Max. L_1-L_n	Screw shaft dia. d_1	Lead l	Ball dia. D_w	Ball circle dia. d_m	Root dia. d_r	Effective ball turns x Circuits	Basic load rating (N)		Preload (N)	Dynamic friction torque median (N·cm)	Nut						
								Dynamic C_a	Static C_{0a}			Outside dia. D	Flange		Overall length L_n	Bolt hole W	X	
													A	G				B
W2804SS-2Z-C5Z5	314	28	5	3.175	28.5	25.2	2.5x2	17 400	48 800	1 225	21.5	55	85	31	12	86	69	6.6
W2806SS-2Z-C5Z5	514																	
W2808SS-2Z-C5Z5	714																	
W2812SS-2Z-C5Z5	1 114																	
W2804SS-4Z-C5Z6	301	28	6	3.175	28.5	25.2	2.5x2	17 400	48 800	1 225	22.5	55	85	31	12	99	69	6.6
W2806SS-4Z-C5Z6	501																	
W2808SS-4Z-C5Z6	701																	
W2812SS-4Z-C5Z6	1 101																	

dimensions			Screw shaft dimensions						Lead accuracy			Run-out			Mass (kg)	Permissible rotational speed (N/min ⁻¹)	Internal spatial volume of nut (cm ³)	Standard volume of grease replenishing (cm ³)	
Bolt hole Y	Oil hole Z	Q	Threaded length L_1	Shaft end, right		Shaft end, left		Overall length L_0	Travel compensation T	Deviation e_p	Variation v_u	Shaft straightness I	Nut O.D. eccentricity J	Flange perpendicularity K					
				d_2	L_1	L_2	d_3												L_3
11	6.5	M6x1	400	28.2	40	250	25.2	—	600	-0.010	0.025	0.020	0.050	0.019	0.013	4.7	2 500	9.2	4.6
			600					100	950	-0.014	0.030	0.023	0.075			5.5			
			800					100	1 150	-0.019	0.035	0.025	0.090			6.4			
			1 200					100	1 600	-0.029	0.046	0.030	0.120			8.4			
11	6.5	M6x1	400	28.2	40	250	25.2	—	600	-0.010	0.025	0.020	0.050	0.019	0.013	4.2	2 500	9.5	4.8
			600					100	950	-0.014	0.030	0.023	0.075			5.7			
			800					100	1 150	-0.019	0.035	0.025	0.090			6.6			
			1 200					100	1 600	-0.029	0.046	0.030	0.120			8.6			

- Notes: 1. Use of NSK support unit is recommended. See page B389 for details.
 2. Only rust preventive agent is applied at time of delivery. Please apply lubricant (oil or grease) before use. See page D13 for details.
 3. The permissible rotational speed is determined by d-n value, critical speed, and maximum rotational speed. See B299 and B47. The permissible rotational speed shown in the table is the value when the ball screw mounting method is Fixed-Fixed.

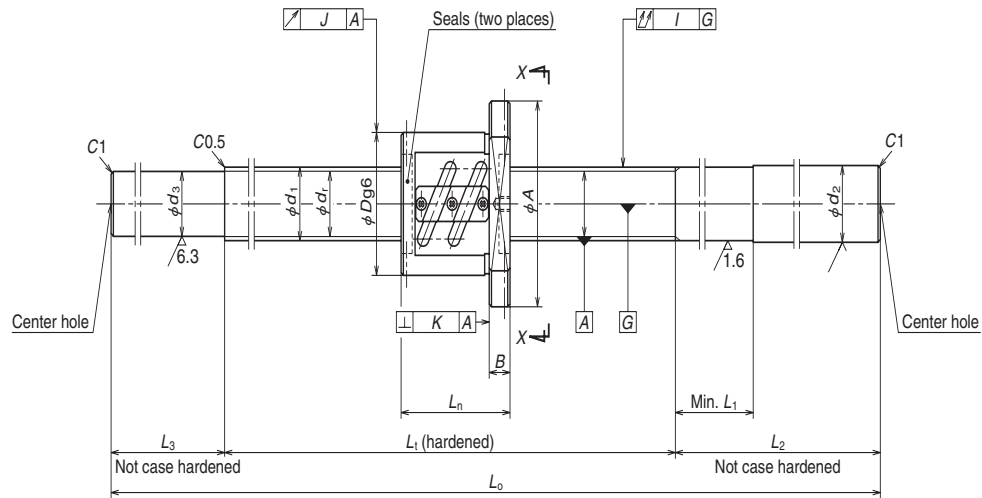

Nut type code: PFT

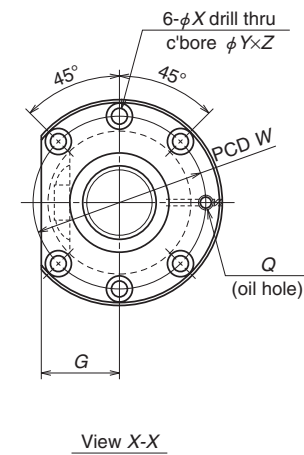

View X-X

Unit: mm

Ball screw No.	Stroke Max. L_r-L_n	Screw shaft dia. d_1	Lead l	Ball dia. D_w	Ball circle dia. d_m	Root dia. d_r	Effective ball turns \times Circuits	Basic load rating (N)		Preload (N)	Dynamic friction torque, median (N-cm)	Nut				
								Dynamic C_a	Static C_{oa}			Outside dia. D	Flange		Overall length L_n	
													A	G		B
W3204SS-1P-C5Z5	344	32	5	3.175	32.5	29.2	2.5×2	11 600	28 000	590	10.8	58	85	32	12	56
W3206SS-1P-C5Z5	544															
W3208SS-1P-C5Z5	744															
W3212SS-1P-C5Z5	1 144															
W3215SS-1P-C5Z5	1 444															
W3206SS-3P-C5Z6	537	32	6	3.969	32.5	28.4	2.5×2	15 500	34 700	780	15.6	62	89	34	12	63
W3210SS-1P-C5Z6	937															
W3215SS-3P-C5Z6	1 437															

- Notes: 1. Use of NSK support unit is recommended. See page B389 for details.
 2. Only rust preventive agent is applied at time of delivery. Please apply lubricant (oil or grease) before use. See page D13 for details.
 3. The permissible rotational speed is determined by d-n value, critical speed, and maximum rotational speed. See B299 and B47. The permissible rotational speed shown in the table is the value when the ball screw mounting method is Fixed-Fixed.

dimensions				Screw shaft dimensions					Lead accuracy			Run-out			Mass (kg)	Permissible rotational speed (min ⁻¹)	Internal spatial volume of nut (cm ³)	Standard volume of grease replenishing (cm ³)									
Bolt hole		Oil hole		Threaded length L_1	Shaft end, right		Shaft end, left		Overall length L_0	Travel compensation T	Deviation e_p	Variation v_u	Shaft straightness I	Nut O.D. eccentricity J					Flange perpendicularity K								
W	X	Y	Z		Q	L_1	L_2	d_3												L_3							
71	6.6	11	6.5	M6×1	400	32.3	40	200	29.2	50	650	-0.010	0.025	0.020	0.060	0.019	0.013	4.8	2 180	6.9	3.5						
					600			250		100												950	-0.014	0.030	0.023	0.075	6.5
					800			250		100												1 150	-0.019	0.035	0.025	0.090	7.7
					1 200			300		100												1 600	-0.029	0.046	0.030	0.120	10.3
					1 500			300		100												1 900	-0.036	0.054	0.035	0.150	12.1
75	6.6	11	6.5	M6×1	600	32.3	40	250	28.4	950	1 400	-0.014	0.030	0.023	0.075	0.019	0.013	6.7	2 180	9.4	4.7						
					1 000			300		1 400												-0.024	0.040	0.027	0.120	9.2	
					1 500			300		1 900												-0.036	0.054	0.035	0.150	12.1	

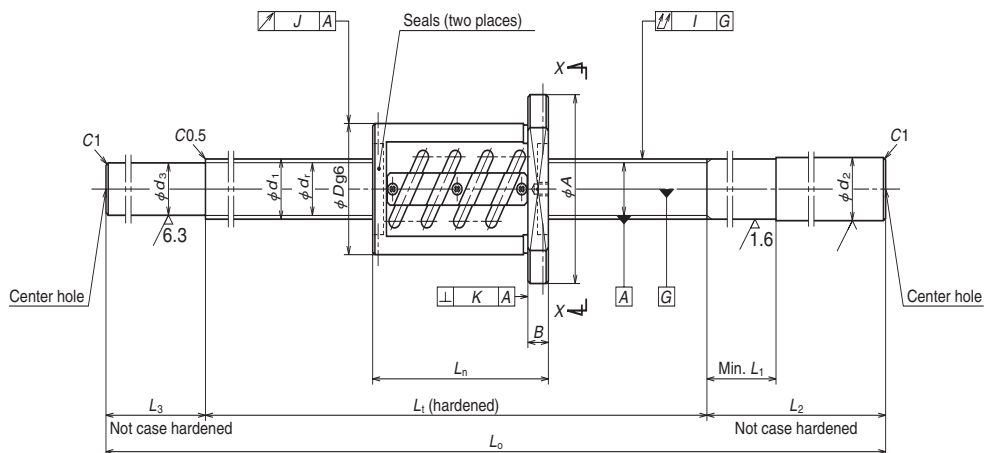

Nut type code: ZFT

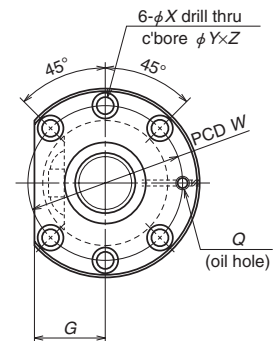

View X-X

Unit: mm

Ball screw No.	Stroke Max. L _r -L _n	Screw shaft dia. d ₁	Lead l	Ball dia. D _w	Ball circle dia. d _m	Root dia. d _r	Effective ball turns × Circuits	Basic load rating (N)			Dynamic friction torque, median (N·cm)	Nut				
								Dynamic C _a	Static C _{0a}	Preload (N)		Flange				Overall length L _n
												Outside dia. D	A	G	B	
W3204SS-2Z-C5Z5	314	32	5	3.175	32.5	29.2	2.5×2	18 500	56 100	1 270	22.5	58	85	32	12	86
W3206SS-2Z-C5Z5	514															
W3208SS-2Z-C5Z5	714															
W3212SS-2Z-C5Z5	1 114															
W3215SS-2Z-C5Z5	1 414															
W3206SS-4Z-C5Z6	501	32	6	3.969	32.5	28.4	2.5×2	24 700	69 400	1 720	34.5	62	89	34	12	99
W3210SS-2Z-C5Z6	901															
W3215SS-4Z-C5Z6	1 401															
W3206SS-5Z-C5Z8	518	32	8	4.762	32.5	27.5	2.5×1	17 500	41 000	1 320	30.5	66	100	38	15	82
W3210SS-3Z-C5Z8	918															
W3215SS-5Z-C5Z8	1 418															

- Notes: 1. Use of NSK support unit is recommended. See page B389 for details.
 2. Only rust preventive agent is applied at time of delivery. Please apply lubricant (oil or grease) before use. See page D13 for details.
 3. The permissible rotational speed is determined by d-n value, critical speed, and maximum rotational speed. See B299 and B47. The permissible rotational speed shown in the table is the value when the ball screw mounting method is Fixed-Fixed.

dimensions				Screw shaft dimensions					Lead accuracy			Run-out			Mass (kg)	Permissible rotational speed N (min ⁻¹)	Internal spatial volume of nut (cm ³)	Standard volume of grease replenishing (cm ³)			
Bolt hole		Oil hole		Threaded length	Shaft end, right		Shaft end, left		Overall length	Travel compensation	Deviation	Variation	Shaft straightness	Nut O.D. eccentricity					Flange perpendicularity		
W	X	Y	Z	Q	L ₁	d ₂	L ₁	L ₂	d ₃	L ₃	L ₀	T	e _p	v _u					I	J	K
71	6.6	11	6.5	M6×1	400	32.3	40	250	29.2	50	650	-0.010	0.025	0.020	0.060	0.019	0.013	5.1	2 180	10	5.0
					600					100	950	-0.014	0.030	0.023	0.075			6.9			
					800					100	1 150	-0.019	0.035	0.025	0.090			8.0			
					1 200					100	1 600	-0.029	0.046	0.030	0.120			10.1			
					1 500					100	1 900	-0.036	0.054	0.035	0.150			12.4			
75	6.6	11	6.5	M6×1	600	32.3	40	300	28.4	—	950	-0.014	0.030	0.023	0.075	0.019	0.013	7.1	2 180	15	7.5
					1 000					100	1 400	-0.024	0.040	0.027	0.120			9.7			
					1 500					—	1 900	-0.036	0.054	0.035	0.150			12.6			
82	9	14	8.5	M6×1	600	32.3	50	300	27.5	—	950	-0.014	0.030	0.023	0.075	0.019	0.013	7.3	2 180	7.9	4.0
					1 000					100	1 400	-0.024	0.040	0.027	0.120			9.8			
					1 500					—	1 900	-0.036	0.054	0.035	0.150			12.6			

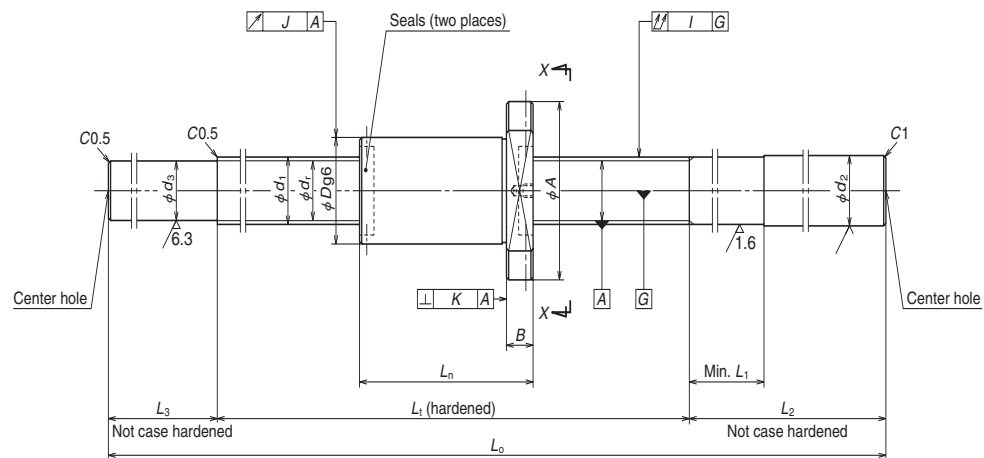

Nut type code: ZFD

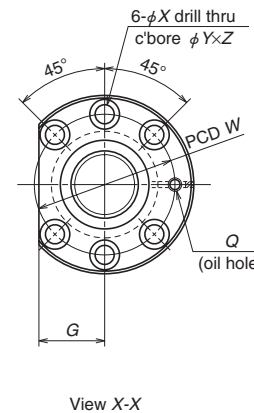

Ball screw No.	Stroke Max. L _r -L _n	Screw shaft dia. d ₁	Lead l	Ball dia. D _w	Ball circle dia. d _m	Root dia. d _r	Effective ball turns Turns × Circuits	Basic load rating (N)			Dynamic friction torque, median (N·cm)	Nut														
								Dynamic C _a	Static C _{0a}	Preload (N)		Flange				Overall length L _n										
												Outside dia. D	A	G	B											
W3204SS-3ZY-C5Z5	323																									
W3206SS-6ZY-C5Z5	523																									
W3209SS-1ZY-C5Z5	823	32	5	3.175	32.75	29.4	4	14 200	40 700	1 080	19.6	48	75	29	12	77										
W3212SS-3ZY-C5Z5	1 123																									
W3216SS-1ZY-C5Z5	1 523																									
W3205SS-3ZY-C5Z10	380																									
W3207SS-3ZY-C5Z10	580																									
W3210SS-6ZY-C5Z10	880	32	10	6.35	33.75	27.1	3	25 900	52 800	1 860	49.0	54	88	34	15	120										
W3214SS-3ZY-C5Z10	1 280																									
W3218SS-3ZY-C5Z10	1 680																									

- Notes: 1. Use of NSK support unit is recommended. See page B389 for details.
 2. Only rust preventive agent is applied at time of delivery. Please apply lubricant (oil or grease) before use. See page D13 for details.
 3. The permissible rotational speed is determined by d-n value, critical speed, and maximum rotational speed. See B299 and B47. The permissible rotational speed shown in the table is the value when the ball screw mounting method is Fixed-Fixed.

Unit: mm

dimensions				Screw shaft dimensions					Lead accuracy			Run-out			Mass (kg)	Permissible rotational speed (min ⁻¹)	Internal spatial volume of nut (cm ³)	Standard volume of grease replenishing (cm ³)		
Bolt hole		Oil hole		Threaded length	Shaft end, right		Shaft end, left		Overall length	Travel compensation	Deviation	Variation	Shaft straightness	Nut O.D. eccentricity					Flange perpendicularity	
W	X	Y	Z		Q	L ₁	d ₂	L ₁												L ₂
61	6.6	11	6.5	M6x1	32.3	40	250	29.4	50	650	-0.009	0.025	0.020	0.060	0.015	0.011	4.6	2 180	22	11
									60	950	-0.013	0.030	0.023	0.075			6.4			
									90	1 250	-0.021	0.040	0.027	0.090			8.1			
									1 200	1 600	-0.028	0.046	0.030	0.120			10.2			
									1 600	2 000	-0.037	0.054	0.035	0.150			12.6			
70	9	14	8.5	M6x1	32.3	60	250	27.1	100	850	-0.010	0.027	0.020	0.075	0.019	0.013	6.2	2 180	23	12
									70	1 050	-0.015	0.035	0.025	0.090			7.3			
									1 000	1 400	-0.022	0.040	0.027	0.120			9.3			
									1 400	1 870	-0.032	0.054	0.035	0.150			11.9			
									1 800	2 270	-0.041	0.065	0.040	0.200			14.1			

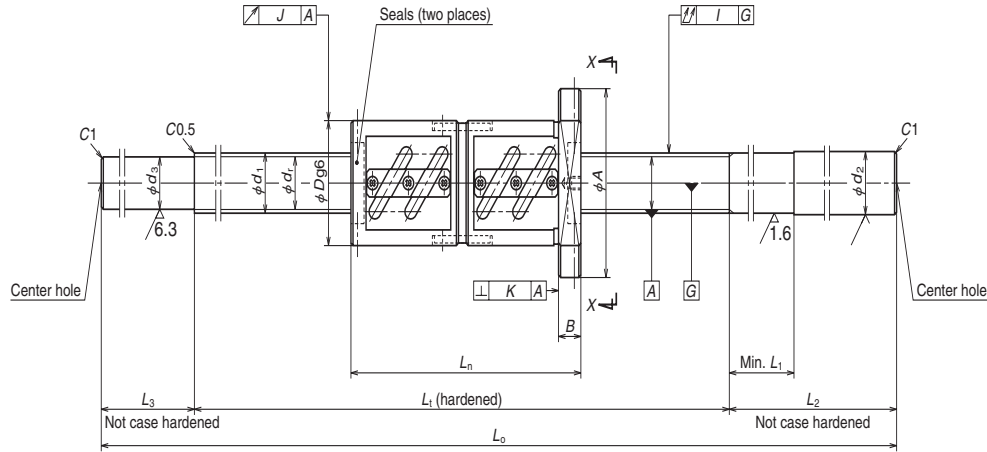

Nut type code: DFT

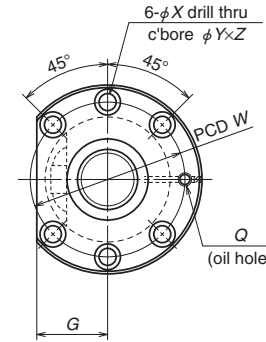

View X-X

Ball screw No.	Stroke Max. L _r -L _n	Screw shaft dia. d ₁	Lead l	Ball dia. D _w	Ball circle dia. d _m	Root dia. d _r	Effective ball turns × Circuits	Basic load rating (N)		Preload (N)	Dynamic friction torque, median (N·cm)	Nut				
								Dynamic C _a	Static C _{0a}			Flange				Overall length L _n
												Outside dia. D	A	G	B	
W3205SS-2D-C5Z10	310	32	10	6.350	33	26.4	2.5×2	46 300	108 000	3 240	83	74	108	41	15	190
W3207SS-2D-C5Z10	510															
W3210SS-5D-C5Z10	810															
W3214SS-2D-C5Z10	1 210															
W3218SS-2D-C5Z10	1 610															
W3607SS-2D-C5Z10	507															
W3612SS-2D-C5Z10	1 007	36	10	6.350	37	30.4	2.5×2	49 300	123 000	3 430	93	75	120	45	18	193
W3620SS-2D-C5Z10	1 807															

- Notes: 1. Use of NSK support unit is recommended. See page B389 for details.
 2. Only rust preventive agent is applied at time of delivery. Please apply lubricant (oil or grease) before use. See page D13 for details.
 3. The permissible rotational speed is determined by d-n value, critical speed, and maximum rotational speed. See B299 and B47. The permissible rotational speed shown in the table is the value when the ball screw mounting method is Fixed-Fixed.

Unit: mm

dimensions				Screw shaft dimensions					Lead accuracy			Run-out			Mass (kg)	Permissible rotational speed N (min ⁻¹)	Internal spatial volume of nut (cm ³)	Standard volume of grease replenishing (cm ³)				
Bolt hole		Oil hole		Threaded length	Shaft end, right		Shaft end, left		Overall length	Travel compensation	Deviation	Variation	Shaft straightness	Nut O.D. eccentricity					Flange perpendicularity			
W	X	Y	Z	Q	L _r	d ₂	L ₁	L ₂	d ₃	L ₃	L ₀	T	e _p	v _u					I	J	K	
90	9	14	8.5	M6×1	500	32.3	60	300	26.4	100	850	-0.012	0.027	0.020	0.075	0.019	0.013	9.5	2 180	57	29	
					700					100		-0.017	0.035	0.025				0.090				10.6
					1 000					100		-0.024	0.040	0.027				0.120				12.5
					1 400					120		-0.034	0.054	0.035				0.150				15.1
					1 800					120		-0.043	0.065	0.040				0.200				17.2
98	11	17.5	11	M6×1	700	36.3	60	350	30.4	100	1 100	-0.017	0.035	0.025	0.065	0.019	0.013	12.8	1 940	67	34	
					1 200					120		-0.029	0.046	0.030				0.100				16.8
					2 000					120		-0.048	0.065	0.040				0.130				22.3

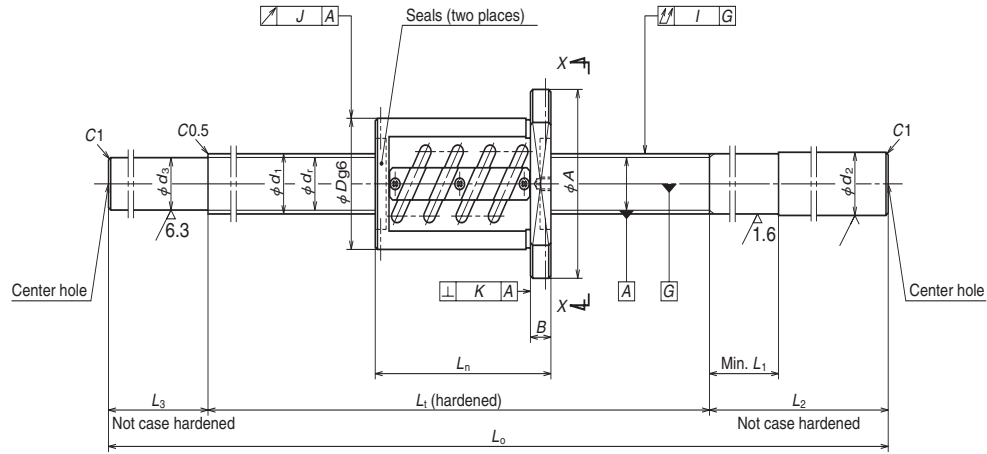

Nut type code: ZFT

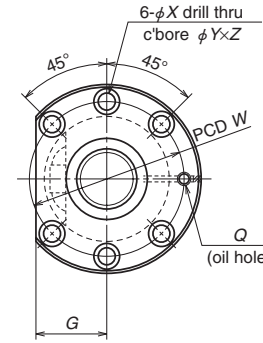

View X-X

Ball screw No.	Stroke Max. L _r -L _n	Screw shaft dia. d ₁	Lead l	Ball dia. D _w	Ball circle dia. d _m	Root dia. d _r	Effective ball turns × Circuits	Basic load rating (N)			Dynamic friction torque, median (N·cm)	Nut				
								Dynamic C _a	Static C _{0a}	Preload (N)		Flange				Overall length L _n
												Outside dia. D	A	G	B	
W4007SS-1Z-C5Z8	570	40	8	4.762	40.5	35.5	2.5×2	34 900	103 000	2 450	64	74	108	41	15	130
W4012SS-1Z-C5Z8	1 070															
W4018SS-1Z-C5Z8	1 670															
W4007SS-2Z-C5Z10	597	40	10	6.350	41	34.4	2.5×1	28 600	68 600	2 160	64	82	124	47	18	103
W4010SS-2Z-C5Z10	897															
W4014SS-1Z-C5Z10	1 297															
W4018SS-2Z-C5Z10	1 697	40	12	7.144	41.5	34.1	2.5×1	33 600	77 500	2 550	83	86	128	48	18	117
W4024SS-1Z-C5Z10	2 297															
W4010SS-4Z-C5Z12	883															
W4016SS-2Z-C5Z12	1 483	40	12	7.144	41.5	34.1	2.5×1	33 600	77 500	2 550	83	86	128	48	18	117
W4025SS-1Z-C5Z12	2 383															

- Notes: 1. Use of NSK support unit is recommended. See page B389 for details.
 2. Only rust preventive agent is applied at time of delivery. Please apply lubricant (oil or grease) before use. See page D13 for details.
 3. The permissible rotational speed is determined by d-n value, critical speed, and maximum rotational speed. See B299 and B47. The permissible rotational speed shown in the table is the value when the ball screw mounting method is Fixed-Fixed.

Unit: mm

dimensions				Screw shaft dimensions					Lead accuracy			Run-out			Mass (kg)	Permissible rotational speed N (min ⁻¹)	Internal spatial volume of nut (cm ³)	Standard volume of grease replenishing (cm ³)									
Bolt hole		Oil hole		Threaded length L _t	Shaft end, right		Shaft end, left		Overall length L _o	Travel compensation T	Deviation e _p	Variation v _u	Shaft straightness I	Nut O.D. eccentricity J					Flange perpendicularity K								
W	X	Y	Z		Q	L ₁	L ₂	d ₃												L ₃							
90	9	14	8.5	Rc1/8	700	40.3	50	300	35.5	100	1 100	-0.017	0.035	0.025	0.065	0.019	0.013	13.0	1 750	27	14						
					1 200			350		100												1 650	-0.029	0.046	0.030	0.100	18.0
					1 800			350		120												2 270	-0.043	0.065	0.040	0.130	23.5
102	11	17.5	11	Rc1/8	700	40.3	60	300	34.4	100	1 100	-0.017	0.035	0.025	0.065	0.025	0.015	13.3	1 750	30	15						
					1 000			300		100												1 400	-0.024	0.040	0.027	0.080	15.9
					1 400			350		120												1 870	-0.034	0.054	0.035	0.100	20.0
					1 800			350		120												2 270	-0.043	0.065	0.040	0.130	23.4
					2 400			400		150												2 950	-0.058	0.077	0.046	0.170	29.4
106	11	17.5	11	Rc1/8	1 000	40.3	70	300	34.1	100	1 400	-0.024	0.040	0.027	0.080	0.025	0.015	16.7	1 750	35	18						
					1 600			350		150												2 100	-0.038	0.054	0.035	0.130	22.9
					2 500			400		150												3 050	-0.060	0.077	0.046	0.170	31.1

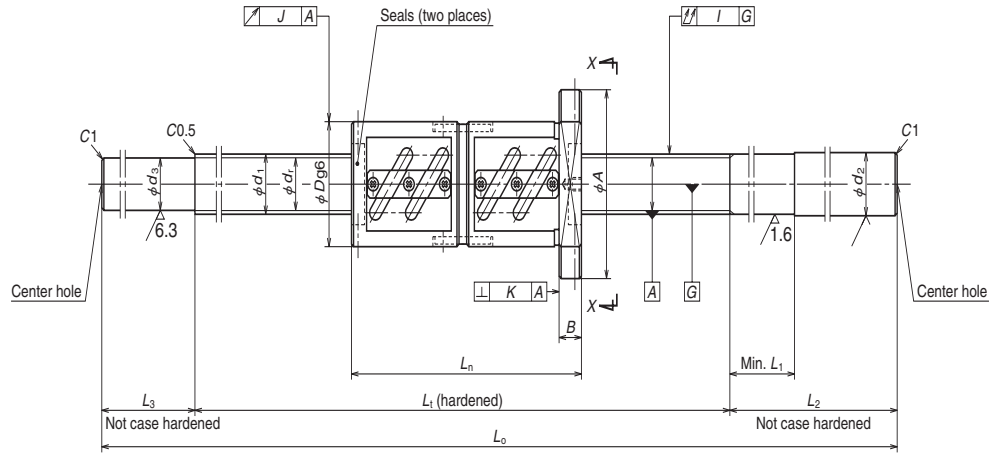

Nut type code: DFT

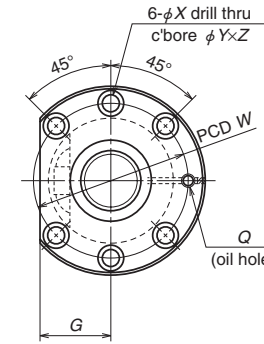

View X-X

Ball screw No.	Stroke Max. L _r -L _n	Screw shaft dia. d ₁	Lead l	Ball dia. D _w	Ball circle dia. d _m	Root dia. d _r	Effective ball turns × Circuits	Basic load rating (N)			Dynamic friction torque, median (N·cm)	Nut				
								Dynamic C _a	Static C _{0a}	Preload (N)		Outside dia. D	Flange			Overall length L _n
													A	G	B	
W4007SS-3D-C5Z10	507	40	10	6.350	41	34.4	2.5×2	52 000	137 000	3 630	108	82	124	47	18	193
W4010SS-3D-C5Z10	807															
W4014SS-2D-C5Z10	1 207															
W4018SS-3D-C5Z10	1 607															
W4024SS-2D-C5Z10	2 207															
W4010SS-5D-C5Z12	775	40	12	7.144	41.5	34.1	2.5×2	61 000	155 000	4 310	138	86	128	48	18	225
W4016SS-3D-C5Z12	1 375															
W4025SS-2D-C5Z12	2 275															

- Notes: 1. Use of NSK support unit is recommended. See page B389 for details.
 2. Only rust preventive agent is applied at time of delivery. Please apply lubricant (oil or grease) before use. See page D13 for details.
 3. The permissible rotational speed is determined by d-n value, critical speed, and maximum rotational speed. See B299 and B47. The permissible rotational speed shown in the table is the value when the ball screw mounting method is Fixed-Fixed.

Unit: mm

dimensions				Screw shaft dimensions					Lead accuracy			Run-out			Mass (kg)	Permissible rotational speed N (min ⁻¹)	Internal spatial volume of nut (cm ³)	Standard volume of grease replenishing (cm ³)		
Bolt hole		Oil hole		Threaded length L _t	Shaft end, right		Shaft end, left		Overall length L _o	Travel compensation T	Deviation e _p	Variation v _u	Shaft straightness I	Nut O.D. eccentricity J					Flange perpendicularity K	
W	X	Y	Z		Q	L ₁	L ₂	L ₃												L ₄
102	11	17.5	11	Rc1/8	700	40.3	60	300	34.4	100	1 100	-0.017	0.035	0.025	0.065	0.025	0.015	15.5	74	37
					1 000			300		100	1 400	-0.024	0.040	0.027	0.080			18.1		
					1 400			350		120	1 870	-0.034	0.054	0.035	0.100			22.2		
					1 800			350		120	2 270	-0.043	0.065	0.040	0.130			25.6		
					2 400			400		150	2 950	-0.058	0.077	0.046	0.170			31.6		
106	11	17.5	11	Rc1/8	1 000	40.3	70	300	34.1	100	1 400	-0.024	0.040	0.027	0.080	0.025	0.015	19.7	93	47
					1 600			350		150	2 100	-0.038	0.054	0.035	0.130			25.8		
					2 500			400		150	3 050	-0.060	0.077	0.046	0.170			34.0		

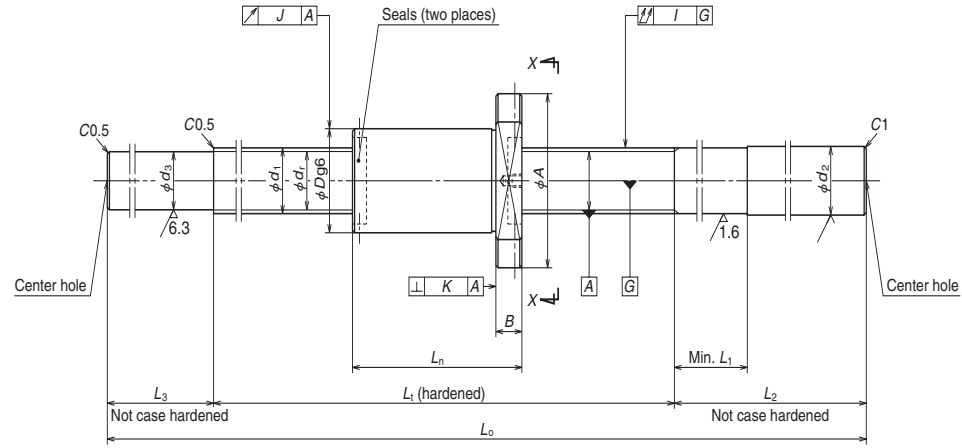

Nut type code: ZFD

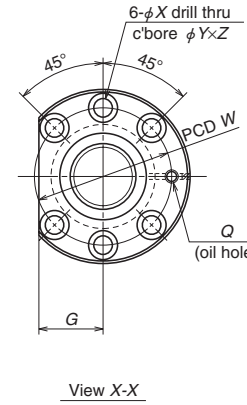

Ball screw No.	Stroke Max. L_r-L_n	Screw shaft dia. d_1	Lead l	Ball dia. D_w	Ball circle dia. d_m	Root dia. d_r	Effective ball turns	Basic load rating (N)			Dynamic friction torque, median (N·cm)	Nut								
								Dynamic C_a	Static C_{0a}	Preload (N)		Outside dia. D	Flange			Overall length L_n				
													A	G	B					
W4007SS-4ZY-C5Z10	557																			
W4010SS-6ZY-C5Z10	857																			
W4014SS-3ZY-C5Z10	1 257	40	10	6.350	41.75	35.1	4	38 400	93 300	2 840	83	62	104	40	18	143				
W4018SS-4ZY-C5Z10	1 657																			
W4024SS-3ZY-C5Z10	2 257																			
W5007SS-1ZY-C5Z10	557																			
W5010SS-3ZY-C5Z10	857																			
W5015SS-3ZY-C5Z10	1 357	50	10	6.350	51.75	45.1	4	43 600	122 000	3 240	108	72	114	44	18	143				
W5020SS-3ZY-C5Z10	1 857																			
W5026SS-3ZY-C5Z10	2 457																			

- Notes: 1. Use of NSK support unit is recommended. See page B389 for details.
 2. Only rust preventive agent is applied at time of delivery. Please apply lubricant (oil or grease) before use. See page D13 for details.
 3. The permissible rotational speed is determined by d-n value, critical speed, and maximum rotational speed. See B299 and B47. The permissible rotational speed shown in the table is the value when the ball screw mounting method is Fixed-Fixed.

Unit: mm

dimensions				Screw shaft dimensions					Lead accuracy			Run-out			Mass (kg)	Permissible rotational speed (min ⁻¹)	Internal spatial volume of nut (cm ³)	Standard volume of grease replenishing (cm ³)		
Bolt hole				Threaded length L_t	Shaft end, right		Shaft end, left		Overall length L_o	Travel compensation T	Deviation e_p	Variation v_u	Shaft straightness I	Nut O.D. eccentricity J					Flange perpendicularity K	
W	X	Y	Z		Oil hole Q	d_2	L_1	L_2												d_3
82	11	17.5	11	Rc1/8	700	40.3	60	300	100	1 100	-0.015	0.035	0.025	0.065	0.019	0.013	12.1	1 750	32	16
					1 000			300	100	1 400	-0.022	0.040	0.027	0.080			14.7			
					1 800			350	120	2 270	-0.032	0.054	0.035	0.100			22.5			
					2 400			400	150	2 950	-0.056	0.077	0.046	0.170			28.5			
92	11	17.5	11	Rc1/8	700	50.3	60	300	100	1 100	-0.015	0.035	0.025	0.065	0.019	0.013	18.3	1 400	39	20
					1 000			300	100	1 400	-0.022	0.040	0.027	0.080			22.5			
					1 500			400	150	2 050	-0.034	0.054	0.035	0.130			31.8			
					2 000			400	150	2 550	-0.046	0.065	0.040	0.170			38.9			
					2 600		500	200	3 300	-0.060	0.093	0.054	0.220			49.5				

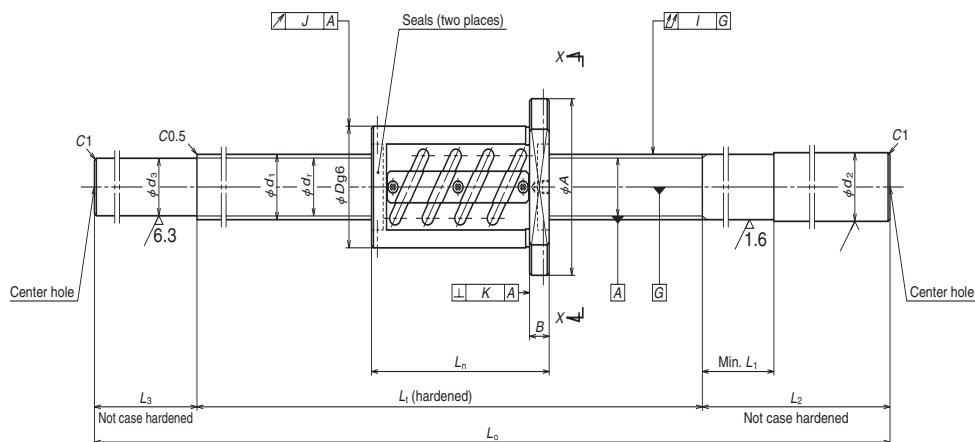

Nut type code: ZFT

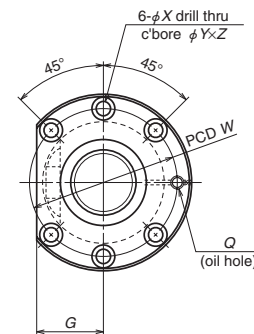

View X-X

Unit: mm

Ball screw No.	Stroke Max. $L-L_n$	Screw shaft dia. d_1	Lead l	Ball dia. D_w	Ball circle dia. d_m	Root dia. d_r	Effective ball turns \times Circuits	Basic load rating (N)			Dynamic friction torque, median (N-cm)	Nut				
								Dynamic C_a	Static C_{0a}	Preload (N)		Flange				Overall length L_n
												Outside dia. D	A	G	B	
W4510SS-1Z-C5Z10	897	45	10	6.350	46	39.4	2.5×1	29 900	77 300	2 260	69	88	132	50	18	103
W4516SS-1Z-C5Z10	1 497															
W4525SS-1Z-C5Z10	2 397															
W5010SS-1Z-C5Z10	897	50	10	6.350	51	44.4	2.5×1	31 800	87 400	2 450	78	93	135	51	18	103
W5015SS-1Z-C5Z10	1 397															
W5020SS-1Z-C5Z10	1 897															
W5026SS-1Z-C5Z10	2 497	50	10	6.350	51	44.4	2.5×2	57 700	175 000	4 020	138	93	135	51	18	163
W5010SS-2Z-C5Z10	837															
W5015SS-2Z-C5Z10	1 337															
W5020SS-2Z-C5Z10	1 837	50	10	6.350	51	44.4	2.5×2	57 700	175 000	4 020	138	93	135	51	18	163
W5026SS-2Z-C5Z10	2 437															

- Notes: 1. Use of NSK support unit is recommended. See page B389 for details.
 2. Only rust preventive agent is applied at time of delivery. Please apply lubricant (oil or grease) before use. See page D13 for details.
 3. The permissible rotational speed is determined by d-n value, critical speed, and maximum rotational speed. See B299 and B47. The permissible rotational speed shown in the table is the value when the ball screw mounting method is Fixed-Fixed.

dimensions				Screw shaft dimensions					Lead accuracy			Run-out			Mass (kg)	Permissible rotational speed (min ⁻¹)	Internal spatial volume of nut (cm ³)	Standard volume of grease replenishing (cm ³)			
Bolt hole		Oil hole		Threaded length	Shaft end, right		Shaft end, left		Overall length	Travel compensation	Deviation	Variation	Shaft straightness	Nut O.D. eccentricity					Flange perpendicularity		
W	X	Y	Z	Q	L_1	d_2	L_1	L_2	d_3	L_3	L_o	T	e_p	v_u					I	J	K
110	11	17.5	11	Rc1/8	1 000	45.3	60	300	39.4	100	1 400	-0.024	0.040	0.027	0.080	0.025	0.015	19.7	1 550	34	17
					1 600			400		150	2 150	-0.038	0.054	0.035	0.130			28.1			
					2 500			450		150	3 100	-0.060	0.077	0.046	0.170			38.8			
113	11	17.5	11	Rc1/8	1 000	50.3	60	300	44.4	100	1 400	-0.024	0.040	0.027	0.080	0.025	0.015	23.8	1 400	37	19
					1 500			400		150	2 050	-0.036	0.054	0.035	0.130			32.9			
					2 000			400		150	2 550	-0.048	0.065	0.040	0.170			39.8			
					2 600			450		150	3 200	-0.062	0.093	0.054	0.220			48.9			
113	11	17.5	11	Rc1/8	1 000	50.3	60	300	44.4	100	1 400	-0.024	0.040	0.027	0.080	0.025	0.015	25.5	1 400	59	30
					1 500			400		150	2 050	-0.036	0.054	0.035	0.130			34.6			
					2 000			400		150	2 550	-0.048	0.065	0.040	0.170			41.5			
					2 600			450		150	3 200	-0.062	0.093	0.054	0.220			50.7			

B-3-1.6 Ball Screws for Transfer Equipment

1. Features

● Transporting mechanism

A series with accuracy grades of Ct7 and Ct10 only demonstrates high ball screw performance for transporting mechanism of Cartesian type robots and single axis actuators.

The following types are categorized ball screw for transfer equipment. VFA and RMA types have finished shaft ends. RMS type, R series of RNFTL, RNFBL, RNCT, RNFL, and RNSTL types have blank shaft ends.

Table 1 Classifications of ball screws for transfer equipment

Finished shaft end	VFA type, RMA type
	RMS type
Blank shaft end	R Series
	RNFTL type, RNFBL type
	RNCT type, RNFL type, RNSTL type

● Interchangeable screw shaft and ball nut

Screw shaft and nut assembly components are sold separately, and randomly-matched. The maximum axial play after assembly is shown in the dimension tables.

2. Specifications

(1) Ball recirculation system

Figs. 1, 2, and 3 show the structures of ball return tube, deflector (bridge type), and end cap ball recirculation systems.

Deflector (bridge type) recirculation system has the feature of compact nut outside diameter for small lead. End cap recirculation system is for screws with high helix lead and multiple start threads. Since the leads are in the range larger than 1.3 times of the screw shaft diameter, it is suitable for high-speed operation.

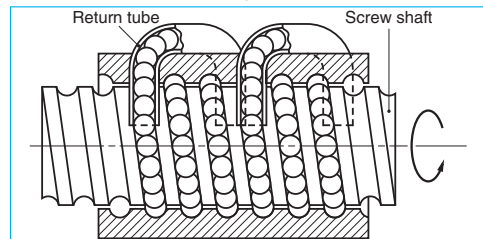

Fig. 1 Structure of return tube recirculation system

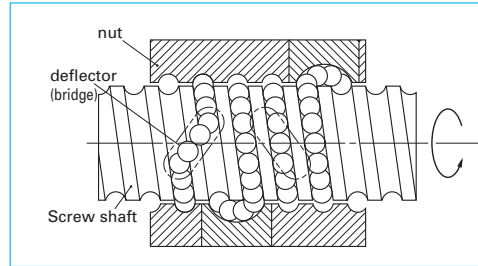

Fig. 2 Structure of deflector (bridge type) recirculation system

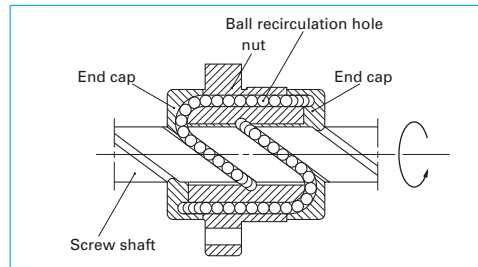

Fig. 3 Structure of end cap recirculation system

(2) Accuracy grade and axial play

Standard lead accuracy and axial play are shown on **Table 2**. Axial play varies with internal specification. Refer to the dimension tables.

Table 2 Accuracy grade and axial play

Accuracy grade	VFA type, RMA type, RMS type: Ct7 R Series: Ct10
Axial play	See dimension tables

(3) Allowable d·n value and the criterion of maximum rotational speed

Allowable d·n value and the criterion of maximum rotational speed are shown below. Please consult NSK if the rotational speed exceeds the permissible range below.

Table 3 Allowable d·n value and the criterion of maximum rotational speed

Allowable d·n value	50 000 or less
Criterion of maximum rotational speed	3 000 min ⁻¹

d·n value: shaft dia. d [mm] × rotational speed n [min⁻¹]

Note: Please also review the critical speed. See "Technical Description: Permissible Rotational Speed" (page B47) for details.

3. Product categories

Ball screws for transfer equipment have models as follows.

Table 4 Product categories of ball screws for transfer equipment

Nut model	Shape	Flange shape	Recirculation system	Preload system	Page
VFA		Flanged rectangular	Return tube type	Non-preload Slight axial play	353 - B358
RMA RMS		Flanged Circular III	Deflector (bridge) type	Non-preload Slight axial play	B359 - B372
RNFTL		Flanged Circular I Projecting tube type	Return tube type	Non-preload Slight axial play	B373 - B378
RNFBL		Flanged Circular II	Return tube type	Non-preload Slight axial play	B379 - B380
RNCT		V-thread (no flange) Projecting tube type	Return tube type	Non-preload Slight axial play	B381 - B382
RNFL		Flanged Circular III	End cap type	Non-preload Slight axial play	B383 - B386
RNSTL		Square type	Return tube type	Non-preload Slight axial play	B387 - B388

4. Structure of reference number

The followings describe the structure of "Reference number for ball screw".

◇Reference number for VFA, RMA, and RMS types

VFA 15 10 - C7 S - 500

Ball screw for transfer equipment:
VFA, RMA, RMS

Screw shaft diameter (mm)

Lead (mm)

Screw shaft length (mm)

Axial play

Accuracy grade code

◇Reference number for R series

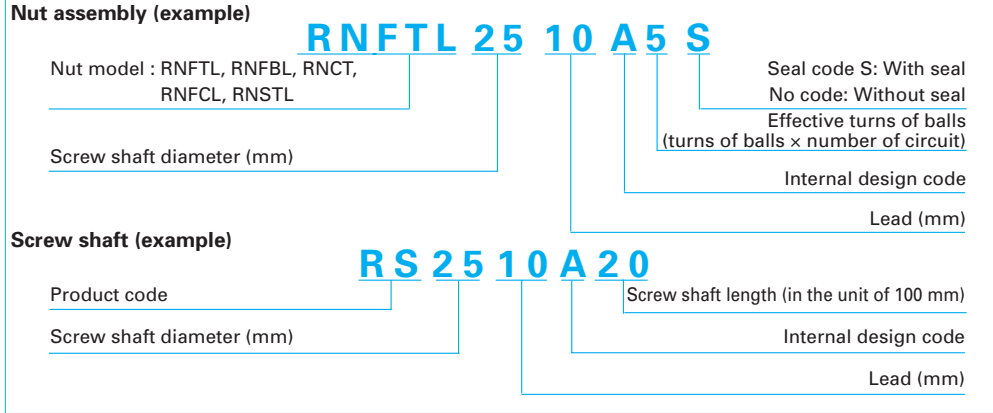

5. Combinations of shaft diameter and lead

Combinations of shaft diameter and lead are shown below.
For details of standard stock products, contact NSK.

Table 5 Combinations of shaft diameter and lead for VFA, RMA, RMS types

Screw shaft diameter	Lead				
	1	1.5	2	10	20
6	B359, 371				
8	B361, 371	B363, 371	B365, 371		
10			B367, 371		
12			B369, 371	B353	
15				B355	B357

Table 6 Combinations of shaft diameter and lead for R series

Screw shaft diameter (mm)	Lead (mm)															
	3	4	5	6	8	10	12	16	20	25	32	40	50	64	80	
10	○B373 △B381			○B373 ●B379												
12					○B373 ●B379		○B377 ○B383									
14		○B373 ●B379 △B381 □B387	○B373 ●B379 △B381 □B387													
15									○B383							
16						○B373		○B377 ○B383		○B385						
18				○B373 ●B379 △B381 □B387												
20			○B373 ●B379 △B381 □B387			○B373 ●B379 △B381 □B387		○B377 ○B383		○B385						
25			○B373 ●B379 △B381 □B387			○B369 ●B365 △B367 □B373		○B377 ○B383		○B385						
28				○B375 ●B379 △B381 □B387												
32						○B375 ●B379 △B381 □B387					○B377 ○B383		○B385			
36						○B375 ●B379 △B381 □B387										
40						○B375 △B381 ●B379					○B377 ○B383		○B385			
45							○B375 △B381 □B387									
50							○B375 △B381		○B375 △B381				○B383			

○: RNFTL ●: RNFB △: RNCT ◎: RNFL □: RNSTL

6. Precautions for designing

As shown in the illustration on Page B83 and B103, general precautions for ball screw.

(1) Nut assembly

When delivered, the nut of R series is separated from the screw shaft, and inserted into an arbor shaft. The nut must be inserted to the screw shaft when mounting ball screw.

(a) Consideration to end configuration of screw shaft

The balls may fall out during moving the assembled nut from the arbor to the screw shaft if the sizes and shapes of the arbor and the screw shaft are not appropriate.

If the end of the ball groove can touch the end of the arbor, connect both ends and move the assembled nut from the arbor to the screw shaft (Fig. 4).

If the end face of the arbor cannot connect to the end face of the screw because of configuration of both ends of screw shaft, wrap a tape outside of ball screw shaft so that the layers of tape is equal

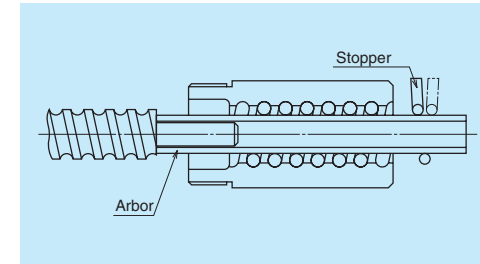

Fig. 4 Inserting nut into screwshaft

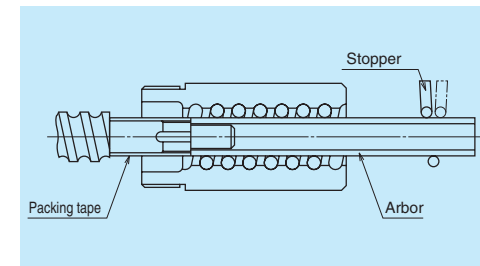

Fig. 5 Arbor and shaft end configuration

with the outside diameter of the arbor (Fig. 5). If there is a key way or a nick along the way, fill such gaps prior to moving the ball nut.

(b) Installation of arbor

Confirm the correct nut orientation for installation.

Remove the stop ring on the side from where the assembled nut is to be removed. Align the centers of the screw shaft and the arbor while pressing firmly the screw shaft end against the arbor.

(c) Moving the nut

Slide the nut until it lightly touches the shoulder of the ball groove section, and stop it. Turn the ball nut to the direction so that it moves to the ball grooves, while pressing the arbor to the screw shaft. Do not separate the arbor from the screw shaft until the ball groove end appears completely in the ball nut.

(2) Shaft end configuration

RMS type and R series must be machining of blank shaft ends. See page B27, use of NSK suport unit.

(a) Cutting screw shaft

Carry out the same process as "(1) Machining of blank shaft ends of precision ball screws" above.

(b) Annealing the shaft end (Heat the section of the shaft end to be machined with an acetylene torch. Then gradually cool it in ambient atmosphere.)

* The area not machined loses hardness if exposed to heat. This may shorten the all screw life. Cool with water the areas where should not be heated to avoid heat conduction.

(c) Turning by lathe

Cut to the length, turn shaft end steps, turn thread screw, and provide the center hole. Refer to JIS B1192 which sets standards for the shaft end accuracy.

(d) Processing by grinding

Apply the same precautions as for cutting for centering, securing nut, and work rest. Grind sections where the bearings and a "Span ring" are installed.

(e) Milling processing

Process keyways and tooth seats for lock washers.

(f) Deburring, washing, and rust prevention
Wash with clean white kerosene after processing. Apply lubricant for immediate use. For later use, apply rust preventive agent.

Note: Contact NSK if nut is accidentally removed.

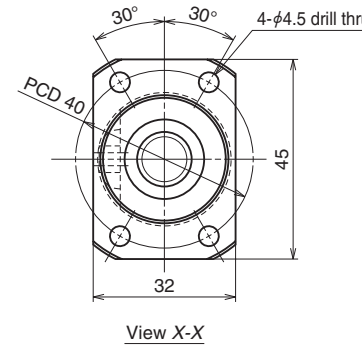
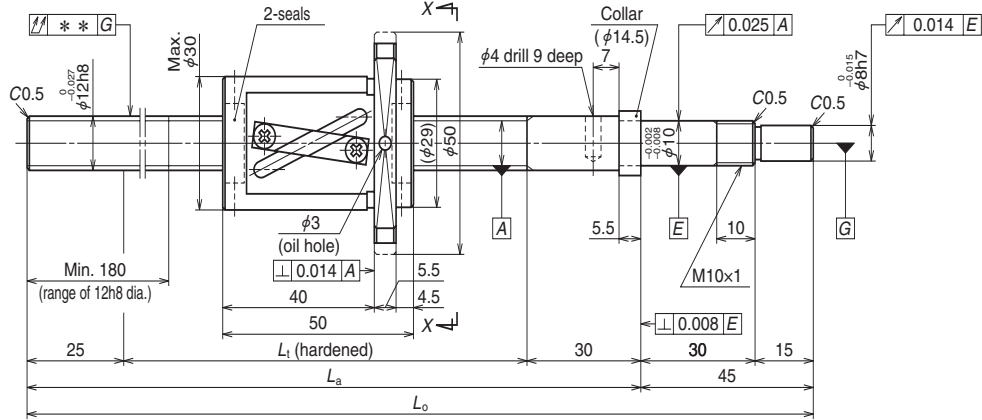

Ball screw specification		
Shaft dia. x Lead / Direction of turn	12 × 10 / Right	
Ball recirculation	Return tube	
Ball dia. / Ball circle dia.	2.381 / 12.5	
Screw shaft root dia.	10.0	
Effective turns of balls	2.5 × 1	
Accuracy grade / Axial play code	Ct7 / S	
Basic load rating (N)	Dynamic C _a	3 750
	Static C _{0a}	6 480
Axial play	0.010 or less	
Dynamic friction torque (N·cm)	1.5 or less	
Spacer ball	None	
Factory-packed grease	NSK grease LR3	
Internal spatial volume of nut (cm ³)	1.4	
Reference of grease replenishing amount	0.7	

Recommended support unit

For drive side (Fixed)	For opposite to drive side (Simple)
WBK10-01A (square)	WBK12SF-01 (square)
WBK10-11 (round)	

Ball screw No.	Stroke		Screw shaft length		
	Nominal	Maximum (L _r -nut length)	L _t	L _a	L _o
VFA1210C7S-410	250	260	310	365	410
VFA1210C7S-610	450	460	510	565	610

Lead accuracy			Shaft run-out**	Mass (kg)	Permissible rotational speed N (min ⁻¹)	
T	e _p	v ₃₀₀			Supporting condition	
					Fixed - Simple support	Fixed - Free
0	0.085	0.052	0.100	0.56	3 000	3 000
0	0.155	0.052	0.160	0.73	3 000	1 300

- Notes: 1. We recommend NSK support units (page B389). WBK12SF-01 (on simple support side) supports ball screw directly on shaft outside diameter.
 2. Use of NSK grease LR3 is recommended. Recommended quantity of grease is about 50% of ball nut's internal space. See page D16 for details.
 3. Permissible rotational speed is determined by d · n value and critical speed. See pages B47 and B349.

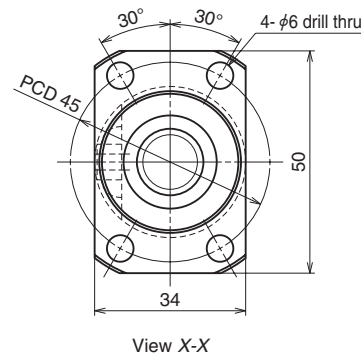
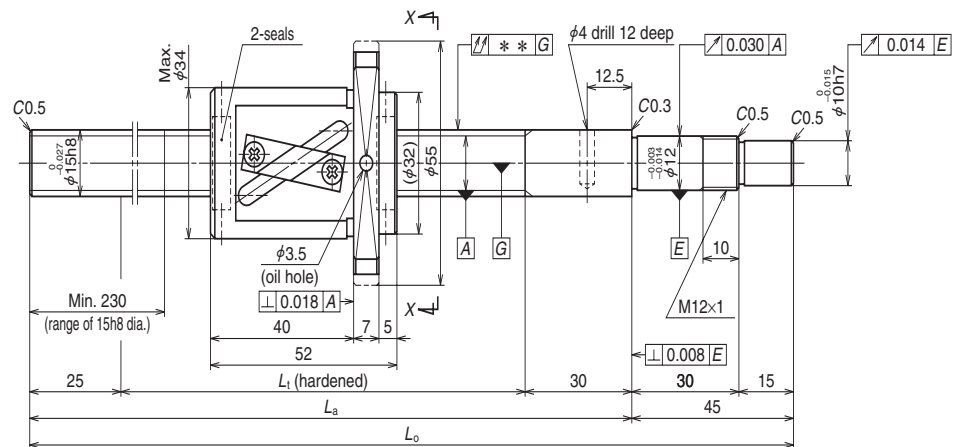

Ball screw specification

Shaft dia.xLead / Direction of turn	15 × 10 / Right	
Ball recirculation	Return tube	
Ball dia. / Ball circle dia.	3.175 / 15.5	
Screw shaft root dia.	12.2	
Effective turns of balls	2.5 × 1	
Accuracy grade / Axial play code	Ct7 / S	
Basic load rating (N)	Dynamic C_a	7 070
	Static C_{0a}	12 800
Axial play	0.010 or less	
Dynamic friction torque (N-cm)	2.5 or less	
Spacer ball	None	
Factory-packed grease	NSK grease LR3	
Internal spatial volume of nut (cm ³)	2.3	
Reference of grease replenishing amount	1.2	

Recommended support unit

For drive side (Fixed)	For opposite to drive side (Simple)
WBK12-01A (square)	WBK15SF-01 (square)
WBK12-11 (round)	

Ball screw No.	Stroke		Screw shaft length		
	Nominal	Maximum (L_r -nut length)	L_t	L_a	L_o
VFA1510C7S-500	300	348	400	455	500
VFA1510C7S-700	500	548	600	655	700
VFA1510C7S-1000	800	848	900	955	1 000

- Notes: 1. We recommend NSK support units (page B389). WBK12SF-01 (on simple support side) supports ball screw directly on shaft outside diameter.
 2. Use of NSK grease LR3 is recommended. Recommended quantity of grease is about 50% of ball nut's internal space. See page D16 for details.
 3. Permissible rotational speed is determined by $d \cdot n$ value and critical speed. See pages B47 and B349.

Unit: mm

Lead accuracy			Shaft run-out**	Mass (kg)	Permissible rotational speed N (min ⁻¹)	
T	e_p	v_{300}			Supporting condition	
					Fixed - Simple support	Fixed - Free
0	0.120	0.052	0.075	0.89	3 000	2 600
0	0.195	0.052	0.110	1.1	3 000	1 150
0	0.310	0.052	0.180	1.5	2 340	510

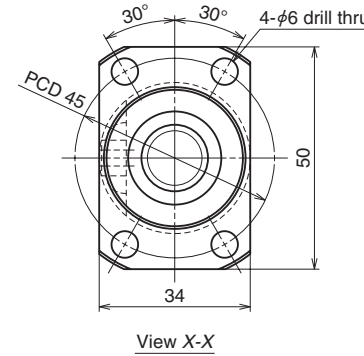
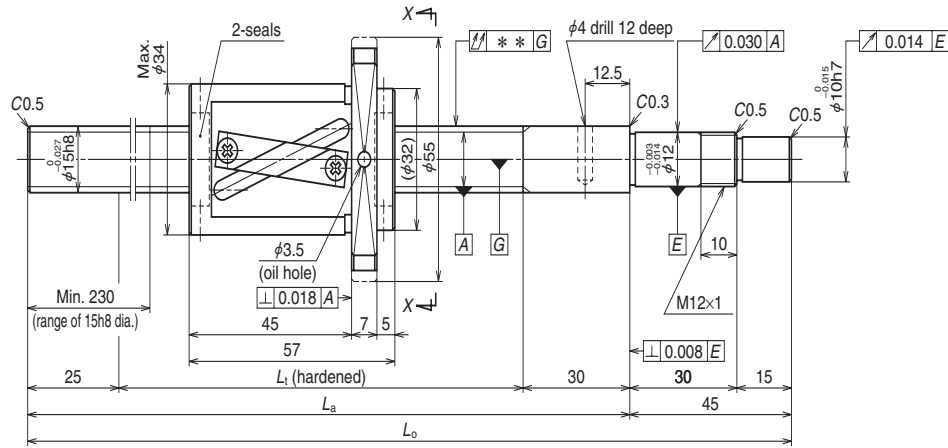

Ball screw specification

Shaft dia. x Lead / Direction of turn	15 × 20 / Right	
Ball recirculation	Return tube	
Ball dia. / Ball circle dia.	3.175 / 15.5	
Screw shaft root dia.	12.2	
Effective turns of balls	1.5 × 1	
Accuracy grade / Axial play code	Ct7 / S	
Basic load rating (N)	Dynamic C_a	4 560
	Static C_{0a}	7 730
Axial play	0.010 or less	
Dynamic friction torque (N·cm)	2.5 or less	
Spacer ball	None	
Factory-packed grease	NSK grease LR3	
Internal spatial volume of nut (cm ³)	2.3	
Reference of grease replenishing amount	1.4	

Recommended support unit

For drive side (Fixed)	For opposite to drive side (Simple)
WBK12-01A (square)	WBK15SF-01 (square)
WBK12-11 (round)	

VFA

Ball screw No.	Stroke		Screw shaft length		
	Nominal	Maximum (L_r -nut length)	L_t	L_a	L_o
VFA1520C7S-500	300	343	400	455	500
VFA1520C7S-700	500	543	600	655	700
VFA1520C7S-1000	800	843	900	955	1 000

- Notes: 1. We recommend NSK support units (page B389). WBK12SF-01 (on simple support side) supports ball screw directly on shaft outside diameter.
 2. Use of NSK grease LR3 is recommended. Recommended quantity of grease is about 50% of ball nut's internal space. See page D16 for details.
 3. Permissible rotational speed is determined by $d \cdot n$ value and critical speed. See pages B47 and B349.

Unit: mm

Lead accuracy			Shaft run-out**	Mass (kg)	Permissible rotational speed N (min ⁻¹)	
T	e_p	v_{300}			Supporting condition	
					Fixed - Simple support	Fixed - Free
0	0.120	0.052	0.075	0.94	3 000	2 630
0	0.195	0.052	0.110	1.2	3 000	1 160
0	0.310	0.052	0.180	1.6	2 350	510

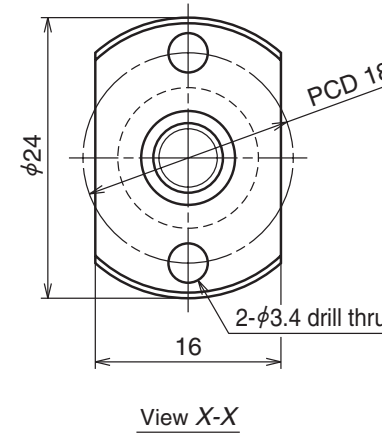
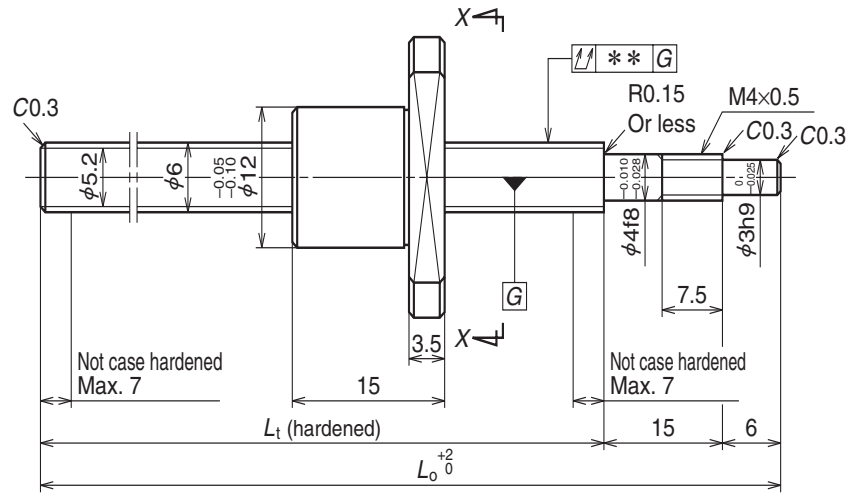

Ball screw specification		
Shaft dia.xLead / Direction of turn	6 × 1 / Right	
Ball recirculation	Deflector (bridge)	
Ball dia. / Ball circle dia.	0.800 / 6.2	
Screw shaft root dia.	5.2	
Effective turns of balls	1 × 3	
Accuracy grade / Axial play code	Ct7 / S	
Basic load rating (N)	Dynamic C_a	520
	Static C_{0a}	925
Axial play	0.020 or less	
Dynamic friction torque (N-cm)	1.0 or less	
Spacer ball	None	
Factory-packed grease	See Notes 2.	

Recommended support unit

For drive side (Fixed)	
WBK04R-11 (round)	

Ball screw No.	Stroke		Screw shaft length	
	Nominal	Maximum (L_t -Nut length)	L_t	L_o
RMA0601C7S-160	100	124	139	160
RMA0601C7S-260	200	224	239	260

Lead accuracy			Shaft run-out**	Mass (kg)	Permissible rotational speed N (min ⁻¹)
Target compensation T	Deviation e_p	Variation v_{300}			
0	0.052	0.052	0.060	0.045	3 000
0	0.085	0.052	0.090	0.065	3 000

- Notes: 1. We recommend NSK support bearing kit (page B401).
 2. Only rust preventive oil is applied at time of delivery. Please apply lubricant (oil or grease) before use. See page D13 for details.
 3. Permissible rotational speed is determined by d-n value and critical speed. See pages B47 and B349.

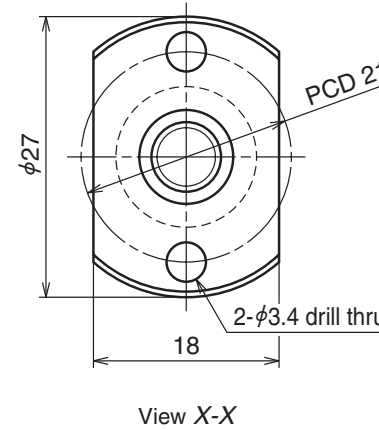
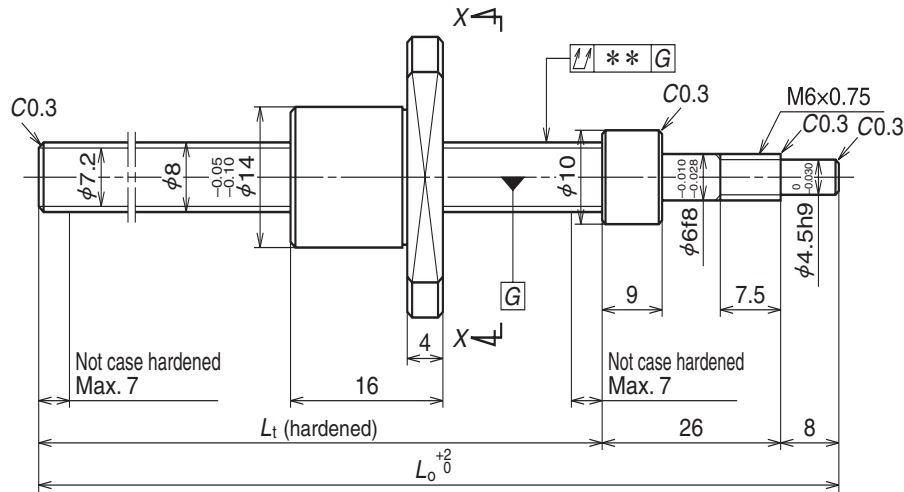

Ball screw specification		
Shaft dia. x Lead / Direction of turn	8 × 1 / Right	
Ball recirculation	Deflector (bridge)	
Ball dia. / Ball circle dia.	0.800 / 8.2	
Screw shaft root dia.	7.2	
Effective turns of balls	1 × 3	
Accuracy grade / Axial play code	Ct7 / S	
Basic load rating (N)	Dynamic C _a	600
	Static C _{0a}	1 290
Axial play	0.020 or less	
Dynamic friction torque (N-cm)	1.0 or less	
Spacer ball	None	
Factory-packed grease	See Notes 2.	

Recommended support unit

For drive side (Fixed)	
WBK06R-11 (round)	

Ball screw No.	Stroke		Screw shaft length	
	Nominal	Maximum (L _t -Nut length)	L _t	L _o
RMA0801C7S-180	100	130	146	180
RMA0801C7S-280	200	230	246	280

Unit: mm

Lead accuracy			Shaft run-out**	Mass (kg)	Permissible rotational speed N (min ⁻¹)
Target compensation T	Deviation e _p	Variation v ₃₀₀			
0	0.052	0.052	0.060	0.085	3 000
0	0.085	0.052	0.090	0.12	3 000

- Notes: 1. We recommend NSK support bearing kit (page B401).
 2. Only rust preventive oil is applied at time of delivery. Please apply lubricant (oil or grease) before use. See page D13 for details.
 3. Permissible rotational speed is determined by d-n value and critical speed. See pages B47 and B349.

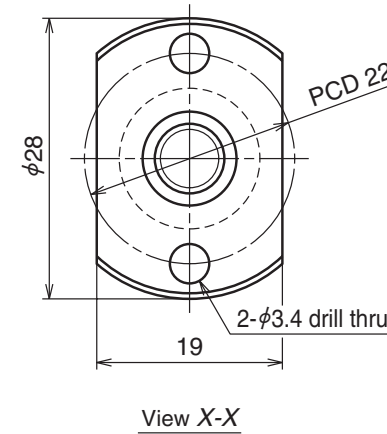
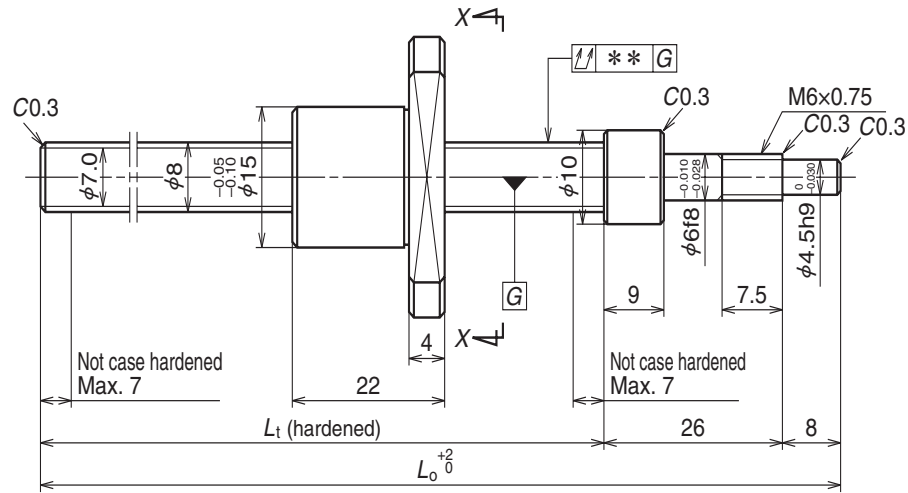

Ball screw specification		
Shaft dia.xLead / Direction of turn	8 x 1.5 / Right	
Ball recirculation	Deflector (bridge)	
Ball dia. / Ball circle dia.	1.000 / 8.3	
Screw shaft root dia.	7.0	
Effective turns of balls	1 x 3	
Accuracy grade / Axial play code	Ct7 / S	
Basic load rating (N)	Dynamic C_a	810
	Static C_{0a}	1 590
Axial play	0.020 or less	
Dynamic friction torque (N-cm)	1.0 or less	
Spacer ball	None	
Factory-packed grease	See Notes 2.	

Recommended support unit

For drive side (Fixed)	
WBK06R-11 (round)	

Ball screw No.	Stroke		Screw shaft length	
	Nominal	Maximum (L_t -Nut length)	L_t	L_o
RMA0801.5C7S-180	100	124	146	180
RMA0801.5C7S-280	200	224	246	280

Unit: mm

Lead accuracy			Shaft run-out**	Mass (kg)	Permissible rotational speed N (min^{-1})
Target compensation T	Deviation e_p	Variation v_{300}			
0	0.052	0.052	0.060	0.093	3 000
0	0.085	0.052	0.090	0.13	3 000

- Notes: 1. We recommend NSK support bearing kit (page B401).
 2. **Only rust preventive oil is applied at time of delivery. Please apply lubricant (oil or grease) before use.** See page D13 for details.
 3. Permissible rotational speed is determined by d-n value and critical speed. See pages B47 and B349.

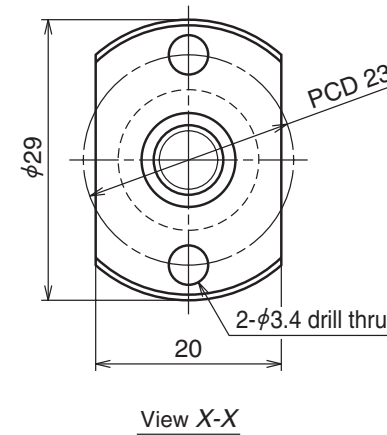
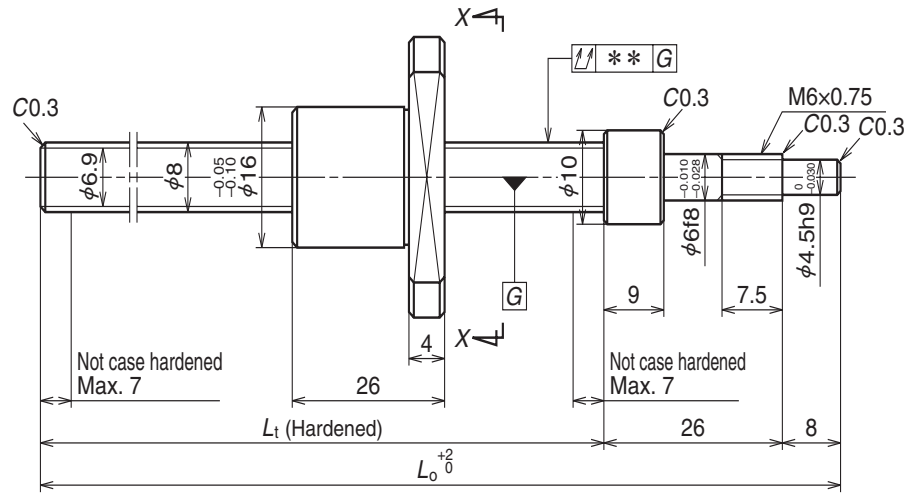

Ball screw specification		
Shaft dia.xLead / Direction of turn	8 × 2 / Right	
Ball recirculation	Deflector (bridge)	
Ball dia. / Ball circle dia.	1.200 / 8.3	
Screw shaft root dia.	6.9	
Effective turns of balls	1 × 3	
Accuracy grade / Axial play code	Ct7 / S	
Basic load rating (N)	Dynamic C_a	1 070
	Static C_{0a}	1 950
Axial play	0.020 or less	
Dynamic friction torque (N-cm)	1.0 or less	
Spacer ball	None	
Factory-packed grease	See Notes 2.	

Recommended support unit

For drive side (Fixed)	
WBK06R-11 (round)	

Ball screw No.	Stroke		Screw shaft length	
	Nominal	Maximum (L_t -Nut length)	L_t	L_o
RMA0802C7S-180	100	120	146	180
RMA0802C7S-280	200	220	246	280

Lead accuracy			Shaft run-out**	Mass (kg)	Permissible rotational speed N (min ⁻¹)
Target compensation T	Deviation e_p	Variation v_{300}			
0	0.052	0.052	0.060	0.10	3 000
0	0.085	0.052	0.090	0.14	3 000

- Notes: 1. We recommend NSK support bearing kit (page B401).
 2. **Only rust preventive oil is applied at time of delivery. Please apply lubricant (oil or grease) before use.** See page D13 for details.
 3. Permissible rotational speed is determined by d-n value and critical speed. See pages B47 and B349.

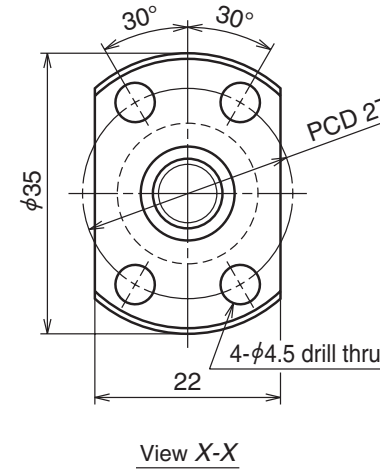
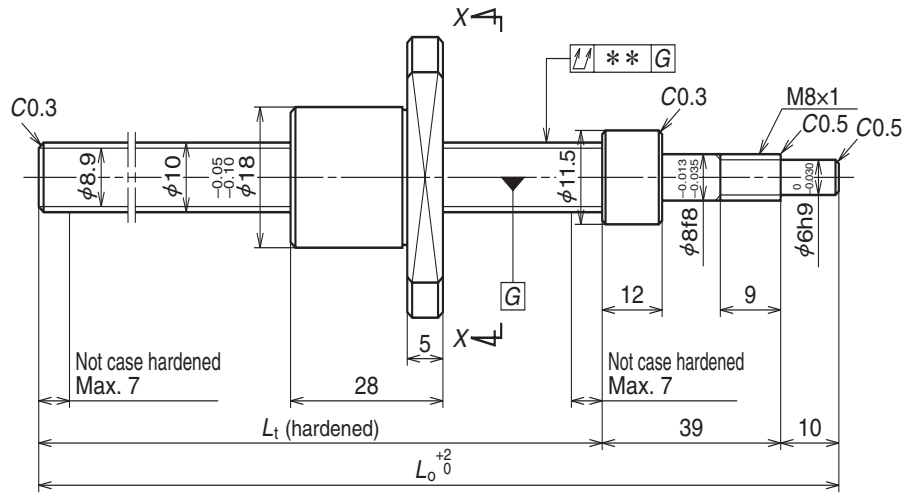

Ball screw specification		
Shaft dia. x Lead / Direction of turn	10 x 2 / Right	
Ball recirculation	Deflector (bridge)	
Ball dia. / Ball circle dia.	1.200 / 10.3	
Screw shaft root dia.	8.9	
Effective turns of balls	1 x 3	
Accuracy grade / Axial play code	Ct7 / S	
Basic load rating (N)	Dynamic C_a	1 210
	Static C_{0a}	2 510
Axial play	0.020 or less	
Dynamic friction torque (N-cm)	1.0 or less	
Spacer ball	None	
Factory-packed grease	See Notes 2.	

Recommended support unit

For drive side (Fixed)	
WBK08-01A (square)	
WBK08-11 (round)	

Ball screw No.	Stroke		Screw shaft length	
	Nominal	Maximum (L_t -Nut length)	L_t	L_o
RMA1002C7S-250	150	173	201	250
RMA1002C7S-350	250	273	301	350

Lead accuracy			Shaft run-out**	Mass (kg)	Permissible rotational speed N (min ⁻¹)
Target compensation T	Deviation e_p	Variation v_{300}			
0	0.085	0.052	0.070	0.19	3 000
0	0.085	0.052	0.100	0.25	3 000

- Notes: 1. We recommend NSK support bearing kit (page B389).
 2. Only rust preventive oil is applied at time of delivery. Please apply lubricant (oil or grease) before use. See page D13 for details.
 3. Permissible rotational speed is determined by d-n value and critical speed. See pages B47 and B349.

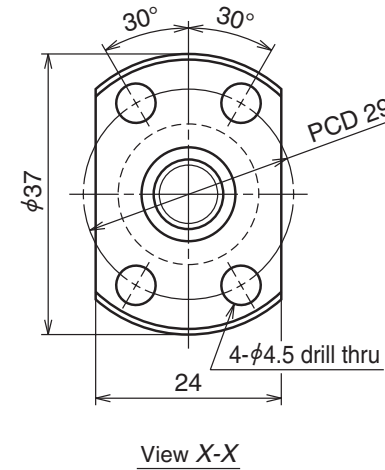
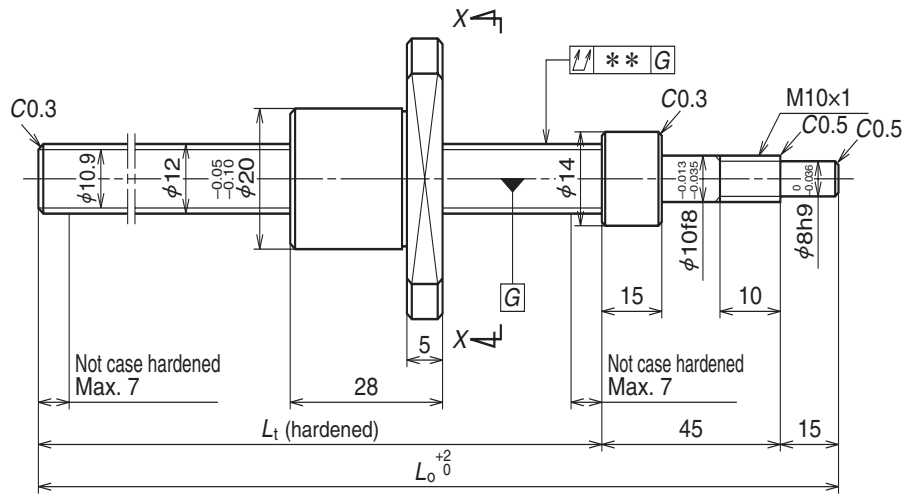

Ball screw specification		
Shaft dia.xLead / Direction of turn	12 x 2 / Right	
Ball recirculation	Deflector (bridge)	
Ball dia. / Ball circle dia.	1.200 / 12.3	
Screw shaft root dia.	10.9	
Effective turns of balls	1 x 3	
Accuracy grade / Axial play code	Ct7 / S	
Basic load rating (N)	Dynamic C_a	1 350
	Static C_{0a}	3 190
Axial play	0.020 or less	
Dynamic friction torque (N-cm)	1.0 or less	
Spacer ball	None	
Factory-packed grease	See Notes 2.	

Recommended support unit

For drive side (Fixed)	
WBK10-01A (square)	
WBK10-11 (round)	

Ball screw No.	Stroke		Screw shaft length	
	Nominal	Maximum (L_t -Nut length)	L_t	L_0
RMA1202C7S-250	150	162	190	250
RMA1202C7S-350	250	262	290	350

Unit: mm

Lead accuracy			Shaft run-out**	Mass (kg)	Permissible rotational speed N (min^{-1})
Target compensation T	Deviation e_p	Variation v_{300}			
0	0.060	0.052	0.070	0.26	3 000
0	0.085	0.052	0.100	0.34	3 000

- Notes: 1. We recommend NSK support bearing kit (page B389).
 2. Only rust preventive oil is applied at time of delivery. Please apply lubricant (oil or grease) before use. See page D13 for details.
 3. Permissible rotational speed is determined by d-n value and critical speed. See pages B47 and B349.

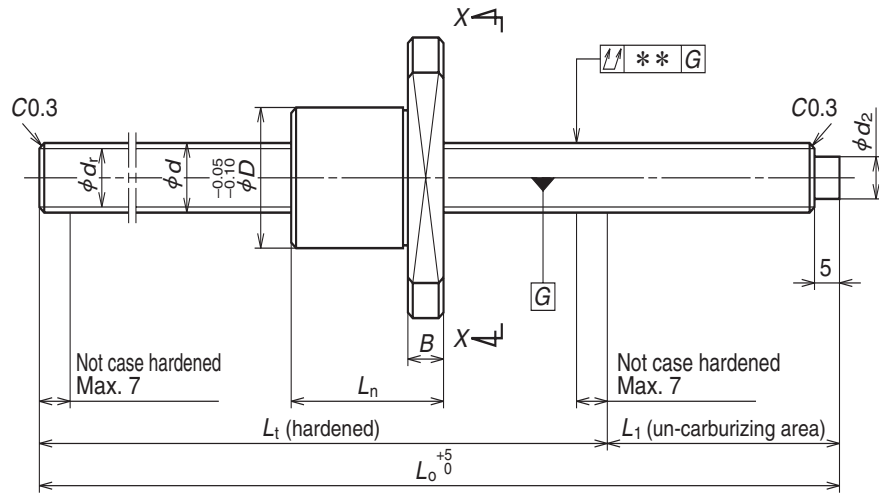

Screw shaft ø6

Lead 1

Screw shaft ø8

Lead 1, 1.5, 2

Screw shaft ø10, ø12

Lead 2

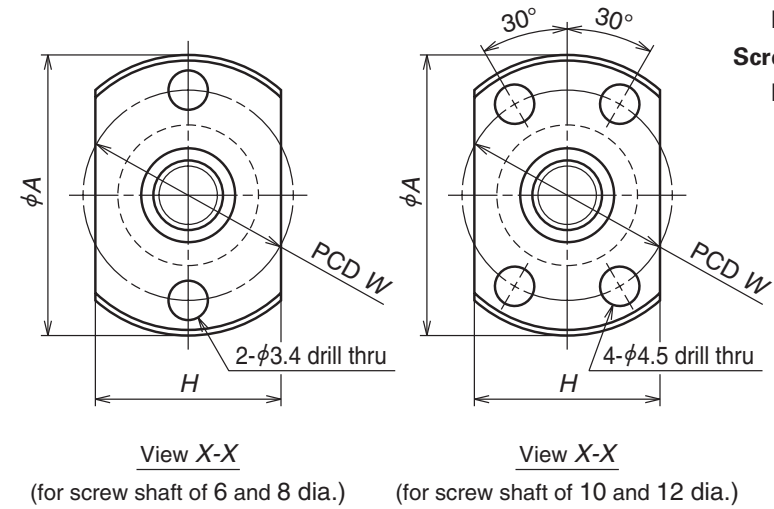

Ball screw No.	Stroke Max. L_t-L_n	Shaft dia. d	Lead l	Ball dia. D_w	Ball circle dia. d_m	Root dia. d_r	Effective turns of balls	Basic load rating (N)		Axial play Max.
								Dynamic C_d	Static C_{0a}	
RMS0601C7S-300	235	6	1	0.800	6.2	5.3	3	520	925	0.02
RMS0801C7S-300	234	8	1	0.800	8.2	7.3	3	600	1 290	0.02
RMS0801.5C7S-300	228		1.5	1.000	8.3	7.2		810	1 590	
RMS0802C7S-300	224		2	1.200	8.3	7.0		1 070	1 950	
RMS1002C7S-350	262	10	2	1.200	10.3	9.0	3	1 210	2 510	0.02
RMS1202C7S-350	262	12	2	1.200	12.3	11.0	3	1 350	3 190	0.02

Unit: mm

Nut dimensions						Screw shaft dimensions				Lead accuracy			Shaft run-out**	Mass (Kg)	Permissible rotational speed N (min ⁻¹)
D	A	H	B	L_n	W	Effective thread length L_t	Shaft end L_1 d_2		Overall length L_o	Target compensation T	Deviation e_p	Variation v_{300}			
12	24	16	3.5	15	18	250	50	4	300	0	0.085	0.052	0.09	0.075	3 000
14	27	18	4	16	21	250	50	6	300	0	0.085	0.052	0.09	0.13	
15	28	19		22	22									0.14	
16	29	20		26	23									0.15	
18	35	22	5	28	27	290	60	8	350	0	0.085	0.052	0.10	0.25	
20	37	24	5	28	29	290	60	10	350	0	0.085	0.052	0.10	0.35	

- Notes: 1. We recommend NSK support unit (page B389) or support kit (page B401).
 2. **Only rust preventive agent is applied at time of delivery. Please apply lubricant (oil or grease) before use.** See page D13 for details.
 3. Seal is not installed.
 4. Permissible rotational speed is determined by d·n value and critical speed. See pages B47 and B349.

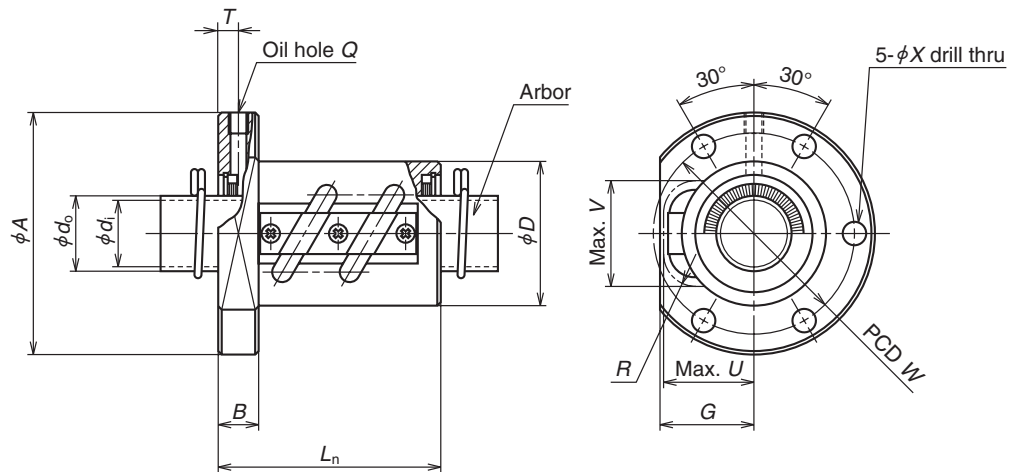

Ball nut No.	Shaft dia. <i>d</i>	Lead <i>l</i>	Ball dia. <i>D_v</i>	Ball circle dia. <i>d_m</i>	Root dia. <i>d_t</i>	Effective turns of balls Turns × Circuits	Basic load rating (N)		Axial play Max.	Ball nut dimensions Outside dia. <i>D</i>
							Dynamic <i>C_a</i>	Static <i>C_{0a}</i>		
RNFTL 1003A3.5	10	3	2.381	10.65	8.1	3.5×1	3 780	6 730	0.10	20
RNFTL 1006A2.5S	10	6	2.381	10.65	8.1	2.5×1	2 830	4 810	0.10	20
RNFTL 1208A2.5S	12	8	2.778	12.65	9.6	2.5×1	3 730	6 560	0.10	25
RNFTL 1404A3.5S	14	4	2.778	14.5	11.5	3.5×1	5 370	10 800	0.10	25
RNFTL 1405A2.5S	14	5	3.175	14.5	11.0	2.5×1	5 260	9 720	0.10	30
RNFTL 1610A2.5	16	10	3.175	16.75	13.3	2.5×1	5 660	11 500	0.10	30
RNFTL 1610A2.5S	16	10	3.175	16.75	13.3	2.5×1	5 660	11 500	0.10	30
RNFTL 1808A3.5	18	8	4.762	18.5	13.6	3.5×1	13 200	25 800	0.15	34
RNFTL 1808A3.5S	18	8	4.762	18.5	13.6	3.5×1	13 200	25 800	0.15	34
RNFTL 2005A2.5	20	5	3.175	20.5	17.0	2.5×1	6 360	14 200	0.10	40
RNFTL 2005A2.5S	20	5	3.175	20.5	17.0	2.5×1	6 360	14 200	0.10	40
RNFTL 2010A2.5	20	10	4.762	21.25	16.2	2.5×1	10 900	21 800	0.15	40
RNFTL 2010A2.5S	20	10	4.762	21.25	16.2	2.5×1	10 900	21 800	0.15	40
RNFTL 2505A5	25	5	3.175	25.5	22.0	2.5×2	12 800	36 300	0.10	42
RNFTL 2505A5S	25	5	3.175	25.5	22.0	2.5×2	12 800	36 300	0.10	42
RNFTL 2510A2.5	25	10	6.35	26	19.0	2.5×1	17 500	35 200	0.20	44
RNFTL 2510A2.5S						2.5×1	17 500	35 200		44
RNFTL 2510A5						2.5×2	31 800	70 300		44
RNFTL 2510A5S						2.5×2	31 800	70 300		44

Notes: 1. Protruding portion of tube does not interfere with ball nut housing if its dimensions corresponding to U and V are large enough.
 2. Actual screw shaft length may become slightly longer than nominal length L_0 due to manufacturing tolerance.
 3. Only ball nut part numbers ending "S" are equipped with seals. External dimensions of those with seals are the same as those without.
 In ball nut side view drawing, above the center line there is a seal, and beneath it there is no seal.
 Seal for those with shaft diameter of 14 mm or less is made of synthetic resin. Seal for those of 16 mm or more is a "Brush" seal.

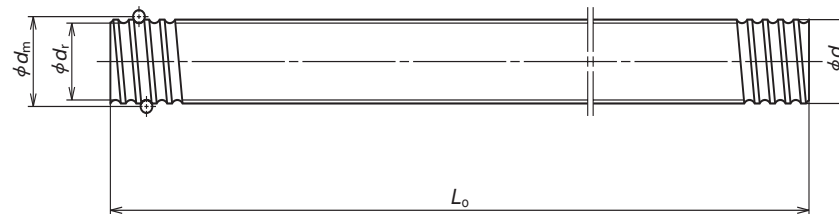

Ball nut dimensions													Nut Mass. (kg)	Arbor		Screw shaft			Shaft mass/m (kg)	Internal spatial volume of nut (cm ³)	Standard volume of grease replenishing (cm ³)
Flange		Length		Bolt hole		Oil hole		Projecting tube			Outside dia.	Bore		Standard length		Screw shaft No.					
A	G	B	L _n	W	X	Q	T	U	V	R	d _o	d	L ₀	L ₀	L ₀	No.					
40	15	6	34	30	4.5	M3×0.5	3.0	15	15	7	0.092	8.1	6.1	400	800	—	RS1003A··	0.50	—	—	
40	15	6	36	30	4.5	M3×0.5	3.5	15	15	5	0.095	8.1	6.1	400	800	—	RS1006A··	0.56	1.1	0.6	
45	19	8	46	35	4.5	M3×0.5	5.5	19	18	7	0.18	9.6	7.6	400	800	—	RS1208A··	0.74	1.8	0.9	
50	19	10	43	40	4.5	M6×1	5.0	19	20	7	0.20	11.5	9.5	500	1 000	—	RS1404A··	1.02	2.0	1.0	
50	22	10	45	40	4.5	M6×1	5.0	22	21	8	0.26	11.0	9.0	500	1 000	—	RS1405A··	1.00	2.4	1.2	
53	23	10	54	41	5.5	M6×1	5.5	23	22.5	8	0.28	13.3	11.3	500	1 000	1 500	RS1610A··	1.37	2.7	1.4	
63	27	12	58	49	6.6	M6×1	6.0	27	27	8	0.43	13.6	11.6	500	1 000	1 500	RS1808A··	1.60	5.2	2.6	
60	28	10	46	50	4.5	M6×1	5.0	28	27	10	0.42	17.0	14.6	500	1 000	2 000	RS2005A··	2.17	3.5	1.8	
67	30	12	59	53	6.6	M6×1	6.0	30	29	12	0.55	16.2	13.8	500	1 000	2 000	RS2010A··	2.18	7.1	3.6	
71	28	12	66	57	6.6	M6×1	6.0	28	31	10	0.62	22.0	19.6	1 000	2 000	2 500	RS2505A··	3.47	6.5	3.3	
80	34	15	62	62	9	M6×1	7.5	34	37	17	0.75	19.0	16.6	1 000	2 000	2 500	RS2510A··	13	6.5		
80	34	15	92	62	9	M6×1	7.5	34	37	17								18		9.0	

4. Nut assembly with arbor and screw shaft are separate at time of delivery.
 5. Value obtained by dividing standard screw shaft length by 100 mm will be entered at end of the part number where marked with ···.
 6. Items in stock do not have surface treatment. For details of standard stock products, contact NSK.
 7. Internal spatial volume of nut and volume of grease to be replenished are values for ball screws with seals. Recommended amount for replenishing is approximately 50% of nut's internal space. For ball screws without seals, apply grease to screw shaft surface or move ball nut by hand while filling them with grease so that grease permeates all areas. See page D16 for details.

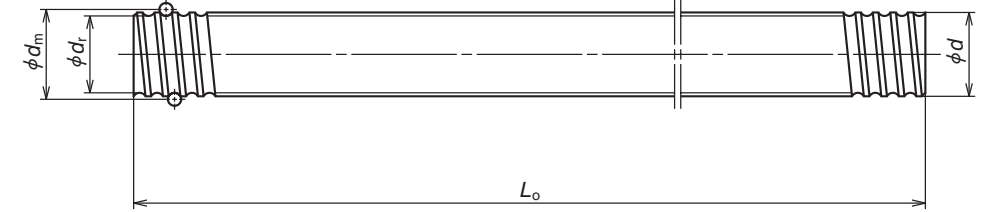
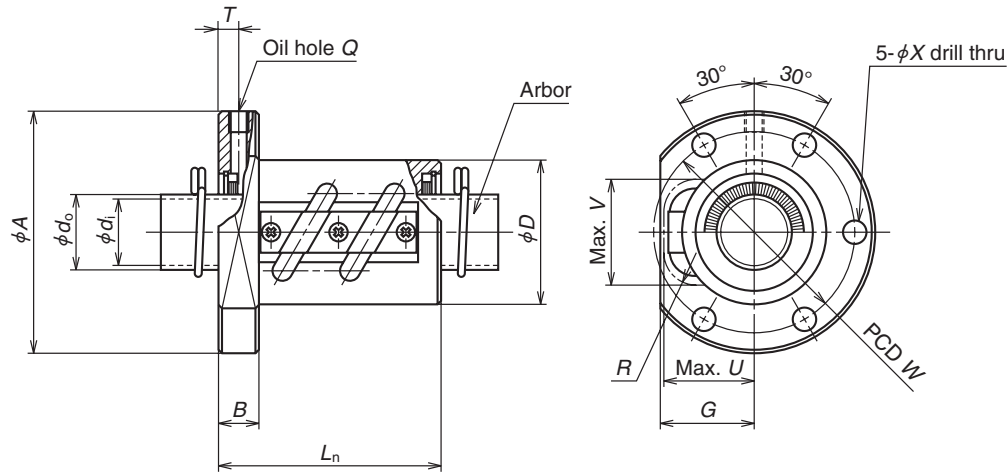

Ball nut No.	Shaft dia. <i>d</i>	Lead <i>l</i>	Ball dia. <i>D_w</i>	Ball circle dia. <i>d_m</i>	Root dia. <i>d_t</i>	Effective turns of balls Turns × Circuits	Basic load rating (N)		Axial play Max.	Ball nut dimensions Outside dia. <i>D</i>
							Dynamic <i>C_a</i>	Static <i>C_{0a}</i>		
RNFTL 2806A2.5 RNFTL 2806A2.5S	28	6	3.175	28.5	25.0	2.5×1	7 430	20 300	0.10	50
RNFTL 2806A5 RNFTL 2806A5S						2.5×2	13 500	40 600		
RNFTL 3210A5 RNFTL 3210A5S	32	10	6.35	33.75	27.0	2.5×2	35 700	92 200	0.20	55
RNFTL 3610A2.5 RNFTL 3610A2.5S	36	10	6.35	37	30.0	2.5×1	21 000	51 000	0.20	60
RNFTL 3610A5 RNFTL 3610A5S						2.5×2	38 100	102 000		
RNFTL 4010A7 RNFTL 4010A7S	40	10	6.35	41.75	35.0	3.5×2	53 500	164 000	0.20	65
RNFTL 4512A5 RNFTL 4512A5S	45	12	7.144	46.5	39.0	2.5×2	49 600	147 000	0.23	70
RNFTL 5010A7 RNFTL 5010A7S	50	10	6.35	51.75	45.0	3.5×2	59 500	205 000	0.20	80
RNFTL 5016A5 RNFTL 5016A5S	50	16	9.525	52	42.0	2.5×2	99 900	293 000	0.23	85

Unit: mm

Ball nut dimensions											Nut Mass. (kg)	Arbor		Screw shaft			Shaft mass/m (kg)	Internal spatial volume of nut (cm ³)	Standard volume of grease replenishing (cm ³)	
Flange		Length		Bolt hole		Oil hole		Projecting tube				Outside dia.	Bore	Standard length						Screw shaft No.
A	G	B	L _n	W	X	Q	T	U	V	R	d ₀	d	L ₀							
79	33	15	55	65	6.6	M6×1	7.5	33	34	10	0.85	25.0	22.6	1 000	2 000	2 500	RS2806A··	4.47	5.9	3.0
79	33	15	79	65	6.6	M6×1	7.5	33	34	10	1.07			8.4	4.2					
97	39	18	97	75	11	M6×1	9.0	39	42	17	1.55	27.0	24.6	1 000	2 000	3 000	RS3210A··	5.53	29	15
102	42	18	68	80	11	M6×1	9.0	42	46	17	1.47	30.0	27.6	1 000	2 000	3 000	RS3610A··	6.91	21	11
102	42	18	98	80	11	M6×1	9.0	42	46	17	1.80			33	17					
114	44	20	120	90	14	M6×1	10.0	44	50	20	2.49	35.0	31.8	2 000	3 000	4 000	RS4010A··	8.87	42	21
130	47	22	116	100	18	M6×1	11.0	47	55	20	3.07	39.0	35.8	2 000	3 000	4 000	RS4512A··	11.16	49	25
140	52	22	122	110	18	M6×1	11.0	52	59	20	4.06	45.0	41.8	2 000	3 000	4 000	RS5010A··	14.15	53	27
163	57	28	146	125	22	M6×1	14.0	57	63	25	6.42	42.0	38.8	2 000	3 000	4 000	RS5016A··	13.48	94	47

Notes: 1. Protruding portion of tube does not interfere with ball nut housing if its dimensions corresponding to U and V are large enough.
 2. Actual screw shaft length may become slightly longer than nominal length L₀ due to manufacturing tolerance.
 3. Only ball nut part numbers ending "S" are equipped with seals. External dimensions of those with seals are the same as those without.
 In ball nut side view drawing, above the center line there is a seal, and beneath it there is no seal.
 Seal for those with shaft diameter of 14 mm or less is made of synthetic resin. Seal for those of 16 mm or more is a "Brush" seal.

4. Nut assembly with arbor and screw shaft are separate at time of delivery.
 5. Value obtained by diving standard screw shaft length by 100 mm will be entered at end of the part number where marked with ··.
 6. Items in stock do not have surface treatment. For details of standard stock products, contact NSK.
 7. Internal spatial volume of nut and volume of grease to be replenished are values for ball screws with seals. Recommended amount for replenishing is approximately 50% of nut's internal space. For ball screws without seals, apply grease to screw shaft surface or move ball nut by hand while filling them with grease so that grease permeates all areas. See page D16 for details.

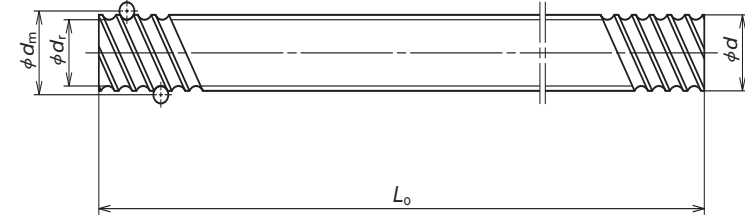
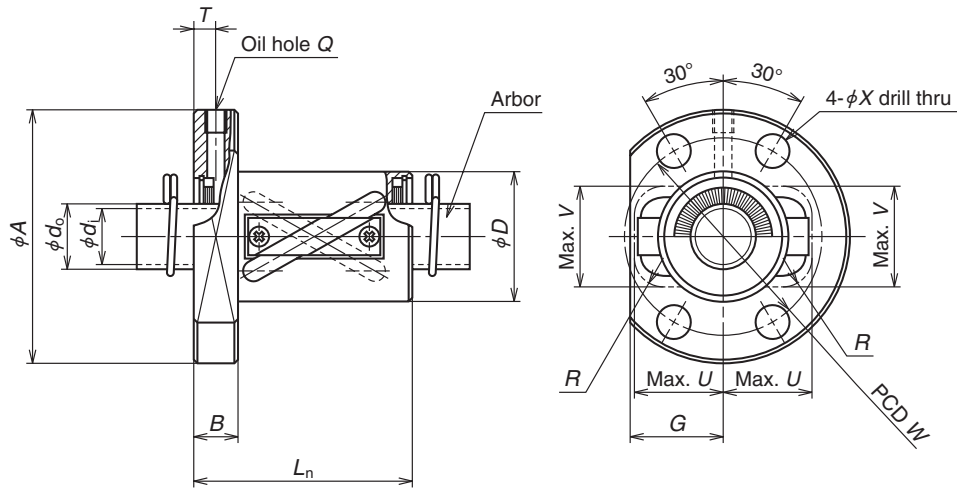

Ball nut No.	Shaft dia. <i>d</i>	Lead <i>l</i>	Ball dia. <i>D_w</i>	Ball circle dia. <i>d_m</i>	Root dia. <i>d_r</i>	Effective turns of balls × Circuits	Basic load rating (N)		Axial play Max.	Ball nut dimensions Outside dia. <i>D</i>
							Dynamic <i>C_a</i>	Static <i>C_{0a}</i>		
RNFTL 1212A3	12	12	2.381	12.65	10.1	1.5 × 2	3 360	6 270	0.10	24
RNFTL 1616A3 RNFTL 1616A3S	16	16	2.778	16.65	13.6	1.5 × 2	4 880	9 650	0.10	30
RNFTL 2020A3 RNFTL 2020A3S	20	20	3.175	20.75	17.3	1.5 × 2	7 010	15 400	0.10	35
RNFTL 2525A3 RNFTL 2525A3S	25	25	3.969	26	22.0	1.5 × 2	10 500	24 100	0.12	45
RNFTL 3232A3 RNFTL 3232A3S	32	32	4.762	33.25	28.0	1.5 × 2	15 300	37 100	0.15	55
RNFTL 4040A3 RNFTL 4040A3S	40	40	6.35	41.75	35.0	1.5 × 2	24 400	61 600	0.20	70

Notes: 1. Protruding portion of tube does not interfere with ball nut housing if its dimensions corresponding to U and V are large enough.
 2. Actual screw shaft length may become slightly longer than nominal length L_0 due to manufacturing tolerance.
 3. Only ball nut part numbers ending "S" are equipped with seals. External dimensions of those with seals are the same as those without.
 In ball nut side view drawing, above the center line there is a seal, and beneath it there is no seal.
 Seal for those with shaft diameter of 14 mm or less is made of synthetic resin. Seal for those of 16 mm or more is a "Brush" seal.

Ball nut dimensions											Nut Mass. (kg)	Arbor		Screw shaft			Shaft mass/m (kg)	Internal spatial volume of nut (cm ³)	Standard volume of grease replenishing (cm ³)	
Flange		Length	Bolt hole		Oil hole		Projecting tube			Outside dia. <i>d_o</i>		Bore <i>d_i</i>	Standard length			Screw shaft No.				
A	G	<i>B</i>	<i>L_n</i>	W	X	Q	T	U	V				R	<i>L₀</i>						
44	17	8	44	34	4.5	M3×0.5	4.0	17	16	5	0.16	10.1	8.1	400	800	-	RS1212A	0.74	1.7	0.9
55	22	10	50	43	6.6	M6×1	5.0	22	22	7	0.29	13.6	11.6	500	1 000	1 500	RS1616A	1.37	2.8	1.4
68	25	12	59	52	9	M6×1	6.0	25	27	8	0.49	17.3	14.9	500	1 000	2 000	RS2020A	2.19	4.9	2.5
80	31	12	69	63	9	M6×1	6.0	31	32	10	0.80	22.0	19.6	1 000	2 000	2 500	RS2525A	3.43	9.1	4.6
100	37	15	84	80	11	M6×1	7.5	37	40	12	1.46	28.0	25.6	1 000	2 000	3 000	RS3232A	5.71	19	9.5
120	46	18	103	95	14	M6×1	9.0	46	49	15	2.69	35.0	31.8	2 000	3 000	4 000	RS4040A	8.82	39	20

4. Nut assembly with arbor and screw shaft are separate at time of delivery.
 5. Value obtained by dividing standard screw shaft length by 100 mm will be entered at end of the part number where marked with · · ·
 6. Items in stock do not have surface treatment. For details of standard stock products, contact NSK.
 7. Internal spatial volume of nut and volume of grease to be replenished are values for ball screws with seals. Recommended amount for replenishing is approximately 50% of nut's internal space. For ball screws without seals, apply grease to screw shaft surface or move ball nut by hand while filling them with grease so that grease permeates all areas. See page D16 for details.

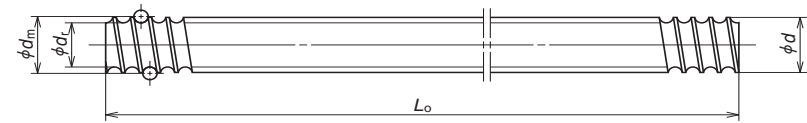
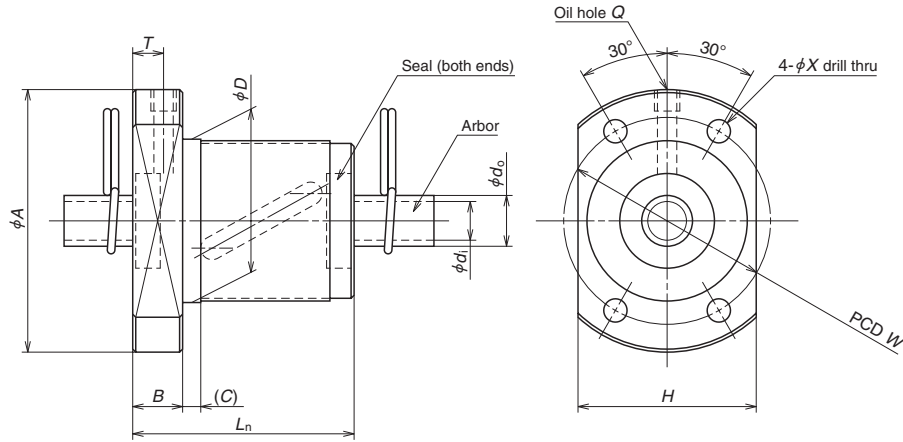

Ball nut No.	Shaft dia. <i>d</i>	Lead <i>l</i>	Ball dia. <i>D_w</i>	Ball circle dia. <i>d_m</i>	Root dia. <i>d_r</i>	Effective turns of balls × Circuits	Basic load rating (N)		Axial play Max.	Ball nut dimensions Outside dia. <i>D</i>
							Dynamic <i>C_a</i>	Static <i>C_{0b}</i>		
RNFBL 1006A2.5S	10	6	2.381	10.65	8.1	2.5×1	2 830	4 810	0.10	26
RNFBL 1208A2.5S	12	8	2.778	12.65	9.6	2.5×1	3 730	6 560	0.10	29
RNFBL 1404A3.5S	14	4	2.778	14.5	11.5	3.5×1	5 370	10 800	0.10	31
RNFBL 1405A2.5S	14	5	3.175	14.5	11.0	2.5×1	5 260	9 720	0.10	32
RNFBL 1808A3.5S	18	8	4.762	18.5	13.6	3.5×1	13 200	25 800	0.15	50
RNFBL 2005A2.5S	20	5	3.175	20.5	17.0	2.5×1	6 360	14 200	0.10	40
RNFBL 2010A2.5S	20	10	4.762	21.25	16.2	2.5×1	10 900	21 800	0.15	52
RNFBL 2505A2.5S	25	5	3.175	25.5	22.0	2.5×1	7 070	18 200	0.10	43
RNFBL 2505A5S						2.5×2	12 800	36 300		
RNFBL 2510A2.5S	25	10	6.35	26	19.0	2.5×1	17 500	35 200	0.20	60
RNFBL 2510A5S						2.5×2	31 800	70 300		
RNFBL 2806A2.5S	28	6	3.175	28.5	25.0	2.5×1	7 430	20 300	0.10	50
RNFBL 2806A5S						2.5×2	13 500	40 600		
RNFBL 3210A2.5S	32	10	6.35	33.75	27.0	2.5×1	19 700	46 100	0.20	67
RNFBL 3210A5S						2.5×2	35 700	92 200		
RNFBL 3610A2.5S	36	10	6.35	37	30.0	2.5×1	21 000	51 000	0.20	70
RNFBL 3610A5S						2.5×2	38 100	102 000		
RNFBL 4010A5S	40	10	6.35	41.75	35.0	2.5×2	40 100	116 000	0.20	76

- Notes: 1. Actual screw shaft length may become slightly longer than nominal length L_0 due to manufacturing tolerance.
 2. Nut assembly with arbor and screw shaft are separate at time of delivery.
 3. Value obtained by diving standard screw shaft length by 100 mm will be entered at end of the part number where marked with ...

Ball nut dimensions										Arbor		Screw shaft				Shaft mass/m (kg)	Internal spatial volume of nut (cm ³)	Standard volume of grease replenishing (cm ³)
Flange		Length		Bolt hole		Oil hole		Nut Mass (kg)	Outside dia. d_0	Bore d_1	Standard length			Screw shaft No.				
<i>A</i>	<i>H</i>	<i>B</i>	Overall length L_n	<i>C</i>	<i>W</i>	<i>X</i>	<i>Q</i>				<i>T</i>	L_0						
42	29	8	36	3	34	4.5	M3×0.5	5.0	0.16	8.1	6.1	400	800	-	RS1006A...	0.56	1.1	0.6
45	32	8	44	3	37	4.5	M3×0.5	5.5	0.21	9.6	7.6	400	800	-	RS1208A...	0.81	1.6	0.8
50	37	10	40	4	40	4.5	M6×1	5.0	0.25	11.5	9.5	500	1 000	-	RS1404A...	1.02	2.4	1.2
50	38	10	40	4	40	4.5	M6×1	5.0	0.26	11.0	9.0	500	1 000	-	RS1405A...	1.00	1.9	1.0
80	60	12	61	4	65	6.6	M6×1	6.0	1.00	13.6	11.6	500	1 000	1 500	RS1808A...	1.60	5.8	2.9
60	46	10	40	4	50	4.5	M6×1	5.0	0.37	17.0	14.6	500	1 000	2 000	RS2005A...	2.17	2.8	1.4
82	64	12	61	5	67	6.6	M6×1	6.0	1.05	16.2	13.8	500	1 000	2 000	RS2010A...	2.18	7.6	3.8
67	50	10	40	4	55	5.5	M6×1	5.0	0.40	22.0	19.6	1 000	2 000	2 500	RS2505A...	3.47	3.5	1.8
			55	4	55	5.5	M6×1	5.0	0.50								4.7	2.4
96	72	15	66	5	78	9.0	M6×1	7.5	1.52	19.0	16.6	1 000	2 000	2 500	RS2510A...	3.13	14	7.0
			96	5	78	9.0	M6×1	7.5	1.99								19	9.5
80	60	12	47	5	65	6.6	M6×1	6.0	0.70	25.0	22.6	1 000	2 000	2 500	RS2806A...	4.47	4.5	2.3
			65	5	65	6.6	M6×1	6.0	0.87								7.6	3.8
103	78	15	67	5	85	9.0	M6×1	7.5	1.72	27.0	24.6	1 000	2 000	3 000	RS3210A...	5.53	20	10
			97	5	85	9.0	M6×1	7.5	2.25								28	14
110	82	17	69	5	90	11.0	M6×1	8.5	1.97	30.0	27.6	1 000	2 000	3 000	RS3610A...	6.91	21	11
			99	5	90	11.0	M6×1	8.5	2.53								29	15
116	88	17	99	5	96	11.0	M6×1	8.5	2.86	35.0	31.8	2 000	3 000	4 000	RS4010A...	8.87	36	18

4. Items in stock do not have surface treatment. For details of standard stock products, contact NSK.
 5. Seal for those with shaft diameter of 14 mm or less is made of synthetic resin. Seal for those of 16 mm or more is a "Brush" seal.
 6. Recommended quantity of grease is about 50% of ball nut's internal space. See page D16 for details.

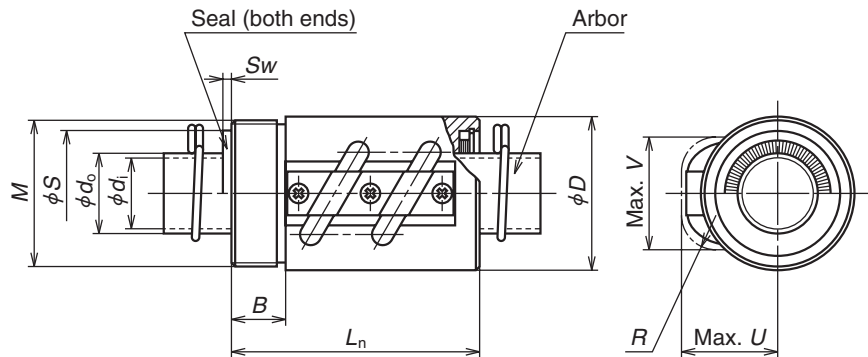

Ball nut No.	Shaft dia. <i>d</i>	Lead <i>l</i>	Ball dia. <i>D_w</i>	Ball circle dia. <i>d_m</i>	Root dia. <i>d_r</i>	Effective turns of balls × Circuits	Basic load rating (N)		Axial play Max.	Ball nut dimensions	
							Dynamic <i>C_a</i>	Static <i>C_{sa}</i>		Outside dia. <i>D</i>	
RNCT 1003A3.5	10	3	2.381	10.65	8.1	3.5 × 1	3 780	6 730	0.10	20	
RNCT 1404A3.5S	14	4	2.778	14.5	11.5	3.5 × 1	5 370	10 800	0.10	25	
RNCT 1405A2.5S	14	5	3.175	14.5	11.0	2.5 × 1	5 260	9 720	0.10	30	
RNCT 1808A3.5	18	8	4.762	18.5	13.6	3.5 × 1	13 200	25 800	0.15	34	
RNCT 2005A2.5	20	5	3.175	20.5	17.0	2.5 × 1	6 360	14 200	0.10	40	
RNCT 2505A5	25	5	3.175	25.5	22.0	2.5 × 2	12 800	36 300	0.10	42	
RNCT 2510A5	25	10	6.35	26	19.0	2.5 × 2	31 800	70 300	0.20	44	
RNCT 2806A5	28	6	3.175	28.5	25.0	2.5 × 2	13 500	40 600	0.10	50	
RNCT 3210A5	32	10	6.35	33.75	27.0	2.5 × 2	35 700	92 200	0.20	55	
RNCT 3610A5	36	10	6.35	37	30.0	2.5 × 2	38 100	102 000	0.20	60	
RNCT 4010A7	40	10	6.35	41.75	35.0	3.5 × 2	53 500	164 000	0.20	65	
RNCT 4512A5	45	12	7.144	46.5	39.0	2.5 × 2	49 600	147 000	0.23	70	
RNCT 5010A7	50	10	6.35	51.75	45.0	3.5 × 2	59 500	205 000	0.20	80	
RNCT 5016A5	50	16	9.525	52	42.0	2.5 × 2	99 900	293 000	0.23	85	

Notes: 1. Protruding portion of tube does not interfere with ball nut housing if its dimensions corresponding to U and V are large enough.
 2. Actual screw shaft length may become slightly longer than nominal length *L_s* due to manufacturing tolerance.
 3. Only ball nut part numbers ending "S" are equipped with seals. External dimensions of those with seals are the same as those without.
 In ball nut side view drawing, above the center line there is a seal, and beneath it there is no seal.
 Seal for those with shaft diameter of 14 mm or less is made of synthetic resin. Seal for those of 16 mm or more is a "Brush" seal.

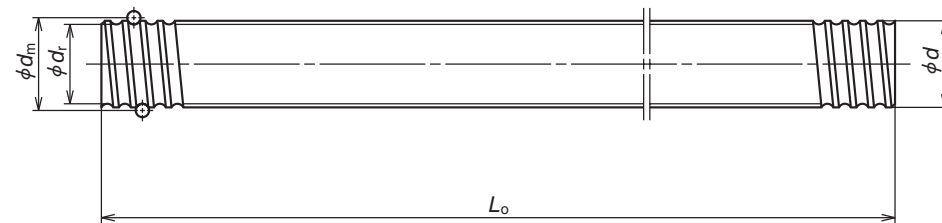

Unit: mm

Ball nut dimensions						Nut Mass. (kg)	Seal dimensions		Arbor		Screw shaft			Shaft mass/m (kg)	Internal spatial volume of nut (cm ³)	Standard volume of grease replenishing (cm ³)	
V-thread		Length	Projecting tube				Diameter	Thickness	Outside dia.	Bore	Standard length						Screw shaft No.
<i>M</i>	<i>B</i>		<i>L_n</i>	<i>U</i>	<i>V</i>						<i>R</i>	<i>L_s</i>					
M18 × 1	10	38	15	15	7	0.049	-	-	8.1	6.1	400	800	-	RS1003A	0.50	-	-
M24 × 1	10	43	19	20	7	0.083	-	-	11.5	9.5	500	1 000	-	RS1404A	1.02	2.7	1.4
M26 × 1.5	10	45	22	21	8	0.15	-	-	11.0	9.0	500	1 000	-	RS1405A	1.00	3.1	1.6
M32 × 1.5	12	58	27	27	8	0.21	28.5	2.5	13.6	11.6	500	1 000	1 500	RS1808A	1.60	6.6	3.3
M36 × 1.5	12	48	28	27	10	0.28	29.5	2.5	17.0	14.6	500	1 000	2 000	RS2005A	2.17	4.8	2.4
M40 × 1.5	15	69	28	31	10	0.38	34.5	2.5	22.0	19.6	1 000	2 000	2 500	RS2505A	3.47	8.4	4.2
M42 × 1.5	15	92	34	37	17	0.49	38.5	2.5	19.0	16.6	1 000	2 000	2 500	RS2510A	3.13	21	1
M45 × 1.5	15	79	33	34	10	0.68	37.5	2.5	25.0	22.6	1 000	2 000	2 500	RS2806A	4.47	9.7	4.9
M50 × 1.5	18	97	39	42	17	0.79	45.5	2.5	27.0	24.6	1 000	2 000	3 000	RS3210A	5.53	32	16
M55 × 2	18	98	42	46	17	0.97	50.5	3.0	30.0	27.6	1 000	2 000	3 000	RS3610A	6.91	32	16
M60 × 2	25	125	44	50	20	1.37	54.5	3.0	35.0	31.8	2 000	3 000	4 000	RS4010A	8.87	51	26
M65 × 2	30	124	47	55	20	1.42	60.5	3.0	39.0	35.8	2 000	3 000	4 000	RS4512A	11.16	60	30
M75 × 2	40	140	52	59	20	2.41	64.5	3.0	45.0	41.8	2 000	3 000	4 000	RS5010A	14.15	76	38
M80 × 2	40	158	57	63	25	3.14	68.5	3.0	42.0	38.8	2 000	3 000	4 000	RS5016A	13.48	114	57

4. Nut assembly with arbor and screw shaft are separate at time of delivery.
 5. Value obtained by dividing standard screw shaft length by 100 mm will be entered at end of the part number where marked with · · ·
 6. Items in stock do not have surface treatment. For details of standard stock products, contact NSK.
 7. Internal spatial volume of nut and volume of grease to be replenished are values for ball screws with seals. Recommended amount for replenishing is approximately 50% of nut's internal space. For ball screws without seals, apply grease to screw shaft surface or move ball nut by hand while filling them with grease so that grease permeates all areas. See page D16 for details.

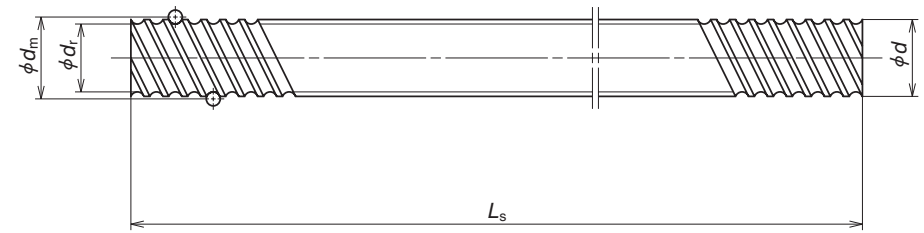
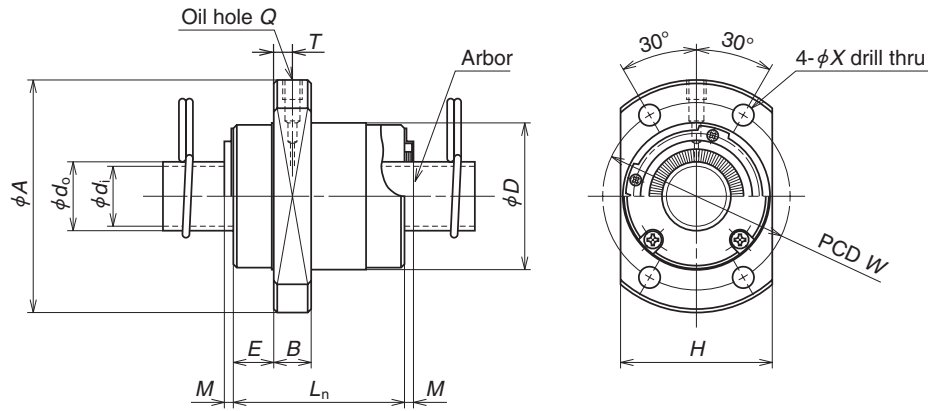

Unit: mm

Ball nut No.	Shaft dia. <i>d</i>	Lead <i>l</i>	Ball dia. <i>D_w</i>	Ball circle dia. <i>d_m</i>	Root dia. <i>d_r</i>	Effective turns of balls × Circuits	Basic load rating (N)		Axial play Max.	Ball nut dimensions Outside dia. <i>D</i>
							Dynamic <i>C_d</i>	Static <i>C_s</i>		
RNFCL 1212A3 RNFCL 1212A6	12	12	2.381	12.65	10.1	1.7 × 2 1.7 × 4	3 740 6 780	6 640 13 300	0.10	26
RNFCL 1520A3 RNFCL 1520A6S	15	20	3.175	15.5	12.2	1.7 × 2	6 730	12 300	0.10	33
RNFCL 1616A3 RNFCL 1616A3S RNFCL 1616A6 RNFCL 1616A6S	16	16	2.778	16.65	13.5	1.7 × 2 1.7 × 4	5 430 9 860	10 400 20 800	0.10	32
RNFCL 2020A3 RNFCL 2020A3S RNFCL 2020A6 RNFCL 2020A6S	20	20	3.175	20.75	17.3	1.7 × 2 1.7 × 4	7 810 14 200	16 500 33 000	0.10	39
RNFCL 2525A3 RNFCL 2525A3S RNFCL 2525A6 RNFCL 2525A6S	25	25	3.969	26	22.0	1.7 × 2 1.7 × 4	11 700 21 200	25 800 51 500	0.12	47
RNFCL 3232A3 RNFCL 3232A3S RNFCL 3232A6 RNFCL 3232A6S	32	32	4.762	33.25	28.0	1.7 × 2 1.7 × 4	17 100 31 000	40 500 81 000	0.15	58
RNFCL 4040A3 RNFCL 4040A3S RNFCL 4040A6 RNFCL 4040A6S	40	40	6.35	41.75	35.0	1.7 × 2 1.7 × 4	27 200 49 300	67 900 136 000	0.20	73
RNFCL 5050A3 RNFCL 5050A3S RNFCL 5050A6 RNFCL 5050A6S	50	50	7.938	52.25	44.0	1.7 × 2 1.7 × 4	40 600 73 700	106 000 212 000	0.25	90

- Notes: 1. Actual screw shaft length may become slightly longer than nominal length L_0 due to manufacturing tolerance.
 2. Nut assembly with arbor and screw shaft are separate at time of delivery.
 3. Value obtained by dividing the standard screw shaft length by 100 mm will be entered at end of the part number where marked with : .
 4. Items in stock do not have surface treatment. For details of standard stock products, contact NSK.
 5. Length of nut becomes longer (2 x M) for those with "brush" seals.

Ball nut dimensions										Nut Mass. (kg)	Arbor		Screw shaft			Shaft mass (kg)	Internal spatial volume of nut (cm ³)	Stand- ard volume of grease replenishing (cm ³)	
Flange		Length			Bolt hole		Oil hole		Outside dia. <i>d_o</i>		Bore <i>d_i</i>	Standard length			Screw shaft No.				
<i>A</i>	<i>H</i>	<i>B</i>	<i>E</i>	<i>L_n</i>	<i>M</i>	<i>W</i>	<i>X</i>	<i>Q</i>		<i>T</i>		<i>L_s</i>							
44	28	6	9	30	-	35	4.5	M3 × 0.5	3.0	0.12	10.1	8.1	400	800	-	RS1212A	0.74	-	-
51	35	10	11	45	-	42	4.5	M6 × 1	5.0	0.28	12.2	10.2	500	1 000	1 500	RS1520A	1.15	3.3	1.7
53	34	10	10	38	3	42	4.5	M6 × 1	5.0	0.23	13.5	11.5	500	1 000	1 500	RS1616A	1.37	2.6	1.3
62	41	10	11.5	46	3	50	5.5	M6 × 1	5.0	0.37	17.3	14.9	500	1 000	2 000	RS2020A	2.19	4.4	2.2
74	49	12	13	55	3	60	6.6	M6 × 1	6.0	0.62	22.0	19.6	1 000	2 000	2 500	RS2525A	3.43	8.2	4.1
92	60	12	16	70	3	74	9	M6 × 1	5.5	1.10	28.0	25.6	1 000	2 000	3 000	RS3232A	5.71	16	8.0
114	75	15	19.5	85	3.5	93	11	M6 × 1	6.5	2.09	35.0	31.8	2 000	3 000	4 000	RS4040A	8.82	32	16
135	92	20	21.5	107	3.5	112	14	M6 × 1	7.0	3.90	44.0	40.8	2 000	3 000	4 000	RS5050A	13.81	64	32

6. Internal spatial volume of nut and volume of grease to be replenished are values for ball screws with seals. Recommended amount for replenishing is approximately 50% of nut's internal space. For ball screws without seals, apply grease to screw shaft surface or move ball nut by hand while filling them with grease so that grease permeates all areas. See page D16 for details.

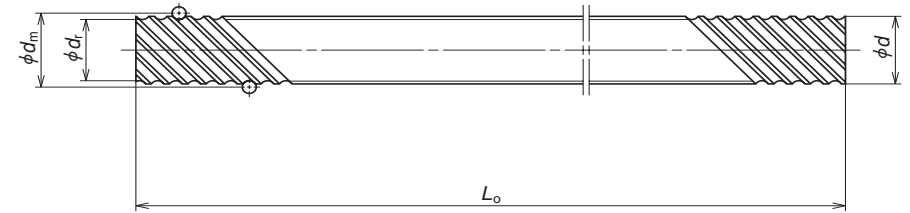
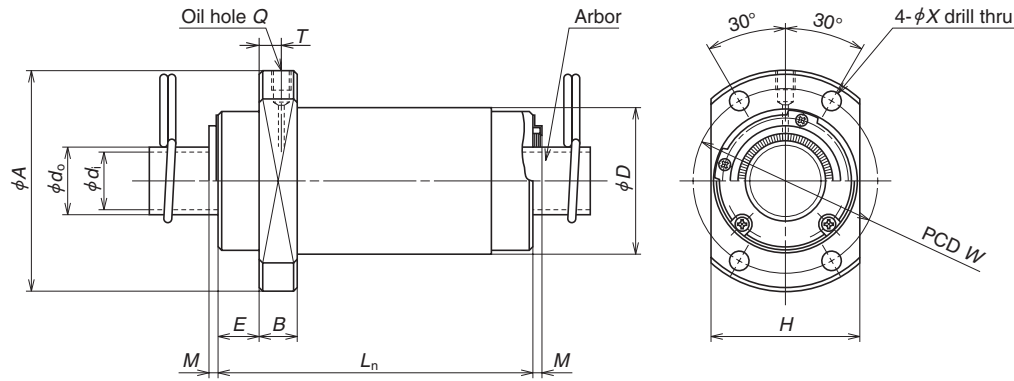

Unit: mm

Ball nut No.	Shaft dia. <i>d</i>	Lead <i>l</i>	Ball dia. <i>D_w</i>	Ball circle dia. <i>d_m</i>	Root dia. <i>d_r</i>	Effective turns of balls × Circuits	Basic load rating (N)		Axial play Max.	Ball nut dimensions	
							Dynamic <i>C_a</i>	Static <i>C_{0a}</i>		Outside dia. <i>D</i>	
RFNCL 1632A2 RFNCL 1632A2S	16	32	2.778	16.65	13.5	0.7 × 4	4 600	8 460	0.10	32	
RFNCL 1632A3 RFNCL 1632A3S						1.7 × 2	5 430	10 400			
RFNCL 1632A6 RFNCL 1632A6S						1.7 × 4	9 860	20 800			
RFNCL 2040A2 RFNCL 2040A2S	20	40	3.175	20.75	17.3	0.7 × 4	6 610	13 600	0.10	38	
RFNCL 2040A3 RFNCL 2040A3S						1.7 × 2	7 810	16 500			
RFNCL 2040A6 RFNCL 2040A6S						1.7 × 4	14 200	33 000			
RFNCL 2550A2 RFNCL 2550A2S	25	50	3.969	26	22.0	0.7 × 4	9 870	21 200	0.12	46	
RFNCL 2550A3 RFNCL 2550A3S						1.7 × 2	11 700	25 800			
RFNCL 2550A6 RFNCL 2550A6S						1.7 × 4	21 200	51 500			
RFNCL 3264A3 RFNCL 3264A3S	32	64	4.762	33.25	28.0	1.7 × 2	17 100	40 500	0.15	58	
RFNCL 3264A6 RFNCL 3264A6S						1.7 × 4	31 000	81 000			
RFNCL 4080A3 RFNCL 4080A3S						1.7 × 2	27 200	67 900			
RFNCL 4080A6 RFNCL 4080A6S	40	80	6.350	41.75	35.0	1.7 × 4	49 300	136 000	0.20	73	

Ball nut dimensions										Nut Mass. (kg)	Arbor		Screw shaft				Shaft mass/m (kg)	Internal spatial volume of nut (cm ³)	Standard volume of grease replenishing (cm ³)	
Flange		Length			Bolt hole		Oil hole		Outside dia. <i>d_o</i>		Bore <i>d_i</i>	Standard length			Screw shaft No.					
<i>A</i>	<i>H</i>	<i>B</i>	<i>E</i>	<i>L_n</i>	<i>M</i>	<i>W</i>	<i>X</i>	<i>Q</i>		<i>T</i>		<i>L₀</i>								
50	34	10	10	34	—	41	4.5	M6 × 1	5.5	0.21	13.5	11.5	500	1 000	1 500	—	RS1632A··	1.34	2.4	1.2
				66	—					0.33									3.9	2.0
				66	3					0.33									4.1	2.1
58	40	10	11	41	—	48	5.5	M6 × 1	5.5	0.31	17.3	14.9	500	1 000	1 500	2 000	RS2040A··	2.15	4.1	2.1
				81	—					0.53									6.3	3.2
				81	3					0.53									7.0	3.5
70	48	12	13	50	—	58	6.6	M6 × 1	7.0	0.53	22.0	19.6	1 000	2 000	2 500	—	RS2550A··	3.37	8.4	4.2
				100	—					0.91									14	7.0
				100	3					0.91									15	7.5
92	60	12	15.5	126	—	74	9	M6 × 1	7.5	1.76	28.0	25.6	1 000	2 000	3 000	4 000	RS3264A··	5.63	24	12
				—	3					—									26	13
				—	3					—									—	—
114	75	15	19	158	—	93	11	M6 × 1	10.0	3.44	35.0	31.8	2 000	3 000	4 000	5 000	RS4080A··	8.69	52	26
				—	3.5					—									55	28
				—	3.5					—									—	—

- Actual screw shaft length may become slightly longer than nominal length *L₀* due to manufacturing tolerance.
- Nut assembly with arbor and screw shaft are separate at time of delivery.
- Value obtained by dividing the standard screw shaft length by 100 mm will be entered at end of the part number where marked with ··.
- Items in stock do not have surface treatment. For details of standard stock products, contact NSK.
- Length of nut becomes longer (2 × *M*) for those with "brush" seals.

- Internal spatial volume of nut and volume of grease to be replenished are values for ball screws with seals. Recommended amount for replenishing is approximately 50% of nut's internal space. For ball screws without seals, apply grease to screw shaft surface or move ball nut by hand while filling them with grease so that grease permeates all areas. See page D16 for details.

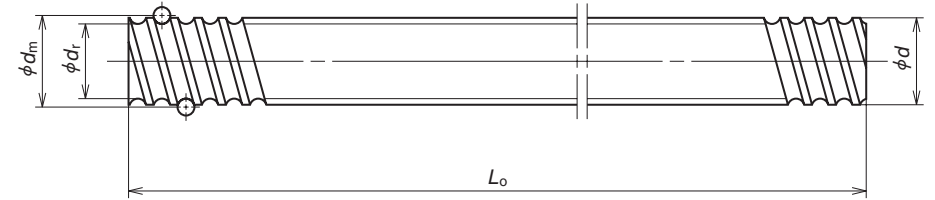
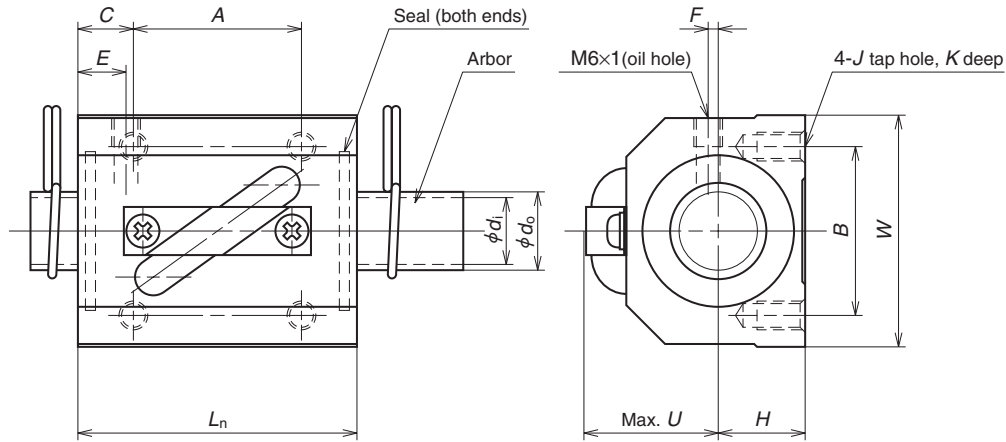

Ball nut No.	Shaft dia. <i>d</i>	Lead <i>l</i>	Ball dia. <i>D_w</i>	Ball circle dia. <i>d_m</i>	Root dia. <i>d_r</i>	Effective turns of balls × Circuits	Basic load rating (N)		Axial play Max.	Ball nut dimensions Length <i>L_n</i>
							Dynamic <i>C_d</i>	Static <i>C_{st}</i>		
							RNSTL 1404A3.5S	14		
RNSTL 1405A2.5S	14	5	3.175	14.5	11.0	2.5 × 1	5 260	9 720	0.10	38
RNSTL 1808A3.5S	18	8	4.762	18.5	13.6	3.5 × 1	13 200	25 800	0.15	56
RNSTL 2005A2.5S	20	5	3.175	20.5	17.0	2.5 × 1	6 360	14 200	0.10	38
RNSTL 2010A2.5S	20	10	4.762	21.25	16.2	2.5 × 1	10 900	21 800	0.15	58
RNSTL 2505A2.5S	25	5	3.175	25.5	22.0	2.5 × 1	7 070	18 200	0.10	35
RNSTL 2510A5S	25	10	6.35	26	19.0	2.5 × 2	31 800	70 300	0.20	94
RNSTL 2806A2.5S	28	6	3.175	28.5	25.0	2.5 × 1	7 430	20 300	0.10	42
RNSTL 2806A5S						2.5 × 2	13 500	40 600		67
RNSTL 3210A2.5S	32	10	6.35	33.75	27.0	2.5 × 1	19 700	46 100	0.20	64
RNSTL 3210A5S						2.5 × 2	35 700	92 200		94
RNSTL 3610A2.5S	36	10	6.35	37	30.0	2.5 × 1	21 000	51 000	0.20	64
RNSTL 3610A5S						2.5 × 2	38 100	102 000		96
RNSTL 4512A5S	45	12	7.144	46.5	39.0	2.5 × 2	49 600	147 000	0.23	115

Notes: 1. Actual screw shaft length may become slightly longer than nominal length *L_n* due to manufacturing tolerance.
 2. Nut assembly with arbor and screw shaft are separate at time of delivery.
 3. Value obtained by dividing the standard screw shaft length by 100 mm will be entered at end of the part number where marked with ··

Ball nut dimensions											Nut Mass. (kg)	Arbor		Screw shaft				Shaft mass/m (kg)	Internal spatial volume of nut (cm ³)	Standard volume of grease replenishing (cm ³)
Width <i>W</i>	Center height <i>H</i>	Bolt hole					Oil hole			Nut Mass. (kg)		Outside dia. <i>d_o</i>	Bore <i>d_i</i>	Standard length		Screw shaft No.				
		<i>A</i>	<i>B</i>	<i>C</i>	<i>J</i>	<i>K</i>	<i>E</i>	<i>F</i>	<i>U</i>					<i>L_s</i>						
34	13	22	26	8	M4	7	7	3	20	0.20	11.5	9.5	500	1 000	-	RS1404A··	1.02	1.6	0.8	
34	13	22	26	8	M4	7	7	3	21	0.20	11.0	9.0	500	1 000	-	RS1405A··	1.00	1.8	0.9	
48	17	35	35	10.5	M6	10	8	3	26	0.31	13.6	11.6	500	1 000	1 500	RS1808A··	1.60	3.4	1.7	
48	17	22	35	8	M6	9	6	2	27	0.24	17.0	14.6	500	1 000	2 000	RS2005A··	2.17	2.5	1.3	
48	18	35	35	11.5	M6	10	10	2	28	0.35	16.2	13.8	500	1 000	2 000	RS2010A··	2.18	6.3	3.2	
60	20	22	40	6.5	M8	10	6	0	27	0.31	22.0	19.6	1 000	2 000	2 500	RS2505A··	3.47	2.6	1.3	
60	23	60	40	17	M8	12	10	0	32	1.32	19.0	16.6	1 000	2 000	2 500	RS2510A··	3.13	18	9.0	
60	22	18	40	12	M8	12	8	0	32	0.65	25.0	22.6	1 000	2 000	2 500	RS2806A··	4.47	3.5	1.8	
60	22	40	40	13.5						1.04										7.0
70	26	45	50	9.5	M8	12	10	0	38	1.12	27.0	24.6	1 000	2 000	3 000	RS3210A··	5.53	18	9.0	
70	26	60	50	17						1.75										27
86	29	45	60	9.5	M10	16	11	0	41	1.76	30.0	27.6	1 000	2 000	3 000	RS3610A··	6.91	18	9.0	
86	29	60	60	18						2.64										27
100	36	75	75	20	M12	20	13	0	46	1.22	39.0	35.8	2 000	3 000	4 000	RS4512A··	11.16	47	24	

4. Items in stock do not have surface treatment. For details of standard stock products, contact NSK.
 5. Seal for those with shaft diameter of 14 mm or less is made of synthetic resin. Seal for those of 16 mm or more is a "Brush" seal.
 6. Recommended quantity of grease is about 50% of ball nut's internal space. See page D16 for details.

B-3-1.7 Accessories

Accessories to use with NSK ball screws are available.

Table 1 Support unit categories

Application	Shape	Support side	Bearing in use	Bearing bore, Bearing seat diameter	Page
Small equipment, light load	Square	Fixed support side	WBK**-01*	Angular contact ball bearing $\phi 4 - \phi 25$	B395 -
			WBK**S-01*	Deep groove ball bearing $\phi 6 - \phi 25$	B399 -
		Simple support side	WBK**SF-01	Deep groove ball bearing $\phi 12, \phi 15$ <small>(exclusive for VFA type)</small>	B402

Application	Shape	Support side	Bearing in use	Bearing bore, Bearing seat diameter	Page
Small equipment, light load	Round	Fixed support side	WBK**R-11 (Support kit)	Deep groove ball bearing (arranged to have angular contact) $\phi 4, \phi 6$ <small>(exclusive for RMA and RMS types)</small>	B401
			WBK**-11*	Angular contact ball bearing $\phi 4 - \phi 25$	B397 -
Machine tools, high speed, heavy load	Round	Fixed support side	WBK**DF*-31H	Thrust angular contact ball bearing $\phi 17 - \phi 40$	B407 -

1. Classification

Ball screw support units are classified into categories by their shape (Table 1). Select the type that best suits your particular needs.

2. Features

●Bearings and seals

On the fixed support side, the angular contact ball bearing is used. It has great rigidity and low friction torque, which match the rigidity of the ball screw. The thrust angular contact ball bearing with high precision and great rigidity is another choice for the fixed support side.

An oil seal is installed to the fixed support side used with an angular contact ball bearing. Fine clearance may occur with this seal.

A deep-groove ball bearing with a shield on both sides is used on the simple support side.

●Lock nut is provided.

A lock nut with fine grade finish is provided to fix the bearing with high precision.

The lock nuts are designed to be difficult to loosen, but they can still loosen if subjected to strong mechanical vibration. If necessary, this should be prevented by applying threadlocking adhesive or taking similar precautions.

3. Reference number coding

(For light load)

Example: **WBK 08 S - 01 A**

Product code for support unit

Nominal size code*

Mounting code

No code: Fixed support unit

S: Simple support unit

SF: Simple support unit (for FSS and VFA)

R: Fixed support unit (support kit for miniature ball screws)

No code or A: For general use

B: Low-profile type (only for square type)

C: For clean environment use

M: Miniature general-purpose use

W: Lost-wax product

01: Square type

11: Round type

*) In case of simple support unit, please note that the nominal size code of 12 or less does not strictly represent internal bore of bearing in millimeters. Please refer to the dimensional table for internal bore of bearing.

(For high speed and heavy load)

Example: **WBK 25 DF - 31H**

Product code for support unit

Nominal size code (internal bore of bearing)

H: High speed type

Bearing combination code

DF: Face to face duplex combination

DFD: Face to face triplex combination

DFF: Face to face quadruplex combination

(1) Support Units for Light Load and Small Equipment

Support units for light load and small equipment provide both fixed and support side bearing assemblies to support screw shafts. They provide all required parts such as bearing locknuts so that you can mount them directly to NSK standard ball screws, of which shaft ends are machined.

Please refer to the dimensions listed on the dimension table for the configuration of standard screw shaft ends for NSK standard ball screws with blank shaft ends. For ball screws for transfer equipment, you require optional spacers when mounting fixed support side support units.

(a) Features

- Prompt delivery
Support units are standard products.
- Best selection of bearings for your application
General use support units for fixed support side are equipped with highly rigid angular contact ball bearings that have been assembled with proper preload, and packed with the appropriate volume of grease. On the other hand, clean support units for fixed support side uses low dust emission grease, and low torque special bearings. Sealed deep groove ball bearings are used for simple support side units for both general and clean environment use.

Accessories

● **Accessories**

Support units provide everything necessary for mounting ball screws to machines. (Please refer to the table below.)

* Do not disassemble fixed support side units as they are equipped with bearings and oil seals.

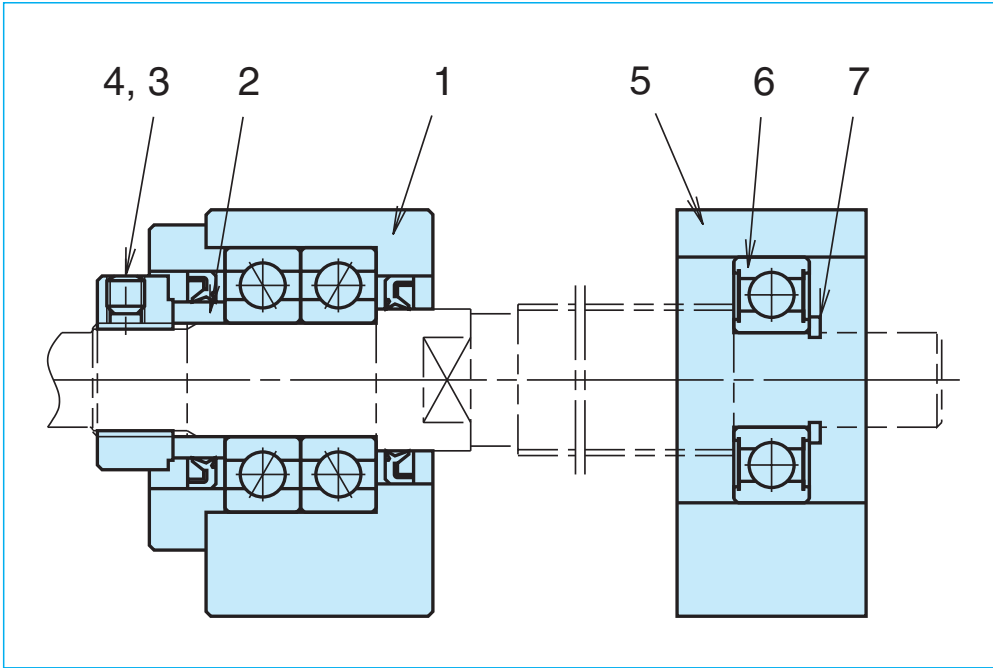

● **Antirust treatment**

The table on the right shows the surface treatment for the bearing housing, and material of small parts.

Fixed support side		Simple support side	
Part No.	Name of parts	Part No.	Name of parts
1	Bearing housing	5	Bearing housing
2	Spacer	6	Bearing
3	Locknut	7	Snap ring
4	Set screw with brass pad		

General support unit	
Bearings and grease	Angular contact ball bearings, PS2
Surface treatment	Black oxide
Screws and snap rings	Standard material

(b) Features of Clean Support Unit

● **Outstanding low dust emission**

Clean support unit uses "NSK clean grease LG2" which has a proven feature of low dust emission. It reduces dust emission to 1/10 of general support units.

● **Low torque**

It features low torque characteristics because of special bearings. (50% lower than general support unit.)

● **High antirust specification**

Low temperature chrome plating is applied to bearing housings, retaining plates, locknuts and spacers to improve antirust properties. Moreover, bolts and snap rings are made of stainless steel. The table below shows the surface treatment of the bearing housing and material of small parts.

	Clean support unit
Bearing • grease	Special bearings, LG2
Surface treatment	Low temperature chrome plating
Set screw and snap ring material	Stainless steel

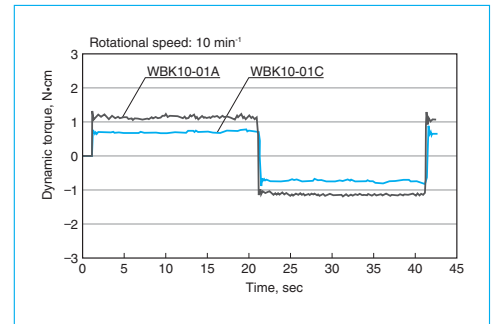
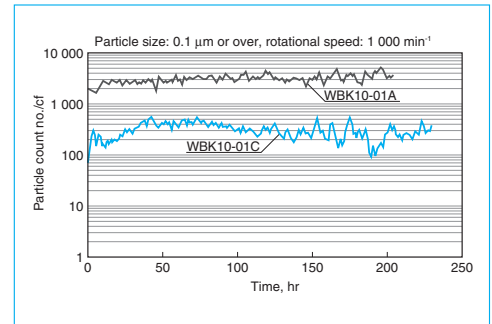

Support Units for Light Load and Small Equipment

WBK**-01M

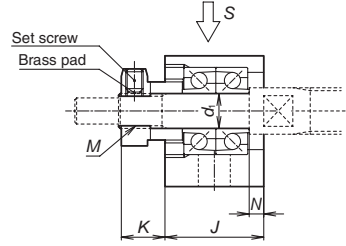
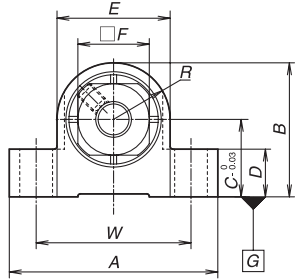

WBK**-01*

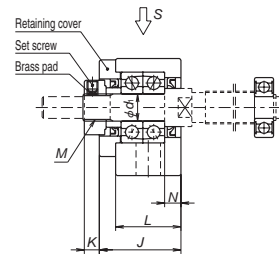
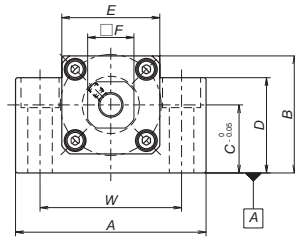

Fixed support side support unit (square type)

Reference No.	Use	d_i	A	B	C	D	E	F	L	J	K	R
WBK04-01M	General	4	27	17	10	6	14	10	—	14	5.5	7
WBK06-01M	General	6	35	22.5	13	8	19	12	—	17	7.5	9.5
WBK06-01A ^{*1}	General	6	42	25	13	20	18	12	20	20	5.5	—
WBK08-01A ^{*1}	General	8	52	32	17	26	25	14	23	23	7	—
WBK08-01B	Low type		62	31	15.5	31	—		21.5	25.5	4.5	
WBK08-01C ^{*1}	Clean environment		52	32	17	26	25		23	23	7	
WBK10-01A	General	10	70	43	25	35	36	17	24	30	5.5	—
WBK10-01B	Low type			38	20	38	—					
WBK10-01C	Clean environment			43	25	35	36					
WBK12-01A	General	12	70	43	25	35	36	19	24	30	5.5	—
WBK12-01B	Low type			38	20	38	—					
WBK12-01C	Clean environment			43	25	35	36					
WBK15-01A	General	15	80	50	30	40	41	22	25	31	12	—
WBK15-01B	Low type			42	22	42	—					
WBK15-01C	Clean environment			50	30	40	41					
WBK17-01A	General	17	86	64	39	55	50	24	35	44	7	—
WBK20-01	General	20	95	58	30	45	56	30	42	52	10	—
WBK25-01W	General	25	105	68	35	25	66	36	48	61	13	—

- Notes:
1. Use datum surface A for mounting to machine base.
 2. Tighten set screw after locknut has been adjusted and tightened.
 3. Insert brass pad provided with unit into locknut set screw hole, then insert and tighten the set screw.
 4. Deep groove ball bearing and snap ring are also provided for simple support side.
(except WBK04-01M, WBK06-01M and WBK06-01A)

Support Unit (Support Units for Light Load and Small Equipment)

Reference No.	Tightening torque (reference) [N·cm]	
	Locknut	Set screw
WBK04-**	100	69 (M3)
WBK06-**	190	69 (M3)
WBK08-**	230	69 (M3)
WBK10-**	280	147 (M4)
WBK12-**	630	147 (M4)
WBK15-**	790	147 (M4)
WBK17-**	910	147 (M4)
WBK20-**	1670	147 (M4)
WBK25-**	2060	490 (M6)

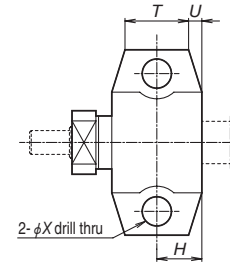

View S (WBK06 - 15)

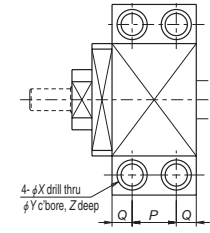
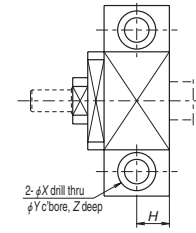

View S (WBK17 - 20)

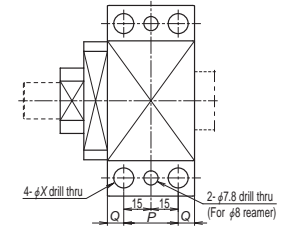

View S (WBK25)

Units: mm

T	U	N	Counterbore dimensions							Mass (kg)	Locknut screw M	Attached bearing for support side					
			H	P	Q	W	X	Y	Z								
9	2.5	2	7	—	—	21	3.5	—	—	0.03	M4x0.5	—					
12	2.5	2.5	8.5	—	—	26	5.5	—	—	0.05	M6x0.75	—					
—	—	3.5	10	—	—	30	5.5	9.5	11	0.15	M6x0.75	—					
—	—	4	11.5	—	—	38	6.6	11	12	0.25	M8x1	606ZZ					
		3.5	11									46	9	14	18	0.3	606ZZ
		4	11.5									38	6.6	11	12	0.25	606VV
—	—	6	12	—	—	52	9	14	11	0.5	M10x1	608ZZ					
												19	0.45	608ZZ			
												11	0.5	608VV			
—	—	6	12	—	—	52	9	14	11	0.5	M12x1	6000ZZ					
												19	0.4	6000ZZ			
												11	0.5	6000VV			
—	—	5	12.5	—	—	60	11	17	15	0.7	M15x1	6002ZZ					
												23	0.6	6002ZZ			
												15	0.7	6002VV			
—	—	7	—	19	8	68	9	14	11	1.3	M17x1	6203ZZ					
—	—	10	—	22	10	75	11	17	15	1.4	M20x1	6204ZZ					
—	—	14	—	30	9	85	11	—	—	1.9	M25x1.5	6205ZZ					

5. Bearings for WBK04-01M and WBK06-01M are equipped with non-contact metal shield.
- *1) For retaining cover side of WBK06-01A, WBK08-01A and WBK08-01C, there are no seals.
6. Contact NSK if the rotational speed is 50 min⁻¹ and below.

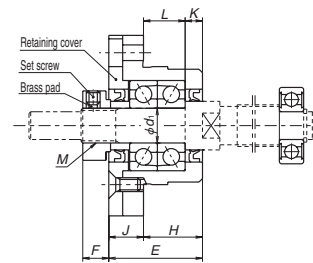
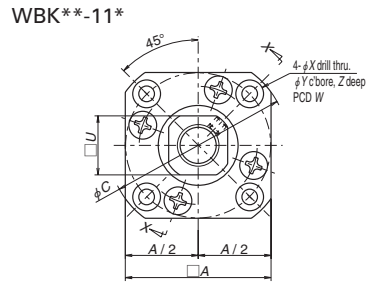
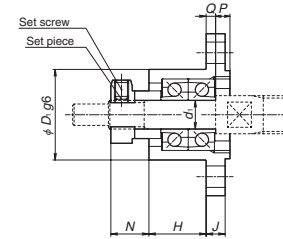
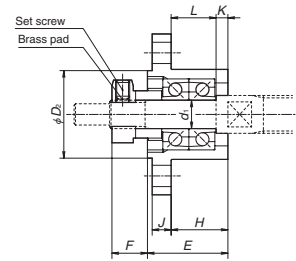
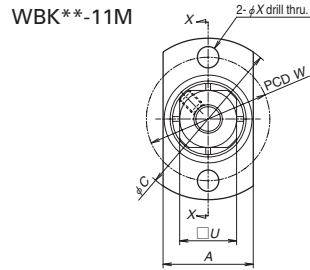

View X-X (example 1)

(example 2)

Reference No.	Tightening torque (reference) [N·cm]	
	Locknut	Set screw
WBK04-**	100	69 (M3)
WBK06-**	190	69 (M3)
WBK08-**	230	69 (M3)
WBK10-**	280	147 (M4)
WBK12-**	630	147 (M4)
WBK15-**	790	147 (M4)
WBK17-**	910	147 (M4)
WBK20-**	1670	147 (M4)
WBK25-**	2060	490 (M6)

Fixed support side support unit (round type)

Units: mm

Reference No.	Use	d_1	A	C	D_1	D_2	E	H	L	K	F	N
WBK04-11M	General	4	14	26	14	14	13.5	8.5	7	1.5	5.5	6.6
WBK06-11M	General	6	19	34	19	18.5	17	12	9.5	2.5	7.5	8
WBK06-11*	General	6	28	35	22	—	20	13	9.5	3.5	5.5	6.5
WBK08-11B	High-load type	8	42	52	34	—	25.5	15.5	12	3.5	4.5	7
WBK08-11*	General		35	43	28	—	23	14	10	4	7	8
WBK08-11C*	Clean environment		—	—	—	—	—	—	—	—	—	—
WBK10-11	General	10	42	52	34	—	27	17	12	5	7.5	8.5
WBK10-11C	Clean environment		—	—	—	—	—	—	—	—	—	—
WBK12-11	General	12	44	54	36	—	27	17	12	5	7.5	8.5
WBK12-11C	Clean environment		—	—	—	—	—	—	—	—	—	—
WBK15-11	General	15	52	63	40	—	32	17	11	6	12	14
WBK15-11C	Clean environment		—	—	—	—	—	—	—	—	—	—
WBK20-11	General	20	68	85	57	—	52	30	20	10	10	14
WBK25-11	General	25	79	98	63	—	57	30	20	10	13	20

U	P	Q	Counterbore dimensions					Mass (kg)	Locknut screw M	Attached bearing for support side
			J	W	X	Y	Z			
10	2.6	2.4	3	20	3.5	—	—	0.02	M4x0.5	—
12	3	2	4	26	4.5	—	—	0.04	M6x0.75	—
12	4.5	2.5	7	28	2.9	5.5	3.5	0.1	M6x0.75	—
14	6	4	10	42	4.5	8	4	0.2	M8x1	606ZZ
	5		9	35	3.4	6.5				606ZZ
17	6	4	10	42	4.5	8	4	0.2	M10x1	606VV
										608ZZ
19	6	4	10	44	4.5	8	4	0.25	M12x1	600ZZ
										6000VV
22	8	7	15	50	5.5	9.5	6	0.4	M15x1	6002ZZ
										6002VV
30	14	8	22	70	6.6	11	10	1.1	M20x1	6204ZZ
36	17	10	27	80	9	15	13	1.5	M25x1.5	6205ZZ

- Notes:
1. Tighten set screw after locknut has been adjusted and tightened.
 2. Insert brass pad provided with unit into locknut set screw hole, then insert and tighten the set screw.
 3. Deep groove ball bearing and snap ring are also provided for simple support side. (except WBK04-11M, WBK06-11M and WBK06-11)

4. Bearings for WBK04-11M and WBK06-11M are equipped with non-contact metal shield.
- *For retaining cover side of WBK06-11, WBK08-11 and WBK08-11C, there are no seals.
5. Contact NSK if the rotational speed is 50 min⁻¹ and below.

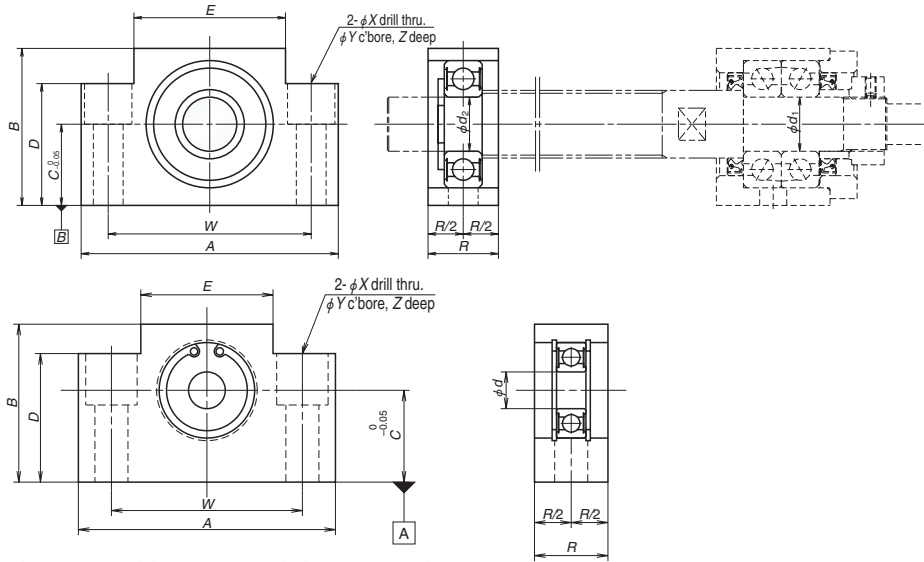

Simple support side support unit (square type)

Units: mm

Reference No.	Use	d ₂	A	B	C	D	E	R	Counterbore dimensions				Mass (kg)
									W	X	Y	Z	
WBK08S-01	General	6	52	32	17	26	25	15	38	6.6	11	12	0.15
WBK08S-01B	Low type		62	31	15.5	31	—	16	46	9	14	18	0.2
WBK08S-01C	Clean environment		52	32	17	26	25	15	38	6.6	11	12	0.15
WBK10S-01	General	8	70	43	25	35	36	20	52	9	14	11	0.4
WBK10S-01C	Clean environment		70	43	25	35	36	20	52	9	14	11	0.4
WBK12S-01	General	10	70	43	25	35	36	20	52	9	14	11	0.35
WBK12S-01B	Low type			38	20	38	—					19	0.4
WBK12S-01C	Clean environment			43	25	35	36					11	0.35
WBK12SF-01^{*2}	General	12	62	31	15.5	31	—	18	46	9	14	11	0.3
WBK12SF-01B^{*1}	Low type											18	0.2
WBK15S-01	General	15	80	50	30	40	41	20	60	9	14	11	0.45
WBK15S-01B	Low type			42	22	42	—					23	0.4
WBK15S-01C	Clean environment			50	30	40	41					11	0.45
WBK15SF-01^{*2}	General			43	25	35	36					11	0.3
WBK15SF-01B^{*1}	Low type	70	38	20	38	—	18	52	11	17	15	0.55	
WBK17S-01	General	17	86	64	39	55	50	23	68	9	14	11	0.8
WBK20S-01	General	20	95	58	30	45	56	26	75	11	17	15	0.8
WBK20SF-01B	Low type		80	42	22	42	—	22	60			23	0.4
WBK25S-01W	General	25	105	68	35	25	66	30	85	11	—	—	0.9
WBK25SF-01^{*1}			95	58	30	45	56	22	75	11	17	15	0.55

- Notes:
1. Use datum surface B for mounting to machine base.
 2. For reference No. 12 or lower numbers, note that the reference numbers and inner dimensions of the bearing are different.
 3. WBK ** SF is a type supporting screw shaft OD.
 4. See page B400 for bearing reference number and the basic dynamic load rating in the radial direction.
 5. *1 is exclusive for FSS type.
 6. *2 is exclusive for VFA type.

Specifications of support unit

Reference No.	Use	Fixed support side support unit				Simple support side support unit		
		Basic dynamic load rating Ca [N]	Load limit [N]	Rigidity [N/μm]	Maximum starting torque [N-cm]	Reference No.	Bearing reference No.	Radial direction Basic dynamic load rating C [N]
WBK04-01M	General	1 470	464	39	0.2	—	—	—
WBK04-11M	General	1 470	464	39	0.2	—	—	—
WBK06-01A	General	2 670	1 040	28	0.49	—	—	—
WBK06-01M	General	2 760	854	60	0.35	—	—	—
WBK06-11	General	2 670	1 040	28	0.49	—	—	—
WBK06-11M	General	2 760	854	60	0.35	—	—	—
WBK08-01A	General	4 400	1 450	49	0.88	WBK08S-01	606ZZ	2 260
WBK08-01B	Low type	6 600	2 730	94	1.9	WBK08S-01B	606ZZ	2 260
						WBK12SF-01B^{*1}	6801ZZ	1 920
WBK08-01C	Clean environment	3 100	1 100	36	0.52	WBK08S-01C	606VV	2 260
WBK08-11	General	4 400	1 450	49	0.88	WBK08S-01	606ZZ	2 260
WBK08-11B	High load	6 600	2 730	94	1.9	—	606ZZ	2 260
WBK08-11C	Clean environment	3 100	1 100	36	0.52	WBK08S-01C	606VV	2 260
WBK10-01A	General	6 600	2 730	94	1.9	WBK10S-01	608ZZ	3 300
						WBK12SF-01^{*2}	6001ZZ	5 100
WBK10-01B	Low type	6 600	2 730	94	1.9	—	608ZZ	3 300
WBK10-01C	Clean environment	4 250	1 364	50	1.1	WBK10S-01C	608VV	3 300
WBK10-11	General	6 600	2 730	94	1.9	WBK10S-01	608ZZ	3 300
WBK10-11C	Clean environment	4 250	1 364	50	1.1	WBK10S-01C	608VV	3 300
WBK12-01A	General	7 100	3 040	104	2.1	WBK12S-01	6000ZZ	4 550
						WBK15SF-01^{*2}	6902ZZ	4 350
WBK12-01B	Low type	7 100	3 040	104	2.1	WBK12S-01B	6000ZZ	4 550
						WBK15SF-01B^{*1}	6902ZZ	4 350
WBK12-01C	Clean environment	4 700	2 443	57	1.2	WBK12S-01C	6000VV	4 550
WBK12-11	General	7 100	3 040	104	2.1	WBK12S-01	6000ZZ	4 550
WBK12-11C	Clean environment	4 700	2 443	57	1.2	WBK12S-01C	6000VV	4 550
WBK15-01A	General	7 600	3 380	113	2.4	WBK15S-01	6002ZZ	5 600
WBK15-01B	Low type	7 600	3 380	113	2.4	WBK15S-01B	6002ZZ	5 600
						WBK20SF-01B^{*1}	6804ZZ	4 000
WBK15-01C	Clean environment	5 100	2 757	63	1.3	WBK15S-01C	6002VV	5 600
WBK15-11	General	7 600	3 380	113	2.4	WBK15S-01	6002ZZ	5 600
WBK15-11C	Clean environment	5 100	2 757	63	1.3	WBK15S-01C	6002VV	5 600
WBK17-01A	General	13 400	5 800	120	3.5	WBK17S-01	6203ZZ	9 550
WBK20-01	General	17 900	8 240	155	6.2	WBK20S-01	6204ZZ	12 800
						WBK25SF-01^{*1}	6005ZZ	10 100
WBK20-11	General	17 900	8 240	155	6.2	WBK20S-01	6204ZZ	12 800
WBK25-01W	General	20 200	10 000	192	7.2	WBK25S-01W	6205ZZ	14 000
WBK25-11	General	20 200	10 000	192	7.2	WBK25S-01W	6205ZZ	14 000
WBK04R-11	General	615	490	6.5	0.59	—	—	—
WBK06R-11	General	1 280	930	9	0.59	—	—	—

- Notes:
1. *1 is exclusive for FSS type.
 2. *2 is exclusive for VFA type.
 3. Permissible axial load is 0.7 times of limiting axial load.

Support kits for ball screws for transfer equipment

Support kits are for RMA type ball screw.

In case of RMA1002 or larger rolled ball screws, please use support units for general use.

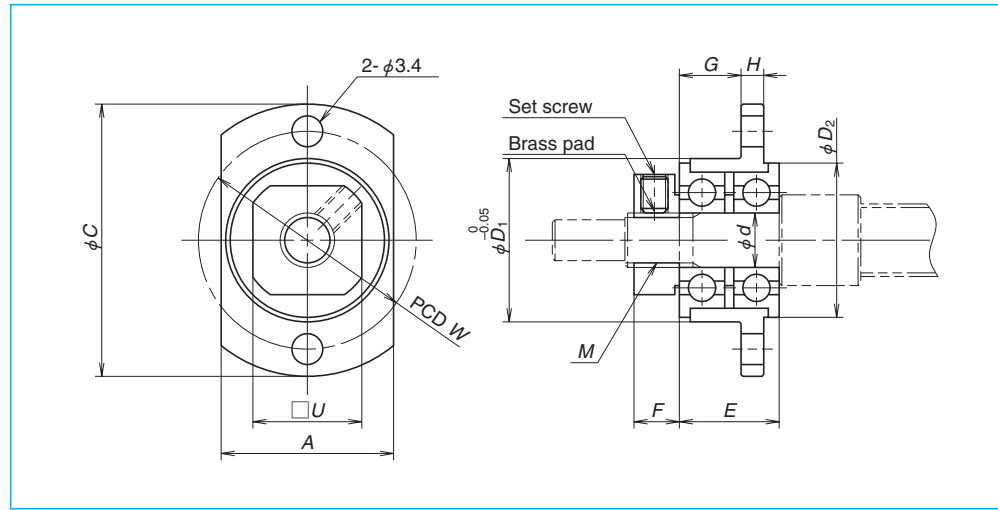

Units: mm

Reference No.	A	C	d	D ₁	D ₂	E	F	G	H	W	U	M	Mass (kg)
WBK04R-11	14	25	4	13	12.5	9	5	5	2.5	19	10	M4×0.5	0.13
WBK06R-11	19	30	6	18	17	11	5	6.8	2.5	24	12	M6×0.75	0.23

Reference No.	Applicable ball screw	Locknut tightening torque (reference) [N·cm]	Set screw tightening torque (reference) [N·cm]
WBK04R-11	RMA0601	100	38 (M2.5)
WBK06R-11	RMA0801 RMA0801.5 RMA0802	190	69 (M3)

Notes:

- Oscillate bearings slowly so that they fall into place in which run-out of mounting surface is minimal, and then tighten locknut.
- Support kit is on provisional shaft (bolt) during shipping.
- When securing support unit on shaft, insert brass pad that is provided with support unit into lock nut hole, and then tighten set screw.

Spacer

When using a fixed support unit, it may require an optional spacer to have an effective shoulder surface at where the ball thread is threaded to the end of the shoulder. This is common for the R series for transporting ball screws.

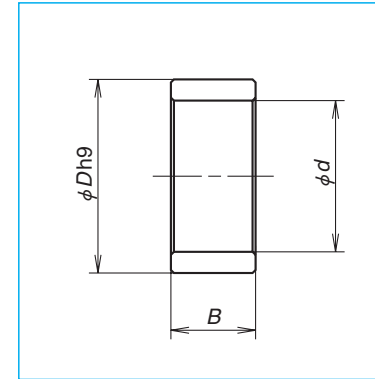

Units: mm

Reference No.	Internal diameter, d	Outside diameter, D	Width B	Mass (g)	Applicable support unit
WBK06K	6	9.5	5.0	2	WBK06- **
WBK08K	8	11.5	5.5	2	WBK08- **
WBK10K	10	14.5	5.5	4	WBK10- **
WBK12K	12	15.0	5.6	3	WBK12- **
WBK15K	15	19.5	10.0	10	WBK15- **
WBK17K	17	24.4	7.0	13	WBK17- **
WBK20K	20	25.5	11.0	17	WBK20- **
WBK25K	25	32.0	14.0	34	WBK25- **

Screw shaft end configuration

Dimensions of the shaft end configurations for light load and small equipment support units are shown in the table below. When using a spacer

with a ball screw for transporting equipment, add the width of the spacer (B from the table of spacer dimensions on page B402) to L_1 dimension below.

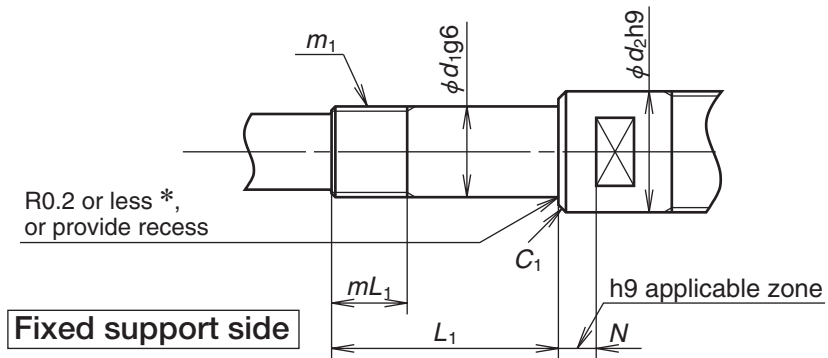

Radius marked with * above is 0.15 or less for WBK04R-11 and WBK06R-11.

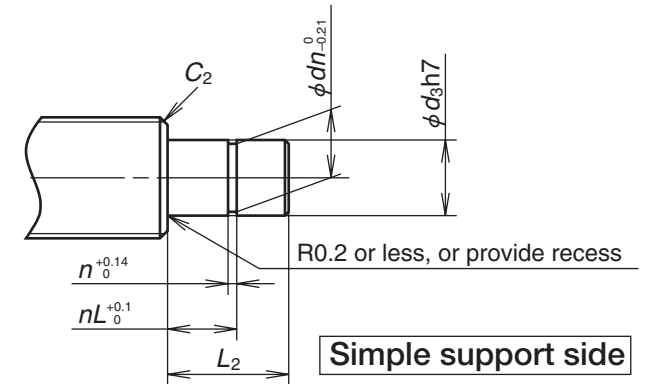

Units: mm

Reference No.	Fixed support side						
	Bearing journal		Locknut thread		Sealing part		Chamfer
	d_1	L_1	m_1	mL_1	d_2	N	C_1
WBK06- **	6	22.5	M6x0.75	7	9.5	3.5	0.2
WBK08- **	8	27	M8x1	9	11.5	4	0.2
WBK10- **	10	30	M10x1	10	14	6	0.2
WBK12- **	12	30	M12x1	10	15	6	0.2
WBK15- **	15	40	M15x1	15	19.5	5	0.3
WBK17- **	17	46	M17x1	17	24	7	0.3
WBK20- **	20	53	M20x1	16	25	10	0.3
WBK25- **	25	62	M25x1.5	20	32	14	0.5
WBK04R-11	4	15	M4x0.5	7.5	—	—	0.3
WBK06R-11	6	17	M6x0.75	7.5	—	—	0.3

Units: mm

Reference No.	Simple support side					
	Bearing journal		Snap ring groove			Chamfer
	d_3	L_2	n	dn	nL	C_2
—	—	—	—	—	—	—
WBK08S- **	6	9	0.8	5.7	6.8	0.2
WBK10S- **	8	10	0.9	7.6	7.9	0.2
WBK12S- **	10	22	1.15	9.6	9.15	0.5
WBK15S- **	15	25	1.15	14.3	10.15	0.5
WBK17S- **	17	16	1.15	16.2	13.15	0.5
WBK20S- **	20	19	1.35	19	15.35	0.5
WBK25S- **	25	20	1.35	23.9	16.35	0.5

(2) Support unit for ball screws for high-speed and heavy-load machine tools

Support units for high-speed and heavy-load machine tools use the ball screw support bearings NSKHPS™ BSBD series. This series has very suitable functions and structure as a ball screw support bearing. There are three bearing combinations as shown below.

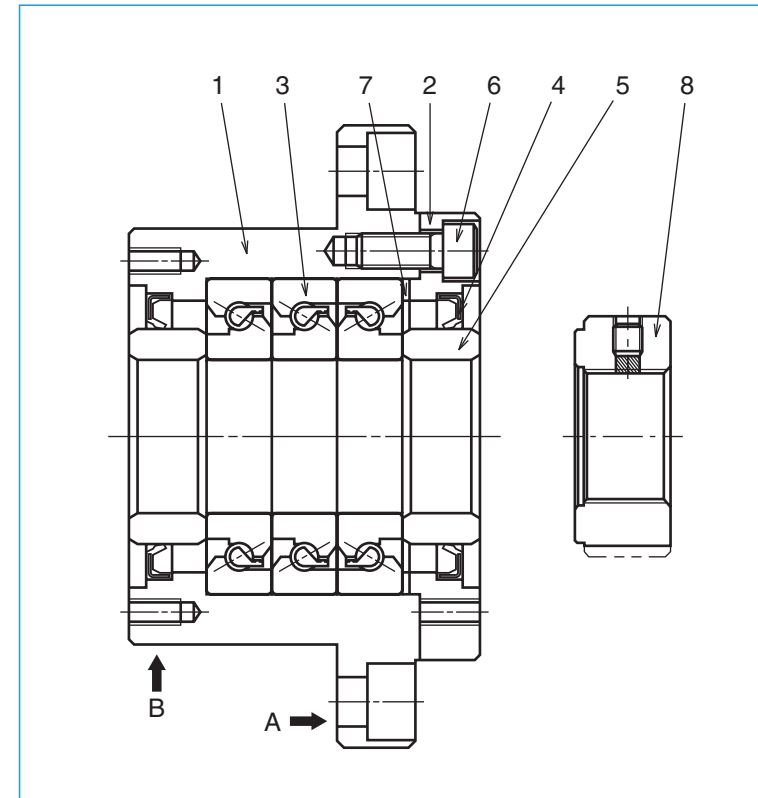
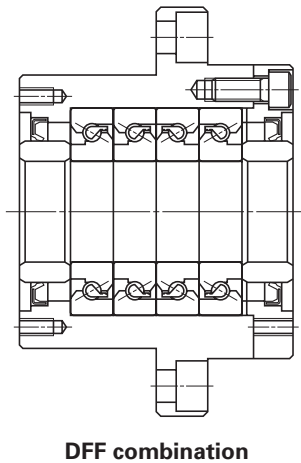
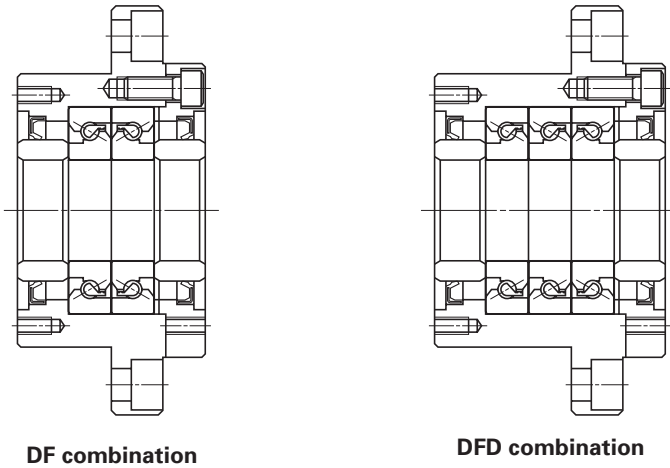

Parts list

Part No.	Part name	Quantity
1	Housing	1
2	Retaining cover	1
3	High accuracy thrust angular contact ball bearing	One set
4	Dust seal	2
5	Collar	2
6	Preload bolt	6 or 8
7	Shim	One set
8	Lock nut	1

Notes:

- Surface A and B are the datum surfaces to mount a support unit to machine housing.
- NSK support units are precisely preloaded and adjusted. Do not disassemble the components 1, 2, 3, 4, 5, 6 and 7.
- Grease is packed into the bearings.
- Lock nut 8 is exclusively prepared for ball screws. End surface of nut is in strict control being precisely perpendicular to the V thread. Secure lock nut using set screw. Lock nut is also available as accessory. (See page B409.)
- See page B415 as well for NSK TAC C Series angular contact thrust ball bearings for ball screw support.

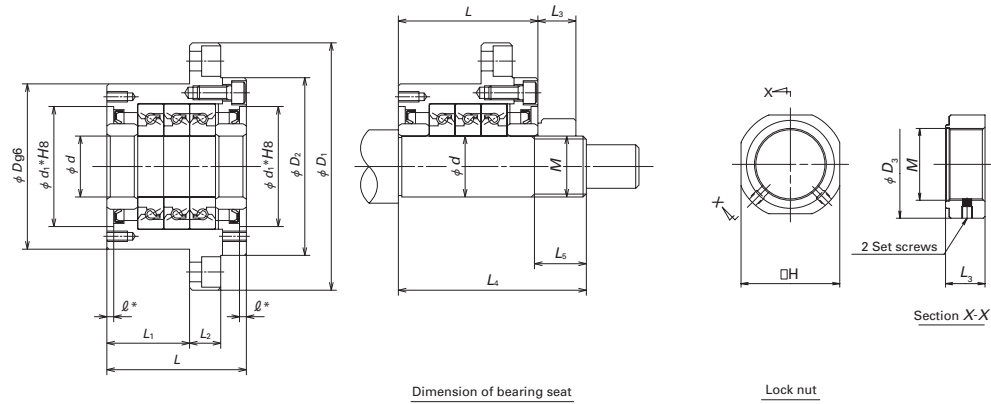

Dimension of bearing seat

Lock nut

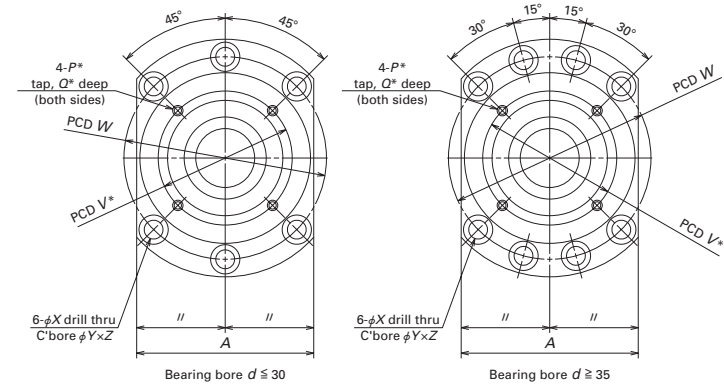

Bearing bore $d \leq 30$

Bearing bore $d \geq 35$

Unit: mm

Support unit No.	Support unit																Basic dynamic load rating C_0 [N]	Limiting axial load [N]	
	d	D	D_1	D_2	L	L_1	L_2	A	W	X	Y	Z	d_1^*	ϕ^*	V^*	P^*			Q^*
WBK17DF-31H	17	70	106	72	60	32	15	80	88	9	14	8.5	45	3	58	M5	10	23 000	26 600
WBK20DF-31H	20	70	106	72	60	32	15	80	88	9	14	8.5	45	3	58	M5	10	23 000	26 600
WBK25DF-31H	25	85	130	90	66	33	18	100	110	11	17.5	11	57	4	70	M6	12	29 900	40 500
WBK25DFD-31H					81	48												48 500 (29 900)	81 500 (40 500)
WBK30DF-31H	30	85	130	90	66	33	18	100	110	11	17.5	11	57	4	70	M6	12	30 500	43 000
WBK30DFD-31H					81	48												50 000 (30 500)	86 000 (43 000)
WBK35DF-31H	35	95	142	102	66	33	18	106	121	11	17.5	11	69	4	80	M6	12	32 500	50 000
WBK35DFD-31H					81	48												53 000 (32 500)	100 000 (50 000)
WBK35DFF-31H					96	48												53 000	100 000
WBK40DF-31H	40	95	142	102	66	33	18	106	121	11	17.5	11	69	4	80	M6	12	33 500	52 000
WBK40DFD-31H					81	48												54 000 (33 500)	104 000 (52 000)
WBK40DFF-31H					96	48												54 000	104 000

- Notes: 1. Rigidity
Values in the table are theoretical values obtained from the elastic deformation between ball groove and balls.
2. Starting torque
Starting torque indicates torque due to the preload of the bearing. It does not include seal torque.
3. The tolerance of the shaft bearing seat
We recommend h5 class of the fits tolerance.
4. Values in parentheses of basic dynamic load rating and permissible axial load are the values when axial load is applied in a line.

Preload C_0 [N]	Axial rigidity [N/ μ m]	Starting torque [N · cm]	Lock nut						Bearing seat for unit			Permissible rotational speed [min^{-1}]	Mass [kg]
			Dimension				Screwing torque (reference) [N · cm]	d	L_4	L_5			
			M	H	D_3	L_3							
1 450	630	14	M17×1.0	32	37	18	4 100	17	81	23	6 900	1.9	
1 450	630	14	M20×1.0	36	40	18	4 500	20	81	23	6 900	1.9	
2 280	850	21	M25×1.5	41	45	20	8 500	25	89	26	5 200	3.1	
3 100	1 250	28						104	26	5 200	3.4		
2 400	890	23	M30×1.5	46	50	20	10 100	30	89	26	4 900	3.0	
3 260	1 310	30						104	26	4 900	3.3		
2 750	1 030	27	M35×1.5	50	55	22	13 800	35	92	30	4 100	3.4	
3 740	1 500	34						107	30	4 100	4.3		
5 490	2 060	43						122	30	4 100	5.0		
2 860	1 080	28	M40×1.5	55	60	22	15 500	40	92	30	4 100	3.6	
3 900	1 590	36						107	30	4 100	4.2		
5 730	2 150	46						122	30	4 100	4.7		

5. Dimensions with * (asterisk) mark
*Pilot diameter and tapped screws marked with asterisk are used for seal unit installation for NSK standard hollow shaft ball screws. They also can be used for dust cover and damper installation.
6. Grease is packed into bearing. It is not necessary to apply grease before use.
7. Permissible axial load is 0.7 times of limiting axial load.
8. Contact NSK if the rotational speed is 50 min^{-1} and below.

In addition to the support units, NSK has other components for ball screws as shown below.

(3) Lock nuts

Ball screw support bearings must be installed

with minimum inclination against ball screw center. NSK lock nuts exclusive for ball screw support bearings help to reduce this inclination.

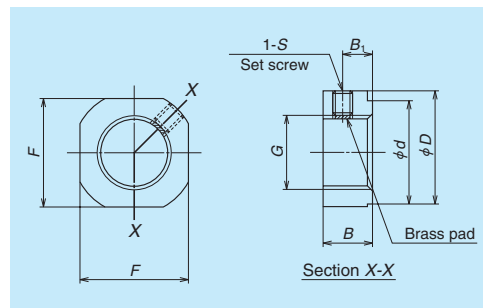

Light load Shapes and dimensions

Light load lock nuts

Light load lock nuts

Lock nut reference No.	G	D	F	B	d
WBK04L-01	M4×0.5	11.5	10	5	6
WBK06L-01	M6×0.75	14.5	12	5	10
WBK08L-01	M8×1	17	14	6.5	13
WBK10L-01	M10×1	20	17	8	16
WBK12L-01	M12×1	22	19	8	17
WBK15L-01	M15×1	25	22	10	21
WBK17L-01	M17×1	29	24	13	24
WBK20L-01	M20×1	35	30	13	26
WBK25L-01	M25×1.5	42	36	16	34

Note: Insert brass pad and then tighten securing set screw.

High speed and heavy load lock nuts

Lock nut reference No.	G	D _{0.1}	B	d ₁	d ₂
WBK17L-31H	M17×1	37	18	30	18
WBK20L-31H	M20×1	40	18	30	21
WBK25L-31H	M25×1.5	45	20	40	26
WBK30L-31H	M30×1.5	50	20	40	31
WBK35L-31H	M35×1.5	55	22	49	36
WBK40L-31H	M40×1.5	60	22	49	41

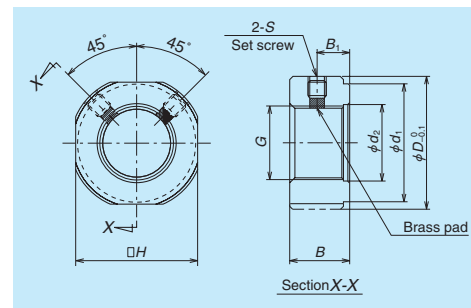

High speed and heavy load Shapes and dimensions

High speed and heavy load lock nuts

B ₁	S	Tightening torque (reference) [N · cm]	Set screw tightening torque (reference) [N · cm]	Mass (g)
2.75	M3, with a brass pad	100	69 (M2.5)	3.0
2.75	M3, with a brass pad	190	69 (M3)	3.8
4	M3, with a brass pad	230	69 (M3)	6.4
5	M4, with a brass pad	280	147 (M4)	11.2
5	M4, with a brass pad	630	147 (M4)	12.8
6	M4, with a brass pad	790	147 (M4)	20.0
8	M4, with a brass pad	910	147 (M4)	33.1
8	M4, with a brass pad	1 670	147 (M4)	50.0
10	M6, with a brass pad	2 060	490 (M6)	87.0

Unit: mm

B ₁	H	S	Tightening torque (reference) [N · cm]	Set screw tightening torque (reference) [N · cm]	Mass (g)
10	32	M6	4 100	490 (M6)	100.9
10	36	M6	4 500	490 (M6)	117.3
11	41	M6	8 500	490 (M6)	163.8
11	46	M6	10 100	490 (M6)	186.7
12	50	M6	13 800	490 (M6)	233.4
12	55	M6	15 500	490 (M6)	258.8

Unit: mm

Installation of Ball Screw and Support Unit

The illustrations below show typical installation procedures for a standard ball screw and a support unit.

1) Assembly of support unit

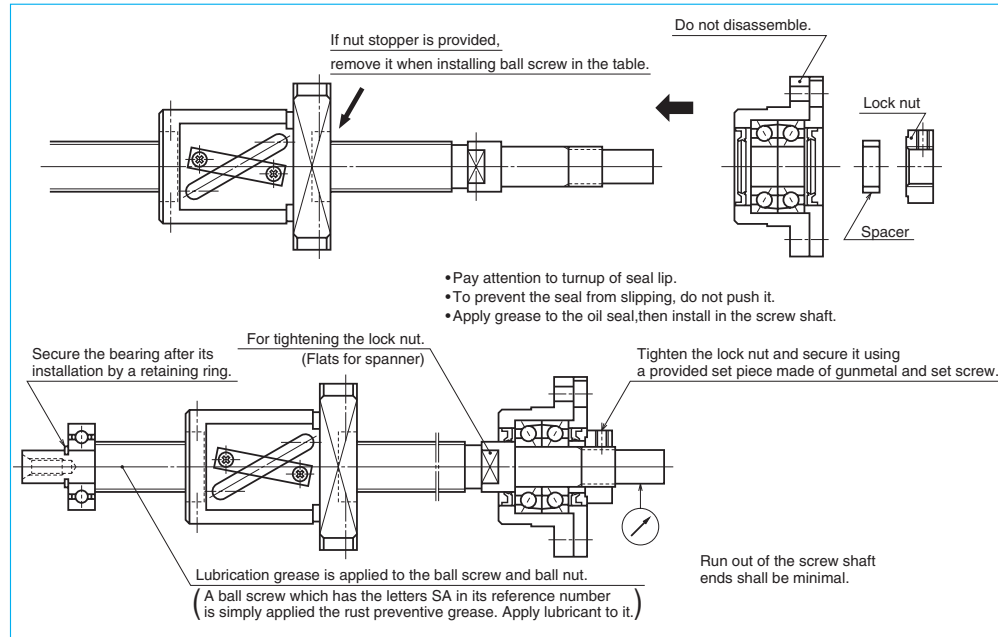

2) Installation of ball nut to the table

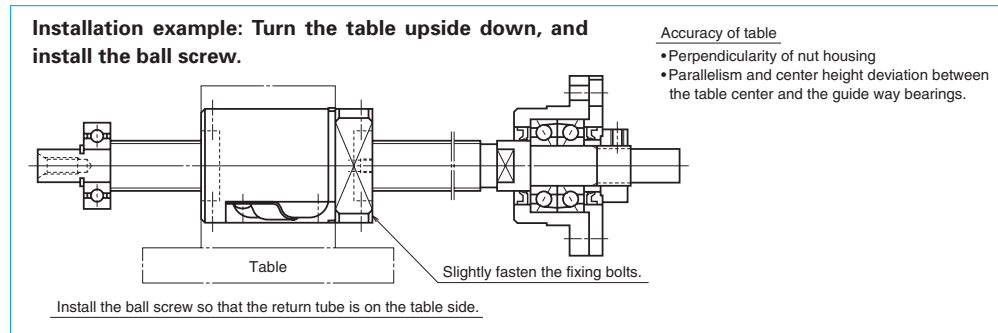

3) Base and the support unit installation on the fixed support side

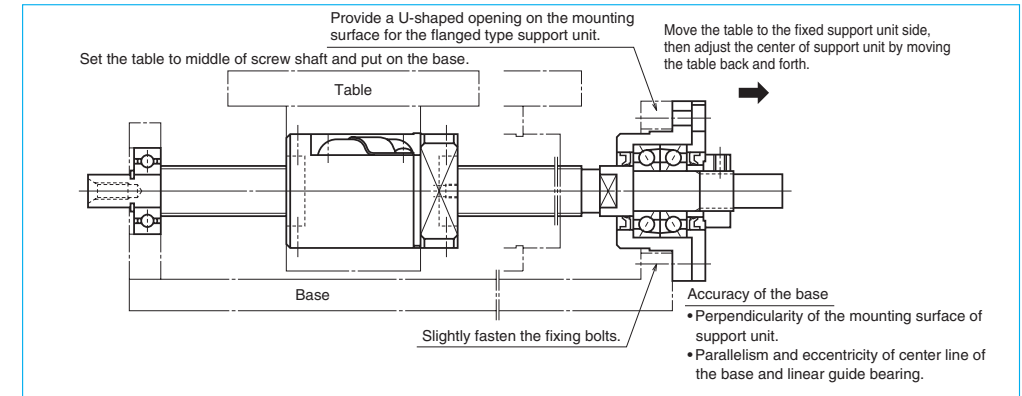

4) Base and bearing installation on simple support side, and confirming assembling accuracy.

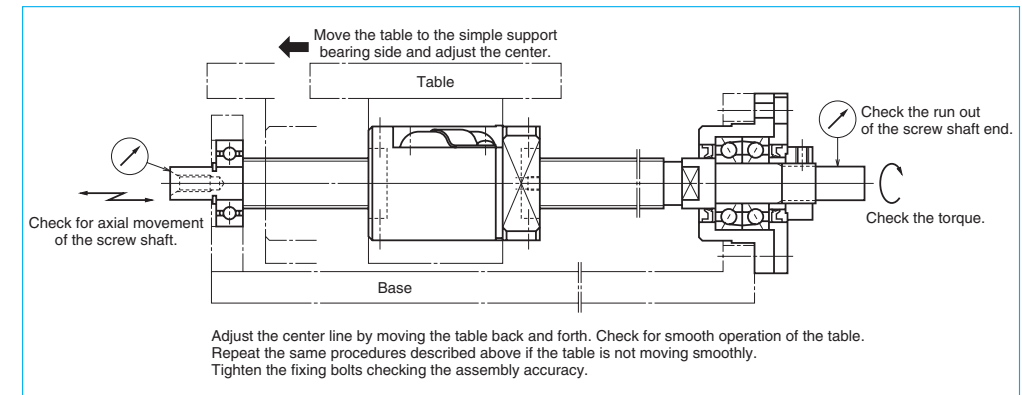

5) Assembly completed.

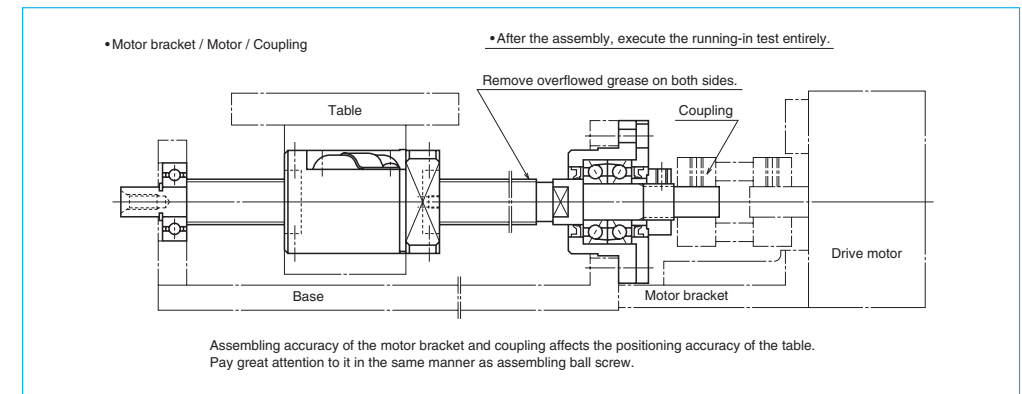

(4) Grease unit

NSK has numerous grease types that are exclusive for ball screw lubrication. They come in bellows-shaped tubes, which can be attached

to a hand grease pump quickly. For details of grease types, see page D13 and for a hand grease pump and nozzles, see page D19.



NSK greases

Lubricant greases

Name	Use	Base oil viscosity mm ² /s (40°C)
NSK Grease AS2	For heavy load	130
NSK Grease PS2	High-speed, light load	15
NSK Grease LR3	High-speed, medium load	30
NSK Grease LG2	Clean environment	30
NSK Grease LGU	Clean environment	100

(5) Travel stopper (made-to-order)

A travel stopper is installed in some cases to prevent the ball nut from overrunning to the end of ball thread due to a malfunction of the safety system of the equipment or by a human error. NSK has several series of shock-absorbing travel stoppers. The travel stopper is not sold as a single item since it is not for general use.

Also, a travel stopper cannot be used for ball screw with the end cap type ball recirculation system, because the stopper would come directly into contact with the component for ball recirculation. Please request NSK for the installation of the travel stoppers when ordering a ball screw.

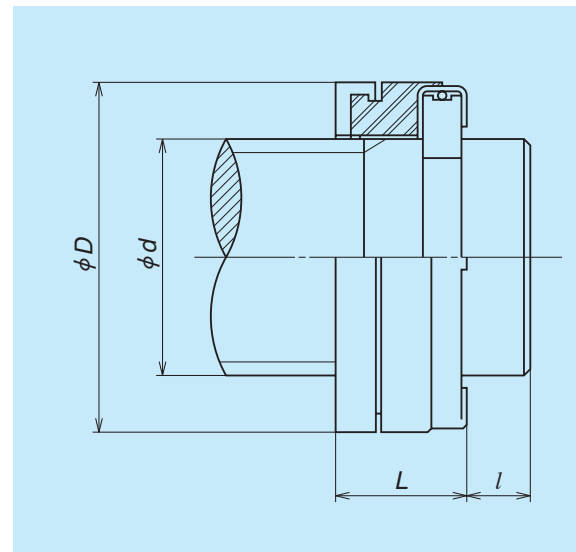

Stopper No.	Applicable shaft dia.	Outer dia.	Length	Shaft end width (Min.)
	<i>d</i>	<i>D</i>	<i>L</i>	<i>l</i>
BSR 20	20	32	16	5
BSR 25	25	38	16	5
BSR 32	32	46	20	6
BSR 40	40	60	22	6
BSR 50	50	72	24	7
BSR 63	63	85	25	7

Note: This stopper is patented by NSK Ltd.

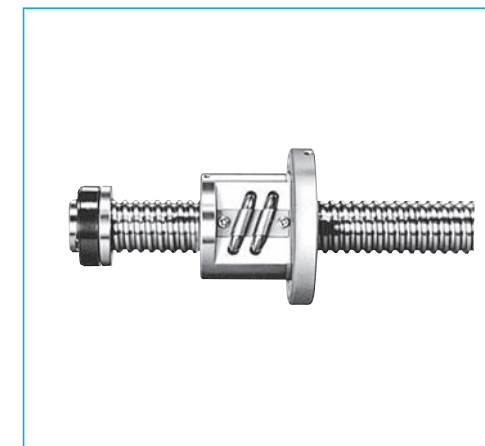

Shock-absorbing travel stopper

(6) NSKHPS angular contact thrust ball bearings for ball screw support

1. Features

This is highly rigid and accurate ball screw support bearing often used for the machine tools driving mechanism.

NSKHPS:Reliability has been improved by focusing on material cleanliness, which has the biggest impact on bearing life, by employing NSK's proprietary material evaluation technology. The dynamic load rating has been improved by 5% compared with that of conventional bearings.

The NSKTAC C Series features high axial rigidity and is suitable for machine tool feeding mechanisms, while the NSKTAC 03 Series with its high axial load capacity is well suited for the support of large ball screws in high-load drive applications such as electric injection molding machines. With these series users can achieve much lower torque and higher accuracy than with roller bearings.

(a) High axial rigidity

The axial rigidity is high because of a higher contact angle of 60°

(b) Low starting torque

Compared with tapered roller bearings or cylindrical roller bearings, this type has lower starting torque; so smoother rotation is possible with driving force.

(c) Easy Installation

The clearance in each individual bearing in a combination is adjusted to obtain the optimum preload. With universal combination bearings (combination symbol SU), a specific preload is obtained when used with others having the same bearing number in any combination (DB, DF, and others).

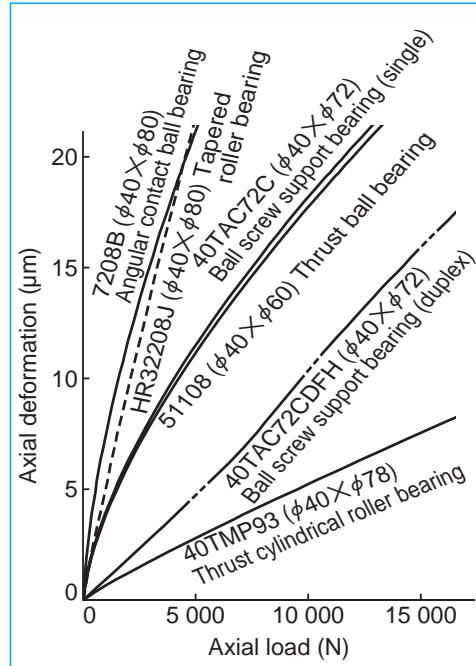

Fig. 1 Axial rigidity of various bearings

(d) Structural simplicity

Since this type can sustain both axial and radial loads, the surrounding structure is simpler and more compact than when using a combination of radial and thrust bearings.

(e) Easy handling

Since the Inner and outer rings are inseparable, handling is easy.

Table 2 Comparison with other types of bearings

Bearing type	Bearing rigidity (See Fig. 1)	Starting torque	Preload adjustment	Installation structure
Ball screw support bearings	High	Low	Not required	Simple
Combined angular contact ball bearing	Low	Low	Not required	Simple
Tapered roller bearing	Low	High	Complicated	Simple
Thrust ball bearing and radial bearing	High	Low	Complicated	Complicated
Thrust cylindrical roller bearing and radial bearing	Extremely high	Extremely high	Complicated	Complicated

Note: Consult NSK when you use these bearings other than the purpose of ball screw support.

2. Bearing combinations

Angular contact thrust ball bearings for ball screw support are generally used in two or more rows with preload applied.

Universal Combination Bearings

NSK manufactures universal combination bearings which have been controlled to have the same amount of stand-out (offset) on their front and back faces. That way, for bearings with the same bearing number, users will achieve the specified amount for each standard preload, regardless of which combination they chose. Each universal combination bearing comes with a V-shaped mark on the surface of the outer ring to simplify identification of the correct direction when mounting and to ensure that the correct combination is achieved. The V-shaped mark points to the direction of the axial load that the inner ring supports (contact angle).

Combination Mark and Matching Method for Universal Combination Bearings

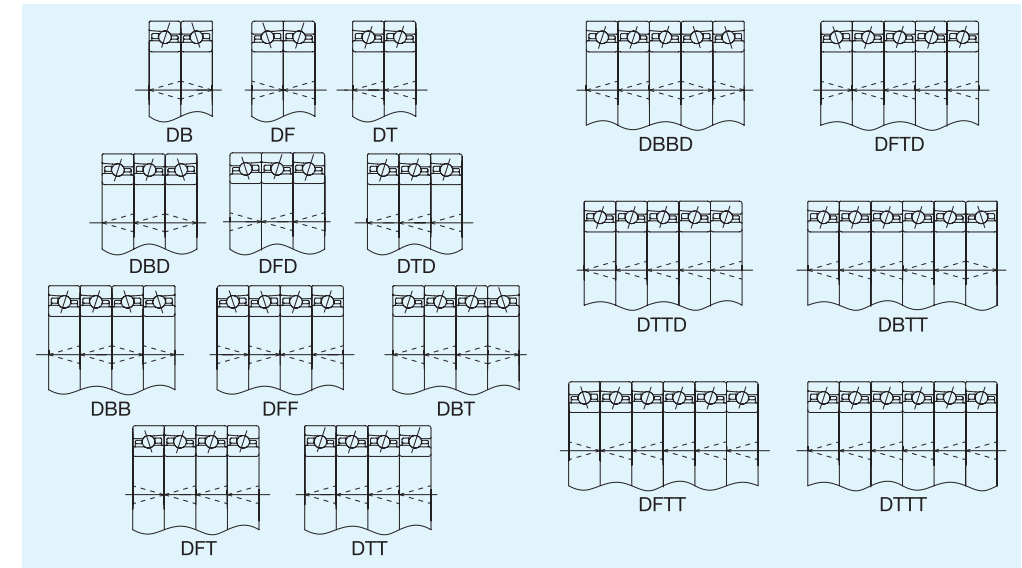

3. Permissible Axial Load for Angular Contact Ball Bearings

NSK has defined the limiting static axial load as the smaller of the two values listed below:

(1) Limiting axial load that produces shoulder override
The limiting load at which the contact ellipse generated between the ball and the raceway overrides the shoulder of the raceway groove (Fig. 2)

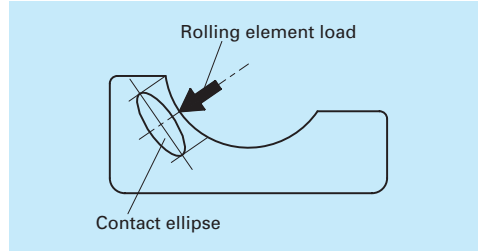

Fig. 2 Ride-over limit axial load

(2) Limiting axial load in terms of surface pressure
The limiting load at which the contact stress at the center of the contact area between the ball and the raceway groove reaches a level that leaves an indentation as defined in the basic static load rating (Fig. 3)

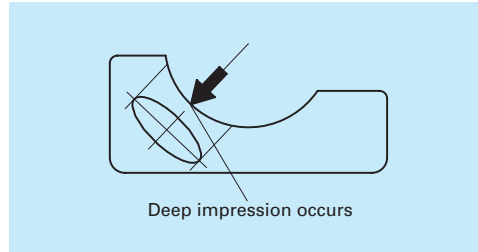

Fig. 3 Contact pressure limit axial load

To maintain optimal bearing performance, NSK has defined permissible static axial load values by applying a safety factor to the limiting axial load based on many years of experience. The formula for calculating the basic static axial load rating C_{0a} does not take the shoulder height of the raceway groove into account. Therefore, in some cases the C_{0a} value may exceed the limiting axial load that produces shoulder override.

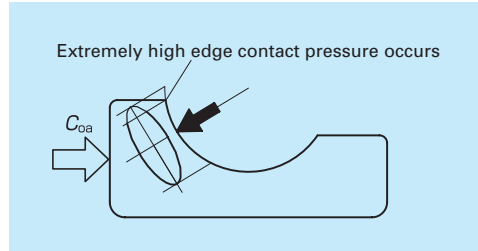

Fig. 4 C_{0a} and limit axial load

In such cases, the maximum load that the bearing can sustain is lower than the C_{0a} value, making the C_{0a} value unsuitable (Fig. 4). Therefore, instead of C_{0a} values, we have listed limiting axial load values in the bearing tables where necessary, particularly for angular contact thrust ball bearings as they are usually used to support heavy axial loads.

4. Rolling contact fatigue life

The relationship between basic load rating, bearing load, and basic rating life for the rolling bearing is presented in the following formula.

$$L_h = \frac{10^6}{60n} \left(\frac{C_0}{P} \right)^3$$

Where, L_h : Basic rating life (h)

C_0 : Basic dynamic load rating (N)

P : Dynamic equivalent load (N)

n : Rotational speed (min^{-1})

See the right table for dynamic equivalent load in each combination.

Dynamic equivalent load $P_a = XF_r + YF_a$

Bearing configuration Combination code Number of the row (for raceway axial load)	Duplex		Triplex			Quadruplet			
	DF	DT	DFD	DTD	DFT	DFD	DFT		
$e = 2.17$	One row	Two rows	One row	Two rows	Three rows	One row	Two rows		
$F_a/F_r \leq e$	X	1.9	-	1.43	2.33	-	1.17	1.9	2.53
	Y	0.55	-	0.77	0.35	-	0.89	0.55	0.26
$F_a/F_r > e$	X	0.92	0.92	0.92	0.92	0.92	0.92	0.92	0.92
	Y	1	1	1	1	1	1	1	1

5. Fits

Recommended interference values for standard operating conditions of ball screws are listed in Tables 3. When using angular contact thrust ball bearings for high-load drive ball screw support, in cases where a single end is supported and moment loads are high, it is advisable to increase shaft interference, for example by choosing k5 etc. as required.

Table 3 Tolerances for Shaft and Housing Bore Diameters Unit: μm

Shaft Outer Diameter, Housing Bore Diameter (mm)	Tolerance of shaft outer diameter						Tolerance of housing bore diameter		
	Angular contact thrust ball bearings for high-rigidity applications		Angular contact thrust ball bearings for high-load drive applications		Angular contact thrust ball bearings for high-load drive applications				
	Over	Incl.	Min.	Max.	Min.	Max.	Min.	Max.	
10	18	-8	0	-4	4	-	-	-	-
18	30	-9	0	-4.5	4.5	-	-	-	-
30	50	-10	0	-5.5	5.5	0	16	-	-
50	80	-13	0	-6.5	6.5	0	19	-	-
80	120	-	-	-7.5	7.5	0	22	-	-
120	180	-	-	-9.0	9.0	0	25	-	-
180	250	-	-	-	-	0	29	-	-
250	315	-	-	-	-	0	32	-	-
315	400	-	-	-	-	0	36	-	-

6. Bearing Accuracy

Table 4 to 6 shows accuracy for angular contact thrust ball bearings for ball screw support.

Table 4 Tolerances for angular contact thrust ball bearings NSKTAC C for high-rigidity ball screw support (Class PN7C ⁽¹⁾) Unit: μm

Nominal Bore (or outer diameter) (mm)		Single Plane Mean Bore Diameter Deviation ΔDmp		Deviation of Single Bore Diameter ΔDs		Single Plane Mean Outside Diameter Deviation ΔDmp		Deviation of Single Outside Diameter ΔDs		Deviation of Single Inner Ring Width ΔBs		Inner ring (Outer Ring) Face Runout with Raceway Sia (Seal)	
Over	Incl.	High	Low	High	Low	High	Low	High	Low	High	Low	Max.	
10	18	0	-4	0	-4	-	-	-	-	0	-	-120	2.5
18	30	0	-5	0	-5	-	-	-	-	0	-	-120	2.5
30	50	0	-6	0	-6	0	-6	0	-6	0	-	-120	2.5
50	80	0	-7	0	-7	0	-7	0	-7	0	-	-150	2.5
80	120	-	-	-	-	0	-8	0	-8	-	-	-	2.5

Note: 1. NSK specification

Table 5 Tolerances for angular contact thrust ball bearings NSKTAC 03 for high-load drive applications ball screw support (Class PN5D ⁽²⁾) Unit: μm

Nominal Bore (or outer diameter) (mm)		Single Plane Mean Bore Diameter Deviation ΔDmp		Single Plane Mean Outside Diameter Deviation ΔDmp		Deviation of Single Inner Ring Width ΔBs		Inner ring (Outer Ring) Face Runout with Raceway Sia (Seal)
Over	Incl.	High	Low	High	Low	High	Low	Max.
10	18	0	-5	-	-	0	-	5
18	30	0	-6	-	-	0	-	5
30	50	0	-8	0	-7	0	-	5
50	80	0	-9	0	-9	0	-	8
80	120	0	-10	0	-10	0	-	8
120	150	0	-13	0	-11	0	-	10
150	180	0	-13	0	-13	0	-	10
180	250	-	-	0	-15	-	-	10
250	315	-	-	0	-18	-	-	11
315	400	-	-	0	-20	-	-	13

Note: 2. NSK specification

Table 6 Tolerances for BSBD Series double-row bearings (Class P2B ⁽³⁾ of BSF and BSN series) Unit: μm

Nominal Bore Diameter (mm)		Single Plane Mean Bore Diameter Deviation ΔDmp		Single Plane Mean Outside Diameter Deviation ΔDmp		Inner Ring Face Runout with Raceway Sia	Radial Runout of Inner Ring Kia	Width Tolerance	
Over	Incl.	High	Low	High	Low	Max.	Max.	High	Low
10	18	0	-5	0	-10	1.5	1.5	0	-250
18	30	0	-5	0	-10	2.5	2.5	0	-250
30	50	0	-5	0	-10	2.5	2.5	0	-250
50	80	0	-8	0	-15	2.5	2.5	0	-250

Note: 3. NSK specification

for High-Rigidity

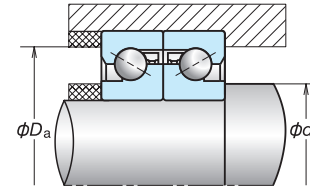
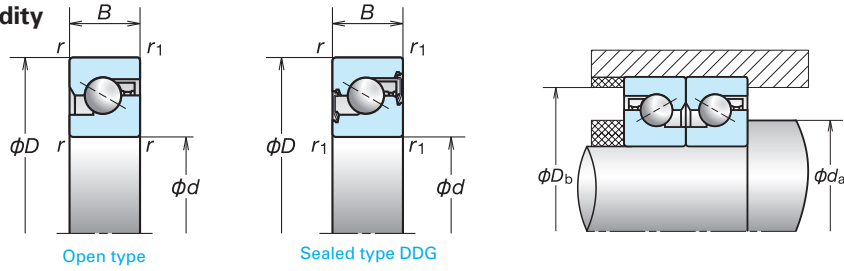

Calculation of preload, axial rigidity and starting torque for bearing arrangements
Multiply by factors in table B.

Table B	DFD	DF	DFT
	DBD	DBB	DBT
Preload factor	1.36	2.00	1.57
Axial rigidity	1.49	2.00	1.89
Starting torque	1.35	2.00	1.55

(Open type)

Bearing Numbers	Boundary Dimensions (mm)				Abutment and Fillet Dimensions (mm)				Recommended Grease Quantities (cc)	Contact angle (degree)	Limiting Speeds ⁽²⁾ (min ⁻¹)		Mass (kg) (approx.)	
	d	D	B	r (Min.)	r1 (Min.)	Db (Max.)	da (Min.)	Da (Max.)			db (Min.)	Grease		Oil
17TAC47C	17	47	15	1	0.6	42	23	41	23	2.2	60	6 900	9 200	0.140
20TAC47C	20	47	15	1	0.6	42	25	41	25	2.2	60	6 900	9 200	0.135
25TAC62C	25	62	15	1	0.6	57	31	56	31	3.0	60	5 200	6 900	0.252
30TAC62C	30	62	15	1	0.6	57	36	56	36	3.2	60	4 900	6 400	0.224
35TAC72C	35	72	15	1	0.6	67	42	66	42	3.8	60	4 100	5 800	0.310
40TAC72C	40	72	15	1	0.6	67	47	66	47	3.9	60	4 100	5 500	0.275
40TAC90C	40	90	20	1	0.6	85	48	84	48	8.8	60	3 500	4 600	0.674
45TAC75C	45	75	15	1	0.6	68	54	67	54	4.2	60	3 700	4 900	0.270
45TAC100C	45	100	20	1	0.6	93	55	92	55	9.7	60	3 000	4 100	0.842
50TAC100C	50	100	20	1	0.6	92	60	91	60	10.2	60	3 000	3 900	0.778
55TAC100C	55	100	20	1	0.6	92	63	91	63	10.2	60	3 000	3 900	0.714
55TAC120C	55	120	20	1	0.6	112	63	111	63	12	60	2 500	3 500	1.23
60TAC120C	60	120	20	1	0.6	112	70	111	70	12	60	2 500	3 500	1.16

(Sealed Type)

Bearing Numbers ⁽¹⁾	Boundary Dimensions (mm)				Abutment and Fillet Dimensions (mm)				Contact angle (degree)	Limiting Speeds ⁽²⁾ (min ⁻¹)		Mass (kg) (approx.)
	d	D	B	r (Min.)	r1 (Min.)	Db (Max.)	da (Min.)	Da (Max.)		db (Min.)	Grease	
* 17TAC47CDDG	17	47	15	1	0.6	42	22	41	22	60	6 900	0.140
* 20TAC47CDDG	20	47	15	1	0.6	42	25	41	25	60	6 900	0.135
* 25TAC62CDDG	25	62	15	1	0.6	57	30	56	30	60	5 200	0.252
30TAC62CDDG	30	62	15	1	0.6	57	36	56	36	60	4 900	0.224
35TAC72CDDG	35	72	15	1	0.6	67	41	66	41	60	4 100	0.310
40TAC72CDDG	40	72	15	1	0.6	67	46	66	46	60	4 100	0.275
40TAC90CDDG	40	90	20	1	0.6	85	47	84	47	60	3 500	0.674
45TAC100CDDG	45	100	20	1	0.6	93	54	92	54	60	3 000	0.842
50TAC100CDDG	50	100	20	1	0.6	92	59	91	59	60	3 000	0.778
55TAC100CDDG	55	100	20	1	0.6	92	63	91	63	60	3 000	0.714

- Note: 1. An asterisk (*) indicates bearings that are also available as non-contact sealed bearings.
 2. Limiting speeds are based on high preload (H). The values shown are valid for all types of bearing arrangement.
 3. To calculate permissible axial load, multiply limiting axial load by 0.7.

Preload (DB and DF Arrangement) (N)	Axial Rigidity (DB and DF Arrangement) (N/μm)	Starting Torque (DB and DF Arrangement) ⁽⁴⁾ (N-m) (reference)	Basic dynamic load rating Ca by number of rows sustaining Fa			Limiting axial load by number of rows sustaining Fa ⁽⁵⁾		
			1 row (kN)	2 rows (kN)	3 rows (kN)	1 row (kN)	2 rows (kN)	3 rows (kN)
H	H	H	1 row (kN)	2 rows (kN)	3 rows (kN)	1 row (kN)	2 rows (kN)	3 rows (kN)
1 450	630	0.09	23.0	37.5	49.5	26.6	53.0	79.5
1 450	630	0.09	23.0	37.5	49.5	26.6	53.0	79.5
1 450	630	0.09	23.0	37.5	49.5	26.6	53.0	79.5
2 280	850	0.15	29.9	48.5	64.5	40.5	81.5	122
2 400	890	0.16	30.5	50.0	66.0	43.0	86.0	129
2 750	1 030	0.18	32.5	53.0	70.5	50.0	100	150
2 860	1 080	0.19	33.5	54.0	72.0	52.0	104	157
3 450	1 150	0.29	62.0	101	134	89.5	179	269
3 100	1 170	0.20	34.5	56.0	74.5	57.0	114	170
4 440	1 340	0.40	64.5	105	140	99.0	198	298
4 650	1 410	0.42	66.0	107	142	104	208	310
4 650	1 410	0.42	66.0	107	142	104	208	310
5 450	1 660	0.49	70.5	115	153	123	246	370
5 450	1 660	0.49	70.5	115	153	123	246	370

Preload (DB and DF Arrangement) (N)	Axial Rigidity (DB and DF Arrangement) (N/μm)	Starting Torque (DB and DF Arrangement) ⁽⁴⁾ (N-m) (reference)	Basic dynamic load rating Ca by number of rows sustaining Fa			Limiting axial load by number of rows sustaining Fa ⁽⁵⁾		
			1 row (kN)	2 rows (kN)	3 rows (kN)	1 row (kN)	2 rows (kN)	3 rows (kN)
H	H	H	1 row (kN)	2 rows (kN)	3 rows (kN)	1 row (kN)	2 rows (kN)	3 rows (kN)
1 450	630	0.09	23.0	37.5	49.5	26.6	53.0	79.5
1 450	630	0.09	23.0	37.5	49.5	26.6	53.0	79.5
1 450	630	0.09	23.0	37.5	49.5	26.6	53.0	79.5
2 280	850	0.15	29.9	48.5	64.5	40.5	81.5	122
2 400	890	0.16	30.5	50.0	66.0	43.0	86.0	129
2 750	1 030	0.18	32.5	53.0	70.5	50.0	100	150
2 860	1 080	0.19	33.5	54.0	72.0	52.0	104	157
3 450	1 150	0.29	62.0	101	134	89.5	179	269
4 440	1 340	0.40	64.5	105	140	99.0	198	298
4 650	1 410	0.42	66.0	107	142	104	208	310
4 650	1 410	0.42	66.0	107	142	104	208	310

4. The starting torque values in the table apply to grease lubricated bearings. Contact seal torque is not included. For oil lubricated bearings, multiply by 1.4.
 5. Abutment and fillet dimensions are recommendable values for the use of standard Machine tool applications. For heavy load applications, please ask NSK

for High-Load Drive Applications

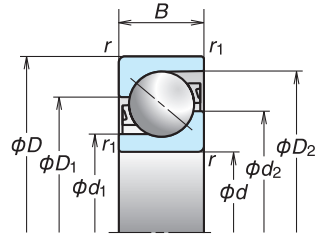

Bearing Numbers ⁽¹⁾	Boundary Dimensions (mm)					Reference Dimensions (mm)				Recommended Grease Quantities (cc/row)	Contact angle (degree)	Limiting Speeds ⁽²⁾ (min ⁻¹)		Mass (kg) (approx.)
	d	D	B	r (Min.)	r ₁ (Min.)	d ₁	d ₂	D ₁	D ₂			Grease	Oil	
	15TAC02D	15	35	11	0.6	0.3	19.1	24.5	26			31.9	1	
20TAC03D	20	52	15	1.1	0.6	27.2	35.3	37.5	46.1	2.7	55	8 300	10 300	0.155
25TAC02D	25	52	15	1	0.6	30.8	38.1	39.6	47.3	3	55	7 700	9 700	0.137
TAC35-3	35	90	23	1.5	1	50.4	64.2	67.1	81.7	14	55	4 600	6 000	0.712
40TAC03D	40	90	23	1.5	1	50.4	64.2	67.1	81.7	14	55	4 600	5 700	0.659
TAC40-3	40	110	27	2	1	62	79.1	82.4	100.6	25	55	3 700	5 000	1.28
45TAC03D	45	100	25	1.5	1	56.5	71.7	74.7	90.8	18	55	4 100	5 200	0.877
TAC45-3	45	110	27	2	1	62	79.1	82.4	100.6	25	55	3 700	4 800	1.21
50TAC03D	50	110	27	2	1	62	79.1	82.4	100.6	25	55	3 700	4 700	1.14
TAC50-3	50	130	31	2.1	1.1	73.9	93.8	98	119	40	55	3 100	4 200	2.00
55TAC03D	55	120	29	2	1	68	86.4	90.2	109.7	32	55	3 400	4 300	1.44
60TAC03D	60	130	31	2.1	1.1	73.9	93.8	98	119	40	55	3 100	3 900	1.80
TAC60-3	60	170	39	2.1	1.1	98.5	123.6	128.7	157.5	85	55	2 400	3 300	4.47
70TAC03D	70	150	35	2.1	1.1	86.3	108.6	113.4	137.8	59	55	2 700	3 400	2.67
75TAC03D	75	160	37	2.1	1.1	92.4	116.2	121	146.2	67	55	2 500	3 200	3.20
80TAC03D	80	170	39	2.1	1.1	98.5	123.6	128.7	157.5	85	55	2 400	3 000	3.80
TAC80-3	80	215	47	3	1.1	124	154.9	160.4	194.5	156	55	1 900	2 600	8.66
100TAC03D	100	215	47	3	1.1	124	154.9	160.4	194.5	156	55	1 900	2 400	7.54
TAC100-3	100	260	55	3	1.1	150.5	186.9	193.4	231.7	254	55	1 500	2 100	14.8
120TAC03D	120	260	55	3	1.1	150.5	186.9	193.4	231.7	254	55	1 500	2 000	13.3
* TAC120-3M	120	300	62	4	1.5	170.8	215.3	224.1	265.7	336	55	1 300	1 800	24.5
* 140TAC03DM	140	300	62	4	1.5	170.8	215.3	224.1	265.7	336	55	1 300	1 700	22.5
* TAC140-3M	140	340	68	4	1.5	197.5	246.2	254.3	298.8	442	55	1 200	1 600	34.5
* 160TAC03DM	160	340	68	4	1.5	197.5	246.2	254.3	298.8	442	55	1 200	1 500	32.0
* TAC160-3M	160	380	75	4	1.5	221.1	275.6	284.9	334.9	624	55	1 000	1 400	46.8
* 180TAC03DM	180	380	75	4	1.5	221.1	275.6	284.9	334.9	624	55	1 000	1 400	43.7

Note: 1. An asterisk (*) indicates bearings that are also available equipped with screw holes for mounting bolts.
 2. Limiting speeds are based on the standard preload of each bearing. The values shown are valid for all types of bearing arrangement.
 3. Preload values for bearings with a bore diameter of 100mm or more as well as for TAC80-3 are based on EL preload.

Multi-row combination calculations

Calculation of preload, axial rigidity and starting torque for bearing arrangements
 Multiply by factors in table B.

Table B

Number of load-sustaining rows	2 rows		3 rows			4 rows		5 rows
	DFD ⊗⊗⊗	DF ⊗⊗⊗	DFT ⊗⊗⊗	DFFD ⊗⊗⊗⊗	DFFF ⊗⊗⊗⊗	DFTD ⊗⊗⊗⊗	DFFT ⊗⊗⊗⊗	DFTT ⊗⊗⊗⊗
	DBD ⊗⊗	DB ⊗⊗	DBT ⊗⊗	DBBD ⊗⊗⊗	DBBB ⊗⊗⊗	DBTD ⊗⊗⊗	DBBT ⊗⊗⊗	DBTT ⊗⊗⊗
Preload factor	1.36	2.00	1.57	2.42	3.00	1.72	2.72	1.83
Axial rigidity	1.49	2.00	1.89	2.51	3.00	2.24	2.97	2.57
Starting torque	1.35	2.00	1.55	2.41	3.00	1.68	2.71	1.77

Preload ⁽³⁾ (DB and DF Arrangement) (N)	Axial Rigidity ⁽³⁾ (DB and DF Arrangement) (N/μm)	Starting Torque ⁽⁴⁾ (DB and DF Arrangement) (N·m)	Basic dynamic load rating Ca by number of rows sustaining Fa					Limiting axial load by number of rows sustaining Fa ⁽⁵⁾				
			1 row (kN)	2 rows (kN)	3 rows (kN)	4 rows (kN)	5 rows (kN)	1 row (kN)	2 rows (kN)	3 rows (kN)	4 rows (kN)	5 rows (kN)
			400	290	0.017	21.0	34.0	45.0	55.5	64.5	18.6	37.5
830	430	0.026	42.5	69.5	92.0	113	132	38.5	77.0	116	154	193
690	430	0.036	37.0	60.0	79.5	97.5	114	36.0	72.5	109	145	181
2 500	780	0.26	113	184	244	299	350	118	235	355	470	590
2 500	780	0.26	113	184	244	299	350	118	235	355	470	590
3 900	970	0.50	166	270	360	440	515	181	360	540	720	905
2 800	830	0.31	133	216	287	350	410	142	283	425	565	710
3 900	970	0.50	166	270	360	440	515	181	360	540	720	905
3 900	970	0.50	166	270	360	440	515	181	360	540	720	905
5 200	1 120	0.78	218	355	470	575	670	242	485	725	965	1 210
4 280	1 060	0.68	190	310	410	500	585	210	420	630	840	1 050
5 200	1 120	0.78	218	355	470	575	670	242	485	725	965	1 210
8 050	1 400	1.5	305	495	660	805	940	390	775	1 170	1 550	1 940
6 400	1 250	1.1	262	425	565	690	810	305	615	920	1 230	1 530
7 230	1 330	1.3	283	460	610	750	875	345	690	1 040	1 380	1 730
8 050	1 400	1.5	305	495	660	805	940	390	775	1 170	1 550	1 940
1 240	880	0.15	420	685	910	1 110	1 300	510	1 020	1 530	2 040	2 550
1 240	880	0.15	420	685	910	1 110	1 300	510	1 020	1 530	2 040	2 550
1 620	1 050	0.21	520	850	1 130	1 380	1 610	680	1 360	2 040	2 720	3 400
1 620	1 050	0.21	520	850	1 130	1 380	1 610	680	1 360	2 040	2 720	3 400
1 710	1 130	0.24	640	1 040	1 380	1 680	1 970	794	1 590	2 380	3 200	3 950
1 710	1 130	0.24	640	1 040	1 380	1 680	1 970	794	1 590	2 380	3 200	3 950
1 850	1 240	0.27	725	1 180	1 570	1 920	2 240	1 040	2 080	3 100	4 150	5 200
1 850	1 240	0.27	725	1 180	1 570	1 920	2 240	1 040	2 080	3 100	4 150	5 200
1 940	1 310	0.30	815	1 330	1 760	2 150	2 520	1 360	2 720	4 100	5 450	6 800
1 940	1 310	0.30	815	1 330	1 760	2 150	2 520	1 360	2 720	4 100	5 450	6 800

4. The starting torque values in the table apply to grease lubrication.
 5. To calculate permissible axial load, multiply limiting axial load by 0.7.

NSKHPS™ BSBD Series

The BSBD Series are double-row bearing units for the support of ball screws that can accurately and quickly position a work piece or a spindle unit.

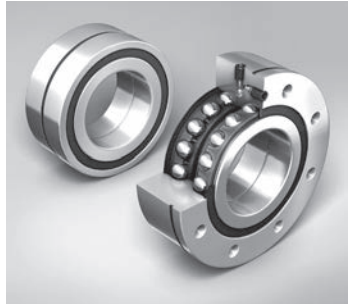

Features

The bearings of this series are double-row angular contact thrust ball bearings with a 60° contact angle and a single outer ring. The specifications are the same as those of the NSKTAC bearings, both series being optimized for the support of ball screws in machine tools. All BSBD Series bearings are equipped with a rubber contact seal and prepacked with high performance grease.

● BSN Type

The BSN type of ball screw support bearings are double row angular contact thrust ball bearings in a back-to-back arrangement, with a single outer ring.

The bearings are prepacked with high performance grease. Lubrication holes allow for relubrication during operation if necessary. The contact seal offers minimized friction and temperature rise while providing excellent sealing performance.

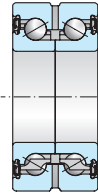

● BSF Type

The BSF type of bearings is equivalent to the BSN range of bearings, with bolt holes on the outer ring for easy direct mounting. Two lubrication holes – one in the outer surface and one in the face of the outer ring – allow for relubrication during operation if required. If not used, these holes are closed off with set screws. An extraction groove on the outer surface of the outer ring aids removal of the bearing.

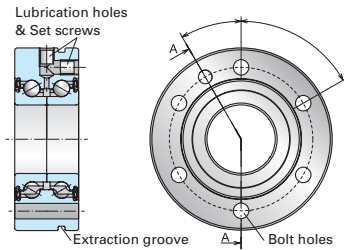

Note: BSF type bearings are supplied with seal and set screws included. Mounting bolts are not included.

BSN Type Single product

Bearing Numbers	Boundary Dimensions (mm)							Abutment and Fillet Dimensions (mm)		Contact Angle (°)	Basic Load Rating (kN)		Limiting ⁽¹⁾ Axial Load (kN)	Preload (N)	Axial Rigidity (N/μm)	Mass (kg)	Limiting speed (min ⁻¹) Greased	Starting torque ⁽²⁾ (N·m) H	Recommended Clamping force (N)
	d	D	B	r	r ₁	φd _a	φD _b	C _a	C _{0a}										
	(min)	(min)	(min)	(min)	(min)	(max)	(Dynamic)	(Static)											
BSN1242	12	42	25	0.6	0.3	15	33	60	18.5	24.0	17.6	720	375	0.20	8 000	0.038	4 030		
BSN1545	15	45	25	0.6	0.3	19	35	60	19.4	26.9	19.4	675	400	0.22	7 100	0.034	4 050		
BSN1747	17	47	25	0.6	0.6	21	37	60	20.3	29.7	21.2	880	450	0.23	6 700	0.05	4 400		
BSN2052	20	52	28	0.6	0.6	24	43	60	26.4	41.0	29.3	1 885	650	0.31	5 800	0.13	7 600		
BSN2557	25	57	28	0.6	0.6	29	48	60	28.3	48.0	34.0	2 245	750	0.36	5 100	0.16	8 100		
BSN3062	30	62	28	0.6	0.6	34	53	60	30.0	55.5	38.5	2 625	850	0.40	4 500	0.19	8 600		
BSN3072	30	72	38	0.6	0.6	35	64	60	60.5	94.0	66.5	4 855	950	0.74	3 900	0.59	11 100		
BSN3572	35	72	34	0.6	0.6	40	62	60	42.0	77.5	52.0	2 630	900	0.66	3 800	0.21	13 500		
BSN4075	40	75	34	0.6	0.6	46	67	60	44.5	88.0	58.5	3 065	1 000	0.65	3 500	0.24	14 100		
BSN4090	40	90	46	0.6	0.6	46	80	60	78.5	135	91.0	7 220	1 200	1.38	3 100	1.02	18 700		
BSN5090	50	90	34	0.6	0.6	56	82	60	48.0	110	71.5	4 020	1 250	0.93	2 800	0.33	15 400		
BSN50110	50	110	54	0.6	0.6	57	98	60	116	219	149	7 435	1 400	2.46	2 500	1.06	19 100		
BSN60110	60	110	45	0.6	0.6	68	100	60	86.5	187	126	4 780	1 300	1.82	2 400	0.50	20 900		

Notes: 1. Permissible axial load equals 0.7 times of limiting axial load.
2. The values indicate starting torque of preloaded bearings, not including seal torque.

NSKHPS BSBD Series

Bearing number Example: **BS F 30 80 DDU H P2B DT**

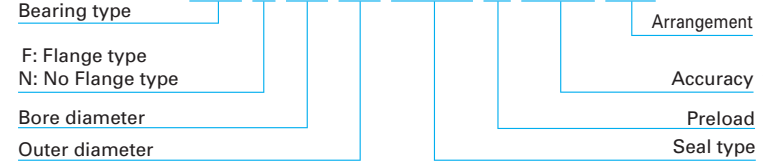

Note: P2B is an accuracy class specific to the BSBD Series, indicating the following:
Running accuracy: ISO Class 2
Others: NSK-specific

● Seal

Rubber contact seal on both sides. Triple lip structure provides high grease sealing performance and dust resistance.

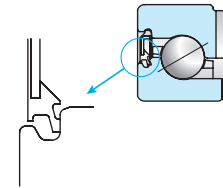

● Matched DT pairs

BSBD bearings are available in matched DT pairs for applications with large external loads or where high rigidity and long life are required. The mating surfaces of the 2-row bearing set are controlled for offset, so as to have no impact on the preload of each individual bearing.

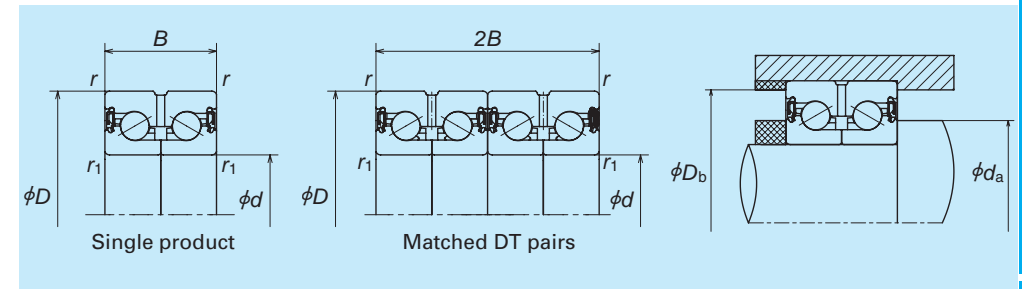
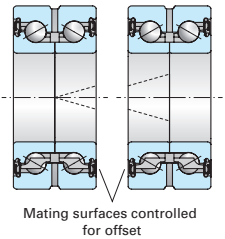

BSN Type Matched DT pairs

Bearing Numbers	Boundary Dimensions (mm)							Abutment and Fillet Dimensions (mm)		Contact Angle (°)	Basic Load Rating (kN)		Limiting ⁽¹⁾ Axial Load (kN)	Axial Rigidity (N/μm)	Mass (kg)	Limiting speed (min ⁻¹) Greased	Starting torque ⁽²⁾ (N·m) H	Recommended Clamping force (N)
	d	D	2B	r	r ₁	φd _a	φD _b	C _a	C _{0a}									
	(min)	(min)	(min)	(min)	(min)	(max)	(Dynamic)	(Static)										
BSN1747-DT	17	47	50	0.6	0.6	21	37	60	33.0	59.5	42.5	790	0.46	6 700	0.10	4 400		
BSN2052-DT	20	52	56	0.6	0.6	24	43	60	43.0	82.0	58.5	1 180	0.62	5 800	0.26	7 600		
BSN2557-DT	25	57	56	0.6	0.6	29	48	60	46.0	96.0	68.0	1 370	0.71	5 100	0.32	8 100		
BSN3062-DT	30	62	56	0.6	0.6	34	53	60	49.0	111	77.0	1 580	0.80	4 500	0.37	8 600		
BSN3072-DT	30	72	76	0.6	0.6	35	64	60	98.0	188	133	1 800	1.47	3 900	1.17	11 100		
BSN3572-DT	35	72	68	0.6	0.6	40	62	60	68.0	155	104	1 630	1.32	3 800	0.41	13 500		
BSN4075-DT	40	75	68	0.6	0.6	46	67	60	72.0	176	117	1 850	1.30	3 500	0.49	14 100		
BSN4090-DT	40	90	92	0.6	0.6	46	80	60	128	269	182	2 300	2.76	3 100	2.03	18 700		
BSN5090-DT	50	90	68	0.6	0.6	56	82	60	78.0	220	143	2 330	1.86	2 800	0.66	15 400		
BSN50110-DT	50	110	108	0.6	0.6	57	98	60	188	440	299	2 690	4.92	2 500	2.11	19 100		

3. Inner rings can be separable easily. Please push or pull bearings by clamping innerring at mounting and dismounting.
4. Abutment and fillet dimensions are recommendable values for the use of standard Machine tool applications. For heavy load applications, please ask NSK.

NSKHPS™ BSBD Series

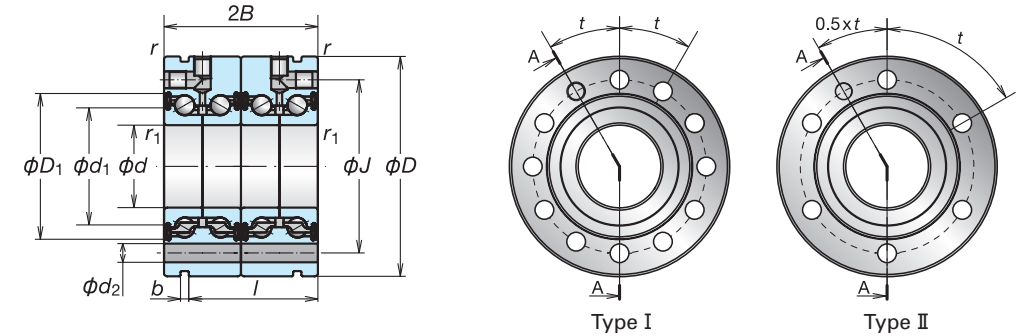
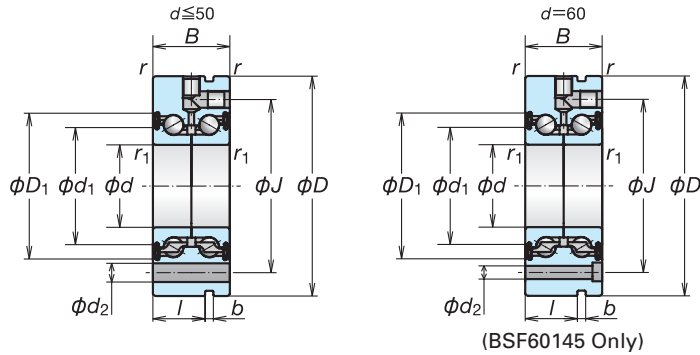

BSF Type Single product

Bearing Numbers	Boundary Dimensions (mm)					Basic Load Rating (kN)		Limiting ⁽¹⁾ Axial Load (kN)	Axial Rigidity (N/μm)	Mass (kg)	Limiting speed (min ⁻¹)	
	d	D	B	r (min)	r ₁ (min)	C _d (Dynamic)	C ₀ (Static)				Grease	Oil
BSF1255	12	55	25	0.6	0.3	18.5	24.0	17.6	375	0.37	8 000	
BSF1560	15	60	25	0.6	0.3	19.4	26.9	19.4	400	0.44	7 100	
BSF1762	17	62	25	0.6	0.6	20.3	29.7	21.2	450	0.46	6 700	
BSF2068	20	68	28	0.6	0.6	26.4	41.0	29.3	650	0.61	5 800	
BSF2575	25	75	28	0.6	0.6	28.3	48.0	34.0	750	0.73	5 100	
BSF3080	30	80	28	0.6	0.6	30.0	55.5	38.5	850	0.79	4 500	
BSF30100	30	100	38	0.6	0.6	60.5	94	66.5	950	1.71	3 900	
BSF3590	35	90	34	0.6	0.6	42.0	77.5	52.0	900	1.20	3 800	
BSF40100	40	100	34	0.6	0.6	44.5	88.0	58.5	1 000	1.49	3 500	
BSF40115	40	115	46	0.6	0.6	78.5	135	91.0	1 200	2.56	3 100	
BSF50115	50	115	34	0.6	0.6	48.0	110	71.5	1 250	1.89	2 800	
BSF50140	50	140	54	0.6	0.6	116	219	149	1 400	4.46	2 500	
BSF60145	60	145	45	0.6	0.6	86.5	187	126	1 300	4.06	2 400	

BSF Type Matched pairs

Bearing Numbers	Boundary Dimensions (mm)					Basic Load Rating (kN)		Limiting ⁽¹⁾ Axial Load (kN)	Axial Rigidity (N/μm)	Mass (kg)	Limiting speed (min ⁻¹)	
	d	D	2B	r (min)	r ₁ (min)	C _d (Dynamic)	C ₀ (Static)				Grease	Oil
BSF1762-DT	17	62	50	0.6	0.6	33.0	59.5	42.5	790	0.890	6 700	
BSF2068-DT	20	68	56	0.6	0.6	43.0	82.0	58.5	1 180	1.17	5 800	
BSF2575-DT	25	75	56	0.6	0.6	46.0	96.0	68.0	1 370	1.46	5 100	
BSF3080-DT	30	80	56	0.6	0.6	49.0	111	77.0	1 580	1.58	4 500	
BSF30100-DT	30	100	76	0.6	0.6	98.0	188	133	1 800	3.41	3 900	
BSF3590-DT	35	90	68	0.6	0.6	68.0	155	104	1 630	2.30	3 800	
BSF40100-DT	40	100	68	0.6	0.6	72.0	176	117	1 850	2.88	3 500	
BSF40115-DT	40	115	92	0.6	0.6	128	269	182	2 300	5.12	3 100	
BSF50115-DT	50	115	68	0.6	0.6	78.0	220	143	2 330	3.78	2 800	
BSF50140-DT	50	140	108	0.6	0.6	188	440	299	2 690	8.92	2 500	

Notes: 1. Permissible axial load equals 0.7 times of limiting axial load. The values refer to the limiting load of the bearing only, without taking the mounting bolts into account.

Reference Dimensions (mm)							Type	Mounting Bolts		Preload (N)	Starting torque ⁽²⁾ (N·m) H	Recommended Clamping Force (N)
d ₁	D ₁	J	d ₂	l	b	t		Bolt Dia.	Number of Bolts			
23.7	32.7	42	6.8	17	3	3 × 120°	II	M6	3	720	0.038	4 030
26.7	35.7	46	6.8	17	3	3 × 120°	II	M6	3	675	0.034	4 050
28.1	37.7	48	6.8	17	3	3 × 120°	II	M6	3	890	0.05	4 400
32.6	43	53	6.8	19	3	4 × 90°	II	M6	4	1 885	0.13	7 600
37.6	48	58	6.8	19	3	4 × 90°	II	M6	4	2 245	0.16	8 100
42.6	53	63	6.8	19	3	6 × 60°	II	M6	6	2 625	0.19	8 600
49.1	64.4	80	8.8	30	3	8 × 45°	II	M8	8	4 855	0.59	11 100
53.1	62.2	75	8.8	25	3	4 × 90°	II	M8	4	2 630	0.21	13 500
55.1	67.2	80	8.8	25	3	4 × 90°	II	M8	4	3 065	0.24	14 100
63.1	80.1	94	8.8	36	3	12 × 30°	II	M8	12	7 220	1.02	18 700
70.1	82.2	94	8.8	25	3	6 × 60°	II	M8	6	4 020	0.33	15 400
78.1	97.5	113	11	45	3	12 × 30°	II	M10	12	7 435	1.06	19 100
83.1	99.3	120	8.8	35	3	8 × 45°	II	M8	8	4 780	0.50	20 900

Reference Dimensions (mm)							Type	Mounting Bolts		Starting torque ⁽²⁾ (N·m) H	Recommended Clamping Force (N)
d ₁	D ₁	J	d ₂	l	b	t		Bolt Dia.	Number of Bolts		
28.1	37.7	48	6.8	42	3	6 × 60°	I	M6	5	0.10	4 400
32.6	43	53	6.8	47	3	8 × 45°	I	M6	7	0.26	7 600
37.6	48	58	6.8	47	3	8 × 45°	I	M6	7	0.32	8 100
42.6	53	63	6.8	47	3	12 × 30°	I	M6	11	0.37	8 600
49.1	64.4	80	8.8	68	3	8 × 45°	II	M8	8	1.17	11 100
53.1	62.2	75	8.8	59	3	8 × 45°	I	M8	7	0.41	13 500
55.1	67.2	80	8.8	59	3	8 × 45°	I	M8	7	0.49	14 100
63.1	80.1	94	8.8	82	3	12 × 30°	II	M8	12	2.03	18 700
70.1	82.2	94	8.8	59	3	12 × 30°	I	M8	11	0.66	15 400
78.1	97.5	113	11	99	3	12 × 30°	II	M10	12	2.11	19 100

2. The values indicate starting torque of preloaded bearings, not including seal torque.
3. Inner rings can be separable easily. Please push or pull bearings by clamping inner ring at mounting and dismounting.

1. End Deflector Type B431
2. Tube Type B437
3. Deflector(bridge) Type B471
4. End Cap Type B485

B-3-2 Dimension Table and Reference Number of Standard Nut Ball Screws

B-3-2.1 End Deflector Type Ball Screws

This product is being applied for a patent.

1. Features

● **Low and less offensive noise**

The average noise level is reduced by more than 6 dB compared with our existing products. At low-speed rotation, the ball screws are nearly silent, while their noise is unprecedentedly low at high-speed rotation.

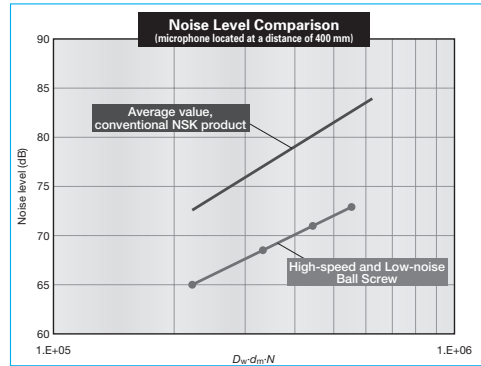

Fig. 1 Comparison of noise level

● **High-speed operation**

Realizes the d-n of 180 000, outstanding for ball screws and far surpassing the 100 000 d-n performance of existing return tube type products. For high-lead ball screws, high-speed operation at over 200 m/min is also possible.

● **Compact**

The external diameter of the ball nut is 30% smaller than our existing models. Compact configurations are possible for low-profile XY tables as well as for other devices and equipment.

● **Grease fitting provided as standard equipment**

The ball screws with shaft diameters equal to or less than $\phi 25$ are equipped with a grease fitting (M5 \times 0.8) as a standard. Lubrication ports are provided in 2 places for ease of maintenance. The ball screws can be easily connected to an integrated lubrication system.

2. Specifications

(1) Ball recirculation system

Fig. 2 shows the structure of the end-deflector recirculation system.

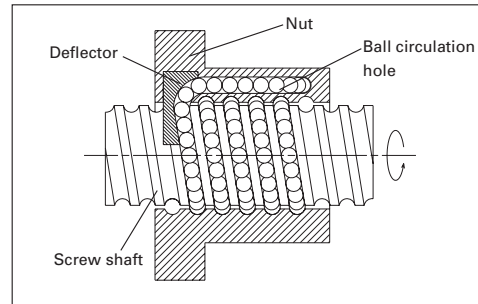

Fig. 2 Structure of end-deflector recirculation system

(2) Accuracy grade and axial play

The available standard accuracy grade and axial play are as follows. Please consult NSK for other grades.

Table 1 Accuracy grade and axial play

Accuracy grade	C0, C1, C2, C3, C5, Ct7
Axial play	Z, 0 mm (preloaded); T, 0.005 mm or less; S, 0.020 mm or less; N, 0.050 mm or less

(3) Allowable d-n value and the criterion of maximum rotational speed

Allowable d-n value and the criterion of maximum rotational speed are shown below. Please consult NSK if the rotational speed exceeds the permissible range below.

Allowable d-n value : 180 000 or less
Standard of rotational speed: 5 000 min⁻¹

Note: Please also review the critical speed. See "Technical Description: Permissible Rotational Speed" (page B47) for details.

(4) Seal

A compact and thin plastic seal is used. Nut outside diameter is compact compare with the return tube recirculation system.

(5) Option

Optional NSK K1 lubrication unit, molded from resin and impregnated with lubrication oil, supplies fresh oil onto ball rolling surfaces, ensuring long-term, maintenance-free operation. Please contact NSK when using NSK K1.

3. Design precautions

When designing the shaft end of a ball screw which diameter is 25 mm or less, or 32 mm or over, and the lead is the same as its shaft diameter, one end of the screw must meet either one of the following conditions. If not, we

cannot install the ball nut on the screw shaft.

- Cut the ball groove through to the shaft end.
- The diameters of bearing journals and the gear or pulley seat must be less than the root diameter of ball groove "dr" specified on the dimension table.

For general precautions regarding ball screws, refer to "Design Precautions"(page B83) and "Handling Precautions"(page B103).

4. Product categories

End deflector type ball screws have the model as follows.

Table 2 End-deflector type ball screw product categories

Nut model	Shape	Flang shape	Nut shape	Preload system
BSS		Circular II, III	Circular	Non-preload, Slight axial play
				P-preload (light preload)

5. Structure of model number and reference number

The following describe the structure of "Model number" and "Reference number for ball screw".

◇ Model number

BSS 10 10 - 2E

Nut model: BSS Effective turns of balls
Screw shaft diameter (mm) Lead (mm)

◇ Reference number for ball screw

W 10 01 - ** P SS - C5 Z 10

Product code Lead (mm)
Screw shaft diameter (mm) Axial play code:
Effective threaded length (in the unit of 100 mm) Z, T, S, N (page B20)
NSK design serial number Accuracy grade:
Preload code: No code, non-preload; P, P-preload (page B5) C0, C1, C2, C3, C5, C7 (Ct7) (page B37 to B42)
End-deflector recirculation system

End deflector type

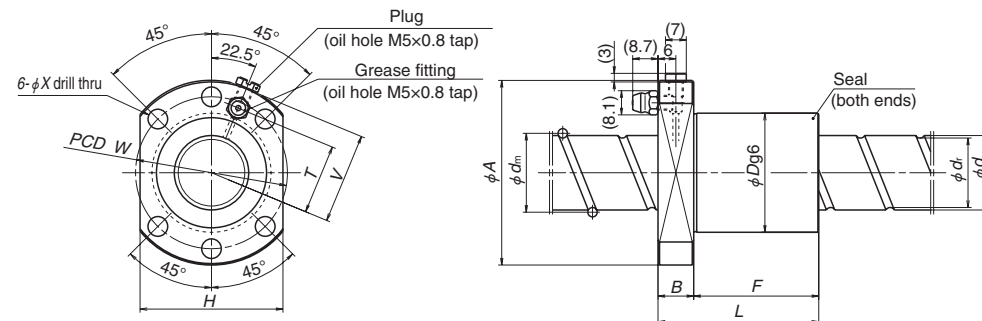
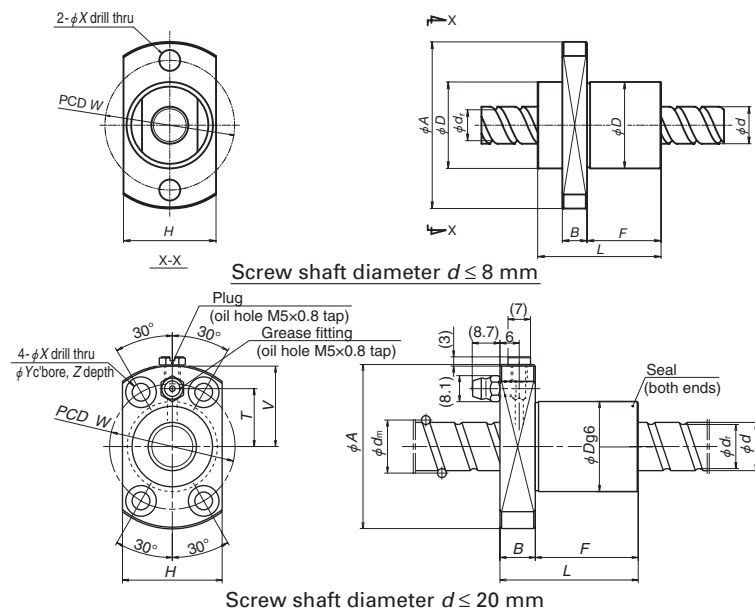

Model No.	Shaft dia. d	Lead l	Ball dia. D_w	Ball circle dia. d_m	Root dia. d_r	Effective turns of balls	Basic load rating (N)		Axial rigidity K (N/ μ m)
							Dynamic	Static	
							C_a	C_{0a}	
BSS0608-2E	6	8	1.2	6.2	4.9	2	550	715	24
BSS0608-4E		8				1 180	1 760	55	
BSS0612-2E		12				2	550	715	22
BSS0612-4E		12				4	1 180	1 760	51
BSS0810-2E	8	10	1.588	8.3	6.6	2	910	1 260	31
BSS0810-4E		10				1 950	3 080	72	
BSS0815-2E		15				2	910	1 260	29
BSS0815-4E		15				4	1 950	3 080	68
BSS1005-3E	10	5	2.000	10.3	8.2	3	2 930	4 790	126
BSS1010-2E		10				2	1 970	3 010	77
BSS1205-3E		5				3	3 200	5 860	146
BSS1210-3E		10				3	3 200	5 860	142
BSS1220-2E	12	20	2.000	12.3	10.2	2	2 150	3 610	83
BSS1230-2E		30				2	2 150	3 610	75
BSS1505-3E		5				3	5 460	10 200	183
BSS1510-3E	15	10	3.175	15.5	12.6	3	5 460	10 200	181
BSS1520-2E		20				2	5 070	8 730	127
BSS1530-2E		30				2	5 070	8 730	116
BSS2005-3E		5				3	8 790	18 500	268
BSS2010-3E	20	10	3.175	20.5	17.2	3	8 790	18 500	268
BSS2020-2E		20				2	5 900	11 700	167
BSS2030-2E		30				2	5 900	11 700	159
BSS2040-2E		40				2	5 900	11 700	147
BSS2060-2E	60	2	5 900	11 700	128				
BSS2505-3E	25	5	3.175	25.5	22.2	3	9 760	23 600	325
BSS2510-4E		10				4	12 800	32 300	437
BSS2520-2E		20				2	6 560	14 600	203
BSS2525-2E		25				2	6 560	14 600	197
BSS2530-2E		30				2	6 560	14 600	194
BSS2550-2E		50				2	6 560	14 600	177

Note: 1) The axial rigidity K in the table above is a theoretical value derived from elastic displacement between screw grooves and balls when axial load is applied to a ball nut for which preload is set at 3% of the basic dynamic load rating (C_a).
For ball screws with shaft diameters less than $\phi 25$, the standard Compact FA PSS type can be available.

Nut entire length L	Nut diameter D	Flange diameter A	Flange width B	Nut length F	Flange dimension		Bolt hole PCD W	Bolt hole dimension			Oil hole distance T
					H	V		X	Y	Z	
					Unit: mm						
16	14	27	4	8	15 (10)	—	21	3.4	—	—	—
24											
20											
32											
18	18	31	4	10	19 (13)	—	25	3.4	—	—	
28											
22											
37											
29	23	43	11	18	26	21	33	4.5	8	4.5	14
32											
30											
43											
50	24	44	11	32	27	21.5	34	4.5	8	4.5	14.5
70											
30											
43											
51	28	51	11	19	31	25	39	5.5	9.5	5.5	18
71											
31											
45											
54	36	62	13	41	38	30.5	49	6.6	11	6.5	23.5
74											
92											
129											
32	40	62	12	20	48	30.5	51	6.6	—	—	23.5
56											
54											
63											
74											
114											

2) The axial play of $\phi 6$ mm and $\phi 8$ mm shaft diameter is only for $T=0.005$ mm max.
3) Dimensions in parentheses are for flat nut configurations.

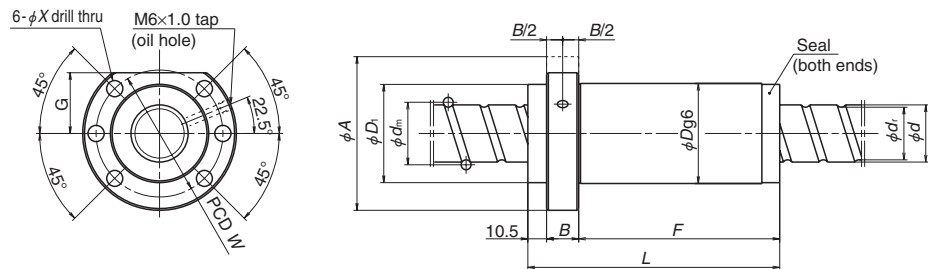

Screw shaft diameter $d = 32$ mm

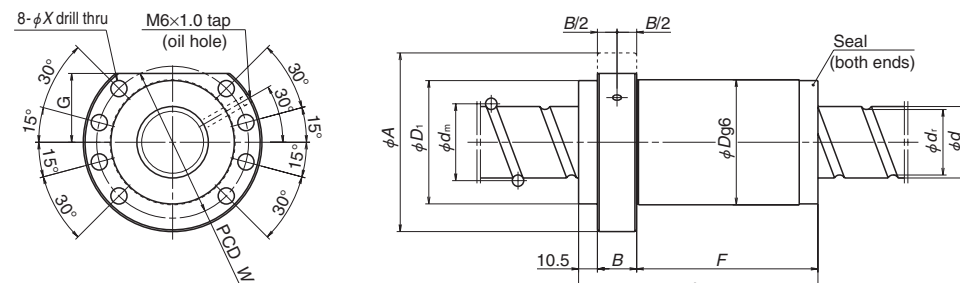

Screw shaft diameter $d \geq 36$ mm

Unit: mm

Model No.	Shaft dia. d	Lead l	Ball dia. D_w	Ball circle dia. d_m	Root dia. d_r	Effective turns of balls	Basic load rating (N)		Axial rigidity K (N/ μ m)
							Dynamic C_n	Static C_{0n}	
BSS3205-4E	32	5	3.175	32.5	29.2	4	14 200	41 400	534
BSS3210-6E		10	5.556	33	27.2	6	43 300	111 000	865
BSS3212-5E		12	5.556	33	27.2	5	36 700	90 800	716
BSS3216-5E		16	5.556	33	27.2	5	36 700	90 800	716
BSS3220-5E		20	5.556	33	27.2	5	36 700	90 800	708
BSS3232-2E		32	5.556	33	27.2	2	15 300	32 400	261
BSS3264-2E	64	5.556	33	27.2	2	15 300	32 400	232	
BSS3605-3E	36	5	3.175	36.5	33.2	3	11 400	34 100	433
BSS3610-6E		10	6.35	37	30.4	6	55 200	142 000	970
BSS3612-6E		12	6.35	37	30.4	6	55 200	142 000	967
BSS3616-6E		16	6.35	37	30.4	6	55 200	142 000	961
BSS3620-6E		20	6.35	37	30.4	6	55 200	142 000	959
BSS4010-5E		40	10	6.35	41	34.4	5	49 300	130 000
BSS4012-5E	12		5				49 300	130 000	873
BSS4016-5E	16		5				49 300	130 000	875
BSS4020-5E	20		5				49 300	130 000	868
BSS4025-4E	25		4				40 100	103 000	686
BSS4030-3E	30		3				30 600	74 000	505
BSS4040-2E	40	2	20 600	46 600	319				
BSS4080-2E	80	2	20 600	46 600	286				
BSS4510-5E	45	10	6.35	46	39.4	5	51 400	146 000	961
BSS4512-5E		12				5	51 400	146 000	959
BSS4516-5E		16				5	51 400	146 000	955
BSS4520-5E		20				5	51 400	146 000	950
BSS4525-5E		25				5	51 400	146 000	954
BSS4530-4E		30				4	41 800	116 000	752
BSS5010-4E	50	10	6.35	51	44.4	4	44 600	129 000	836
BSS5012-4E		12				4	44 600	129 000	944
BSS5016-4E		16				4	44 600	129 000	832
BSS5020-4E		20				4	44 600	129 000	837
BSS5025-4E		25				4	44 600	129 000	828
BSS5030-4E		30				4	44 600	129 000	821
BSS5050-2E	50	2	22 800	58 300	383				
BSS50100-2E	100	2	22 800	58 300	342				

Note: The axial rigidity K in the table above is a theoretical value derived from elastic displacement between screw grooves and balls when axial load is applied to a ball nut for which preload is set at 3% of the basic dynamic load rating (C_n).

Nut entire length L	Nut diameter D	Seal section diameter D_s	Flange diameter A	Flange width B	Nut length F	Notched flange G	Bolt hole PCD W	Bolt hole dimension X	
55	56	55	86	12	32.5	34	71	9	
104					18				75.5
103					18				74.5
122					18				93.5
141					18				112.5
94					18				65.5
153	18	124.5							
50	65	64	95	22	27.5	36	80	9	
109					22				76.5
120					22				87.5
143					22				110.5
166					22				133.5
99					22				66.5
108	70	69	100	22	66.5	38.5	85	9	
127					75.5				
146					94.5				
146					113.5				
145					112.5				
134					101.5				
110	77.5								
184	151.5								
99	75	74	110	22	66.5	43	93	11	
108					75.5				
127					94.5				
146					113.5				
146					112.5				
170					137.5				
164	131.5								
89	82	81	118	22	56.5	46	100	11	
96					63.5				
111					78.5				
126					93.5				
145					112.5				
164					131.5				
130	97.5								
224	191.5								

End deflector type

B-3-2.2 Return Tube Type Ball Screws

1. Features

Return tube type is a standard way of ball recirculation system for ball screws. It has various combinations of shaft diameter and lead.

2. Specifications

(1) Ball recirculation system

The structure of return tube recirculation system is shown below.

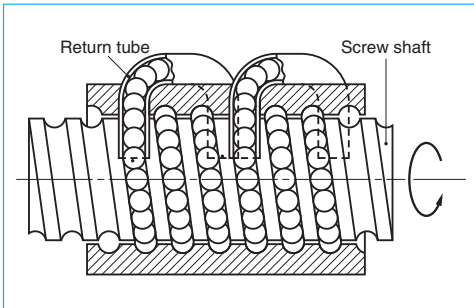

Fig.1 Structure of return tube recirculation system

(2) Accuracy grade and axial play

The available standard accuracy grade and axial play are shown in **Table 1**. Please consult NSK for other grades.

(3) Allowable d-n value and the criterion of maximum rotational speed

Allowable d-n value and the criterion of maximum rotational speed are shown below. Please consult NSK if the rotational speed exceeds the permissible range below. Basic measures must be taken for the high-speed ball screws respectively.

- Allowable d-n value :
- Standard specification ; 70 000 or less
- High-speed specification; 100 000 or less
- Standard of rotational speed : 3 000 min⁻¹

Note: Please also review the critical speed. Refer to "Technical Description: Permissible Rotational Speed" (page B47) for details.

(4) Option

A type equipped with NSK K1 lubrication unit is also available.

(5) Other specifications

Please consult NSK for other specifications not listed in the dimension tables.

3. Product categories

There are four different preloaded systems with several models. Since the leads are in the range from 1/2 to the same length of the shaft

Table 1 Accuracy grade and axial play

Accuracy grade	SFT, PFT, ZFT, DFT: C0, C1, C2, C3, C5, Ct7 LSFT, LPFT, LDFT: C1, C2, C3, C5, Ct7 (Ct7 is not included in DFT, LDFT)
Axial play	Z, 0 mm (preloaded); T, 0.005 mm or less; S, 0.020 mm or less; N, 0.050 mm or less

Table 2 Return tube type ball screws product categories

Nut model	Shape	Flange shape	Nut shape	Preload system
SFT		Flanged d=16mm or under	Circle dia.	Non-preload, Slight axial play
PFT		Rectangle d=20mm or over Circular I, II		P-preload (light preload) Spacer ball 1:1
ZFT		Flanged Circular I, II	Circle dia.	Z-preload (medium preload)

Nut model	Shape	Flange shape	Nut shape	Preload system
DFT		Flanged Circular I, II	Circular	D-preload (medium preload) (heavy preload)
LSFT		Flanged d=20mm or under Rectangle d=25mm or over Circular II	d=20mm or under Circular	Non-preload, Slight axial play
LPFT			d=25mm or over Tube- projecting type	P-preload (light preload) Spacer ball 1:1
LDFT		Flanged Circular II	Circular	D-preload (medium preload) (heavy preload)

diameter (medium-high helix lead), LSFT, LPFT, LDFT Type ball screws are suitable for high-speed operation.

4. Structure of model number and reference number

The followings describe the structure of "Model number" and "Reference number for ball screw".

◇ Model number

SFT 14 05 - 2.5

Nut model:
SFT, PFT, ZFT, DFT
LSFT, LPFT, LDFT

Screw shaft diameter (mm)

Effective turns of balls (Note)

Lead (mm)

Note: In case of Z-preload, the number here is twice as large as the effective turns of balls.

◇ Reference number for ball screw

W 14 01 - ** P - C3 Z 5

Product code

Screw shaft diameter (mm)

Effective threaded length (in the unit of 100 mm)

NSK design serial number

Preload code:
No code, non-preload; P, P-preload
Z, Z-preload; D, D-preload (page B5)

Lead (mm)

Axial play code:
Z, T, S, N (page B20)

Accuracy grade code:
C0, C1, C2, C3, C5, C7 (Ct7)
(page B37 to B42)

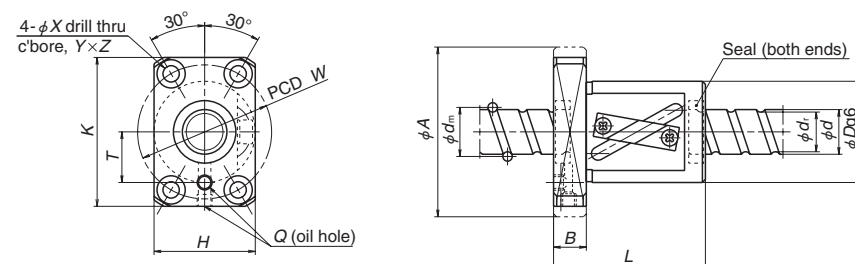
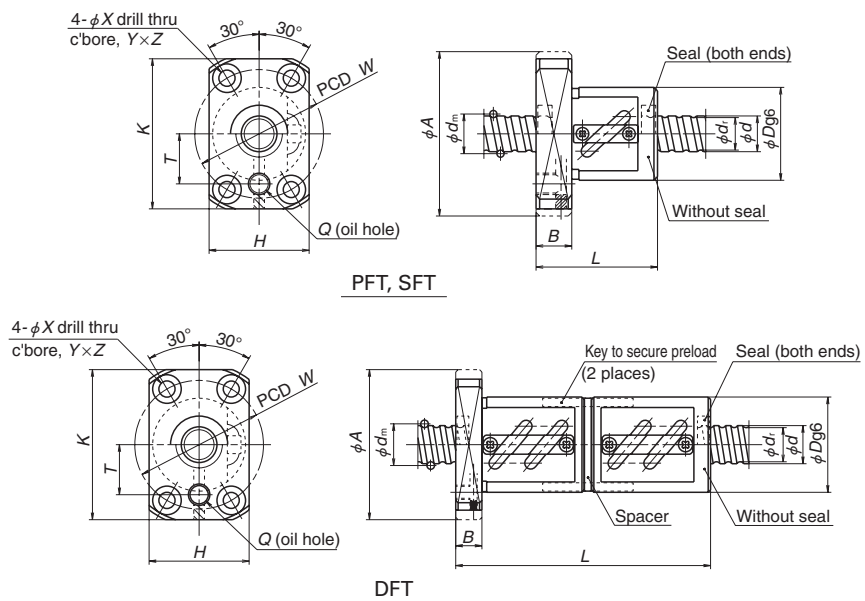

LPFT, LSFT

Unit: mm

Model No.	Preload system	Shaft dia. <i>d</i>	Lead <i>l</i>	Ball dia. <i>D_w</i>	Ball circle dia. <i>d_m</i>	Root dia. <i>d_r</i>	Effective turns of balls Turns × Circuits	Basic load rating (N)		Axial rigidity <i>K</i> (N/μm)	
								Dynamic <i>C_d</i>	Static <i>C_s</i>		
* PFT 1004-2.5 SFT 1004-2.5	P Clearance	10	4	2.000	10.3	8.2	2.5×1	1 730	2 230	76	
								2 740	4 450	90	
PFT 1204-3 SFT 1204-2.5 SFT 1204-3	P Clearance Clearance	12	4	2.381	12.3	9.8	2.5×1	2 370	3 160	89	
								1.5×2	2 770	3 790	106
								2.5×1	3 760	6 310	106
								1.5×2	4 390	7 580	126
* PFT 1205-2.5 PFT 1205-3 SFT 1205-2.5 SFT 1205-3	P P Clearance Clearance	12	5	2.381	12.3	9.8	2.5×1	2 370	3 160	89	
								1.5×2	2 770	3 790	106
								2.5×1	3 760	6 310	106
								1.5×2	4 390	7 580	126
* LPFT 1210-2.5 LSFT 1210-2.5	P Clearance	10	2.381	12.5	10.0	2.5×1	2 360	3 240	90		
							3 750	6 480	110		
* PFT 1405-2.5 SFT 1405-2.5 PFT 1405-5 SFT 1405-5	P Clearance P Clearance	14	5	3.175	14.5	11.2	2.5×1	4 280	5 840	116	
								2.5×1	6 790	11 700	140
								2.5×2	7 770	11 700	225
								2.5×2	12 300	23 400	274
* LPFT 1408-2.5 LSFT 1408-2.5	P Clearance	8	3.175	14.5	11.2	2.5×1	4 280	5 840	120		
							6 790	11 700	140		
* LPFT 1510-2.5 LSFT 1510-2.5	P Clearance	15	10	3.175	15.5	12.2	2.5×1	4 450	6 380	127	
								7 070	12 800	150	
PFT 1604-3 SFT 1604-2.5 DFT 1604-2.5 PFT 1604-5 SFT 1604-3 DFT 1604-3	P Clearance D P Clearance D	16	4	2.381	16.3	13.8	1.5×2	3 170	5 150	135	
								2.5×1	4 300	8 530	134
								2.5×1	4 300	8 530	263
								2.5×2	4 920	8 530	215
								1.5×2	5 040	10 300	160
								1.5×2	5 040	10 300	315

- Notes: 1. Nut flange for shaft diameter 16 mm or smaller comes in rectangular shape.
 2. Seals are equipped as a standard for LSFT and LPFT of shaft diameter 20 mm or smaller. The outside dimensions are the same as those of without seals.
 3. The right turn screw is standard. "L" is added to the end of the model code for the left turn screw.

Nut entire length <i>L</i>	Nut diameter <i>D</i>	Flanged diameter <i>A</i>	Flanged width <i>B</i>	Ball nut dimensions			Bolt hole PCD <i>W</i>	Oil hole length <i>T</i>	Oil hole <i>Q</i>
				Rectangle flanged diameter <i>H</i>	Rectangle flanged diameter <i>K</i>	Bolt hole dimension <i>X</i> <i>Y</i> <i>Z</i>			
34	26	46	10	28	42	4.5 8 4.5	36	14	M6×1
38	30	50	10	32	45	4.5 8 4.5	40	15	M6×1
44									
38									
44									
40	30	50	10	32	45	4.5 8 4.5	40	15	M6×1
48									
40									
48									
50	30	50	10	32	45	4.5 8 4.5	40	15	M6×1
40	34	57	11	34	50	5.5 9.5 5.5	45	17	M6×1
40									
55									
55									
46	34	57	11	34	50	5.5 9.5 5.5	45	17	M6×1
51	34	57	11	34	50	5.5 9.5 5.5	45	17	M6×1
45	34	57	11	34	50	5.5 9.5 5.5	45	17	M6×1
38									
70									
50									
45	36	57	11	34	50	5.5 9.5 5.5	45	17	M6×1
45									
85									

4. The axial rigidity *K* in the table above is a theoretical value obtained from the elastic deformation between screw groove and ball when the axial load is 30% of the basic dynamic load rating (*C_d*) with non-preload, 10% with D-preload, and 5% with P-preload. Refer to "Technical Description" (page B37) if the axial load and preload differ from the conditions above, or when the deformation of the ball nut body must be considered.
 5. For PFT and LPFT, the basic load ratings differ from the other models as the spacer balls are installed.
 6. The models marked with * (asterisk) are available in the FA type standard ball screws with finished shaft end.
 7. Preload system: P, Oversize ball preload; D, Double nut preload (See page B5.)

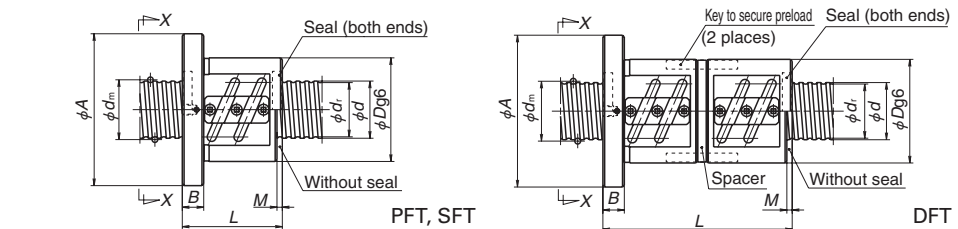

View X-X

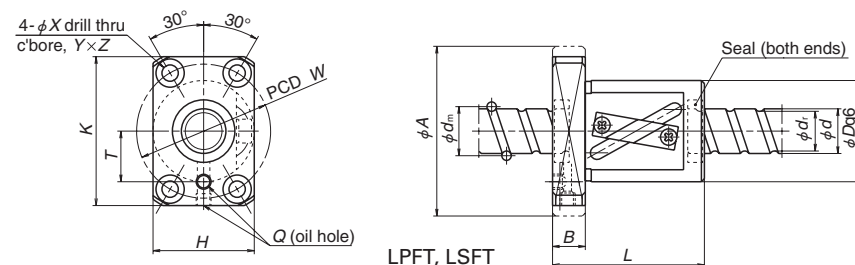
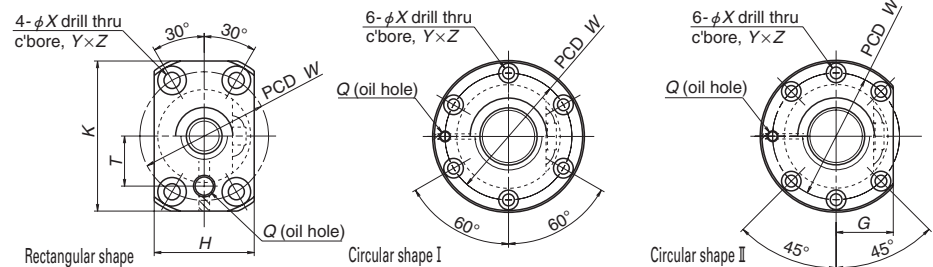

Unit: mm

Model No.	Preload system	Shaft dia. <i>d</i>	Lead <i>l</i>	Ball dia. <i>D_w</i>	Ball circle dia. <i>d_m</i>	Root dia. <i>d_r</i>	Effective turns of balls × Circuits	Basic load rating (N)		Axial rigidity <i>K</i> (N/μm)
								Dynamic <i>C_e</i>	Static <i>C_{0a}</i>	
PFT 1605-3	P	16	5	3.175	16.5	13.2	1.5×2	5 400	8 100	158
SFT 1605-2.5	Clearance						2.5×1	7 330	13 500	158
DFT 1605-2.5	D						2.5×1	7 330	13 500	311
PFT 1605-5	P						2.5×2	8 380	13 500	258
SFT 1605-3	Clearance						1.5×2	8 570	16 200	188
DFT 1605-3	D						1.5×2	8 570	16 200	370
SFT 1605-5	Clearance		2.5×2	13 300	27 000	307				
DFT 1605-5	D		2.5×2	13 300	27 000	603				
PFT 1606-2.5	P		6	3.175	16.5	13.2	2.5×1	4 620	6 750	133
SFT 1606-2.5	Clearance						2.5×1	7 330	13 500	158
DFT 1606-2.5	D						2.5×1	7 330	13 500	311
SFT 1606-3	Clearance						1.5×2	8 570	16 200	188
DFT 1606-3	D	1.5×2					8 570	16 200	370	
* LPFT 1616-1.5	P	16					3.175	16.75	13.4	1.5×1
LSFT 1616-1.5	Clearance		4 710	8 110	100					
SFT 2004-2.5	Clearance	20	4	2.381	20.3	17.8	2.5×1	4 740	10 700	160
DFT 2004-2.5	D						2.5×1	4 740	10 700	315
* PFT 2004-5	P						2.5×2	5 420	10 700	260
SFT 2004-5	Clearance						2.5×2	8 600	21 500	309
DFT 2004-5	D						2.5×2	8 600	21 500	608
PFT 2005-3	P						5	3.175	20.5	17.2
SFT 2005-2.5	Clearance		2.5×1	8 230	17 100	190				
DFT 2005-2.5	D		2.5×1	8 230	17 100	376				
* PFT 2005-5	P		2.5×2	9 410	17 100	311				
SFT 2005-3	Clearance		1.5×2	9 620	20 600	227				
DFT 2005-3	D		1.5×2	9 620	20 600	446				
SFT 2005-5	Clearance		2.5×2	14 900	34 300	370				
DFT 2005-5	D	2.5×2	14 900	34 300	726					

- Notes: 1. Nut flange for shaft diameter 16 mm or smaller comes in rectangular shape. It comes in circular shape I and circular shape II for shaft diameter 20 mm or larger. Select a flange that is suitable for the space available for nut installation.
 2. If there is no seal for PFT, SFT, and DFT, the nut length "L" is shortened by dimension "M".
 3. Seals are equipped as a standard for LSFT and LPFT of shaft diameter 20 mm or smaller. The outside dimensions are the same as those of without seals.
 4. The right turn screw is standard. "L" is added to the end of the model code for the left turn screw.

Nut entire length <i>L</i>	Nut diameter <i>D</i>	Flanged diameter <i>A</i>	Flanged width <i>B</i>	Notched flange <i>G</i>	Rectangle flanged diameter		Seal dimension <i>M</i>	Bolt hole dimension			Bolt hole PCD <i>W</i>	Oil hole length <i>T</i>	Oil hole <i>Q</i>
					<i>H</i>	<i>K</i>		<i>X</i>	<i>Y</i>	<i>Z</i>			
52	40	63	11	—	40	55	—	5.5	9.5	5.5	51	20	M6×1
42													
77													
57													
52													
97													
57													
107													
44													
44													
86													
56													
110													
56	40	63	12	—	40	55	—	5.5	9.5	5.5	51	17	M6×1
37													
69													
49													
49													
93													
52													
41													
76													
56													
52													
97													
56													
106													
52	44	67	11	26	—	—	3	5.5	9.5	5.5	55	—	M6×1
41													
76													
56													
52													
97													
56													
106													

5. The axial rigidity *K* in the table above is a theoretical value obtained from the elastic deformation between screw groove and ball when the axial load is 30% of the basic dynamic load rating (*C_e*) with non-preload, 10% with D-preload, and 5% with P-preload. Refer to "Technical Description" (page B37) if the axial load and preload differ from the conditions above, or when the deformation of the ball nut body must be considered.
 6. For PFT and LPFT, the basic load ratings differ from the other models as the spacer balls are installed.
 7. The models marked with * (asterisk) are available in the FA or SA type standard ball screws with finished shaft end.
 8. Preload system: P, Oversize ball preload; D, Double nut preload (See page B5.)

Return tube type

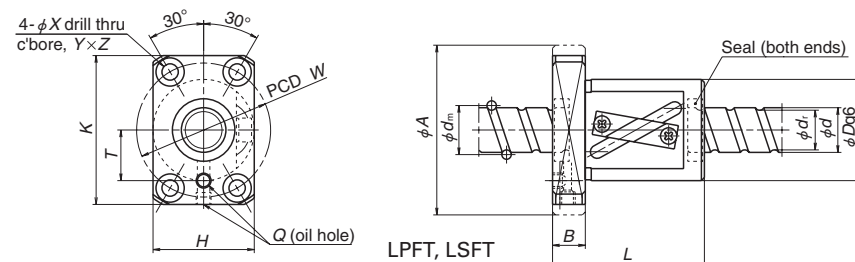
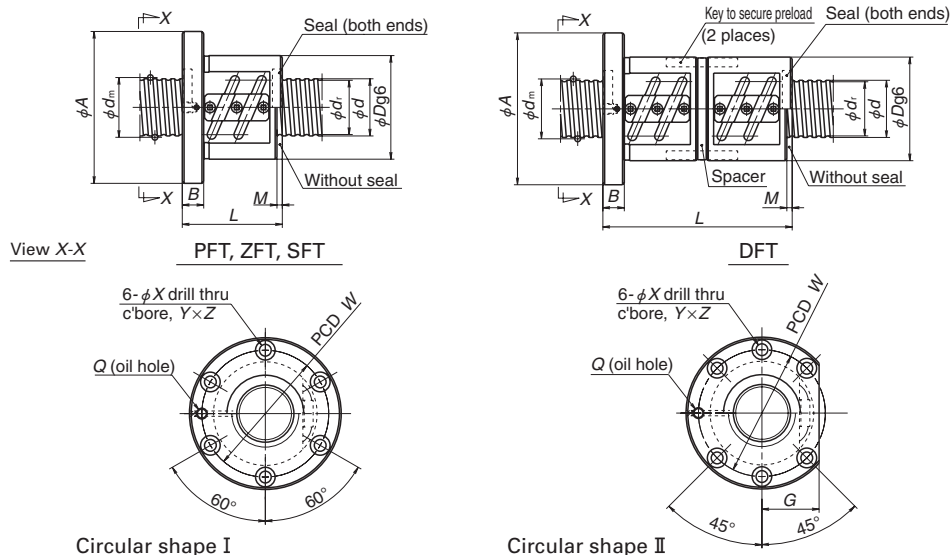

Unit: mm

Model No.	Preload system	Shaft dia. <i>d</i>	Lead <i>l</i>	Ball dia. <i>D_w</i>	Ball circle dia. <i>d_m</i>	Root dia. <i>d_r</i>	Effective turns of balls Turns × Circuits	Basic load rating (N)		Axial rigidity <i>K</i> (N/μm)							
								Dynamic <i>C_a</i>	Static <i>C_{0a}</i>								
PFT 2006-2.5	P	20	6	3.969	20.5	16.4	2.5×1	6 900	10 500	164							
PFT 2006-3	P						1.5×2	8 080	12 700	195							
SFT 2006-2.5	Clearance						2.5×1	11 000	21 100	195							
DFT 2006-2.5	D						2.5×1	11 000	21 100	384							
SFT 2006-3	Clearance						1.5×2	12 800	25 300	232							
DFT 2006-3	D						1.5×2	12 800	25 300	456							
PFT 2008-2.5	P		8	3.969	20.5	16.4	2.5×1	6 900	10 500	164							
SFT 2008-2.5	Clearance						2.5×1	11 000	21 100	195							
DFT 2008-2.5	D						2.5×1	11 000	21 100	384							
SFT 2008-3	Clearance						1.5×2	12 800	25 300	232							
DFT 2008-3	D						1.5×2	12 800	25 300	456							
* LPFT 2010-2.5	P						10	3.969	21.0	16.9	2.5×1	6 800	10 800	169			
LSFT 2010-2.5	Clearance	10 900	21 700	202													
LPFT 2016-2.5	P	16	3.969	21.0	16.9	2.5×1					6 880	10 800	169				
LSFT 2016-2.5	Clearance					10 900					21 700	202					
* LPFT 2020-1.5	P					20					3.969	21.0	16.9	1.5×1	5 370	8 450	137
LSFT 2020-1.5	Clearance													7 040	12 700	127	
SFT 2504-2.5	Clearance						4	2.381	25.3	22.8				2.5×1	5 270	13 600	193
ZFT 2504-5	Z													2.5×1	5 270	13 600	379
* PFT 2504-5	P	2.5×2	6 020	13 600	312												
SFT 2504-5	Clearance	2.5×2	9 560	27 200	374												
ZFT 2504-10	Z	2.5×2	9 560	27 200	735												
PFT 2505-3	P	5	3.175	25.5	22.2	1.5×2					6 730	12 800	223				
SFT 2505-2.5	Clearance					2.5×1	9 130	21 900	231								
ZFT 2505-5	Z					2.5×1	9 130	21 900	454								
* PFT 2505-5	P					2.5×2	10 400	21 900	372								
SFT 2505-3	Clearance					1.5×2	10 700	25 700	271								
DFT 2505-3	D					1.5×2	10 700	25 700	532								
PFT 2505-7.5	P					2.5×3	14 800	32 800	544								
SFT 2505-5	Clearance					2.5×2	16 600	43 700	447								
ZFT 2505-10	Z					2.5×2	16 600	43 700	876								
SFT 2505-7.5	Clearance					2.5×3	23 500	65 600	654								

- Notes: 1. Nut flange for shaft diameter 20 mm or larger comes in circular shape I and circular shape II. Select a flange that is suitable for the space available for nut installation.
 2. If there is no seal for PFT, SFT, and DFT, the nut length "L" is shortened by dimension "M".
 3. Seals are equipped as a standard for LSFT and LPFT of shaft diameter 20 mm or smaller. The outside dimensions are the same as those of without seals.
 4. The right turn screw is standard. "L" is added to the end of the model code for the left turn screw.

Ball nut dimensions													
Nut entire length <i>L</i>	Nut diameter <i>D</i>	Flanged diameter <i>A</i>	Flanged width <i>B</i>	Notched flange <i>G</i>	Rectangle flanged diameter		Seal dimension <i>M</i>	Bolt hole dimension			Bolt hole PCD <i>W</i>	Oil hole length <i>T</i>	Oil hole <i>Q</i>
					<i>H</i>	<i>K</i>		<i>X</i>	<i>Y</i>	<i>Z</i>			
44													
56													
44	48	71	11	27	—	—	3	5.5	9.5	5.5	59	—	M6×1
86													
56													
110													
54	48	75	13	28	—	—	5	6.6	11	6.5	61	—	M6×1
54													
102													
64													
120													
54	46	74	13	—	46	66	—	6.6	11	6.5	59	24	M6×1
72	46	74	13	—	46	66	—	6.6	11	6.5	59	24	M6×1
63	46	74	13	—	46	66	—	6.6	11	6.5	59	24	M6×1
36													
48	46	69	11	26	—	—	3	5.5	9.5	5.5	57	—	M6×1
48													
48													
72													
52													
40													
55													
55													
52	50	73	11	28	—	—	3	5.5	9.5	5.5	61	—	M6×1
102													
70													
55													
85													
70													

5. The axial rigidity *K* in the table above is a theoretical value obtained from the elastic deformation between screw groove and ball when the axial load is 30% of the basic dynamic load rating (*C*) with non-preload, 10% with D-preload, and 5% with P-preload. Refer to "Technical Description" (page B37) if the axial load and preload differ from the conditions above, or when the deformation of the ball nut body must be considered.
 6. For PFT and LPFT, the basic load ratings differ from the other models as the spacer balls are installed.
 7. The models marked with * (asterisk) are available in the FA or SA type standard ball screws with finished shaft end.
 8. Preload system: P, Oversize ball preload; Z, Offset preload; D, Double nut preload (See page B5.)

Return tube type

View X-X

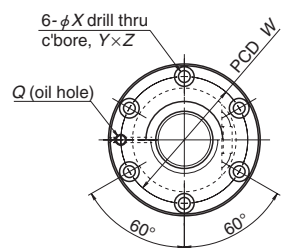

Circular shape I

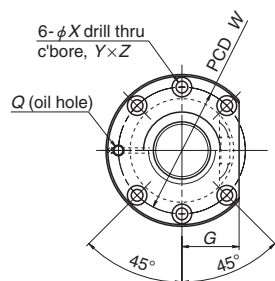

Circular shape II

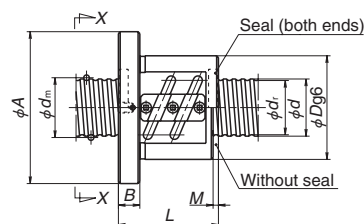

PFT, ZFT, SFT

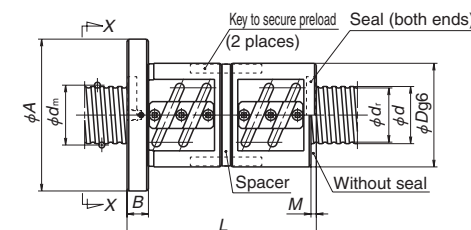

DFT

Unit: mm

Model No.	Preload system	Shaft dia. <i>d</i>	Lead <i>l</i>	Ball dia. <i>D_w</i>	Ball circle dia. <i>d_m</i>	Root dia. <i>d_r</i>	Effective turns of balls Turns × Circuits	Basic load rating (N)		Axial rigidity <i>K</i> (N/μm)					
								Dynamic <i>C_d</i>	Static <i>C_{0a}</i>						
PFT 2506-3	P	25	6	3.969	25.5	21.4	1.5×2	9 070	16 100	235					
SFT 2506-2.5	Clearance						2.5×1	12 300	26 800	235					
ZFT 2506-5	Z						2.5×1	12 300	26 800	462					
* PFT 2506-5	P						2.5×2	14 100	26 800	383					
SFT 2506-3	Clearance						1.5×2	14 400	32 100	280					
DFT 2506-3	D						1.5×2	14 400	32 100	551					
SFT 2506-5	Clearance						2.5×2	22 300	53 500	456					
ZFT 2506-10	Z						2.5×2	22 300	53 500	896					
PFT 2508-2.5	P						25	8	4.762	25.5	20.5	2.5×1	9 940	16 000	203
PFT 2508-3	P											1.5×2	11 600	19 000	234
SFT 2508-2.5	Clearance	2.5×1	15 800	32 000	242										
ZFT 2508-5	Z	2.5×1	15 800	32 000	476										
SFT 2508-3	Clearance	1.5×2	18 500	38 100	286										
DFT 2508-3	D	1.5×2	18 500	38 100	562										
PFT 2510-2.5	P	25	10	4.762	25.5	20.5						2.5×1	9 940	16 000	203
ZFT 2510-3	Z											1.5×1	10 200	19 000	291
PFT 2510-3	P											1.5×2	11 600	19 000	234
SFT 2510-2.5	Clearance											2.5×1	15 800	32 000	242
DFT 2510-2.5	D						2.5×1	15 800	32 000	475					
SFT 2510-3	Clearance						1.5×2	18 500	38 100	286					
DFT 2510-3	D						1.5×2	18 500	38 100	562					
SFT 2510-3.5	Clearance						3.5×1	21 100	44 200	330					
DFT 2510-3.5	D						3.5×1	21 100	44 200	649					

Notes: 1. Nut flange for shaft diameter 20 mm or larger comes in circular shape I and circular shape II. Select a flange that is suitable for the space available for nut installation.

2. If there is no seal for PFT, ZFT, SFT, and DFT, the nut length "L" is shortened by dimension "M".

3. The right turn screw is standard. "L" is added to the end of the model code for the left turn screw.

Ball nut dimensions																				
Nut entire length <i>L</i>	Nut diameter <i>D</i>	Flanged diameter <i>A</i>	Flanged width <i>B</i>	Notched flange <i>G</i>	Seal dimension <i>M</i>	Bolt hole dimension			Bolt hole PCD <i>W</i>	Oil hole <i>Q</i>										
						<i>X</i>	<i>Y</i>	<i>Z</i>												
56	53	76	11	29	3	5.5	9.5	5.5	64	M6×1										
44																				
62																				
62																				
56																				
110																				
62																				
98																				
56											58	85	13	32	5	6.6	11	6.5	71	M6×1
69																				
56																				
80																				
69																				
133																				
67	58	85	15	32	8	6.6	11	6.5	71	M6×1										
81																				
81																				
67																				
127																				
81																				
151																				
77																				
147																				

4. The axial rigidity *K* in the table above is a theoretical value obtained from the elastic deformation between screw groove and ball when the axial load is 30% of the basic dynamic load rating (*C_d*) with non-preload, 10% with D-preload, and 5% with P-preload. Refer to "Technical Description" (page B37) if the axial load and preload differ from the conditions above, or when the deformation of the ball nut body must be considered.

5. For PFT, the basic load ratings differ from the other models as the spacer balls are installed.

6. The models marked with * (asterisk) are available in the SA type standard ball screws with finished shaft end.

7. Preload system: P, Oversize ball preload; Z, Offset preload; D, Double nut preload (See page B5.)

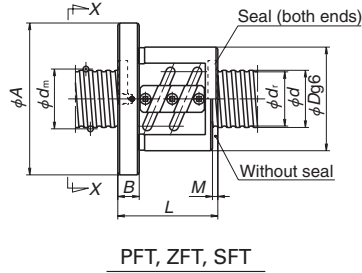

PFT, ZFT, SFT

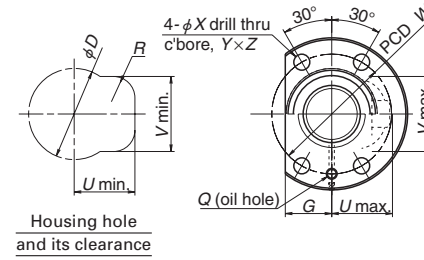

Housing hole and its clearance

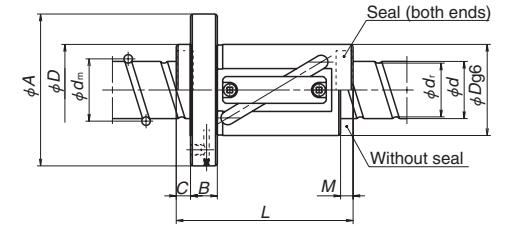

LPFT, LSFT

View X-X

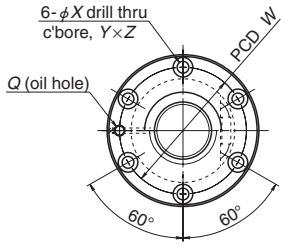

Circular shape I

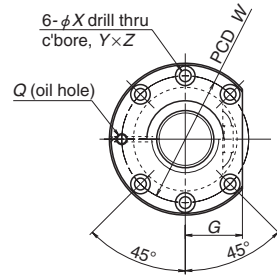

Circular shape II

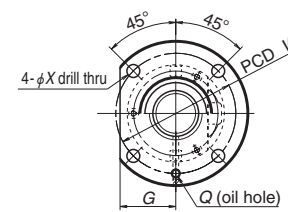

LDFT

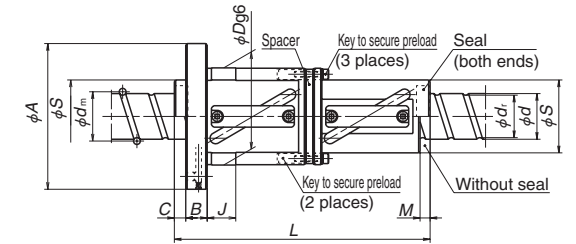

Unit: mm

Model No.	Preload system	Shaft dia. d	Lead l	Ball dia. D _w	Ball circle dia. d _m	Root dia. d _r	Effective turns of balls Turns × Circuits	Basic load rating (N)		Axial rigidity K (N/μm)	Nut entire length L	
								Dynamic C ₀	Static C _{0s}			
LPFT 2516-2.5	P	25	16	4.762	26.25	21.3	2.5×1	9 900	16 400	210	84	
LPFT 2516-3	P						1.5×2	11 600	19 100	247	100	
LSFT 2516-2.5	Clearance						2.5×1	15 700	32 800	250	84	
LDFT 2516-2.5	D						2.5×1	15 700	32 800	490	152	
LSFT 2516-3	Clearance						1.5×2	18 400	38 200	295	100	
LDFT 2516-3	D						1.5×2	18 400	38 200	577	181	
* LPFT 2520-2.5	P		20	16	4.762	26.25	21.3	2.5×1	9 900	16 400	210	96
LPFT 2520-3	P							1.5×2	11 600	19 100	247	116
LSFT 2520-2.5	Clearance							2.5×1	15 700	32 800	250	96
LDFT 2520-2.5	D							2.5×1	15 700	32 800	490	177
LSFT 2520-3	Clearance							1.5×2	18 400	38 200	295	116
LDFT 2520-3	D							1.5×2	18 400	38 200	577	217
* LPFT 2525-1.5	P	25	5	3.175	28.5	25.2	2.5×1	6 380	9 540	127	90	
LDFT 2525-1.5	D						1.5×1	10 100	19 100	308	166	
LSFT 2525-1.5	Clearance						2.5×2	10 100	19 100	157	90	
SFT 2805-2.5	Clearance						2.5×1	9 600	24 400	252	41	
ZFT 2805-5	Z						2.5×1	9 600	24 400	495	56	
PFT 2805-5	P						2.5×2	11 000	24 400	410	56	
SFT 2805-5	Clearance	2.5×2	17 400	48 800	487	56						
* ZFT 2805-10	Z	2.5×2	17 400	48 800	959	86						

- Notes: 1. Nut flange for shaft diameter 20 mm or larger comes in circular shape I and circular shape II. Select a flange that is suitable for the space available for nut installation.
 2. If there is no seal for PFT, ZFT, and SFT, the nut length "L" is shortened by dimension "M".
 3. If there is no seal for LSFT and LDFT of shaft diameter 25 mm or larger, the nut length "L" is shortened by dimension "M" and "C".
 4. The right turn screw is standard. "L" is added to the end of the model code for the left turn screw.

Nut diameter		Ball nut dimensions													
D	S	Flanged diameter A	Flanged width B	Notched flange G	Tube projecting type			Seal dimension M	C	Diameter g6 J	Bolt hole dimension			PCD W	Oil hole Q
					U	V	R				X	Y	Z		
44	—	71	12	23	31	35	12	6	8	18	6.6	—	—	57	M6×1
44	—	71		23	31	35	12							57	
44	—	71		23	31	35	12							57	
62	44	89		34	—	—	—							75	
44	—	71		23	31	35	12							57	
62	44	89		34	—	—	—							75	
44	—	71	12	23	31	35	12	7	8	18	6.6	—	—	57	M6×1
44	—	71		23	31	35	12							57	
44	—	71		23	31	35	12							57	
62	44	89		34	—	—	—							75	
44	—	71		23	31	35	12							57	
62	44	89		34	—	—	—							75	
44	—	71	12	23	32	34	12	10	10	18	6.6	—	—	57	M6×1
62	44	89		34	—	—	—							75	
44	—	71		23	32	34	12							57	
62	44	89		34	—	—	—							75	
44	—	71		23	32	34	12							57	
44	—	71		23	32	34	12							57	
55	—	85	12	31	—	—	—	3	—	—	6.6	11	6.5	69	M6×1

5. The axial rigidity K in the table above is a theoretical value obtained from the elastic deformation between screw groove and ball when the axial load is 30% of the basic dynamic load rating (C₀) with non-preload, 10% with D-preload, and 5% with P-preload. Refer to "Technical Description" (page B37) if the axial load and preload differ from the conditions above, or when the deformation of the ball nut body must be considered.
 6. For PFT and LPFT, the basic load ratings differ from the other models as the spacer balls are installed.
 7. The models marked with * (asterisk) are available in the FA or SA type standard ball screws with finished shaft end.
 8. Preload system: P, Oversize ball preload; Z, Offset preload; D, Double nut preload (See page B5.)

Return tube type

View X-X

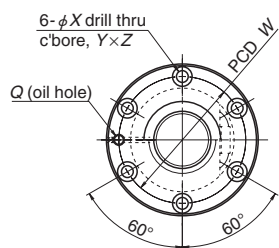

Circular shape I

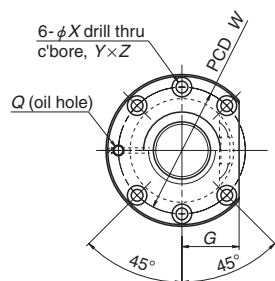

Circular shape II

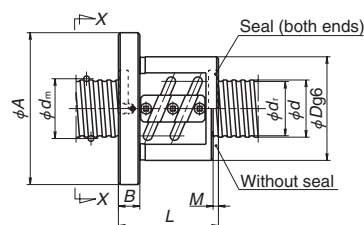

PFT, ZFT, SFT

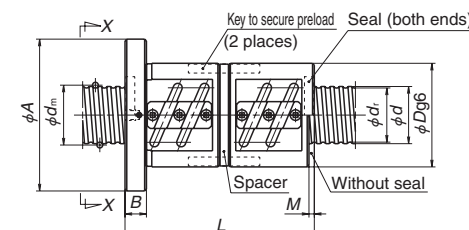

DFT

Unit: mm

Model No.	Preload system	Shaft dia. <i>d</i>	Lead <i>l</i>	Ball dia. <i>D_w</i>	Ball circle dia. <i>d_m</i>	Root dia. <i>d_r</i>	Effective turns of balls Turns × Circuits	Basic load rating (N)		Axial rigidity <i>K</i> (N/μm)
								Dynamic <i>C_d</i>	Static <i>C_{0s}</i>	
PFT 2806-3	P	28	6	3.175	28.5	25.2	1.5×2	7 080	14 600	252
SFT 2806-2.5	Clearance						2.5×1	9 600	24 400	252
ZFT 2806-5	Z						2.5×1	9 600	24 400	495
* PFT 2806-5	P						2.5×2	11 000	24 400	410
SFT 2806-3	Clearance						1.5×2	11 200	29 300	300
DFT 2806-3	D						1.5×2	11 200	29 300	590
SFT 2806-5	Clearance		2.5×2	17 400	48 800	487				
* ZFT 2806-10	Z		2.5×2	17 400	48 800	959				
PFT 2810-2.5	P		10	4.762	28.5	23.5	2.5×1	10 500	18 000	220
ZFT 2810-3	Z						1.5×1	10 800	21 500	320
PFT 2810-3	P						1.5×2	12 300	21 500	265
SFT 2810-2.5	Clearance						2.5×1	16 700	36 100	265
DFT 2810-2.5	D	2.5×1					16 700	36 100	522	
SFT 2810-3	Clearance	1.5×2					19 500	43 000	314	
DFT 2810-3	D	1.5×2	19 500	43 000	618					
SFT 3204-2.5	Clearance	4	2.381	32.3	29.8	2.5×1	5 800	17 500	234	
ZFT 3204-5	Z					2.5×1	5 800	17 500	461	
PFT 3204-5	P					2.5×2	6 630	17 500	382	
SFT 3204-5	Clearance					2.5×2	10 500	35 100	454	
ZFT 3204-10	Z					2.5×2	10 500	35 100	892	
* PFT 3205-3	P					1.5×2	7 490	16 800	281	
SFT 3205-2.5	Clearance	2.5×1	10 200	28 000	281					
ZFT 3205-5	Z	2.5×1	10 200	28 000	552					
* PFT 3205-5	P	2.5×2	11 600	28 000	455					
SFT 3205-3	Clearance	1.5×2	11 900	33 600	333					
DFT 3205-3	D	1.5×2	11 900	33 600	655					
PFT 3205-7.5	P	2.5×3	16 500	42 100	672					
SFT 3205-5	Clearance	2.5×2	18 500	56 100	543					
* ZFT 3205-10	Z	2.5×2	18 500	56 100	1 070					
SFT 3205-7.5	Clearance	2.5×3	26 200	84 100	799					
DFT 3205-7.5	D	2.5×3	26 200	84 100	1 572					

Notes: 1. Nut flange for shaft diameter 20 mm or larger comes in circular shape I and circular shape II. Select a flange that is suitable for the space available for nut installation.

2. If there is no seal for PFT, ZFT, SFT, and DFT, the nut length "L" is shortened by dimension "M".

3. The right turn screw is standard. "L" is added to the end of the model code for the left turn screw.

Ball nut dimensions										
Nut entire length <i>L</i>	Nut diameter <i>D</i>	Flanged diameter <i>A</i>	Flanged width <i>B</i>	Notched flange <i>G</i>	Seal dimension <i>M</i>	Bolt hole dimension			Bolt hole PCD <i>W</i>	Oil hole <i>Q</i>
						<i>X</i>	<i>Y</i>	<i>Z</i>		
57	55	85	12	31	3	6.6	11	6.5	69	M6×1
45										
63										
63										
57										
111										
63										
99										
68										
82										
82										
68										
128										
82										
152										
37										
49										
49										
49										
73										
53										
41										
56										
56										
53										
103										
71										
56										
86										
71										
136										

4. The axial rigidity *K* in the table above is a theoretical value obtained from the elastic deformation between screw groove and ball when the axial load is 30% of the basic dynamic load rating (*C_d*) with non-preload, 10% with D-preload, and 5% with P-preload. Refer to "Technical Description" (page B37) if the axial load and preload differ from the conditions above, or when the deformation of the ball nut body must be considered.

5. For PFT, the basic load ratings differ from the other models as the spacer balls are installed.

6. The models marked with * (asterisk) are available in the SA type standard ball screws with finished shaft end.

7. Preload system: P, Oversize ball preload; Z, Offset preload; D, Double nut preload (See page B5.)

Return tube type

View X-X

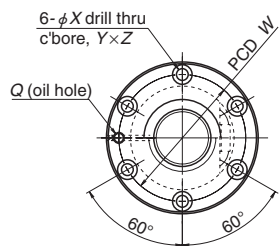

Circular shape I

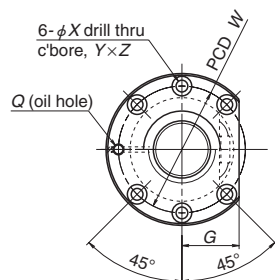

Circular shape II

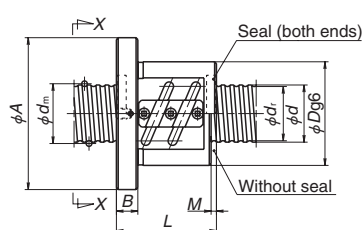

PFT, ZFT, SFT

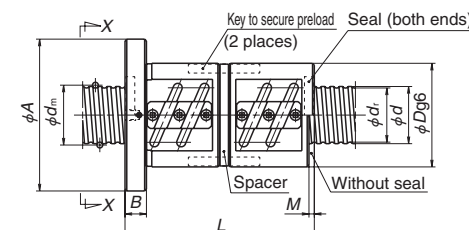

DFT

Unit: mm

Model No.	Preload system	Shaft dia. <i>d</i>	Lead <i>l</i>	Ball dia. <i>D_w</i>	Ball circle dia. <i>d_m</i>	Root dia. <i>d_r</i>	Effective turns of balls Turns × Circuits	Basic load rating (N)		Axial rigidity <i>K</i> (N/μm)					
								Dynamic <i>C_d</i>	Static <i>C_{0a}</i>						
PFT 3206-3	P	6	3.969	32.5	28.4	28.4	1.5x2	10 000	20 600	285					
SFT 3206-2.5	Clearance						2.5x1	13 600	34 700	287					
ZFT 3206-5	Z						2.5x1	13 600	34 700	563					
PFT 3206-5	P						2.5x2	15 500	34 700	468					
SFT 3206-3	Clearance						1.5x2	15 900	41 200	339					
DFT 3206-3	D						1.5x2	15 900	41 200	666					
SFT 3206-5	Clearance						2.5x2	24 700	69 400	555					
ZFT 3206-10	Z						2.5x2	24 700	69 400	1 090					
PFT 3208-3	P						8	4.762	32.5	27.5	27.5	1.5x2	12 900	24 800	294
SFT 3208-2.5	Clearance											2.5x1	17 500	41 000	292
ZFT 3208-5	Z	2.5x1	17 500	41 000	573										
PFT 3208-5	P	2.5x2	20 000	41 000	470										
SFT 3208-3	Clearance	1.5x2	20 400	49 500	349										
ZFT 3208-6	Z	1.5x2	20 400	49 500	686										
SFT 3208-5	Clearance	2.5x2	31 700	82 000	565										
DFT 3208-5	D	2.5x2	31 700	82 000	1 102										
ZFT 3208-10	Z	2.5x2	31 700	82 000	1 102										
PFT 3210-2.5	P	10	6.35	33.0	26.4	26.4						2.5x1	16 100	27 000	255
ZFT 3210-3	Z						1.5x1	16 400	32 400	365					
PFT 3210-3	P						1.5x2	18 800	32 400	303					
SFT 3210-2.5	Clearance						2.5x1	25 500	54 000	302					
ZFT 3210-5	Z						2.5x1	25 500	54 000	594					
PFT 3210-5	P						2.5x2	29 200	54 000	494					
SFT 3210-3	Clearance						1.5x2	29 900	64 800	360					
DFT 3210-3	D						1.5x2	29 900	64 800	707					
SFT 3210-3.5	Clearance						3.5x1	34 100	77 000	422					
DFT 3210-3.5	D						3.5x1	34 100	77 000	829					
SFT 3210-5	Clearance	2.5x2	46 300	108 000	585										
DFT 3210-5	D	2.5x2	46 300	108 000	1 156										
ZFT 3210-10	Z	2.5x2	46 300	108 000	1 156										
PFT 3212-2.5	P	12	6.35	33.0	26.4	26.4	2.5x1	16 100	27 000	255					
ZFT 3212-3	Z						1.5x1	16 400	32 400	365					
PFT 3212-3	P						1.5x2	18 800	32 400	303					
SFT 3212-2.5	Clearance						2.5x1	25 500	54 000	302					
DFT 3212-2.5	D						2.5x1	25 500	54 000	603					
SFT 3212-3	Clearance						1.5x2	29 900	64 800	360					
DFT 3212-3	D						1.5x2	29 900	64 800	707					

Notes: 1. Nut flange for shaft diameter 20 mm or larger comes in circular shape I and circular shape II. Select a flange that is suitable for the space available for nut installation.

2. If there is no seal for PFT, ZFT, SFT, and DFT, the nut length "L" is shortened by dimension "M".

3. The right turn screw is standard. "L" is added to the end of the model code for the left turn screw.

Nut entire length <i>L</i>	Nut diameter <i>D</i>	Flanged diameter <i>A</i>	Flanged width <i>B</i>	Notched flange <i>G</i>	Seal dimension <i>M</i>	Bolt hole dimension			Bolt hole PCD <i>W</i>	Oil hole <i>Q</i>
						<i>X</i>	<i>Y</i>	<i>Z</i>		
57	62	89	12	34	3	6.6	11	6.5	75	M6x1
45										
63										
63										
57										
111										
63										
99										
71										
58										
82										
82										
71										
111										
82										
154										
130										
70										
87										
87										
70										
100										
100										
87										
167										
80										
150										
100										
190										
160										
81										
97										
97										
81										
153										
97										
181										

4. The axial rigidity *K* in the table above is a theoretical value obtained from the elastic deformation between screw groove and ball when the axial load is 30% of the basic dynamic load rating (*C_d*) with non-preload, 10% with D-preload, and 5% with P-preload. Refer to "Technical Description" (page B37) if the axial load and preload differ from the conditions above, or when the deformation of the ball nut body must be considered.

5. For PFT, the basic load ratings differ from the other models as the spacer balls are installed.

6. The models marked with * (asterisk) are available in the SA type standard ball screws with finished shaft end.

7. Preload system: P, Oversize ball preload; Z, Offset preload; D, Double nut preload (See page B5.)

Return tube type

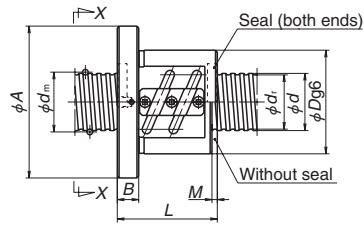

PFT, ZFT, SFT

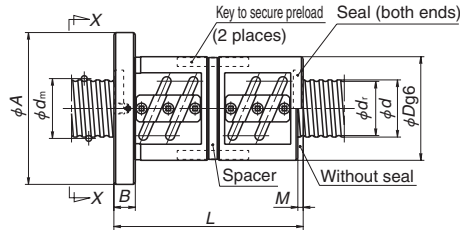

DFT

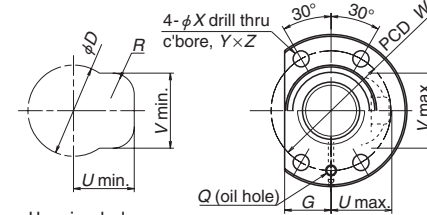

Housing hole and its clearance

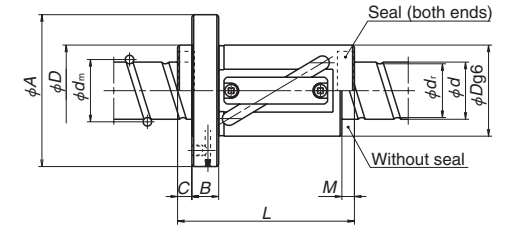

LPFT, LSFT

View X-X

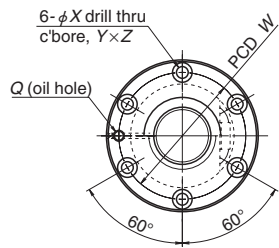

Circular shape I

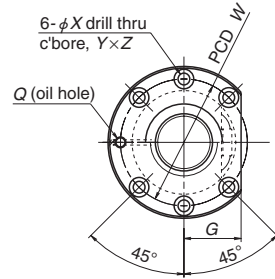

Circular shape II

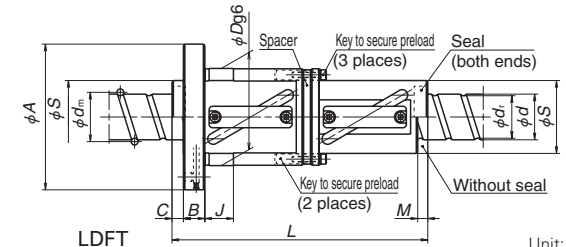
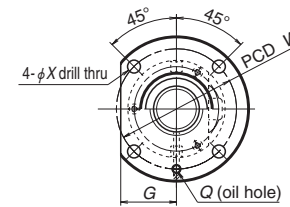

LDFT

Unit: mm

Model No.	Preload system	Shaft dia. d	Lead l	Ball dia. Dw	Ball circle dia. dm	Root dia. dr	Effective turns x Circuits	Basic load rating (N)		Axial rigidity K (N/μm)	Nut entire length L
								Dynamic Cs	Static Csw		
LPFT 3220-2.5	P	32	20	4.762	33.25	28.3	2.5x1	11 300	20 900	251	99
LPFT 3220-3	P						1.5x2	13 200	24 800	297	119
LSFT 3220-2.5	Clearance D						2.5x1	17 900	41 800	300	99
LDFT 3220-2.5	D						2.5x1	17 900	41 800	604	179
LSFT 3220-3	Clearance D						1.5x2	21 000	49 600	360	119
LDFT 3220-3	D						1.5x2	21 000	49 600	708	219
* LPFT 3225-2.5	P		25	4.762	33.25	28.3	2.5x1	11 300	20 900	251	117
LPFT 3225-3	P						1.5x2	13 200	24 800	297	142
LSFT 3225-2.5	Clearance D						2.5x1	17 900	41 800	300	117
LDFT 3225-2.5	D						2.5x1	17 900	41 800	604	218
LSFT 3225-3	Clearance D						1.5x2	21 000	49 600	360	142
LDFT 3225-3	D						1.5x2	21 000	49 600	708	268
* LPFT 3232-1.5	P	32	4.762	33.25	28.3	1.5x1	7 280	12 400	161	109	
LSFT 3232-1.5	Clearance D					1.5x1	11 500	24 800	190	109	
LDFT 3232-1.5	D					1.5x1	11 500	24 800	376	205	
ZFT 3605-5	Z					36	5	3.175	36.5	33.2	2.5x1
PFT 3605-5	P	2.5x2	12 200	31 700	504						59
PFT 3605-7.5	P	2.5x3	17 300	47 500	740						74
SFT 3605-5	Clearance Z	2.5x2	19 400	63 300	597						59
ZFT 3605-10	Z	2.5x2	19 400	63 300	1 170						89
SFT 3605-7.5	Clearance Z	2.5x3	27 500	95 000	878						74
DFT 3605-7.5	D	2.5x3	27 500	95 000	1 730						139

- Notes: 1. Nut flange for shaft diameter 20 mm or larger comes in circular shape I and circular shape II. Select a flange that is suitable for the space available for nut installation.
 2. If there is no seal for PFT, ZFT, SFT, and DFT the nut length "L" is shortened by dimension "M".
 3. If there is no seal for LSFT and LDFT of shaft diameter 25 mm or larger, the nut length "L" is shortened by dimension "M" and "C".
 4. The right turn screw is standard. "L" is added to the end of the model code for the left turn screw.

Ball nut dimensions															
Nut diameter		Flanged diameter A	Flanged width B	Notched flange G	Tube projecting type			Seal dimension M	Seal dimension C	Diameter g6 J	Bolt hole dimension			Bolt hole PCD W	Oil hole Q
D	S				U	V	R				X	Y	Z		
51	—	85	15	26	34	42	12	7	8	20	9	—	—	67	
51	—	85		26	34	42	12							67	
68	51	102		39	—	—	—							84	
51	—	85		26	34	42	12							67	
68	51	102		39	—	—	—							84	
51	—	85		26	34	42	12							67	
51	—	85	15	26	34	42	12	10	10	20	9	—	—	67	
51	—	85		26	34	42	12							67	
68	51	102		39	—	—	—							84	
51	—	85		26	34	42	12							67	
68	51	102		39	—	—	—							84	
51	—	85		26	34	42	12							67	
51	—	85	15	26	34	42	12	13	12	20	9	—	—	67	
51	—	85		26	34	42	12							67	
68	51	102		39	—	—	—							84	
65	—	100	15	38	—	—	—	3	—	—	9	14	8.5	82	M6x1

5. The axial rigidity K in the table above is a theoretical value obtained from the elastic deformation between screw groove and ball when the axial load is 30% of the basic dynamic load rating (Cs) with non-preload, 10% with D-preload, and 5% with P-preload. Refer to "Technical Description" (page B37) if the axial load and preload differ from the conditions above, or when the deformation of the ball nut body must be considered.
 6. For PFT and LPFT, the basic load ratings differ from the other models as the spacer balls are installed.
 7. The models marked with * (asterisk) are available in the FA type standard ball screws with finished shaft end.
 8. Preload system: P, Oversize ball preload; Z, Offset preload; D, Double nut preload (See page B5).

Return tube type

View X-X

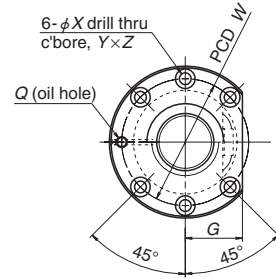
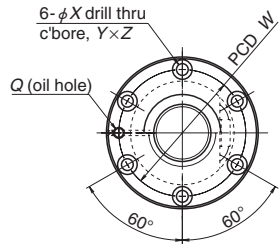

Circular shape I

Circular shape II

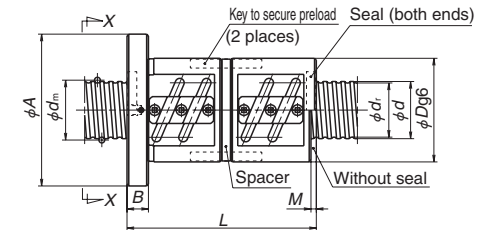
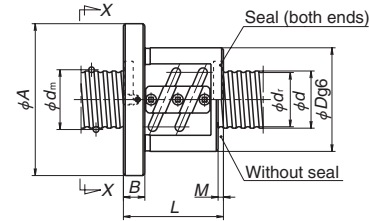

PFT, ZFT, SFT

DFT

Unit: mm

Model No.	Preload system	Shaft dia. <i>d</i>	Lead <i>l</i>	Ball dia. <i>D_w</i>	Ball circle dia. <i>d_m</i>	Root dia. <i>d_r</i>	Effective turns of balls Turns \times Circuits	Basic load rating (N)		Axial rigidity <i>K</i> (N/ μ m)	
								Dynamic <i>C_d</i>	Static <i>C_{0a}</i>		
ZFT 3606-5	Z	36	6	3.969	36.5	32.4	2.5 \times 1	14 600	39 300	625	
PFT 3606-5	P						2.5 \times 2	16 700	39 300	518	
PFT 3606-7.5	P						2.5 \times 3	23 700	58 900	763	
SFT 3606-5	Clearance						2.5 \times 2	26 500	78 500	615	
ZFT 3606-10	Z						2.5 \times 2	26 500	78 500	1 210	
SFT 3606-7.5	Clearance						2.5 \times 3	37 600	118 000	905	
DFT 3606-7.5	D		2.5 \times 3	37 600	118 000	1 780					
PFT 3610-2.5	P		36	10	6.35	37.0	30.4	2.5 \times 1	17 100	30 600	278
ZFT 3610-3	Z							1.5 \times 1	17 500	36 800	404
PFT 3610-3	P							1.5 \times 2	20 000	36 800	327
SFT 3610-2.5	Clearance							2.5 \times 1	27 200	61 300	334
* ZFT 3610-5	Z							2.5 \times 1	27 200	61 300	657
PFT 3610-5	P	2.5 \times 2						31 100	61 300	537	
SFT 3610-3	Clearance	1.5 \times 2		31 800	73 500	397					
DFT 3610-3	D	1.5 \times 2		31 800	73 500	781					
PFT 3610-7.5	P	2.5 \times 3		43 700	96 000	782					
SFT 3610-5	Clearance	2.5 \times 2		49 300	123 000	647					
DFT 3610-5	D	2.5 \times 2		49 300	123 000	1 259					
ZFT 3610-10	Z	2.5 \times 2		49 300	123 000	1 259					
SFT 3610-7.5	Clearance	2.5 \times 3	69 900	184 000	945						
PFT 4005-3	P	40	5	3.175	40.5	37.2	1.5 \times 2	8 210	21 200	337	
SFT 4005-2.5	Clearance						2.5 \times 1	11 100	35 300	336	
ZFT 4005-5	Z						2.5 \times 1	11 100	35 300	661	
PFT 4005-5	P						2.5 \times 2	12 700	35 300	548	
SFT 4005-3	Clearance						1.5 \times 2	13 000	42 400	399	
DFT 4005-3	D						1.5 \times 2	13 000	42 400	785	
PFT 4005-7.5	P		2.5 \times 3	18 100	53 000	806					
SFT 4005-5	Clearance		2.5 \times 2	20 200	70 600	649					
* ZFT 4005-10	Z		2.5 \times 2	20 200	70 600	1 280					
SFT 4005-7.5	Clearance		2.5 \times 3	28 700	106 000	956					
DFT 4005-7.5	D		2.5 \times 3	28 700	106 000	1 870					
ZFT 4006-5	Z		40	6	3.969	40.5	36.4	2.5 \times 1	15 200	43 800	679
PFT 4006-5	P	2.5 \times 2						17 400	43 800	564	
SFT 4006-3	Clearance	1.5 \times 2						17 800	52 600	411	
DFT 4006-3	D	1.5 \times 2						17 800	52 600	807	
PFT 4006-7.5	P	2.5 \times 3						24 600	65 700	827	
SFT 4006-5	Clearance	2.5 \times 2						27 600	87 600	668	
ZFT 4006-10	Z	2.5 \times 2		27 600	87 600	1 320					
SFT 4006-7.5	Clearance	2.5 \times 3		39 100	131 000	984					
DFT 4006-7.5	D	2.5 \times 3		39 100	131 000	1 940					

Notes: 1. Nut flange for shaft diameter 20 mm or larger comes in circular shape I and circular shape II. Select a flange that is suitable for the space available for nut installation.
2. If there is no seal for PFT, ZFT, SFT, and DFT, the nut length "L" is shortened by dimension "M".
3. The right turn screw is standard. "L" is added to the end of the model code for the left turn screw.

Nut entire length <i>L</i>	Nut diameter <i>D</i>	Flanged diameter <i>A</i>	Flanged width <i>B</i>	Notched flange <i>G</i>	Seal dimension <i>M</i>	Ball nut dimensions			Bolt hole PCD <i>W</i>	Oil hole <i>Q</i>
						Bolt hole dimension				
						<i>X</i>	<i>Y</i>	<i>Z</i>		
66	65	100	15	38	3	9	14	8.5	82	M6 \times 1
66										
84										
66										
102										
84										
162										
73	75	120	18	45	7	11	17.5	11	98	M6 \times 1
90										
90										
73										
103										
103										
90										
170										
133										
103										
193										
163										
133										
56	67	101	15	39	3	9	14	8.5	83	Rc1/8
44										
59										
59										
56										
106										
74										
59	70	104	15	40	3	9	14	8.5	86	Rc1/8
114										
84										
66										
102										
84										
162										

4. The axial rigidity *K* in the table above is a theoretical value obtained from the elastic deformation between screw groove and ball when the axial load is 30% of the basic dynamic load rating (*C_d*) with non-preload, 10% with D-preload, and 5% with P-preload. Refer to "Technical Description" (page B37) if the axial load and preload differ from the conditions above, or when the deformation of the ball nut body must be considered.
5. For PFT, the basic load ratings differ from the other models as the spacer balls are installed.
6. The models marked with * (asterisk) are available in the SA type standard ball screws with finished shaft end.
7. Preload system: P, Oversize ball preload; Z, Offset preload; D, Double nut preload (See page B5.)

Return tube type

View X-X

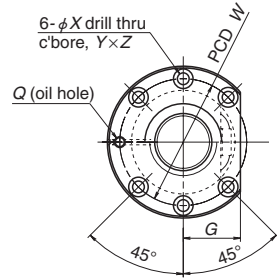
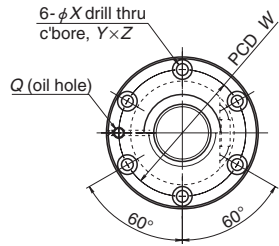

Circular shape I

Circular shape II

Model No.	Preload system	Shaft dia. <i>d</i>	Lead <i>l</i>	Ball dia. <i>D_w</i>	Ball circle dia. <i>d_m</i>	Root dia. <i>d_t</i>	Effective turns of balls Turns × Circuits	Basic load rating (N)		Axial rigidity <i>K</i> (N/μm)			
								Dynamic <i>C₀</i>	Static <i>C_{0s}</i>				
PFT 4008-3	P	40	8	4.762	40.5	35.5	1.5×2	14 200	31 300	352			
SFT 4008-2.5	Clearance						2.5×1	19 200	51 600	349			
ZFT 4008-5	Z						2.5×1	19 200	51 600	687			
PFT 4008-5	P						2.5×2	22 000	51 600	570			
SFT 4008-3	Clearance						1.5×2	22 500	62 600	418			
DFT 4008-3	D						1.5×2	22 500	62 600	822			
SFT 4008-5	Clearance						2.5×2	34 900	103 000	675			
ZFT 4008-10	Z						2.5×2	34 900	103 000	1 330			
PFT 4010-2.5	P						2.5×1	18 000	34 300	307			
PFT 4010-3	P						1.5×2	21 100	41 100	366			
SFT 4010-2.5	Clearance						2.5×1	28 600	68 600	365			
ZFT 4010-5	Z						2.5×1	28 600	68 600	717			
PFT 4010-5	P	2.5×2	32 800	68 600	595								
SFT 4010-3	Clearance	1.5×2	33 500	82 300	434								
ZFT 4010-6	Z	1.5×2	33 500	82 300	854								
ZFT 4010-7	Z	3.5×1	38 300	96 000	988								
SFT 4010-3.5	Clearance	3.5×1	38 300	96 000	503								
PFT 4010-7	P	3.5×2	43 700	96 000	813								
SFT 4010-5	Clearance	2.5×2	52 000	137 000	706								
DFT 4010-5	D	2.5×2	52 000	137 000	1 376								
ZFT 4010-10	Z	2.5×2	52 000	137 000	1 376								
SFT 4010-7	Clearance	3.5×2	69 400	192 000	976								
PFT 4012-2.5	P	12	7.144	41.5	34.1	2.5×1	21 200	38 800	310				
SFT 4012-2.5	Clearance					2.5×1	33 600	77 500	373				
ZFT 4012-5	Z					2.5×1	33 600	77 500	733				
PFT 4012-5	P					2.5×2	38 400	77 500	600				
PFT 4012-7.5	P					2.5×3	54 400	116 000	872				
SFT 4012-5	Clearance					2.5×2	61 000	155 000	722				
DFT 4012-5	D					2.5×2	61 000	155 000	1 404				
ZFT 4012-10	Z					2.5×2	61 000	155 000	1 404				
SFT 4012-7.5	Clearance					2.5×3	86 400	233 000	1 054				
ZFT 4016-3	Z					16	7.144	41.5	34.1	1.5×1	21 700	46 500	451
SFT 4016-2.5	Clearance									2.5×1	33 600	77 500	373
DFT 4016-2.5	D									2.5×1	33 600	77 500	733
SFT 4016-3	Clearance	1.5×2	39 300	93 100	440								
DFT 4016-3	D	1.5×2	39 300	93 100	872								

Notes: 1. Nut flange for shaft diameter 20 mm or larger comes in circular shape I and circular shape II. Select a flange that is suitable for the space available for nut installation.
 2. If there is no seal for PFT, ZFT, SFT, and DFT, the nut length "L" is shortened by dimension "M".
 3. The right turn screw is standard. "L" is added to the end of the model code for the left turn screw.

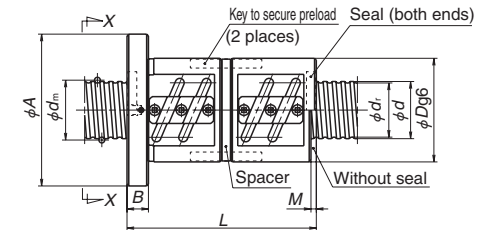
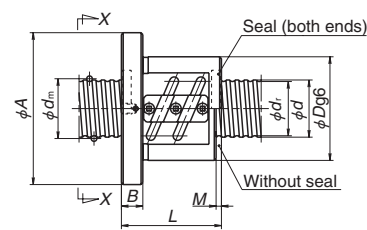

PFT, ZFT, SFT

DFT

Unit: mm

Nut entire length <i>L</i>	Nut diameter <i>D</i>	Flanged diameter <i>A</i>	Flanged width <i>B</i>	Notched flange <i>G</i>	Seal dimension <i>M</i>	Ball nut dimensions			Bolt hole PCD <i>W</i>	Oil hole <i>Q</i>										
						Bolt hole dimension														
						<i>X</i>	<i>Y</i>	<i>Z</i>												
71	74	108	15	41	5	9	14	8.5	90	Rc1/8										
58																				
82																				
82																				
71																				
135																				
82																				
130																				
73																				
90																				
73																				
103																				
90																				
140	82	124	18	47	7	11	17.5	11	102	Rc1/8										
123																				
83																				
123																				
103																				
193																				
163																				
123																				
81																				
81																				
117																				
117																				
153	86	128	18	48	9	11	17.5	11	106	Rc1/8										
117																				
117																				
225																				
189																				
153																				
118																				
102																				
182											86	128	22	48	14	11	17.5	11	106	Rc1/8
118																				
214																				

4. The axial rigidity *K* in the table above is a theoretical value obtained from the elastic deformation between screw groove and ball when the axial load is 30% of the basic dynamic load rating (*C₀*) with non-preload, 10% with D-preload, and 5% with P-preload. Refer to "Technical Description" (page B37) if the axial load and preload differ from the conditions above, or when the deformation of the ball nut body must be considered.
 5. For PFT, the basic load ratings differ from the other models as the spacer balls are installed.
 6. The models marked with * (asterisk) are available in the SA type standard ball screws with finished shaft end.
 7. Preload system: P, Oversize ball preload; Z, Offset preload; D, Double nut preload (See page B5.)

Return tube type

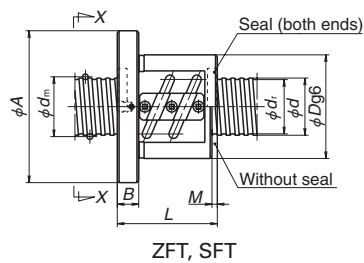

ZFT, SFT

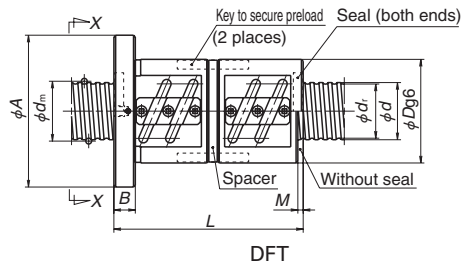

DFT

View X-X

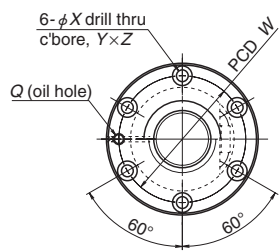

Circular shape I

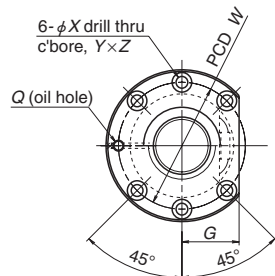

Circular shape II

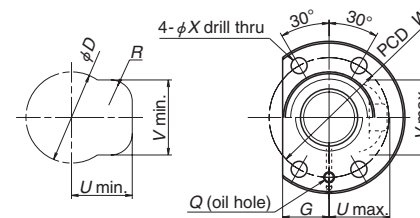

Housing hole and its clearance

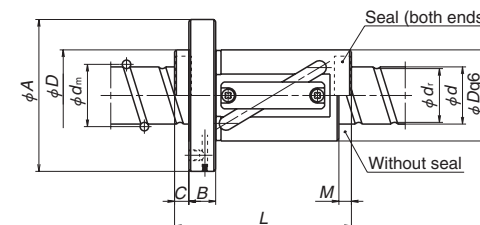

LPFT, LSFT

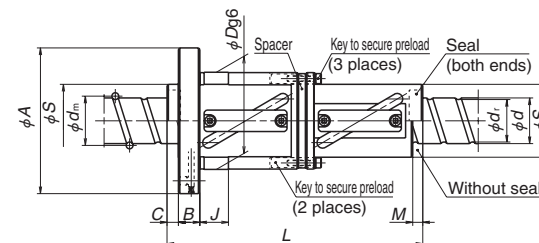
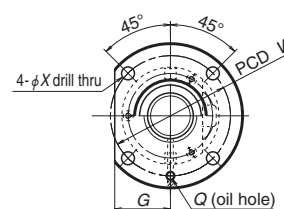

LDFT

Unit: mm

Model No.	Preload system	Shaft dia. d	Lead l	Ball dia. D_w	Ball circle dia. d_m	Root dia. d_r	Effective turns of balls \times Circuits	Basic load rating (N)		Axial rigidity K (N/ μ m)	Nut entire length L										
								Dynamic C_d	Static C_{0d}												
LPFT 4025-2.5	P	40	25	6.35	41.75	35.1	2.5×1	18 000	35 000	315	123										
LPFT 4025-3	P						1.5×2	21 000	41 200	347	148										
LSFT 4025-2.5	Clearance D						2.5×1	28 500	70 000	375	123										
LDFT 4025-2.5	Clearance D						2.5×1	28 500	70 000	375	223										
LSFT 4025-3	Clearance D						1.5×2	33 400	82 400	444	148										
LDFT 4025-3	Clearance D						1.5×2	33 400	82 400	873	273										
LPFT 4032-2.5	P						32	6.35	41.75	35.1	2.5×1	18 000	35 000	315	146						
LSFT 4032-2.5	Clearance D											28 500	70 000	375	146						
LDFT 4032-2.5	Clearance D											28 500	70 000	737	274						
LPFT 4040-1.5	P											40	6.35	41.75	35.1	1.5×1	11 600	20 600	199	133	
LSFT 4040-1.5	Clearance D	18 400	41 200	237	133																
LDFT 4040-1.5	Clearance D	18 400	41 200	465	253																
ZFT 4510-5	Z	45	10	6.35	46.0	39.4											2.5×1	29 900	77 300	784	103
PFT 4510-7	P																3.5×2	45 600	109 000	887	123
PFT 4510-7.5	P																2.5×3	48 400	116 000	950	133
SFT 4510-5	Clearance D																2.5×2	54 200	155 000	772	103
DFT 4510-5	Clearance D						2.5×2	54 200	155 000	1 520	193										
SFT 4510-7	Clearance D						3.5×2	72 400	218 000	1 064	123										
SFT 4510-7.5	Clearance D						2.5×3	76 800	232 000	1 140	133										
DFT 4510-7.5	Clearance D						2.5×3	76 800	232 000	2 230	253										
SFT 4512-2.5	Clearance D						2.5×1	35 400	88 500	412	83										
ZFT 4512-5	Z						12	7.144	46.5	39.1	2.5×1	35 400	88 500	811	119						
SFT 4512-5	Clearance D	2.5×2	64 200	177 000	798	119															
DFT 4512-5	Clearance D	2.5×2	64 200	177 000	1 570	227															

- Notes: 1. Nut flange for shaft diameter 20 mm or larger comes in circular shape I and circular shape II. Select a flange that is suitable for the space available for nut installation.
 2. If there is no seal for ZFT, SFT, and DFT the nut length "L" is shortened by dimension "M".
 3. If there is no seal for LSFT and LDFT of shaft diameter 25 mm or larger, the nut length "L" is shortened by dimension "M" and "C".
 4. The right turn screw is standard. "L" is added to the end of the model code for the left turn screw.

Nut diameter		Ball nut dimensions										Oil hole								
D	S	Flanged diameter A	Flanged width B	Notched flange G	Tube projecting type			Seal dimension		Bolt hole dimension										
					U	V	R	M	C	Diameter g6 J	X	Y	Z	Bolt hole PCD W						
64	—	106	18	33	42	52	15	10	10	—	11	—	—	84						
64	—	106			42	52	15			84										
64	—	106			42	52	15			84										
84	64	126			48	—	—			104										
64	—	106			33	42	52			15				84						
84	64	126			48	—	—			104										
64	—	106			33	42	52			15				13	12	—	11	—	—	84
64	—	106			33	42	52			15				16	14	—	11	—	—	84
64	—	106			33	42	52			15				16	14	—	11	—	—	84
84	64	126			48	—	—			104										
88	—	132	18	50	—	—	—	7	—	—	11	17.5	11	110	Rc1/8					
90	—	132	18	50	—	—	—	8	—	—	11	17.5	11	110	Rc1/8					

5. The axial rigidity K in the table above is a theoretical value obtained from the elastic deformation between screw groove and ball when the axial load is 30% of the basic dynamic load rating (C_d) with non-preload, 10% with D-preload, and 5% with P-preload. Refer to "Technical Description" (page B37) if the axial load and preload differ from the conditions above, or when the deformation of the ball nut body must be considered.
 6. For LPFT, the basic load ratings differ from the other models as the spacer balls are installed.
 7. Preload system: P, Oversize ball preload; Z, Offset preload; D, Double nut preload (See page B5.)

Return tube type

View X-X

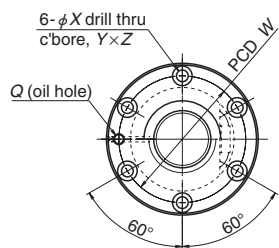

Circular shape I

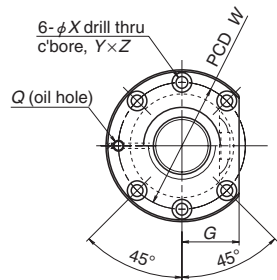

Circular shape II

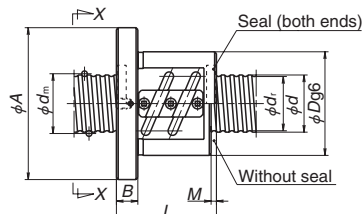

ZFT, SFT

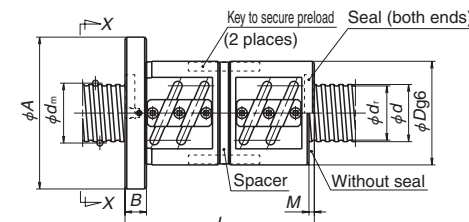

DFT

Unit: mm

Model No.	Preload system	Shaft dia. <i>d</i>	Lead <i>l</i>	Ball dia. <i>D_w</i>	Ball circle dia. <i>d_m</i>	Root dia. <i>d_i</i>	Effective turns of balls Turns × Circuits	Basic load rating (N)		Axial rigidity <i>K</i> (N/μm)			
								Dynamic <i>C_d</i>	Static <i>C_{0a}</i>				
SFT 5005-3	Clearance	50	5	3.175	50.5	47.2	1.5x2	14 200	52 500	472			
ZFT 5005-6	Z						1.5x2	14 200	52 500	930			
SFT 5005-4.5	Clearance						1.5x3	20 200	78 800	696			
ZFT 5005-9	Z						1.5x3	20 200	78 800	1 360			
SFT 5006-3	Clearance						1.5x2	19 500	65 100	486			
DFT 5006-3	D						1.5x2	19 500	65 100	956			
PFT 5006-7.5	P		6	3.969	50.5	46.4	2.5x3	27 000	81 900	988			
SFT 5006-5	Clearance						2.5x2	30 300	109 000	794			
ZFT 5006-10	Z						2.5x2	30 300	109 000	1 562			
SFT 5006-7.5	Clearance						2.5x3	42 900	164 000	1 170			
DFT 5006-7.5	D						2.5x3	42 900	164 000	2 300			
SFT 5008-3	Clearance						8	4.762	50.5	45.5	1.5x2	25 000	77 400
DFT 5008-3	D		1.5x2	25 000	77 400	975							
SFT 5008-5	Clearance		2.5x2	38 700	131 000	815							
ZFT 5008-10	Z		2.5x2	38 700	131 000	1 600							
SFT 5008-7.5	Clearance		2.5x3	54 900	197 000	1 200							
DFT 5008-7.5	D		2.5x3	54 900	197 000	2 350							
SFT 5010-2.5	Clearance		10	6.35	51.0	44.4	2.5x1	31 800	87 400	440			
ZFT 5010-5	Z						2.5x1	31 800	87 400	866			
SFT 5010-3	Clearance						1.5x2	37 200	103 000	517			
DFT 5010-3	D						1.5x2	37 200	103 000	1 010			
ZFT 5010-7	Z						3.5x1	42 500	122 000	1 190			
PFT 5010-7.5	P						2.5x3	51 500	131 000	1 039			
SFT 5010-5	Clearance						2.5x2	57 700	175 000	853			
* ZFT 5010-10	Z	2.5x2					57 700	175 000	1 677				
SFT 5010-7.5	Clearance	2.5x3					81 800	262 000	1 250				
DFT 5010-7.5	D	2.5x3					81 800	262 000	2 460				
SFT 5012-2.5	Clearance	12					7.938	51.5	43.2	2.5x1	42 800	107 000	449
ZFT 5012-5	Z									2.5x1	42 800	107 000	883
SFT 5012-5	Clearance		2.5x2	77 600	214 000	869							
DFT 5012-5	D		2.5x2	77 600	214 000	1 718							
ZFT 5012-10	Z		2.5x2	77 600	214 000	1 718							
SFT 5016-2.5	Clearance		16	7.938	51.5	43.2				2.5x1	42 800	107 000	449
ZFT 5016-5	Z	2.5x1					42 800	107 000	883				
PFT 5016-7.5	P	2.5x3					69 300	161 000	1 066				
SFT 5016-5	Clearance	2.5x2					77 600	214 000	869				
DFT 5016-5	D	2.5x2					77 600	214 000	1 710				
SFT 5016-7.5	Clearance	2.5x3					110 000	321 000	1 286				
ZFT 5020-3	Z	20	7.938	51.5	43.2	1.5x1	27 600	64 300	542				
SFT 5020-2.5	Clearance					2.5x1	42 800	107 000	449				
DFT 5020-2.5	D					2.5x1	42 800	107 000	883				
SFT 5020-3	Clearance					1.5x2	50 000	129 000	534				
DFT 5020-3	D					1.5x2	50 000	129 000	1 050				

Notes: 1. Nut flange for shaft diameter 20 mm or larger comes in circular shape I and circular shape II. Select a flange that is suitable for the space available for nut installation.

2. If there is no seal for ZFT, SFT, and DFT, the nut length "L" is shortened by dimension "M".

3. The right turn screw is standard. "L" is added to the end of the model code for the left turn screw.

Ball nut dimensions

Nut entire length <i>L</i>	Nut diameter <i>D</i>	Flanged diameter <i>A</i>	Flanged width <i>B</i>	Notched flange <i>G</i>	Seal dimension <i>M</i>	Bolt hole dimension			Bolt hole PCD <i>W</i>	Oil hole <i>Q</i>
						<i>X</i>	<i>Y</i>	<i>Z</i>		
58	80	114	15	43	3	9	14	8.5	96	Rc1/8
83										
68										
103										
62	84	118	15	45	3	9	14	8.5	100	Rc1/8
116										
86										
68										
104										
86										
164	87	129	18	49	5	11	17.5	11	107	Rc1/8
74										
138										
85										
133										
109										
205										
73										
103	93	135	18	51	7	11	17.5	11	113	Rc1/8
170										
123										
133										
103	100	146	22	55	8	14	20	13	122	Rc1/8
103										
123										
231										
195										
104										
152	100	146	22	55	14	14	20	13	122	Rc1/8
200										
152										
280										
200	100	146	28	55	17	14	20	13	122	Rc1/8
200										
147										
127										
227										
147										
267										

4. The axial rigidity *K* in the table above is a theoretical value obtained from the elastic deformation between screw groove and ball when the axial load is 30% of the basic dynamic load rating (*C_d*) with non-preload, 10% with D-preload, and 5% with P-preload. Refer to "Technical Description" (page B37) if the axial load and preload differ from the conditions above, or when the deformation of the ball nut body must be considered.

5. The models marked with * (asterisk) are available in the SA type standard ball screws with finished shaft end.

6. Preload system: Z, Offset preload; D, Double nut preload (See page B5.)

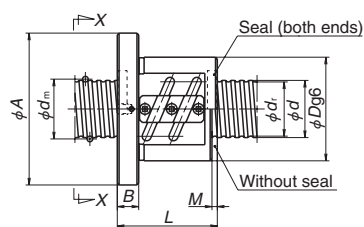

ZFT, SFT

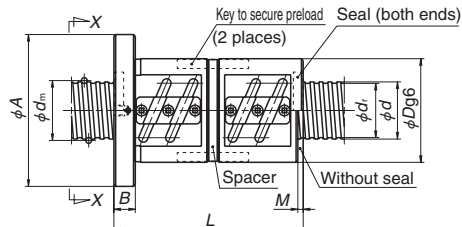

DFT

View X-X

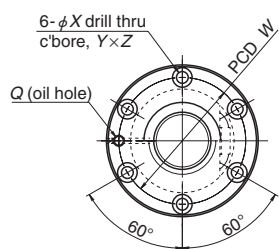

Circular shape I

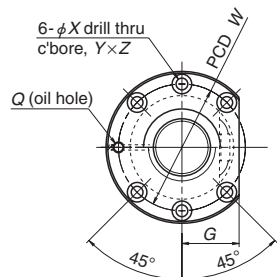

Circular shape II

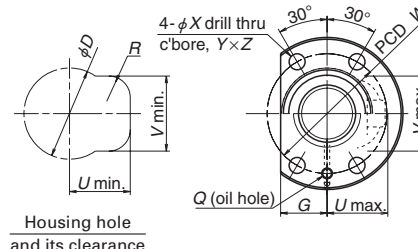

Housing hole and its clearance

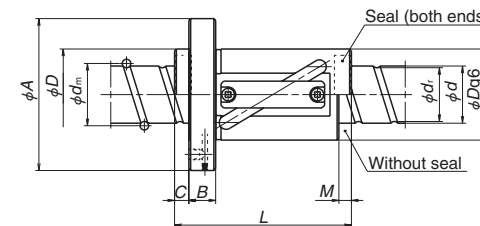

LPFT, LSFT

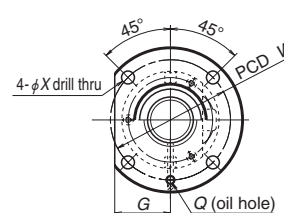

LDFT

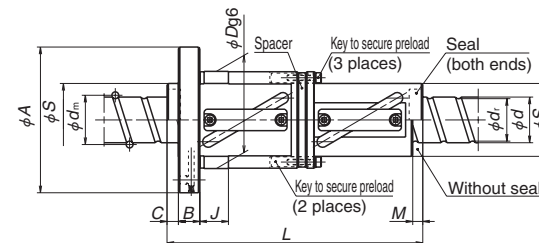

Unit: mm

Model No.	Preload system	Shaft dia. d	Lead l	Ball dia. D_w	Ball circle dia. d_m	Root dia. d_r	Effective turns of balls × Circuits	Basic load rating (N)		Axial rigidity K (N/μm)	Nut entire length L										
								Dynamic C_o	Static C_{0s}												
LPFT 5025-2.5	P	25	7.938	52.25	44	2.5×1	2.5×1	26 900	54 700	388	129										
LPFT 5025-3	P						1.5×2	31 400	66 500	450	154										
LSFT 5025-2.5	Clearance						2.5×1	42 700	109 000	462	129										
LDFT 5025-2.5	D						2.5×1	42 700	109 000	905	229										
LSFT 5025-3	Clearance						1.5×2	49 900	133 000	547	154										
LDFT 5025-3	D						1.5×2	49 900	133 000	1 070	279										
LPFT 5032-2.5	P						50	7.938	52.25	44	2.5×1	2.5×1	26 900	54 700	388	151					
LPFT 5032-3	P											1.5×2	31 400	66 500	450	183					
LSFT 5032-2.5	Clearance											2.5×1	42 700	109 000	462	151					
LDFT 5032-2.5	D											2.5×1	42 700	109 000	905	279					
LSFT 5032-3	Clearance											1.5×2	49 900	133 000	547	183					
LDFT 5032-3	D											1.5×2	49 900	133 000	1 070	343					
LPFT 5040-2.5	P	40	7.938	52.25	44	2.5×1						2.5×1	26 900	54 700	388	178					
LSFT 5040-2.5	Clearance											2.5×1	42 700	109 000	462	178					
LDFT 5040-2.5	D											2.5×1	42 700	109 000	922	338					
LPFT 5050-1.5	P											50	7.938	52.25	44	1.5×1	1.5×1	17 300	33 200	245	161
LSFT 5050-1.5	Clearance																1.5×1	27 500	66 500	290	161
LDFT 5050-1.5	D																1.5×1	27 500	66 500	572	312
ZFT 5510-5	Z						55	10	6.35	56.0	49.4						2.5×1	32 800	96 100	929	103
SFT 5510-5	Clearance																2.5×2	59 500	192 000	916	103
ZFT 5510-10	Z																2.5×2	59 500	192 000	1 800	163
DFT 5510-5	D																2.5×2	59 500	192 000	1 800	193
SFT 5510-7.5	Clearance																2.5×3	84 300	288 000	1 350	133
DFT 5510-7.5	D																2.5×3	84 300	288 000	2 650	253

- Notes: 1. Nut flange for shaft diameter 20 mm or larger comes in circular shape I and circular shape II. Select a flange that is suitable for the space available for nut installation.
 2. If there is no seal for ZFT, SFT, and DFT, the nut length "L" is shortened by dimension "M".
 3. If there is no seal for LSFT and LDFT of shaft diameter 25 mm or larger, the nut length "L" is shortened by dimension "M" and "C".
 4. The right turn screw is standard. "L" is added to the end of the model code for the left turn screw.

Ball nut dimensions																	
Nut diameter		Flanged diameter	Flanged width	Notched flange	Tube projecting type			Seal dimension		Diameter g6	Bolt hole dimension			Bolt hole PCD	Oil hole		
D	S	A	B	G	U	V	R	M	C	J	X	Y	Z	W	Q		
80	—	126	22	41	52	64	19	11	11	—	14	—	—	102	Rc1/8		
80	—	126		41	52	64	19			—				—		—	102
80	—	126		41	52	64	19			—				—		—	102
106	80	152		56	—	—	—			—				—		—	128
80	—	126		41	52	64	19			—				—		—	102
80	—	126		41	52	64	19			—				—		—	102
80	—	126		41	52	64	19			14				12		—	102
106	80	152		56	—	—	—			—				—		—	128
80	—	126		41	52	64	19			—				—		—	102
80	—	126		41	52	64	19			—				—		—	102
106	80	152		56	—	—	—			—				—		—	128
102	—	144		18	54	—	—			—				7		—	—

5. The axial rigidity K in the table above is a theoretical value obtained from the elastic deformation between screw groove and ball when the axial load is 30% of the basic dynamic load rating (C_o) with non-preload, 10% with D-preload, and 5% with P-preload. Refer to "Technical Description" (page B37) if the axial load and preload differ from the conditions above, or when the deformation of the ball nut body must be considered.
 6. For LPFT, the basic load ratings differ from the other models as the spacer balls are installed.
 7. Preload system: P, Oversize ball preload; Z, Offset preload; D, Double nut preload (See page B5).

Return tube type

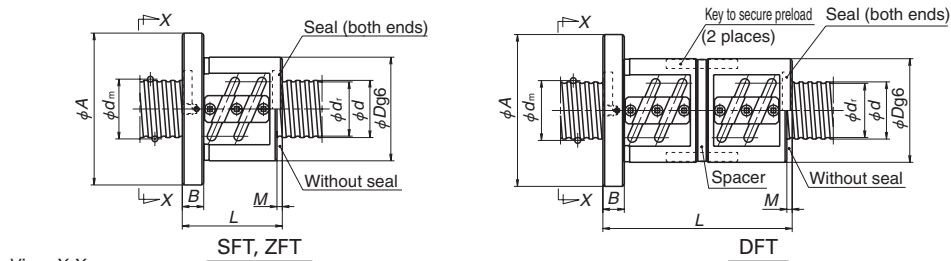

View X-X

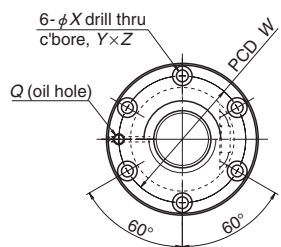

Circular shape I

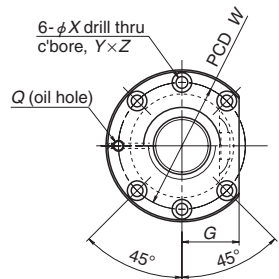

Circular shape II

Model No.	Preload system	Shaft dia. d	Lead l	Ball dia. D _w	Ball circle dia. d _m	Root dia. d _r	Effective turns of balls		Basic load rating (N)		Axial rigidity K (N/μm)	Nut entire length L
							Turns × Circuits	Dynamic C _d	Static C _{st}			
SFT 6310-2.5	Clearance Z	63	10	6.35	64.0	57.4	2.5×1	34 800	111 000	528	77	
ZFT 6310-5							2.5×1	34 800	111 000	1 038	107	
PFT 6310-7.5	Clearance Z	63	10	6.35	64.0	57.4	2.5×3	56 400	166 000	1 250	137	
SFT 6310-5							2.5×2	63 200	221 000	1 020	107	
ZFT 6310-10	Clearance D	63	10	6.35	64.0	57.4	2.5×2	63 200	221 000	2 000	167	
SFT 6310-7.5							2.5×3	89 500	332 000	1 500	137	
DFT 6310-7.5	Clearance D	63	10	6.35	64.0	57.4	2.5×3	89 500	332 000	2 950	257	
ZFT 6312-5							2.5×1	47 400	137 000	1 060	123	
SFT 6312-2.5	Clearance Z	63	12	7.938	64.5	56.2	2.5×1	47 400	137 000	542	87	
SFT 6312-5							2.5×2	86 000	273 000	1 050	123	
DFT 6312-5	Clearance D	63	12	7.938	64.5	56.2	2.5×2	86 000	273 000	2 060	231	
SFT 6316-2.5							2.5×1	79 500	228 000	713	110	
DFT 6316-2.5	Clearance D	63	16	9.525	65.0	55.2	2.5×1	79 500	228 000	1 400	206	
PFT 6316-5							2.5×2	90 900	228 000	1 136	158	
SFT 6316-5	Clearance D	63	16	9.525	65.0	55.2	2.5×2	144 000	455 000	1 380	158	
DFT 6316-5							2.5×2	144 000	455 000	2 710	302	
SFT 6320-2.5	Clearance D	63	20	9.525	65.0	55.2	2.5×1	79 500	228 000	713	127	
DFT 6320-2.5							2.5×1	79 500	228 000	1 400	227	
PFT 6320-5	Clearance D	63	20	9.525	65.0	55.2	2.5×2	90 900	228 000	1 132	187	
SFT 6320-5							2.5×2	144 000	455 000	1 380	187	
DFT 6320-5	Clearance D	63	20	9.525	65.0	55.2	2.5×2	144 000	455 000	2 710	347	
LPFT 6340-2.5							2.5×1	30 600	69 500	466	178	
LPFT 6340-3	Clearance D	63	40	7.938	65.25	57	1.5×2	35 800	82 500	551	218	
LSFT 6340-2.5							2.5×1	48 500	139 000	560	178	
LDFT 6340-2.5	Clearance D	63	40	7.938	65.25	57	2.5×1	48 500	139 000	1 100	339	
LSFT 6340-3							1.5×2	56 800	165 000	667	218	
LDFT 6340-3	Clearance D	63	40	7.938	65.25	57	1.5×2	56 800	165 000	1 310	419	
LPFT 6350-1.5							1.5×1	19 700	41 200	285	161	
LPFT 6350-2.5	Clearance D	63	50	7.938	65.25	57	2.5×1	30 600	69 500	478	211	
LSFT 6350-1.5							1.5×1	31 300	82 500	346	161	
LDFT 6350-1.5	Clearance D	63	50	7.938	65.25	57	1.5×1	31 300	82 500	678	311	
LSFT 6350-2.5							2.5×1	48 500	139 000	560	211	
LDFT 6350-2.5	Clearance D	63	50	7.938	65.25	57	2.5×1	48 500	139 000	1 120	411	
LDFT 6350-2.5							2.5×1	48 500	139 000	1 120	411	

- Notes: 1. Nut flange for shaft diameter 20 mm or larger comes in circular shape I and circular shape II. Select a flange that is suitable for the space available for nut installation.
 2. If there is no seal for ZFT, SFT, and DFT the nut length "L" is shortened by dimension "M".
 3. If there is no seal for LSFT and LDFT of shaft diameter 25 mm or larger, the nut length "L" is shortened by dimension "M" and "C".
 4. The right turn screw is standard. "L" is added to the end of the model code for the left turn screw.

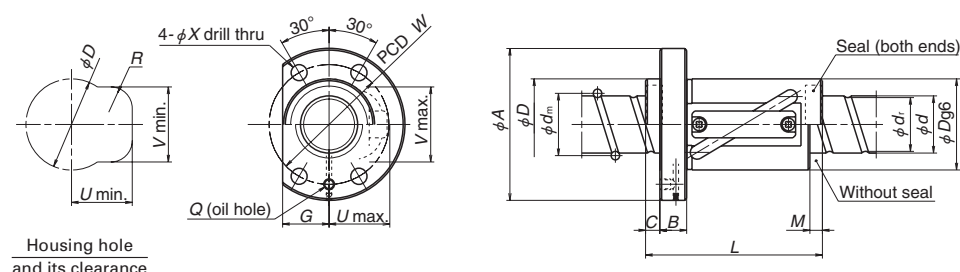

Housing hole and its clearance

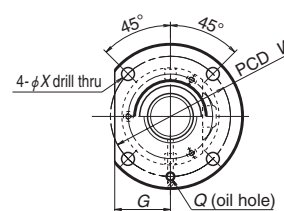

LPFT, LSFT

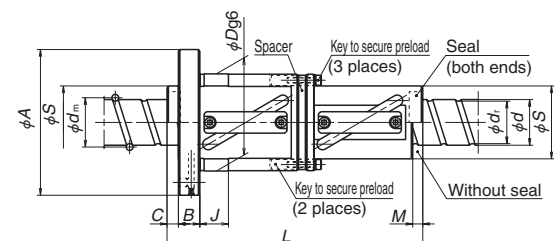

LDFT

Unit: mm

Ball nut dimensions															
Nut diameter		Flanged diameter	Flanged width	Notched flange	Tube projecting type			Seal dimension	Diameter g6	Bolt hole dimension			Bolt hole PCD	Oil hole	
D	S	A	B	G	U	V	R	M	C	J	X	Y	Z	W	Q
108	—	154	22	58	—	—	—	7	—	—	14	20	13	130	Rc1/8
115	—	161	22	61	—	—	—	8	—	—	14	20	13	137	Rc1/8
122	—	180	28	69	—	—	—	—	—	—	18	26	17.5	150	Rc1/8
122	—	180	28	69	—	—	—	17	—	—	18	26	17.5	150	Rc1/8
97	—	144	—	49	58	77	19	—	—	—	—	—	—	120	—
97	—	144	—	49	58	77	19	—	—	—	—	—	—	120	—
97	—	144	22	49	58	77	19	15	14	—	14	—	—	120	Rc1/8
122	97	168	—	62	—	—	—	—	—	29	—	—	—	144	—
97	—	144	—	49	58	77	19	—	—	—	—	—	—	120	—
122	97	168	—	62	—	—	—	—	—	29	—	—	—	144	—
97	—	144	—	49	58	77	19	—	—	—	—	—	—	120	—
97	—	144	—	49	58	77	19	—	—	—	—	—	—	120	—
122	97	168	—	62	—	—	—	19	16	—	14	—	—	120	Rc1/8
97	—	144	—	49	58	77	19	—	—	—	—	—	—	120	—
122	97	168	—	62	—	—	—	—	—	29	—	—	—	144	—

5. The axial rigidity K in the table above is a theoretical value obtained from the elastic deformation between screw groove and ball when the axial load is 30% of the basic dynamic load rating (C_d) with non-preload, 10% with D-preload, and 5% with P-preload. Refer to "Technical Description" (page B37) if the axial load and preload differ from the conditions above, or when the deformation of the ball nut body must be considered.
 6. For LPFT, the basic load ratings differ from the other models as the spacer balls are installed.
 7. Preload system: P, Oversize ball preload; Z, Offset preload; D, Double nut preload (See page B5.)

Return tube type

View X-X

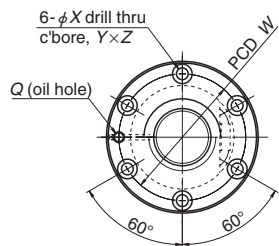

Circular shape I

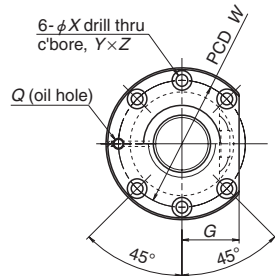

Circular shape II

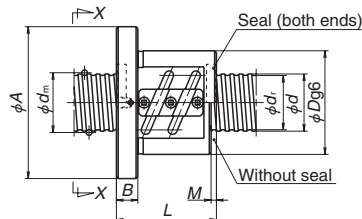

SFT

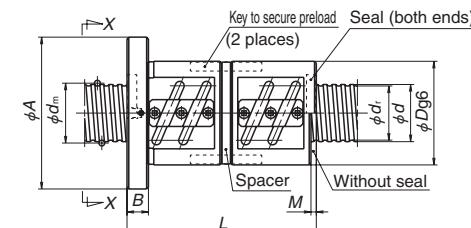

DFT

Unit: mm

Model No.	Preload system	Shaft dia. <i>d</i>	Lead <i>l</i>	Ball dia. <i>D_w</i>	Ball circle dia. <i>d_m</i>	Root dia. <i>d_i</i>	Effective turns of balls Turns × Circuits	Basic load rating (N)		Axial rigidity <i>K</i> (N/μm)				
								Dynamic <i>C_d</i>	Static <i>C_{0a}</i>					
SFT 8010-5	Clearance D	80	10	6.35	81.0	74.4	2.5×2	70 500	282 000	1 240				
DFT 8010-5							2.5×2	70 500	282 000	2 430				
SFT 8010-7.5	Clearance D						2.5×3	99 800	424 000	1 830				
DFT 8010-7.5							2.5×3	99 800	424 000	3 590				
SFT 8012-5	Clearance D						12	7.938	81.5	73.2	2.5×2	96 000	350 000	1 280
DFT 8012-5											2.5×2	96 000	350 000	2 500
SFT 8012-7.5	Clearance D		2.5×3	136 000	526 000	1 880								
DFT 8012-7.5			2.5×3	136 000	526 000	3 690								
SFT 8016-5	Clearance D		16	9.525	82.0	72.2					2.5×2	162 000	582 000	1 680
DFT 8016-5											2.5×2	162 000	582 000	3 300
SFT 8016-7.5	Clearance D						2.5×3	230 000	874 000	2 470				
DFT 8016-7.5							2.5×3	230 000	874 000	4 850				
SFT 8020-5	Clearance D	20					9.525	82.0	72.2	2.5×2	162 000	582 000	1 680	
DFT 8020-5										2.5×2	162 000	582 000	3 300	
SFT 8020-7.5	Clearance D		2.5×3	230 000	874 000	2 470								
DFT 8020-7.5			2.5×3	230 000	874 000	4 850								
SFT 10012-5	Clearance D		100	12	7.938	101.5				93.2	2.5×2	105 000	441 000	1 530
DFT 10012-5											2.5×2	105 000	441 000	2 990
SFT 10012-7.5	Clearance D	2.5×3					149 000	662 000	2 250					
DFT 10012-7.5		2.5×3					149 000	662 000	4 400					
SFT 10016-5	Clearance D	16					9.525	102	92.2		2.5×2	176 000	737 000	2 010
DFT 10016-5											2.5×2	176 000	737 000	3 930
SFT 10016-7.5	Clearance D			2.5×3	250 000	1 100 000				2 950				
DFT 10016-7.5				2.5×3	250 000	1 100 000				5 790				
SFT 10020-5	Clearance D			20	9.525	102				92.2	2.5×2	176 000	737 000	2 010
DFT 10020-5											2.5×2	176 000	737 000	3 930
SFT 10020-7.5	Clearance D	2.5×3					250 000	1 100 000	2 950					
DFT 10020-7.5		2.5×3					250 000	1 100 000	5 780					
SFT 12516-5	Clearance D	125	16				9.525	127	117.2		2.5×2	195 000	918 000	2 390
DFT 12516-5											2.5×2	195 000	918 000	4 690
SFT 12516-7.5	Clearance D			2.5×3	277 000	1 380 000				3 520				
DFT 12516-7.5				2.5×3	277 000	1 380 000				6 890				
SFT 12520-5	Clearance D			20	9.525	127				117.2	2.5×2	195 000	918 000	2 390
DFT 12520-5											2.5×2	195 000	918 000	4 690
SFT 12520-7.5	Clearance D	2.5×3	277 000				1 380 000	3 520						
DFT 12520-7.5		2.5×3	277 000				1 380 000	6 890						

- Notes: 1. Nut flange for shaft diameter 20 mm or larger comes in circular shape I and circular shape II. Select a flange that is suitable for the space available for nut installation.
 2. If there is no seal for SFT, and DFT, the nut length "L" is shortened by dimension "M".
 3. The right turn screw is standard. "L" is added to the end of the model code for the left turn screw.

Ball nut dimensions

Nut entire length <i>L</i>	Nut diameter <i>D</i>	Flanged diameter <i>A</i>	Flanged width <i>B</i>	Notched flange <i>G</i>	Seal dimension <i>M</i>	Bolt hole dimension			Bolt hole PCD <i>W</i>	Oil hole <i>Q</i>
						<i>X</i>	<i>Y</i>	<i>Z</i>		
107	130	176	22	66	7	14	20	13	152	Rc1/8
197										
137										
257										
123	136	182	22	68	8	14	20	13	158	Rc1/8
231										
159										
303										
158	143	204	28	77	10	18	26	17.5	172	Rc1/8
302										
206										
398										
187	143	204	28	77	17	18	26	17.5	172	Rc1/8
347										
247										
467										
129	160	220	28	82	8	18	26	17.5	188	Rc1/8
237										
165										
309										
162	170	243	32	91	10	22	32	21.5	205	Rc1/8
306										
210										
402										
191	170	243	32	91	17	22	32	21.5	205	Rc1/8
351										
251										
471										
170	200	290	36	109	10	26	39	25.5	243	Rc1/8
314										
218										
410										
199	200	290	36	109	12	26	39	25.5	243	Rc1/8
379										
259										
499										

4. The axial rigidity *K* in the table above is a theoretical value obtained from the elastic deformation between screw groove and ball when the axial load is 30% of the basic dynamic load rating (*C_d*) with non-preload, 10% with D-preload, and 5% with P-preload. Refer to "Technical Description" (page B37) if the axial load and preload differ from the conditions above, or when the deformation of the ball nut body must be considered.
 5. Preload system: D; Double nut preload (See page B5.)

Return tube type

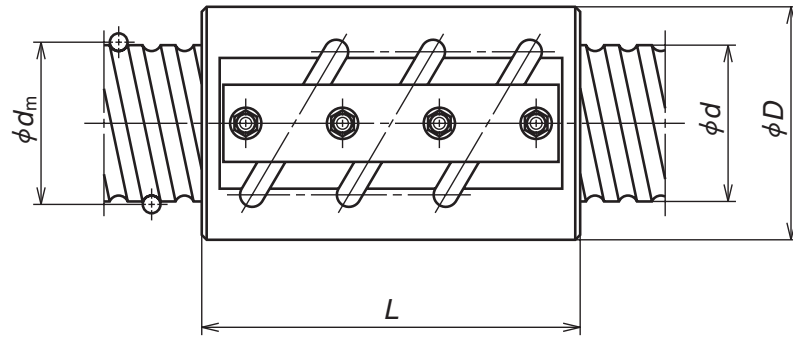

Nut model: GSCT (non-preload)

NSK

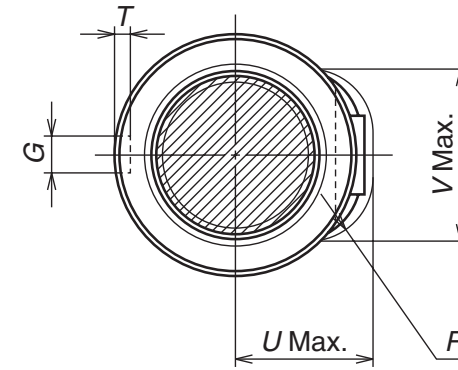

Unit: mm

Model No.	Axial play (Max.)	Shaft dia. d	Lead l	Ball dia. D_w	Ball circle dia. d_m	Root dia. d	Effective turns of balls Turns × Circuits	Basic load rating (N)		
								Dynamic C_a	Static C_{0a}	
GSCT14025-5	0.25	140	25	15.875	143	126.0	2.5×2	272 000	1 400 000	
GSCT14025-7.5							2.5×3	362 000	2 090 000	
GSCT14032-5	0.35		32	22.225	144	121.0	2.5×2	428 000	1 920 000	
GSCT14032-7.5							2.5×3	568 000	2 880 000	
GSCT14040-5	0.35		140	40	22.225	144	121.0	2.5×2	428 000	1 920 000
GSCT14040-7.5								2.5×3	568 000	2 880 000
GSCT14050-5	0.40	50		25.4	145	119.0	2.5×2	518 000	2 190 000	
GSCT14050-7.5							2.5×3	688 000	3 290 000	
GSCT16032-5	0.35	160	32	22.225	164	141.0	2.5×2	458 000	2 210 000	
GSCT16032-7.5							2.5×3	608 000	3 310 000	
GSCT16040-5	0.35		40	22.225	164	141.0	2.5×2	458 000	2 210 000	
GSCT16040-7.5							2.5×3	608 000	3 310 000	
GSCT16050-5	0.40		50	25.4	165	139.0	2.5×2	544 000	2 560 000	
GSCT16050-7.5							2.5×3	722 000	3 840 000	
GSCT20032-5	0.35	200	32	22.225	204	181.0	2.5×2	509 000	2 820 000	
GSCT20032-7.5							2.5×3	676 000	4 230 000	
GSCT20040-5	0.35		40	22.225	204	181.0	2.5×2	509 000	2 820 000	
GSCT20040-7.5							2.5×3	676 000	4 230 000	
GSCT20050-5	0.40		50	25.4	205	179.0	2.5×2	604 000	3 200 000	
GSCT20050-7.5							2.5×3	802 000	4 800 000	
GSCT25040-5	0.40	250	40	25.4	255	229.0	2.5×2	662 000	4 000 000	
GSCT25040-7.5							2.5×3	879 000	6 000 000	
GSCT25050-5	0.51		50	31.75	256	223.0	2.5×2	825 000	5 000 000	
GSCT25050-7.5							2.5×3	1 100 000	7 500 000	

Notes: 1. Precision grade is equivalent to Ct10 grade of JIS B1192 (see page B37).

2. The entire nut length (L) is the size without seal. The size with a seal is longer by the size of "MS."

Nut dimensions								
Nut entire length L	Nut diameter D	Key dimension		Tube projecting dimension			Seal dimension (MS)	
		G	T	U	V	R		
200	210	32	11	115	154	50	40	
275								
252	220			135	163	60	48	
348								
306				220	135	163	60	58
426								
377	225	141	167	70	70			
527								
252	245	36	12	141	180	60	48	
348								
306	245			141	180	60	58	
426								
377				250	147	185	70	70
527								
252	295	45	15	162	216	70	48	
348								
306	295			162	216	70	58	
426								
377				300	168	221	70	
527								
312	355	50	17	194	266	70	58	
432								
385	370			206	274	90	70	
535								

B-3-2.3 Deflector(bridge) Type Ball Screws

1. Features

The deflector(bridge) type has the smallest ball nut compared to the other recirculation systems, and suitable for fine lead operation.

2. Specifications

(1) Ball recirculation system

It has a small ball nut outside diameter, and suits for small lead ball screws. Fig.1 shows the structure of the deflector(bridge) recirculation system.

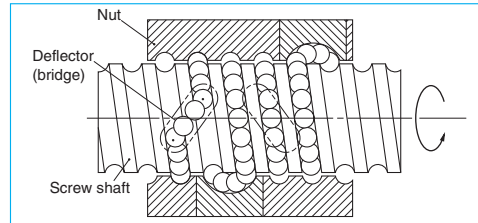

Fig. 1 Structure of deflector(bridge) recirculation system

Table 1 Accuracy grade and axial play

Accuracy grade	C0, C1, C2, C3, C5, Ct7 (Ct7 is not included in DFD)
Axial play	Z, 0 mm (preloaded); T, 0.005 mm or less S, 0.020 mm or less; N, 0.050 mm or less

Table 2 Deflector(bridge) type ball screw product categories

Nut model	Shape	Flange shape	Preload system
MSFD		Flanged Circular III	Non-preload, Slight axial play
MPFD			P-preload (light preload) no spacer ball
SFD		Screw shaft diameter of 16 mm or smaller: Flanged Screw shaft diameter of 20 mm or smaller: Rectangle Circular I, II	Non-preload, Slight axial play
ZFD		Flanged Circular I, II	Z-preload (medium preload)
DFD		Flanged Circular I, II	D-preload (medium preload) (heavy preload)

(2) Accuracy grade and axial play

The available standard accuracy grade and axial play are shown in Table 1. Please consult NSK for other grades.

(3) Allowable d·n value and the criterion of maximum rotational speed

The allowable d·n value and criterion of maximum rotational speed are shown below. Please consult NSK if the rotational speed exceeds the permissible range below. Basic measure must be taken for the high speed ball screws respectively.

Allowable d·n value:

Standard specification ; 84 000 or less

High-speed specification; 100 000 or less

Standard of rotational speed : 3 000 min⁻¹

Note: Please also review the critical speed. Refer to "Technical Description: Permissible Rotational Speed" (page B47) for details.

(4) Other specifications

Please consult NSK for other specifications not listed in the dimension tables.

3. Product categories

There are four different preload systems (Table 2). Synthetic resin that shows superb characteristics against wear is used in the recirculation deflector (bridge) for MSFD, MPFD, and has enhanced the smooth recirculation of balls. This product is being applied for a patent.

4. Design Precautions

When designing the screw shaft end, one end of the screw must meet either one of the following conditions. If not, we cannot install the ball nut on the screw shaft.

- Cut the ball groove through to the shaft end.

- The diameters of bearing journals and the gear or pulley seat must be less than the root diameter of ball groove "dr" specified on the dimension table.

For general precautions regarding ball screws, refer to "Design Precautions" (page B83) and "Handling Precautions" (page B103).

5. Structure of model number and reference number

The followings describe the structure of "Model number" and "Reference number for ball screw".

◇Model number

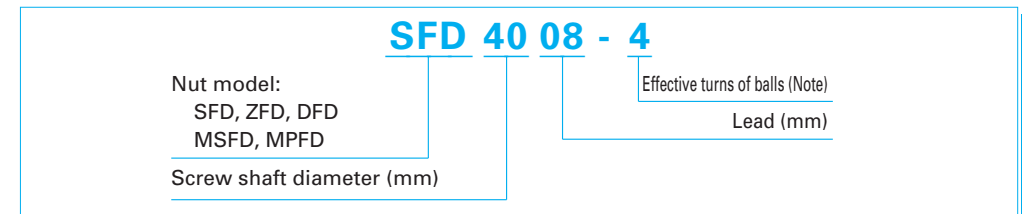

Note: In case of ZFD, the number here is twice as large as the effective turns of balls.

◇Reference number for ball screw

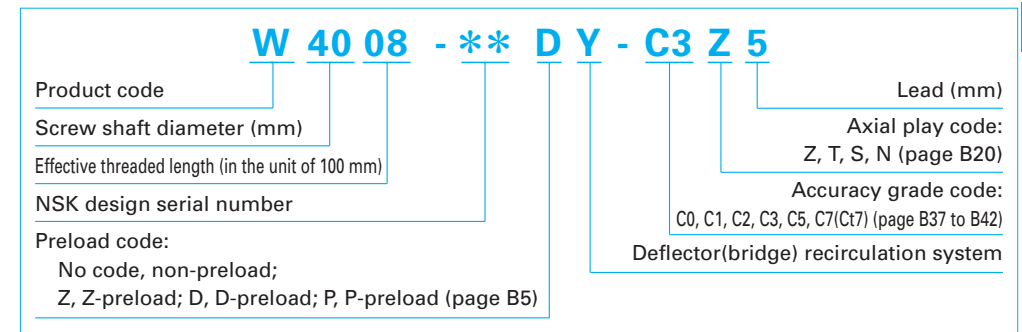

View X-X

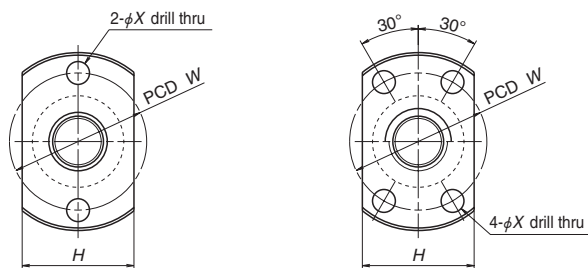

Lead $l = 0.5 \text{ mm}$

Lead $l > 1 \text{ mm}$

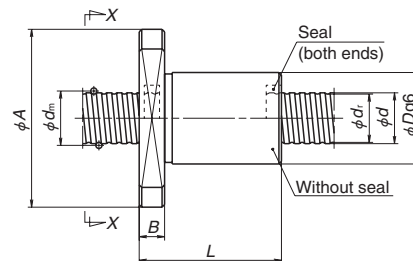

Unit: mm

Model No.	Preload system	Shaft dia. d	Lead l	Ball dia. D_w	Ball circle dia. d_m	Root dia. d_r	Effective turns of balls Turns × Circuits	Basic load rating (N)	
								Dynamic C_a	Static C_{0a}
MSFD 0400.5-3 MPFD 0400.5-3	Clearance P	4	0.5	0.400	4.1	3.6	1×3	170	280
MSFD 0401-2 MPFD 0401-2	Clearance P		1	0.800	4.2	3.2	1×2	315	370
MSFD 0600.5-3 MPFD 0600.5-3	Clearance P	6	0.5	0.400	6.1	5.6	1×3	205	430
MSFD 0601-3 MPFD 0601-3	Clearance P		1	0.800	6.2	5.2	1×3	575	925
MSFD 0602-3 MPFD 0602-3	Clearance P	6	2	0.800	6.2	5.2	1×3	575	925
MSFD 0800.5-3 MPFD 0800.5-3	Clearance P		0.5	0.400	8.1	7.6	1×3	230	595
MSFD 0801-3 MPFD 0801-3	Clearance P	8	1	0.800	8.2	7.2	1×3	670	1 290
MSFD 0801.5-3 MPFD 0801.5-3	Clearance P		1.5	1.000	8.3	7.0	1×3	1 080	1 980
MSFD 0802-3 MPFD 0802-3	Clearance P	8	2	1.200	8.3	6.9	1×3	1 320	2 210
MSFD 1001-3 MPFD 1001-3	Clearance P		1	0.800	10.2	9.2	1×3	745	1 660
MSFD 1002-3 MPFD 1002-3	Clearance P	10	2	1.200	10.3	8.9	1×3	1 490	2 850
MSFD 1002.5-3 MPFD 1002.5-3	Clearance P		2.5	1.588	10.4	8.6	1×3	2 130	3 640
MSFD 1201-3 MPFD 1201-3	Clearance P	12	1	0.800	12.2	11.2	1×3	795	1 980
MSFD 1202-3 MPFD 1202-3	Clearance P		2	1.200	12.3	10.9	1×3	1 660	3 620
MSFD 1202.5-3 MPFD 1202.5-3	Clearance P	12	2.5	1.588	12.4	10.6	1×3	2 360	4 540
MSFD 1203-3 MPFD 1203-3	Clearance P		3	2.000	12.5	10.2	1×3	3 120	5 420
MSFD 1402-3 MPFD 1402-3	Clearance P	14	2	1.200	14.3	12.9	1×3	1 780	4 270
MSFD 1403-3 MPFD 1403-3	Clearance P		3	2.000	14.5	12.2	1×3	3 400	6 490

Notes: 1. If the shaft OD is less than 6 mm or the lead is less than 1 mm, a seal is not installed in the nut. (See page B68 for dust protection.)

2. Ball nuts with shaft diameters under 14 mm do not have oil holes.

3. Right turn screw is standard. Please consult NSK for left turn screw.

Axial rigidity K (N/μm)	Ball nut dimensions						
	Nut entire length L	Nut diameter D	Flanged diameter A	Flanged width B	Flanged dimension H	Bolt hole dimension X	Bolt hole PCD W
30	13	10	22	3	11	3.4	16
47							
22	12	10	20	3	14	2.9	15
34							
42	13	12	24	3	13	3.4	18
66							
49	15	12	24	3.5	16	3.4	18
76							
49	17	13	25	4	17	3.4	19
76							
54	13	14	27	3	15	3.4	21
85							
64	16	14	27	4	18	3.4	21
99							
76	22	15	28	4	19	3.4	22
117							
73	26	16	29	4	20	3.4	23
113							
77	16	16	29	4	20	3.4	23
120							
91	28	18	35	5	22	4.5	27
138							
90	32	19	36	5	23	4.5	28
140							
88	16	18	31	4	22	3.4	25
137							
108	28	20	37	5	24	4.5	29
168							
107	32	21	38	5	25	4.5	30
167							
107	36	22	39	5	26	4.5	31
166							
122	29	22	41	6	26	5.5	32
191							
127	37	24	43	6	28	5.5	34
196							

4. The axial rigidity K in the table above is a theoretical value obtained from the elastic deformation between screw groove and ball when the axial load is 30% of the basic dynamic load rating (C_a) with non-preload, 10% with D-preload, and 5% with P-preload. Refer to "Technical Description" (page B37) if the axial load and preload differ from the conditions above, or when the deformation of the ball nut body must be considered.

5. The models marked with * (asterisk) are available in the MA type standard ball screw with finished shaft end.

6. Preload system: P; Oversize ball preload (See page B5.)

Deflector(bridge) type

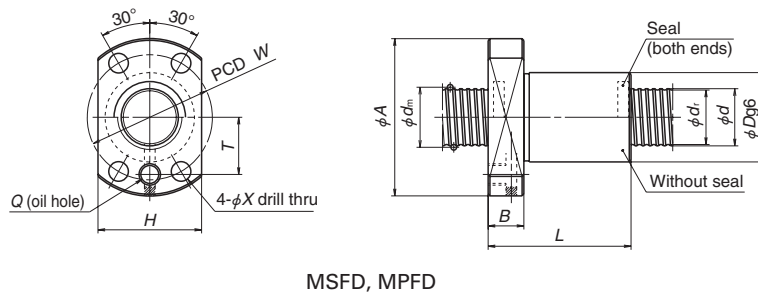
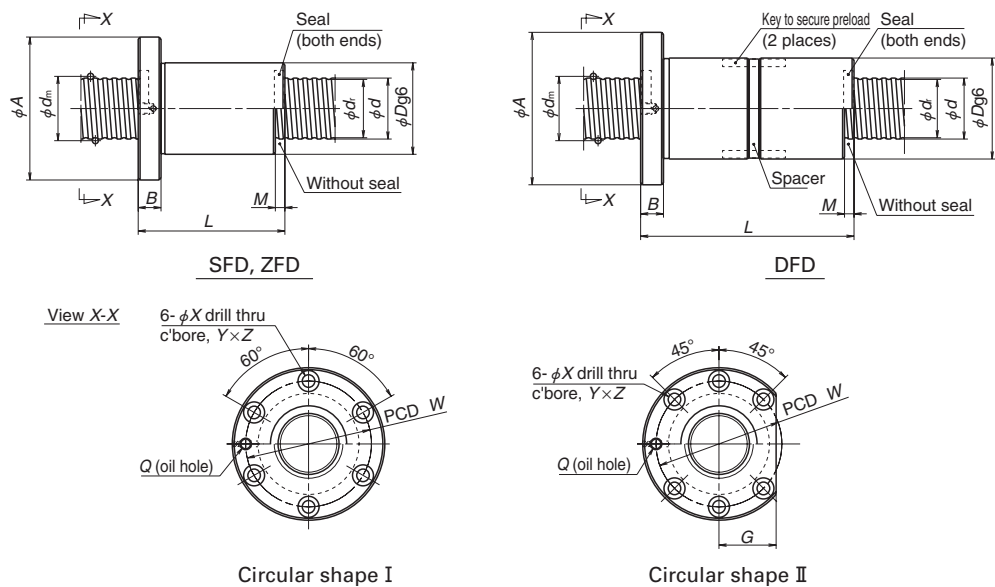

Unit: mm

Model No.	Preload system	Shaft dia. <i>d</i>	Lead <i>l</i>	Ball dia. <i>D_w</i>	Ball circle dia. <i>d_m</i>	Root dia. <i>d_r</i>	Effective turns of balls Turns × Circuits	Basic load rating (N)		Axial rigidity <i>K</i> (N/μm)
								Dynamic <i>C_a</i>	Static <i>C_{0a}</i>	
MSFD 1602-4	Clearance P	16	2	1.588	16.4	14.6	1×4	3 510	8 450	185
MPFD 1602-4	P									288
MSFD 1602.5-4	Clearance P	16	2.5	1.588	16.4	14.6	1×4	3 510	8 450	185
MPFD 1602.5-4	P									288
MSFD 2002-4	Clearance P	20	2	1.588	20.4	18.6	1×4	3 910	10 900	225
MPFD 2002-4	P									351
SFD 2005-3	Clearance Z	20	5	3.175	20.75	17.4	1×3	8 620	17 500	196
ZFD 2005-6	Z						1×3	8 620	17 500	382
SFD 2005-4	Clearance D	20	5	3.175	20.75	17.4	1×4	11 000	23 300	255
DFD 2005-4	D						1×4	11 000	23 300	509
SFD 2006-3	Clearance Z	20	6	3.969	21	16.9	1×3	11 100	20 600	196
ZFD 2006-6	Z						1×3	11 100	20 600	382
SFD 2006-4	Clearance D	20	6	3.969	21	16.9	1×4	14 300	27 500	255
DFD 2006-4	D						1×4	14 300	27 500	498
MSFD 2502-4	Clearance P	25	2	1.588	25.4	23.6	1×4	4 310	13 900	273
MPFD 2502-4	P									425
SFD 2505-3	Clearance Z	25	5	3.175	25.75	22.4	1×3	9 790	22 900	245
ZFD 2505-6	Z						1×3	9 790	22 900	480
SFD 2505-4	Clearance D	25	5	3.175	25.75	22.4	1×4	12 500	30 500	323
DFD 2505-4	D						1×4	12 500	30 500	630
SFD 2506-3	Clearance Z	25	6	3.969	26	21.9	1×3	12 900	27 300	245
ZFD 2506-6	Z						1×3	12 900	27 300	470
SFD 2506-4	Clearance D	25	6	3.969	26	21.9	1×4	16 500	36 500	323
DFD 2506-4	D						1×4	16 500	36 500	626
SFD 2510-4	Z	10	4.762	26.25	21.3	21.3	1×2	11 400	21 400	323
SFD 2510-3	Clearance D						1×3	16 100	32 000	245
DFD 2510-3	D						1×3	16 100	32 000	479

Nut entire length <i>L</i>	Nut diameter <i>D</i>	Flanged diameter <i>A</i>	Flanged width <i>B</i>	Ball nut dimensions									
				Notched flange		Seal dimension <i>M</i>	Bolt hole dimension			Bolt hole PCD <i>W</i>	Oil hole dimension <i>T</i>	Oil hole <i>Q</i>	
				<i>G</i>	<i>H</i>		<i>X</i>	<i>Y</i>	<i>Z</i>				
40	25	44	10	—	29	—	5.5	—	—	35	16	M6×1	
44	25	44	10	—	29	—	5.5	—	—	35	16	M6×1	
40	30	49	10	—	34	—	5.5	—	—	40	18.5	M6×1	
46	35	58	10	22.5	—	—	5	5.5	9.5	5.5	46	—	M6×1
66	35	58	11	22.5	—	—	5	5.5	9.5	5.5	46	—	M6×1
51	35	58	11	22.5	—	—	5	5.5	9.5	5.5	46	—	M6×1
91	41	64	11	25	—	—	6	5.5	9.5	5.5	46	—	M6×1
52	35	58	11	22.5	—	—	6	5.5	9.5	5.5	46	—	M6×1
76	35	58	11	22.5	—	—	6	5.5	9.5	5.5	46	—	M6×1
60	35	58	11	22.5	—	—	6	5.5	9.5	5.5	46	—	M6×1
108	42	65	11	25	—	—	6	5.5	9.5	5.5	53	—	M6×1
40	36	55	10	—	40	—	5.5	—	—	46	21.5	M6×1	
46	40	63	11	24	—	—	5	5.5	9.5	5.5	51	—	M6×1
66	40	63	11	24	—	—	5	5.5	9.5	5.5	51	—	M6×1
51	40	63	11	24	—	—	5	5.5	9.5	5.5	51	—	M6×1
91	46	69	11	26	—	—	6	5.5	9.5	5.5	57	—	M6×1
52	40	63	11	24	—	—	6	5.5	9.5	5.5	51	—	M6×1
76	40	63	11	24	—	—	6	5.5	9.5	5.5	51	—	M6×1
60	40	63	11	24	—	—	6	5.5	9.5	5.5	51	—	M6×1
108	47	70	11	27	—	—	6	5.5	9.5	5.5	58	—	M6×1
88	42	69	15	26	—	—	10	6.6	11	6.5	55	—	M6×1
80	42	69	15	26	—	—	10	6.6	11	6.5	55	—	M6×1
140	47	74	15	28	—	—	10	6.6	11	6.5	60	—	M6×1

- Notes: 1. Nut comes in circular shape I and circular shape II for shaft diameter 20 mm or larger. Select a flange that is suitable for the space available for nut installation.
2. If there is no seal for SFD, ZFD, and DFD, the nut length "L" is shortened by dimension "M". For MSFD and MPFD, the nut length is the same as those with seal.
3. The right turn screw is standard. "L" is added to the end of the model code for the left turn screw. Please consult NSK for MSFD and MPFD.

4. The axial rigidity *K* in the table above is a theoretical value obtained from the elastic deformation between screw groove and ball when the axial load is 30% of the basic dynamic load rating (*C_a*) with non-preload, 10% with D-preload, and 5% with P-preload. Refer to "Technical Description" (page B37) if the axial load and preload differ from the conditions above, or when the deformation of the ball nut body must be considered.
5. It is recommended to use with seals when the shaft diameter is 16 mm or over and an oil hole is provided on the ball nut.
6. The models marked with * (asterisk) are available in the MA type standard ball screw with finished shaft end.
7. Preload system: Z, Offset preload; P, Oversize ball preload; D, Double nut preload (See page B5.)

Deflector(bridge) type

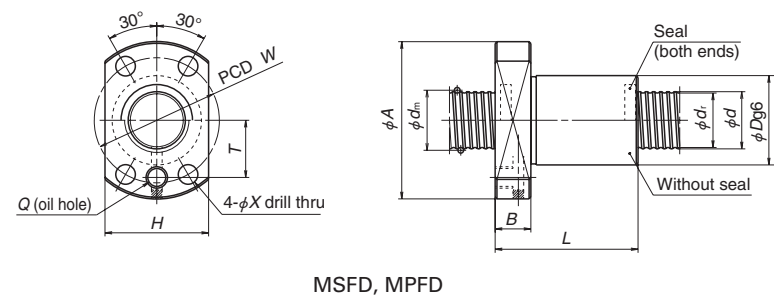
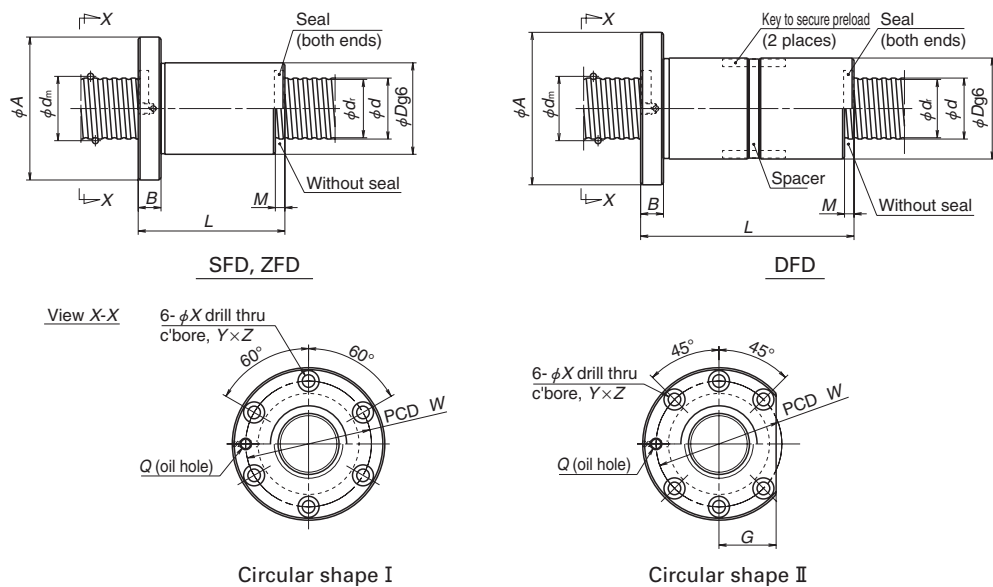

Unit: mm

Model No.	Preload system	Shaft dia. <i>d</i>	Lead <i>l</i>	Ball dia. <i>D_w</i>	Ball circle dia. <i>d_m</i>	Root dia. <i>d_r</i>	Effective turns of balls Turns × Circuits	Basic load rating (N)		Axial rigidity <i>K</i> (N/μm)										
								Dynamic <i>C_a</i>	Static <i>C_{0a}</i>											
MSFD 3202-6	Clearance	32	2	1.588	32.4	30.6	1×6	6 790	27 200	494										
MPFD 3202-6	P									769										
SFD 3205-3	Clearance									5	3.175	32.75	29.4	1×3	11 100	30 500	304			
ZFD 3205-6	Z																598			
SFD 3205-4	Clearance																1×4	14 200	40 700	409
ZFD 3205-8	Z																			784
SFD 3205-6	Clearance		1×6	20 200	61 000	588														
DFD 3205-6	D					1 160														
SFD 3206-3	Clearance		6	3.969	33	28.9	1×3	15 000	37 500	314										
ZFD 3206-6	Z									608										
SFD 3206-4	Clearance									1×4	19 200	49 900	412							
ZFD 3206-8	Z												804							
SFD 3206-6	Clearance												1×6	27 200	74 900	598				
DFD 3206-6	D															1 190				
SFD 3208-3	Clearance		8	4.762	33.25	28.3	1×3	18 300	41 800	304										
ZFD 3208-6	Z									588										
SFD 3208-4	Clearance									1×4	23 500	55 800	392							
ZFD 3208-8	Z												774							
SFD 3210-3	Clearance												1×3	25 900	52 800	300				
ZFD 3210-6	Z															588				
SFD 3210-4	Clearance		1×4	33 200	70 300	392														
DFD 3210-4	D					773														

Notes: 1. Nut comes in circular shape I and circular shape II for shaft diameter 20 mm or larger. Select a flange that is suitable for the space available for nut installation.
 2. If there is no seal for SFD, ZFD, and DFD, the nut length "L" is shortened by dimension "M". For MSFD and MPFD, the nut length is the same as those with seal.
 3. The right turn screw is standard. "L" is added to the end of the model code for the left turn screw. Please consult NSK for MSFD and MPFD.

Nut entire length <i>L</i>	Nut diameter <i>D</i>	Flanged diameter <i>A</i>	Flanged width <i>B</i>	Ball nut dimensions		Seal dimension <i>M</i>	Bolt hole dimension			Bolt hole PCD <i>W</i>	Oil hole dimension <i>T</i>	Oil hole <i>Q</i>
				Notched flange			<i>X</i>	<i>Y</i>	<i>Z</i>			
				<i>G</i>	<i>H</i>							
50	42	65	10	—	46	—	6.6	—	—	54	26.5	M6×1
47	48	75	12	29	—	5	6.6	11	6.5	61	—	M6×1
67	48	75		29						61		
52	48	75		29						61		
77	48	75		29						61		
62	48	75		29						61		
112	53	80		30						66		
53	48	75	12	29	—	6	6.6	11	6.5	61	—	M6×1
77	48	75		29						61		
61	48	75		29						61		
90	48	75		29						61		
73	48	75		29						61		
133	54	81		31						67		
67	50	84	15	32	—	8	9	14	8.5	66	—	M6×1
99												
76												
116												
80												
120												
90	54	88	15	34	—	10	9	14	8.5	70	—	M6×1
160												

4. The axial rigidity *K* in the table above is a theoretical value obtained from the elastic deformation between screw groove and ball when the axial load is 30% of the basic dynamic load rating (*C_a*) with non-preload, 10% with D-preload, and 5% with P-preload. Refer to "Technical Description" (page B37) if the axial load and preload differ from the conditions above, or when the deformation of the ball nut body must be considered.
 5. It is recommended to use with seals when the shaft diameter is 16 mm or over and an oil hole is provided on the ball nut.
 6. The models marked with * (asterisk) are available in the SS type standard ball screw with finished shaft end.
 7. Preload system: Z, Offset preload; P, Oversize ball preload; D, Double nut preload (See page B5.)

Deflector(bridge) type

Deflector(bridge) type

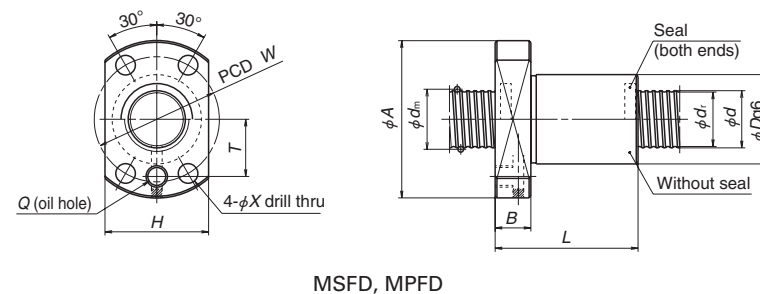
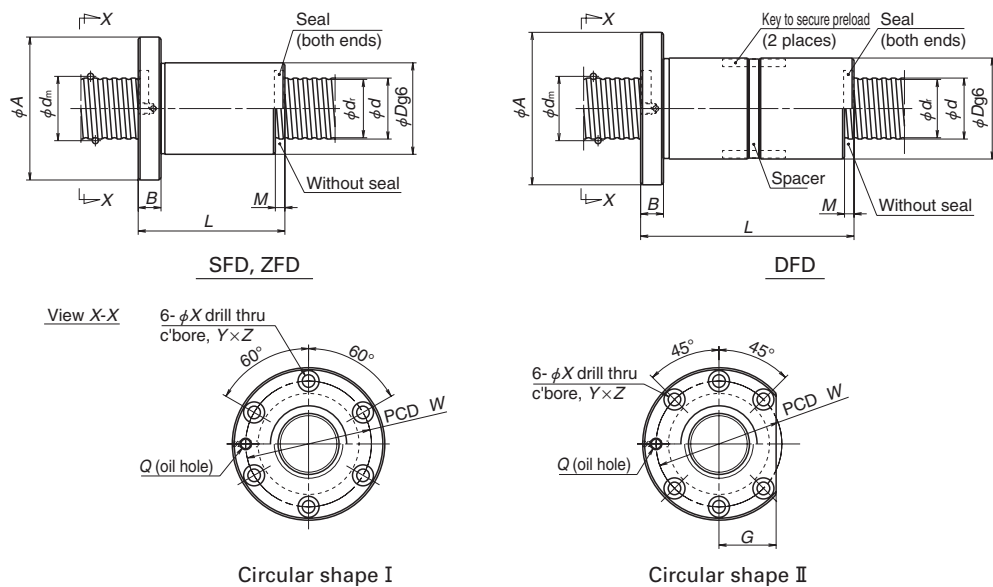

Unit: mm

Model No.	Preload system	Shaft dia. <i>d</i>	Lead <i>l</i>	Ball dia. <i>D_w</i>	Ball circle dia. <i>d_m</i>	Root dia. <i>d_r</i>	Effective turns of balls Turns × Circuits	Basic load rating (N)		Axial rigidity <i>K</i> (N/μm)
								Dynamic <i>C_a</i>	Static <i>C_{0a}</i>	
MSFD 4002-6	Clearance P	40	2	1.588	40.4	38.6	1×6	7 380	33 900	588
MPFD 4002-6	Z									916
SFD 4005-4			Z	5	3.175	40.75	37.4	1×4	15 800	52 300
ZFD 4005-8	Z									
SFD 4005-6			Z	6	3.969	41.0	36.9	1×6	22 400	78 400
ZFD 4005-12	Z									
SFD 4006-4			Z	8	4.762	41.25	36.3	1×4	21 300	63 500
ZFD 4006-8	Z									
SFD 4006-6			Z	10	6.35	41.75	35.1	1×6	30 100	95 300
ZFD 4006-12	Z									
SFD 4008-4			Z	5	3.175	50.75	47.4	1×4	17 500	66 800
ZFD 4008-8	Z									
SFD 4008-6		Z	6	3.969	51.0	46.9	1×6	24 800	100 000	872
DFD 4008-6	D									1 720
SFD 4010-3		Z	5	3.175	50.75	47.4	1×4	17 500	66 800	593
ZFD 4010-6	Z									1 170
SFD 4010-4		Z	6	3.969	51.0	46.9	1×6	24 800	100 000	872
ZFD 4010-8	Z									1 720
SFD 5005-4		Z	5	3.175	50.75	47.4	1×4	17 500	66 800	593
ZFD 5005-8	Z									1 170
SFD 5005-6		Z	6	3.969	51.0	46.9	1×6	24 800	100 000	872
ZFD 5005-12	Z									1 720
SFD 5006-4		Z	5	3.175	50.75	47.4	1×4	17 500	66 800	593
ZFD 5006-8	Z									1 170
SFD 5006-6		Z	6	3.969	51.0	46.9	1×6	24 800	100 000	892
ZFD 5006-12	Z									1 750

- Notes: 1. Nut comes in circular shape I and circular shape II for shaft diameter 20 mm or larger. Select a flange that is suitable for the space available for nut installation.
 2. If there is no seal for SFD, ZFD, and DFD, the nut length "L" is shortened by dimension "M". For MSFD and MPFD, the nut length is the same as those with seal.
 3. The right turn screw is standard. "L" is added to the end of the model code for the left turn screw. Please consult NSK for MSFD and MPFD.

Ball nut dimensions													
Nut entire length <i>L</i>	Nut diameter <i>D</i>	Flanged diameter <i>A</i>	Flanged width <i>B</i>	Notched flange		Seal dimension <i>M</i>	Bolt hole dimension			Bolt hole PCD <i>W</i>	Oil hole dimension <i>T</i>	Oil hole	
				<i>G</i>	<i>H</i>		<i>X</i>	<i>Y</i>	<i>Z</i>				
50	51	74	10	—	55	—	6.6	—	—	63	31	M6×1	
55	56	90	15	34	—	5	9	14	8.5	72	—	Rc1/8	
80													
65													
101													
64	56	90	15	34	—	6	9	14	8.5	72	—	Rc1/8	
93													
76													
118													
76	60	94	15	36	—	8	9	14	8.5	76	—	Rc1/8	
116													
93													
168													
62	62	104	18	40	—	10	11	17.5	11	82	—	Rc1/8	
83													
123													
93													
143	66	100	15	38	—	5	9	14	8.5	82	—	Rc1/8	
55													
80													
65													
101	66	100	15	38	—	6	9	14	8.5	82	—	Rc1/8	
64													
93													
76													
118													

4. The axial rigidity *K* in the table above is a theoretical value obtained from the elastic deformation between screw groove and ball when the axial load is 30% of the basic dynamic load rating (*C_a*) with non-preload, 10% with D-preload, and 5% with P-preload. Refer to "Technical Description" (page B37) if the axial load and preload differ from the conditions above, or when the deformation of the ball nut body must be considered.
 5. It is recommended to use with seals when the shaft diameter is 16 mm or over and an oil hole is provided on the ball nut.
 6. Preload system: Z, Offset preload; P, Oversize ball preload; D, Double nut preload (See page B5.)

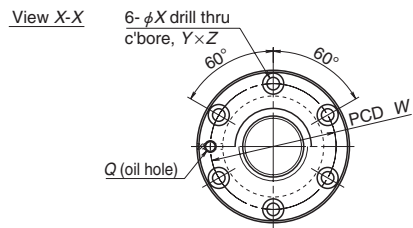

Circular shape I

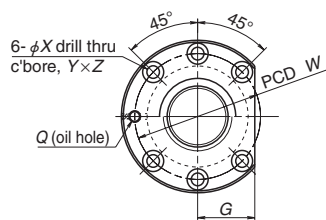

Circular shape II

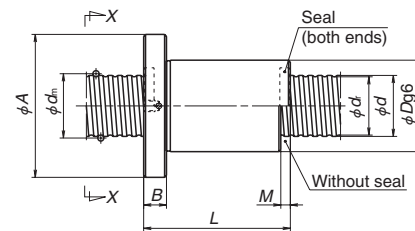

SFD, ZFD

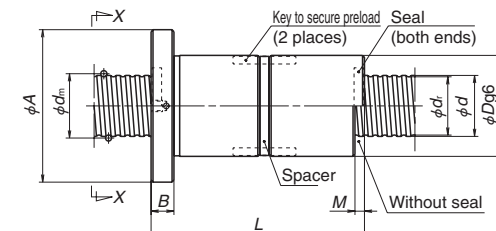

DFD

Unit: mm

Model No.	Preload system	Shaft dia. <i>d</i>	Lead <i>l</i>	Ball dia. <i>D_w</i>	Ball circle dia. <i>d_m</i>	Root dia. <i>d_r</i>	Effective turns of balls Turns × Circuits	Basic load rating (N)		Axial rigidity <i>K</i> (N/μm)								
								Dynamic <i>C_d</i>	Static <i>C_{0a}</i>									
SFD 5008-4	Clearance	50	8	4.762	51.25	46.3	1×4	29 900	94 800	598								
ZFD 5008-8	Z						1×4	29 900	94 800	1 180								
SFD 5008-6	Clearance						1×6	42 400	142 000	887								
DFD 5008-6	D						1×6	42 400	142 000	1 740								
SFD 5010-3	Clearance						1×3	34 100	91 600	461								
ZFD 5010-6	Z						1×3	34 100	91 600	914								
SFD 5010-4	Clearance		10	6.35	51.75	45.1	1×4	43 600	122 000	608								
ZFD 5010-8	Z						1×4	43 600	122 000	1 200								
SFD 5010-6	Clearance						1×6	61 800	183 000	902								
DFD 5010-6	D						1×6	61 800	183 000	1 770								
SFD 5012-3	Clearance						1×3	44 800	109 000	461								
ZFD 5012-6	Z						1×3	44 800	109 000	906								
SFD 5012-4	Clearance	12	7.938	52.25	44	1×4	57 300	146 000	608									
DFD 5012-4	D					1×4	57 300	146 000	1 200									
SFD 5020-3	Clearance					20	7.938	52.25	44	1×3	44 800	109 000	461					
DFD 5020-3	D									1×3	44 800	109 000	908					
SFD 6306-4	Clearance									63	6	3.969	64.0	59.9	1×4	26 100	104 000	735
ZFD 6306-8	Z														1×4	26 100	104 000	1 430
SFD 6306-6	Clearance	1×6	36 900	157 000	1 180													
ZFD 6306-12	Z	1×6	36 900	157 000	2 110													
SFD 6308-4	Clearance	8	4.762	64.25	59.3	1×4	33 600	124 000	745									
ZFD 6308-8	Z					1×4	33 600	124 000	1 460									
SFD 6308-6	Clearance					1×6	47 600	186 000	1 100									
DFD 6308-6	D					1×6	47 600	186 000	2 150									
SFD 6310-4	Clearance					10	6.35	64.75	58.1		1×4	49 700	163 000	764				
ZFD 6310-8	Z										1×4	49 700	163 000	1 510				
SFD 6310-6	Clearance	1×6	70 500	244 000	1 130													
DFD 6310-6	D	1×6	70 500	244 000	2 210													
ZFD 6312-6	Z	1×3	50 800	143 000	1 120													
SFD 6312-4	Clearance	12	7.938	65.25	57					1×4	65 100	191 000	755					
DFD 6312-4	D					1×4	65 100	191 000	1 480									
SFD 6312-6	Clearance					1×6	92 200	286 000	1 110									
DFD 6312-6	D					1×6	92 200	286 000	2 180									
SFD 6320-3	Clearance					20	9.525	65.75	56	1×3	83 700	232 000	735					
DFD 6320-3	D										1 440							

Notes: 1. Nut comes in circular shape I and circular shape II for shaft diameter 20 mm or larger. Select a flange that is suitable for the space available for nut installation.

2. If there is no seal the nut length "L" is shortened by dimension "M".

3. The right turn screw is standard. "L" is added to the end of the model code for the left turn screw.

Nut entire length <i>L</i>	Nut diameter <i>D</i>	Flanged diameter <i>A</i>	Flanged width <i>B</i>	Notched flange <i>G</i>	Seal dimension <i>M</i>	Ball nut dimensions			Bolt hole PCD <i>W</i>	Oil hole <i>Q</i>
						Bolt hole dimension				
						<i>X</i>	<i>Y</i>	<i>Z</i>		
79	70	112		43	8	11	17.5	11	90	Rc1/8
119	70	112	18	43						
96	70	112		43						
171	72	114		44						
83										
123					10	11	17.5	11	92	Rc1/8
93	72	114	18	44						
143										
114										
205										
99					12	14	20	13	97	Rc1/8
147	75	121	22	47						
111										
195										
146										
253	75	121	28	47	20	14	20	13	97	Rc1/8
67										
96	80	122	18	47						
79										
121										
79	82	124		47	8	11	17.5	11	102	Rc1/8
119	82	124	18	47						
96	82	124		47						
175	85	127		48						
97										
147					10	14	20	13	107	Rc1/8
118	85	131	22	50						
214										
147										
111										
195	90	136	22	52	12	14	20	13	112	Rc1/8
136										
248										
146										
253	95	153	28	59						

4. The axial rigidity *K* in the table above is a theoretical value obtained from the elastic deformation between screw groove and ball when the axial load is 30% of the basic dynamic load rating (*C_d*) with non-preload, 10% with D-preload, and 5% with P-preload. Refer to "Technical Description" (page B37) if the axial load and preload differ from the conditions above, or when the deformation of the ball nut body must be considered.

5. It is recommended to use with seals when the shaft diameter is 16 mm or over and an oil hole is provided on the ball nut.

6. Preload system: Z, Offset preload; D, Double nut preload (See page B5.)

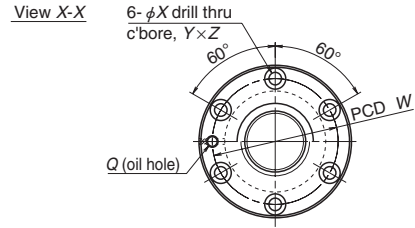

Circular shape I

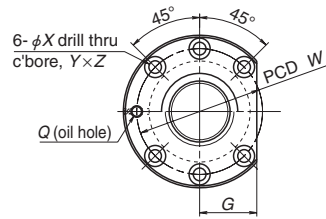

Circular shape II

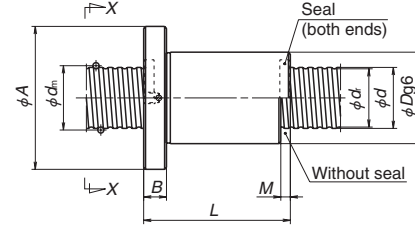

SFD

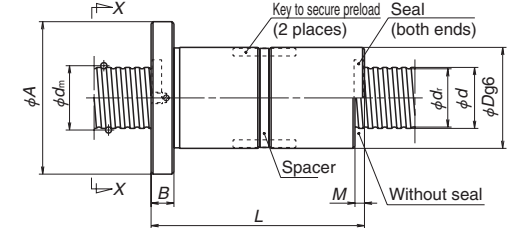

DFD

Model No.	Preload system	Shaft dia. <i>d</i>	Lead <i>l</i>	Ball dia. <i>D_w</i>	Ball circle dia. <i>d_m</i>	Root dia. <i>d_r</i>	Effective turns of balls Turns × Circuits	Basic load rating (N)		Axial rigidity <i>K</i> (N/μm)							
								Dynamic <i>C_a</i>	Static <i>C_{0a}</i>								
SFD 8010-4	Clearance D	80	10	6.35	81.75	75.1	1×4	55 100	209 000	931							
DFD 8010-4	Clearance D						1×4	55 100	209 000	1 840							
SFD 8010-6							1×6	78 000	314 000	1 370							
DFD 8010-6	Clearance D						1×6	78 000	314 000	2 710							
SFD 8012-4							Clearance D	1×4	74 000	254 000	941						
DFD 8012-4	Clearance D						1×4	74 000	254 000	1 860							
SFD 8012-6			Clearance D	1×6	105 000	381 000	1 392										
DFD 8012-6	Clearance D		1×6	105 000	381 000	2 730											
SFD 8020-3			Clearance D	20	9.525	82.75	73	1×3	96 600	313 000	931						
DFD 8020-3	Clearance D		1×3					96 600	313 000	1 830							
SFD 8020-4			Clearance D					1×4	124 000	417 000	1 230						
DFD 8020-4	Clearance D		1×4					124 000	417 000	2 410							
SFD 10010-6		Clearance D	100					10	6.35	101.75	95.1	1×6	86 200	401 000	1 670		
DFD 10010-6	Clearance D	3 270															
SFD 10012-6		Clearance D		1 680													
DFD 10012-6	Clearance D	3 320															
SFD 10020-4		Clearance D		20	9.525	102.75	93								1×4	136 000	526 000
DFD 10020-4	Clearance D	2 890															

- Notes
1. Nut comes in circular shape I and circular shape II for shaft diameter 20 mm or larger. Select a flange that is suitable for the space available for nut installation.
 2. If there is no seal the nut length "L" is shortened by dimension "M".
 3. The right turn screw is standard. "L" is added to the end of the model code for the left turn screw.

Ball nut dimensions										
Nut entire length <i>L</i>	Nut diameter <i>D</i>	Flanged diameter <i>A</i>	Flanged width <i>B</i>	Notched flange <i>G</i>	Seal dimension <i>M</i>	Bolt hole dimension			Bolt hole PCD <i>W</i>	Oil hole <i>Q</i>
						<i>X</i>	<i>Y</i>	<i>Z</i>		
97	105	151	22	57	10	14	20	13	127	Rc1/8
172										
118										
214	110	156	22	59	12	14	20	13	132	Rc1/8
111										
195										
136										
248										
146										
253	115	173	28	66	20	18	26	17.5	143	Rc1/8
168										
297										
118	125	171	22	64	10	14	20	13	147	Rc1/8
214										
142										
254	130	188	28	71	12	18	26	17.5	158	Rc1/8
172										
301										
172	135	205	32	79	20	22	32	21.5	169	Rc1/8
301										

4. The axial rigidity *K* in the table above is a theoretical value obtained from the elastic deformation between screw groove and ball when the axial load is 30% of the basic dynamic load rating (*C_a*) with non-preload, 10% with D-preload, and 5% with P-preload. Refer to "Technical Description" (page B37) if the axial load and preload differ from the conditions above, or when the deformation of the ball nut body must be considered.
5. It is recommended to use with seals when the shaft diameter is 16 mm or over and an oil hole is provided on the ball nut.
6. Preload system: D; Double nut preload (See page B5.)

B-3-2.4 End Cap Type Ball Screws

1. Features

The end cap recirculation system is suitable for high-helix lead and multiple start threads. Since the leads are 1 to 3 times larger than their screw shaft diameter, it makes them more suitable for high-speed operation.

2. Specifications

(1) Ball recirculation system

The structure of end cap recirculation system is shown in Fig. 1.

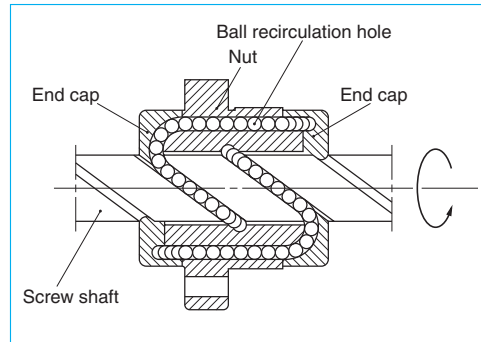

Fig. 1 Structure of end cap recirculation system

(2) Accuracy grade and axial play

The available standard accuracy grade and axial play are shown in Table 1. Please consult NSK for other grades.

Table 1 Accuracy grade and axial play

Accuracy grade	LSFC, LPFC: C1, C2, C3, C5, Ct7 USFC, UPFC: C3, C5, Ct7 (Three times lead or over are C5, Ct7)
Axial play	Z, 0 mm (preloaded); T, 0.005 mm or less; S, 0.020 mm or less; N, 0.050 mm or less

(3) Allowable d·n value and the criterion of maximum rotational speed.

The allowable d·n value and criterion of maximum rotational speed are shown below. Please consult NSK for high-speed specification. Basic measure must be taken for the high speed ball screws respectively.

Allowable d·n value:

Standard specification ; 80 000 or less

High-speed specification; 100 000 or less

Standard of rotational speed : 3 000 min⁻¹

※Please also review the critical speed. Refer to "Technical Description: Permissible Rotational Speed" (page B47) for details.

(4) Other specifications

Please consult NSK for other specifications not listed in the dimension tables.

3. Product categories

There are two different preload systems with several models (Table 2).

Table 2 End cap type ball screws product categories

Nut model	Shape	Flange shape	Nut shape	Preload system
LSFC		Flanged Circular III	Circular	Non-preload, Slight axial play
LPFC			Circular	P-preload (light preload) no spacer ball
USFC		Flanged Rectangular	Circular	Non-preload, Slight axial play
UPFC			Circular	P-preload (light preload) no spacer ball

4. Design Precautions

When designing the screw shaft end, one end of the screw must meet either one of the following conditions. If not, we cannot install the ball nut on the screw shaft.

- Cut the ball groove through to the shaft end.
- The diameters of bearing journals and the gear or pulley seat must be less than the root diameter of ball groove "dr" specified on the dimension table.

Special bearings which have higher-load carrying capacity are available.

For general precautions regarding ball screws, refer to "Design Precautions" (page B83) and "Handling Precautions" (page B103).

5. Example of model number in dimension tables

The followings describe the structure of "Model number" and "Reference number for ball screw".

◇Model number

UPFC 25 25 - 3

Nut model:
LSFC, LPFC,
USFC, UPFC

Screw shaft diameter (mm)

Effective turns of balls

Lead (mm)

◇Reference number for ball screw

W 25 09 - ** P G X - C3 Z 25

Product code

Screw shaft diameter (mm)

Effective threaded length (in the unit of 100 mm)

NSK design serial number

Preload code:
No code, non-preload; P, P-preload (page B5)

Lead (mm)

Axial play code:
Z, T, S, N (page B20)

Accuracy grade code:
C1, C2, C3, C5, C7 (Ct7) (page B37 to B42)

Appearance/specification code

End cap recirculation system

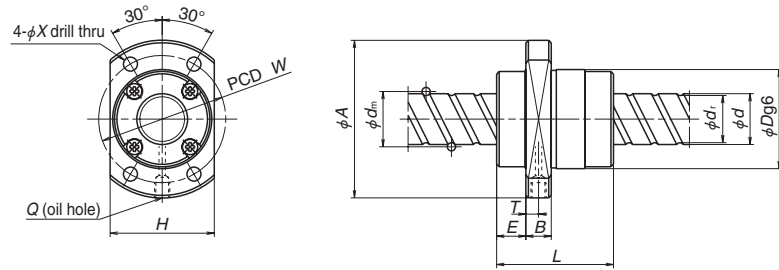

LSFC, LPFC

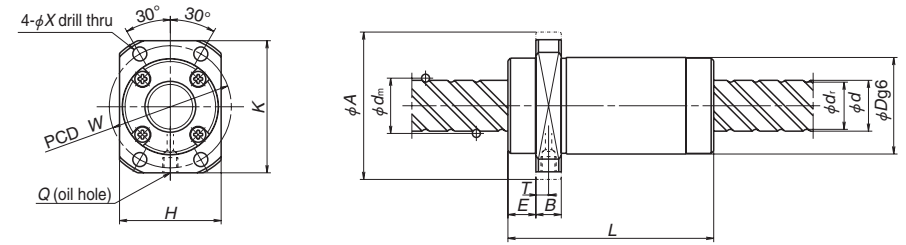

USFC, UPFC

Unit: mm

Model No.	Preload system	Shaft dia. <i>d</i>	Lead <i>l</i>	Ball dia. <i>D_w</i>	Ball circle dia. <i>d_n</i>	Root dia. <i>d_r</i>	Effective turns of balls Turns × Circuits	Basic load rating (N)		Axial rigidity <i>K</i> (N/μm)
								Dynamic <i>C_a</i>	Static <i>C_{0a}</i>	
USFC 1220-1.5	Clearance	12	20	2.381	12.5	9.9	1.7×1	2 690	4 420	66
UPFC 1220-1.5	P									103
USFC 1520-1.5	Clearance	15	20	3.175	15.5	12.2	1.7×1	5 070	8 730	97
UPFC 1520-1.5	P									151
USFC 1540-1	Clearance	15	40	3.175	15.75	12.2	0.7×2	3 860	6 050	62
UPFC 1540-1	P									97
USFC 1540-2	Clearance	15	40	3.175	15.75	12.2	0.7×4	7 000	12 100	121
UPFC 1540-2	P									188
LSFC 1616-3	Clearance	16	16	2.778	16.65	13.7	1.7×2	6 380	12 500	172
LPFC 1616-3	P									268
LSFC 1616-6	Clearance	16	16	2.778	16.65	13.7	1.7×4	11 600	25 000	334
LPFC 1616-6	P									520
USFC 1632-1	Clearance	16	32	3.175	16.75	13.4	0.7×2	4 000	6 690	74
UPFC 1632-1	P									116
USFC 1632-3	Clearance	16	32	3.175	16.75	13.4	1.7×2	8 580	17 000	176
UPFC 1632-3	P									273
USFC 1632-6	Clearance	16	32	3.175	16.75	13.4	1.7×4	15 600	34 100	340
UPFC 1632-6	P									530
USFC 1650-1	Clearance	16	50	3.175	16.75	13.4	0.7×2	4 000	6 690	65
UPFC 1650-1	P									102
USFC 1650-2	Clearance	16	50	3.175	16.75	13.4	0.7×4	7 260	13 400	126
UPFC 1650-2	P									197
LSFC 2020-3	Clearance	20	20	3.175	20.75	17.4	1.7×2	9 620	21 000	238
LPFC 2020-3	P									370
LSFC 2020-6	Clearance	20	20	3.175	20.75	17.4	1.7×4	17 500	42 000	462
LPFC 2020-6	P									718
USFC 2040-1	Clearance	20	40	3.175	20.75	17.4	0.7×2	4 490	8 640	89
UPFC 2040-1	P									138
USFC 2040-3	Clearance	20	40	3.175	20.75	17.4	1.7×2	9 620	21 000	211
UPFC 2040-3	P									328
USFC 2040-6	Clearance	20	40	3.175	20.75	17.4	1.7×4	17 500	42 000	409
UPFC 2040-6	P									636
USFC 2060-1	Clearance	20	60	3.175	20.75	17.4	0.7×2	4 490	8 640	78
UPFC 2060-1	P									121
USFC 2060-2	Clearance	20	60	3.175	20.75	17.4	0.7×4	8 140	17 300	151
UPFC 2060-2	P									235

Nut entire length <i>L</i>	Nut diameter <i>D</i>	Flanged diameter <i>A</i>	Flanged width <i>B</i>	Ball nut dimensions		End cap dimension <i>E</i>	Bolt hole dimension <i>X</i>	Bolt hole PCD <i>W</i>	Oil hole <i>Q</i>	Oil hole position <i>T</i>
				Flanged dimension						
				<i>H</i>	<i>K</i>					
44	26	44	10	28	40	9	4.5	35	M6×1	5
45	34	55	10	36	50	11	5.5	45	M6×1	5
40	32	53	10	33	48	12	5.5	43	M6×1	5
38	32	53	10	34	—	10	4.5	42	M6×1	5
34	34	55	10	36	50	10.5	5.5	45	M6×1	5
34										
66										
66										
50	34	55	10	36	50	12	5.5	45	M6×1	5
46	39	62	10	41	—	11.5	5.5	50	M6×1	5
41	38	58	10	40	52	11	5.5	48	M6×1	5.5
41										
81										
81										
58	38	58	10	40	52	12.3	5.5	48	M6×1	5

Notes: 1. For the LSFC and USFC type ball screws, the axial rigidity *K* in the table above is the theoretical values obtained from the elastic deformation between screw groove and ball when the axial load is 30% of the basic dynamic load rating (*C_a*). For the LPFC and UPFC type, the rigidity is the theoretical value when the preload is 10% of the basic dynamic load rating (*C_a*) and an axial load is applied to it. Refer to the "Technical Description" (page B37) if the rigidity and preload differ from the conditions above, or when the deformation of the ball nut body must be considered.

2. The right turn screw is the standard. Please consult NSK for the left turn screw.
 3. The models marked with * (asterisk) are available in the FA type standard ball screws with finished shaft end.
 4. Preload system: P; Oversize ball preload (See page B5.)

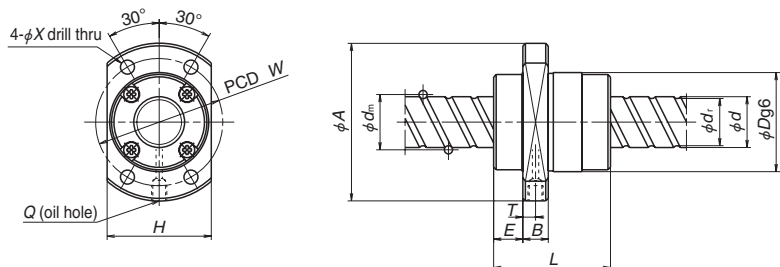

LSFC, LPFC

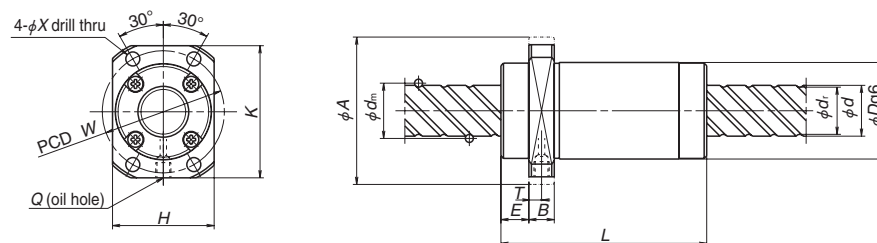

USFC, UPFC

Unit: mm

Model No.	Preload system	Shaft dia. <i>d</i>	Lead <i>l</i>	Ball dia. <i>D_w</i>	Ball circle dia. <i>d_n</i>	Root dia. <i>d_r</i>	Effective turns of balls Turns × Circuits	Basic load rating (N)		Axial rigidity <i>K</i> (N/μm)					
								Dynamic <i>C_a</i>	Static <i>C_{0a}</i>						
LSFC 2525-3	Clearance	25	25	3.969	26.0	21.9	1.7×2	14 400	32 800	293					
LPFC 2525-3	P						1.7×2	14 400	32 800	456					
LSFC 2525-6	Clearance						1.7×4	26 100	65 600	568					
LPFC 2525-6	P						1.7×4	26 100	65 600	883					
USFC 2550-1	Clearance						0.7×2	6 700	13 500	109					
UPFC 2550-1	P						0.7×2	6 700	13 500	170					
USFC 2550-3	Clearance	50	50	3.969	26.0	21.9	1.7×2	14 400	32 800	264					
UPFC 2550-3	P						1.7×2	14 400	32 800	412					
USFC 2550-6	Clearance						1.7×4	26 100	65 600	512					
UPFC 2550-6	P						1.7×4	26 100	65 600	796					
USFC 2580-1	Clearance						80	80	3.969	26.0	21.9	0.7×2	6 700	13 500	94
UPFC 2580-1	P											0.7×2	6 700	13 500	147
USFC 2580-2	Clearance	0.7×4	12 200	27 000	184										
UPFC 2580-2	P	0.7×4	12 200	27 000	285										
LSFC 3232-3	Clearance	32	32	4.762	33.25	28.3						1.7×2	21 000	51 600	366
LPFC 3232-3	P											1.7×2	21 000	51 600	570
LSFC 3232-6	Clearance						1.7×4	38 100	103 000	709					
LPFC 3232-6	P						1.7×4	38 100	103 000	1 104					
USFC 3264-1	Clearance						64	64	4.762	33.25	28.3	0.7×2	9 800	20 900	143
UPFC 3264-1	P											0.7×2	9 800	20 900	222
USFC 3264-3	Clearance	1.7×2	21 000	51 600	329										
UPFC 3264-3	P	1.7×2	21 000	51 600	512										
USFC 3264-6	Clearance	1.7×4	38 100	103 000	636										
UPFC 3264-6	P	1.7×4	38 100	103 000	991										
LSFC 4040-3	Clearance	40	40	6.350	41.75	35.2	1.7×2	33 500	86 500	455					
LPFC 4040-3	P						1.7×2	33 500	86 500	708					
LSFC 4040-6	Clearance						1.7×4	60 800	173 000	880					
LPFC 4040-6	P						1.7×4	60 800	173 000	1 370					
LSFC 5050-3	Clearance						50	50	7.938	52.25	44.1	1.7×2	50 000	135 000	560
LPFC 5050-3	P											1.7×2	50 000	135 000	871
LSFC 5050-6	Clearance	1.7×4	90 800	270 000	1 084										
LPFC 5050-6	P	1.7×4	90 800	270 000	1 688										

Notes: 1. For the LSFC and USFC type ball screws, the axial rigidity *K* in the table above is the theoretical values obtained from the elastic deformation between screw groove and ball when the axial load is 30% of the basic dynamic load rating (*C_a*). For the LPFC and UPFC type, the rigidity is the theoretical value when the preload is 10% of the basic dynamic load rating (*C_a*) and an axial load is applied to it. Refer to the "Technical Description" (page B37) if the rigidity and preload differ from the conditions above, or when the deformation of the ball nut body must be considered.









Nut entire length <i>L</i>	Nut diameter <i>D</i>	Flanged diameter <i>A</i>	Flanged width <i>B</i>	Ball nut dimensions		End cap dimension <i>E</i>	Bolt hole dimension <i>X</i>	Bolt hole PCD <i>W</i>	Oil hole <i>Q</i>	Oil hole position <i>T</i>	
				Flanged dimension							
				<i>H</i>	<i>K</i>						
55	47	74	12	49	—	13	6.6	60	M6×1	6	
50	46	70	12	48	63	13	6.6	58	M6×1	7	
50											
100											
100											
100	75	46	70	12	48	63	14.5	6.6	58	M6×1	6
75											
75											
75											
70	58	92	12	60	—	16	9	74	M6×1	5.5	
62											
62											
126											
126	58	92	12	60	82	15.5	9	74	M6×1	7.5	
126											
126											
126											
85	73	114	15	75	—	19.5	11	93	M6×1	6.5	
85											
85											
85											
107	90	135	20	92	—	21.5	14	112	M6×1	7	
107											
107											
107											



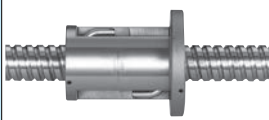

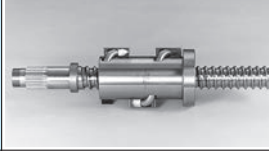

2. The right turn screw is the standard. Please consult NSK for the left turn screw.
 3. The models marked with * (asterisk) are available in the FA type standard ball screws with finished shaft end.
 4. Preload system: P; Oversize ball preload (See page B5.)

1. HMD Type for High-Speed Machine Tools	B495
2. HMS Type for High-Speed Machine Tools	B499
3. HMC Type for High-Speed Machine Tools	B503
4. BSL™ Type for Miniature Lathes	B509
5. For High-Load Drives	
5.1 HTF-SRC Type	B513
5.2 HTF-SRD Type	B517
5.3 HTF Type	B521
6. For Contaminated Environments	
6.1 VSS Type	B533
6.2 Ball Screw with X1 Seals for Contaminated Environments and Grease Retention	B537
7. TW Series for Twin-Drive Systems	B543
8. For High Precision Machine Tools	
8.1 Hollow Shaft Ball Screws	B544
8.2 Nut Cooling Ball Screws	B549
9. ND Series for Nut-Rotatable Drives	B553
10. Σ Series for Robots	B561
11. Ball Screw with L1 Seal designed for Minimal Grease Splatter	B573
12. Equipped with "NSK K1™" Lubrication Unit	B577
13. Special Ball Screws	B583

B-3-3 Dimension Table and Reference Number of Application-Oriented Ball Screws

◆ Features and application examples of application-oriented ball screws

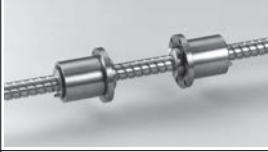
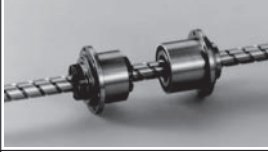
Applications		Shape	Features	Applications	Page
High-Speed Machine Tools	HMD Type		High-speed operation: 64 to 120 m/min Rigidity: 5% greater than the HMC series. High-load carrying capacity: 7% greater than the HMC type New recirculation system reduces the noise level by 5 dB or more compared with the HMC type	High-speed machining centers High-speed combined machine tools Die mold processing machine	B495
	HMS Type		Fine lead: 5 to 12 mm High-speed operation: 25 to 50 m/min Easy replacement: Dimensional interchangeability with tube type ball screws New recirculation system reduces the noise level by 5 dB or more compared with the Tube type.	Machining centers Die mold processing machine NC lathes Combined machine tools	B499
	HMC Type		High-speed: 40 to 120 m/min Rigidity: 30% greater than existing tube type ball screws High-Load carrying capacity: 14% greater than existing tube type ball screws Noise reduced by small-diameter balls	High-speed machining centers High-speed combined machine tools Die mold processing machines	B503
Small Lathes	BSL Type		Compact nut: 50% less ball nut volume than NSK existing products. High-dust protection by thin plastic seal Special high-load capacity ball screw support bearings are available.	Small lathes Multi-axis lathes Small machining centers	B509
High-Load Drives	HTF-SRC Type		High-load capacity High-speed operation by high-speed rotation: 930 mm/sec Even load distribution to balls in the ball nut for high-load drive Improved durability by NSK S1	Injection axis of injection molding machines Servo press machines Press brake Bending machines	B513
	HTF-SRD Type		High-load capacity High-speed operation by large screw lead: 1 600 mm/sec Improved durability by NSK S1	Clamping axis of injection molding machines Die cast machines Punch presses Lifting and lowering devices	B517
	HTF Type		High-load capacity Even load distribution to the balls in a ball nut for high-load drive Improved durability by NSK S1 Provide a wide range of screw diameter and lead combinations.	Injection molding machines Press machines Press fitting machines Lifting and lowering machines	B521
Contaminated Environments	VSS Type		High dust-resistant performance: Reduces particle penetration rate to less than 1/15 (compared with standard seal). More than four times longer service life than standard seal under contaminated environments.	Woodworking machines Laser cutting machines Graphite milling machines Tire molding machines Transfer equipment	B533

Applications		Shape	Features	Applications	Page
Contaminated Environments and Grease Retention	Ball Screw with X1 Seals		Highly dustproof: Particle penetration ratio reduced to less than 1/30 of existing standard seals. Superior grease retention: Can reduce lubricant consumption, also effective at suppressing grease splattering.	Machining centers Combined machine tools NC lathes Woodworking machines Laser cutting machines Graphite milling machines Tire molding machines	B537
Twin-Drive Systems	TW Series		Controlled screw lead accuracy and variation of preload torque for twin drive. Improved axial rigidity, expected life and controllability by the paired up two ball-screw driving systems	Machining centers Combined machine tools Large-size machine tools	B543
High-Precision Machine Tools	Hollow Shaft Ball Screws		Suppress thermal deformation by cooling the shaft center Prevent the machine base from deforming due to thermal expansion. NSK special support units and seal units are available.	High-precision die processing machines High-precision combined machine tools High-precision machining centers High-precision lathes	B544
	Nut Cooling Ball Screws		Due to the simple nut cooling setup, cooling is achieved simply by attaching piping to the thermal displacement control nut. Cooling just as effective as core cooling Insulation to prevent heat from affecting the table.	High-precision die processing machines High-precision combined machine tools High-precision machining centers High-precision lathes Large machine tools	B549
Nut-Rotatable Ball Screws	NDT and NDD Type		Angular contact support bearings are integrated into the ball nut. Two or more ball nuts can be installed in a single ball screw shaft. The NDD type ball screws can surpass the critical speed. A special vibration damper enables long-stroke-high-speed operation.	Woodworking machines Laser cutting machines Electronic component mounting devices Liquid crystal display transfer equipment Transfer equipment	B553
Robots	Σ Series		A ball screw and a ball spline are made in one shaft, combining a drive and guide system. A ball screw nut, a ball spline nut and support bearings are combined to the unit. Hollow shaft has an effect for weight saving. The hollow can be used for wiring and piping.	SCALA type robots Electronic-component mounting systems	B561
Ball Screw with L1 Seal designed for Minimal Grease Splatter			Amount of splattered grease : 1/10 or less (compared with standard seal) Reduced grease-splattering helps maintaining machines and working environment clean. It can be fitted to Compact FA Series and High Speed SS Series later.	Electronic component mounting devices Semiconductor/Liquid crystal display manufacturing equipment Food processing/Medical equipment Transfer equipment	B573
Equipped with "NSK K1" Lubrication Unit			Long-term, maintenance-free operation Maintains lubrication efficiency for a prolonged time in contaminated environments Does not pollute the environment Made of compatible material with the FDA regulations is also available.	Automotive manufacturing machines Woodworking machines Laser cutting machines Semiconductor/Liquid crystal display manufacturing equipment Food processing/Medical equipment	B577

B-3-3.1 HMD Type for High-Speed Machine Tools

This product is being applied for a patent. The newly developed ball recirculation components, the end-deflector and middle-deflector, have greatly contributed for the substantial improvements in the maximum rotational speed and noise level compared to the HMC type.

1. Features

- High speed
The permissible rotational speed (d·n value) has greatly increased to 160 000 compared with 135 000 of the HMC type.
- Low noise
Noise reduced by 5 dB or more compared with the HMC type ball screws for high-speed machine tools.
- Nut mounting dimensions
The ball nut diameters are the same as those of the HMC type.

2. Specifications

(1) Recirculation system

Fig.1 shows the structure of the middle-deflector recirculation system of the HMD type.

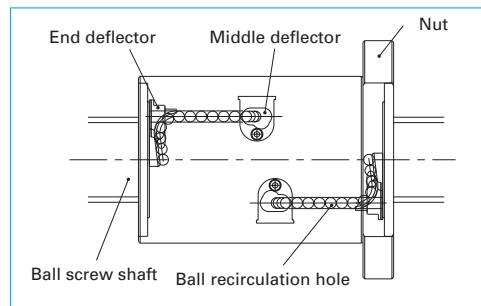

Fig. 1 Structure of middle-deflector recirculation system

(2) Accuracy grade and axial play

The available standard accuracy grade and axial play are as follows. Please consult NSK for other grades.

Table 1 Accuracy grade and axial play

Accuracy grade	C3, C5
Axial play	0 mm (preloaded)

(3) Allowable d·n value and the criterion of maximum rotational speed

Allowable d·n value and the criterion of maximum rotational speed are shown below. Please consult NSK if the rotational speed exceeds the permissible range below.

Allowable d·n value: 160 000 or less
 Criterion of maximum rotational speed : 4 000 min⁻¹

Note: Please also review the critical speed. See "Technical Description: Permissible Rotational Speed" (page B47) for details.

(4) Options

- For twin-drive systems (See page B543.)
Upon request, the variations in lead accuracy and preload torque between two ball screws of a pair of the TW series are controlled for the further improvement of the reliability.
- Hollow shaft ball screw (See page B544.)
- Nut cooling ball screw (See page B549.)

The temperature rise and measures against thermal expansion of ball screw driving mechanism are the most challenging for high-speed machine tools. We recommend using core forced cooling or nut cooling for the HMD type.

(5) Seal

Compact, thin plastic seal is available. Nut outside diameter is compact compare with the return tube recirculation system.

3. Design precautions

For general precautions regarding ball screws, refer to "Design Precautions" (page B83) and "Handling Precautions" (page B103).

4. Product categories

The HMD type has a model as follows.

Table 2 HMD type product categories

Nut model	Shape	Flange shape	Nut shape	Preload system
EM		Flanged Circular II	Circular	Z-Preload (medium preload)

5. Structure of model number and reference number

The followings describe the structure of "Model number" and "Reference number for ball screw".

◇Model number

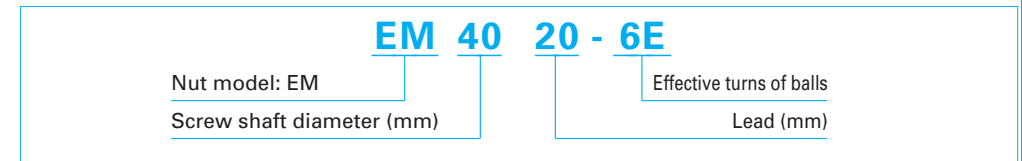

◇Reference number for ball screw

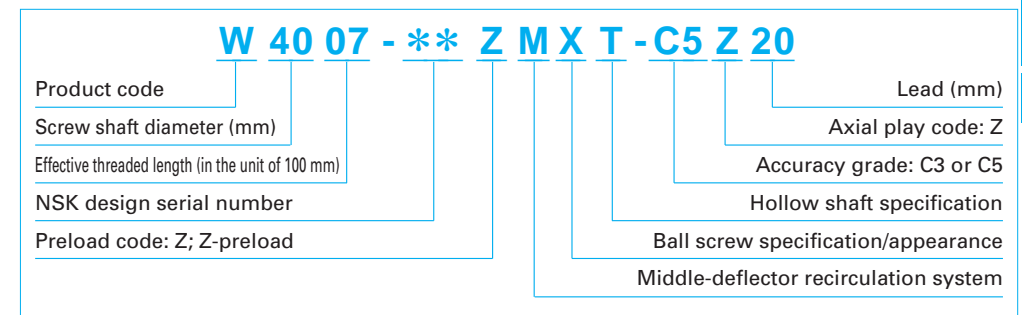

6. Handling Precautions

Maximum operating temperature: 80°C

If using NSK K1, operating temperature should not exceed 50°C. Refer to "Designing Precautions" (page B83).

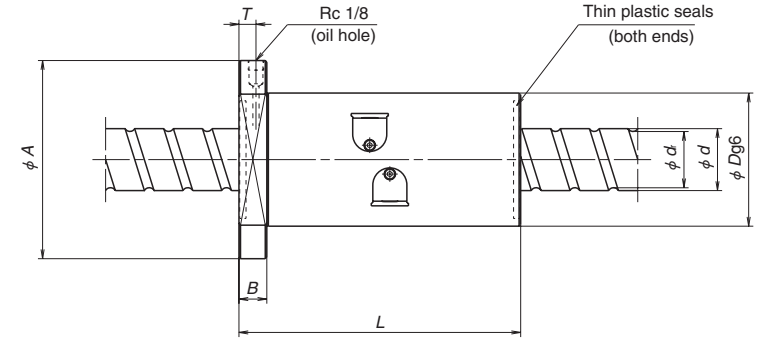
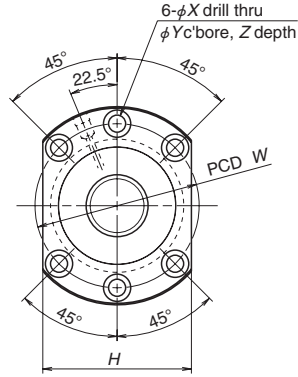

Model No.	Shaft dia. <i>d</i>	Lead <i>l</i>	Root dia. <i>d_r</i>	Basic load rating (N)		Axial rigidity <i>K</i> (N/μm)
				Dynamic <i>C_d</i>	Static <i>C_s</i>	
EM4016-4E	40	16	34.1	57 100	130 000	1 020
EM4020-6E		20	34.4	66 900	165 000	1 340
EM4025-6E		25	34.1	79 100	191 000	1 370
EM4030-6E		30	34.1	79 100	191 000	1 350
EM4516-4E	45	16	39.1	59 600	145 000	1 060
EM4520-6E		20	39.4	69 100	186 000	1 470
EM4525-6E		25	39.1	82 500	213 000	1 510
EM5016-4E	50	16	44.1	61 800	160 000	1 150
EM5020-6E		20	44.4	73 200	206 000	1 600
EM5025-6E		25	44.1	85 600	235 000	1 620
EM5030-6E		30	44.1	85 600	235 000	1 630
EM6316-4E	63	16	55.2	111 000	339 000	1 600

Notes: 1. The right turn screw is the standard. Please consult NSK for left turn screws.
2. Rigidity listed under the column K is the value when a 5% of basic dynamic load rating is applied as the preload.

Ball nut dimensions										Unit: mm	
Nut length <i>L</i>	Nut dia. <i>D</i>	Flange dia. <i>A</i>	Flange width <i>B</i>	Flange size <i>H</i>	Bolt hole size			Bolt hole PCD <i>W</i>	Oil hole position <i>T</i>	Max. feeding speed (m/min)	
					<i>X</i>	<i>Y</i>	<i>Z</i>				
160	86	128	18	96	11	17.5	11	106	11	64	
150										80	
182										100	
213										120	
160	92	134	18	102	11	17.5	11	112	11	56	
150										70	
182										88	
160	98	140	18	107	11	17.5	11	118	11	51	
150										64	
182										80	
213										96	
170	122	180	28	138	18	26	17.5	150	14	40	

B-3-3.2 HMS Type for High-Speed Machine Tools

1. Features

- High speed
The permissible rotational speed (d·n value) has greatly increased to 160 000 compared with 100 000 for tube type screws.
- Low noise
By adopting SRC recirculation system, noise reduced by 5 dB or more compared with tube type screws.
- Nut mounting dimensions
The ball nut diameters are the same as those of tube type screws.

2. Specifications

(1) Recirculation system

Fig.1 shows the structure of the SRC recirculation system of the HMS type.

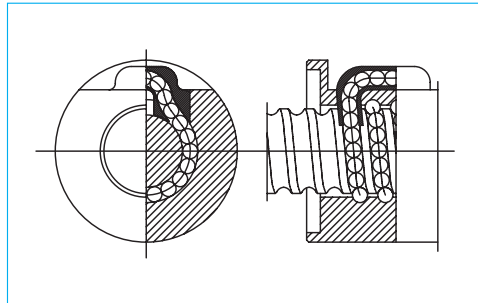

Fig. 1 Structure of SRC recirculation system

(2) Accuracy grade and axial play

The available standard accuracy grade and axial play are as follows. Please consult NSK for other grades.

Table 1 Accuracy grade and axial play

Accuracy grade	C3, C5
Axial play	0 mm (preloaded)

(3) Allowable d·n value and the criterion of maximum rotational speed

Allowable d·n value and the criterion of maximum rotational speed are shown below. Please consult NSK if the rotational speed exceeds the permissible range below.

Allowable d·n value: 160 000 or less
 Criterion of maximum rotational speed : 5 000 min⁻¹

Note: Please also review the critical speed. See "Technical Description: Permissible Rotational Speed" (page B47) for details.

(4) Options

- For twin-drive systems (See page B543.)
Upon request, the variations in lead accuracy and preload torque between two ball screws of a pair of the TW series are controlled for the further improvement of the reliability.
- Hollow shaft ball screw (See page B544.)
- Nut cooling ball screw (See page B549.)

The temperature rise and measures against thermal expansion of ball screw driving mechanism are the most challenging for high-speed machine tools. We recommend using core forced cooling or nut cooling for the HMS type.

3. Design precautions

For general precautions regarding ball screws, refer to "Design Precautions" (page B83) and "Handling Precautions" (page B103).

4. Product categories

The HMS type has a model as follows.

Table 2 HMS type product categories

Nut model	Shape	Flange shape	Nut shape	Preload system
ZFRC		Flanged Circular II	Circular	Z-Preload (medium preload)

5. Structure of model number and reference number

The followings describe the structure of "Model number" and "Reference number for ball screw".

◇Model number

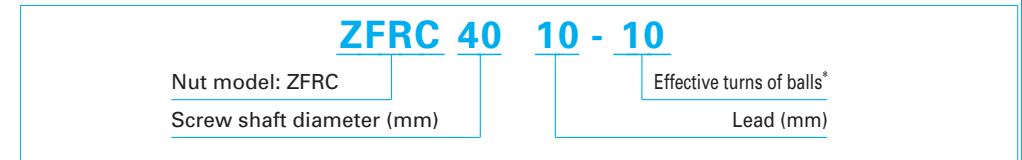

* In the case of Z-preload, the amount shown is twice the effective turn of balls.

◇Reference number for ball screw

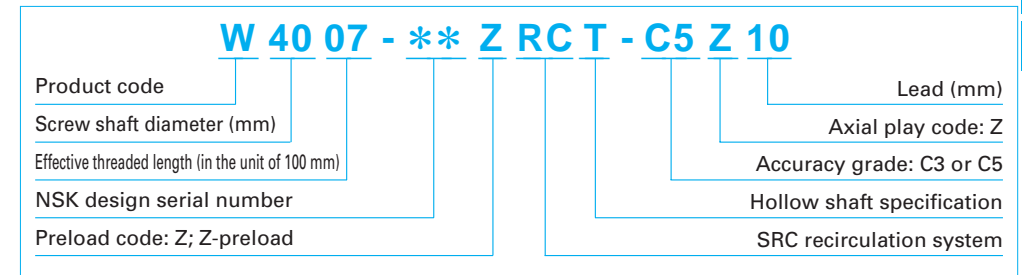

6. Handling Precautions

Maximum operating temperature: 60°C
 If using NSK K1, operating temperature should not exceed 50°C. Refer to "Designing Precautions" (page B83).

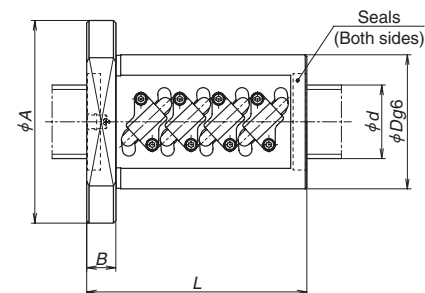
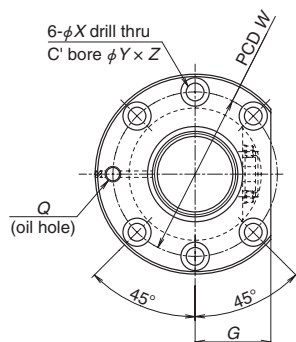

Model No.	Shaft dia. <i>d</i>	Lead <i>l</i>	Root dia. <i>d_r</i>	Effective turns Turns × rows	Basic load rating (N)		Axial rigidity <i>K</i> (N/μm)
					Dynamic <i>C_e</i>	Static <i>C_{0e}</i>	
ZFRC3205-10	32	5	29.2	2.5×2	18 500	56 100	840
ZFRC3210-10	32	10	26.4	2.5×2	46 300	108 000	920
ZFRC4005-10	40	5	37.2	2.5×2	20 200	70 600	1 120
ZFRC4010-10	40	10	34.4	2.5×2	52 000	137 000	1 090
ZFRC4012-10	40	12	34.1	2.5×2	61 000	155 000	1 110
ZFRC4508-10	45	8	40.5	2.5×2	37 300	118 000	1 160
ZFRC4510-10	45	10	39.4	2.5×2	54 200	155 000	1 210
ZFRC4512-10	45	12	39.1	2.5×2	64 200	177 000	1 230
ZFRC5010-10	50	10	44.4	2.5×2	57 700	175 000	1 320
ZFRC5012-10	50	12	43.2	2.5×2	77 600	214 000	1 360
ZFRC6312-14	63	12	56.2	3.5×2	115 000	386 000	2 250

Notes: 1. The right turn screw is the standard. Please consult NSK for left turn screws.
 2. Rigidity listed under the column K is the value when a 5% of basic dynamic load rating is applied as the preload.

Unit: mm

Nut length <i>L</i>	Nut dia. <i>D</i>	Flange dia. <i>A</i>	Flange width <i>B</i>	Groove size <i>G</i>	Bolt hole size			Bolt hole PCD <i>W</i>	Oil hole position <i>Q</i>	Max. feeding speed (m/min)
					<i>X</i>	<i>Y</i>	<i>Z</i>			
89	58	85	12	32	6.6	11	6.5	71	M6×1	25
163	74	108	15	41	9	14	8.5	90	M6×1	50
92	67	101	15	39	9	14	8.5	83	M6×1	25
166	82	124	18	47	11	17.5	11	102	Rc1/8	40
192	86	128	18	48	11	17.5	11	106	Rc1/8	48
136	82	124	18	47	11	17.5	11	102	Rc1/8	28
166	88	132	18	50	11	17.5	11	110	Rc1/8	35
192	90	132	18	50	11	17.5	11	110	Rc1/8	42
166	93	135	18	51	11	17.5	11	113	Rc1/8	32
198	100	146	22	55	14	20	13	122	Rc1/8	38
244	115	161	22	61	14	20	13	137	Rc1/8	30

HMS

B-3-3.3 HMC Type for High-Speed Machine Tools

This product is being applied for a patent.

1. Features

- High-speed traveling
High helix leads of 16 mm to 36 mm are used. Furthermore, the ball recirculation return tube is reinforced to make a high-speed traveling of 40 to 120 m/min. possible.
- High rigidity, high load carrying capacity
Double start thread increases the number of effective turns of balls, and a smaller ball size increases the number of the balls. Together they contribute to have high rigidity and high load carrying capacity, despite the high helix lead.
- Compact nut
The size of nut diameter and length were reduced.

2. Specifications

(1) Ball recirculation system

The ball recirculation circuits and grooves are suited for high-speed operation. Structure of recirculation system is shown in Fig. 1.

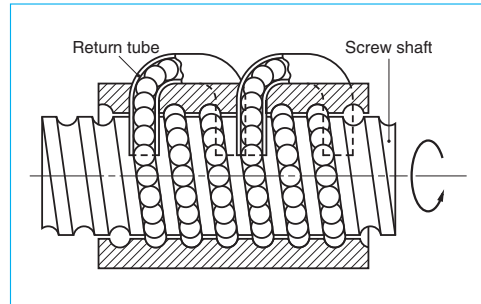

Fig. 1 Structure of return tube recirculation system

(2) Accuracy grades and axial play

Standard accuracy grades and axial play are shown in Table 1. Please consult NSK for other grade.

Accuracy grade	C3, C5
Axial play	0 mm (preloaded)

(3) Options

- Equipped with NSK K1 lubrication unit
Optional NSK K1 lubrication unit, molded from

resin and impregnated with lubrication oil, is available. Please consult NSK when using NSK K1.

- For twin-drive systems (See page B543.)
Upon request, the variations in lead accuracy and preload torque between two ball screws of a pair of the TW series are controlled for the further improvement of the reliability.
- Hollow shaft ball screw specifications (See page B544.)

The temperature rise and measures against thermal expansion of ball screw driving mechanism are the most challenging for high-speed machine tools. For the HMD type ball screws, we recommend to utilize the hollow for forced cooling system.

- For a vertical axis ball screw
For a vertical axis ball screw, which constantly supports the load of vertical axis system, a high load capacity ball screw is required. A high load capacity type with compact design is available for the nut models II and III in the dimension tables. For details, please consult NSK.

(4) Allowable d·n value and the criterion of maximum rotational speed

Allowable d·n value and the criterion of maximum rotational speed are shown below. Please consult NSK if the rotational speed exceeds the permissible range below.

Allowable d·n value: HZC, HDC; 100 000 or less
HZF, HDF; 135 000 or less

Criterion of maximum rotational speed: 3 750 min⁻¹
Note: Please also review the critical speed. See "Technical Description: Permissible Rotational Speed" (page B47) for details.

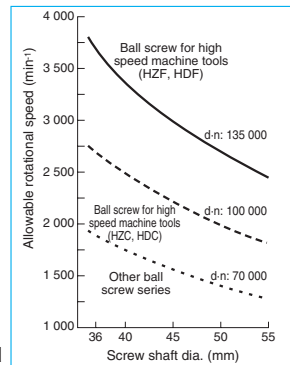

Fig. 2 Comparison of permissible rotational speed

(5) Other specifications

For other specifications not listed in the dimension tables such as high-speed, high-load capacity, and NSK K1 installed type, please consult NSK.

3. Design precautions

For general precautions regarding ball screws, refer to "Design Precautions" (page B83) and "Handling Precautions" (page B103).

4. Product categories

HMC type has two different preload systems with several models (Table 2).

Table 2 HMC type product categories

Nut model	Shape	Flange shape	Preload system
HZC HZF		Flanged Circular I	Z-preload (medium preload)
HDC HDF		Flanged Circular I	D-preload (medium preload)

5. Structure of model number and reference number

The followings describe the structure of "Model number" and "Reference number for ball screw".

◇Model number

HZF 36 16 - 5

Nut model: HZC, HZF, HDC, HDF Effective turns of balls
Screw shaft diameter (mm) Lead (mm)

◇Reference number for ball screw

W 36 05 - ** Z X T - C5 Z 16

Product code Lead (mm)
Screw shaft diameter (mm) Axial play code: Z (page B20)
Effective threaded length (in the unit of 100 mm) Accuracy grade: C3, C5 (page B37 to B42)
Design serial number Hollow shaft ball screw
Preload code : Z, Z-preload; D, D-preload (page B5) Appearance/specification code

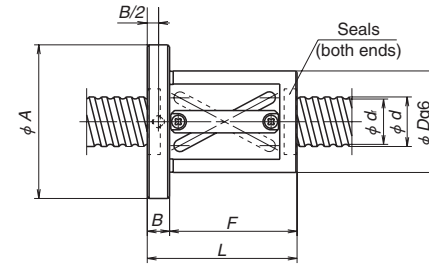
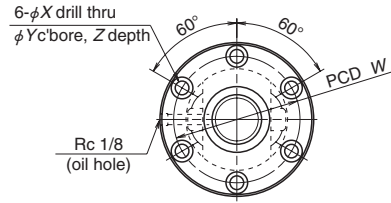

Nut model I (offset preload)

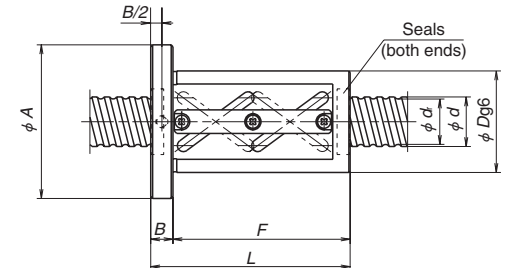

Nut model II (offset preload)

Unit: mm

Model No.	Shaft dia. <i>d</i>	Lead <i>l</i>	Root dia. <i>d_r</i>	Effective turns of balls	Nut model	Basic load rating (N)		Axial rigidity <i>K</i> (N/μm)	
						Dynamic <i>C_a</i>	Static <i>C_{0a}</i>	5% <i>C_a</i>	10% <i>C_a</i>
HZF3616-5 HZC3616-5	36	16	31.5	5	II	40 200	102 000	1 130	1 420
HZF3620-3.5 HZC3620-3.5		20	30.4	3.5	I	44 000	98 500	830	1 050
HZF4016-5 HZC4016-5	40	16	35.5	5	II	41 200	112 000	1 230	1 550
HZF4020-3.5 HZC4020-3.5		20	34.4	3.5	I	46 100	107 000	900	1 130
HZF4020-5 HZC4020-5				5	II	62 600	153 000	1 260	1 590
HZF4516-5 HZC4516-7.5		45	16	40.5	5	II	43 800	127 000	1 340
HZF4520-3.5 HZC4520-3.5	20				39.4	3.5	I	47 600	120 000
HZF4520-5 HZC4520-5			5	II		64 700	170 000	1 380	1 740
HZF4525-3.5 HZC4525-3.5			25	39.1		3.5	I	56 800	137 000
HZF5020-3.5 HZC5020-3.5	50		20	44.4	3.5	I	50 400	133 000	1 080
HZF5020-5 HZC5020-5		5			II	68 500	191 000	1 520	1 910
HZF5025-3.5 HZC5025-3.5		25	44.1	3.5	I	58 900	152 000	1 100	1 390
HZF5025-5 HZC5025-5				5	II	80 100	216 000	1 540	1 940
HZF5030-3.5 HZC5030-3.5		30	44.1	3.5	I	58 900	152 000	1 100	1 390
HZF5520-3.5 HZF5520-5		55	20	49.4	3.5	I	51 600	145 000	1 150
HZF5525-3.5 HZF5525-5	25				49.1	3.5	I	62 600	165 000
HZF5530-3.5			30	49.1		5	II	85 000	238 000
HZF5530-3.5	30				49.1	3.5	I	62 600	165 000

Notes: 1. Ball screws of 32 or 36 mm lead have triple start threads. Others have double start threads.
2. Rigidity listed under the column 5%Ca is the value when a 5% of basic dynamic load rating is applied as the preload. Similarly, those listed under the column 10%Ca means a 10% of basic dynamic load rating is applied.

Nut entire length <i>L</i>	Ball nut dimensions								Max. feeding speed (m/min)
	Nut dia. <i>D</i>	Flange dia. <i>A</i>	Flange width <i>B</i>	Nut length <i>F</i>	Bolt hole dimensions			Bolt hole PCD <i>W</i>	
					<i>X</i>	<i>Y</i>	<i>Z</i>		
134	78 71	120 113	18	116	11	17.5	11	98 91	60 44
121	94 78	136 120	18	103	11	17.5	11	114 98	75 56
134	79 76	121 118	18	116	11	17.5	11	99 96	54 40
121	96 82	138 124	18	103	11	17.5	11	116 102	67 50
161	96 82	138 124						143	116 102
134 187	82	124 128	18 22	116 165	11 14	17.5 20	11 13	102 104	48
122	98 88	140 130	18	104	11	17.5	11	118 108	60 44
162	98 88	140 130						144	118 108
141	101 92	143 134	18	123	11	17.5	11	121 112	75 56
122	101 95	143 137	18	104	11	17.5	11	121 115	54 40
162	101 95	143 137						144	121 115
141	103 98	145 140	18	123	11	17.5	11	123 118	67 50
191	103 98	145 140						173	123 118
159	103 98	145 140	18	141	11	17.5	11	123 118	81 60
122 162	103	145	18	104 144	11	17.5	11	123	49
141 191	105	147	18	123 173	11	17.5	11	125	61
159	105	147	18	141	11	17.5	11	125	73

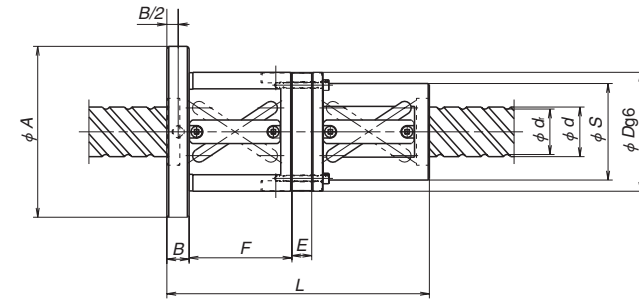
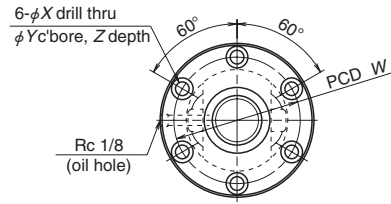

Nut model III (double nut spacer, preload)
(the figure indicates use of double start threads)

Model No.	Shaft dia. <i>d</i>	Lead <i>l</i>	Root dia. <i>d_r</i>	Effective turns of balls	Nut model	Basic load rating (N)		Axial rigidity <i>K</i> (N/μm)	
						Dynamic <i>C_s</i>	Static <i>C_{0s}</i>	5% <i>C_s</i>	10% <i>C_s</i>
						HDF3620-5 HDC3620-5	36	20	30.4
HDF4025-5 HDC4025-5	40	25	34.1	5	III	74 000	175 000	1 320	1 660
HDF4030-5 HDC4030-5		30	34.1	5	III	74 000	175 000	1 320	1 660
HDF4032-7.5 HDC4032-7.5		32	34.4	7.5	III	88 700	230 000	1 920	2 420
HDF4036-4.5		36	34.4	4.5	III	57 200	138 000	1 170	1 480
HDF4525-5 HDC4525-5		25	39.1	5	III	77 200	197 000	1 430	1 800
HDF4530-5 HDC4530-5	45	30	39.1	5	III	77 200	197 000	1 430	1 800
HDF4532-7.5 HDC4532-7.5		32	39.4	7.5	III	91 700	256 000	2 090	2 630
HDF4536-4.5		36	39.4	4.5	III	59 100	155 000	1 280	1 620
HDF5030-5 HDC5030-5		50	30	44.1	5	III	80 100	216 000	1 540
HDF5032-7.5 HDC5032-7.5	32		44.4	7.5	III	97 100	286 000	2 270	2 860
HDF5530-5	55	30	49.1	5	III	85 000	238 000	1 680	2 120
HDF5532-7.5		32	49.4	7.5	III	99 500	313 000	2 420	3 050

Notes: 1. Ball screws of 32 or 36 mm lead have triple start threads. Others have double start threads.
2. Rigidity listed under the column 5%Ca is the value when a 5% of basic dynamic load rating is applied as the preload. Similarly, those listed under the column 10%Ca means a 10% of basic dynamic load rating is applied.

Unit: mm

Nut entire length <i>L</i>	Ball nut dimensions										Max. feeding speed (m/min)
	Nut dia.		Flange dia. <i>A</i>	Flange width <i>B</i>	Nut length <i>F</i>	Spacer dimensions <i>E</i>	Bolt hole size			Bolt hole PCD <i>W</i>	
	<i>D</i>	<i>S</i>					<i>X</i>	<i>Y</i>	<i>Z</i>		
191	94	76	136	18	77	5	11	17.5	11	114	75
	78	60	120								98
228.5	98	80	140	18	91	13.5	11	17.5	11	118	84
	86	68	128								106
248	98	80	140	18	104	8	11	17.5	11	118	101
	86	68	128								106
265	96	78	142	22	109	11	14	20	13	118	108
	82	64	128								106
200	96	78	138	18	83	4	11	17.5	11	116	120
	101	83	143								121
228.5	92	74	134	18	91	13.5	11	17.5	11	112	56
	101	83	143								121
248	92	74	134	18	104	8	11	17.5	11	112	67
	98	80	144								120
266	88	70	134	22	109	11	14	20	13	110	71
	98	80	140								118
200	103	85	145	18	104	8	11	17.5	11	123	81
	98	80	140								118
266	101	83	147	22	109	11	14	20	13	123	86
	95	77	141								117
249	105	87	147	18	104	8	11	17.5	11	125	73
	103	85	149								125

B-3-3.4 BSL™ Type for Miniature Lathes

1. Features

- Prompt delivery
Screw shaft configuration and ball nut shape are standardized for prompt delivery.
- High speed and low noise
Adoption of end-deflector recirculation system realized high-speed operation with low noise.
- Excellent dust resistance
Thin plastic seal and specially designed ball grooves prevent the entry of foreign matters.

2. Specifications

(1) Ball recirculation system

End-deflector recirculation system has features of high-speed, low-noise operation and compact ball nut. The structure of recirculation system is shown in Fig.1.

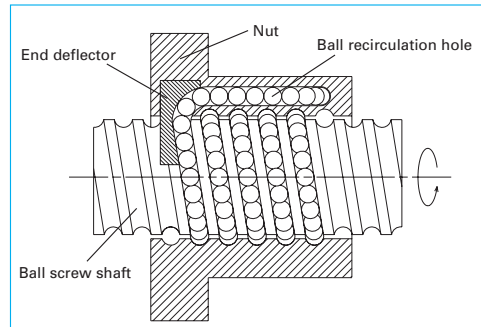

Fig. 1 Structure of end-deflector recirculation system

(2) Accuracy grade and axial play

The available standard accuracy grade and axial play are as follows. Please consult NSK for other grades.

Table 1 Accuracy grade and axial play

Accuracy grade	C5
Axial play	0 mm (preloaded)

(3) Allowable d·n value and the criterion of maximum rotational speed

Allowable d·n value and the criterion of maximum rotational speed are shown below. Please consult NSK if the rotational speed exceeds the permissible range below.

Allowable d·n value: 180 000 or less
 Criterion of maximum rotational speed : 4 000 min⁻¹

Note: Please also review the critical speed. See "Technical Description: Permissible Rotational Speed" (page B47) for details.

(4) Options

Optional NSK K1 lubrication unit, molded from resin and impregnated with lubrication oil, supplies fresh oil onto ball rolling surface, ensuring long-term, maintenance-free operation. Please consult NSK when using NSK K1.

3. Design Precautions

When designing the screw shaft end, one end of the shaft must meet either one of the following conditions. If not, we cannot install the ball nut on the screw shaft.

- Cut the ball groove through to the shaft end.
- The diameters of bearing journals and the gear or pulley seat must be less than the root diameter of ball groove "dr" specified on the dimension table.

Special bearings which have higher-load carrying capacity are available.

For general precautions regarding ball screws, refer to "Design Precautions" (page B83) and "Handling Precautions" (page B103).

4. Product categories

The BSL type has a model as follows.

Table 2 BSL type product categories

Nut model	Shape	Flange shape	Preload system
BSL		Circular III	P-Preload (Slight preload)

5. Structure of model number and reference number

The followings describe the structure of "Model number" and "Reference number for ball screw".

◇Model number

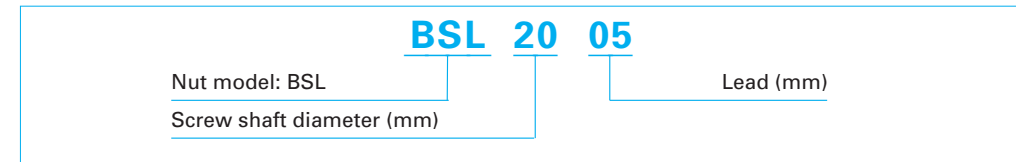

◇Reference number for ball screw

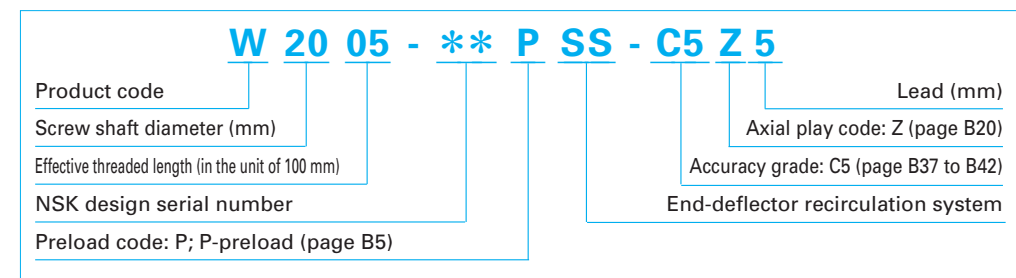

6. Handling Precautions

Maximum operating temperature: 80°C

If using NSK K1, operating temperature should not exceed 50°C. Refer to "Designing Precautions" (page B83).

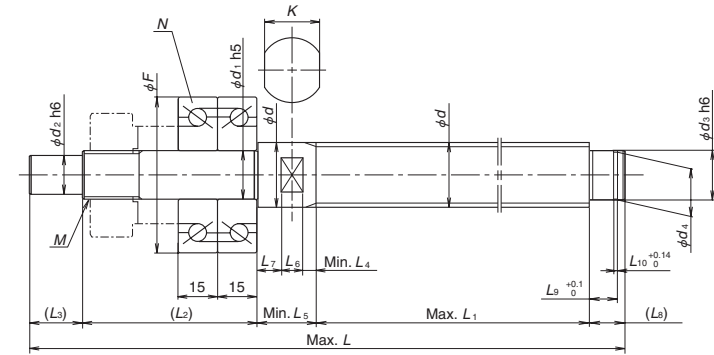
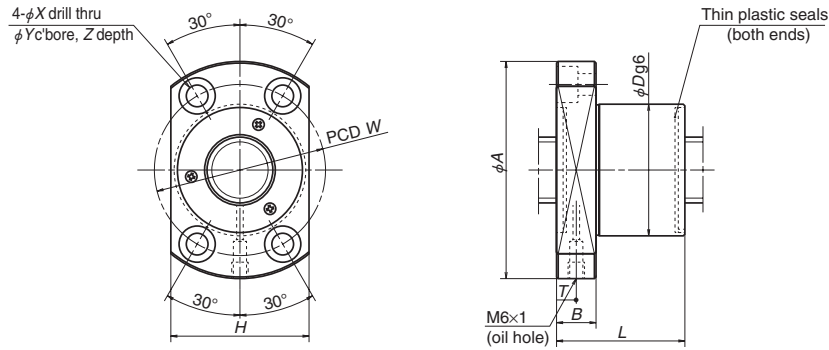

Model No.	Shaft dia. <i>d</i>	Lead <i>l</i>	Root dia. <i>d_r</i>	Basic load rating (N)		Ball nut dimensions										Oil hole <i>d_i</i>
				Dynamic <i>C_d</i>	Static <i>C_{0s}</i>	External dimensions					Bolt hole dimensions					
						<i>D</i>	<i>A</i>	<i>H</i>	<i>B</i>	<i>L</i>	<i>W</i>	<i>X</i>	<i>Y</i>	<i>Z</i>	<i>T</i>	
BSL2005	20	5	17.2	8 920	16 300	36	63	38	12	37	49	6.6	11	6.5	6.5	15
BSL2006		6	16.4	11 900	20 000	40	65	42	12	45	51	6.6	11	6.5	6.7	
BSL2505	25	5	22.2	9 900	20 500	40	65	42	12	38	51	6.6	11	6.5	7.1	20
BSL2506		6	21.4	13 300	25 200	43	69	45	12	44	55	6.6	11	6.5	6.3	
BSL2508		8	20.5	17 100	30 100	46	72	48	12	55	58	6.6	11	6.5	6.5	
BSL2510	10	20.5	17 100	30 100	46	72	48	12	65	58	6.6	11	6.5	6		
BSL3210	32	10	26.4	27 700	51 300	61	93	63	18	68	76	9	14	8.5	10	25
BSL3212		12								77						

Notes: 1. The right turn screw is the standard. Please consult NSK for left turn screw.
2. Shaft dimensions are for reference.

Unit: mm

Shaft configuration and dimensions (reference)																				Exclusive bearing N Bearing reference number	Basic dynamic load rating <i>C_d</i>	Permissible axial load (N)
Shaft dimension															<i>F</i>							
<i>d₂</i>	<i>d₃</i>	<i>d₄</i>	<i>L</i> (max.)	<i>L₁</i> (max.)	<i>L₂</i>	<i>L₃</i>	<i>L₄</i> (min.)	<i>L₅</i> (min.)	<i>L₆</i>	<i>L₇</i>	<i>L₈</i>	<i>L₉</i>	<i>L₁₀</i>	<i>K</i>		<i>M</i>	20TAC47C	47	21 900	26 600		
12	15	14.3 ^{0/-0.11}	500	500	66	20	3	20	4	21	8	9	14	10.15	1.15	17					M15×1.0	
15	20	19 ^{0/-0.21}	700	700	71	27	3	27	4	28	10	14	19	15.35	1.35	22	M20×1.0	20TAC62C	62	28 500	40 500	
							4	28	5	29												
							5	29														
20	25	23.9 ^{0/-0.21}	1 000	800	71	33	6	33	7	34	12	15	20	16.35	1.35	27	M25×1.5	25TAC62C	62	28 500	40 500	

3. Shaft length *L₁* and shaft entire length *L* are the maximum length.
When *L* becomes the same length as the *L₁*, the thread is all screw specification.

B-3-3.5.1 HTF-SRC Type for High-Load Drives

1. Features

● High-speed operation and low noise
 The SRC recirculation system contributes to more than twice the feed speed (d·n value: 140 000 and 160 000) and the noise level of less than 8 to 10 dB (half to 1/3 of noise) compared with the HTF type.

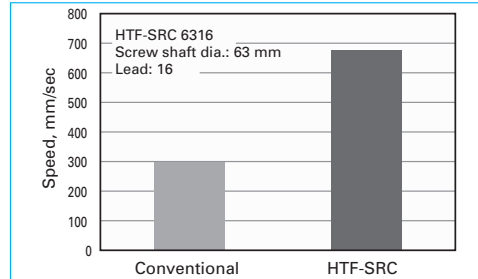

Fig. 1 Feed speed comparison

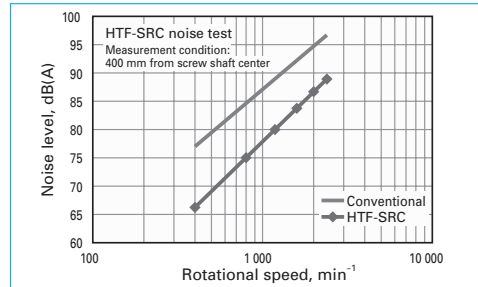

Fig. 2 Noise level comparison

2. Specifications

(1) Ball recirculation system

The SRC recirculation system picks up balls in the direction they are moving, and thus contributed to high-speed, low-noise operation. Structure of the recirculation system is as follows.

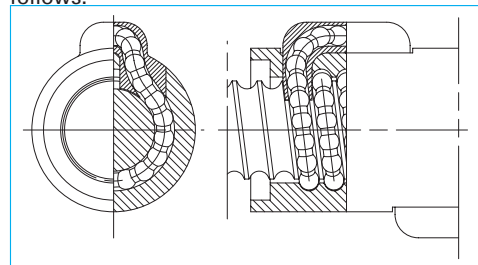

Fig. 3 Structure of SRC recirculation system

(2) Accuracy grade and axial play

The available standard accuracy grade and axial play are as follows. Please consult NSK for other grades.

Table 1 Accuracy grade and axial play

Accuracy grade	Ct7
Axial play	S,0.020 mm or less; N,0.050 mm or less

(3) Allowable d·n value and the criterion of maximum rotational speed

Allowable d·n value and the criterion of maximum rotational speed are shown below. Please consult NSK if the rotational speed exceeds the permissible range below.

Table 2 Allowable d·n value and the criterion of maximum rotational speed

Lead	14, 16 mm	20, 25 mm*
Allowable d·n value	160 000 or less	140 000 or less
Criterion of maximum rotational speed	3 225 min ⁻¹	

d·n value: shaft dia. d [mm] × rotational speed n [min⁻¹]
 ☆ Allowable d · n value for HTF-SRC5020: 160 000

Note: Please also review the critical speed. See "Technical Description: Permissible Rotational Speed" (page B47) for details.

(4) Ball retaining piece NSK S1™

The NSK S1, resin retainers between the balls, significantly extend ball screw durability to the moment load.

(5) Other

Please consult NSK for special requests, such as the addition of a recirculation circuit to increase the load capacity, or the arrangement of all recirculation circuits on the same phase of ball nut circumference.

3. Design Precautions

The HTF-SRC type is designed to distribute the load uniformly to the load balls for high-load drive mechanism. We recommend installing the ball screws in the way shown below for the full use of this characteristic.

In addition, we will make full analysis when you use the HTF-SRC type under extreme conditions such as application of extremely high load or operating in short stroke. Contact NSK about operating conditions (See page B531).

When designing the screw shaft end, one end

of the screw shaft must meet either one of the following conditions. If not, we cannot install the ball nut on the screw shaft.

- Cut the ball groove through to the shaft end.
- The diameters of bearing journals and the gear or pulley seat must be less than the root diameter of ball groove "dr" specified on the dimension table.

For general precautions regarding ball screws, refer to "Design Precautions" (page B83) and "Handling Precautions" (page B103).

4. Product categories

The HTF-SRC type has a model as follows.

Table 3 HTF-SRC type product categories

Nut model	Shape	Flange shape	Preload system
HTF-SRC		Flanged Circular I	Non-preload Slight axial play

5. Structure of model number and reference number

The followings describe the structure of "Model number" and "Reference number for ball screw".

◇Model number

HTF-SRC 63 20 - 7.5

Nut model: HTF-SRC	Screw shaft diameter (mm)	Effective turns of balls	Lead (mm)
--------------------	---------------------------	--------------------------	-----------

◇Reference number for ball screw

W 63 04 - ** RC SP - C7 S 20

Product code	Screw shaft diameter (mm)	Effective threaded length (in the unit of 100 mm)	NSK design serial number	SRC recirculation system	Lead (mm)	Axial play code: S, N (page B20)	Accuracy grade: C7 (Ct7) (page B37 to B42)	Ball retaining pieces NSK S1 specification
--------------	---------------------------	---	--------------------------	--------------------------	-----------	----------------------------------	--	--

6. Handling Precautions

Maximum operating temperature: 70°C (at outside diameter of ball nut)

The lubricant deteriorates, operating temperature

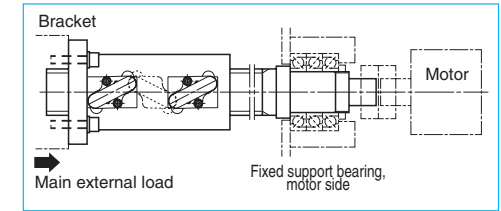
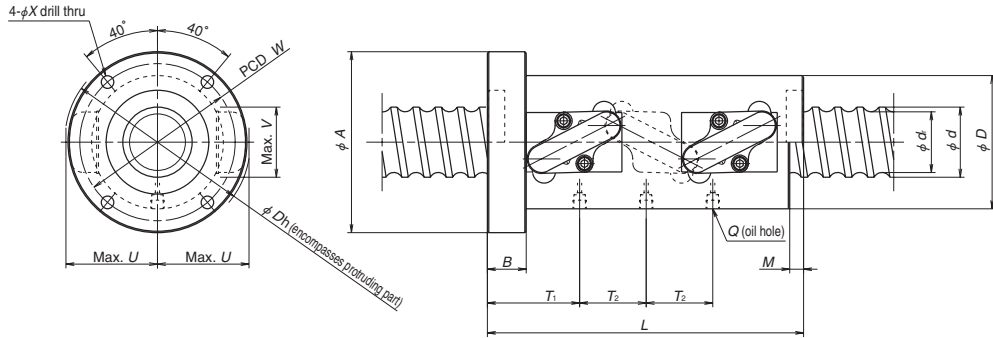

Fig. 4 Recommended installing direction of high-load drive ball screw

is recommended 60°C and under.

Please consult NSK in the case of a short stroke operation less than or equal to four times the length of the ball screw lead.



Nut model I

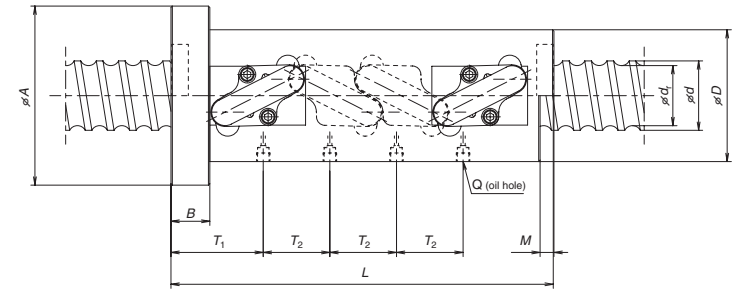

Nut model II

Unit: mm

Model No.	Shaft dia. <i>d</i>	Lead <i>l</i>	Root dia. <i>d_r</i>	Effective turns of balls Turns × Circuits	Nut model	Basic load rating (kN)		Allowable axial load (kN)
						Dynamic <i>C_a</i>	Static <i>C_{0a}</i>	
HTF-SRC5014-7.5	50	14	41.6	2.5×3	I	264	623	73.1
HTF-SRC5016-7.5		16	39	2.5×3		383	818	91.1
HTF-SRC5020-7.5		20	39	2.5×3		383	818	91.0
HTF-SRC6316-7.5	63	16	52	2.5×3	I	429	1 050	119
HTF-SRC6316-10				2.5×4	II	549	1 410	159
HTF-SRC6316-10.5				3.5×3	I	562	1 450	167
HTF-SRC6316-14		3.5×4	II	720	1 930	215		
HTF-SRC6320-7.5		20	49	2.5×3	I	572	1 280	147
HTF-SRC6320-10					2.5×4	II	732	1 710
HTF-SRC6325-10.5	25	49	3.5×3	I	750	1 770	170	
HTF-SRC8016-10.5	80	16	69	3.5×3	I	627	1 870	221
HTF-SRC8016-14				3.5×4	II	802	2 490	295
HTF-SRC8020-10.5		20	66	3.5×3	I	838	2 300	267
HTF-SRC8025-7.5					2.5×3	I	790	1 960
HTF-SRC10020-10.5	100	20	86	3.5×3	I	936	2 910	346
HTF-SRC10020-14				3.5×4	II	1 200	3 890	461
HTF-SRC10025-10.5		25	83	3.5×3	I	1 200	3 430	408
HTF-SRC10025-14					3.5×4	II	1 540	4 580
HTF-SRC12020-7.5	120	20	106	2.5×3	I	776	2 550	304
HTF-SRC12020-10				2.5×4	II	994	3 400	406
HTF-SRC12025-10.5		25	103	3.5×3	I	1 300	4 200	498
HTF-SRC12025-14					3.5×4	II	1 660	5 600

- Notes: 1. The right hand screw is the standard. For specifications on left hand screws, contact NSK.
 2. The ball nut length with no seals is shorter by M than that length of a ball nut with seals.
 3. Please consult NSK if load exceeds the allowable axial load.
 4. The allowable axial load is determined in accordance with the mounting conditions of ball screws recommended by NSK (See page B514). If your mounting conditions differ from those provided, please consult NSK.

Ball nut dimensions											Oil hole		Oil hole position <i>T₁</i> <i>T₂</i>	Max. feeding speed (mm/sec)	
Nut length <i>L</i>	Nut dia. <i>D</i>	Flange dia. <i>A</i>	Flange width <i>B</i>	Seal width <i>M</i>	Bolt hole PCD <i>W</i>	Bolt hole size <i>X</i>	Protruding tube dimensions <i>U</i> <i>V</i> <i>Dh</i>			<i>Q</i>					
202	80	114	28	10	97	9	54.5	46	111	M6×1	69	42	750		
228	95	129					66	50	134	Rc1/8	74.5	48	860		
268	95	129					66	50	134	Rc1/8	83.5	60	1 070		
228	105	139					28	10	122	9	72.5	50	148	Rc1/8	74.5
276			48												
276			64												
340			64												
279			117	157	32	12									
339	101.75	100					930								
405	101.75	100					930								
278	120	154	32	10	137	9	80	60	165	Rc1/8	78.5	64	540		
342												64			
339												90		80	590
347												111.75		75	730
339	145	185	32	12	165	11	97	78	199	Rc1/8	90	80	470		
419												80			
422												111.75		100	590
522	159	199	40	17	179	11	108	79	220	Rc1/8	111.75	100	590		
287	173	213	40	12	193	11	109.5	88	229	Rc1/8	98	60	390		
347												60			
421												111.25		100	490
521												111.25		100	490

HTF-SRC

B-3-3.5.2 HTF-SRD Type for High-Load Drives

This product is being applied for a patent.

1. Features

- High-speed operation and low noise
Used with end deflectors, HTF-SRD type ball screws achieve the maximum feed speed of 1 600 mm/s. The ball nut body surface is completely round, thus enabling well balanced ball nut rotation.
- Double start thread structure which has more recirculation circuits, and large diameter balls contribute to have high load carrying capacity.
- Low noise and compact design
End deflector system using a ball scooping mechanism in the direction of screw spiral offers smoother ball recirculation system, thus contributing to less than half the noise level compared with existing ball screws equipped with a return tube. Compact, high-performance seal is available. Nut outside diameter is compact compare with the return tube recirculation system. Also, compact, thin plastic seal is available. Nut outside diameter is compact compare with the return tube recirculation system.

2. Specifications

(1) Ball recirculation system

End-deflector recirculation system has features of high-speed, low-noise operation, and compact ball nut. The structure of recirculation parts are as follows.

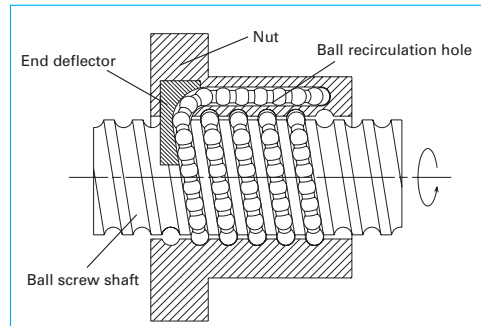

Fig. 1 Structure of End-deflector recirculation system

(2) Accuracy grade and axial play

The available standard accuracy grade and axial play are as follows. Please consult NSK for other grades.

Table 1 Accuracy grade and axial play

Accuracy grade	Ct7
Axial play	S, 0.020 mm or less; N, 0.050 mm or less

(3) Allowable d·n value and the criterion of maximum rotational speed

Allowable d·n value and the criterion of maximum rotational speed are shown below. Please consult NSK if the rotational speed exceeds the permissible range below.

Table 2 Allowable d·n value and the criterion of maximum rotational speed

Allowable d·n value	120 000 or less
Criterion of maximum rotational speed	2 400 min ⁻¹

d·n value: shaft dia. d [mm] × rotational speed n [min⁻¹]

Note: Please also review the critical speed. See "Technical Description: Permissible Rotational Speed" (page B47) for details.

(4) Ball retaining piece NSK S1™

The NSK S1, resin retainers between the balls, significantly extend ball screw durability to the moment load.

3. Design Precautions

The HTF-SRD type is designed to distribute the load uniformly to the load balls for high-load drive mechanism. We recommend installing the ball screws in the way shown below for the full use of this characteristic.

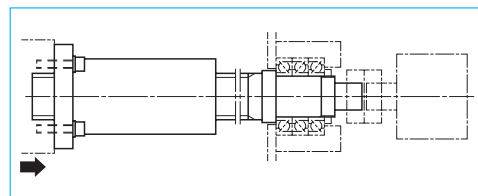

Fig. 2 Recommended installing direction of high-load drives ball screw

In addition, we will make full analysis when you use the HTF-SRD type under extreme conditions such as application of extremely high load or operating in short stroke. Contact NSK about operating conditions (see page B531). When designing the screw shaft end, one end

of the screw shaft must meet either one of the following conditions. If not, we cannot install the ball nut on the screw shaft.

- Cut the ball groove through to the shaft end.
- The diameters of bearing journals and the gear or pulley seat must be less than the root diameter of ball groove "dr" specified on the dimension table.

For general precautions regarding ball screws, refer to "Design Precautions" (page B83) and

"Handling Precautions" (page B103).

4. Product categories

The HTF-SRD type has a model as follows.

Table 3 HTF-SRD type product categories

Nut model	Shape	Flange shape	Preload system
HTF-SRD		Circular III	Non-preload Slight axial play

5. Structure of model number and reference number

The followings describe the structure of "Model number" and "Reference number for ball screw".

◇Model number



◇Reference number for ball screw

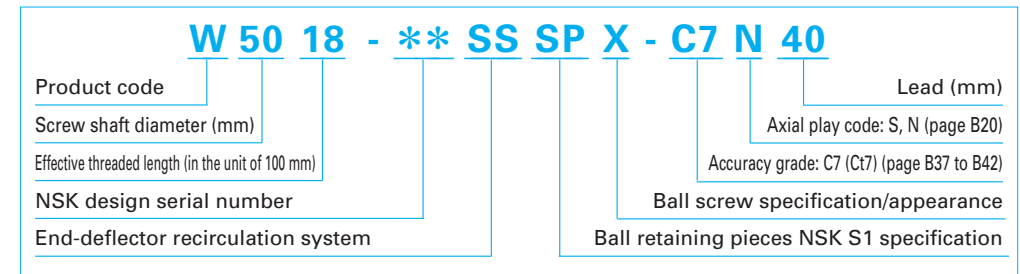

6. Handling Precautions

Maximum operating temperature: 70°C (at outside diameter of ball nut)
The lubricant deteriorates, operating temperature

is recommended 60°C and under. Please consult NSK in the case of a short stroke operation less than or equal to four times the length of the ball screw lead.

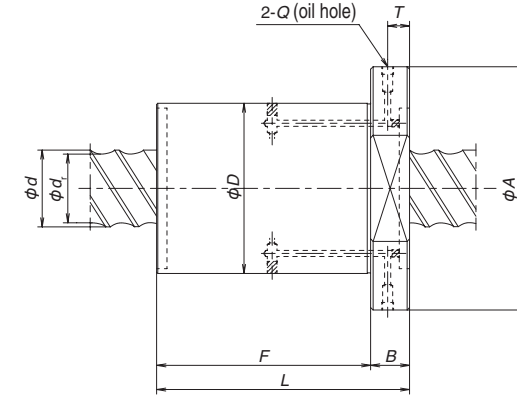
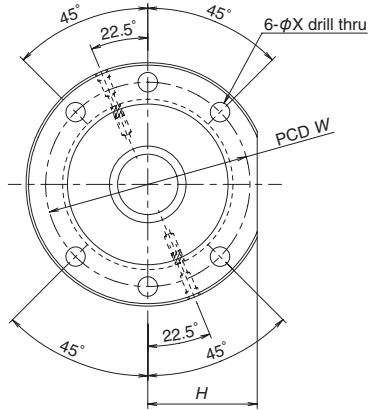

Model No.	Shaft dia. <i>d</i>	Lead <i>l</i>	Root dia. <i>d_r</i>	Effective turns of balls	Basic load rating (kN)		Allowable axial load (kN)
					Dynamic <i>C_d</i>	Static <i>C_{0b}</i>	
HTF-SRD5040-6E	50	40	39	6	243	491	67.6
HTF-SRD5040-8E				8	319	679	92
HTF-SRD6332-4E	63	32	49	4	292	590	72.6
HTF-SRD6340-6E		40		6	363	768	106
HTF-SRD6340-8E	8		476	1 060	144		
HTF-SRD8050-6E	80	50	63	6	502	1 180	163
HTF-SRD8050-8E				8	658	1 630	224
HTF-SRD10060-6E	100	60	83	6	583	1 490	211
HTF-SRD10060-8E				8	765	2 060	288
HTF-SRD12070-6E	120	70	103	6	630	1 810	259
HTF-SRD12070-8E				8	826	2 520	352

Notes: 1. The right hand screw is the standard. For specifications on left hand screws, contact NSK.
 2. Please consult NSK if load exceeds the allowable axial load.
 3. The allowable axial load is determined in accordance with the mounting conditions of ball screws recommended by NSK (See page B517). If your mounting conditions differ from those provided, please consult NSK.

Ball nut dimensions									Max. feeding speed (mm/sec)
Nut entire length <i>L</i>	Nut dia. <i>D</i>	Flange dia. <i>A</i>	Notch size <i>H</i>	Flange width <i>B</i>	Nut length <i>F</i>	Bolt hole PCD <i>W</i>	Bolt hole size <i>X</i>	Oil hole position <i>T</i>	
159	115	165	72.5	28	131	140	14	16	1 600
199					171				
176	140	190	85	32	144	165	14	18	1 000
163		200	90		131	170	18		1 250
203	175	250	110	40	171	210	22	18	1 250
194					154				
244	195	270	122	40	204	235	22	20	1 200
225					185				
285	210	285	130	50	245	250	22	25	1 160
260					210				
330					280				

Unit: mm

HTF-SRD

B-3-3.5.3 HTF Type for High-Load Drives

This product is being applied for a patent.

1. Features

- High load carrying capacity
Has an ideal design to bear heavy load. It significantly enhances load rating as well as maximum permissible load.

- Respond to various shaft end configuration
Additional ball screw shaft machining is not required. HTF type responds to various shaft ends that convey high torque.

HTF type can be used with: involute spline (JIS B 1603), straight sided spline (JIS B 1601), key seat, etc.

2. Specifications

(1) Ball recirculation system

Structure of recirculation system is shown in Fig. 1.

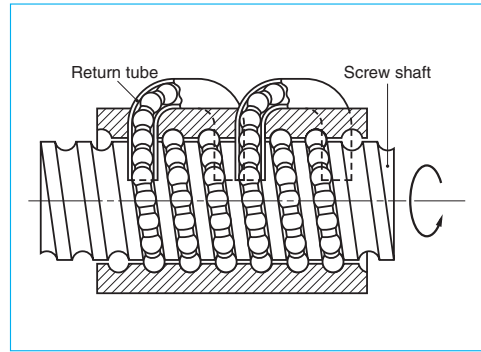

Fig. 1 Structure of return tube recirculation system

(2) Accuracy grade and axial play

The allowable standard accuracy grade and axial play are as follows. Please consult NSK for other grades.

Table 1 Accuracy grade and axial play

Accuracy grade	Ct7
Axial play	S, 0.020 mm or under; N, 0.050 mm or under

(3) Allowable d·n value and the criterion of maximum rotational speed

Allowable d·n value and the criterion of maximum rotational speed are shown below. Please consult NSK if the rotational speed exceeds the permissible range below. For higher-speed operation, HTF-SRC type is recommend (See page B513).

Table 2 Allowable d·n value and the criterion of maximum rotational speed

Lead		- 20 mm	25 mm	30 - 32 mm
Allowable d·n value	Standard specification	70 000 or less	70 000 or less	50 000 or less
	High-speed specification	10 000 or less	-	-
Criterion of maximum rotational speed		3 125 min ⁻¹		

d·n value: shaft dia. d [mm] × rotational speed n [min⁻¹]

Note: Please also review the critical speed. See "Technical Description: Permissible Rotational Speed" (page B47) for details.

(4) Ball retaining piece NSK S1™

The NSK S1, resin retainers between the balls, significantly extend ball screw durability to the moment load.

(5) Other

Please consult NSK for special requests, such as the addition of a recirculation circuit to increase the load capacity, or the arrangement of all recirculation circuits on the same phase of ball nut circumference.

3. Design precautions

For designing shaft end configuration, you should take into account that the HTF type ball screws are dedicated to high-load drives.

The HTF type is designed to distribute the load uniformly to the load balls for high load drive mechanism.

We recommend installing the ball screws in the way shown in Fig. 2 for the full use of this characteristic. In addition, we will make full analysis when you use the HTF type under extreme conditions such as application of extremely high load or operating in short stroke. Contact NSK about operating conditions (See page B531).

When designing the screw shaft end, the one end shall be cut-through and shaft end dimension must be less than the root diameter

of ball groove. If not, the nut cannot be assembled.

For general precautions regarding ball screws, refer to "Design Precautions" (page B83) and "Handling Precautions" (page B103).

4. Product categories

The HTF type has a model as follows.

Table 3 HTF type product categories

Nut model	Shape	Flange shape	Preload system
HTF		Flanged Circular I	Non-preloaded Slight axial play

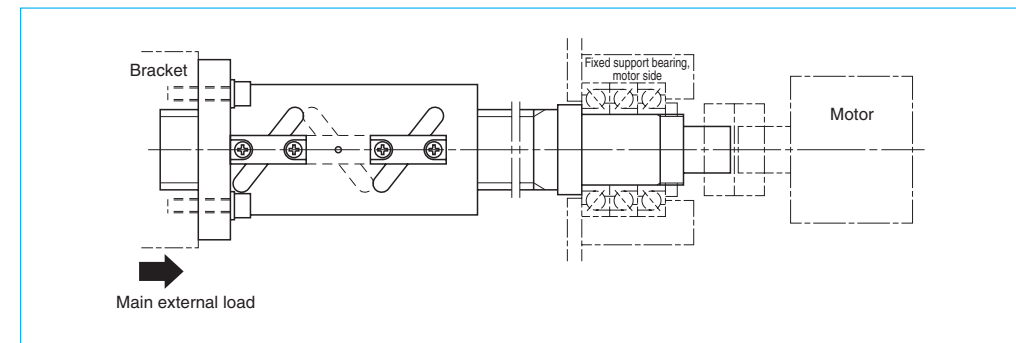
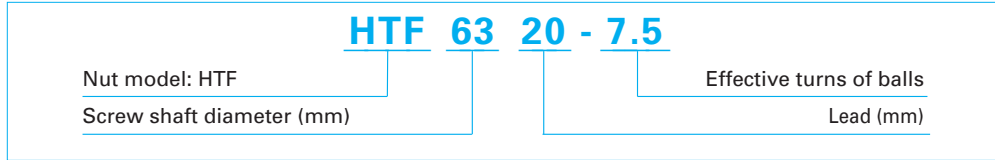

Fig. 2 Recommended installing direction of ball screws for high-load drives

5. Structure of model number and reference number

A structure of "Model number" and "Reference number for ball screw" are as follows.

◇Model number



◇Reference number for ball screw

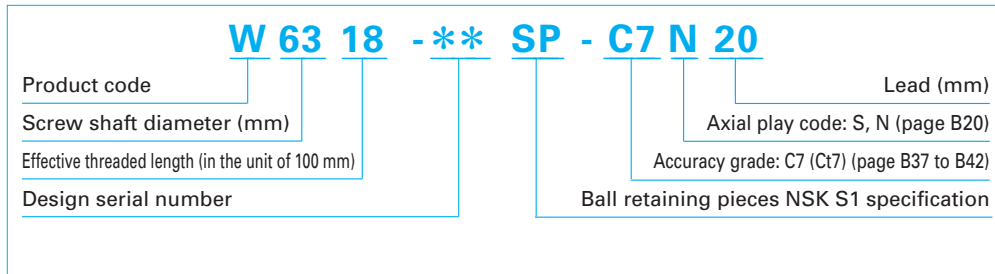

6. Handling precautions

Maximum operating temperature : 70°C
(at outside diameter of all nut)

The lubricant deteriorates, operating temperature is recommended 60°C and under.

Please consult NSK in the case of a short stroke

operation less than or equal to four times the length of the ball screw lead.

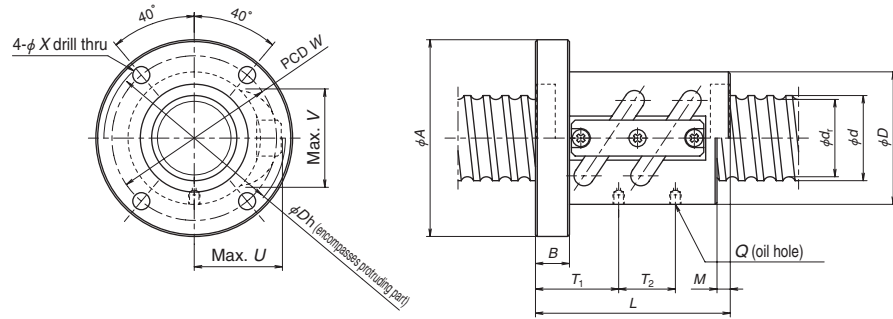

Nut model I

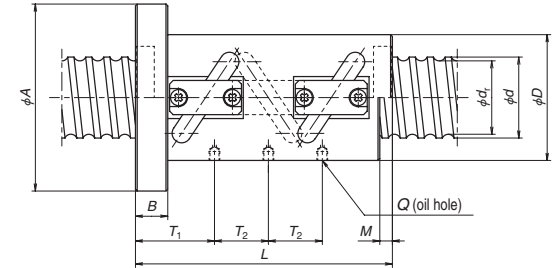
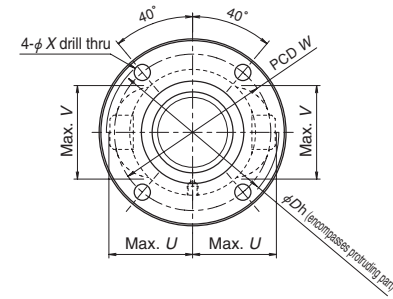

Nut model II

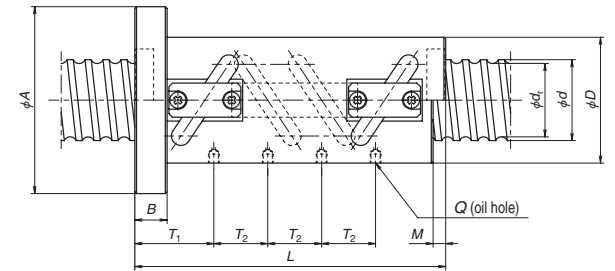
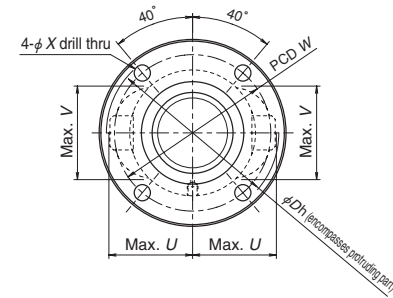

Nut model III

Unit: mm

Model No.	Shaft dia. <i>d</i>	Lead <i>l</i>	Root dia. <i>d_r</i>	Effective turns of balls Turns × Circuits	Nut model	Basic load rating (kN)		Allowable axial load (kN)
						Dynamic <i>C_a</i>	Static <i>C_{0a}</i>	
HTF3210-5	32	10	25.6	2.5×2	I	88.7	169	20.3
HTF3610-5	36	10	29.6	2.5×2	I	96.1	191	23.4
HTF3612-5		12	29			112	228	28.3
HTF4010-7.5	40	10	33.6	2.5×3	II	149	344	39.6
HTF4012-7.5		12	33	2.5×3		184	422	48.0
HTF4510-7.5	45	10	38.6	2.5×3	II	158	386	45.3
HTF4510-10				2.5×4	III	203	514	60.4
HTF4512-7.5				2.5×3	II	195	473	55.0

See HTF-SRC type (page B513) regarding shaft diameter 50 - 120 mm. Consult NSK for shaft diameter and lead except HTF-SRC type.

HTF14020-7.5	140	20	126	2.5×3	II	829	3 000	361
HTF14020-10				2.5×4	III	1 060	4 000	481
HTF14025-7.5				25	124	2.5×3	II	1 050
HTF14025-10	2.5×4	III	1 350			4 810	564	
HTF14025-10.5	3.5×3	I	1 380			4 910	595	
HTF14025-14	3.5×4	III	1 770			6 540	793	

Notes: 1. The right hand screw is the standard. "L" is added to the end of the model code for the left turn screw.
2. If there is no seal, the nut length is shorter by the lengths of "M" than those with a seal.

Ball nut dimensions													Oil hole	Oil hole positions		Max. feeding speed (mm/sec)
Nut length <i>L</i>	Nut dia. <i>D</i>	Flange dia. <i>A</i>	Flange width <i>B</i>	Seal width <i>M</i>	Bolt hole PCD <i>W</i>	Bolt hole size <i>X</i>	Protruding tube dimensions			<i>Q</i>	<i>T₁</i>	<i>T₂</i>				
103	58	92	18	7	75	9	40.5	42	82	M6×1	36.5	30	520			
103	62	96	18	7	79	9	43	45	87		36.5	30	460			
123	66	100	22	8	83		9	46.5	46	94	M6×1	44	36	550		
143	66	100	18	7	83	9	45	48	91	M6×1		46.5	30	410		
171	70	104	22	8	87	9	47.5	50	96	M6×1	56	36	500			
143	70	104	18	7	87	9	47	52	95		M6×1	46.5	30	370		
173										56					36	440
171																

281	204	250	40	12	226	14	122.5	148	248	Rc1/8	96	60	230
341													
338	204	250	40	17	226	14	127.5	153	258	Rc1/8	109.25	75	200
413													
413													
513													

3. Please consult NSK if load exceeds the allowable axial load.
4. The allowable axial load is determined in accordance with the mounting conditions of ball screws recommended by NSK (see page B522). If your mounting conditions differ from those provided, please consult NSK.

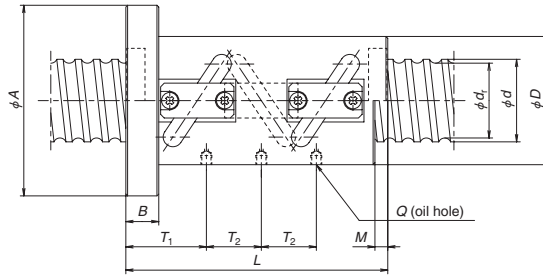
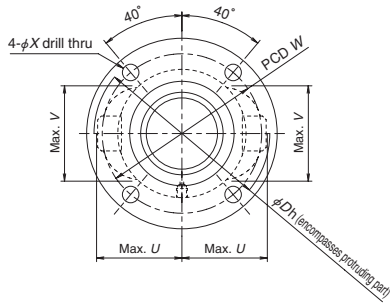

Nut model II

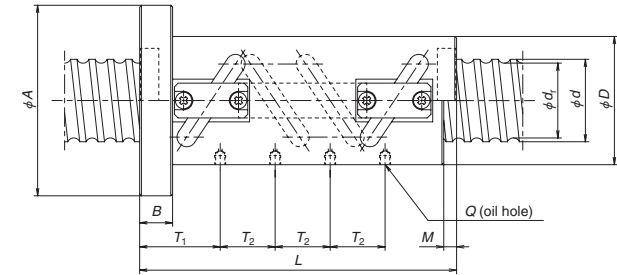

Nut model III

Model No.	Shaft dia. <i>d</i>	Lead <i>l</i>	Root dia. <i>d_r</i>	Effective turns of balls $\frac{L}{X}$ Circuits	Nut model	Basic load rating (kN)		Allowable axial load (kN)
						Dynamic <i>C_d</i>	Static <i>C_{0s}</i>	
HTF14030-7.5	140	30	121	2.5×3	II	1 310	4 110	487
HTF14030-10				III	1 670	5 490	649	
HTF14030-10.5				II	1 710	5 710	678	
HTF14032-7.5		32	118	2.5×3	II	1 590	4 740	549
HTF14032-10				III	2 040	6 320	732	
HTF14032-10.5				II	2 080	6 420	757	
HTF16025-7.5	160	25	144	2.5×3	II	1 140	4 140	495
HTF16025-10				III	1 450	5 520	660	
HTF16030-7.5				30	141	2.5×3	II	1 400
HTF16030-10		III	1 790			6 340	752	
HTF16030-10.5		II	1 830			6 520	788	
HTF16032-7.5		32	138	2.5×3	II	1 660	5 370	636
HTF16032-10	III			2 130	7 160	848		
HTF16032-10.5	II			2 180	7 460	885		
HTF20030-7.5	200	30	181	2.5×3	II	1 550	5 960	718
HTF20030-10				III	1 980	7 950	958	
HTF20032-7.5				32	178	2.5×3	II	1 840
HTF20032-10		III	2 360			9 120	1 080	

Notes: 1. The right hand screw is the standard. "L" is added to the end of the model code for the left turn screw.
2. If there is no seal, the nut length is shorter by the lengths of "M" than those with a seal.

Ball nut dimensions													Max. feeding speed (mm/sec)
Nut length <i>L</i>	Nut dia. <i>D</i>	Flange dia. <i>A</i>	Flange width <i>B</i>	Seal width <i>M</i>	Bolt hole PCD <i>W</i>	Bolt hole size <i>X</i>	Protruding tube dimensions			Oil hole <i>Q</i>	Oil hole positions		
411	222	282	50	22	252	18	139	160	281	Rc1/8	134.5	90	170
501												120	
501												120	
465		296	70	22	259	22	148	163	299		166.5	96	190
561												96	
561												128	
338	234	280	40	17	256	14	138	173	279	Rc1/8	109.25	75	180
413												75	
411												90	
501		294	50	22	264	18	148	177	299		134.5	90	150
501												120	
465												96	
561	308	70	22	271	22	152	181	307	166.5	96	160		
561										128			
411										290		350	50
501	90												
465	96												
561	364	70	22	327	22	182	215	367	166.5		96	130	
561											120		
561											130		

3. Please consult NSK if load exceeds the allowable axial load.
4. The allowable axial load is determined in accordance with the mounting conditions of ball screws recommended by NSK (see page B522). If your mounting conditions differ from those provided, please consult NSK.

NSK Technical Data Sheet for NSK High-Load Drive Ball Screws

Made-to-order ball screw

Company name:	Date:	NSK sales office
Section:	Person in charge:	
Address:		

Name of machine*1 : Electric injection molding machine; 30-ton capacity Application*2 : Clamping axis

Drawing/rough sketch attached?: Yes No

*1 Please specify capacity of the machine in case of injection molding machine or press.
*2 Please indicate the axis. (Examples: injection axis and clamping axis)

1. Use conditions

Operating conditions	<input checked="" type="checkbox"/> Shaft rotation — Moving nut	<input checked="" type="checkbox"/> Normal operation	Degree of vibration/impact	<input type="checkbox"/> Smooth operation without impact
	<input type="checkbox"/> Shaft rotation — Moving shaft	<input type="checkbox"/> Back drive operation		<input checked="" type="checkbox"/> Normal operation
Direction of load*3	<input type="checkbox"/> C-C <input checked="" type="checkbox"/> T-T <input type="checkbox"/> T-C <input type="checkbox"/> C-T <input type="checkbox"/> Other	Mounting orientation	<input checked="" type="checkbox"/> Horizontal	
	(Refer to figures below.)		<input type="checkbox"/> Vertical (Indicate the direction of gravity.)	
Lubricant	<input checked="" type="checkbox"/> Grease (Brand name: <i>High-load grease with an extreme pressure additive</i>) <input type="checkbox"/> Oil (Maker: _____)	How to replenish lubricant	<input checked="" type="checkbox"/> Grease gun <input type="checkbox"/> Automatic lubricant	
Request for oil hole	<input checked="" type="checkbox"/> NSK recommended <input type="checkbox"/> Your request		(_____ cm ³ / _____ cycles)	
Necessity of seals	<input checked="" type="checkbox"/> Yes <input type="checkbox"/> No	NSK S1 necessary?	<input checked="" type="checkbox"/> NSK recommended <input type="checkbox"/> Not necessary	
Environment	Temperature (<u>40</u> deg)	Particles / <input type="checkbox"/> Yes (Size of particle : a) -0.1, b) over 0.1-0.3, c) over 0.3- , d) Ingredient: _____) <input checked="" type="checkbox"/> No particle.		
Surface treatment	<input checked="" type="checkbox"/> Not required <input type="checkbox"/> Low-temperature chrome plating <input type="checkbox"/> Fluoride low-temperature chrome plating <input type="checkbox"/> Other			
Quantity in mass-production	/Month	/Year	/Lot	Quantity used per machine: <u>1</u> pcs./machine

*3 Please specify loading direction code on the figures below. (Shaft fixed: ■, Main load: ←)

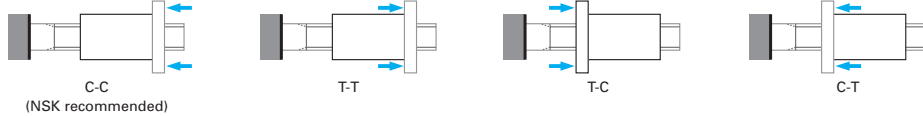

2. Specifications

Shaft diameter	$\phi 140$ mm	Lead	<u>32</u> mm	Accuracy grade	<u>C17</u>	Axial play	<u>0.050 or less</u> mm max.
Nut model No.	<u>HTF 14032-7.5-S1</u>	Effective turns of balls	<u>2.5 x 3</u>	Direction of turn	<u>right</u>	Thread length / Overall shaft length	<u>1000 / 1500</u>

Special note / Requests

See nut stroke on the drawing

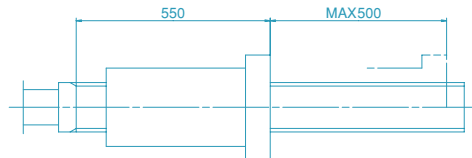

NSK Technical Data Sheet for NSK High-Load Drive Ball Screws

3. Load chart

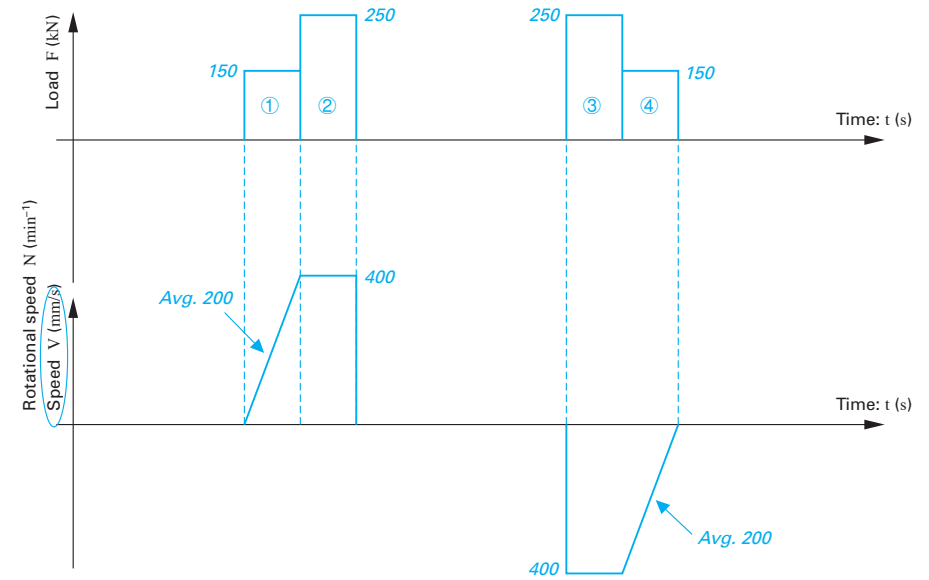

	Axial load* F (kN)	Rotational speed or Average speed N (min ⁻¹) V (mm/s)	Time t (s)	Stroke St (mm)	Remarks
1	150	200	0.5	100	
2	250	400	0.5	200	
3	250	400	0.5	200	
4	150	200	0.5	100	
5			Total: 2.0	Total: 600	
6					
7					
8					
9					
10					

Dynamic axial load (Max.)*: 250 (kN) Static axial load (Max.)*(at 0 mm/s): _____ (kN)
Stroke in normal use: 300 (mm) Maximum stroke: 500 (mm)
Cycle time: 2.0 (s) Required life: 2500h

*If you use multiple ball screws in an axis, fill out the axial load per ball screw.

4. Plan to conduct the endurance test of the ball screw?

Actual data on the machine Yes N/A

Planning to check endurance (Date: *From the middle of December 2013*)

No (Reason: _____)

Endurance of the ball screw

- (1) Mounting accuracy, load conditions, and lubricating conditions are the main factors affecting the ball screw fatigue life. Therefore, we recommend evaluating the influence of those factors on actual use of your machines.
- (2) A temperature rise caused by operational and environmental conditions may reduce the effectiveness of lubricant.

NSK Technical Data Sheet for NSK High-Load Drive Ball Screws

Made-to-order ball screw

Company name:	Date:	NSK sales office
Section:	Person in charge:	
Address:		

Name of machine*1 : _____ Application*2 : _____

Drawing/rough sketch attached?: Yes No

*1 Please specify capacity of the machine in case of injection molding machine or press.
*2 Please indicate the axis. (Examples: injection axis and clamping axis)

1. Use conditions

Operating conditions	<input type="checkbox"/> Shaft rotation — Moving nut	<input type="checkbox"/> Normal operation	Degree of vibration/impact	<input type="checkbox"/> Smooth operation without impact
	<input type="checkbox"/> Shaft rotation — Moving shaft	<input type="checkbox"/> Back drive operation		<input type="checkbox"/> Normal operation
Direction of load*3	<input type="checkbox"/> C-C <input type="checkbox"/> T-T <input type="checkbox"/> T-C <input type="checkbox"/> C-T <input type="checkbox"/> Other	(Refer to figures below.)		Mounting orientation
	Lubricant		How to replenish lubricant	<input type="checkbox"/> Horizontal
Request for oil hole		<input type="checkbox"/> Grease gun <input type="checkbox"/> Automatic lubricant		<input type="checkbox"/> Vertical (Indicate the direction of gravity.)
Necessity of seals	<input type="checkbox"/> Yes <input type="checkbox"/> No	NSK S1 necessary?	(_____ cm ³ / _____ cycles)	
	Environment		<input type="checkbox"/> Grease <input type="checkbox"/> Oil (Brand name: _____ Maker: _____)	
Surface treatment	Temperature (_____ deg)		Particles / <input type="checkbox"/> Yes (Size of particle : a) -0.1, b) over 0.1-0.3, c) over 0.3- _____, d) Ingredient: _____) <input type="checkbox"/> No particle.	
	Quantity in mass-production		Quantity used per machine	
/Month		/Year	/Lot	pcs./machine

*3 Please specify loading direction code on the figures below. (Shaft fixed: ■, Main load: ←)

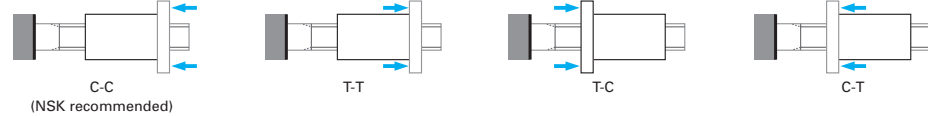

2. Specifications

Shaft diameter	φ mm	Lead	mm	Accuracy grade		Axial play	mm max.
Nut model No.		Effective turns of balls		Direction of turn		Thread length / Overall shaft length	/

Special note / Requests

NSK Technical Data Sheet for NSK High-Load Drive Ball Screws

3. Load chart

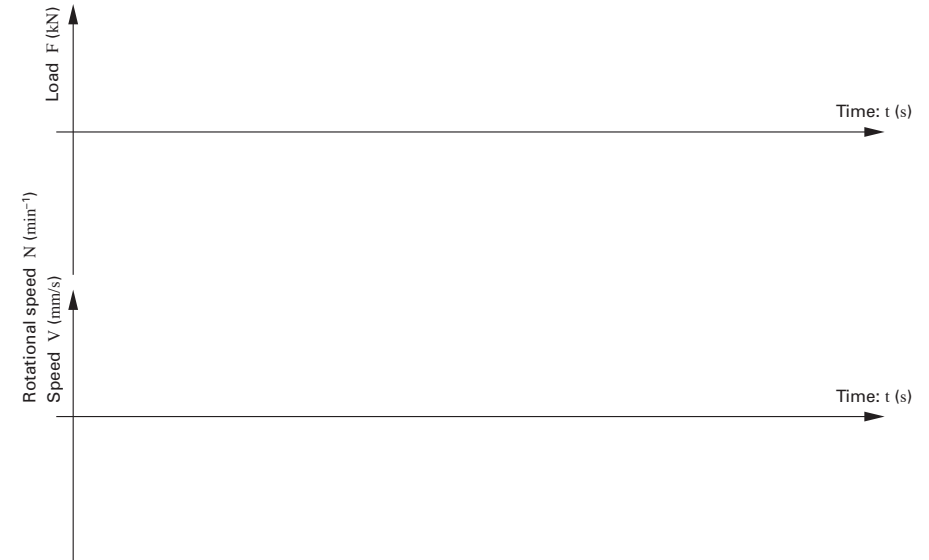

	Axial load* F (kN)	Rotational speed or Average speed N (min ⁻¹)	V (mm/s)	Time t (s)	Stroke St (mm)	Remarks
1						
2						
3						
4						
5						
6						
7						
8						
9						
10						

Dynamic axial load (Max.)*: (kN) Static axial load (Max.)*(at 0 mm/s): (kN)
 Stroke in normal use: (mm) Maximum stroke: (mm)
 Cycle time: (s) Required life:

*If you use multiple ball screws in an axis, fill out the axial load per ball screw.

4. Plan to conduct the endurance test of the ball screw?

Actual data on the machine → Yes
 → N/A → Planning to check endurance (Date: _____)
 → No (Reason: _____)

Endurance of the ball screw

- (1) Mounting accuracy, load conditions, and lubricating conditions are the main factors affecting the ball screw fatigue life. Therefore, we recommend evaluating the influence of those factors on actual use of your machines.
- (2) A temperature rise caused by operational and environmental conditions may reduce the effectiveness of lubricant.

B-3-3.6.1 VSS Type for Contaminated Environments

1. Features

● **High dust-resistance**
Specially profiled screw shaft grooves and high performance seals prevent the entry of fine contaminants. Reduces particle penetration rate to less than 1/15 of existing standard products.

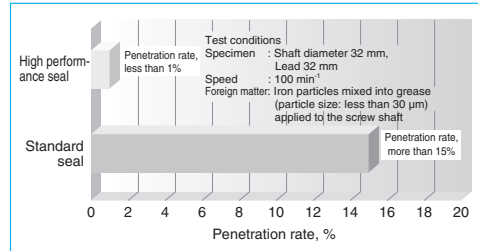

Fig. 1 Particle penetration rate

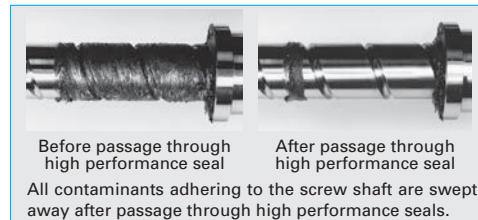

Fig. 2 Contamination before and after particle penetration test

● **Long life**
High performance seals extend ball screw durability under severely contaminated environments with iron powder. Extreme durability tests under contaminated environments show the durability of the VSS type extends more than four times longer than our existing type with a standard seal.

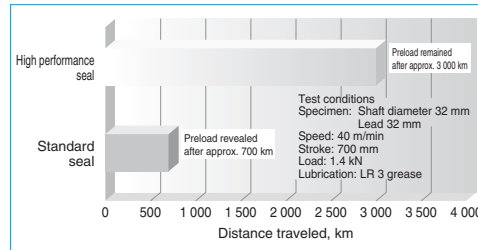

Fig. 3 Extreme durability test results using iron particles

● **High speed**
For ultimate smoothness of ball recirculation, the internal ball recirculation system enables high-speed operation at a maximum of d·n

150 000. Large lead specifications allow high-speeds of 150 m/min.

● **Low-noise**
Reduces noise level by more than 6 dB compared with our conventional tube-type ball screws, thereby providing low-noise and good noise tone features.

● **Compact size**
Ball nut external diameter is up to 25% smaller than our conventional models.

2. Specifications

(1) Ball recirculation system
End-deflector recirculation system has features of high-speed operation with low-noise, and compact ball nut. The structure of recirculation system is shown in **Fig. 4**.

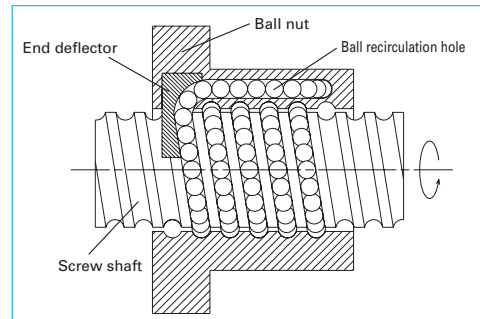

Fig. 4 Structure of end deflector recirculation system

(2) Accuracy grade and axial play
The available standard accuracy grade and axial play are as follows. Please consult NSK for other grades.

Accuracy grade	C5
Axial play	Z, 0 mm (preloaded) T, 0.005 mm or less; S, 0.020 mm or less

(3) Allowable d·n value and the criterion of maximum rotational speed

Allowable d·n value and the criterion of maximum rotational speed are shown below. Please consult NSK if the rotational speed exceeds the permissible range below.
Allowable d·n value: 150 000 or less
Criterion of maximum rotational speed: 3 000 min⁻¹
Note: Please also review critical speed. See

"Technical Description: Permissible Rotational Speed" (page B47) for details.

(4) High performance seal
High performance seal (Japanese patents: 3646452, 3692203) with special lip that contacts screw shaft cross-section and prevents entry of fine contaminants.

(5) Lubrication unit
Incorporates NSK K1 lubrication unit to sufficiently lubricate the high performance seal lip, reduce friction, and improve durability.

(6) optional
Non-contact metal protector that traces the ball screw grooves and safeguards the seal against high-temperature foreign matter.

3. Design precaution

When designing the screw shaft end, one end of

the screw must meet either one of the following conditions. If not, we cannot install the ball nut on the screw shaft.

- Cut the ball groove through to the shaft end.
- The diameters of bearing journals and the gear or pulley seat must be less than the root diameter of ball groove "dr" specified on the dimension table.

High performance seals may increase torque, which may in turn increase temperature. Please inform NSK about your service conditions using the technical data sheet on page B542.

For general precautions regarding ball screws, refer to "Design Precautions" (page B83) and "Handling Precautions" (page B103).

4. Structure of model number and reference number

The followings describe the structure of "Model number" and "Reference number for ball screw".

◇ Model number

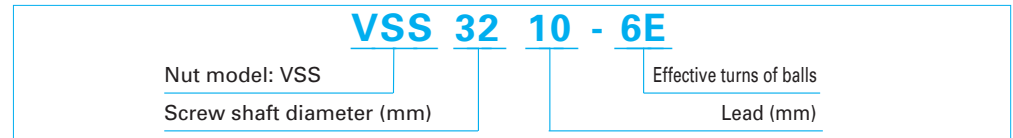

◇ Reference number for ball screw

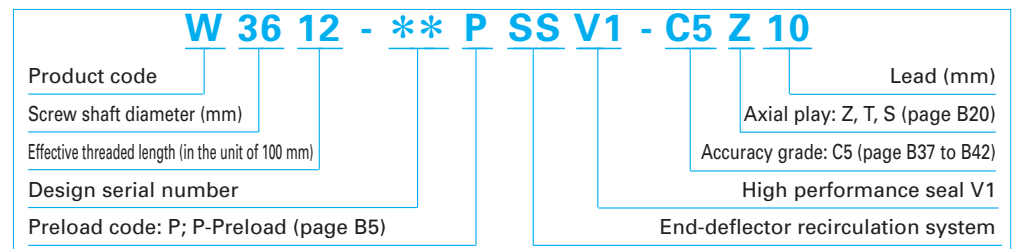

5. Handling Precautions

Maximum operating temperature: 50°C
Maximum momentary operating temperature: 80°C
Chemical precautions: Never expose the ball screw to grease-removing organic solvents such as hexane or thinner. Never immerse the ball screw in kerosene or rust preventive oils which contain kerosene.

The data shown in the catalog are the results of our tests, and no warranty is given to sealing performance on actual usage on machinery. Sealing performance is affected by usage environment and lubrication conditions. Dust covers and other measures to keep machinery free of dust are recommended.

View X-X

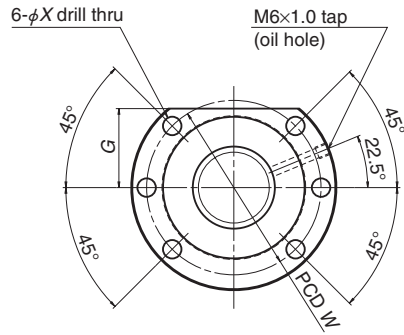

Screw shaft diameter $d = 32$ mm

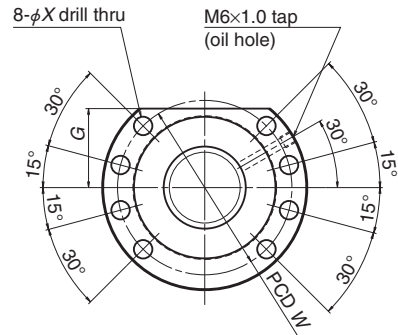

Screw shaft diameter $d \geq 40$ mm

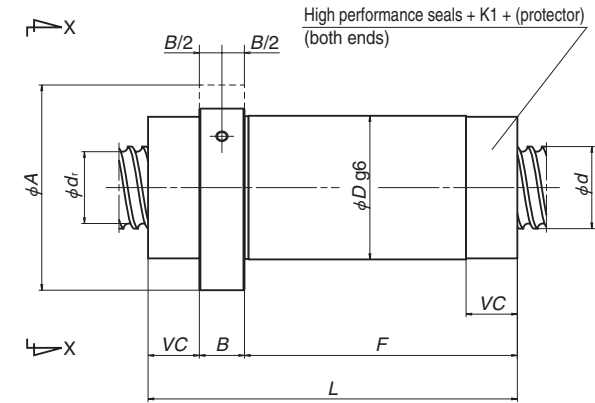

Model No.	Shaft dia. d	Lead l	Root dia. d_r	Effective turns of balls	Basic load rating (N)		Axial rigidity K (N/ μ m)
					Dynamic C_d	Static C_{0a}	
VSS3210-6E	32	10	27.2	6	43 300	111 000	682
VSS3216-5E		16		5	36 700	90 800	563
VSS3220-5E		20		5	36 700	90 800	561
VSS3232-4E		32		4	25 000	58 300	387
VSS4040-4E	40	40	34.4	4	33 600	83 900	472
VSS5050-4E	50	50	44.4	4	37 300	105 000	559

Notes: 1. The right hand screw is the standard. For specifications on left hand screws, contact NSK.

2. Rigidity in the table is theoretical value obtained from the elastic deformation between screw groove and ball when the preload is 1.5% of the basic dynamic load rating, and axial load is applied to it. Refer to "Technical Description" (page B37) if axial load and preload differs from the conditions above, or when considering change in the deformation of the ball nut itself.

3. Products with axial play may have a partially negative play (preloaded condition) depending on screw length. Refer to "Manufacturing range of effective screw length in combination of accuracy grade and axial play" (page B20).

Unit: mm

Nut entire length L	Ball nut dimensions								Maximum shaft length
	Nut outside diameter D	Flange outside diameter A	Flange width B	Nut length F	Notch size G	Seal installation dimensions VC	Bolt hole PCD W	Bolt hole dimensions X	
132	56	86	18	89.5	34	24.5	71	9	2 800
150				107.5					
169				126.5					
122				79.5					
144	70	100	22	94	38.5	27.5	85	9	3 800
164	82	118	22	114.5	46	27.5	100	11	5 000

B-3-3.6.2 Ball Screw with X1 Seals for Contaminated Environments and Grease Retention

1. Features

● Highly dustproof

Particle penetration ratio reduced to less than 1/30 of existing standard seals, thus contributing to longer service life for machine tools.

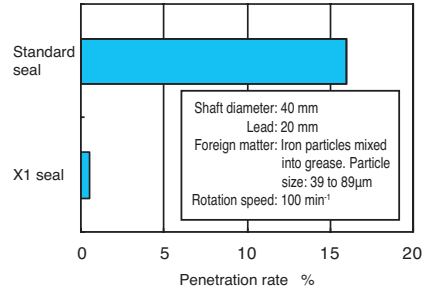

Fig. 1 Results of particle penetration rate test

● Superior grease retention

Automatically adding grease makes it possible to reduce the amount used and keep it from spattering.

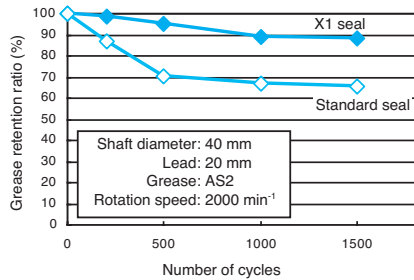

Fig. 2 Results of grease leakage test

● Contact seal with low torque

Optimizing the seal shape reduces torque and enhances seal performance.

2. Specifications

(1) Structure

The ball screw with X1 seals has a double seal structure combining a dustproof seal and a grease-retaining seal.

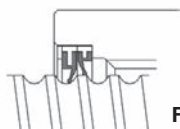

Fig. 3 Seal structure

(2) Scope of application in NSK Ball Screw series
This series is standard for the following two types.

Ball screws for high-speed machine tools	HMS type	Nut model: ZFRC
	HMD type	Nut model: EM
	BSS type	Nut model: BSS

For specifications other than the above, please consult NSK. Table 1 shows the minimum nut outer diameter on which X1 seals can be mounted.

Table 1 The minimum nut outer diameter on which X1 seals can be mounted

Shaft diameter: 32 mm	56 mm
Shaft diameter: 40 mm	70 mm
Shaft diameter: 45 mm	75 mm
Shaft diameter: 50 mm	82 mm

(3) Accuracy grade / axial play

Table 2 shows standard tolerance classes and axial clearances. Please consult NSK for tolerance classes other than those in the table.

Table 2 Accuracy grade and axial play

Accuracy grade	C3, C5
Axial play	0 mm (preloaded)

(4) Design-related precautions

When designing the screw shaft end, assume that the end of the screw shaft is cut.

The temperature will increase somewhat when torque is applied if an X1 seal is attached. Please inform NSK about your service conditions using the technical data sheet on page B542.

Maximum overall shaft length is 2900 mm.

For general precautions regarding ball screws, refer to "Design Precautions" (page B83) and "Handling Precautions" (page B103).



HMS type

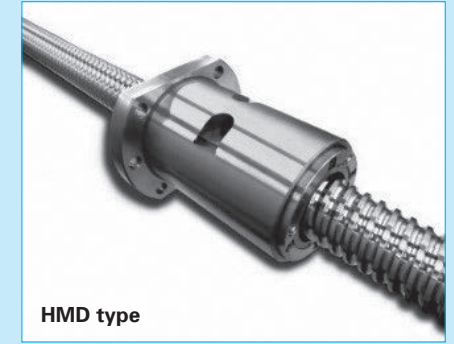

HMD type



BSS type

Fig. 4 External appearance

3. Example of reference number

A structure of "Reference number for ball screw" is as follows.

Note: "X1" is added at the end of "nut model code" and "Specifications number".

◇Reference number for ball screw

W4010--ZMX1-C5Z16**

X1 seal equipped type ball screw code

4. Precautions for use

Temperature range for use: Maximum temperature: 60°C (at outside diameter of ball nut)

Chemicals that should not come to contact: Do not leave ball screw in organic solvent, white kerosene such as hexane, thinner which removes oil, and rust preventive oil which contains white kerosene.

The data shown in the catalog are the results of our tests, and no warranty is given to sealing performance on actual usage on machinery. Sealing performance is affected by usage environment and lubrication conditions. Dust covers and other measures to keep machinery free of dust are recommended.

Ball Screw with X1 Seals for Contaminated Environments and Grease Retention

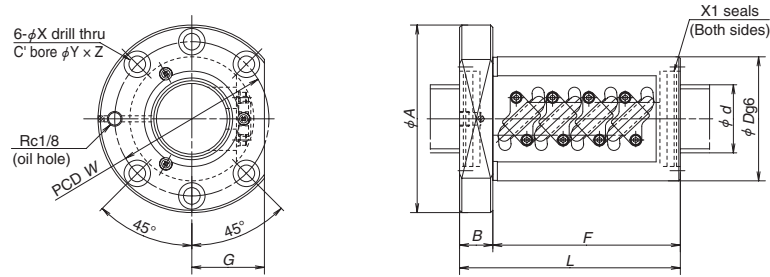

HMS type (Nut model : ZFRC)

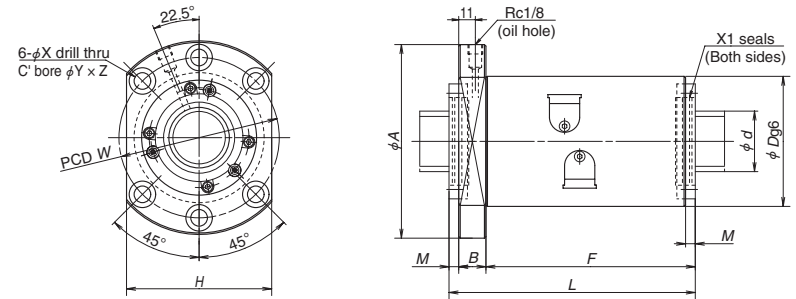

HMD type (Nut model : EM)

Applicable dimensions for HMS type

Unit: mm

Model No.	Shaft dia. <i>d</i>	Lead <i>l</i>	Basic load rating (N)		Nut dimensions									
			Dynamic C_a	Static C_{0a}	<i>L</i>	<i>F</i>	<i>B</i>	<i>D</i>	<i>A</i>	<i>G</i>	Bolt holes			
											<i>X</i>	<i>Y</i>	<i>Z</i>	<i>W</i>
ZFRC3205-10	32	5	18 500	56 100	107	87	20	58	85	32	6.6	11	6.5	71
ZFRC4010-10	40	10	52 000	137 000	173	151	22	82	124	47	11	17.5	11	102
ZFRC4012-10		12	61 000	155 000	197	175		86	128	48				
ZFRC4508-10	45	8	37 300	118 000	146	124	22	82	124	47	11	17.5	11	102
ZFRC5010-10	50	10	57 700	175 000	174	151	23	93	135	51	11	17.5	11	113
ZFRC5012-10		12	77 600	214 000	200	177		100	146	55				

Note: 1.The right hand screw is the standard. For specifications on left hand screws, contact NSK.

Applicable dimensions for HMD type

Unit: mm

Model No.	Shaft dia. <i>d</i>	Lead <i>l</i>	Basic load rating (N)		Nut dimensions										
			Dynamic C_a	Static C_{0a}	<i>L</i>	<i>F</i>	<i>M</i>	<i>B</i>	<i>D</i>	<i>A</i>	<i>H</i>	Bolt holes			
												<i>X</i>	<i>Y</i>	<i>Z</i>	<i>W</i>
EM4016-4E	40	16	57 100	130 000	172	148	6	18	86	128	96	11	17.5	11	106
EM4020-6E		20	66 900	165 000	164	139	7								
EM4516-4E	45	16	59 600	145 000	173	148.5	6.5	18	92	134	102	11	17.5	11	112
EM4520-6E		20	69 100	186 000	164	139	7								
EM5016-4E	50	16	61 800	160 000	173	148.5	6.5	18	98	140	107	11	17.5	11	118
EM5020-6E		20	73 200	206 000	164	139	7								

Note: 1.The right hand screw is the standard. For specifications on left hand screws, contact NSK.

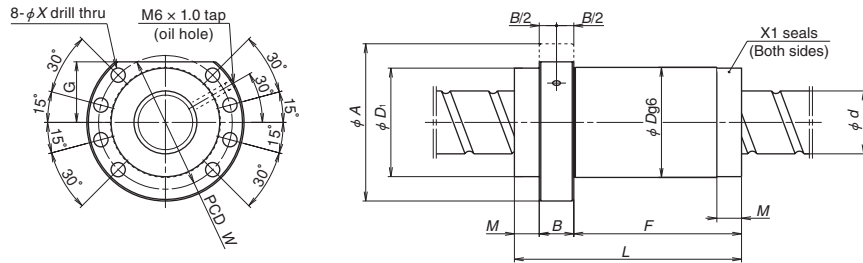

End deflector type (Nut model : BSS)

Applicable dimensions for End deflector type

Unit: mm

Model No.	Shaft dia. <i>d</i>	Lead <i>l</i>	Basic load rating (N)		Nut dimensions									
			Dynamic C_a	Static C_{0a}	<i>L</i>	<i>F</i>	<i>M</i>	<i>B</i>	<i>D</i>	D_1	<i>A</i>	<i>G</i>	Bolt holes	
													<i>X</i>	<i>W</i>
BSS3205-4E	32	5	14 200	41 400	77	46	19	12	56	55	86	34	9	71
BSS3210-6E		10	43 300	111 000	114	80.5	15.5	18		55.5				
BSS4010-5E	40	10	49 300	130 000	112	73	17	22	70	69	100	38.5	9	85
BSS4020-5E		20	49 300	130 000	159	120	17		82	81	118	46		
BSS5010-4E	50	10	44 600	129 000	159	120	17	22	82	81	118	46	11	100

NSK Data Sheet for Ball Screws in Contaminated Environments
 [Example] (Please copy) 1/1

Model: Washing machine Location: Workpiece transfer axis

1. Operating Conditions

Operating Conditions	a) Shaft rotation – nut moving b) Shaft rotation – shaft moving c) Nut rotation – nut moving d) Nut rotation – shaft moving	Stroke in Normal Use	400 [mm] (Please indicate operating pattern)
		Mounting Orientation	a) Vertical b) Horizontal
Lubricant	a) Grease (Brand: AS2) b) Oil (Brand:)	Lubricating Method	a) Automatic b) Grease gun (cm ³ / min)
Operating Duration	years 6 months	Axial play: 0.1 mm	Seal: standard /

2. Ball Screw Environment (Accessories & Contamination)

Contaminant	Iron particles and washing solution	Contaminant Size	Particle size 30 μm max. -
Cause of Contamination	Does not fall directly on it, but there is a possibility that it could happen. (Please reference with photographs)		
Countermeasures (For already assembled parts, complete after inspection)	a) Telescopic cover -b) Bellow -c) Dust collector -d) Dust-resistant lubricant e) Other () (Please supply drawings to demonstrate dust countermeasures)		

3. Ball Screw Dimensions

Screw Shaft Diameter	Φ 32	Lead	5 mm	Accuracy Grade	C5	Axial Play	Z
Nut Model	ZFRC	Effective Turns of Balls	2.5×2	Direction of Turn	Right	Screw/Overall Length	510 / 750

Remarks
 Request X1 seal

4. Durability Test

Durability test → Scheduled Scheduled to perform functional evaluation for about 2 months.
 → Not scheduled (Reason:)

Ball Screw Use in Contaminated Environments
 ※Please read the below and tick the relevant boxes

An evaluation test result of the special dust-resistant seal which NSK carried out is one case by a particular examination condition (alien substance environment and operating conditions). I accept that the special dust-resistant seal is unable to completely prevent contamination in such an environment and that life may be affected.

In order to improve wear life in contaminated environments, NSK require **dust-proof accessories (covers, lubricating oil, dust collectors, etc)** in addition to the recommended seal exchange.

Ball screw wear life is greatly impacted by contamination entering the nut, offset load from misalignment, as well as lubricating condition. **The final durability comes to need the evaluation confirmation with the actual machine.**

Company Name:	Date:	NSK Ltd. Sales Representative	NSK Ltd. Sales Manager
Department:	Name:	Sign	Sign
Address:	Tel:	Fax:	

NSK Data Sheet for Ball Screws in Contaminated Environments
 (Please copy) 1/1

Model: _____ Location: _____

1. Operating Conditions

Operating Conditions	a) Shaft rotation – nut moving b) Shaft rotation – shaft moving c) Nut rotation – nut moving d) Nut rotation – shaft moving	Stroke in Normal Use	[mm] (Please indicate operating pattern)
		Mounting Orientation	a) Vertical b) Horizontal
Lubricant	a) Grease (Brand:) b) Oil (Brand:)	Lubricating Method	a) Automatic b) Grease gun (cm ³ / min)
Operating Duration	years months	Axial play: mm	Seal: standard /

2. Ball Screw Environment (Accessories & Contamination)

Contaminant		Contaminant Size	Particle size -
Cause of Contamination	(Please reference with photographs)		
Countermeasures (For already assembled parts, complete after inspection)	a) Telescopic cover b) Bellow c) Dust collector d) Dust-resistant lubricant e) Other () (Please supply drawings to demonstrate dust countermeasures)		

3. Ball Screw Dimensions

Screw Shaft Diameter	φ	Lead	mm	Accuracy Grade		Axial Play	
Nut Model		Effective Turns of Balls		Direction of Turn		Screw/Overall Length	/

Remarks

4. Durability Test

Durability test → Scheduled
 → Not scheduled (Reason:)

Ball Screw Use in Contaminated Environments
 ※Please read the below and tick the relevant boxes

An evaluation test result of the special dust-resistant seal which NSK carried out is one case by a particular examination condition (alien substance environment and operating conditions). I accept that the special dust-resistant seal is unable to completely prevent contamination in such an environment and that life may be affected.

In order to improve wear life in contaminated environments, NSK require **dust-proof accessories (covers, lubricating oil, dust collectors, etc)** in addition to the recommended seal exchange.

Ball screw wear life is greatly impacted by contamination entering the nut, offset load from misalignment, as well as lubricating condition. **The final durability comes to need the evaluation confirmation with the actual machine.**

Company Name:	Date:	NSK Ltd. Sales Representative	NSK Ltd. Sales Manager
Department:	Name:	Sign	Sign
Address:	Tel:	Fax:	

B-3-3.7 TW Series for Twin-Drive Systems

(1) Features

Variations in the lead accuracy and preload torque between two ball screws, which consist of a unit of TW Series, are controlled, resulting improved travel accuracy and ball screw operating lifetime.

Fig. 1 shows measured variation in lead accuracy while **Fig. 2** displays an example of variation in thermal expansion between the two ball screws.

Fig. 3 is a schematic diagram comparing the travel accuracy between the TW Series and conventional model.

● High rigidity and long lifetime

Twin-drive systems are superior to single-drive systems in system rigidity, supporting the design of long-life feeding mechanism even if they make the shaft diameter one size smaller.

● High responsiveness to positioning commands
Twin-drive systems permit the use of screw shaft diameters that are one size smaller, thereby reducing screw shaft inertia by up to 50%, offering high responsiveness to positioning commands.

● Improved high-speed capability and noise level
Twin-drive systems allow the use of smaller screw diameters, resulting in no increase in the level of noise. The end-deflector recirculation system significantly improves high-speed capability and noise level compared with the existing return tube recirculation system, offering high-speed feeding of up to 1 200 mm/min (shaft dia. 40 mm, lead 30 mm, rotational speed 4 000 min⁻¹).

(2) Specifications

Table 1 Specifications of twin-drive systems

Recirculation systems	End-deflector recirculation system, Return tube system, Deflector(bridge type) system
Shaft dia.	32 – 63 mm
Lead	10 – 30 mm
Accuracy grade	C5
Screw shaft length	3 m or less

(3) Optional specifications

- Hollow shaft ball screw and nut cooling ball screw
- Provides high accuracy through the use of forced cooling. Please refer to ball screws for high precision machine tools (page B544 to B552) for more details.

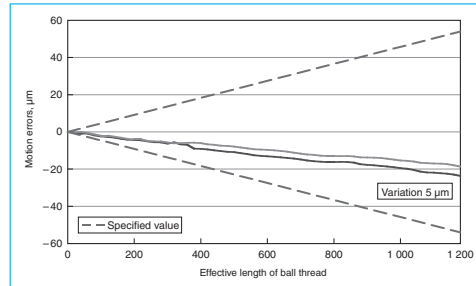

Fig. 1 Example of measured variation in lead accuracy

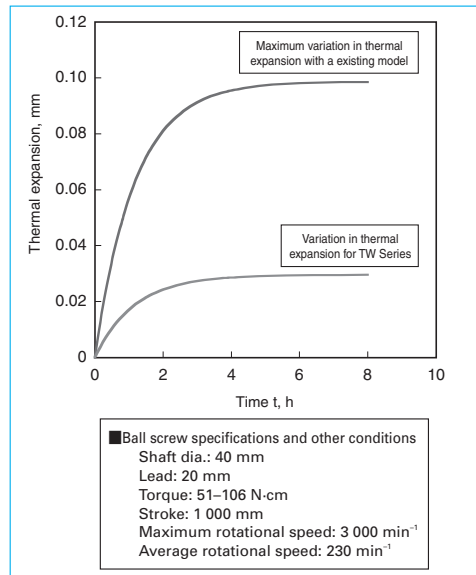

Fig. 2 Calculation example of the variation of thermal expansion

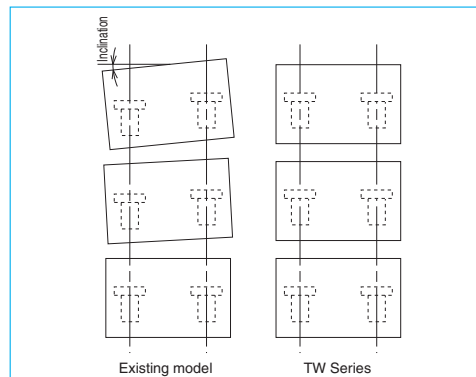

Fig. 3 Schematic diagram of travel accuracy

B-3-3.8.1 Hollow Shaft Ball Screw for High Precision Machine Tools

The increase in speed of the feeding mechanism for highly accurate positioning may require some measures against thermal expansion of the ball screw (forced cooling using hollow ball screw). NSK standardized hollowed screw shafts and shaft ends configuration (sealing section and support bearing seat). NSK recommends this as the most effective measure against thermal expansion.

1. Features

● Stable positioning accuracy
Suppresses expansion of the ball screw shaft by rising temperature, and provides stable, precise positioning.

● Prevents displacement of various sections
Minimizes deformation of the ball screw support bearings as well as of the machine base which is caused by thermal expansion of ball screw. Forced cooling keeps the heat from spreading to other sections, and prevents the processing table from deforming due to heat.

● Reduces warm-up time
Temperature does not rise high, therefore cuts machine warm-up period.

● Maintains lubricant's effect
Removes heat from the ball screw, deterring lubricant deterioration.

● Easy designing for installation
Use support bearing unit exclusive for NSK ball screws (high speed and high load capacity for machine tools, see page B405) and seal unit (page B547) to standardized shaft end. This makes designing of mounting ball screw easy. NSK also provides nut cooling ball screws. The level of temperature rise for nut cooling ball

screw is equal to the hollow shaft ball screw thanks to the optimized nut internal design for cooling. Please refer to nut cooling ball screws (page B549) for more details.

2. Design precautions

Refer to HMC type, end-deflector recirculation system, return tube recirculation system, and deflector(bridge type) recirculation system for ball screw specifications. If the overall ball screw length exceeds 3 000 mm, contact NSK. For general precautions regarding ball screw, refer to "Design Precautions" (page B83) and "Handling precautions" (page B103).

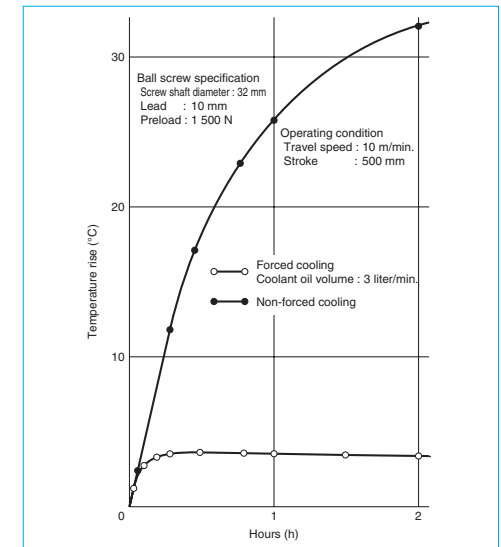
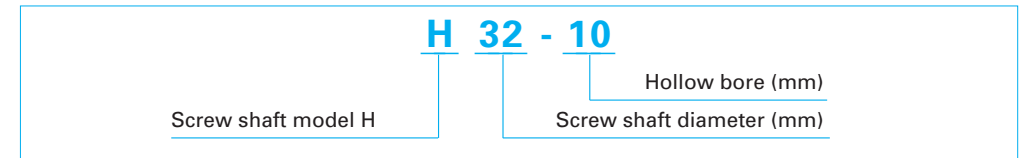

Fig. 1 Effect of forced cooling by hollow shaft ball screw

3. Model example of dimension table

A model number that indicates specification factors is structured as shown below.

◇Example of model



4. Installation example and standard dimensions

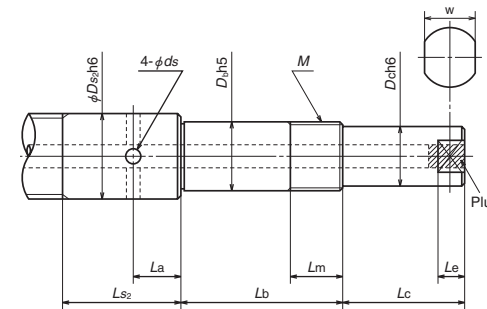
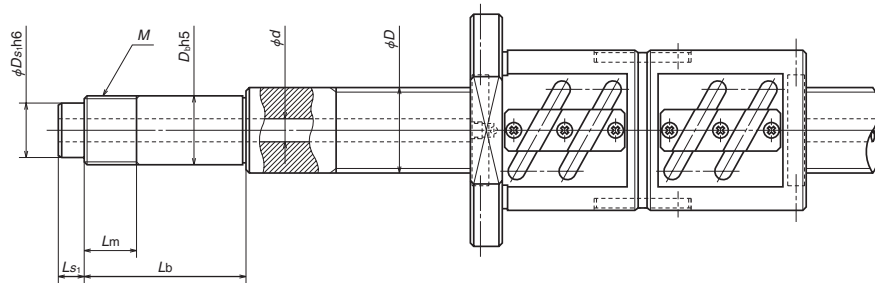
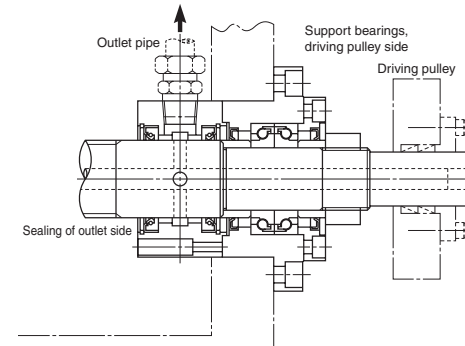
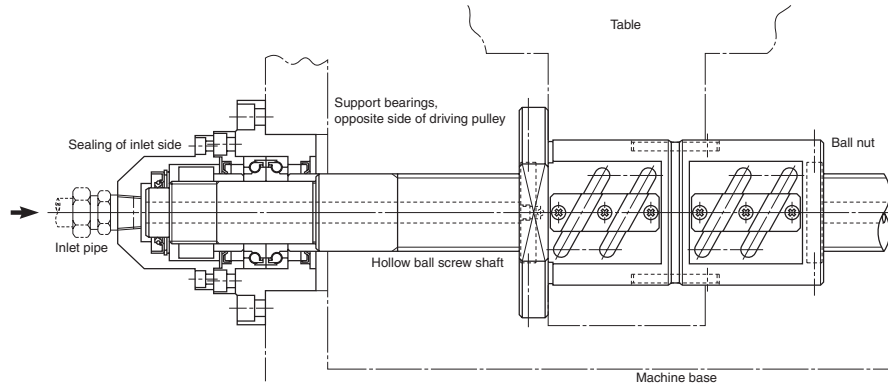

Model No.	Screw shaft		Bearing seat				Sealing					
	Diameter D	Hollow d	Diameter Db	Lock nut			Inlet		Outlet			
				M	Lm	Lb	Ds ₁	LS ₁	Ds ₂	LS ₂	La	ds
H32-10	32	10	25	M25×1.5	26	89	20	15	32	60	25	6
				104								
				119								
H40-12	40	12	30	M30×1.5	26	89	25	15	40	60	25	7
				104								
				119								
H50-15	50	15	40	M40×1.5	30	92	32	15	50	65	27	8
				107								
				122								

Notes: 1. Please consult NSK for other models.
2. See B416 for bearing combination symbols.

Drive side		Spanner flats		Applicable support unit	Used bearing	Equipped seal unit	
Dc	Lc	w	Le			Shaft end	Shaft outer surface
20	40	17	8	WBK25DF-31H	25TAC62CSUHPN7C DF combination	WSK20A-01	WSK32B-01
				WBK25DFD-31H	25TAC62CSUHPN7C DFD combination (25TAC62CSUHPN7C DFF combination)		
25	50	22	10	WBK30DF-31H	30TAC62CSUHPN7C DF combination	WSK25A-01	WSK40B-01
				WBK30DFD-31H	30TAC62CSUHPN7C DFD combination (30TAC62CSUHPN7C DFF combination)		
35	70	30	13	WBK40DF-31H	40TAC72CSUHPN7C DF combination	WSK32A-01	WSK50B-01
				WBK40DFD-31H	40TAC72CSUHPN7C DFD combination		
				WBK40DFF-31H	40TAC72CSUHPN7C DFF combination		

Unit: mm

5. Seal units for hollow ball screw shaft (available by order)

This is an exclusive joint for coolant of the hollow ball screw shaft.

**A Type
(for shaft end)**

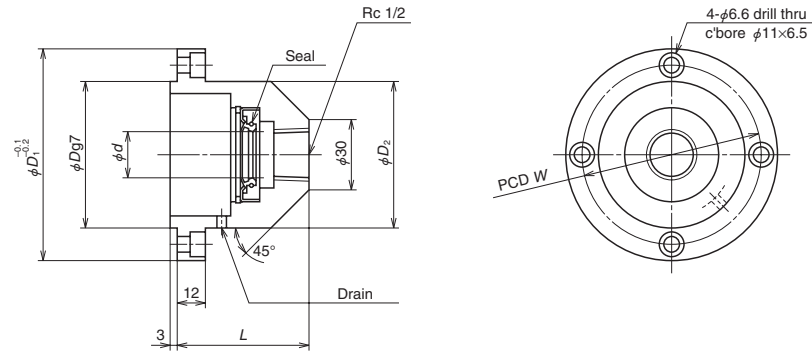

Unit: mm

Reference No.	d	D	D ₁	D ₂	L	W	Fixing bolt
WSK20A-01	20	57	85	57	56	70	M6
WSK25A-01	25	57	85	57	56	70	M6
WSK32A-01	32	69	95	67	61	80	M6

**B Type
(for shaft outer surface)**

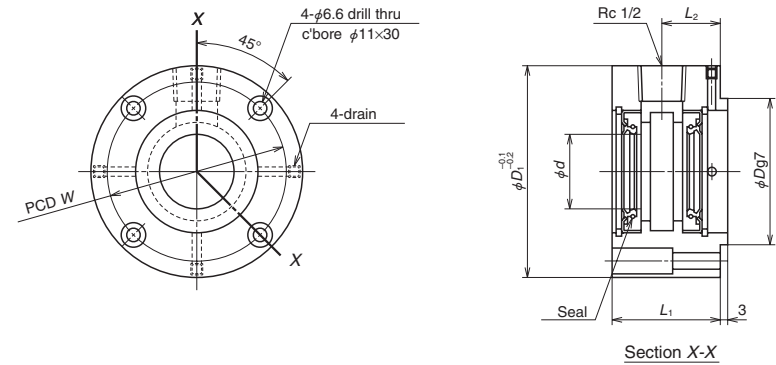

Unit: mm

Reference No.	d	D	D ₁	L ₁	L ₂	W	Fixing bolt
WSK32B-01	32	57	85	46	25	70	M6
WSK40B-01	40	57	85	46	25	70	M6
WSK50B-01	50	69	95	49	27	80	M6

◇ **Handling precautions**

- Use NSK support unit (high speed and high load capacity for machine tools on page B405) for installation in order to maintain the eccentricity between screw shaft and seal unit.

- Apply grease to the lip section for protection at the time of installation to the ball screw.
- Make certain that the drain holes (one for A Type, four for B Type) of the seal unit directly face downward when the unit is installed.

B-3-3.8.2 Nut Cooling Ball Screws for High Precision Machine Tools

Nut cooling ball screws are easily cooled with a ball nut cooling system and are ideal for use in high-speed and high-precision machine tools that have nut cooling systems.

Using nut cooling ball screws makes it possible to cool long ball screws that are difficult to cool with hollow-core cooling, and they accommodate the broad high-precision needs of machine tools both small and large.

1. Features

● Cooling effects

By optimizing the cooling structure inside the nut, cooling capacity equivalent to hollow shaft cooling has been achieved. The nut in contact with the table is cooled, so that heat conduction from the table to the ball screw is blocked. Moreover, by cooling hollow shaft in parallel, the screw shaft and ball nut can be cooled at the same time for even more precise temperature control.

● Internal design in consideration of preload torque change

The nut cooling ball screw has double contact-point preload in the tensile direction. This prevents an increase in preload torque when the nut is cooled, enabling effective cooling of the ball screw.

● Cooling structure

The cooling fluid goes in a balanced way through the nut. Double nuts have separate coolant routes for each nut for efficient cooling. Cooling fluid does not go through the inside of spacers, so coolant fluid does not leak even when preload drops and airtightness is maintained.

● Improved handling

Ball screws can be cooled by simply attaching piping to the exterior flange part.* Sliding seals and rotary joints that are required for hollow shaft cooling are not needed. Dimensions for mounting area (without nut cooling) are the same as conventional products, so the nut cooling can be implemented without changing machine designs.

*When cooling double nuts, piping is required on the nut end face on the other side of the flange.

● Long ball screws can be cooled at a low cost
 Since these products are suitable for long ball screws for which hollow hole processing is difficult, improved precision of large machine tools can be achieved at a low cost.

2. Cautions regarding design

If heat impact from the bearing is too great, separate cooling for bearing and surrounding areas is recommended. For details, please contact NSK.

◇Reference number for nut cooling ball screw

W4012-ZMNC-C5Z20**

Nut cooling ball screw code

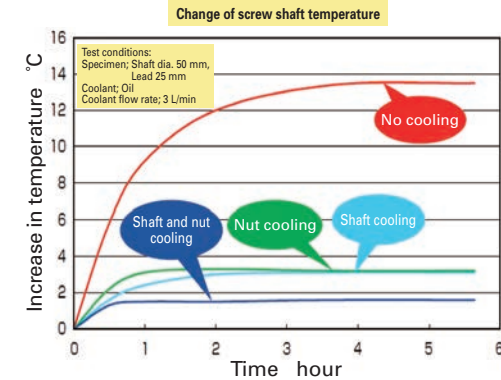

Fig. 1 Effect of forced cooling by nut cooling ball screw

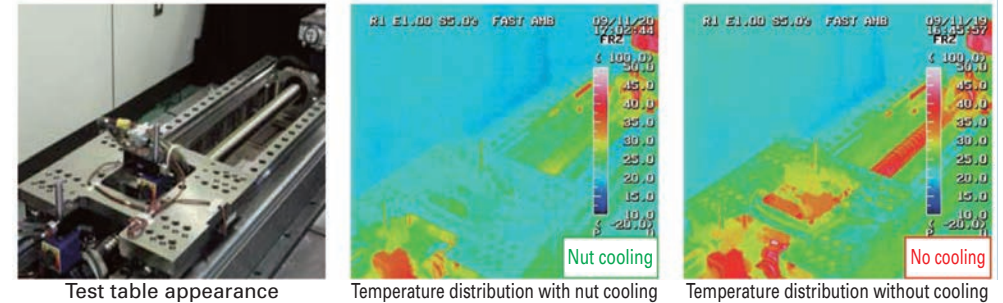
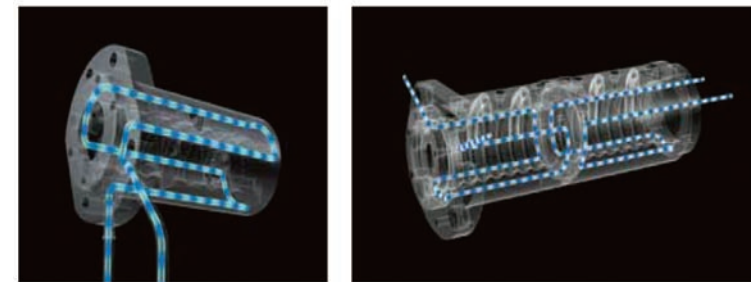

Fig. 2 Effect of forced cooling by nut cooling ball screw

Cooling structure



Single nut

Double nut

Fig. 3 Cooling structure of a nut cooling ball screw

Nut cooling ball screws: dimension chart

● Single nut cooling ball screws (for HMD type, nut type: EM)

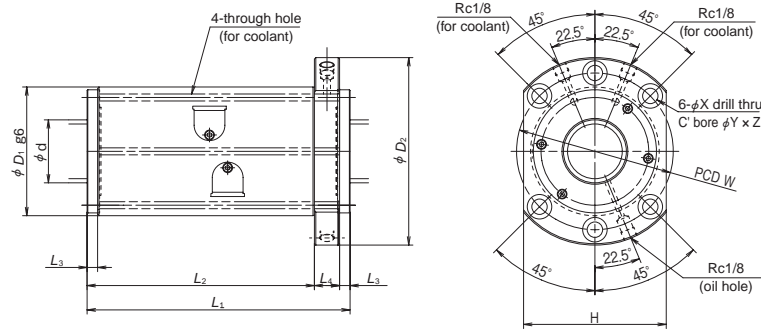

● Double nut cooling ball screws (tube-type, nut type: DFT)

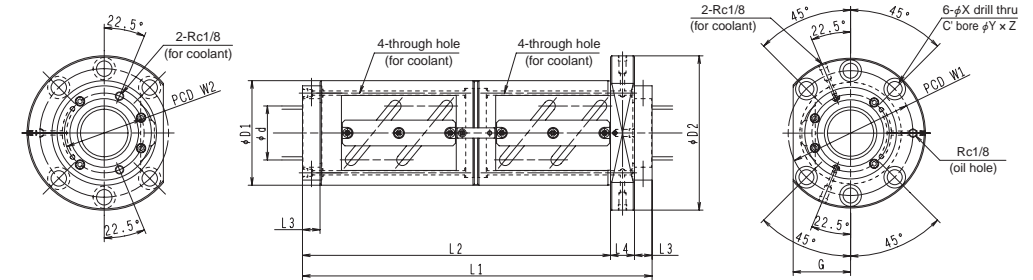

Applicable dimensions for HMD type

Unit: mm

Model No.	Shaft dia. <i>d</i>	Lead <i>l</i>	Nut dimensions										
			<i>D</i> ₁	<i>D</i> ₂	<i>H</i>	<i>L</i> ₁	<i>L</i> ₂	<i>L</i> ₃	<i>L</i> ₄	<i>W</i>	<i>X</i>	<i>Y</i>	<i>Z</i>
EM4016-4E	40	16	86	128	96	166	140.5	7.5	18	106	11	17.5	11
EM4020-6E		20				156	130.5						
EM4025-6E		25				188	162.5						
EM4030-6E		30				219	193.5						
EM4516-4E	45	16	92	134	102	166	140.5	7.5	18	112	11	17.5	11
EM4520-6E		20				156	130.5						
EM4525-6E		25				188	162.5						
EM5016-4E	50	16	98	140	107	166	140.5	7.5	18	118	11	17.5	11
EM5020-6E		20				156	130.5						
EM5025-6E		25				188	162.5						
EM5030-6E		30				219	193.5						
EM6316-4E	63	16	122	180	138	176	139	9	28	150	18	26	17.5

Dimensions for tube type

Unit: mm

Model No.	Shaft dia. <i>d</i>	Lead <i>l</i>	Nut dimensions												
			<i>D</i> ₁	<i>D</i> ₂	<i>L</i> ₁	<i>L</i> ₂	<i>L</i> ₃	<i>L</i> ₄	<i>G</i>	<i>W</i> ₁	<i>X</i>	<i>Y</i>	<i>Z</i>	<i>W</i> ₂	
DFT5010-7.5	50	10	93	135	303	275	10	18	51	113	11	17.5	11	73	
DFT5012-5		12	100	146	279	245	12	22	55	122	14	20	13	78	
DFT5016-5		16	100	146	344	306	16	22							
DFT5020-3		20	100	146	327	279	20	28							
DFT5510-5	55	10	102	144	243	215	10	18	54	122	11	17.5	11	80	
DFT6310-7.5	63	10	108	154	307	275	10	22	58	130	14	20	13	88	
DFT6312-5		12	115	161	279	245	12	22	61	137	14	20	13	91	
DFT6316-5		16	122	180	350	306	16	28	69	150	18	26	17.5	93	
DFT6320-5		20	122	180	407	359	20	28							
DFT8010-5	80	10	130	176	247	215	10	22	66	152	14	20	13	108	
DFT8012-5		12	136	182	279	245	12	22	68	158	14	20	13	110	
DFT8016-5		16	143	204	350	306	16	28	77	172	18	26	17.5	112	
DFT8020-5		20	143	204	407	359	20	28							
DFT10012-5	100	12	160	220	285	245	12	28	82	188	18	26	17.5	134	
DFT10016-5		16	170	243	354	306	16	32	91	205	22	32	21.5	136	
DFT10020-5		20	170	243	411	359	20	32							

B-3-3.9 ND Series for Nut-Rotatable Drives

• This product is patented by NSK.

A nut rotatable ball screw is developed as a unit into which angular contact support ball bearings are integrated. It is best suited for an application that requires rotation of the ball nut while the screw shaft is fixed.

NDT model

1. Structure

Balls are installed between the assembly housing and the ball nut. The outer bearing rings are integrated into the assembly housing and thus, compact design are attained.

A timing pulley (prepared by the user) is directly secured to the end face of the nut.

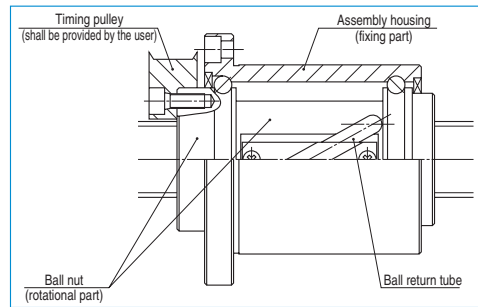

Fig. 1 Ball nut structure

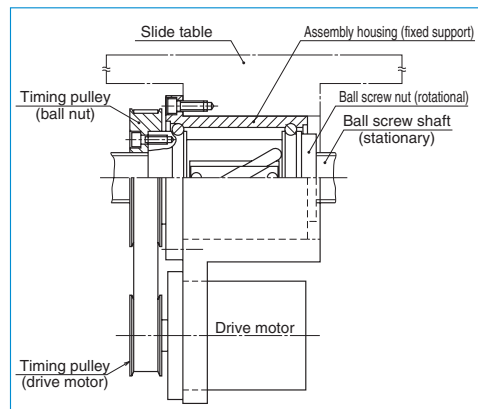

Fig. 2 Example of installation to the table

2. Features

● Multi-nut drive

Two or more nut units can be installed in a single ball screw shaft. They can be operated by respective motors.

● High operation speed

High feeding speed operation, but yet low rotational speed, is feasible by means of medium to high-helix lead ball screws.

● Easy installation

Merely install a mount housing to the table of the machine to take advantage of this multi-nut rotation system.

● Simple shaft end configuration

Shaft end configuration is simple because this unit does not need support bearings.

● Shaft diameter/lead combination

There are 10 types of "shaft diameter/lead" combinations.

Selections are: Shaft diameters -- 32, 40, 50 mm; Leads -- 20, 25, 32, 40, 50 mm.

● Low inertia

Compared to the NSK current product (end cap ball recirculation system), rotational inertia was reduced by 16% at most.

3. Specifications

(1) Ball recirculation system

The structure of return tube recirculation system is shown below.

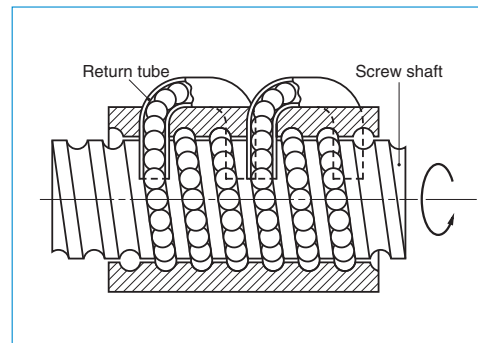

Fig. 3 Structure of ball return tube recirculation system

(2) Accuracy grade and axial play

The available standard accuracy grade and axial play are as follows. Please consult NSK for other grades.

Table 1 Axial play

Axial play code	Z	T	S
Axial play	0	0.005 mm or less	0.020 mm or less

Table 2 Combination of accuracy grades and axial play

Accuracy grade	C3	C5	Ct7
Axial play code	Z, T, S	Z, T, S	S

4. Allowable d·n value and the criterion of maximum rotational speed

Allowable d·n value and the criterion of maximum rotational speed are shown below. Please consult NSK if the rotational speed exceeds the permissible range below.

Note: The basic concept is the same as that of general ball screws. Refer to "Technical Description: Permissible Rotational Speed" (page B47).

Table 3 Allowable d·n value and the criterion of maximum rotational speed

Allowable d·n value	Standard specification	70 000 or less
	High-speed specification	100 000 or less
Criterion of maximum rotational speed	3 000 min ⁻¹	

d·n value: shaft dia. d [mm] × rotational speed n [min⁻¹]

● Critical speed n_c

As shown Fig. 4, calculate unsupported length (mm) of L_1 , L_2 , and L_3 (assumed that the nut section is a fixed support.) Table 4 shows the coefficients "f" of each shaft end mounting condition.

$$n_c = f \cdot \frac{d_r}{L_i^2} \times 10^7 \text{ (min}^{-1}\text{)} \quad \text{(III-1)}$$

d_r : Screw shaft root diameter (See the dimension table.)

L_i : Unsupported length (mm) (See Fig. 4)

f: Factor determined by the ball screw shaft end mounting condition

Table 4

Shaft end mounting condition	f
Fixed – Fixed support	21.9
Fixed – Simple support	15.1
Fixed – Free support	3.4

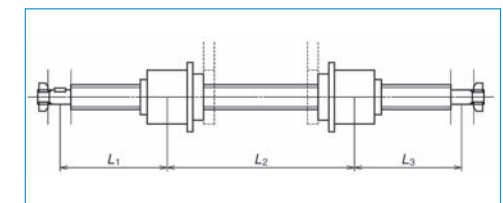

Fig. 4 Installation example

5. Design precautions

One end of the screw thread should be cut-through to the end. Also, if the nut must be removed from the screw shaft, the user should have an arbor to prevent the balls from falling out during this process. (NSK manufactures arbors on request.)

For general precautions regarding ball screws, refer to "Design Precautions" (page B83) and "Handling Precautions" (page B103).

NDD Type: (Incorporating vibration damper)

An increase in stroke length may restrict required rotational speed of a ball screw due to the issue of critical speed even if there is no problem on d·n limitation.

In such a case, we recommend using NDD Type nut rotatable ball screws equipped with vibration damper.

It will make it possible to operate a ball screw exceeding the critical speed, which is conventionally considered being impossible.

Notes: 1) However, NDD Type cannot be used exceeding the d·n limitation. Please consult with NSK in such a case.

2) You cannot rotate the screw shaft of NDD Series.

1. Structure

Hollow ball screw shaft has a mechanism to absorb vibration energy (vibration damper). This increases dynamic rigidity of the screw shaft and lowers vibration when exceeding the critical speed.

Construction of the ball nuts are the same as those of NDT Type.

2. Features

- No need for measures against critical speed. Conventionally, an increase in screw shaft diameter or use of intermediate support is the measure against the issue of critical speed. NDD Type ball screw will make these measures needless.

- Dimensional interchangeability with NDT Type ball screws

The vibration damper is set inside a ball screw shaft, and therefore, there is no difference with existing series in regards to external dimensions. The ball nuts of NDD Type are interchangeable with those of NDT Type.

- Others

Benefits in multiple ball nut on a screw shaft, high feeding speed for long stroke, easy in installation, and low inertia of the ball nuts are the same as NDT Type.

3. Specification

Recirculation system, accuracy grade, axial play and preload system are the same as NDT Type.

4. Design precautions

They are the same as NDT Type.

5. Permissible rotational speed

The d·n value is the same as NDT Type. You don't need to consider the critical speed.

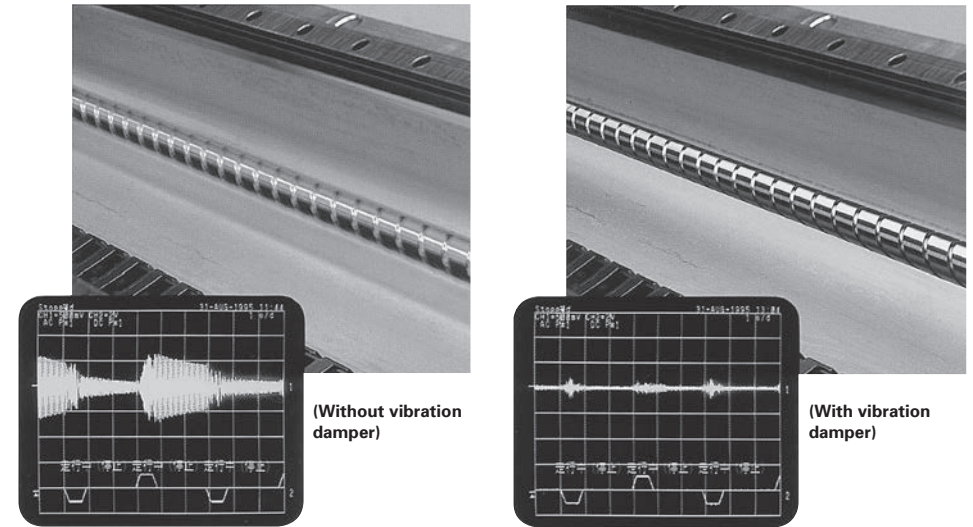

Fig. 6 Vibration of screw shaft when nut is rotating

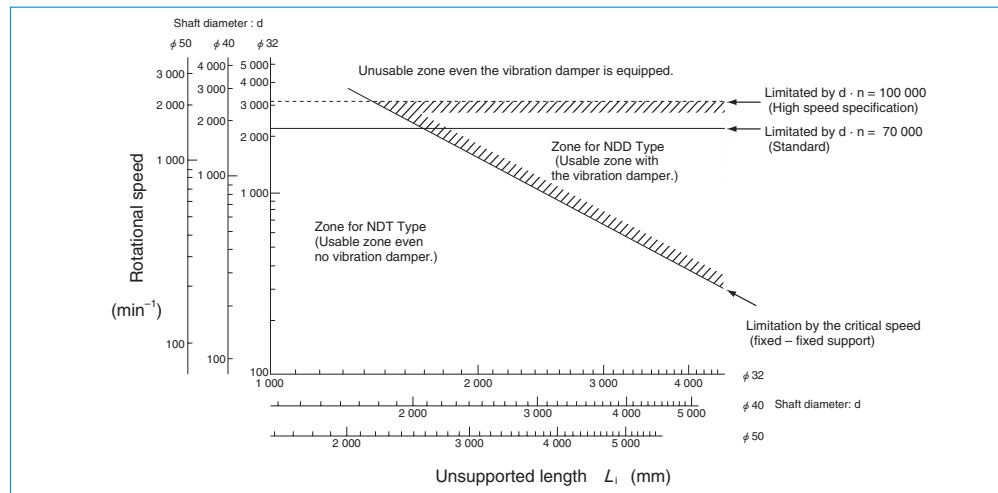

Fig. 5 Compartmentalization between NDT and NDD types to rotational speed and unsupported length

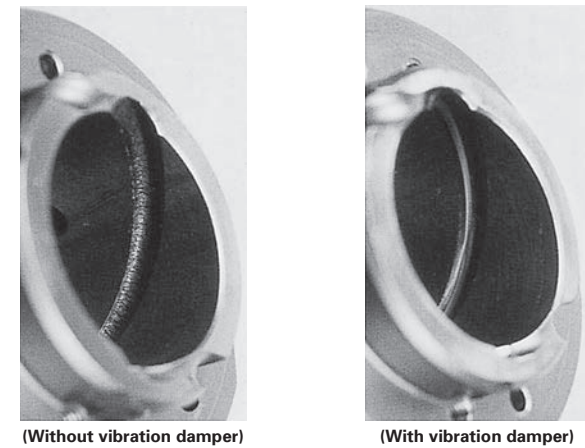

Fig. 7 Effect of vibration damper (results of endurance test)

Calculation example of permissible rotational speed

[Calculation example]

Assume a system which moves two nuts on a shaft as shown below.

Does this system operate appropriately if: both ends of the ball screw (shaft diameter 40 mm/lead 40 mm) are fixed, and the travel speed is at 60 m/min?

[Answer]

The rotational speed n (min^{-1}) when the lead of the ball screw is 40 mm, and the travel speed is at 60 m/min is:

$$n = \frac{60 \times 10^3}{40} = 1\,500 \text{ (min}^{-1}\text{)}$$

● Calculate $d \cdot n$ value

As the $d \cdot n$ value of standard specification is 7 000, therefore, the permissible rotational speed is;

$$n \leq \frac{70\,000}{40} = 1\,750 \text{ (min}^{-1}\text{)}$$

● Calculate critical speed

The maximum unsupported length comes between Nut A and B.

$$L_2 = 3\,300 \text{ (mm)}$$

$$f = 21.9 \text{ (Fixed-Fixed)}$$

$$\text{Root diameter: } d_r = 35.1 \text{ (mm)}$$

Therefore, the permissible rotational speed is;

$$n \leq \frac{21.9 \times 35.1}{3\,300^2} \times 10^7 = 706 \text{ (min}^{-1}\text{)}$$

The calculation indicates that the $d \cdot n$ value is at the safe level. But the critical speed exceeds the limitation. However, with a vibration damper, the system can be operated at 1 500 min^{-1} .

Structure of reference number

The followings describe the structure of "Reference number for ball screw".

◇Reference number for ball screw

W 40 15 - ** P XU - C5 Z 40	
Product code	Lead (mm)
Screw shaft diameter (mm)	Axial play code: Z, T, S (page B20)
Effective threaded length (in the unit of 100 mm)	Accuracy grade: C3, C5, C7 (Ct7) (page B37 to B42)
Design serial number	Appearance/specification code ("T" is added for NDD Type.)
Preload code: No code, Non-preload; P, P-preload (page B5)	

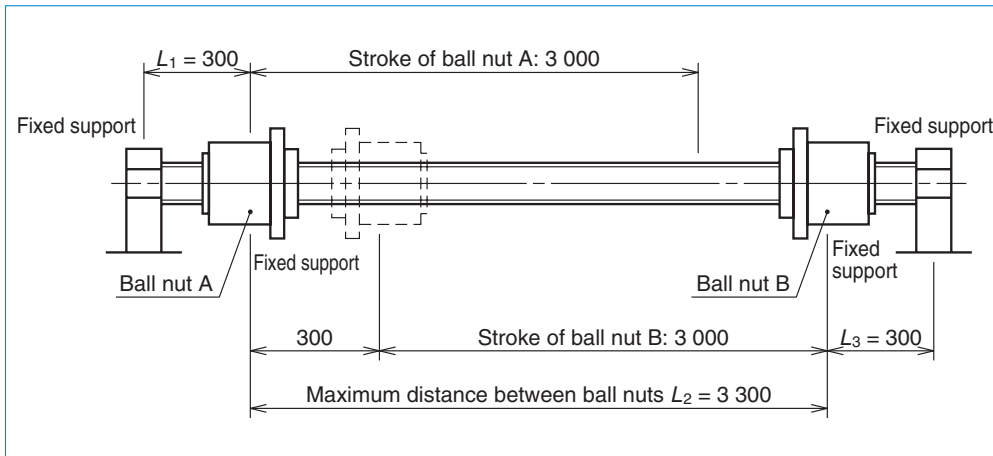
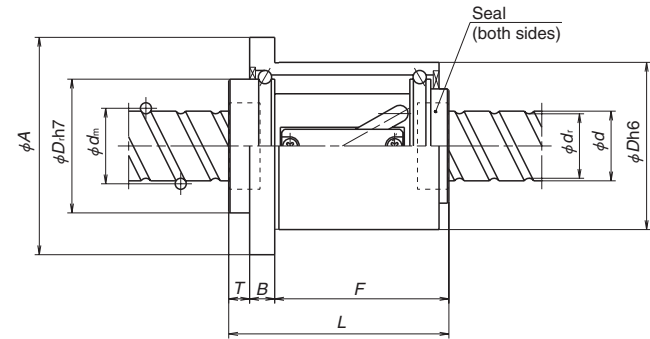
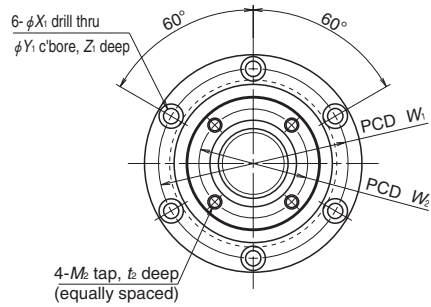

Fig. 8 Calculation example of permissible rotational speed



Unit: mm

Model No.	Shaft dia. d	Lead l	Ball dia. D_w	Ball circle dia. d_m	Root dia. d_r	Effective turns of balls Turns × Circuits	Basic load rating (N)		Moment of inertia, ball nut J ($\text{kg}\cdot\text{cm}^2$)	Ball nut mass W (kg)
							Dynamic C_d	Static C_{0a}		
NDT NDD 3220-2.5	32	20	4.762	33.25	28.3	2.5×1	17 900	41 800	6.2	2.9
NDT NDD 3225-2.5		25	4.762	33.25	28.3	2.5×1	17 900	41 800	6.7	3.2
NDT NDD 3232-1.5		32	4.762	33.25	28.3	1.5×1	11 500	24 800	6.2	2.9
NDT NDD 3232-3						1.5×2	18 900	44 600		
NDT NDD 4025-2.5		40	25	6.35	41.75	35.1	2.5×1	28 500	70 000	19.3
NDT NDD 4032-1.5	32		6.35	41.75	35.1	1.5×1	18 400	41 200	18.0	5.5
NDT NDD 4032-3						1.5×2	30 100	74 100		
NDT NDD 4040-1.5	40		6.35	41.75	35.1	1.5×1	18 400	41 200	19.2	6.0
NDT NDD 4040-3						1.5×2	30 100	74 100		
NDT NDD 5025-2.5	50	25	7.938	52.25	44.0	2.5×1	42 700	109 000	45.7	8.5
NDT NDD 5032-2.5		32	7.938	52.25	44.0	2.5×1	42 700	109 000	48.9	9.4
NDT NDD 5040-1.5		40	7.938	52.25	44.0	1.5×1	27 500	66 500	45.5	8.5
NDT NDD 5040-3						1.5×2	44 900	120 000		
NDT NDD 5050-1.5		50	7.938	52.25	44.0	1.5×1	27 500	66 500	48.7	9.4
NDT NDD 5050-3	1.5×2					44 900	120 000			

Notes: 1. The right hand screw is the standard. Consult NSK for the left hand screws.
2. Seals are standard equipment.

Ball nut dimensions													Tap hole PCD W_2
Nut entire length L	Nut outside diameter D	Flange outside diameter A	Flange width B	Nut length F	Projection tube dimensions D_r , T		Bolt hole dimensions X_1 , Y_1 , Z_1			Bolt hole PCD W_1	Tap hole dimensions M_2 , t_2		
107	78	105	12	83	60	12	6.6	11	6.5	91	M6	12	50
120	78	105	12	96	60	12	6.6	11	6.5	91	M6	12	50
107	78	105	12	83	60	12	6.6	11	6.5	91	M6	12	50
136	100	133	15	106	76	15	9	14	8.5	116	M8	16	62
122	100	133	15	92	76	15	9	14	8.5	116	M8	16	62
136	100	133	15	106	76	15	9	14	8.5	116	M8	16	62
140	120	156	18	107	96	15	11	17.5	11	136	M10	18	78
158	120	156	18	125	96	15	11	17.5	11	136	M10	18	78
140	120	156	18	107	96	15	11	17.5	11	136	M10	18	78
158	120	156	18	125	96	15	11	17.5	11	136	M10	18	78

ND Series

B-3-3.10 Σ Series for Robots

1. Features

Σ Series (NSK's Robotte) is a ball screw with a high-performance spline. It is ideal for various actuators such as the vertical axis of SCALA type robot.

A ball screw groove and a ball spline groove are made in one shaft, combining the ball screw and the ball spline.

Mount housing, nuts, and support bearings are combined into a single unit.

Timing pulley (prepared by the user) is directly secured at the end face of the nut.

● High functions

A single shaft has both feeding mechanism and guide functions. This allows the shaft ends to move back and forth (linear motion), as well as to rotate.

● Compact and lightweight

A ball screw nut and a spline nut are placed on one shaft, and a support bearings are also combined to the unit. This allows compact and high-precision design. Hollow shaft is standard to reduce weight. The hollow can be used for wiring and piping. Other components are also designed to be light in weight.

● Low inertia

Because of return tube type ball nut of which outside diameter is decreased, low inertia design is enabled.

It reduces the inertia by 19% of conventional products.

2. Functions

As shown in Fig. 1, the ball screw nut and a spline nut are rotated independently to control rotation value. Thereby the shaft can move in any direction -- linear and rotational. Table 1 shows the relationship between power input and output.

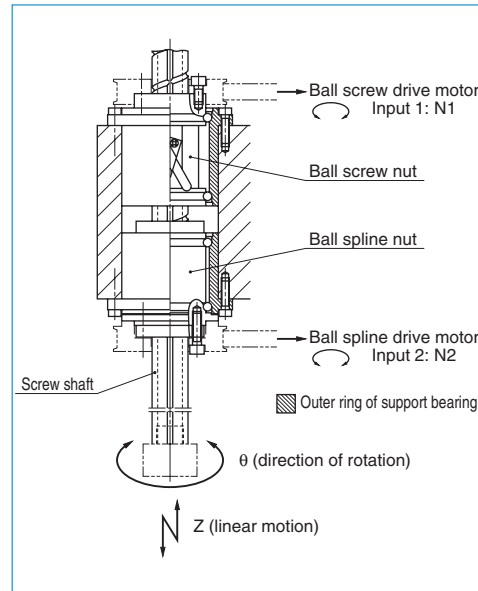

Fig. 1 Example structure of Z axis plus θ axis actuator

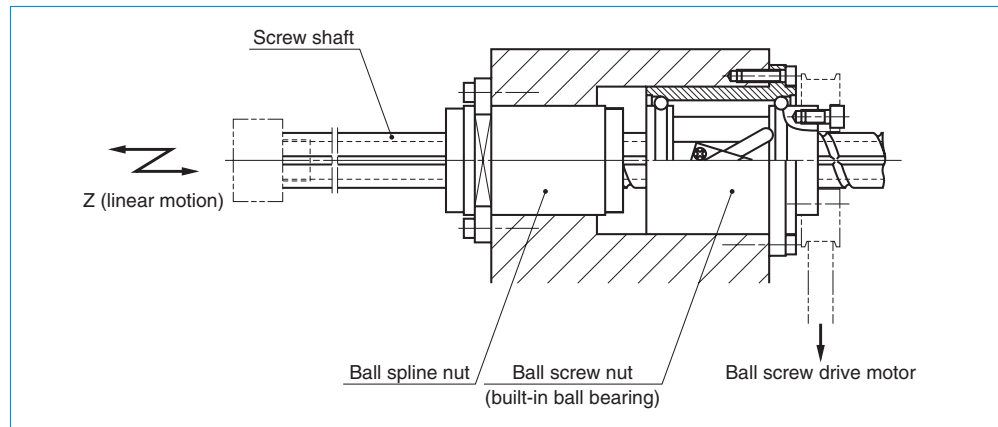

Fig. 2 Example structure of single Z axis unit

Table 1 Power input and output of Σ Series

Shaft movement (output)		Input		
Z (up-down movement) (mm/min)	θ (rotational movement) (min^{-1})	① Ball screw (min^{-1})	② Spline (min^{-1})	Notes
Up, down $N1 \times l$	Stop 0	Rotate N1	Stop 0	-
Stop 0	Rotate N2	Rotate N1	Rotate N2	$N1 = N2$
Up, down $N2 \times l$	Rotate N2	Stop 0	Rotate N2	-
Up, down $ N1-N2 \times l$	Rotate N2	Rotate N1	Rotate N2	$N1 \neq N2$

3. Specifications

(1) Ball recirculation system

A structure of return tube recirculation system is shown below.

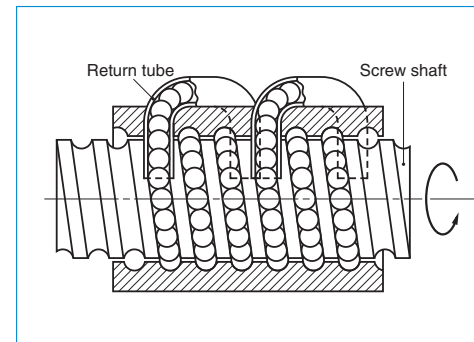

Fig. 3 Structure of return tube recirculation system

(2) Accuracy grade and axial play

The available standard accuracy grade and axial play for ball screw are as follows. The axial play for spline is 0 mm (preloaded product). Please consult NSK for other grades.

Table 2 Accuracy grade and axial play

Accuracy grade	C3, C5, Ct7
Axial play	Z, 0 mm (preloaded) T, 0.005 mm or less; S, 0.020 mm or less

(3) Allowable d·n value and the criterion of maximum rotational speed

Allowable d·n value and the criterion of maximum rotational speed are shown below. Please consult NSK if the rotational speed exceeds the permissible range below.

Permissible d·n value: 70 000 or less

Criterion of maximum rotational speed: 3 000 min^{-1}

Note: Please also review the critical speed.

For details, see "Technical Description: Permissible Rotational Speed" (page B47).

(4) Application

SCALA type and Cartesian type industrial robots, semiconductor manufacturing machines, machines for automobile production facilities, material handling systems, other Z (vertical) axis and Z axis plus θ (rotation) axis actuators.

4. Design precautions

The overall length L can be extended to 25 times of the shaft diameter.

To remove the spline nut from the shaft for assembling, use an arbor as shown in Fig. 4. (page B545). Avoid removing ball screw nut as much as possible. Refer to root diameter in the dimension table for arbor diameter. (NSK manufactures the arbors on request.)

For general precautions regarding ball screws, refer to "Precautions in Designing" (page B83) and "Precautions in Handling" (page B103).

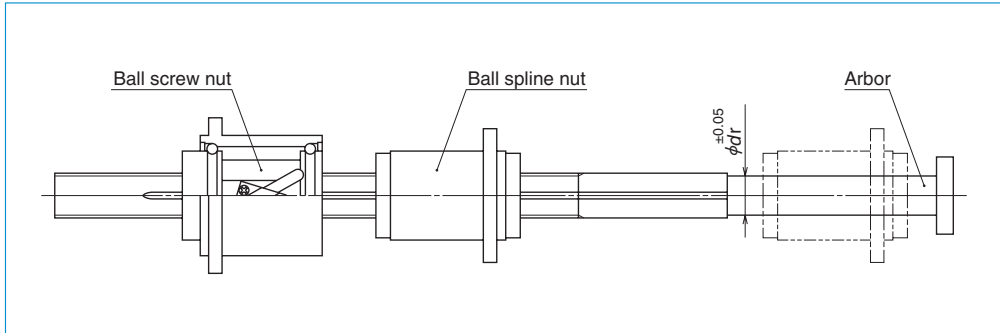

Fig. 4 Removing spline nut

5. Product categories

Σ Series (NSK's Robotte) is four models with different moving functions and performances are available. Select a standard model if rigidity is important. A compact system is recommended for reducing the weight of machine.

Table 3 Σ Series product categories

Model	Appearance	Size	Structure (Movement)
Σ		Standard	Z+ θ Unit
ΣZ		Standard	Z Unit
ΣC		Compact	Z+ θ Unit
ΣCZ		Compact	Z Unit

6. Load rating and life

The relationship between load rating of the ball spline section and life is the same as in other NSK liner motion products. However, various loads that apply to Robotte must be taken into account. For example, the following factors must be considered in calculating life when the product is used as shown in Fig. 5.

- Fa : Load that is generated when the shaft moves in up-down direction. (Load is applied to the ball screw nut.)
- T : Torque that is generated to the shaft by Fa.
- Fr : Load that is generated by moment of inertia of the shaft and the work attached to Robotte as well as by centrifugal force when the arm rotates.
- θ : Direction of Fr load that changes by shaft rotation.

NSK has life calculation programs which take these factors into account. Please ask NSK for more details.

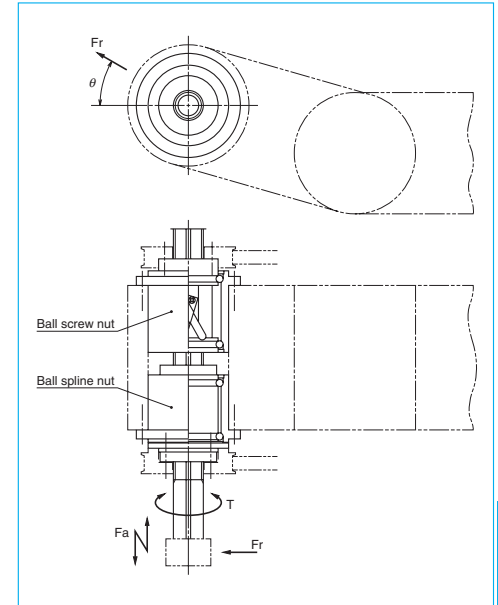

Fig. 5 Example structure of Z axis plus θ axis actuator

7. Structure of reference number

The following describes the structure of "Reference number for ball screw".

◇Reference number for ball screw

PW 25 02 - ** P T U - C5 Z 20

Product code	Screw shaft diameter (mm)	Effective threaded length (in the unit of 100 mm)	Design serial number	Preload code: No code, Non-preload; P, P-preload (page B5)	Lead (mm)
					Axial play code: Z, T, S (page B20)
					Accuracy grade: C3, C5, C7 (Ct7) (page B37 to B42)
					Use support unit
					Hollow shaft ball screw specification

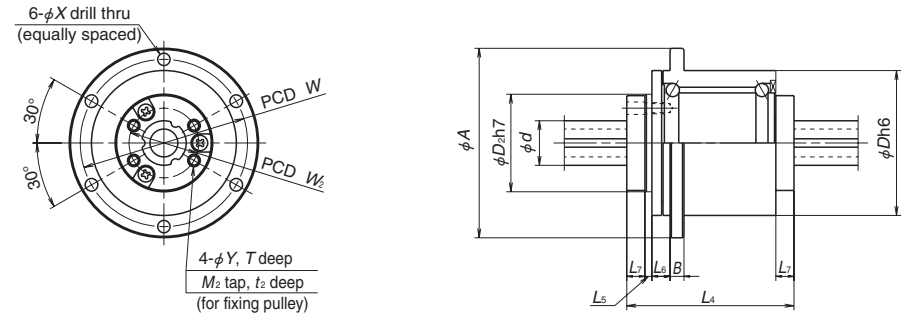
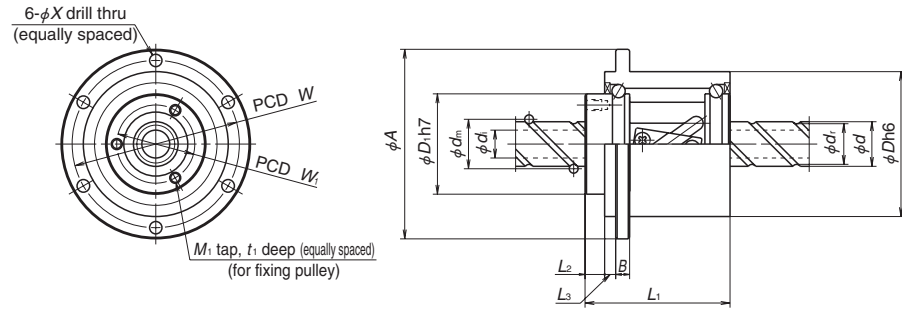

Unit: mm

Model No.	Shaft dia. <i>d</i>	Lead <i>l</i>	Ball dia. <i>D_w</i>	Ball circle dia. <i>d_m</i>	Root dia. <i>d_r</i>	Screw shaft hollow <i>d_i</i>	Ball screw nut															Moment of inertia (kg·cm ²)
							Basic load rating (N)		Dimensions											X		
							Dynamic <i>C_a</i>	Static <i>C_{0a}</i>	<i>D</i>	<i>A</i>	<i>B</i>	<i>L₁</i>	<i>L₂</i>	<i>L₃</i>	<i>M₁</i>	<i>t₁</i>	<i>W₁</i>	<i>D₁</i>	<i>W</i>			
Σ1610	16	10	3.175	16.75	13.4	(8)	4 710	8 110	48	64	5	47	7	4	3-M4	6	28	35	56	4.5	0.41	
Σ1632	16	32	3.175	16.75	13.4	(8)	2 990	4 870	48	64	5	52	7	4	3-M4	6	28	35	56	4.5	0.44	
Σ2010	20	10	3.175	20.75	17.4	(14)	8 210	17 500	54	70	6	57	8	4	3-M4	6	32	40	62	4.5	0.64	
Σ2020	20	20	3.175	20.75	17.4	(14)	5 290	10 300	54	70	6	63	8	4	3-M4	6	32	40	62	4.5	0.65	
Σ2040	20	40	3.175	20.75	17.4	(14)	3 360	6 170	54	70	6	57	8	4	3-M4	6	32	40	62	4.5	0.64	
Σ2510	25	10	3.175	25.75	22.4	(18)	9 110	21 900	58	74	6	57	8	4	3-M4	6	38	45	66	4.5	1.10	
Σ2520	25	20	3.175	25.75	22.4	(18)	5 870	13 200	58	74	6	63	8	4	3-M4	6	38	45	66	4.5	1.18	
Σ2525	25	25	3.175	25.75	22.4	(18)	5 870	13 200	58	74	6	72	8	4	3-M4	6	38	45	66	4.5	1.30	
Σ2550	25	50	3.175	25.75	22.4	(18)	3 730	7 500	58	74	6	64	8	4	3-M4	6	38	45	66	4.5	1.20	
Σ3220	32	20	3.175	32.75	29.4	(25)	6 540	16 800	70	95	8	70	10	6	3-M5	10	44	53	82	6.6	2.60	
Σ3232	32	32	3.175	32.75	29.4	(25)	6 540	16 800	70	95	8	91	10	6	3-M5	10	44	53	82	6.6	3.15	
Σ4020	40	20	3.969	41.0	36.9	(30)	9 770	26 300	85	110	8	73	10	6	4-M5	10	58	67	96	6.6	5.96	
Σ4040	40	40	3.969	41.0	36.9	(30)	9 770	26 300	85	110	8	107	10	6	4-M5	10	58	67	96	6.6	7.85	
Σ4520	45	20	3.969	46.0	41.9	(35)	10 300	29 700	90	115	8	73	10	6	4-M5	10	63	72	101	6.6	7.73	
Σ4540	45	40	3.969	46.0	41.9	(35)	10 300	29 700	90	115	8	107	10	6	4-M5	10	63	72	101	6.6	10.3	

Mass (kg)	Basic load rating (N)		Basic torque (N·m)		Dimensions															Moment of inertia (kg·cm ²)	Mass (kg)
	Dynamic <i>C_r</i>	Static <i>C_{0r}</i>	Dynamic <i>C_t</i>	Static <i>C_{0t}</i>	<i>D</i>	<i>A</i>	<i>B</i>	<i>L₄</i>	<i>L₅</i>	<i>L₆</i>	<i>L₇</i>	<i>Y</i>	<i>T</i>	<i>M₂</i>	<i>t₂</i>	<i>W₂</i>	<i>D₂</i>	<i>W</i>	<i>X</i>		
	0.50	5 530	7 270	61.5	91.3	48	64	5	60	2.5	6.5	6.5	4.5	6.5	M4	7	25	35	56		
0.55	5 890	8 000	65.5	100	48	64	5	60	2.5	6.5	6.5	4.5	6.5	M4	7	25	35	56	4.5	0.71	0.63
0.74	6 260	8 720	86.3	135	54	70	6	65	2.5	6.5	6.5	5.5	6.5	M5	8	30.5	40	62	4.5	1.15	0.87
0.81	6 610	9 450	91.1	145	54	70	6	65	2.5	6.5	6.5	5.5	6.5	M5	8	30.5	40	62	4.5	1.15	0.87
0.74	6 610	9 450	91.1	145	54	70	6	65	2.5	6.5	6.5	5.5	6.5	M5	8	30.5	40	62	4.5	1.15	0.87
0.81	6 630	9 450	115	185	58	74	6	70	2.5	6.5	6.5	5.5	6.5	M5	8	35.5	45	66	4.5	1.88	1.03
0.88	7 290	10 900	125	210	58	74	6	70	2.5	6.5	6.5	5.5	6.5	M5	8	35.5	45	66	4.5	1.88	1.03
1.00	7 290	10 900	125	210	58	74	6	70	2.5	6.5	6.5	5.5	6.5	M5	8	35.5	45	66	4.5	1.88	1.03
0.91	7 290	10 900	125	210	58	74	6	70	2.5	6.5	6.5	5.5	6.5	M5	8	35.5	45	66	4.5	1.88	1.03
1.46	7 630	11 600	165	285	70	95	8	75	2.5	7.5	6.5	5.5	6.5	M5	8	42	50	82	6.6	3.80	1.62
1.83	7 950	12 400	175	305	70	95	8	75	2.5	7.5	6.5	5.5	6.5	M5	8	42	50	82	6.6	3.80	1.62
2.02	10 600	14 800	290	455	85	110	8	80	4	7.5	8	5.5	8	M5	8	55	65	96	6.6	9.74	2.38
2.85	11 200	15 900	340	490	85	110	8	80	4	7.5	8	5.5	8	M5	8	55	65	96	6.6	9.74	2.38
2.17	11 200	15 900	340	550	90	115	8	85	4	7.5	8	5.5	8	M5	8	60	70	101	6.6	12.5	2.56
3.06	11 700	17 000	360	590	90	115	8	85	4	7.5	8	5.5	8	M5	8	60	70	101	6.6	12.5	2.56

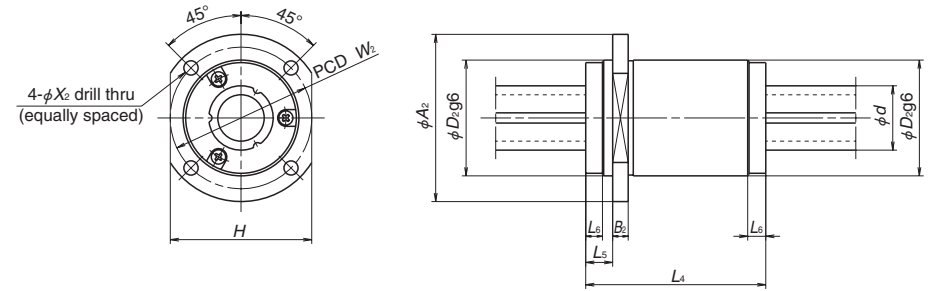
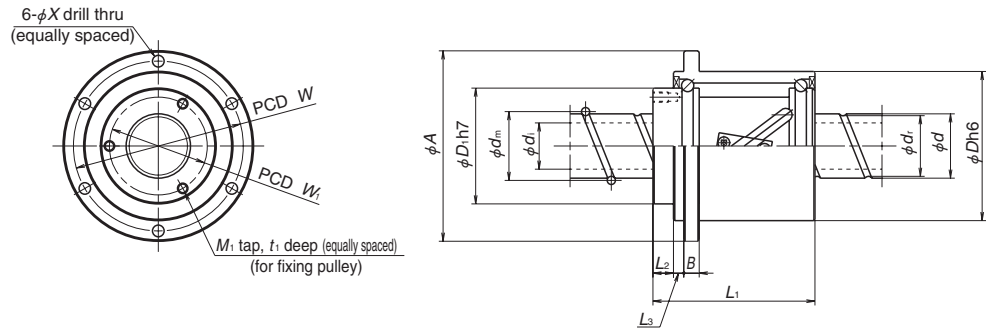

Unit: mm

Model No.	Shaft dia. <i>d</i>	Lead <i>l</i>	Ball dia. <i>D_w</i>	Ball circle dia. <i>d_m</i>	Root dia. <i>d_r</i>	Screw shaft hollow <i>d_i</i>	Ball screw nut													
							Basic load rating (N)		Dimensions											
							Dynamic <i>C_a</i>	Static <i>C_{0a}</i>	<i>D</i>	<i>A</i>	<i>B</i>	<i>L₁</i>	<i>L₂</i>	<i>L₃</i>	<i>M₁</i>	<i>t₁</i>	<i>W₁</i>	<i>D₁</i>	<i>W</i>	<i>X</i>
ΣZ1610	16	10	3.175	16.75	13.4	(8)	4 710	8 110	48	64	5	47	7	4	3-M4	6	28	35	56	4.5
ΣZ1632	16	32	3.175	16.75	13.4	(8)	2 990	4 870				52								
ΣZ2010	20	10					8 210	17 500				57								
ΣZ2020	20	20	3.175	20.75	17.4	(14)	5 290	10 300	54	70	6	63	8	4	3-M4	6	32	40	62	4.5
ΣZ2040	20	40					3 360	6 170				57								
ΣZ2510	25	10					9 110	21 900				57								
ΣZ2520	25	20	3.175	25.75	22.4	(18)	5 870	13 200	58	74	6	63	8	4	3-M4	6	38	45	66	4.5
ΣZ2525	25	25					5 870	13 200				72								
ΣZ2550	25	50					3 730	7 500				64								
ΣZ3220	32	20	3.175	32.75	29.4	(25)	6 540	16 800	70	95	8	70	10	6	3-M5	10	44	53	82	6.6
ΣZ3232	32	32					6 540	16 800				91								
ΣZ4020	40	20	3.969	41.0	36.9	(30)	9 770	26 300	85	110	8	73	10	6	4-M5	10	58	67	96	6.6
ΣZ4040	40	40					9 770	26 300				107								
ΣZ4520	45	20	3.969	46.0	41.9	(35)	10 300	29 700	90	115	8	73	10	6	4-M5	10	63	72	101	6.6
ΣZ4540	45	40					10 300	29 700				107								

Moment of inertia (kg·cm ²)	Mass (kg)	Ball spline nut																	Mass (kg)
		Basic load rating (N)		Basic torque (N·m)		Dimensions													
		Dynamic <i>C_t</i>	Static <i>C_{0t}</i>	Dynamic <i>C_t</i>	Static <i>C_{0t}</i>	<i>D₂</i>	<i>A₂</i>	<i>B₂</i>	<i>L₄</i>	<i>L₅</i>	<i>L₆</i>	<i>H</i>	<i>W₂</i>	<i>X</i>					
0.41	0.50	5 530	7 270	61.5	91.3	35	55	6	60	10.5	6.5	45	4.5	4.5	0.35				
0.44	0.55	5 890	8 000	65.5	100														
0.64	0.74	6 260	8 720	86.5	135														
0.65	0.81	6 610	9 450	91.1	145	40	60	6	65	10.5	6.5	50	50	5.5	0.46				
0.64	0.74	6 610	9 450	91.1	145														
1.10	0.81	6 630	9 450	115	185														
1.18	0.88	7 290	10 900	125	210														
1.30	1.00	7 290	10 900	125	210	45	65	6	70	10.5	6.5	55	55	5.5	0.57				
1.20	0.91	7 290	10 900	125	210														
2.60	1.46	7 630	11 600	165	285														
3.15	1.83	7 950	12 400	175	305	50	70	6	75	10.5	6.5	60	60	5.5	0.64				
5.96	2.02	10 600	14 800	290	455														
7.85	2.85	11 200	15 900	305	490	65	88	8	80	12	8	76	76	6.6	1.20				
7.73	2.17	11 200	15 900	340	550														
10.3	3.06	11 700	17 000	360	590	70	93	8	85	12	8	81	81	6.6	1.39				

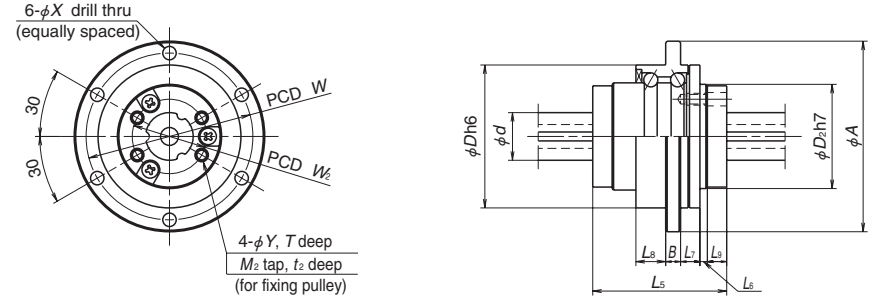
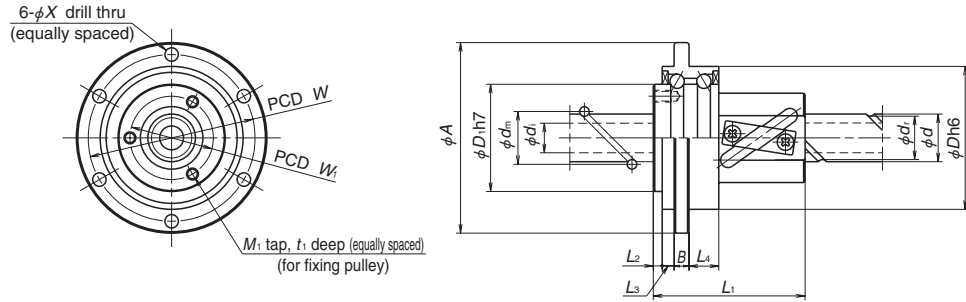

Unit: mm

Model No.	Shaft dia. <i>d</i>	Lead <i>l</i>	Ball dia. <i>D_w</i>	Ball circle dia. <i>d_m</i>	Root dia. <i>d_r</i>	Screw shaft hollow <i>d_i</i>	Ball screw nut																	Moment of inertia (kg·cm ²)
							Basic load rating(N)		Dimensions															
							Dynamic <i>C_a</i>	Static <i>C_{0a}</i>	<i>D</i>	<i>A</i>	<i>B</i>	<i>L₁</i>	<i>L₂</i>	<i>L₃</i>	<i>L₄</i>	<i>M₁</i>	<i>t₁</i>	<i>W₁</i>	<i>D₁</i>	<i>W</i>	<i>X</i>			
ΣC1610	16	10	3.175	16.75	13.4	(8)	4 710	8 110	48	64	5	46	3	4	10	3-M4	6	28	35	56	4.5	0.40		
ΣC1632		32					2 990	4 870				51										0.43		
ΣC2010	20	10	3.175	20.75	17.4	(14)	8 210	17 500	54	70	6	56	4	4	10	3-M4	6	32	40	62	4.5	0.63		
ΣC2020		20					5 290	10 300				63										0.65		
ΣC2040		40					3 360	6 170				56										0.63		
ΣC2510	25	10	3.175	25.75	22.4	(18)	9 110	21 900	58	74	6	56	4	4	10	3-M4	6	38	45	66	4.5	1.04		
ΣC2520		20					5 870	13 200				63										1.13		
ΣC2525		25					5 870	13 200				71										1.24		
ΣC2550		50					3 730	7 500				63										1.13		

Mass (kg)	Basic load rating(N)		Basic torque(N·m)		Ball spline nut																	Moment of inertia (kg·cm ²)	Mass (kg)
	Dynamic <i>C_r</i>	Static <i>C_{0r}</i>	Dynamic <i>C_t</i>	Static <i>C_{0t}</i>	Dimensions																		
	<i>D</i>	<i>A</i>	<i>B</i>	<i>L₅</i>	<i>L₆</i>	<i>L₇</i>	<i>L₈</i>	<i>L₉</i>	<i>Y</i>	<i>T</i>	<i>M₂</i>	<i>t₃</i>	<i>W₂</i>	<i>D₂</i>	<i>W</i>	<i>X</i>							
0.41	4 300	5 090	47.9	63.9	48	64	5	45	2.5	6.5	10	6.5	4.5	6.5	M4	7	25	35	56	4.5	0.52	0.42	
0.43																							
0.53	4 730	5 820	65.1	90.5	54	70	6	50	2.5	6.5	10	6.5	5.5	6.5	M5	8	30.5	40	62	4.5	0.86	0.56	
0.56	5 110	6 540	70.5	100																			
0.53	5 110	6 540	70.5	100	58	74	6	55	2.5	6.5	10	6.5	5.5	6.5	M5	8	35.5	45	66	4.5	1.44	0.67	
0.60	5 130	6 540	87.8	125																			
0.64	5 870	8 000	100	155																			
0.69	5 870	8 000	100	155																			
0.64	5 870	8 000	100	155	58	74	6	55	2.5	6.5	10	6.5	5.5	6.5	M5	8	35.5	45	66	4.5	1.44	0.67	
0.64	5 870	8 000	100	155																			

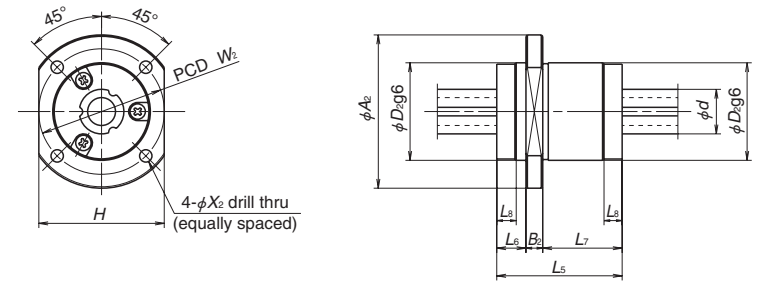
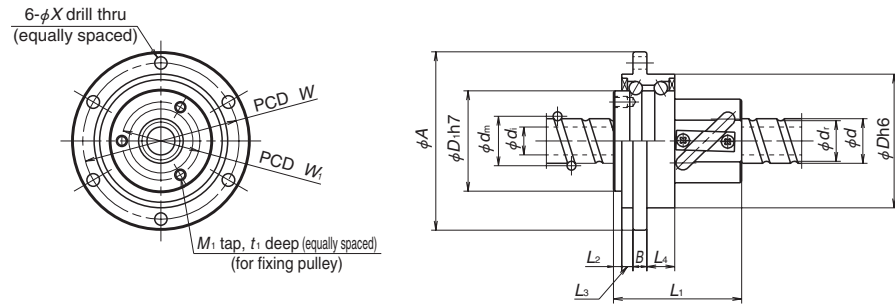

Model No.	Shaft dia. <i>d</i>	Lead <i>l</i>	Ball dia. <i>D_w</i>	Ball circle dia. <i>d_m</i>	Root dia. <i>d_r</i>	Screw shaft hollow <i>d_i</i>	Ball screw nut																
							Basic load rating(N)		Dimensions														
							Dynamic <i>C_s</i>	Static <i>C_{0s}</i>	<i>D</i>	<i>A</i>	<i>B</i>	<i>L₁</i>	<i>L₂</i>	<i>L₃</i>	<i>L₄</i>	<i>M₁</i>	<i>t₁</i>	<i>W₁</i>	<i>D₁</i>	<i>W</i>	<i>X</i>		
ΣCZ1610	16	10	3.175	16.75	13.4	(8)	4 710	8 110	48	64	5	46	3	4	10	3-M4	6	28	35	56	4.5		
ΣCZ1632		32					2 990	4 870	51	56													
ΣCZ2010	20	10	3.175	20.75	17.4	(14)	8 210	17 500	54	70	6	63	4	4	10	3-M4	6	32	40	62	4.5		
ΣCZ2020		20					5 290	10 300														63	56
ΣCZ2040		40					3 360	6 170														56	
ΣCZ2510	25	10	3.175	25.75	22.4	(18)	9 110	21 900	58	74	6	63	4	4	10	3-M4	6	38	45	66	4.5		
ΣCZ2520		20					5 870	13 200														71	63
ΣCZ2525		25					5 870	13 200														71	63
ΣCZ2550		50					3 730	7 500														63	

Unit: mm

Moment of inertia (kg·cm ²)	Mass (kg)	Ball spline nut																	Mass (kg)
		Basic load rating(N)		Basic torque(N·m)		Dimensions													
		Dynamic <i>C_r</i>	Static <i>C_{0r}</i>	Dynamic <i>C_t</i>	Static <i>C_{0t}</i>	<i>D₂</i>	<i>A₂</i>	<i>B₂</i>	<i>L₅</i>	<i>L₆</i>	<i>L₇</i>	<i>L₈</i>	<i>H</i>	<i>W₂</i>	<i>X₂</i>				
0.40	0.41	4 300	5 090	47.9	63.9	35	55	6	45	10.5	28.5	6.5	45	45	4.5	0.26			
0.43	0.43																		
0.63	0.53	4 730	5 820	65.1	90.5	40	60	6	50	10.5	33.5	6.5	50	50	5.5	0.35			
0.65	0.56	5 110	6 540	70.5	100														
0.63	0.53	5 110	6 540	70.5	100	45	65	6	55	10.5	38.5	6.5	55	55	5.5	0.44			
1.04	0.60	5 130	6 540	87.8	125														
1.13	0.64	5 870	8 000	100	155														
1.24	0.69	5 870	8 000	100	155														
1.13	0.64	5 870	8 000	100	155														

B-3-3.11 Ball Screw with L1 Seal designed for Minimal Grease Splatter [Patent application submitted]

1. Features

● Substantial reduction in grease splatter
The amount of grease splatter for the L1 seal is reduced to 1/10 compared to NSK standard seal to contribute to maintain equipment and working environment clean.

● Adoption of non-contact type seal
Seal torque is avoided by optimizing the seal shape. The current seals with relatively small splatter are all contact type seals, but the L1 seal is the first non-contact type seal to achieve low grease splatter.

● Seal cover is equipped as standard.
To prevent grease from dripping, a seal cover is equipped as standard.

● Later fitting to NSK standard ball screws is available.

NSK ensures quick delivery because later fitting to "Compact FA Series" and "High Speed SS Series" is possible.

2. Specifications

(1) Applicable ball screw

- Shaft diameter : 15 to 23 mm
- Lead : 5 mm min.
- Lubricant : NSK standard grease, NSK clean grease, grease for general food
- Environment : Ambient temperature
- Short lead time: Can be fitted to NSK standard stock ball screws.
Compact FA series (dia.15 to 25 mm)
High speed SS series (dia.32 mm)

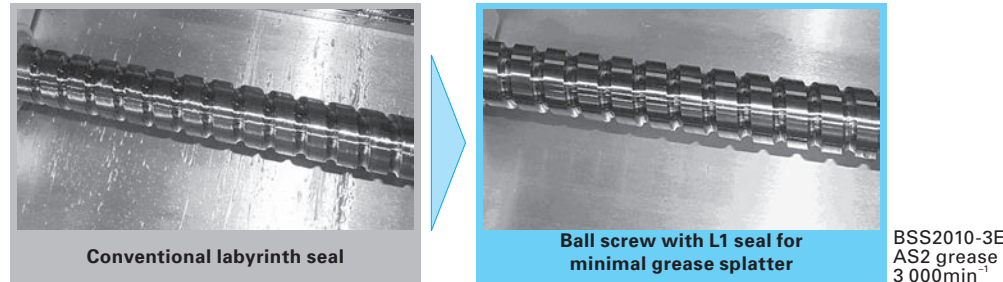

Fig. 1 Comparison of grease splatter from the shaft

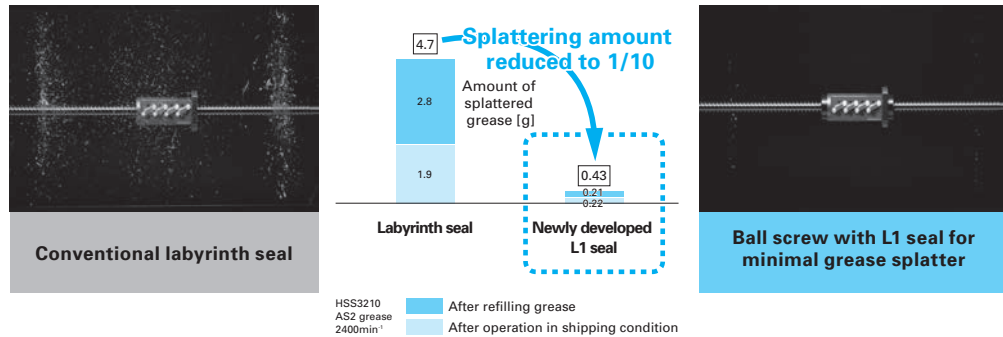

Fig. 2 Results of grease splattering test

(2) Design-related precautions

When designing the screw shaft end, the one end shall be cut-through. For general precautions regarding ball screws, refer to "Design Precautions" (page B83) and "Handling Precautions" (page B103).

Table 1 Combinations of shaft diameter and lead

Lead \ Shaft dia.	5	10	20	25	Applicable series
15	○	○	○		Compact FA
20	○	○	○		
25	○	○	○	○	High speed SS
32	○	○			

Please contact NSK except for the above types.

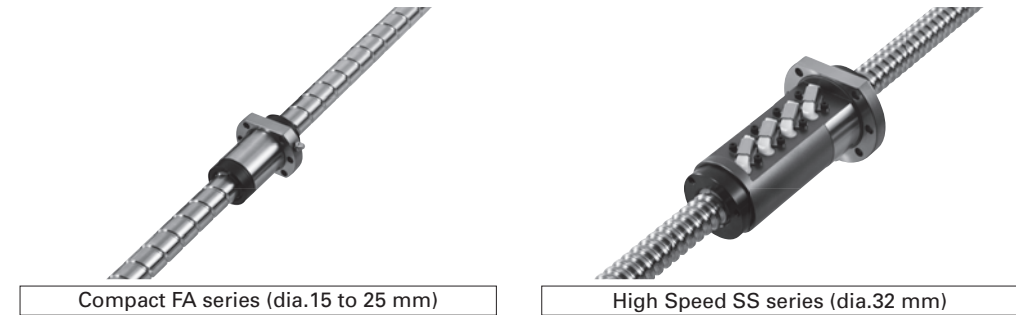

Fig. 3 Appearance

3. Example of reference number

A structure of "Reference number for ball screw" is as follows.
*"L1" is added at the end of "nut model code" and "Specifications number".

◇Reference number for ball screw

W2005 -*L1 - C5Z10**
NSK L1 equipped type ball screw code

4. Precautions for use

- Maximum temperatures are as follows.
Compact FA series with L1 seal: 80 °C (at outside diameter of ball nut)
High Speed SS series with L1 seal: 60 °C (at outside diameter of ball nut)
- Do not use the product in environments where foreign matter is present.
- Please note that L1 seal reduces grease splatter but cannot reduce it to zero.

The data shown in the catalog are the results of our tests, and no warranty is given to sealing performance on actual usage on machinery.
The amount of grease splatter is affected by usage conditions (rotational speed, temperature, greases, grease filling amount). Dust covers and other measures to keep machinery free of dust are recommended.

Ball Screw with L1 Seal designed for Minimal Grease Splatter

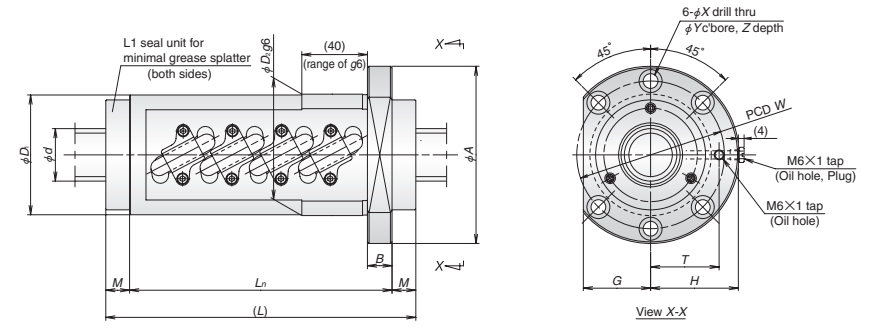
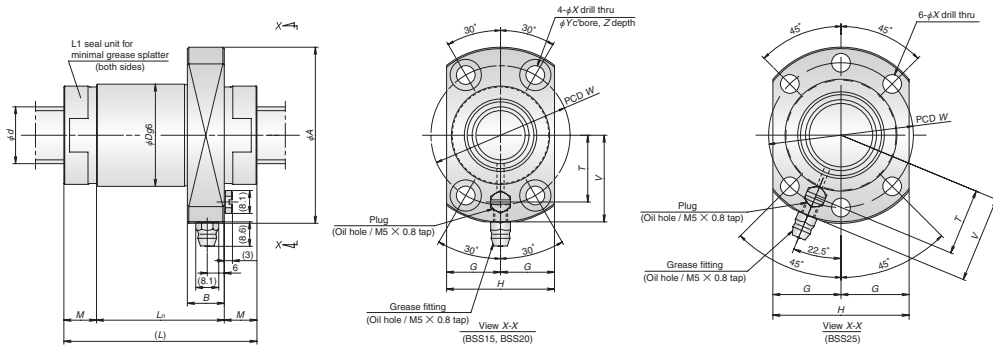

Model No.	Shaft dia. <i>d</i>	Lead <i>l</i>	Basic load rating (N)		Ball nut dimensions										Seal dimensions <i>M</i>	Total length with nut & seal <i>L</i>	Internal spatial volume of nut (cm ³)	Standard volume of grease replenishing (cm ³)			
			Dynamic <i>C_a</i>	Static <i>C_{0a}</i>	Dia. <i>D</i>	Flange <i>A</i> <i>G</i> <i>H</i> <i>B</i>	Nut length <i>L_n</i>	Bolt holes <i>W</i> <i>X</i> <i>Y</i> <i>Z</i>	Oil hole position <i>T</i> <i>V</i>												
BSS1505-3E	15	5	5 460	10 200	28	51	15.5	31	11	30	39	5.5	9.5	5.5	18	25	10	50	2.0	1.0	
BSS1510-3E		10																			
BSS1520-2E	15	20	5 070	8 730	32	55	16.5	33		51	43				20	27	15	81	2.8	1.4	
BSS2005-3E	20	5	8 790	18 500	36	62	19	38	13	31	49	6.6	11	6.5	23.5	30.5	12	55	3.4	1.7	
BSS2010-3E		10																			
BSS2020-2E	20	20	5 900	11 700						54							18	90	3.2	1.6	
BSS2505-3E	25	5	9 760	23 600	40	62	24	48	12	32	51	6.6	-	-	23.5	30.5	12	56	4.4	2.2	
BSS2510-4E		10																			
BSS2520-2E		20																			
BSS2525-2E	25	25	6 560	14 600						63							20	94	3.9	2.0	
																			103	4.3	2.2

Model No.	Shaft dia. <i>d</i>	Lead <i>l</i>	Basic load rating (N)		Ball nut dimensions										Seal dimensions <i>M</i>	Total length with nut & seal <i>L</i>	Internal spatial volume of nut (cm ³)	Standard volume of grease replenishing (cm ³)		
			Dynamic <i>C_a</i>	Static <i>C_{0a}</i>	Dia. <i>D₁</i> <i>D₂</i>	Flange <i>A</i> <i>G</i> <i>H</i> <i>B</i>	Nut length <i>L_n</i>	Bolt holes <i>W</i> <i>X</i> <i>Y</i> <i>Z</i>	Oil hole position <i>T</i>											
HSS3205	32	5	18 500	56 100	57	58	85	32	42	13	89	71	6.6	11	6.5	33	9.5	108	10	5
HSS3210	32	10	46 300	108 000	73	74	108	41	53.5	15	160	90	9	14	8.5	45	14.5	189	43	22

- Notes: 1. Maximum operating temperature: 80°C (at outside diameter of ball nut)
 2. Grease nipple attachment is done only on the outer side of the flange (see diagram).

Notes: 1. Maximum operating temperature: 60°C (at outside diameter of ball nut)

B-3-3.12 Equipped with "NSK K1™" Lubrication Unit

This product is being applied for a patent.

1. Features

NSK K1 is a new, efficient lubrication unit. Equipped with NSK K1, the ball screws demonstrate a superb performance as shown below.

- Long-term, maintenance-free usage

In mechanical environments where lubrication is difficult to apply, long-term running efficiency is maintained by using the NSK K1 in combination with grease.

[ex.] For automotive component processing lines, etc.

- Does not pollute the environment

A very small volume of grease combined with NSK K1 can provide sufficient lubrication in the environment where grease is undesirable as well as in the environment where high cleanliness is required.

[ex.] Food processing equipment, medical equipment, liquid crystal display/semiconductor manufacturing equipment, etc.

- Good for environments where lubricant is washed away

When used with grease, life of the machine is prolonged even when the machine is washed entirely by water, or in an environment where the machine is exposed to rain or wind.

[ex.] Food processing equipment, housing/construction machines, etc.

- Maintains efficiency in dusty environment

In environment where oil- and grease-absorbing dust is produced, long-term efficiency in lubrication and prevention from foreign inclusions are maintained by using the NSK K1 in combination with grease.

[ex.] Woodworking machines, etc.

- Comparative duration test of samples with and without NSK K1

Sample, testing conditions and test result are shown in **Table 1** and **Fig. 1**.

Without lubricant, operation became impossible after running 8.6 km. With NSK K1 alone, it was possible to continue running exceeding 10 000 km.

NSK conducts various tests under different conditions. Please consult NSK.

Table 1 Sample and testing conditions

Ball screw	Shaft dia. 20 mm, lead 20 mm
Lubrication	Comparison with only NSK K1 against no lubrication
Speed	4 000 min ⁻¹ (80 m/min)
Stroke	600 mm

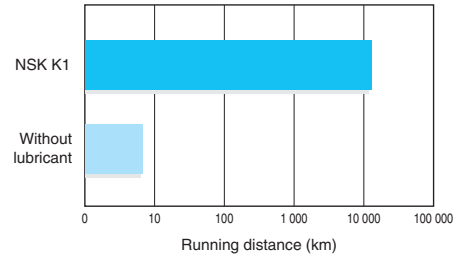

Fig. 1 Duration test results on ball screws without lubricant

2. Specifications

(1) Structure

The structure makes it possible to have a stable contact between the NSK K1 and outside of a ball screw with moderate force by a garter spring which fits onto outside of the NSK K1.

NSK K1 is installed between the ball screw nut and the labyrinth seal. The overall nut length is slightly longer than that of the standard ball screw.

Combination of NSK standard grease (factory-packed in the nut) and NSK K1 are standard specifications.



Fig. 2 NSK K1

(2) Accuracy grade and axial play

Accuracy grades, clearance and preload specifications remain unchanged from the existing products. There is a slight increase in torque due to the equipped NSK K1.

(3) Overall nut length after equipped with NSK K1™

The nut length becomes longer than that of standard ball screws after equipped with NSK K1. The nut length after equipped with K1 is shown in pages B579 to B582 for each type of ball recirculation. NSK K1 can be installed on other types not listed in the dimension table. Please consult with NSK if you require the K1 for a special ball nut.

(4) Application examples

Ball screws equipped with NSK K1 are maintenance-free for a long period of time. Its application is expanding in various industries.

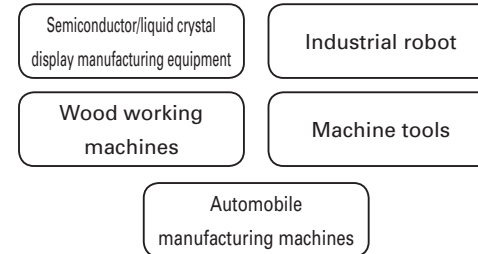

◇Reference number for ball screw equipped with NSK K1

W1401 - P K1 - C3 Z10**

NSK K1 equipped type ball screw code

3. Precautions for use

Temperature range for use: Maximum temperature: 50°C
Momentary maximum temperature: 80°C

Chemicals that should not come to contact with K1:

Do not leave NSK K1 in organic solvent, white kerosene such as hexane, thinner which removes oil, and rust preventive oil which contains white kerosene.

Note: Water-type cutting oil, oil-type cutting oil, grease such as mineral-type AS2 and ester-type PS2 do not damage K1 Seal.

Note: NSK K1 is not applicable to the Compact FA series.

4. Example of reference number

A structure of "Reference number for ball screw" is as follows.

Note: "K1" is added at the end of "nut model code" and "Specifications number".

(1) Tube type

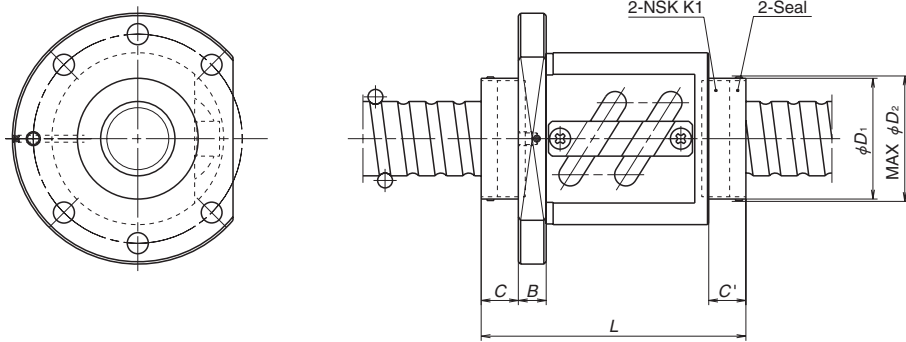

Tube type

Model No.	Screw shaft dia. <i>d</i>	Lead <i>l</i>	K1 installing dimension		Frange width <i>B</i>	Overall length when equipped K1 <i>L</i>	K1 cap dimension	
			<i>C</i>	<i>C'</i>			Cap dia. ϕD_1	Protruding dimension ϕD_2
PFT1004-2.5	10	4	14	15	10	61.5	$\phi 22$	MAX $\phi 24$
PFT1205-2.5	12	5	14	15	10	66	$\phi 26.5$	MAX $\phi 29$
LPFT1210-2.5		10		17		79		
PFT1405-2.5	14	5	14	15	10	65	$\phi 30$	MAX $\phi 32$
LPFT1510-2.5	15	10	14	15	10	76	$\phi 30$	MAX $\phi 32$
PFT1605-2.5	16	5	14	15	10	67	$\phi 32$	MAX $\phi 34$
PFT2005-5	20	5	14	14	10	81	$\phi 38$	MAX $\phi 40$
LPFT2010-2.5		10				78		
LPFT2020-1.5		20				84		
ZFT2505-10	25	5	16	17	10	115	$\phi 44$	MAX $\phi 46$
PFT2506-5		6	16	17	12	93	$\phi 44$	MAX $\phi 46$
PFT2510-2.5		10	16	17	12	89	$\phi 44$	MAX $\phi 46$
ZFT2510-3						103		
LPFT2520-2.5		20	12	12	12	109	$\phi 38$	MAX $\phi 40$
LPFT2525-1.5		25	12	12	12	98	$\phi 38$	MAX $\phi 40$
DFT2805-5		28	5	16	17	12	137	$\phi 48$
PFT2810-2.5	10		90					
DFT2810-3						174		
PFT3206-5	32	6	16	17	12	93	$\phi 52$	MAX $\phi 54$
ZFT3206-10						129		
PFT3210-5		10	16	17	17	122	$\phi 52$	MAX $\phi 54$
ZFT3210-5						122		
DFT3210-5		16	16	212				
PFT3212-3		12	16	17	16	114	$\phi 52$	MAX $\phi 54$
DFT3212-3						198		
LPFT3225-2.5		25	12	12		122	$\phi 46$	MAX $\phi 48$
LPFT3232-1.5		32	12	12		109	$\phi 46$	MAX $\phi 48$

Notes: 1. NSK K1 can be installed in other types not listed in the table. Please consult NSK.
2. C, C' and L are the dimensions when one NSK K1 is equipped to both ends of the nut.

Model No.	Screw shaft dia. <i>d</i>	Lead <i>l</i>	K1 installing dimension		Frange width <i>B</i>	Overall length when equipped K1 <i>L</i>	K1 cap dimension						
			<i>C</i>	<i>C'</i>			Cap dia. ϕD_1	Protruding dimension ϕD_2					
PFT3610-5	36	10	19	20	15	131	$\phi 56$	MAX $\phi 58$					
DFT3610-5				19		221							
HZF3616-5				19		163							
HZF3620-3.5		20		19		146							
PFT4008-5	40	8	19	20	16	117	$\phi 62$	MAX $\phi 64$					
ZFT4008-10						165							
ZFT4010-7		10	19	20	16	152	$\phi 62$	MAX $\phi 64$					
DFT4010-5				19		222							
PFT4012-5		12	19	19	20	16	144	$\phi 62$	MAX $\phi 64$				
DFT4012-5					19		252						
HZF4016-5					16		19			19	164	$\phi 61$	MAX $\phi 64$
HZF4020-5					20		19			19	189	$\phi 61$	MAX $\phi 64$
LPFT4032-2.5					32		14			14	151	$\phi 54$	MAX $\phi 56$
LPFT4040-1.5					40		14			14	133	$\phi 54$	MAX $\phi 56$
DFT4510-5	45	10	19	19	16	222	$\phi 72$	MAX $\phi 75$					
DFT4512-5		12		19	16	254							
HZF4520-5		20		18	190								
ZFT5010-10	50	10	19	20	18	194	$\phi 73$	MAX $\phi 76$					
DFT5012-5		12		19		256							
ZFT5016-5		16		20		172							
DFT5016-5				19		300							
HZF5020-5		20		19		192							
HZF5025-5		25		19		221							
DFT5516-5	55	16	22	22	18	178	$\phi 81$	MAX $\phi 87$					
HZF5520-5		20		198	MAX $\phi 81$								
HZF5525-5		25		227	MAX $\phi 81$								
DFT6316-5	63	16	22	22	18	322	$\phi 89$	MAX $\phi 95$					
DFT6320-5		20		362									

(2) Deflector(bridge) type

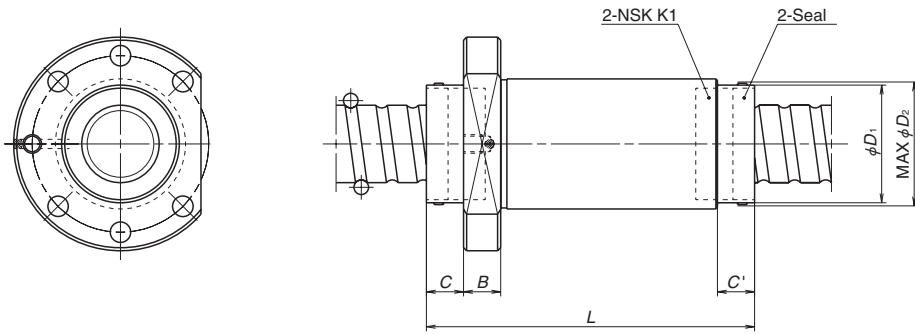

Deflector(bridge) type

(3) End cap type

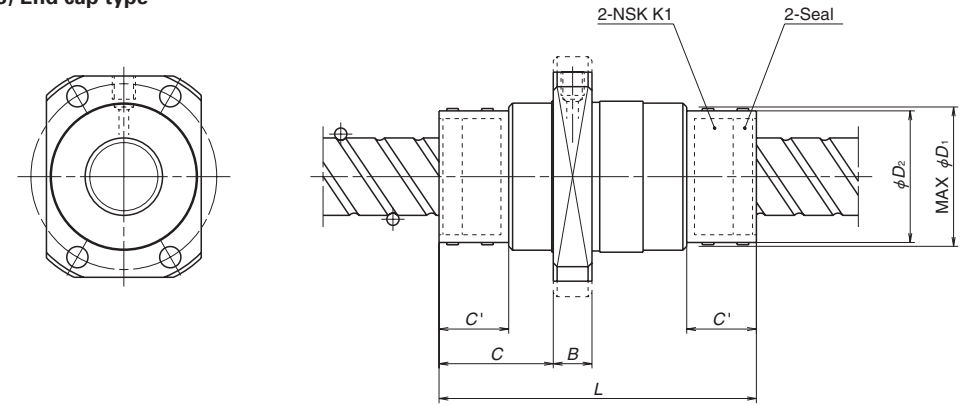

End cap type

Model No.	Screw shaft dia. <i>d</i>	Lead <i>l</i>	K1 installing dimension		Frange width <i>B</i>	Overall length when equipped K1 <i>L</i>	K1 cap dimension	
			<i>C</i>	<i>C'</i>			Cap dia. ϕD_1	Protruding dimension ϕD_2
ZFD2005-6	20	5	9	9	12	87	$\phi 32$	MAX $\phi 34$
ZFD2506-6	25	6	12	—	12	102	$\phi 38$	MAX $\phi 40$
ZFD2510-4		10		12		106		
ZFD3208-8	32	8	12	12	12	136	$\phi 46$	MAX $\phi 48$
ZFD3210-6		10				138		
ZFD3212-6		12				153		
ZFD4010-8	40	10	14	14	16	167	$\phi 54$	MAX $\phi 57$
ZFD4012-8		12				189		
ZFD5010-8	50	10	14	14	18	169	$\phi 64$	MAX $\phi 67$
ZFD5012-6		12				167		

Notes: 1. NSK K1 can be installed in other types not listed in the table. Please consult NSK.
2. C, C' and L are the dimensions when one NSK K1 is equipped to both ends of the nut.

Model No.	Screw shaft dia. <i>d</i>	Lead <i>l</i>	K1 installing dimension		Frange width <i>B</i>	Overall length when equipped K1 <i>L</i>	K1 cap dimension	
			<i>C</i>	<i>C'</i>			Cap dia. ϕD_1	Protruding dimension ϕD_2
UPFC1520-1.5	15	20	29	18	10	81	$\phi 30$	MAX $\phi 32$
LPFC1616-3	16	16	28	18	10	74	$\phi 28$	MAX $\phi 30$
LPFC2020-3	20	20	29.5	18	10	82	$\phi 34$	MAX $\phi 36$
UPFC2040-1		40	29			77		
LPFC2525-3	25	25	34	21	12	97	$\phi 44$	MAX $\phi 46$
UPFC2550-1		50				92		
LPFC3232-3	32	32	37	21	12	112	$\phi 52$	MAX $\phi 54$
UPFC3264-1		64				36.5		
LPFC4040-3	40	40	43.5	24	15	133	$\phi 62$	MAX $\phi 65$
LPFC5050-3	50	50	45.5	24	20	155	$\phi 74$	MAX $\phi 77$

Notes: 1. NSK K1 can be installed in other types not listed in the table. Please consult NSK.
2. C, C' and L are the dimensions when one NSK K1 is equipped to both ends of the nut.

B-3-3.13 Special Ball Screws

In addition to the standard ball screws, NSK manufactures various types of ball screws in special shapes as shown below.

Thoroughly discuss with NSK the specifications before determining specifications and ordering ball screws in special shapes.

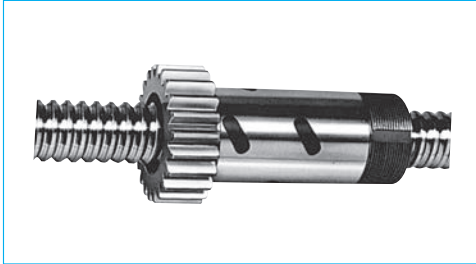

Nut with gear

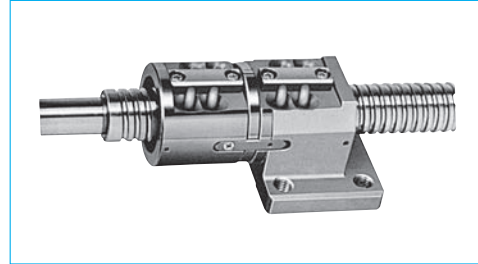

Double nut with flat mounting surface

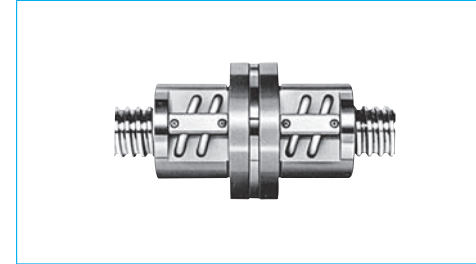

Flanged to flanged ball nut

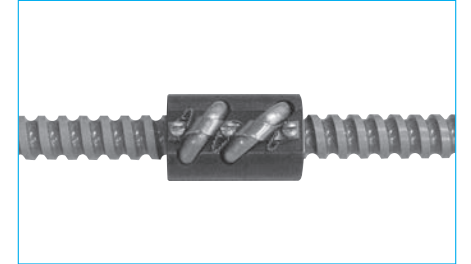

Ball screw for aircraft

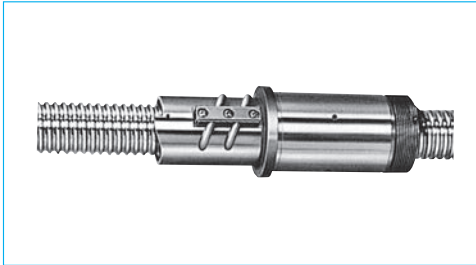

Lightly preloaded single nut with bearing seat

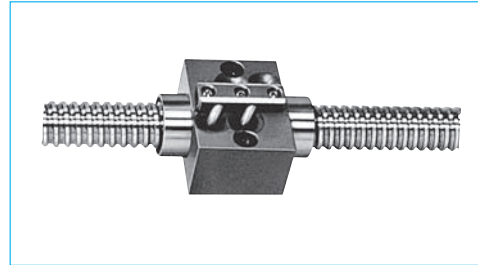

Lightly preloaded single nut with flat mounting surface

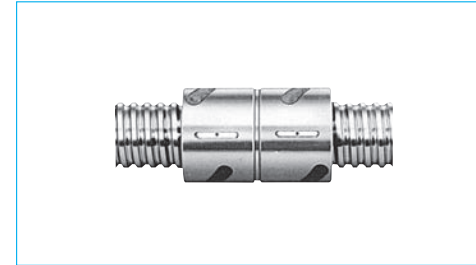

Cylindrical double nut

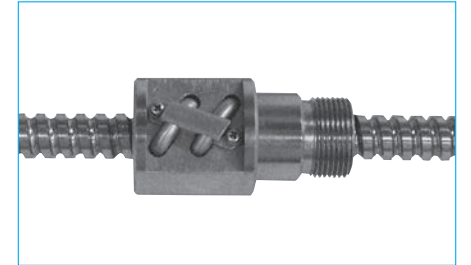

Ball screw for nuclear power plant

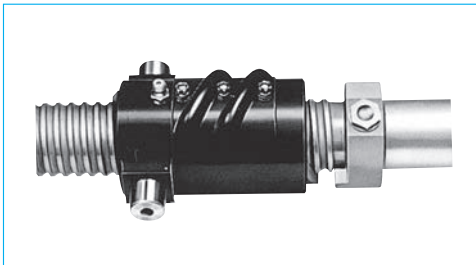

Nut with trunion

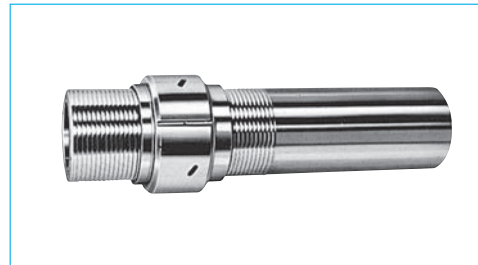

Hollow shaft, lightly preloaded single nut, with large shaft diameter and fine lead

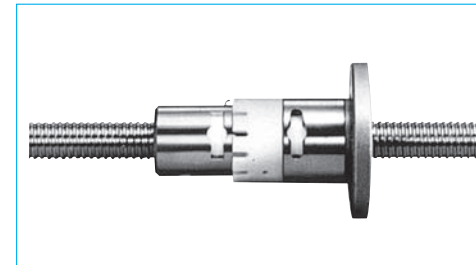

Spring preloaded ball screw

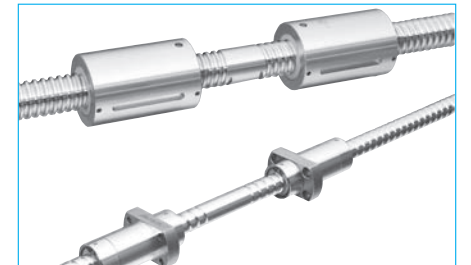

Right and left hand thread on each side of screw

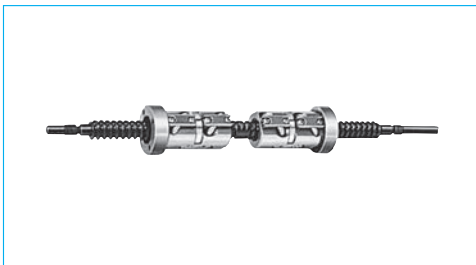

Double nut with right and left turn thread on each side of screw shaft

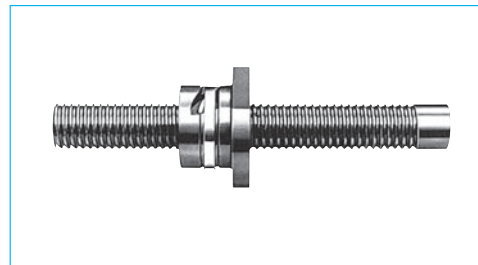

Ceramic ball screw

C-1 Monocarrier™

1. Features	C5
2. Classification and Series	C7
3. Accessories	C9
4. Selection of Monocarrier	C10
4.1. Procedures for Selecting Monocarrier..	C10
4.2. Rigidity	C10
4.3. Maximum Speed	C11
4.4. Accuracy Grade	C13
4.5. Stroke and Ball Screw Lead ..	C13
4.6. Basic Load Rating	C15
4.7. Estimation of Life Expectancy..	C17
4.8. Example of Life Estimation ..	C19
5. MCM Series	C23
5.1. MCM Series Reference Number Coding ..	C25
5.2. MCM Series Dimension Table of Standard Products	C26
5.3. MCM Series Accessories ..	C47
6. MCH Series.....	C71
6.1 MCH Series Reference Number Coding ...	C73
6.2 MCH Series Dimension Table of Standard Products.....	C74
6.3 MCH Series Accessories.....	C81

C-2 Toughcarrier™

1. Features	C93
2. Classification and Series	C93
3. Accessories	C95
4. Selection of Toughcarrier	C96
4.1 Selection Procedures	C96
4.2 Stroke and Lead	C97
4.3 Reference Number Coding and Accuracy Grade.....	C98
4.4 Maximum Speed.....	C99
4.5 Rigidity	C101
4.6 Basic Load Rating	C102
4.7 Estimation of Life Expectancy..	C103
4.8 Example of Life Estimation..	C105
5. TCH Series Dimension Table for Standard Products.....	C109
5.1 TCH06 Series	C109
5.2 TCH09 Series	C111
5.3 TCH10 Series	C113
6. Accessories	C115
6.1 Sensor Unit	C115
6.2 Cover Unit.....	C116
6.3 Motor Bracket	C119
7. Motor Bracket Compatibility Table..	C128
8. Sensor Rail and Top Cover Unit Combination Table	C129
9. Toughcarrier High-Thrust Series ..	C132

C-3 Technical Materials

1. Sensor Specification	C135
1.1 Proximity Switch	C135
1.2 Photo Sensor	C136
2. Characteristics and Evaluation Method	C137
2.1 Positioning Accuracy	C137
2.2 Repeatability.....	C137
2.3 Running Parallelism.....	C137
3. Special Specifications	C138
4. Maintenance.....	C139
4.1 Maintenance Method	C139
4.2 NSK K1™ Lubricant Unit....	C139
5. NSK Clean Grease LG2 Specification ..	C140

C BLOCK

Monocarrier™

Toughcarrier™

C3-C90

C91
-C132

C133
-C140

Monocarrier™, Toughcarrier™

All-in-one structure (ball screw, linear guide and base integrated) results in a light and compact actuator without extra work for design or adjustment when installing. Design and assembly loads can be reduced by unit type. Also, the many variations make it possible to deal with many different uses.

Monocarrier™ and Toughcarrier™ Classifications

● Monocarrier™

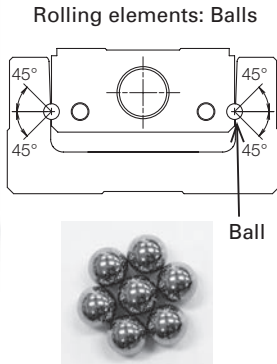
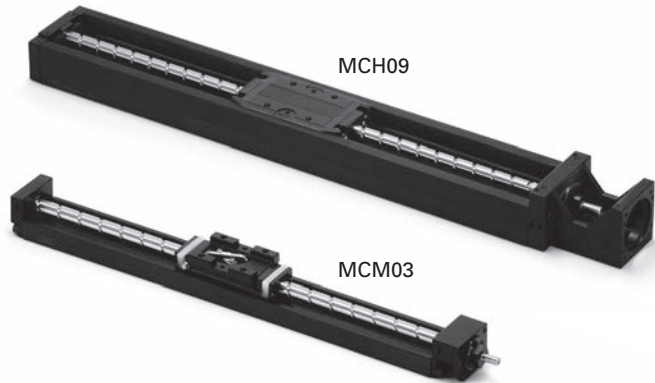

● Toughcarrier™: High load capacity

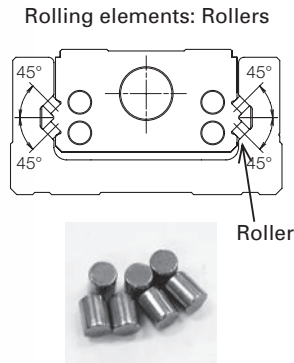
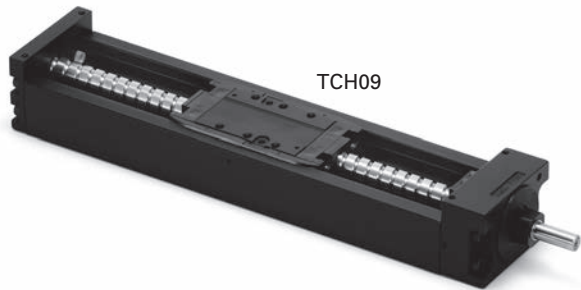

Procedure for Selecting Monocarrier™ and Toughcarrier™ models

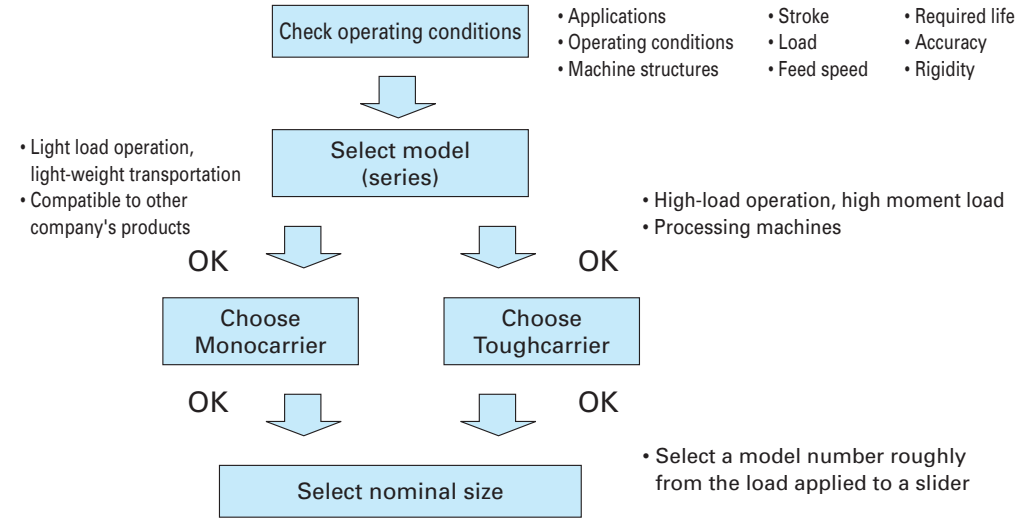

Monocarrier™ and Toughcarrier™ Composition

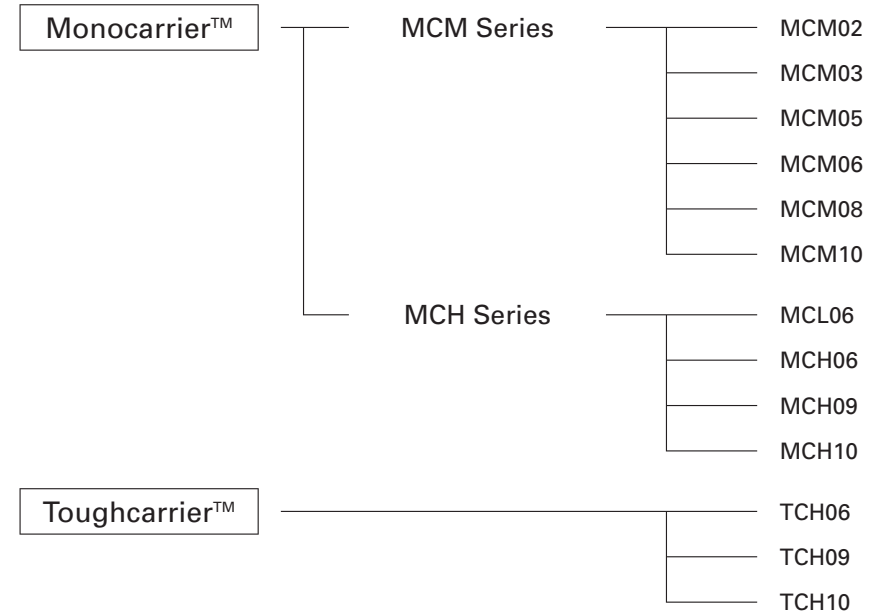

C-1 Monocarrier™

1 Features	C5
2 Classification and Series	C7
3 Accessories	C9
4 Selection of Monocarrier	C10
4.1 Procedures for Selecting Monocarrier	C10
4.2 Rigidity	C10
4.3 Maximum Speed	C11
4.4 Accuracy Grade	C13
4.5 Stroke and Ball Screw Lead	C13
4.6 Basic Load Rating	C15
4.7 Estimation of Life Expectancy	C17
4.8 Example of Life Estimation	C19
5 MCM Series	C23
5.1 MCM Series Reference Number Coding	C25
5.2 MCM Series Dimension Table of Standard Products	C26
5.3 MCM Series Accessories	C47
6 MCH Series	C71
6.1 MCH Series Reference Number Coding	C73
6.2 MCH Series Dimension Table of Standard Products	C74
6.3 MCH Series Accessories	C81

C-1 Monocarrier™

C-1 Monocarrier™

C-1-1 Features

NSK's Monocarrier is the culmination of technology and innovation in linear motion. This lightweight, compact single axis linear actuator integrates quality NSK ball screw, linear guide and support bearings into one unit.

1 Light weight, compact design

- Available in two different shapes of cross-section, depending on application.
Light weight type: MCM Series
Rigid type: MCH Series

2 All-in-one structure

- The all-in-one structure integrates a ball screw, a linear guide and support bearings into a single unit to significantly reduce design and installation time.
- Multiple datum planes, the bottom and a lateral side of the rail, facilitate highly accurate installation.
- Immediate operation after installation and run-in is possible.
- A wide selection of fine to high helix leads are available.

4 Long term maintenance free

- Use of NSK K1 Lubrication Units and grease maintains a smooth lubricating performance for long periods in mechanical environments where lubrication is difficult to apply, where use of oil is not permitted because of hygienic issues, or where the mechanical equipment is subjected to frequent wash downs.
- NSK K1 lubrication unit is available for food processing machines and medical equipment.
- Grease for clean environments and for general machinery is available.

3 Superb antirust capability

- Low temperature chrome plating is a standard feature for the bodies and sliders to control rusting in normal operating and storing environments. Fluoride low temperature chrome plating is optionally available for much higher rust prevention.



5 Quick Delivery

MONOCARRIER™

C-1-2 Classification and Series

Table 2.1

	Light Weight	Beam Rigidity	Moment Rigidity
MCM Series	⊙	○	○
MCH Series	○	⊙	○

⊙: Excellent ○: Suitable in use

[MCM Series Cross-sections]

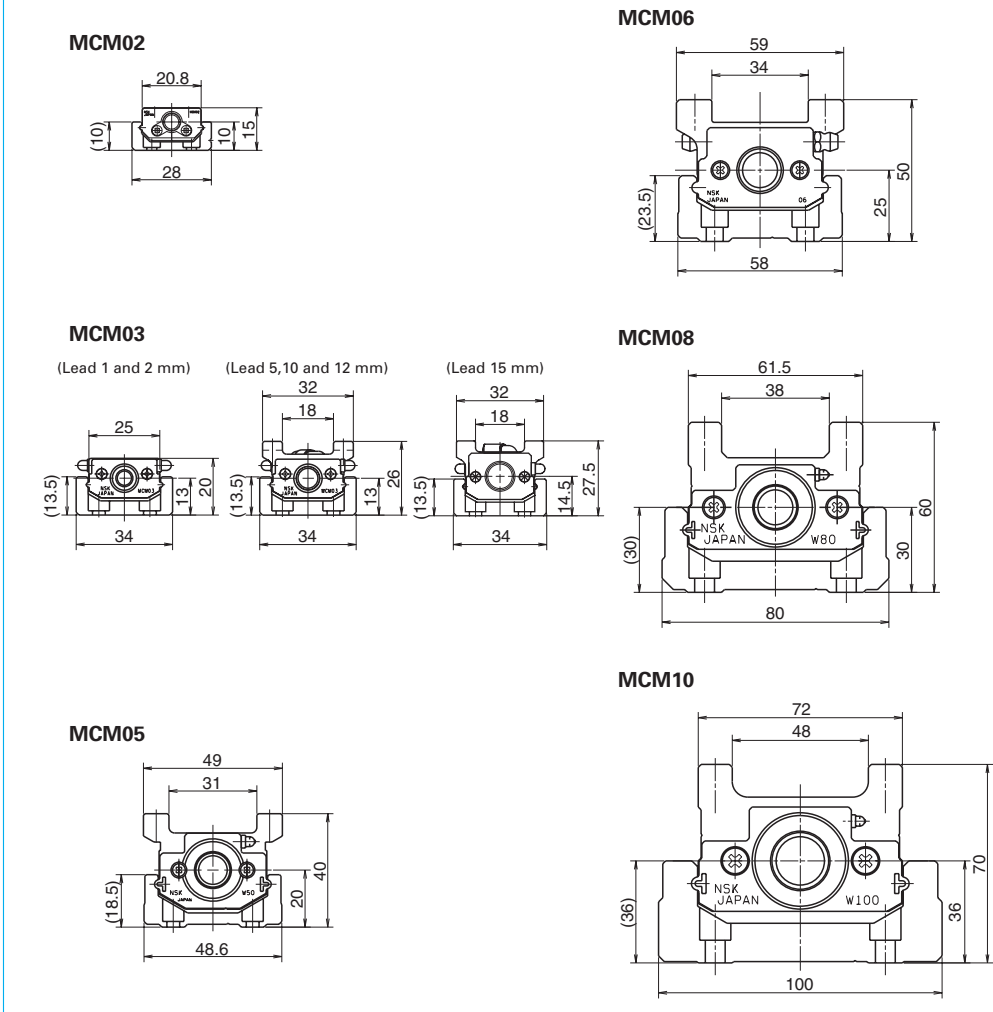

Fig. 2.1

Accuracy	Long Stroke	Size Variation
⊙	○	⊙
⊙	⊙	○

[MCH Series Cross-sections]

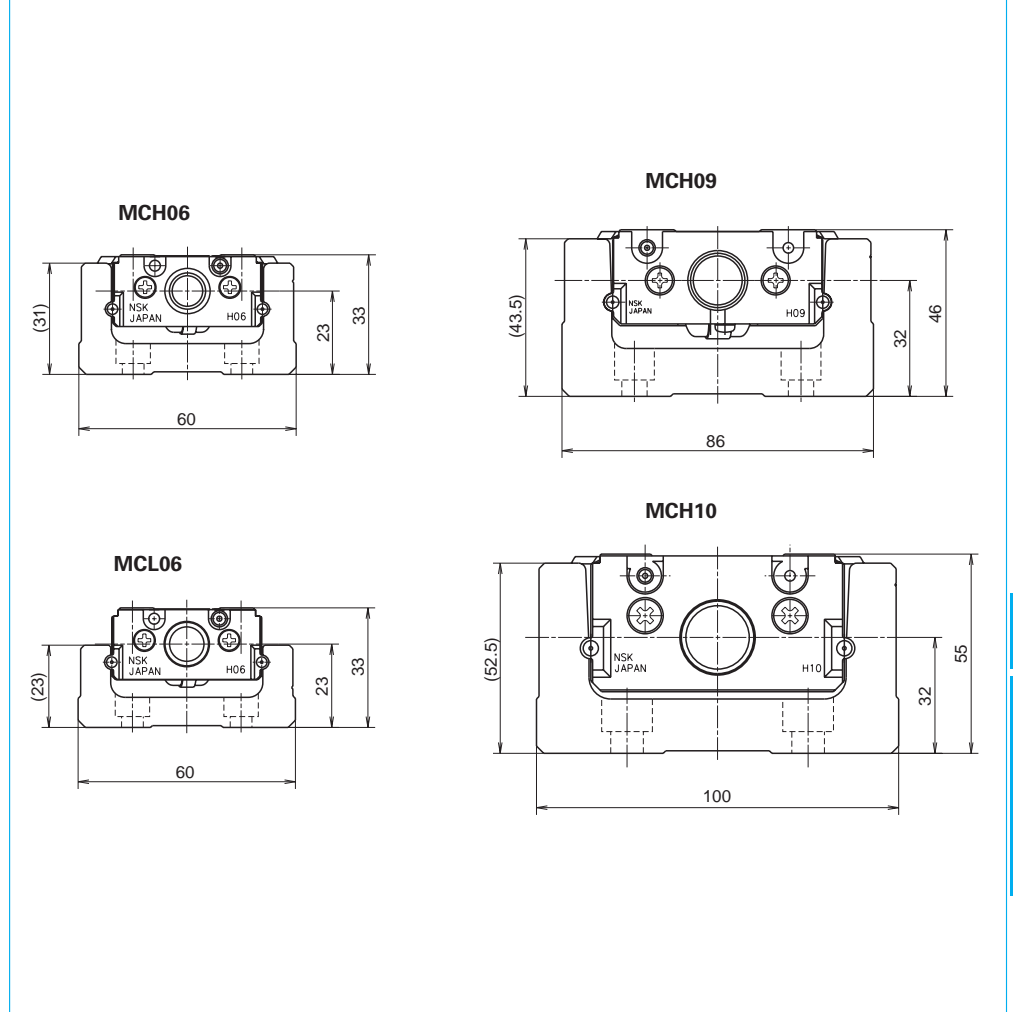

Fig. 2.2

C-1-3 Accessories

MCM Series

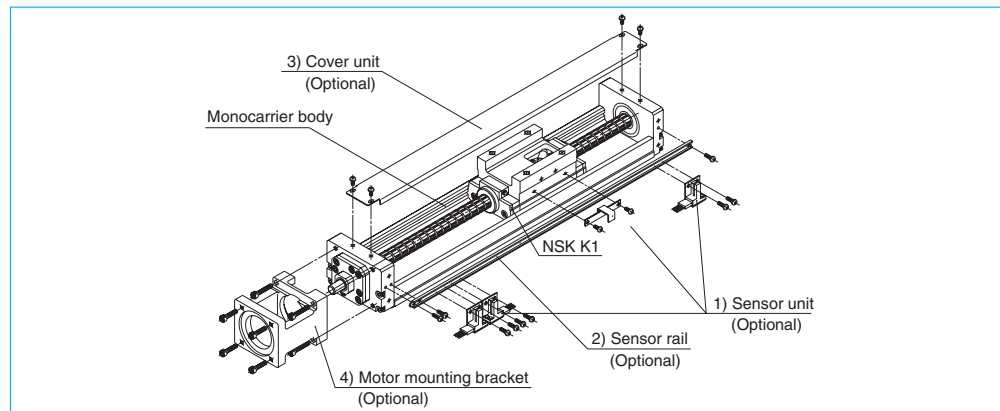

Fig. 3.1 Assembly: Accessories for MCM10 (example)

1) Sensor unit: Sensors, sensor mounting parts and a sensor dog are available in a set.

* When a sensor unit is used, the full cover unit cannot be used.

2) Sensor rail: Rail for sensor mounting is available.

3) Cover unit: Top cover or full cover (included top cover and side cover) is available.

4) Motor bracket for motor mounting: Available for a variety of models.

Note: We assemble accessories upon request.

MCH Series

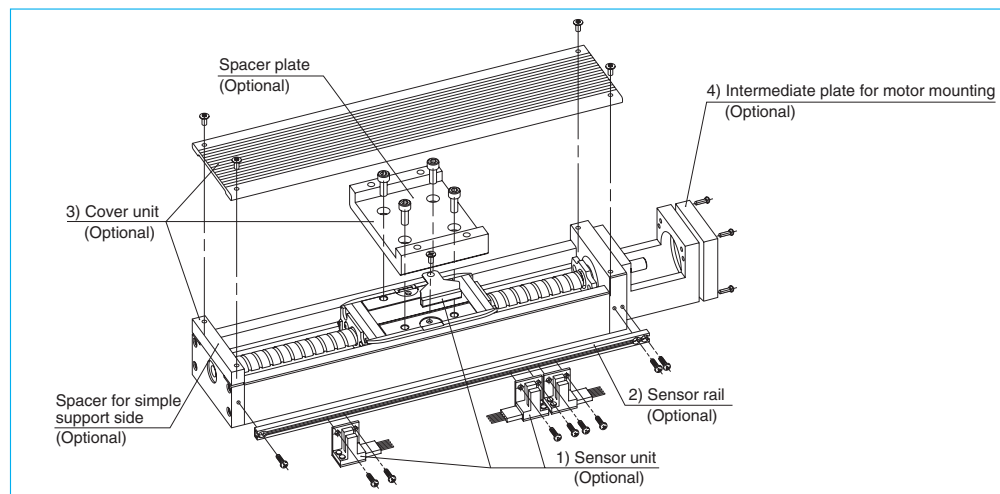

Fig. 3.2 Assembly: Accessories for MCH10 (example)

1) Sensor unit: Sensors, sensor mounting parts and a sensor dog are available in a set.

2) Sensor rail: Rail for sensor mounting is available.

3) Cover unit: Top cover (included spacer plate and spacer for simple support side) is available.

4) Intermediate plate for motor mounting: Available for a variety of models.

Note: We assemble accessories upon request.

C-1-4 Selection of Monocarrier

C-1-4. 1 Procedures for Selecting Monocarrier

Select a model number of Monocarrier based on stroke and rigidity (refer to **Figs. 4.2**, and **4.3**).



Select a ball screw lead referring to "**C-1-4.3 Maximum Speed**" so that the rotational speed does not exceed the limit.



Study the loads to be applied to the linear guide and obtain the equivalent load (F_e) substituting them for equation 1) or 2) on page C17. Obtain the mean effective load (F_m) substituting them for equation 3) on page C18, then calculate the life.



Study the loads to be applied to the ball screw and support unit. Obtain the mean effective load (F_m) substituting them for equation 3) on page C18, then calculate the life.

C-1-4. 2 Rigidity

Rigidity of rail

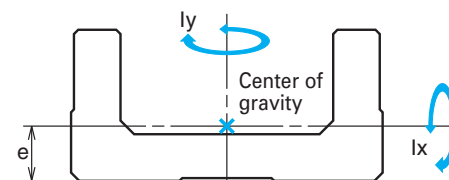

Fig. 4.1

Table 4.1 Rigidity of rail

Model No.	Geometrical moment of inertia $\times 10^4$ (mm ⁴)		Center of gravity (mm)	Mass (kg/100 mm)
	I_x	I_y	e	w
MCM02	0.097	1.32	3.3	0.11
MCM03	0.30	3.3	4.5	0.18
MCM05	0.78	11.4	6.0	0.31
MCM06	2.14	26.1	7.0	0.57
MCM08	5.90	81.0	9.2	0.88
MCM10	15.6	219	12.2	1.52
MCL06	2.58	29.6	7.8	0.56
MCH06	6.5	38.2	10.8	0.67
MCH09	28.7	172	15.5	1.48
MCH10	54.0	307	18	1.93

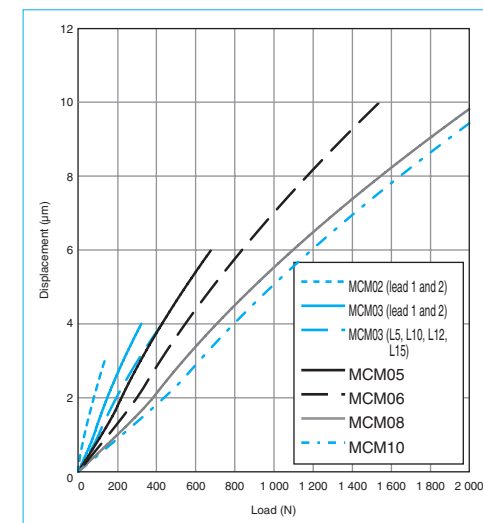

Fig. 4.2 MCM Series rigidity in radial direction

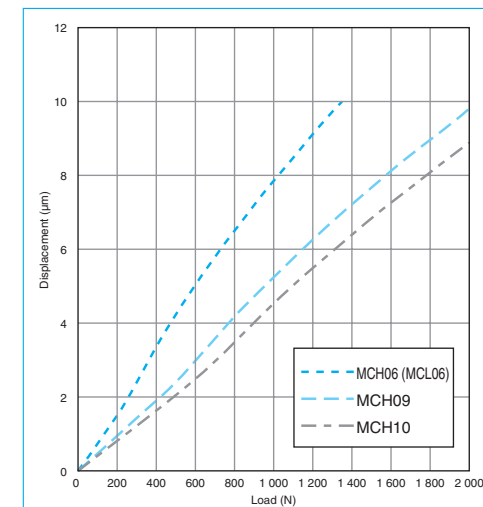

Fig. 4.3 MCH Series rigidity in radial direction

C-1-4. 3 Maximum Speed

(1) Maximum Speed of MCM Series

Maximum speed of Monocarrier is determined by critical speed of ball screw shaft and $d \cdot n$ value.

Do not exceed maximum speeds on the table below.

Table 4.2

	Ball screw lead	Stroke (mm)	Rail length L ₂ (mm)	Maximum speed (mm/s)	
MCM02 Single slider	1	50	100	50	
		100	150		
		150	200		
	2	50	100	100	
		100	150		
		150	200		
MCM03 Single slider	1	50	115	50	
		100	190		
		150	240		
	2	50	115	100	
		100	190		
		150	240		
	5	50	140	250	
		250	340		
		50	140		
		250	340		
		50	140		
		250	340		
10	50	140	500		
	250	340			
	50	140			
12	250	340	600		
	50	140			
15	50	140	750		
	250	340			
MCM05 Single slider	5	50	180	250	
		600	730		
		50	180		
	10	600	730	500	
		50	180		
		600	730		
	20	50	180	1 000	
		600	730		
		300	430		
		400	530		
	30	500	630	2 160	
		600	730		
600		730			
MCM05 Double slider	10	60	280	500	
		510	730		
	20	210	430	1 000	
		510	730		
MCM06 Single slider	5	50	190	250	
		700	840		
		800	940		
	10	50	190	500	
		700	840		
		800	940		
	20	300	440	1 000	
		600	740		
		700	840		
		800	940		
	MCM06 Double slider	5	110	340	250
			410	640	
10		110	340	500	
	710	940			
20	210	440	1 000		
	710	940			

	Ball screw lead	Stroke (mm)	Rail length L ₂ (mm)	Maximum speed (mm/s)	
MCM08 Single slider	5	50	220	250	
		700	870		
		800	970		
	10	50	220	500	
		600	770		
		700	870		
	20	800	970	380	
		50	220		
		600	770		
	30	400	570	2 500	
		500	670		
		600	770		
MCM08 Double slider	10	80	370	500	
		680	970		
		180	470		
	20	680	970	1 000	
		100	280		
		800	980		
	MCM10 Single slider	10	800	1 080	420
			1 000	1 180	
			1 000	1 180	
		20	100	280	1 000
			800	980	
			900	1 080	
30		1 000	1 180	690	
		500	680		
		600	780		
MCM10 Double slider		10	70	380	500
			670	980	
			870	1 180	
	20	170	480	1 000	
		670	980		
		870	1 180		

Note: When operating Monocarriers near critical speed or exceeding maximum speed in the table, please consult NSK.

Note: When operating Monocarriers near critical speed or exceeding maximum speed in the table, please consult NSK.

(2) Maximum Speed of MCH Series

Maximum speed of Monocarrier is determined by critical speed of ball screw shaft and $d \cdot n$ value.

Do not exceed maximum speeds on the table below.

Table 4.3

	Ball screw lead	Stroke (mm)	Rail length L ₂ (mm)	Maximum speed (mm/s)
MCH06 MCL06 Single slider	5	50	150	250
		500	600	
		50	150	
	10	500	600	500
		50	150	
		500	600	
MCH06 Double slider	5	100	300	250
		300	400	
		100	300	
	10	400	600	500
		400	600	
		400	600	
MCH09 Single slider	5	100	240	250
		700	840	
		800	940	
	10	100	240	500
		700	840	
		800	940	
MCH09 Double slider	5	150	440	250
		350	640	
		150	440	
	10	650	940	500
		450	440	
		650	940	
MCH10 Single slider	10	100	280	500
		800	980	
		1 000	1 080	
		1 100	1 180	
		1 200	1 380	
		1 200	1 380	
	20	100	280	1 000
		800	980	
		900	1 080	
		1 000	1 080	
		1 100	1 280	
		1 200	1 380	
MCH10 Double slider	10	250	580	500
		650	980	
		250	580	
		750	1 080	
		850	1 180	
		950	1 280	
	20	250	580	1 000
		650	980	
		850	1 180	
		950	1 280	
		1 050	1 380	
		1 050	1 380	

Note: When operating Monocarriers near critical speed or exceeding maximum speed in the table, please consult NSK.

Note: When operating Monocarriers near critical speed or exceeding maximum speed in the table, please consult NSK.

C-1-4. 4 Accuracy Grade

The accuracy grade of Monocarrier standard series is high grade (H), except for lead 1 and 2 mm of MCM02, and MCM03.

When you require strokes longer than 1 200 mm, please consult NSK about the accuracy grade.

Table 4.4 Unit : μm

Accuracy Stroke (mm)	High grade (H)			Precision (P)			
	Repeatability	Running Parallelism (vertical)	Backlash	Repeatability	Positioning accuracy	Running Parallelism (vertical)	Backlash
- 200	±10	14	20 or less	±3	20	8	3 or less
- 400		16			25	10	
- 600		20			30	12	
- 700		23			30	15	
- 1 000		23			35	15	
- 1 200		30			40	20	

C-1-4. 5 Stroke and Ball Screw Lead

(1) MCM Series Standard Combinations of Stroke and Ball Screw Lead

Table 4.5 Single slider Unit : mm

Model No.	MCM02		MCM03			MCM05			MCM06			MCM08			MCM10								
	Lead	Stroke	1	2	5	10	12	15	5	10	20	30	5	10	20	5	10	20	30	10	20	30	
50	✓	✓	✓	✓	✓	✓	✓	✓	✓	✓	✓	✓	✓	✓	✓	✓	✓	✓	✓	✓	✓	✓	✓
100	✓	✓	✓	✓	✓	✓	✓	✓	✓	✓	✓	✓	✓	✓	✓	✓	✓	✓	✓	✓	✓	✓	✓
150	✓	✓	✓	✓	✓	✓	✓	✓	✓	✓	✓	✓	✓	✓	✓	✓	✓	✓	✓	✓	✓	✓	✓
200					✓	✓	✓	✓	✓	✓	✓	✓	✓	✓	✓	✓	✓	✓	✓	✓	✓	✓	✓
250					✓	✓	✓	✓	✓	✓	✓	✓	✓	✓	✓	✓	✓	✓	✓	✓	✓	✓	✓
300								✓	✓	✓	✓	✓	✓	✓	✓	✓	✓	✓	✓	✓	✓	✓	✓
400								✓	✓	✓	✓	✓	✓	✓	✓	✓	✓	✓	✓	✓	✓	✓	✓
500								✓	✓	✓	✓	✓	✓	✓	✓	✓	✓	✓	✓	✓	✓	✓	✓
600								✓	✓	✓	✓	✓	✓	✓	✓	✓	✓	✓	✓	✓	✓	✓	✓
700									✓	✓	✓	✓	✓	✓	✓	✓	✓	✓	✓	✓	✓	✓	✓
800										✓	✓	✓	✓	✓	✓	✓	✓	✓	✓	✓	✓	✓	✓
900																						✓	✓
1 000																						✓	✓

Table 4.6 Double slider Unit : mm

Model No.	MCM05		MCM06			MCM08			MCM10		
	Lead	Stroke	10	20	5	10	20	10	20	10	20
60	✓										
70											✓
80								✓			
110	✓		✓	✓							
160	✓										
170											✓
180								✓	✓		✓
210	✓	✓	✓	✓	✓						
270											✓
280								✓	✓		
310	✓	✓	✓	✓	✓						✓
370											✓
380								✓	✓		
410	✓	✓	✓	✓	✓						✓
470											✓
480								✓	✓		
510	✓	✓		✓	✓						✓
570											✓
580								✓	✓		
610				✓	✓						
670											✓
680								✓	✓		
710				✓	✓						
870											✓

Note: Please consult NSK about double slider of MCM02 and MCM03.

(2) MCH Series Standard Combinations of Stroke and Ball Screw Lead

Table 4.7 Single slider Unit : mm

Model No.	MCH06		MCH09			MCH10	
	Lead	Stroke	5	10	20	10	20
50	✓	✓	✓				
100	✓	✓	✓	✓	✓	✓	✓
200	✓	✓	✓	✓	✓	✓	✓
300	✓	✓	✓	✓	✓	✓	✓
400	✓	✓	✓	✓	✓	✓	✓
500	✓	✓	✓	✓	✓	✓	✓
600				✓	✓	✓	✓
700				✓	✓	✓	✓
800				✓	✓	✓	✓
900							✓
1 000							✓
1 100							✓
1 200							✓

Table 4.8 Double slider Unit : mm

Model No.	MCH06			MCH09			MCH10	
	Lead	Stroke	5	10	20	5	10	20
100	✓	✓						
150					✓	✓		
200	✓	✓						
250						✓	✓	✓
300	✓	✓						
350					✓	✓		✓
400		✓	✓					
450						✓	✓	✓
550								✓
650						✓	✓	✓
750								✓
850								✓
950								✓
1 050								✓

Table 4.9 Limitations

	Model No.	Lead (mm)	Slider	Stroke (mm)
MCM series	MCM02	1,2	Single	150
		1,2	Single	150
	MCM03	5,10,12,15	Single	350
			Single	900
	MCM05	5,10,20,30*	Double	810
			Single	1 000
	MCM06	5,10,20	Double	910
			Single	1 000
	MCM08	5,10,20,30*	Double	880
			Single	1 750
MCM10	10,20,30*	Double	1 600	
		Single	600	
MCH series	MCH06	5,10,20	Double	500
			Single	1 000
	MCH09	5,10,20	Double	850
			Single	1 750
	MCH10	10,20	Double	1 600
			Single	500
	MCL06	5,10,20	Double	500
			Single	500

*) Applicable only to single slider

C-1-4. 6 Basic Load Rating

(1) MCM Series Basic Load Rating

Table 4.10 Basic Load Rating

Model No.	Lead l (mm)	Shaft dia d (mm)	Basic dynamic load rating (N)				Basic static load rating (N)		Support unit Limit load (N)
			Ball screw C_a	Linear guide C	Support unit C_s	Rated running distance L_a (km)	Ball screw C_{0a}	Linear guide C_0	
MCM02	1	$\phi 6$	340(High grade) 405(Precision)	4 910	615	1	555(High grade) 615(Precision)	2 120	490
			340(High grade) 405(Precision)	3 900			555(High grade) 615(Precision)		
	2			2					
MCM03	1	$\phi 6$	735	10 900	2 670	1	1 230	6 620	1 040
	2		735	8 650		2	2 880		
	5	1 810	7 850	5		1 690			
	10	1 230	6 250	10		2 680			
	12	1 230	5 880	12					
MCM05	5	$\phi 12$	3 760	15 600	4 400	5	6 310	10 900	1 450
	10		2 420	12 400		10	3 790		
	20		2 420	9 850		20	3 790		2 730
	30		3 260	8 600		30	5 400		
MCM06	5	$\phi 15$	7 070	25 200	6 550	5	12 800	17 000	2 730
	10		7 070	20 000		10	12 800		
	20		4 560	15 900		20	7 730		
MCM08	5	$\phi 15$	7 070	30 800	7 100	5	12 800	22 800	3 040
	10		7 070	24 400		10	12 800		
	20		4 560	19 400		20	7 730		
	30		5 070	16 930		30	8 730		
MCM10	10	$\phi 20$	11 000	33 500	7 600	10	21 100	29 400	3 380
	20		7 060	26 600		20	12 700		
	30		11 700	23 200		30	22 700		

Notes: ● Basic dynamic and static load ratings indicate values for one slider. ● Basic load rating of linear guide is load of perpendicular direction to the axis that allows 90% of a group of the same Monocarriers to operate "Rated running distance" in table, that is equivalent to 1 million revolutions of ball screw and support unit under the same conditions without causing flaking by rolling contact fatigue. ● Basic dynamic load rating of ball screw is load in the axial direction that allows 90% of ball screws of a group of the same Monocarriers to rotate 1 million revolutions under the same conditions without causing flaking by rolling contact fatigue. ● Basic dynamic load rating of support unit is constant load in the axial direction that allows 90% of support units of the same group of Monocarriers to rotate 1 million revolutions under the same conditions without causing flaking by rolling contact fatigue. ● Basic static load rating is load that results in combined permanent deformations at contact points of balls and ball grooves of respective parts at a diameter of 0.01%.

Table 4.11 Basic static moment load of linear guide

Model No.	Lead (mm)	Slider	Basic static moment (N · m)		
			Rolling M_{RO}	Pitching M_{PO}	Yawing M_{YO}
MCM02	1, 2	Single	24	8	8
MCM03	1, 2		68	28	28
	5, 10, 12, 15		92	51	51
MCM05	5, 10, 20, 30*	Single	229	89	89
		Double	455	765	765
MCM06	5, 10, 20	Single	415	174	174
		Double	825	1 220	1 220
MCM08	5, 10, 20, 30*	Single	770	300	300
		Double	1 540	2 050	2 050
MCM10	10, 20, 30*	Single	1 170	425	425
		Double	2 340	2 940	2 940

Notes: ● Basic static moment of double slider is value when two sliders equipped with NSK K1 are butted against each other. ● Basic static moment is value when rolling contact pressure of balls exceeds 4 000 N/mm². ● If extremely heavy load is required, please consult NSK for estimation of fatigue life.

*) Applicable only to single slider

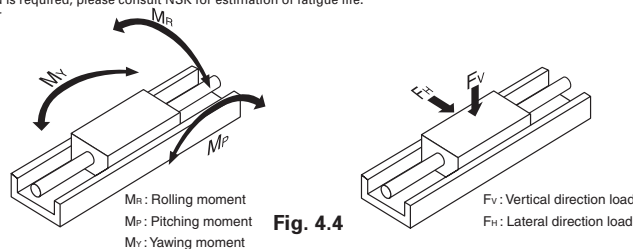

Fig. 4.4

(2) MCH Series Basic Load Rating

Table 4.12 Basic Load Rating

Model No.	Lead l (mm)	Shaft dia d (mm)	Basic dynamic load rating (N)				Basic static load rating (N)		Support unit Limit load (N)	
			Ball screw C_a	Linear guide C	Support unit C_s	Rated running distance L_a (km)	Ball screw C_{0a}	Linear guide C_0		
MCH06 (MCL06)	5	$\phi 12$	3 760	22 800	4 400	5	6 310	16 300	1 450	
	10		2 420	18 100			10			3 790
	20		2 420	14 400			20			3 790
MCH09	5	$\phi 15$	7 070	40 600	7 100	5	12 800	30 500	3 040	
	10		7 070	32 200			10			12 800
	20		4 560	25 500			20			7 730
MCH10	10	$\phi 20$	11 000	44 600	7 600	10	21 100	42 000	3 380	
	20		7 060	35 400			20			12 700

Notes: ● Basic dynamic and static load ratings indicate values for one slider. ● Basic load rating of linear guide is load of perpendicular direction to the axis that allows 90% of a group of the same Monocarriers to operate "Rated running distance" in table, that is equivalent to 1 million revolutions of ball screw and support unit under the same conditions without causing flaking by rolling contact fatigue. ● Basic dynamic load rating of ball screw is load in the axial direction that allows 90% of ball screws of a group of the same Monocarriers to rotate 1 million revolutions under the same conditions without causing flaking by rolling contact fatigue. ● Basic dynamic load rating of support unit is constant load in the axial direction that allows 90% of support units of the same group of Monocarriers to rotate 1 million revolutions under the same conditions without causing flaking by rolling contact fatigue. ● Basic static load rating is load that results in combined permanent deformations at contact points of balls and ball grooves of respective parts at a diameter of 0.01%.

Table 4.13 Basic static moment load of linear guide

Model No.	Slider	Basic static moment (N · m)		
		Rolling M_{RO}	Pitching M_{PO}	Yawing M_{YO}
MCH06 (MCL06)	Single	335	133	133
	Double	770	730	730
MCH09	Single	890	385	385
	Double	1 780	2 070	2 070
MCH10	Single	1 460	610	610
	Double	2 920	3 430	3 430

Notes: ● Basic static moment of double slider is value when two sliders equipped with NSK K1 are butted against each other.

● Basic static moment is value when rolling contact pressure of balls exceeds 4 000 N/mm².

● If extremely heavy load is required, please consult NSK for estimation of fatigue life.

*) Applicable only to single slider

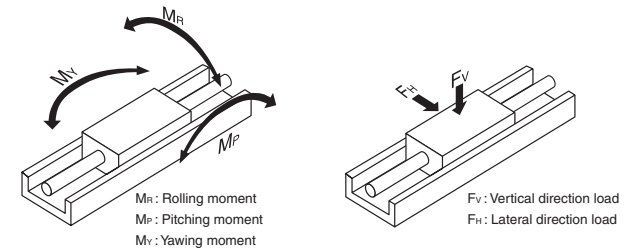

Fig. 4.5

C-1-4. 7 Estimation of Life Expectancy

(1) Life of Linear Guide

Study the load to be applied to the linear guide of Monocarrier (Fig. 4.6). The equivalent load (Fe) is determined by substituting the load for equation 1) (Eq. 2): in case of the tightly coupled double slider type.

● In case of the single slider

$$F_e = Y_H F_H + Y_V F_V + Y_R \epsilon_R M_R + Y_P \epsilon_P M_P + Y_Y \epsilon_Y M_Y \dots\dots\dots 1)$$

● In case of the double slider

$$F_e = \frac{Y_H F_H}{2} + \frac{Y_V F_V}{2} + Y_R \epsilon_{Rd} M_R + Y_P \epsilon_{Pd} M_P + Y_Y \epsilon_{Yd} M_Y \dots\dots\dots 2)$$

- F_H : Lateral direction load acting on the slider (N)
- F_V : Vertical direction load acting on the slider (N)
- M_R : Rolling moment acting on the slider (N · m)
- M_P : Pitching moment acting on the slider (N · m)
- M_Y : Yawing moment acting on the slider (N · m)

- ε_{Rr} ε_{Rd} : Dynamic equivalent coefficient to rolling moment
- ε_{Pr} ε_{Pd} : Dynamic equivalent coefficient to pitching moment
- ε_{Yr} ε_{Yd} : Dynamic equivalent coefficient to yawing moment

Refer to **Table 4.14** about Dynamic equivalent coefficient.

- Y_{Hr} Y_{Vr} Y_{Rr} Y_{Pr} Y_{Yr} : 1.0 or 0.5

At equations 1) and 2) for obtaining equivalent load Fe, among F_H, F_V, ε_PM_P, ε_RM_R, ε_YM_Y, the maximum load is assumed to be 1.0, and others are to be 0.5.

Table 4.14 Dynamic equivalent coefficient

Model No.	MCM02	MCM03		MCM05	MCM06	MCM08	MCM10	MCH06 MCL06	MCH09	MCH10
		Lead 1, 2	Lead 5, 10, 12, 15							
ε _R	95.2	79.4	79.4	52.6	45.5	32.5	27.8	48.3	34.5	28.6
ε _P	174	113.9	84.2	81.3	65.1	48.8	45.2	75.1	47.9	41.0
ε _Y	174	113.9	84.2	81.3	65.1	48.8	45.2	75.1	47.9	41.0
ε _{Rd}	-	-	-	26.3	22.7	16.3	13.9	24.2	17.2	14.3
ε _{Pd}	-	-	-	10.4 (12.2)	9.7 (11.5)	7.6 (8.6)	7.1 (8.0)	11.4 (13.2)	8.11 (9.10)	6.98 (7.82)
ε _{Yd}	-	-	-	10.4 (12.2)	9.7 (11.5)	7.6 (8.6)	7.1 (8.0)	11.4 (13.2)	8.11 (9.10)	6.98 (7.82)

Note: Parenthesized figures are dynamic equivalent coefficient in case of the Monocarrier without NSK K1.

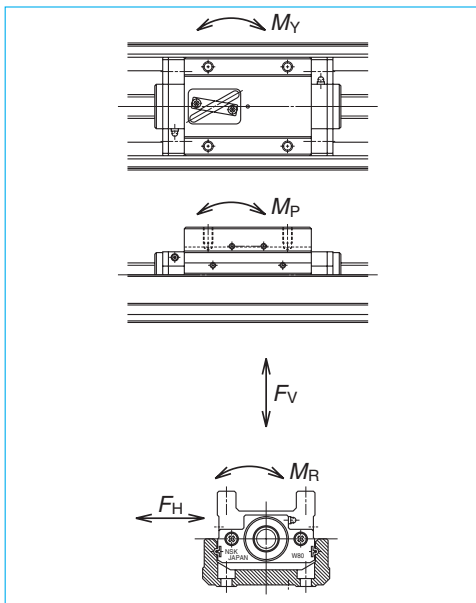

Fig. 4.6 Direction of load

In case when the load acting on the slider may fluctuate (In general, M_r, M_y may fluctuate with the acceleration/deceleration of slider), the mean effective load is determined by Eq. 3).

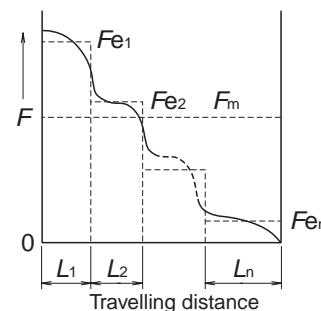

Fig. 4.7 Stepwise Fluctuating Load

Travelling distance under the equivalent load Fe₁ : L₁
 Travelling distance under the equivalent load Fe₂ : L₂

 Travelling distance under the equivalent load Fe_n : L_n

$$F_m = \sqrt[3]{\frac{1}{L} (F_{e1}^3 L_1 + F_{e2}^3 L_2 + \dots + F_{en}^3 L_n) \dots 3)}$$

F_m : Mean effective load of fluctuating loads
 L : Total travelling distance

The life of linear guide is calculated by Eq. 4).

$$L = L_a \times \left(\frac{C}{f_w \cdot F_m} \right)^3 \dots\dots\dots 4)$$

- L : Life of linear guide (km)
- F_m : Mean effective load acting on the linear guide (N)
- C : Basic dynamic load rating of the linear guide (N)
- L_a : Travelling distance (km)
- f_w : Load factor (refer to **Table 4.15**)

When the estimated life does not clear the required life, the life of the linear guide is to be calculated again after the following measures are taken:

1. Change from the single slider type to double slider type.
2. Use a larger size Monocarrier.

(2) Life of Ball Screw (Support unit)

The mean effective load is determined from the axial loads.

For calculation of the mean effective load, use Eq. 3.

The life of ball screw is calculated by Eq. 5).

$$L = \ell \times \left(\frac{C_a}{f_w \cdot F_m} \right)^3 \times 10^6 \dots\dots\dots 5)$$

- ℓ : Lead of ball screw (mm)
- L : Life of ball screw (mm)
- C_a : Basic dynamic load rating of the ball screw (N)
- F_m : Mean effective load acting on the ball screw (N)
- f_w : Load factor (refer to **Table 4.15**)

The life of a support unit is calculated by Eq. 5). If the life of ball screw/support unit does not clear the required life, use a larger size Monocarrier. After applying the calculations mentioned above, selection of the Monocarrier is completed.

Table 4.15 Values of load factor f_w

Operating conditions	Load factor f _w
At smooth operation with no mechanical shock	1.0 – 1.2
At normal operation	1.2 – 1.5
At operation with mechanical shock and vibrations	1.5 – 3.0

C-1-4. 8 Example of Life Estimation

This section offers an example how to estimate the life of Monocarrier based on the life of each component.

<<Example of calculation-1>>

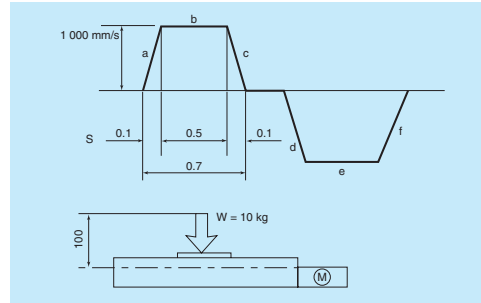

Fig. 4.8

1. Use condition

- Stroke : 600 mm
- Maximum speed : 1000 mm/s
- Load mass : W = 10 kg
- Acceleration : g = 9.80 m/s²
- Setting position : Horizontal
- Operating profile : See above figure

2. Selection of Model number (Interim Selection)

Firstly, select a greater ball screw lead as the maximum speed is 1000 mm/s. The interim selection is MCM06060H20K00, a single slider specification MCM06 that has 600 mm stroke, as the stroke is 600 mm.

3. Calculation

3-1. Linear guide

3-1-1. Fatigue life:

Multiply the result of the Eq. 1) by the dynamic equivalent coefficient (Table 4.14 single slider) to convert the load volume. From above operation profile,

- i) Constant speed $Fe_1 = Y_V \cdot F_V = Y_V \cdot W \cdot g = 1 \cdot 10 \cdot 9.8 = 98 \text{ N}$
- ii) Accelerating $Fe_2 = Y_V \cdot F_V + Y_P \cdot \epsilon_P \cdot M_P = 0.5 \cdot 10 \cdot 9.8 + 1 \cdot 65.1 \cdot 0.1 \cdot 100 = 700 \text{ N}$
- iii) Decelerating $Fe_3 = Y_V \cdot F_V + Y_P \cdot \epsilon_P \cdot M_P = 0.5 \cdot 10 \cdot 9.8 + 1 \cdot 65.1 \cdot 0.1 \cdot 100 = 700 \text{ N}$

Mean effective load F_m

$$F_m = \sqrt[3]{\frac{1}{L} (Fe_1^3 \cdot L_1 + Fe_2^3 \cdot L_2 + Fe_3^3 \cdot L_3)}$$

$$= \sqrt[3]{\frac{1}{600} (98^3 \cdot 500 + 700^3 \cdot 50 + 700^3 \cdot 50)}$$

$$= 387 \text{ N}$$

$$L = \left(\frac{C_a}{f_w \cdot F_m} \right)^3 \times L_a$$

$$= \left(\frac{15900}{1.2 \cdot 387} \right)^3 \times 20$$

$$= 8.02 \times 10^5 \text{ km}$$

3-1-2. Static safety factor: Divide the basic static load rating by the maximum load.

$$F_s = \frac{C_0}{F_e} = \frac{C_0}{F_e} = \frac{17000}{700} = 24.2$$

3-2. Ball screw

3-2-1. Fatigue life: Obtain the axial load of each stage of operation referring to the operation profile, then calculate the mean load.

By the process above,

- i) Constant speed $Fe_1 = \mu \cdot W \cdot g = 0.01 \cdot 10 \cdot 9.8 = 0.98$
- ii) Accelerating $Fe_2 = Fe_1 + W \cdot \alpha = 101 \text{ N}$
- iii) Decelerating $Fe_3 = Fe_1 - W \cdot \alpha = 99 \text{ N}$

Axial mean effective load F_m

$$F_m = \sqrt[3]{\frac{1}{L} (Fe_1^3 \cdot L_1 + Fe_2^3 \cdot L_2 + Fe_3^3 \cdot L_3)}$$

$$= \sqrt[3]{\frac{1}{600} (0.98^3 \cdot 500 + 101^3 \cdot 50 + 99^3 \cdot 50)}$$

$$= 55 \text{ N}$$

$$L = \left(\frac{C_a}{f_w \cdot F_m} \right)^3 \times \ell \times 10^6$$

$$= \left(\frac{4560}{1.2 \cdot 55} \right)^3 \times 20 \times 10^6 \text{ (mm)}$$

$$= 6.5 \times 10^6 \text{ km}$$

3-2-2. Static safety factor: Divide the basic static load rating by the maximum axial load.

$$F_s = \frac{C_0a}{F_e} = \frac{C_0a}{F_e} = \frac{7730}{101} = 76.5$$

3-2-3. Maximum rotational speed: According to the table of maximum speed on page C9, MCM06 with 20 mm lead and 600 mm stroke, is possible to operate under the maximum speed

of 1 000 mm/s.

3-3. Support unit

3-3-1. Fatigue life: Use the axial load $F_m = 55 \text{ N}$, that is the result of above calculation 3-2-1.

$$L = \left(\frac{C_a}{f_w \cdot F_m} \right)^3 \times \ell \times 10^6 = \left(\frac{6550}{1.2 \times 55} \right)^3 \times 20 \times 10^6 \text{ (mm)}$$

$$= 1.95 \times 10^7 \text{ km}$$

3-3-2. Static safety factor: Divide the limit load by the maximum axial load.

$$F_s = \frac{C_0a}{F_e} = \frac{C_0a}{F_e} = \frac{2730}{101} = 27.0$$

3-4. Result

MCM06060H20K00	Linear guide	Ball screw	Support unit
	8.02 × 10 ⁵ km	6.5 × 10 ⁶ km	1.95 × 10 ⁷ km
	24.2	76.5	27.0

In this case, the linear guide has the shortest fatigue life of the components. Therefore, the linear guide fatigue life is used as the life of the Monocarrier. The interim selection of MCM06060H20K00, that is chosen based on the use conditions, satisfies the required life.

<<Example of calculation-2>>

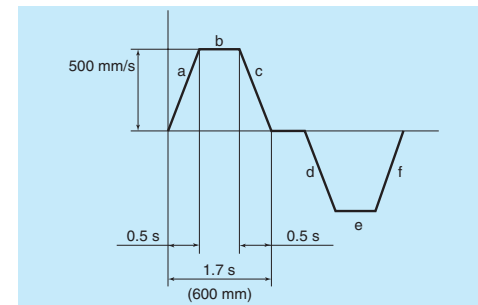

Fig. 4.9

1. Use condition

- Stroke : 600 mm
- Maximum speed : 500 mm/s
- Load mass : W = 20 kg
- Acceleration : 9.8 m/s²
- Setting position : Horizontal
- Operating profile : See above figure

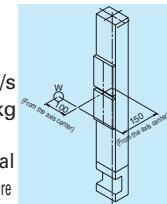

Fig. 4.10

2. Selection of Model number (Interim Selection)

Select a 10 mm lead ball screw as the maximum

speed is 500 mm/s.

The interim selection is MCM08068H10D00 as a double slider specification of MCM08 has 680 mm stroke, and the setting position is vertical.

3. Calculation

3-1. Linear guide

3-1-1. Fatigue life: Multiply the result of the Eq. 2) by the dynamic equivalent coefficient (Table 4.14. double slider) to convert the load volume. From operation profile (Fig. 4.9), the acceleration is 1 m/s².

- i) Constant speed $Fe_1 = Y_P \cdot \epsilon_{Pd} \cdot M_P + Y_V \cdot \epsilon_{Vd} \cdot M_V = 1 \cdot 7.6 \cdot 20 \cdot 9.8 \cdot 0.15 + 0.5 \cdot 7.6 \cdot 20 \cdot 9.8 \cdot 0.1 = 298 \text{ N}$
- ii) Accelerating $Fe_2 = Y_P \cdot \epsilon_{Pd} \cdot M_P + Y_V \cdot \epsilon_{Vd} \cdot M_V = 1 \cdot 7.6 \cdot 20 \cdot (9.8 + 1.0) \cdot 0.15 + 0.5 \cdot 7.6 \cdot 20 \cdot (9.8 + 1.0) \cdot 0.1 = 329 \text{ N}$
- iii) Decelerating $Fe_3 = Y_P \cdot \epsilon_{Pd} \cdot M_P + Y_V \cdot \epsilon_{Vd} \cdot M_V = 1 \cdot 7.6 \cdot 20 \cdot (9.8 - 1.0) \cdot 0.15 + 0.5 \cdot 7.6 \cdot 20 \cdot (9.8 - 1.0) \cdot 0.1 = 268 \text{ N}$

Mean effective load F_m

$$F_m = \sqrt[3]{\frac{1}{L} (Fe_1^3 \cdot L_1 + Fe_2^3 \cdot L_2 + Fe_3^3 \cdot L_3)}$$

$$= \sqrt[3]{\frac{1}{600} (298^3 \cdot 350 + 329^3 \cdot 125 + 268^3 \cdot 125)}$$

$$= 300 \text{ N}$$

$$L = L_a \times \left(\frac{C_a}{f_w \cdot F_m} \right)^3$$

$$= 10 \times \left(\frac{24400}{1.2 \cdot 300} \right)^3$$

$$= 3.11 \times 10^6 \text{ km}$$

3-1-2. Static safety factor: Divide the basic static load rating by the maximum load.

$$F_s = \frac{C_0}{F_e} = \frac{C_0}{F_e} = \frac{22800}{329} = 69.3$$

3-2. Ball screw

3-2-1. Fatigue life: Obtain the axial load of each stage of operation referring to the operation profile, then calculate the mean load.

- i) Constant speed $Fe_1 = W \cdot g = 20 \cdot 9.8 = 196 \text{ N}$
- ii) Accelerating $Fe_2 = Fe_1 + W \cdot \alpha = 196 + 20 \cdot 1 = 216 \text{ N}$
- iii) Decelerating $Fe_3 = Fe_1 - W \cdot \alpha = 196 - 20 \cdot 1 = 176 \text{ N}$

Axial mean effective load F_m

$$F_m = \sqrt[3]{\frac{1}{L} (Fe_1^3 \cdot L_1 + Fe_2^3 \cdot L_2 + Fe_3^3 \cdot L_3)}$$

$$= \sqrt[3]{\frac{1}{600} (196^3 \cdot 350 + 216^3 \cdot 125 + 176^3 \cdot 125)}$$

$$= 197 \text{ N}$$

$$L = \ell \times \left(\frac{C_a}{f_w \cdot F_m} \right)^3 \times 10^6$$

$$= 10 \times \left(\frac{7\,070}{1.2 \cdot 197} \right)^3 \times 10^6 \text{ (mm)}$$

$$= 2.67 \times 10^5 \text{ km}$$

3-2-2. Static safety factor: Divide the basic static load rating by the maximum axial load.

$$F_s = \frac{C_{0a}}{F_e} = \frac{C_{0a}}{F_{e2}} = \frac{12\,800}{216} = 59.2$$

3-3. Support unit

3-3-1. Fatigue life: Use the axial load $F_m = 197 \text{ N}$, that is the result of above calculation 3-2-1.

$$L = \ell \times \left(\frac{C_a}{f_w \cdot F_m} \right)^3 \times 10^6 = 10 \times \left(\frac{7\,100}{1.2 \times 197} \right)^3 \times 10^6 \text{ (mm)}$$

$$= 2.70 \times 10^5 \text{ km}$$

3-3-2. Static safety factor: Divide the limit load by the maximum axial load.

$$F_s = \frac{C_{0a}}{F_e} = \frac{C_{0a}}{F_{e2}} = \frac{3\,040}{216} = 14.0$$

3-4. Result

MCM08068H10D00	Linear guide	Ball screw	Support unit
Fatigue life	3.11 × 10 ⁶ km	2.67 × 10 ⁶ km	2.70 × 10 ⁶ km
Static safety factor	69.3	59.2	14.0



C-1-5 MCM Series

1 MCM Series Reference Number C25
Coding

2 MCM Series Dimension Table of
Standard Products

MCM02 C26

MCM03 C27

MCM05 C31

MCM06 C35

MCM08 C39

MCM10 C43

3 MCM Series Accessories

3.1 Sensor Unit C47

3.2 Cover Unit C51

3.3 Motor Bracket C53

MCM Series

C-1-5 MCM Series

C-1-5.1 MCM Series Reference Number Coding

[Body]

Example: **MC M 08 040 H 10 K 0 0** *1

Monocarrier

M type: MCM Series

Nominal size (rail width, Unit: 10 mm)

Stroke (Unit: 10 mm)

Accuracy grade (H, high grade; P, precision grade)

NSK management number (0 or 2)

Standard grease specification: O (AS2)
Clean grease specification: B (LG2)

Slider specification K: Single slider
D: Double slider (See page C13.)

Ball screw lead (mm)

Note: *1. 14th digit is control No. of NSK. Customers cannot specify a number. See the pages of each nominal number for details.

[With Accessories]

Example: **MC E 08 040 H 10 K 0 0 K 0 0 0**

E: With MCM Accessories

NSK management number

Sensor unit

Cover unit

Motor bracket

Note: Accessories are available separately.

Table 1 Sensor unit (See page C47.)

Reference No. code	Specification	Reference No.
0	N/A	—
1	Proximity switch (normally close contact 3 pieces)	MC - SRxx - 10
2	Proximity switch (normally open contact 3 pieces)	MC - SRxx - 11
3	Proximity switch (normally open contact 1 piece, normally close contact 2 pieces)	MC - SRxx - 12
4	Photo sensor 3 pieces	MC - SRxx - 13

Note 1) xx: Reference number
2) Sensor rail is not included in sensor unit. If you require the rail, please request separately. (See page C48 to C50.)

Table 2 Cover unit (See pages C51 to C52.)

Reference No. code	Specification	Reference No.
0	N/A	—
1	With top cover	MC - CVxxxx - 01 (02) *
—	Full cover	MC - CVxxxx - 00

Note 1) xxxxx: Reference number and stroke number 2)*: "-02" is only used for Monocarrier MCM03.
3) When a sensor unit is used, full cover unit cannot be used.

Table 3 Motor bracket (See pages C53 to C69.)

Reference No. code	Reference No.				
	MCM03	MCM05	MCM06	MCM08	MCM10
0	N/A	N/A	N/A	N/A	N/A
1	MC-BK03-146-00	MC-BK05-145-00	MC-BK06-145-00	MC-BK08-145-00	MC-BK10-170-00
2	MC-BK03-148-01	MC-BK05-146-00	MC-BK06-146-00	MC-BK08-146-00	MC-BK10-170-01
3	MC-BK03-231-00	MC-BK05-148-00	MC-BK06-148-00	MC-BK08-160-00	MC-BK10-190-00
4	—	MC-BK05-160-00	MC-BK06-160-00	MC-BK08-170-00	MC-BK10-270-00
5	—	MC-BK05-250-00	MC-BK06-170-00	MC-BK08-170-01	—
6	—	—	MC-BK06-170-01	MC-BK08-190-00	—
7	—	—	MC-BK06-250-00	MC-BK08-250-00	—
8	—	—	—	MC-BK08-270-00	—

N/A: Not applicable

C-1-5.2 MCM Series Dimension Table of Standard Products

MCM02

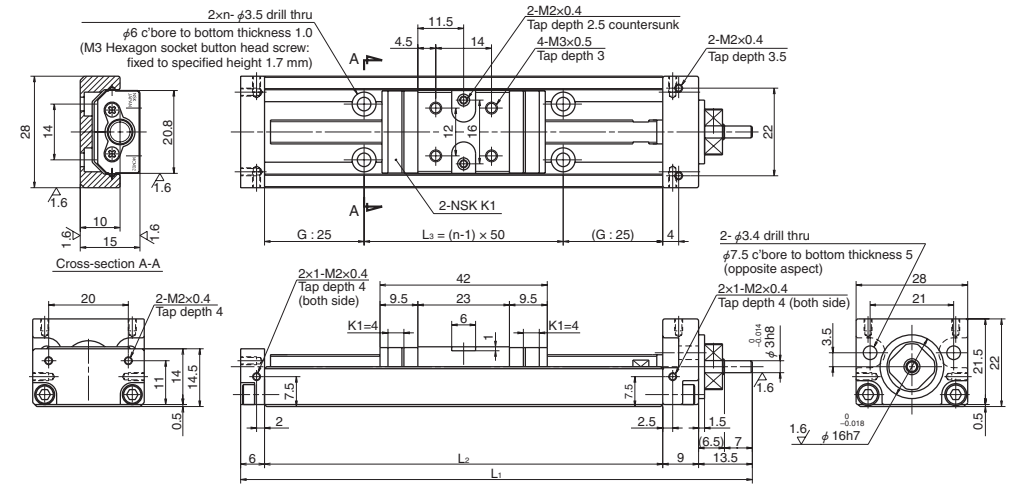

Dimension of MCM02 (Single slider)

Reference No.	Nominal stroke (mm)	Stroke limit (mm)	Ball screw lead (mm)	Body length (mm)			No. of mounting hole n	Inertia $\times 10^{-7}$ (kg · m ²)	Mass (kg)
				L ₁	L ₂	L ₃			
MCM02005H01K	50	58	1	128.5	100	50	2	0.93	0.26
MCM02005P01K									
MCM02005H02K			2						
MCM02005P02K									
MCM02010H01K	100	108	1	178.5	150	100	3	1.36	0.32
MCM02010P01K									
MCM02010H02K			2						
MCM02010P02K									
MCM02015H01K	150	158	1	228.5	200	150	4	1.81	0.39
MCM02015P01K									
MCM02015H02K			2						
MCM02015P02K									

Monocarrier dynamic torque specification (N · cm)

Ball screw lead (mm)	High grade		Precision	
	1	0.1 - 1.3	0.2 - 1.6	
2			0.1 - 1.3	0.2 - 1.6

Notes:

1. Frictional resistance of NSK K1 is included in dynamic torque in table.
2. Grease is packed into ball screw, linear guide parts and support unit.
3. Consult NSK for life estimates under large moment loads.
4. There is no LG2 specification for MCM02.

Basic load rating

Lead l (mm)	Shaft dia d (mm)	Basic dynamic load rating (N)				Basic static load rating (N)		Support unit load limit (N)
		Ball screw C_a	Linear guides C	Support unit C_a	Rated running distance L_a (km)	Ball screw C_{0a}	Linear guides C_0	
1	$\phi 6$	340 (High grade)	4 910	615	1	555 (High grade)	2 120	490
		405 (Precision)				615 (Precision)		
2	$\phi 6$	340 (High grade)	3 900		2	555 (High grade)		
		405 (Precision)				615 (Precision)		

Basic static moment load of linear guide

Slider	Basic static moment load (N · m)		
	Rolling M_{R0}	Pitching M_{P0}	Yawing M_{Y0}
Single	24	8	8

MCM03

Accuracy grade: Precision (P)

Ball screw lead 1 and 2

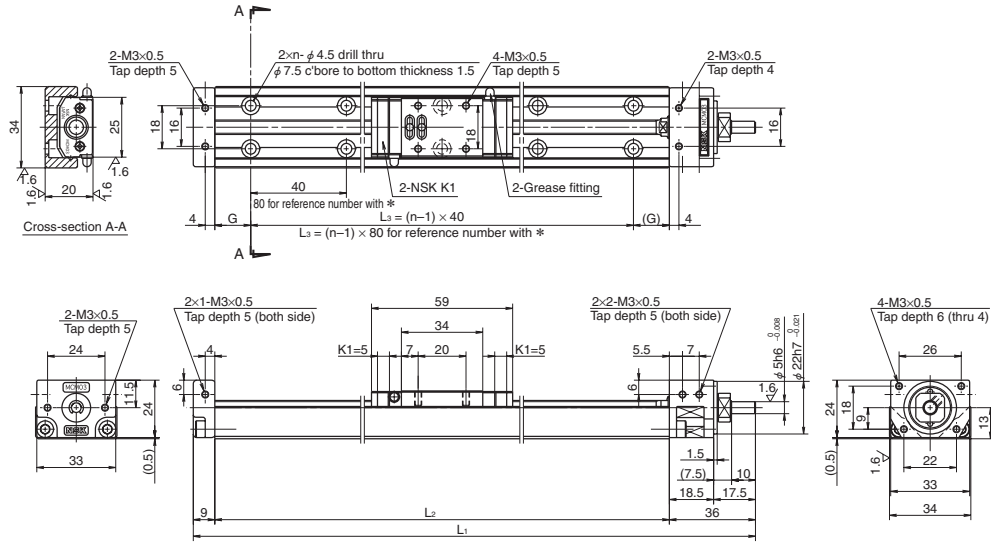

Dimension of MCM03 (Single slider)

Reference No.	Nominal stroke (mm)	Stroke limit (mm) (without K1)	Ball screw lead (mm)	Body length (mm)				No. of mounting hole <i>n</i>	Inertia $\times 10^5$ (kg · m ²)	Mass (kg)
				L ₁	L ₂	G	L ₃			
*MCM03005P01K00	50	56	1	160	115	17.5	80	2	0.015	0.6
*MCM03005P02K00		(66)	2							
MCM03010P01K00	100	131	1	235	190	15	160	5	0.021	0.7
MCM03010P02K00		(141)	2							
MCM03015P01K00	150	181	1	285	240	20	200	6	0.025	0.8
MCM03015P02K00		(191)	2							

Note: Bolt hole pitch L₃ on items marked with * is 80 mm.

Monocarrier dynamic torque specification (N · cm)

Ball screw lead (mm)	1	0.2 - 1.7
	2	

Notes:

- Frictional resistance of NSK K1 is included in dynamic torque in table.
- Grease is packed into ball screw, linear guide parts and support unit.
- Consult NSK for life estimates under large moment loads.
- A spacer plate is required when using a cover unit or sensor unit for MCM03 with the lead of 1 or 2 mm. (See page C51.)

Basic load rating

Lead <i>l</i> (mm)	Shaft dia <i>d</i> (mm)	Basic dynamic load rating (N)				Basic static load rating (N)		Support unit load limit (N)
		Ball screw <i>C_a</i>	Linear guides <i>C</i>	Support unit <i>C_s</i>	Rated running distance <i>L_a</i> (km)	Ball screw <i>C_{0a}</i>	Linear guides <i>C₀</i>	
1	φ 6	735	10 900	2 670	1	1 230	4 900	1 040
2					2			

Basic static moment load of linear guide

Slider	Basic static moment load (N · m)		
	Rolling M _{RO}	Pitching M _{PO}	Yawing M _{VO}
Single	68	28	28

MCM03

Accuracy grade: High grade (H)

Ball screw lead 5, 10 and 12

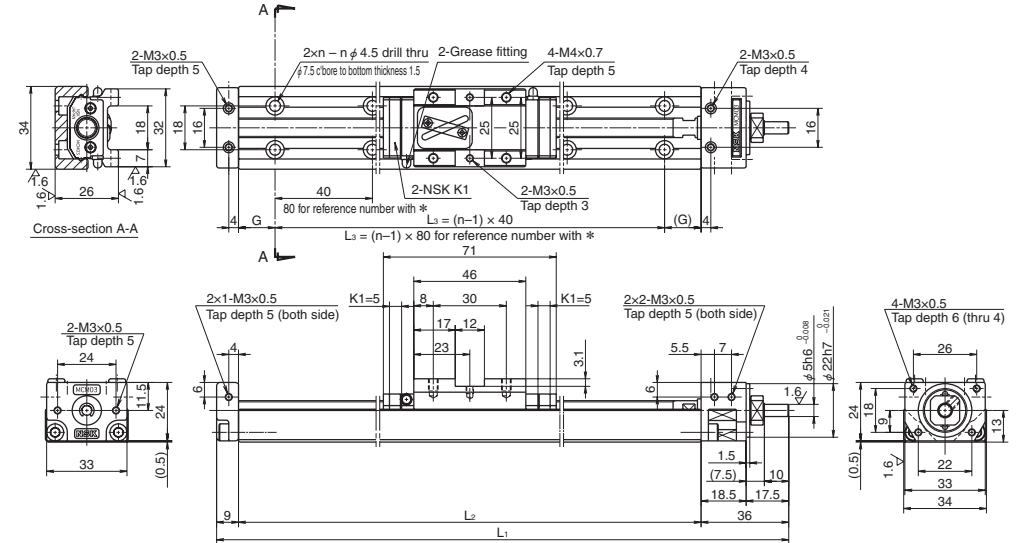

Dimension of MCM03 (Single slider)

Reference No.	Nominal stroke (mm)	Stroke limit (mm) (without K1)	Ball screw lead (mm)	Body length (mm)				No. of mounting hole <i>n</i>	Inertia $\times 10^5$ (kg · m ²)	Mass (kg)
				L ₁	L ₂	G	L ₃			
*MCM03005H05K00	50	69 (79)	5	185	140	30	80	2	0.057	0.6
*MCM03005H10K00			10						0.080	
*MCM03005H12K00			12						0.097	
MCM03010H05K00	100	119 (129)	5	235	190	15	160	5	0.073	0.7
MCM03010H10K00			10						0.092	
MCM03010H12K00			12						0.109	
MCM03015H05K00	150	169 (179)	5	285	240	20	200	6	0.089	0.8
MCM03015H10K00			10						0.105	
MCM03015H12K00			12						0.122	
MCM03020H05K00	200	219 (229)	5	335	290	25	240	7	0.104	0.9
MCM03020H10K00			10						0.118	
MCM03020H12K00			12						0.135	
MCM03025H05K00	250	269 (279)	5	385	340	30	280	8	0.120	1.0
MCM03025H10K00			10						0.131	
MCM03025H12K00			12						0.147	

Note: Bolt hole pitch L₃ on items marked with * is 80 mm.

Monocarrier dynamic torque specification (N · cm)

Ball screw lead (mm)	5	0.2 - 2.5
	10	
	12	0.3 - 3.0

Notes:

- Frictional resistance of NSK K1 is included in dynamic torque in table.
- Grease is packed into ball screw, linear guide parts and support unit.
- Consult NSK for life estimates under large moment loads.

Basic load rating

Lead <i>l</i> (mm)	Shaft dia <i>d</i> (mm)	Basic dynamic load rating (N)				Basic static load rating (N)		Support unit load limit (N)
		Ball screw <i>C_a</i>	Linear guides <i>C</i>	Support unit <i>C_s</i>	Rated running distance <i>L_a</i> (km)	Ball screw <i>C_{0a}</i>	Linear guides <i>C₀</i>	
5	φ 8	1 810	7 850	2 670	5	2 880	6 620	1 040
10					10			
12					12			

Basic static moment load of linear guide

Slider	Basic static moment load (N · m)		
	Rolling M _{RO}	Pitching M _{PO}	Yawing M _{VO}
Single	92	51	51

MCM03

Ball screw lead 15

Accuracy grade: High grade (H)

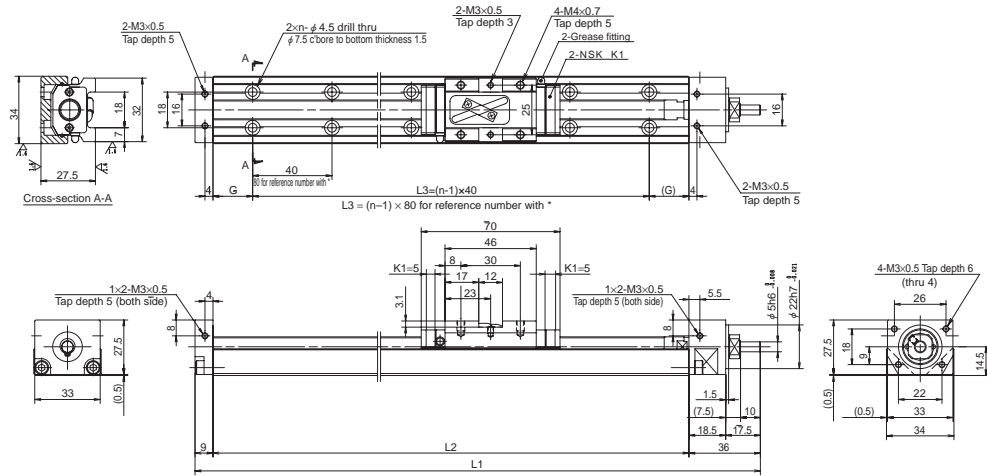

Dimension of MCM03 (Single slider)

Reference No.	Nominal stroke (mm)	Stroke limit (without K1)	Ball screw lead (mm)	Ball screw diameter (mm)	Body length (mm)				No. of mounting hole <i>n</i>	Inertia ×10 ⁻⁴ (kg·m ²)	Mass (kg)
					L ₁	L ₂	G	L ₃			
* MCM03005H15K00	50	70 (80)			185	140	30	80	2	0.183	0.67
MCM03010H15K00	100	120(130)			235	190	15	160	5	0.222	0.77
MCM03015H15K00	150	170(180)	15	φ 10	285	240	20	200	6	0.260	0.87
MCM03020H15K00	200	220(230)			335	290	25	240	7	0.298	0.97
MCM03025H15K00	250	270(280)			385	340	30	280	8	0.336	1.07

Note: Bolt hole pitch L₃ on items marked with * is 80 mm.

Monocarrier dynamic torque specification (N · cm)		
Ball screw lead (mm)	15	0.3 – 5.6

Notes:

1. Frictional resistance of NSK K1 is included in dynamic torque in table.
2. Grease is packed into ball screw, linear guide parts and support unit.
3. Consult NSK for life estimates under large moment loads.
4. When a cover unit is added, an optional spacer plate is required. (See page C51.)
5. There is no P grade (precision grade) for Lead 15.

Basic load rating

Lead <i>l</i> (mm)	Shaft dia <i>d</i> (mm)	Basic dynamic load rating (N)				Rated running distance <i>L_a</i> (km)	Basic static load rating (N)		Support unit load limit (N)
		Ball screw <i>C_a</i>	Linear guides <i>C</i>	Support unit <i>C_a</i>	Ball screw <i>C_{0a}</i>		Linear guide <i>C₀</i>		
15	φ 10	1 760	5 440	2 670	15	2 680	6 620	1 040	

Basic static load of linear guide

Slider	Basic static moment load (N · m)		
	Rolling M _{RO}	Pitching M _{PO}	Yawing M _{YO}
Single	92	51	51

MCM05

Accuracy grade: High grade (H)

Ball screw lead 5, 10 and 20

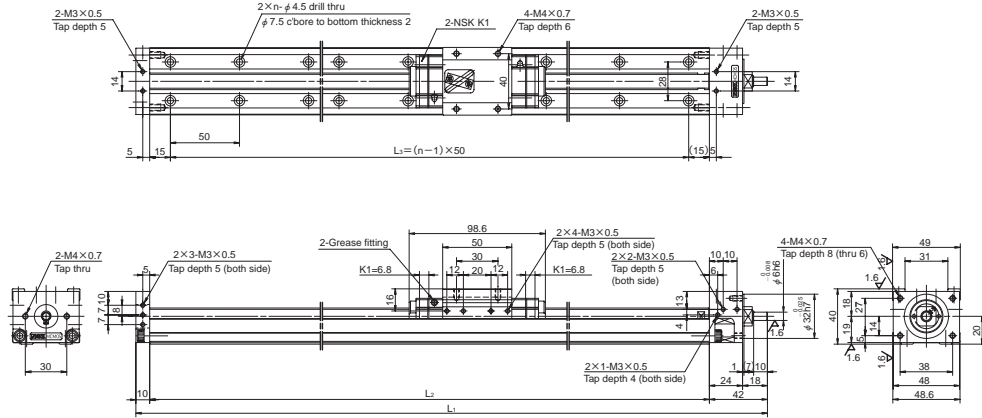

Dimension of MCM05 (Single slider)

Reference No.	Nominal stroke (mm)	Stroke limit (mm) (without K1)	Ball screw lead (mm)	Body length (mm)			No. of mounting hole <i>n</i>	Inertia $\times 10^{-4}$ (kg · m ²)	Mass (kg)
				L ₁	L ₂	L ₃			
MCM05005H05K00	50	81 (95)	5	232	180	150	4	0.025	1.4
MCM05005H10K00			10						
MCM05005H20K00			20						
MCM05010H05K00	100	131 (145)	5	282	230	200	5	0.031	1.6
MCM05010H10K00			10						
MCM05010H20K00			20						
MCM05015H05K00	150	181 (195)	5	332	280	250	6	0.036	1.8
MCM05015H10K00			10						
MCM05015H20K00			20						
MCM05020H05K00	200	231 (245)	5	382	330	300	7	0.042	2.0
MCM05020H10K00			10						
MCM05020H20K00			20						
MCM05025H05K00	250	281 (295)	5	432	380	350	8	0.047	2.2
MCM05025H10K00			10						
MCM05025H20K00			20						

Monocarrier dynamic torque specification (N · cm)

Ball screw lead (mm)	5	1.0 – 4.8
10	1.1 – 5.8	
20	1.6 – 7.9	
30	1.8 – 13.1	

Notes:

- Frictional resistance of NSK K1 is included in dynamic torque in table.
- Grease is packed into ball screw, linear guide parts and support unit.
- Consult NSK for life estimates under large moment loads.

Basic load rating

Lead <i>l</i> (mm)	Shaft dia <i>d</i> (mm)	Basic dynamic load rating (N)				Basic static load rating (N)		Support unit load limit (N)
		Ball screw <i>C_a</i>	Linear guides <i>C</i>	Support unit <i>C_a</i>	Rated running distance <i>L_a</i> (km)	Ball screw <i>C_{0a}</i>	Linear guides <i>C₀</i>	
5	φ 12	3 760	15 600	4 400	5	6 310	10 900	1 450
10		2 420	12 400		10	3 790		
20		2 420	9 850		20	3 790		
30		3 260	8 600	30	5 400			

Basic static moment load of linear guide

Slider	Basic static moment load (N · m)		
	Rolling M _{RO}	Pitching M _{PO}	Yawing M _{VO}
Single	229	89	89

MCM05

Accuracy grade: High grade (H)

Ball screw lead 30

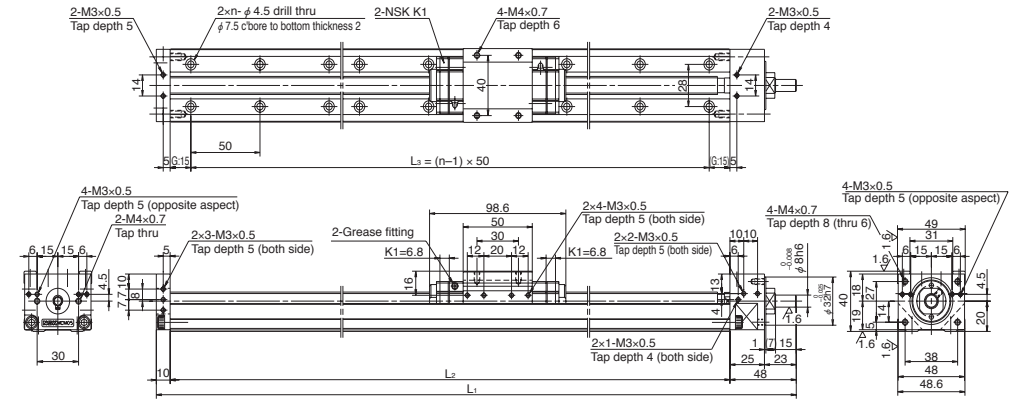

Dimension of MCM05 (Single slider)

Reference No.	Nominal stroke (mm)	Stroke limit (mm) (without K1)	Ball screw lead (mm)	Body length (mm)			No. of mounting hole <i>n</i>	Inertia $\times 10^{-4}$ (kg · m ²)	Mass (kg)
				L ₁	L ₂	L ₃			
MCM05030H05K00	300	331 (345)	5	482	430	400	9	0.053	2.3
MCM05030H10K00			10						
MCM05030H20K00			20						
MCM05030H30K00			30						
MCM05040H05K00	400	431 (445)	5	582	530	500	11	0.064	2.7
MCM05040H10K00			10						
MCM05040H20K00			20						
MCM05040H30K00			30						
MCM05050H05K00	500	531 (545)	5	682	630	600	13	0.076	3.1
MCM05050H10K00			10						
MCM05050H20K00			20						
MCM05050H30K00			30						
MCM05060H05K00	600	631 (645)	5	782	730	700	15	0.087	3.5
MCM05060H10K00			10						
MCM05060H20K00			20						
MCM05060H30K00			30						

Monocarrier dynamic torque specification (N · cm)

Ball screw lead (mm)	5	1.0 – 4.8
10	1.1 – 5.8	
20	1.6 – 7.9	
30	1.8 – 13.1	

Notes:

- Frictional resistance of NSK K1 is included in dynamic torque in table.
- Grease is packed into ball screw, linear guide parts and support unit.
- Consult NSK for life estimates under large moment loads.

Basic load rating

Lead <i>l</i> (mm)	Shaft dia <i>d</i> (mm)	Basic dynamic load rating (N)				Basic static load rating (N)		Support unit load limit (N)
		Ball screw <i>C_a</i>	Linear guides <i>C</i>	Support unit <i>C_a</i>	Rated running distance <i>L_a</i> (km)	Ball screw <i>C_{0a}</i>	Linear guides <i>C₀</i>	
5	φ 12	3 760	15 600	4 400	5	6 310	10 900	1 450
10		2 420	12 400		10	3 790		
20		2 420	9 850		20	3 790		
30		3 260	8 600	30	5 400			

Basic static moment load of linear guide

Slider	Basic static moment load (N · m)		
	Rolling M _{RO}	Pitching M _{PO}	Yawing M _{VO}
Single	229	89	89

MCM05 (Double slider)

Accuracy grade: High grade (H)

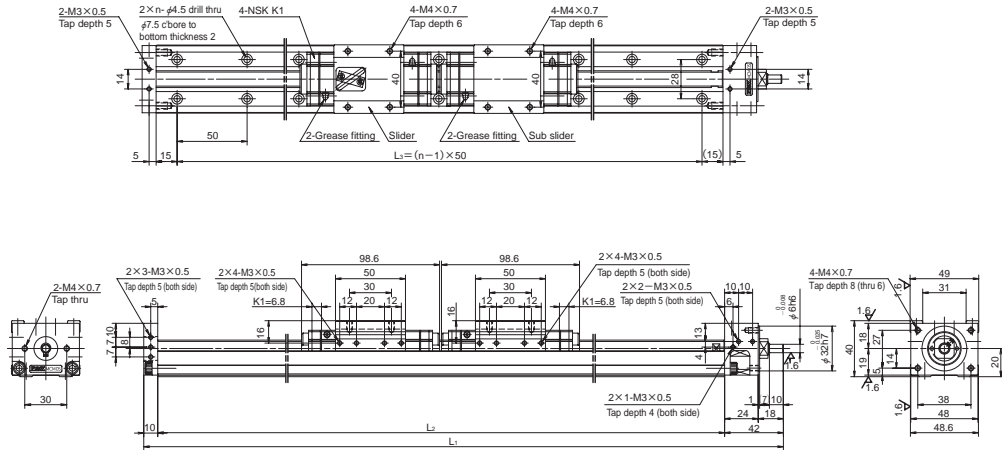

MCM05 (Double slider)

Accuracy grade: High grade (H)

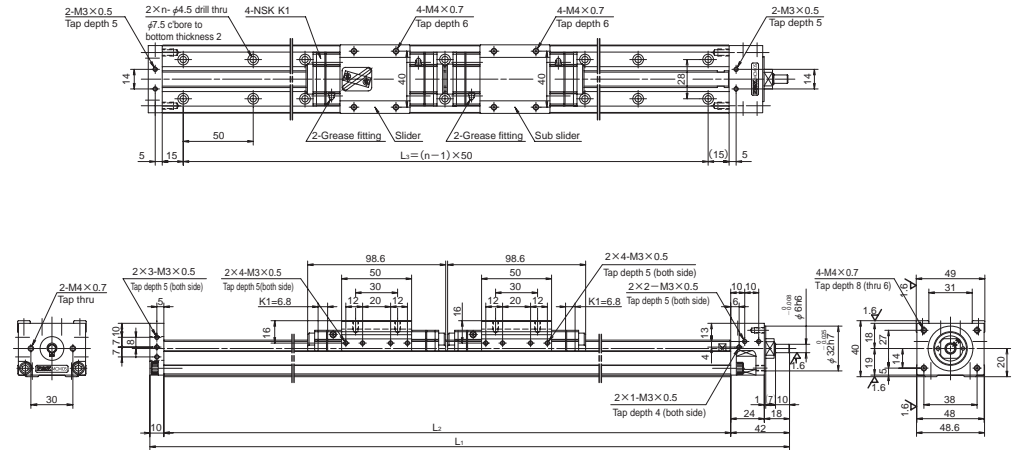

Dimension of MCM05 (Double slider)

Reference No.	Nominal stroke (mm)	Stroke limit (mm) (without K1)	Ball screw lead (mm)	Body length (mm)			No. of mounting hole <i>n</i>	Inertia ×10 ⁻⁴ (kg·m ²)	Mass (kg)
				L ₁	L ₂	L ₃			
MCM05006H10D00	60	82 (110)	10	332	280	250	6	0.058	2.3
MCM05011H10D00	110	132 (160)	10	382	330	300	7	0.064	2.5
MCM05016H10D00	160	182 (210)	10	432	380	350	8	0.070	2.7
MCM05021H10D00	210	232	10	482	430	400	9	0.075	2.8
MCM05021H20D00		(260)	20					0.151	

Dimension of MCM05 (Double slider)

Reference No.	Nominal stroke (mm)	Stroke limit (mm) (without K1)	Ball screw lead (mm)	Body length (mm)			No. of mounting hole <i>n</i>	Inertia ×10 ⁻⁴ (kg·m ²)	Mass (kg)
				L ₁	L ₂	L ₃			
MCM05031H10D00	310	332 (360)	10	582	530	500	11	0.086	3.2
MCM05031H20D00			20					0.162	
MCM05041H10D00	410	432 (460)	10	682	630	600	13	0.098	3.6
MCM05041H20D00			20					0.174	
MCM05051H10D00	510	532 (560)	10	782	730	700	15	0.109	4.2
MCM05051H20D00			20					0.185	

Monocarrier dynamic torque specification (N·cm)

Ball screw lead (mm)	Notes:	
	10	1.5 - 7.6
20	2.3 - 11.8	

- Notes:
- Frictional resistance of NSK K1 is included in dynamic torque in table.
 - Grease is packed into ball screw, linear guide parts and support unit.
 - Consult NSK for life estimates under large moment loads.

Monocarrier dynamic torque specification (N·cm)

Ball screw lead (mm)	Notes:	
	10	1.5 - 7.6
20	2.3 - 11.8	

- Notes:
- Frictional resistance of NSK K1 is included in dynamic torque in table.
 - Grease is packed into ball screw, linear guide parts and support unit.
 - Consult NSK for life estimates under large moment loads.

Basic load rating

Lead <i>l</i> (mm)	Shaft dia <i>d</i> (mm)	Basic dynamic load rating (N)				Basic static load rating (N)		Support unit load limit (N)	
		Ball screw <i>C_a</i>	Linear guides <i>C</i>	Support unit <i>C_a</i>	Rated running distance <i>L_a</i> (km)	Ball screw <i>C_{0a}</i>	Linear guides <i>C₀</i>		
5	φ 12	3 760	15 600	4 400	5	6 310	10 900	1 450	
10		2 420	12 400		10				3 790
20		2 420	9 850		20				3 790

Basic static moment load of linear guide

Slider	Basic static moment load (N·m)		
	Rolling M _{RO}	Pitching M _{PO}	Yawing M _{YO}
Double	455	765	765

Basic load rating

Lead <i>l</i> (mm)	Shaft dia <i>d</i> (mm)	Basic dynamic load rating (N)				Basic static load rating (N)		Support unit load limit (N)	
		Ball screw <i>C_a</i>	Linear guides <i>C</i>	Support unit <i>C_a</i>	Rated running distance <i>L_a</i> (km)	Ball screw <i>C_{0a}</i>	Linear guides <i>C₀</i>		
5	φ 12	3 760	15 600	4 400	5	6 310	10 900	1 450	
10		2 420	12 400		10				3 790
20		2 420	9 850		20				3 790

Basic static moment load of linear guide

Slider	Basic static moment load (N·m)		
	Rolling M _{RO}	Pitching M _{PO}	Yawing M _{YO}
Double	455	765	765

MCM06

Accuracy grade: High grade (H)

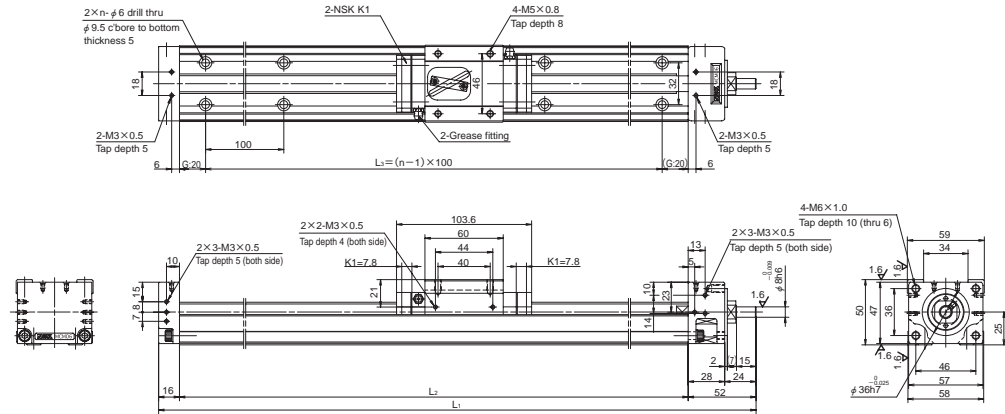

Dimension of MCM06 (Single slider)

Reference No.	Nominal stroke (mm)	Stroke limit (mm) (without K1)	Ball screw lead (mm)	Body length (mm)			No. of mounting hole n	Inertia $\times 10^{-4}$ (kg · m ²)	Mass (kg)
				L_1	L_2	L_3			
◇MCM06005H05K02	50	86 (102)	5	258	190	100	2	0.066	2.7
◇MCM06005H10K00			10					0.077	
◇MCM06005H20K00			20					0.122	
MCM06010H05K02	100	136 (152)	5	308	240	200	3	0.080	3.0
MCM06010H10K00			10					0.092	
MCM06010H20K00			20					0.137	
◇MCM06015H05K02	150	186 (202)	5	358	290	200	3	0.095	3.5
◇MCM06015H10K00			10					0.106	
◇MCM06015H20K00			20					0.152	
MCM06020H05K02	200	236 (252)	5	408	340	300	4	0.110	3.8
MCM06020H10K00			10					0.121	
MCM06020H20K00			20					0.167	
◇MCM06025H05K02	250	286 (302)	5	458	390	300	4	0.125	4.2
◇MCM06025H10K00			10					0.136	
◇MCM06025H20K00			20					0.181	
MCM06030H05K02	300	336 (352)	5	508	440	400	5	0.139	4.5
MCM06030H10K00			10					0.150	
MCM06030H20K00			20					0.196	

Notes: 1. Dimension G is 45 for items marked with ◇.
2. The nominal number in the above table is for high-grade grease specifications. In the case of other specifications, see the following table for the 13th and 14th digits.

Coding for columns 13 and 14

Grease	Lead	High-grade, precision-grade
Standard	5	02
	10, 20	00
LG2	5	B2
	10, 20	B0

Notes:

- Frictional resistance of NSK K1 is included in dynamic torque in table.
- Grease is packed into ball screw, linear guide parts and support unit.
- Consult NSK for life estimates under large moment loads.

Ball screw lead (mm)	Monocarrier dynamic torque specification (N · cm)	
	5	1.9 – 7.4
10	2.2 – 8.6	
	2.8 – 11.0	

Basic load rating

Lead l (mm)	Shaft dia d (mm)	Basic dynamic load rating (N)				Basic static load rating (N)		Support unit load limit (N)
		Ball screw C_a	Linear guides C	Support unit C_a	Rated running distance L_a (km)	Ball screw C_{0a}	Linear guides C_0	
5	$\phi 15$	7 070	25 200	6 550	5	12 800	17 000	2 730
10		7 070	20 000		10	12 800		
20		4 560	15 900		20	7 730		

Basic static moment load of linear guide

Slider	Basic static moment load (N · m)		
	Rolling M_{RO}	Pitching M_{PO}	Yawing M_{YO}
Single	415	174	174

Accuracy grade: High grade (H)

MCM06

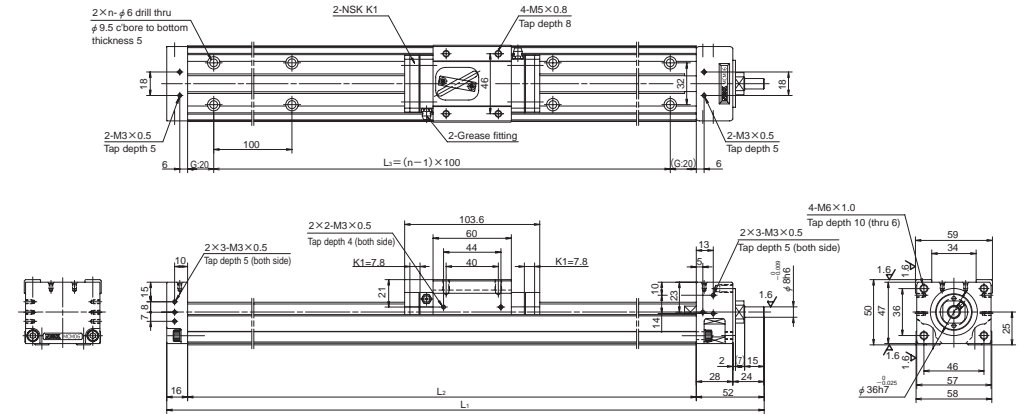

Dimension of MCM06 (Single slider)

Reference No.	Nominal stroke (mm)	Stroke limit (mm) (without K1)	Ball screw lead (mm)	Body length (mm)			No. of mounting hole n	Inertia $\times 10^{-4}$ (kg · m ²)	Mass (kg)
				L_1	L_2	L_3			
MCM06040H05K02	400	436 (452)	5	608	540	500	6	0.169	5.2
MCM06040H10K00			10					0.180	
MCM06040H20K00			20					0.225	
MCM06050H05K02	500	536 (552)	5	708	640	600	7	0.198	6.0
MCM06050H10K00			10					0.209	
MCM06050H20K00			20					0.255	
MCM06060H05K02	600	636 (652)	5	808	740	700	8	0.228	6.7
MCM06060H10K00			10					0.239	
MCM06060H20K00			20					0.284	
MCM06070H05K02	700	736 (752)	5	908	840	800	9	0.257	7.4
MCM06070H10K00			10					0.268	
MCM06070H20K00			20					0.314	
MCM06080H05K02	800	836 (852)	5	1 008	940	900	10	0.286	8.1
MCM06080H10K00			10					0.298	
MCM06080H20K00			20					0.343	

Note: The nominal number in the above table is for high-grade grease specifications. In the case of other specifications, see the following table for the 13th and 14th digits.

Coding for columns 13 and 14

Grease	Lead	High-grade, precision-grade
Standard	5	02
	10, 20	00
LG2	5	B2
	10, 20	B0

Basic load rating

Lead l (mm)	Shaft dia d (mm)	Basic dynamic load rating (N)				Basic static load rating (N)		Support unit load limit (N)
		Ball screw C_a	Linear guides C	Support unit C_a	Rated running distance L_a (km)	Ball screw C_{0a}	Linear guides C_0	
5	$\phi 15$	7 070	25 200	6 550	5	12 800	17 000	2 730
10		7 070	20 000		10	12 800		
20		4 560	15 900		20	7 730		

Basic static moment load of linear guide

Slider	Basic static moment load (N · m)		
	Rolling M_{RO}	Pitching M_{PO}	Yawing M_{YO}
Single	415	174	174

MCM06 (Double slider)

Accuracy grade: High grade (H)

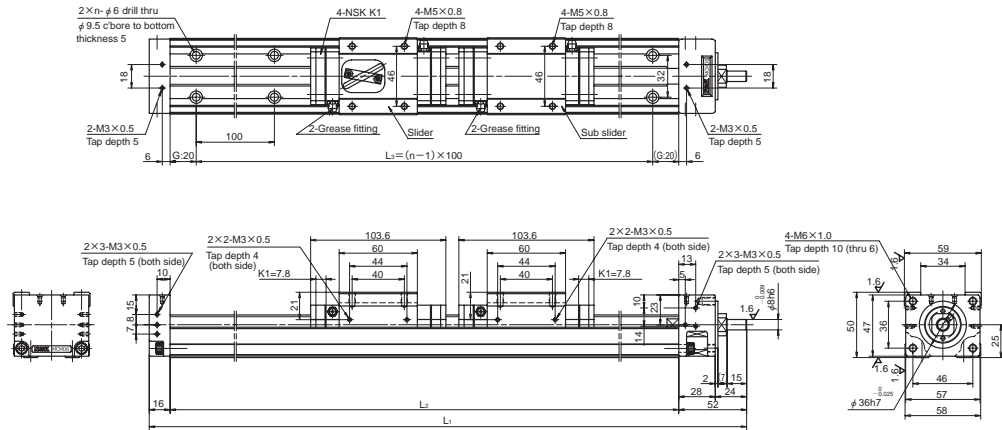

MCM06 (Double slider)

Accuracy grade: High grade (H)

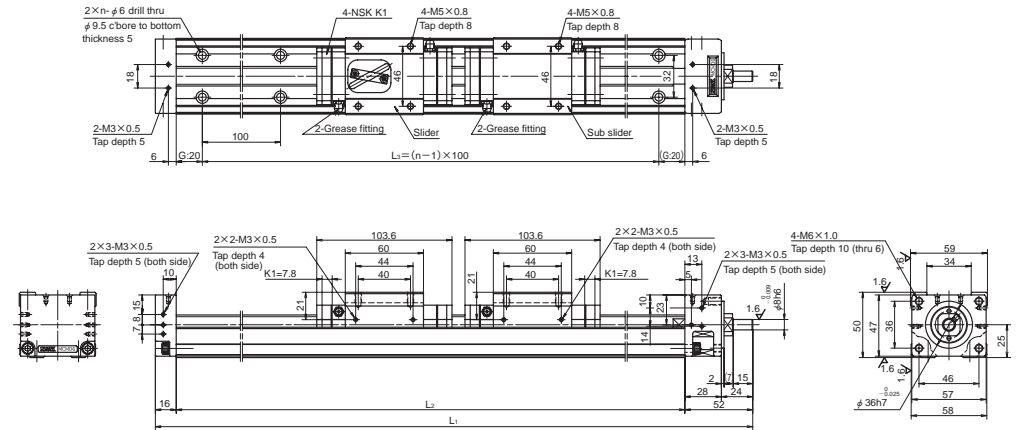

Dimension of MCM06 (Double slider)

Reference No.	Nominal stroke (mm)	Stroke limit (mm) (without K1)	Ball screw lead (mm)	Body length (mm)			No. of mounting hole n	Inertia $\times 10^4$ (kg · m ²)	Mass (kg)
				L ₁	L ₂	L ₃			
MCM06011H05D02	110	132 (164)	5	408	340	300	4	0.114	4.4
MCM06011H10D00			10						
MCM06021H05D02	210	232 (264)	5	508	440	400	5	0.143	5.1
MCM06021H10D00			10						
MCM06021H20D00			20						
MCM06031H05D02	310	332 (364)	5	608	540	500	6	0.173	5.8
MCM06031H10D00			10						
MCM06031H20D00			20						

Note: The nominal number in the above table is for high-grade grease specifications. In the case of other specifications, see the following table for the 13th and 14th digits.

Coding for columns 13 and 14

Grease	Lead	High-grade, precision-grade
Standard	5	02
	10, 20	00
LG2	5	B2
	10, 20	B0

Monocarrier dynamic torque specification (N · cm)

Ball screw lead (mm)	Notes:	
	5	2.3 – 8.5
	10	2.7 – 10.9
20	4.0 – 15.9	

- Frictional resistance of NSK K1 is included in dynamic torque in table.
- Grease is packed into ball screw, linear guide parts and support unit.
- Consult NSK for life estimates under large moment loads.

Basic load rating

Lead l (mm)	Shaft dia d (mm)	Basic dynamic load rating (N)				Basic static load rating (N)			Support unit load limit (N)
		Ball screw C_a	Linear guides C	Support unit C_a	Rated running distance L_a (km)	Ball screw C_{0a}	Linear guides C_0		
5	$\phi 15$	7 070	25 200	6 550	5	12 800	17 000	2 730	
10		7 070	20 000		10	12 800			
20		4 560	15 900		20	7 730			

Basic static moment load of linear guide

Slider	Basic static moment load (N · m)		
	Rolling M_{RO}	Pitching M_{PO}	Yawing M_{YO}
Double	825	1 220	1 220

Dimension of MCM06 (Double slider)

Reference No.	Nominal stroke (mm)	Stroke limit (mm) (without K1)	Ball screw lead (mm)	Body length (mm)			No. of mounting hole n	Inertia $\times 10^4$ (kg · m ²)	Mass (kg)
				L ₁	L ₂	L ₃			
MCM06041H05D02	410	432 (464)	5	708	640	600	7	0.202	6.6
MCM06041H10D00			10						
MCM06041H20D00			20						
MCM06051H10D02	510	532 (564)	10	808	740	700	8	0.254	7.3
MCM06051H20D00			20						
MCM06061H10D02	610	632 (664)	10	908	840	800	9	0.283	8.0
MCM06061H20D00			20						
MCM06071H10D02	710	732 (764)	10	1 008	940	900	10	0.313	8.7
MCM06071H20D00			20						

Note: The nominal number in the above table is for high-grade grease specifications. In the case of other specifications, see the following table for the 13th and 14th digits.

Coding for columns 13 and 14

Grease	Lead	High-grade, precision-grade
Standard	5	02
	10, 20	00
LG2	5	B2
	10, 20	B0

Monocarrier dynamic torque specification (N · cm)

Ball screw lead (mm)	Notes:	
	5	2.3 – 8.5
	10	2.7 – 10.9
20	4.0 – 15.9	

- Frictional resistance of NSK K1 is included in dynamic torque in table.
- Grease is packed into ball screw, linear guide parts and support unit.
- Consult NSK for life estimates under large moment loads.

Basic load rating

Lead l (mm)	Shaft dia d (mm)	Basic dynamic load rating (N)				Basic static load rating (N)			Support unit load limit (N)
		Ball screw C_a	Linear guides C	Support unit C_a	Rated running distance L_a (km)	Ball screw C_{0a}	Linear guides C_0		
5	$\phi 15$	7 070	25 200	6 550	5	12 800	17 000	2 730	
10		7 070	20 000		10	12 800			
20		4 560	15 900		20	7 730			

Basic static moment load of linear guide

Slider	Basic static moment load (N · m)		
	Rolling M_{RO}	Pitching M_{PO}	Yawing M_{YO}
Double	825	1 220	1 220

MCM08

Accuracy grade: High grade (H)

Ball screw lead 5, 10 and 20

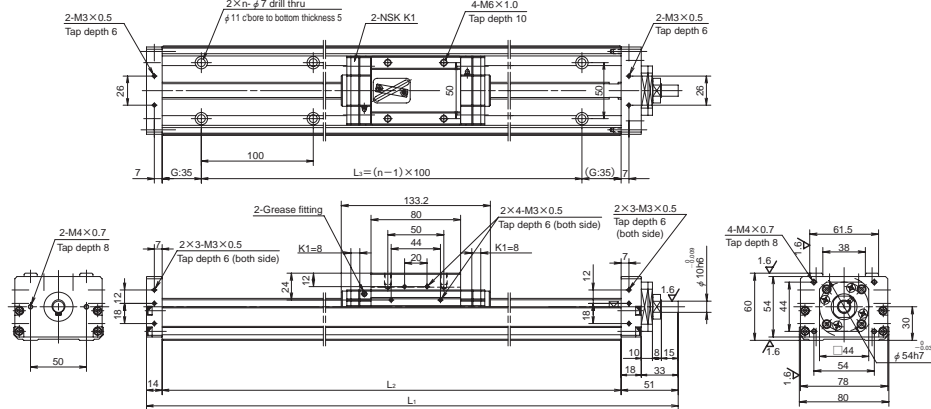

Dimension of MCM08 (Single slider)

Reference No.	Nominal stroke (mm)	Stroke limit (mm) (without K1)	Ball screw lead (mm)	Body length (mm)			No. of mounting hole <i>n</i>	Inertia $\times 10^{-4}$ (kg · m ²)	Mass (kg)
				L ₁	L ₂	L ₃			
◇MCM08005H05K02	50	86 (102)	5	285	220	100	2	0.082	4.1
◇MCM08005H10K00			10						
MCM08010H05K02	100	136 (152)	5	335	270	200	3	0.097	4.6
MCM08010H10K00			10						
MCM08010H20K00			20						
◇MCM08015H05K02			5						
◇MCM08015H10K00	150	186 (202)	10	385	320	200	3	0.111	5.1
◇MCM08015H20K00			20						
MCM08020H05K02			5						
MCM08020H10K00	200	236 (252)	10	435	370	300	4	0.129	5.5
MCM08020H20K00			20						
◇MCM08025H05K02			5						
◇MCM08025H10K00	250	286 (302)	10	485	420	300	4	0.144	6.0
◇MCM08025H20K00			20						
MCM08030H05K02			5						
MCM08030H10K00	300	336 (352)	10	535	470	400	5	0.156	6.5
MCM08030H20K00			20						

Notes: 1. Dimension G is 60 for items marked with ◇.
2. The nominal number in the above table is for high-grade grease specifications. In the case of other specifications, see the following table for the 13th and 14th digits.

Coding for columns 13 and 14

Grease	Lead	High-grade, precision-grade
Standard	5	O2
	10, 20	O0
LG2	5	B2
	10, 20	B0

Monocarrier dynamic torque specification (N · cm)

Ball screw lead (mm)	5		1.0 – 5.9	
	10		2.0 – 7.8	
	20		2.5 – 10.8	
	30		2.8 – 12.0	

Notes:
1. Frictional resistance of NSK K1 is included in dynamic torque in table.
2. Grease is packed into ball screw, linear guide parts and support unit.
3. Consult NSK for life estimates under large moment loads.

Basic load rating

Lead <i>l</i> (mm)	Shaft dia <i>d</i> (mm)	Basic dynamic load rating (N)				Rated running distance <i>L_a</i> (km)	Basic static load rating (N)		Support unit load limit (N)
		Ball screw <i>C_a</i>	Linear guides <i>C</i>	Support unit <i>C_a</i>	Ball screw <i>C_{0a}</i>		Linear guides <i>C₀</i>		
5	φ 15	7 070	30 800	7 100	5	12 800	22 800	3 040	
10		7 070	24 400		10				
20		4 560	19 400		20				
30		5 070	16 930		30				

Basic static moment load of linear guide

Slider	Basic static moment load (N · m)		
	Rolling M _{RO}	Pitching M _{PO}	Yawing M _{YO}
Single	770	300	300

Accuracy grade: High grade (H)

MCM08

Ball screw lead 30

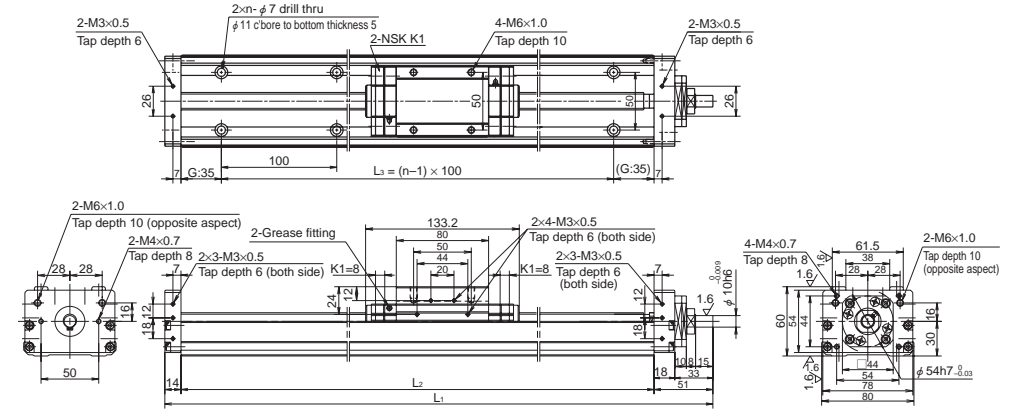

Dimension of MCM08 (Single slider)

Reference No.	Nominal stroke (mm)	Stroke limit (mm) (without K1)	Ball screw lead (mm)	Body length (mm)			No. of mounting hole <i>n</i>	Inertia $\times 10^{-4}$ (kg · m ²)	Mass (kg)
				L ₁	L ₂	L ₃			
MCM08040H05K02	400	436 (452)	5	635	570	500	6	0.185	7.4
MCM08040H10K00			10						
MCM08040H20K00			20						
MCM08040H30K00			30						
MCM08050H05K02	500	536 (552)	5	735	670	600	7	0.214	8.4
MCM08050H10K00			10						
MCM08050H20K00			20						
MCM08050H30K00			30						
MCM08060H05K02	600	636 (652)	5	835	770	700	8	0.232	9.3
MCM08060H10K00			10						
MCM08060H20K00			20						
MCM08060H30K00			30						
MCM08070H05K02	700	736 (752)	5	935	870	800	9	0.244	10.5
MCM08070H10K00			10						
MCM08070H20K00			20						
MCM08070H30K00			30						
MCM08080H05K02	800	836 (852)	5	1 035	970	900	10	0.262	11.2
MCM08080H10K00			10						
MCM08080H20K00			20						

Note: The nominal number in the above table is for high-grade grease specifications. In the case of other specifications, see the following table for the 13th and 14th digits.

Coding for columns 13 and 14

Grease	Lead	High-grade, precision-grade
Standard	5	O2
	10, 20	O0
LG2	5	B2
	10, 20	B0

Monocarrier dynamic torque specification (N · cm)

Ball screw lead (mm)	5		1.0 – 5.9	
	10		2.0 – 7.8	
	20		2.5 – 10.8	
	30		2.8 – 12.0	

Notes:
1. Frictional resistance of NSK K1 is included in dynamic torque in table.
2. Grease is packed into ball screw, linear guide parts and support unit.
3. Consult NSK for life estimates under large moment loads.

Basic load rating

Lead <i>l</i> (mm)	Shaft dia <i>d</i> (mm)	Basic dynamic load rating (N)				Rated running distance <i>L_a</i> (km)	Basic static load rating (N)		Support unit load limit (N)
		Ball screw <i>C_a</i>	Linear guides <i>C</i>	Support unit <i>C_a</i>	Ball screw <i>C_{0a}</i>		Linear guides <i>C₀</i>		
5	φ 15	7 070	30 800	7 100	5	12 800	22 800	3 040	
10		7 070	24 400		10				
20		4 560	19 400		20				
					30				
30		5 070	16 930						

Basic static moment load of linear guide

Slider	Basic static moment load (N · m)		
	Rolling M _{RO}	Pitching M _{PO}	Yawing M _{YO}
Single	770	300	300

MCM08 (Double slider)

Accuracy grade: High grade (H)

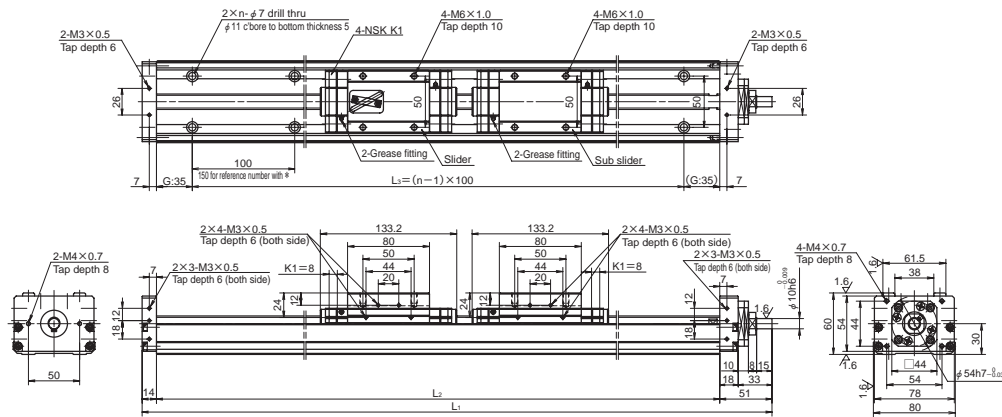

MCM08 (Double slider)

Accuracy grade: High grade (H)

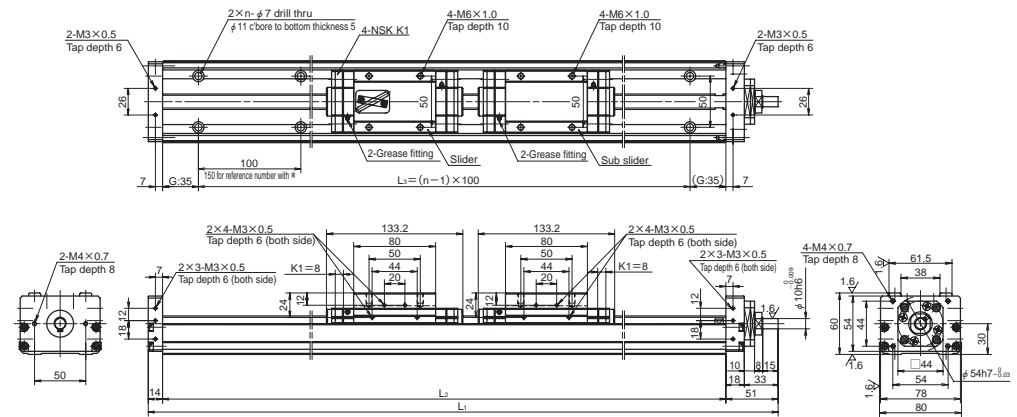

Dimension of MCM08 (Double slider)

Reference No.	Nominal stroke (mm)	Stroke limit (mm) (without K1)	Ball screw lead (mm)	Body length (mm)			No. of mounting hole n	Inertia ×10 ⁻⁴ (kg · m ²)	Mass (kg)
				L ₁	L ₂	L ₃			
*MCM08008H10D00	80	103 (135)	10	435	370	300	3	0.169	6.5
MCM08018H10D00	180	203	10	535	470	400	5	0.199	7.5
MCM08018H20D00		(235)	20					0.351	
MCM08028H10D00	280	303	10	635	570	500	6	0.228	8.4
MCM08028H20D00		(335)	20					0.380	
MCM08038H10D00	380	403	10	735	670	600	7	0.257	9.4
MCM08038H20D00		(435)	20					0.409	

Notes: 1. Bolt hole pitch L3 on item marked with * is 150 mm.
2. The nominal number in the above table is for high-grade grease specifications. In the case of other specifications, see the following table for the 13th and 14th digits.

Coding for columns 13 and 14

Grease	Lead	High-grade, precision-grade
Standard	10, 20	00
LG2	10, 20	B0

Monocarrier dynamic torque specification (N · cm)

Ball screw lead (mm)	10	2.5 – 10.8
	20	4.0 – 17.2

Notes:
1. Frictional resistance of NSK K1 is included in dynamic torque in table.
2. Grease is packed into ball screw, linear guide parts and support unit.
3. Consult NSK for life estimates under large moment loads.

Basic load rating

Lead l (mm)	Shaft dia d (mm)	Basic dynamic load rating (N)				Basic static load rating (N)		Support unit load limit (N)
		Ball screw C _a	Linear guides C	Support unit C _a	Rated running distance L _a (km)	Ball screw C _{0a}	Linear guides C ₀	
10	φ15	7 070	24 400	7 100	10	12 800	22 800	3 040
20		4 560	19 400		20	7 730		

Basic static moment load of linear guide

Slider	Basic static moment load (N · m)		
	Rolling M _{RO}	Pitching M _{PO}	Yawing M _{YO}
Double	1 540	2 050	2 050

Dimension of MCM08 (Double slider)

Reference No.	Nominal stroke (mm)	Stroke limit (mm) (without K1)	Ball screw lead (mm)	Body length (mm)			No. of mounting hole n	Inertia ×10 ⁻⁴ (kg · m ²)	Mass (kg)
				L ₁	L ₂	L ₃			
MCM08048H10D00	480	503	10	835	770	700	8	0.287	10.3
MCM08048H20D00		(535)	20					0.439	
MCM08058H10D00	580	603	10	935	870	800	9	0.316	11.5
MCM08058H20D00		(635)	20					0.468	
MCM08068H10D00	680	703	10	1 035	970	900	10	0.346	12.2
MCM08068H20D00		(735)	20					0.498	

Note: The nominal number in the above table is for high-grade grease specifications. In the case of other specifications, see the following table for the 13th and 14th digits.

Coding for columns 13 and 14

Grease	Lead	High-grade, precision-grade
Standard	10, 20	00
LG2	10, 20	B0

Monocarrier dynamic torque specification (N · cm)

Ball screw lead (mm)	10	2.5 – 10.8
	20	4.0 – 17.2

Notes:
1. Frictional resistance of NSK K1 is included in dynamic torque in table.
2. Grease is packed into ball screw, linear guide parts and support unit.
3. Consult NSK for life estimates under large moment loads.

Basic load rating

Lead l (mm)	Shaft dia d (mm)	Basic dynamic load rating (N)				Basic static load rating (N)		Support unit load limit (N)
		Ball screw C _a	Linear guides C	Support unit C _a	Rated running distance L _a (km)	Ball screw C _{0a}	Linear guides C ₀	
10	φ15	7 070	24 400	7 100	10	12 800	22 800	3 040
20		4 560	19 400		20	7 730		

Basic static moment load of linear guide

Slider	Basic static moment load (N · m)		
	Rolling M _{RO}	Pitching M _{PO}	Yawing M _{YO}
Double	1 540	2 050	2 050

MCM10 (Double slider)

Accuracy grade: High grade (H)

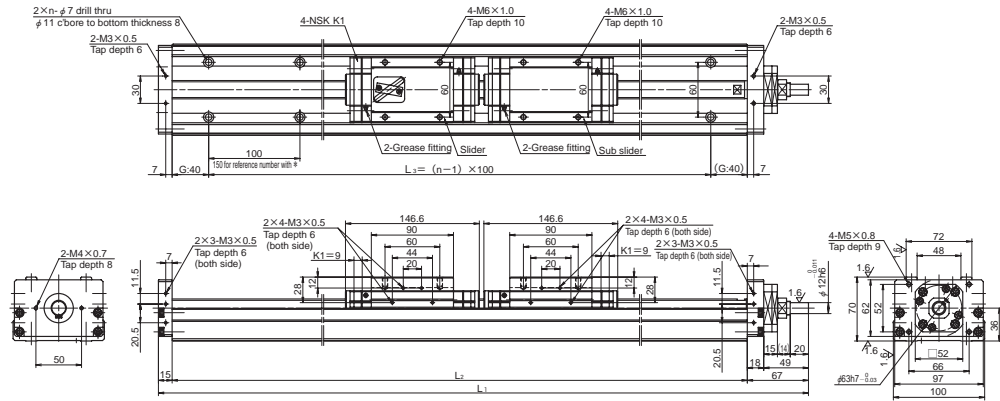

MCM10 (Double slider)

Accuracy grade: High grade (H)

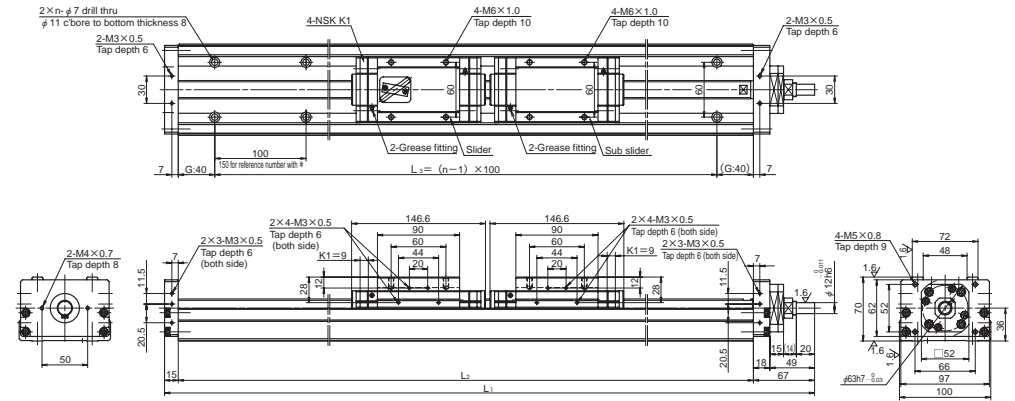

Dimension of MCM10 (Double slider)

Reference No.	Nominal stroke (mm)	Stroke limit (mm) (without K1)	Ball screw lead (mm)	Body length (mm)			No. of mounting hole n	Inertia $\times 10^{-4}$ (kg · m ²)	Mass (kg)
				L_1	L_2	L_3			
*MCM10007H10D00	70	86 (122)	10	462	380	300	3	0.463	11.0
MCM10017H10D00	170	186 (222)	10	562	480	400	5	0.557	
MCM10017H20D00		20	0.785						
MCM10027H10D00	270	286 (322)	10	662	580	500	6	0.650	13.4
MCM10027H20D00		20	0.878						
MCM10037H10D00	370	386 (422)	10	762	680	600	7	0.744	15.1
MCM10037H20D00		20	0.972						
MCM10047H10D00	470	486 (522)	10	862	780	700	8	0.838	17.8
MCM10047H20D00		20	1.066						

Note: Bolt hole pitch L_3 on item marked with * is 150 mm.

Dimension of MCM10 (Double slider)

Reference No.	Nominal stroke (mm)	Stroke limit (mm) (without K1)	Ball screw lead (mm)	Body length (mm)			No. of mounting hole n	Inertia $\times 10^{-4}$ (kg · m ²)	Mass (kg)
				L_1	L_2	L_3			
MCM10057H10D00	570	586 (622)	10	962	880	800	9	0.931	19.5
MCM10057H20D00			20					1.159	
MCM10067H10D00	670	686 (722)	10	1 062	980	900	10	1.025	21.2
MCM10067H20D00			20					1.253	
◇MCM10087H10D00	870	886 (922)	10	1 262	1 180	1 000	11	1.212	23.6
◇MCM10087H20D00			20					1.440	

Note: Dimension G is 90 for items marked with ◇.

Monocarrier dynamic torque specification (N · cm)

Ball screw lead (mm)	10	4.2 – 15.6
	20	5.0 – 19.6

Notes:

1. Frictional resistance of NSK K1 is included in dynamic torque in table.
2. Grease is packed into ball screw, linear guide parts and support unit.
3. Consult NSK for life estimates under large moment loads.

Monocarrier dynamic torque specification (N · cm)

Ball screw lead (mm)	10	4.2 – 15.6
	20	5.0 – 19.6

Notes:

1. Frictional resistance of NSK K1 is included in dynamic torque in table.
2. Grease is packed into ball screw, linear guide parts and support unit.
3. Consult NSK for life estimates under large moment loads.

Basic load rating

Lead l (mm)	Shaft dia d (mm)	Basic dynamic load rating (N)				Basic static load rating (N)			Support unit load limit (N)
		Ball screw C_a	Linear guides C	Support unit C_a	Rated running distance L_a (km)	Ball screw C_{0a}	Linear guides C_0		
10	$\phi 20$	11 000	33 500	7 600	10	21 100	29 400	3 380	
20		7 060	26 600		20	12 700			

Basic static moment load of linear guide

Slider	Basic static moment load (N · m)		
	Rolling M_{RO}	Pitching M_{PO}	Yawing M_{YO}
Double	2 340	2 940	2 940

Basic load rating

Lead l (mm)	Shaft dia d (mm)	Basic dynamic load rating (N)				Basic static load rating (N)			Support unit load limit (N)
		Ball screw C_a	Linear guides C	Support unit C_a	Rated running distance L_a (km)	Ball screw C_{0a}	Linear guides C_0		
10	$\phi 20$	11 000	33 500	7 600	10	21 100	29 400	3 380	
20		7 060	26 600		20	12 700			

Basic static moment load of linear guide

Slider	Basic static moment load (N · m)		
	Rolling M_{RO}	Pitching M_{PO}	Yawing M_{YO}
Double	2 340	2 940	2 940

C-1-5.3 MCM Series Accessories

C-1-5. 3. 1 Sensor Unit

● Proximity switch

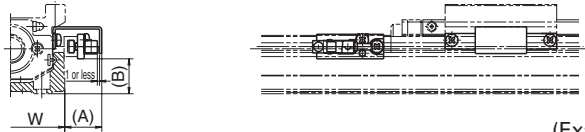

(Example of assembly)

Model No.	Reference No.			A (mm)	B (mm)	Body width W (mm)
MCM02	MC-SR02-00	MC-SR02-01	MC-SR02-02	17	2	28
MCM03	MC-SR03-10	MC-SR03-11	MC-SR03-12	17	3	34
MCM05	MC-SR05-10	MC-SR05-11	MC-SR05-12	17	15	48.6
MCM06	MC-SR06-10	MC-SR06-11	MC-SR06-12	17	19	58
MCM08	MC-SR08-10	MC-SR08-11	MC-SR08-12	16	27	80
MCM10	MC-SR10-10	MC-SR10-11	MC-SR10-12	16	35	100
Quantity	Proximity switch (normally open contact)	—	3	1	E2S-W13 (OMRON Corp.)	
	Proximity switch (normally close contact)	3	—	2	E2S-W14 (OMRON Corp.)	

Notes: 1. See page C135 for proximity switch specification.
 2. A sensor unit consists of sensors, a sensor dog and sensor mounting parts.
 3. Sensor unit for MCM02 contains two sensor dogs.
 4. A spacer plate is required when using a cover unit or sensor unit for MCM03 with the lead of 1 or 2 mm. (Refer to page C51.)

● Photo sensor

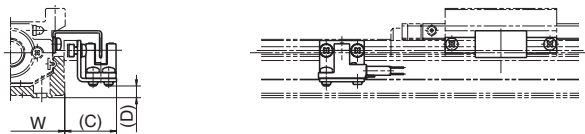

(Example of assembly)

Model No.	Reference No.	C (mm)	D (mm)	Body width W (mm)	Remarks
MCM03	MC-SR03-13	24	0.5	34	EE-SX674 (OMRON Corp.) 3 sets (EE-1001 connector attachment)
MCM05	MC-SR05-13	24	5	48.6	
MCM06	MC-SR06-13	24	9	58	
MCM08	MC-SR08-13	23	17	80	
MCM10	MC-SR10-13	22	24	100	

Notes: 1. See page C136 for photo sensor specification.
 2. A sensor unit consists of sensors, a sensor dog and sensor mounting parts.
 3. A spacer plate is required when using a cover unit or sensor unit for MCM03 with the lead of 1 or 2 mm. (Refer to page C51.)

(1) Sensor Rail

Sensor rail for MCM03: MC-SRL3- * * * *

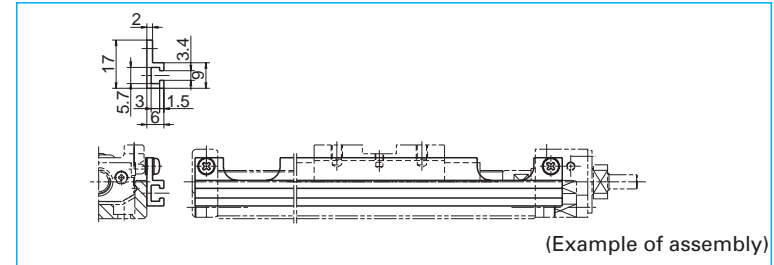

(Example of assembly)

Sensor rail for MCM05: MC-SRL5- * * * *

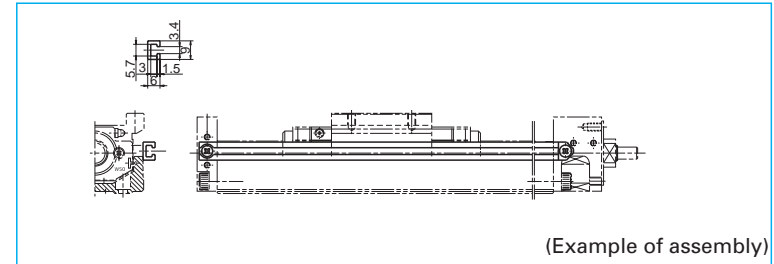

(Example of assembly)

Sensor rail for MCM02: MC-SRL2- * * * *

Sensor rail for MCM06: MC-SRL6- * * * *

Sensor rail for MCM08: MC-SRL8- * * * *

Sensor rail for MCM10: MC-SRL1- * * * *

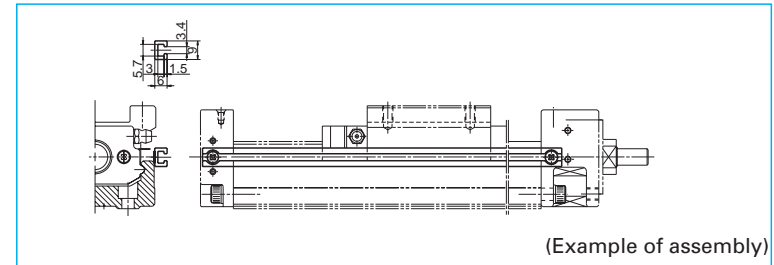

(Example of assembly)

Notes: 1. * * * * is the same as rail dimension L₂.
 2. Please assemble the attached seat between the sensor rail and the support unit for MCM03, MCM05, MCM06 and MCM08.
 3. For combinations of sensors and rails, see pages C49 to C50.

MCM Series and Sensor Rail Combination Table

Table 4

Model No.	Body length L ₂ (mm)	Reference No.	Sensor rail reference No.
MCM02	100	MCM02005H01K MCM02005P01K MCM02005H02K MCM02005P02K	MC-SRL2-0100 [※]
		MCM02010H01K MCM02010P01K MCM02010H02K MCM02010P02K	MC-SRL2-0150
		MCM02015H01K MCM02015P01K MCM02015H02K MCM02015P02K	MC-SRL2-0200
MCM03	115	MCM03005P01K00 MCM03005P02K00	MC-SRL3-0115
		MCM03005H05K00 MCM03005H10K00 MCM03005H12K00 MCM03005H15K00	MC-SRL3-0140
		MCM03010P01K00 MCM03010P02K00 MCM03010H05K00 MCM03010H10K00 MCM03010H12K00 MCM03010H15K00	MC-SRL3-0190
MCM03	140	MCM03015P01K00 MCM03015P02K00 MCM03015H05K00 MCM03015H10K00 MCM03015H12K00 MCM03015H15K00	MC-SRL3-0240
		MCM03020H05K00 MCM03020H10K00 MCM03020H12K00 MCM03020H15K00	MC-SRL3-0290
		MCM03025H05K00 MCM03025H10K00 MCM03025H12K00 MCM03025H15K00	MC-SRL3-0340
MCM05	180	MCM05005H05K00 MCM05005H10K00 MCM05005H20K00	MC-SRL5-0180
		MCM05010H05K00 MCM05010H10K00 MCM05010H20K00	MC-SRL5-0230
		MCM05015H05K00 MCM05015H10K00 MCM05015H20K00 MCM05006H10D00	MC-SRL5-0280
MCM05	230	MCM05020H05K00 MCM05020H10K00 MCM05020H20K00 MCM05011H10D00	MC-SRL5-0330
		MCM05025H05K00 MCM05025H10K00 MCM05025H20K00 MCM05016H10D00	MC-SRL5-0380
		MCM05030H05K00 MCM05030H10K00 MCM05030H20K00 MCM05030H30K00 MCM05021H10D00 MCM05021H20D00	MC-SRL5-0430
MCM05	330	MCM05040H05K00 MCM05040H10K00 MCM05040H20K00 MCM05031H10D00	MC-SRL5-0530

Model No.	Body length L ₂ (mm)	Reference No.	Sensor rail reference No.
MCM05	530	MCM05031H20D00	MC-SRL5-0530
		MCM05050H05K00 MCM05050H10K00 MCM05050H20K00 MCM05050H30K00 MCM05041H10D00 MCM05041H20D00	MC-SRL5-0630
		MCM05060H05K00 MCM05060H10K00 MCM05060H20K00 MCM05060H30K00 MCM05051H10D00 MCM05051H20D00	MC-SRL5-0730
MCM06	190	MCM06005H05K02 MCM06005H10K00 MCM06005H20K00	MC-SRL6-0190
		MCM06010H05K02 MCM06010H10K00 MCM06010H20K00	MC-SRL6-0240
		MCM06015H05K02 MCM06015H10K00 MCM06015H20K00	MC-SRL6-0290
MCM06	240	MCM06020H05K02 MCM06020H10K00 MCM06020H20K00 MCM06011H05D02 MCM06011H10D00	MC-SRL6-0340
		MCM06025H05K02 MCM06025H10K00 MCM06025H20K00	MC-SRL6-0390
		MCM06030H05K02 MCM06030H10K00 MCM06030H20K00 MCM06021H05D02 MCM06021H10D00 MCM06021H20D00	MC-SRL6-0440
MCM06	340	MCM06040H05K02 MCM06040H10K00 MCM06040H20K00 MCM06031H05D02 MCM06031H10D00 MCM06031H20D00	MC-SRL6-0540
		MCM06050H05K02 MCM06050H10K00 MCM06050H20K00 MCM06041H05D02 MCM06041H10D00 MCM06041H20D00	MC-SRL6-0640
		MCM06060H05K02 MCM06060H10K00 MCM06060H20K00 MCM06051H10D00 MCM06051H20D00	MC-SRL6-0740
MCM06	440	MCM06070H05K02 MCM06070H10K00 MCM06070H20K00 MCM06061H10D00 MCM06061H20D00	MC-SRL6-0840
		MCM06080H05K02 MCM06080H10K00 MCM06080H20K00 MCM06071H10D00 MCM06071H20D00	MC-SRL6-0940

*) When using NSK standard sensors, prepare two sensor rails. Two sensor rails will also be required for another Monocarriers depending on signal points of sensors. Contact NSK for details.

Model No.	Body length L ₂ (mm)	Reference No.	Sensor rail reference No.
MCM08	220	MCM08005H05K02 MCM08005H10K00	MC-SRL8-0220
		MCM08010H05K02 MCM08010H10K00 MCM08010H20K00	MC-SRL8-0270
		MCM08015H05K02 MCM08015H10K00 MCM08015H20K00	MC-SRL8-0320
MCM08	270	MCM08020H05K02 MCM08020H10K00 MCM08020H20K00	MC-SRL8-0370
		MCM08025H05K02 MCM08025H10K00 MCM08025H20K00	MC-SRL8-0420
		MCM08030H05K02 MCM08030H10K00 MCM08030H20K00 MCM08018H10D00 MCM08018H20D00	MC-SRL8-0470
MCM08	320	MCM08040H05K02 MCM08040H10K00 MCM08040H20K00 MCM08028H10D00 MCM08028H20D00	MC-SRL8-0570
		MCM08050H05K02 MCM08050H10K00 MCM08050H20K00 MCM08050H30K00 MCM08038H10D00 MCM08038H20D00	MC-SRL8-0670
		MCM08060H05K02 MCM08060H10K00 MCM08060H20K00 MCM08060H30K00 MCM08048H10D00 MCM08048H20D00	MC-SRL8-0770
MCM08	370	MCM08070H05K02 MCM08070H10K00 MCM08070H20K00 MCM08070H30K00 MCM08058H10D00 MCM08058H20D00	MC-SRL8-0870
		MCM08080H05K02 MCM08080H10K00 MCM08080H20K00 MCM08080H30K00 MCM08068H10D00 MCM08068H20D00	MC-SRL8-0970

Model No.	Body length L ₂ (mm)	Reference No.	Sensor rail reference No.
MCM10	280	MCM10010H10K00 MCM10010H20K00	MC-SRL1-0280
		MCM10015H10K00 MCM10015H20K00	MC-SRL1-0330
		MCM10020H10K00 MCM10020H20K00 MCM10007H10K00	MC-SRL1-0380
MCM10	330	MCM10025H10K00 MCM10025H20K00	MC-SRL1-0430
		MCM10030H10K00 MCM10030H20K00 MCM10017H10K00 MCM10017H20K00	MC-SRL1-0480
		MCM10040H10K00 MCM10040H20K00 MCM10027H10K00 MCM10027H20K00	MC-SRL1-0580
MCM10	380	MCM10050H10K00 MCM10050H20K00 MCM10037H10K00 MCM10037H20K00	MC-SRL1-0680
		MCM10060H10K00 MCM10060H20K00 MCM10060H30K00 MCM10047H10K00 MCM10047H20K00	MC-SRL1-0780
		MCM10070H10K00 MCM10070H20K00 MCM10070H30K00 MCM10057H10K00 MCM10057H20K00	MC-SRL1-0880
MCM10	430	MCM10080H10K00 MCM10080H20K00 MCM10080H30K00 MCM10067H10K00 MCM10067H20K00	MC-SRL1-0980
		MCM10090H10K00 MCM10090H20K00	MC-SRL1-1080
		MCM10100H10K00 MCM10100H20K00 MCM10087H10K00 MCM10087H20K00	MC-SRL1-1180

C-1-5. 3. 2 Cover Unit

Cover Unit for MCM02

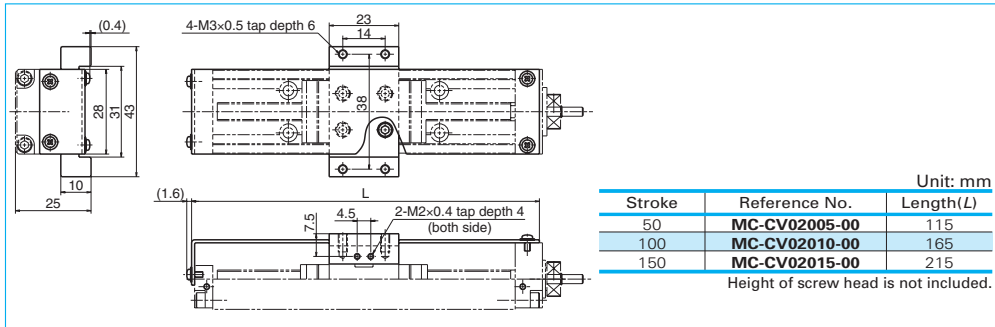

Cover Unit for MCM03

Notes: 1. When the cover is used for leads 1 and 2, an optional spacer plate (nominal No.: MC-SP03-00) is required.
 2. When the cover is used for lead 15, an optional spacer plate (nominal No.: MC-SP03-01) is required. A full cover unit cannot be installed for lead 15.

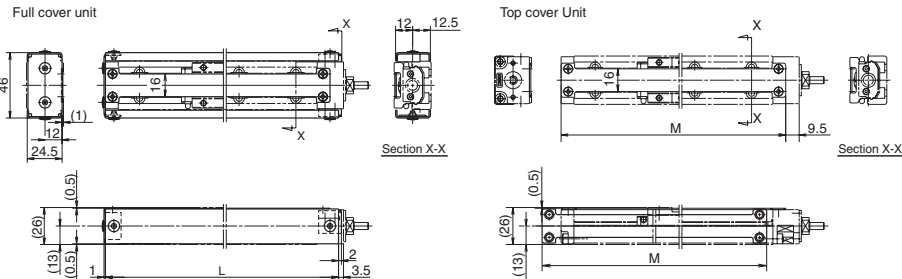

Stroke	Reference No.		Cover length	
	Top cover unit	Full cover unit	Length (L)	Length (M)
50 (lead 1, 2)	MC-CV03005-02	*MC-CV03005-01	139	133
50 (lead 5, 10, 12, 15)	MC-CV03005-02A	*MC-CV03005-01A	164	158
100	MC-CV03010-02	*MC-CV03010-01	214	208
150	MC-CV03015-02	*MC-CV03015-01	264	258
200	MC-CV03020-02	*MC-CV03020-01	314	308
250	MC-CV03025-02	*MC-CV03025-01	364	358

*1) The full-cover unit cannot be used when the sensor unit is used. Height of screw head is not included.

Spacer for MCM03 (Optional)

MC-SP03-00 (for ball screw lead 1 and 2 mm)

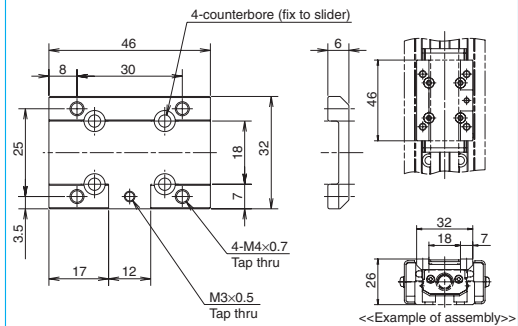

MC-SP03-01 (for ball screw lead 15 mm)

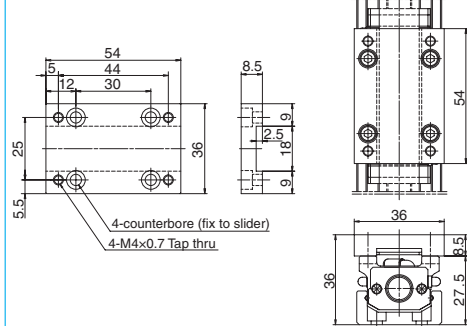

Cover unit for MCM05, 06, 08, and 10

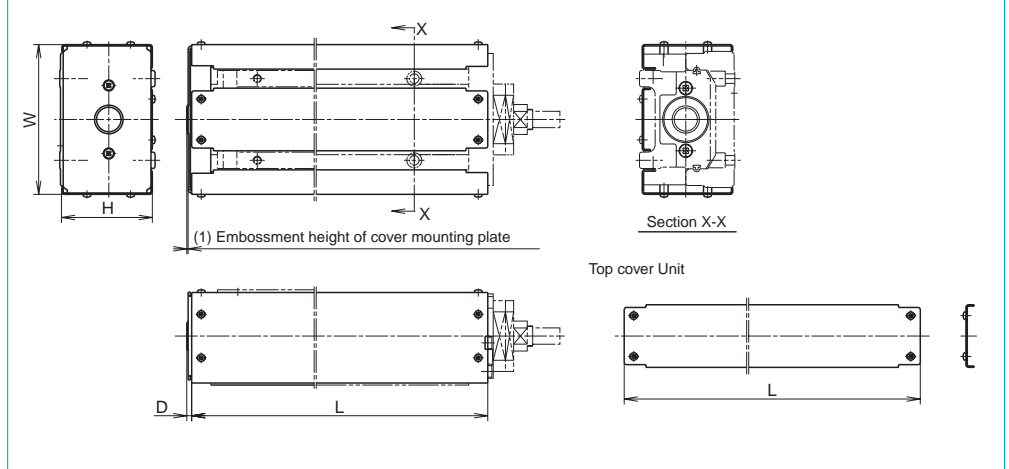

Model No.	Stroke		Cover unit reference No.		Cover length			
	Single slider	Double slider	Top cover Unit	Full cover Unit*1	Length (L)	Height (H)	Width (W)	End part (D)
	MCM05	50 100 150 200 250 300 400 500 600	— — 60 110 160 210 310 410 510	MC-CV05005-01 MC-CV05010-01 MC-CV05015-01 MC-CV05020-01 MC-CV05025-01 MC-CV05030-01 MC-CV05040-01 MC-CV05050-01 MC-CV05060-01	MC-CV05005-00 MC-CV05010-00 MC-CV05015-00 MC-CV05020-00 MC-CV05025-00 MC-CV05030-00 MC-CV05040-00 MC-CV05050-00 MC-CV05060-00	200 250 300 350 400 450 550 650 750	38.5	65
MCM06	100 150 200 250 300 400 500 600 700 800	— — 110 — 210 310 410 510 610 710	MC-CV06005-01 MC-CV06010-01 MC-CV06015-01 MC-CV06020-01 MC-CV06025-01 MC-CV06030-01 MC-CV06040-01 MC-CV06050-01 MC-CV06060-01 MC-CV06070-01 MC-CV06080-01	MC-CV06005-00 MC-CV06010-00 MC-CV06015-00 MC-CV06020-00 MC-CV06025-00 MC-CV06030-00 MC-CV06040-00 MC-CV06050-00 MC-CV06060-00 MC-CV06070-00 MC-CV06080-00	225 275 325 375 425 475 575 675 775 875 975	48.5	75	*2
MCM08	100 150 200 250 300 400 500 600 700 800	— — 80 — 180 280 380 480 580 680	MC-CV08005-01 MC-CV08010-01 MC-CV08015-01 MC-CV08020-01 MC-CV08025-01 MC-CV08030-01 MC-CV08040-01 MC-CV08050-01 MC-CV08060-01 MC-CV08070-01 MC-CV08080-01	MC-CV08005-00 MC-CV08010-00 MC-CV08015-00 MC-CV08020-00 MC-CV08025-00 MC-CV08030-00 MC-CV08040-00 MC-CV08050-00 MC-CV08060-00 MC-CV08070-00 MC-CV08080-00	248 298 348 398 448 498 598 698 798 898 998	56.5	90	2.6
MCM10	100 150 200 250 300 400 500 600 700 800 900 1000	— — 70 — 170 270 370 470 570 670 — 870	MC-CV10010-01 MC-CV10015-01 MC-CV10020-01 MC-CV10025-01 MC-CV10030-01 MC-CV10040-01 MC-CV10050-01 MC-CV10060-01 MC-CV10070-01 MC-CV10080-01 MC-CV10090-01 MC-CV10100-01	MC-CV10010-00 MC-CV10015-00 MC-CV10020-00 MC-CV10025-00 MC-CV10030-00 MC-CV10040-00 MC-CV10050-00 MC-CV10060-00 MC-CV10070-00 MC-CV10080-00 MC-CV10090-00 MC-CV10100-00	308 358 408 458 508 608 708 808 908 1008 1108 1208	66.5	110	3.6

Note: The dimensions of cover shown above do not include the head height of fixing machine screws. Add the head of machine screws of approximately 2.5 mm to the outer measurement of a cover unit. Set a margin for mechanical interference with surrounding components.

*1) When using sensor unit, full-cover unit cannot be used.
 *2) A cover mounting plate is not used to MCM06.

C-1-5. 3.3 Motor Bracket

Motor models are subject to change at the motor manufacturers. For details, please contact the manufacturer.

Motor bracket for MCM02

Reference number
MC-BK02-128-00

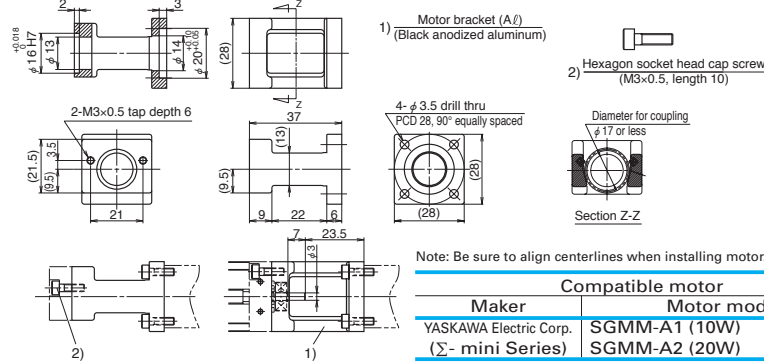

Reference number
MC-BK02-133-00

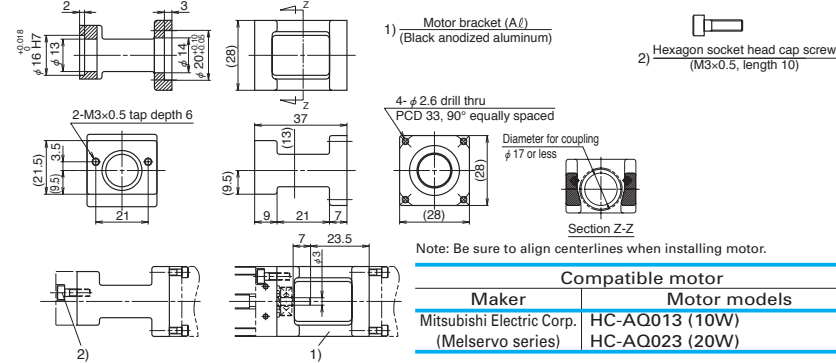

Reference number
MC-BK02-223-00

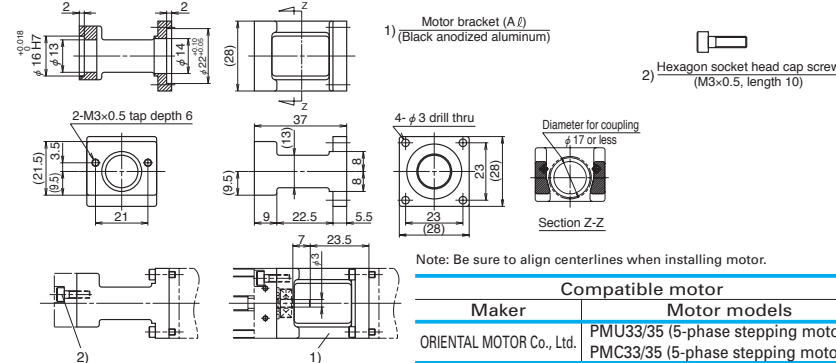

Motor bracket for MCM03

Reference number
MC-BK03-146-00

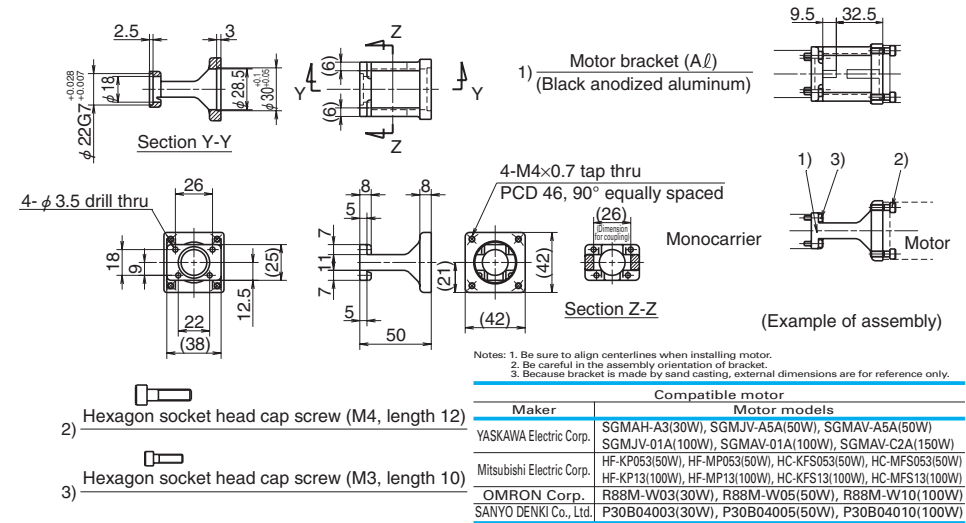

Motor bracket for MCM03

Reference number
MC-BK03-148-01

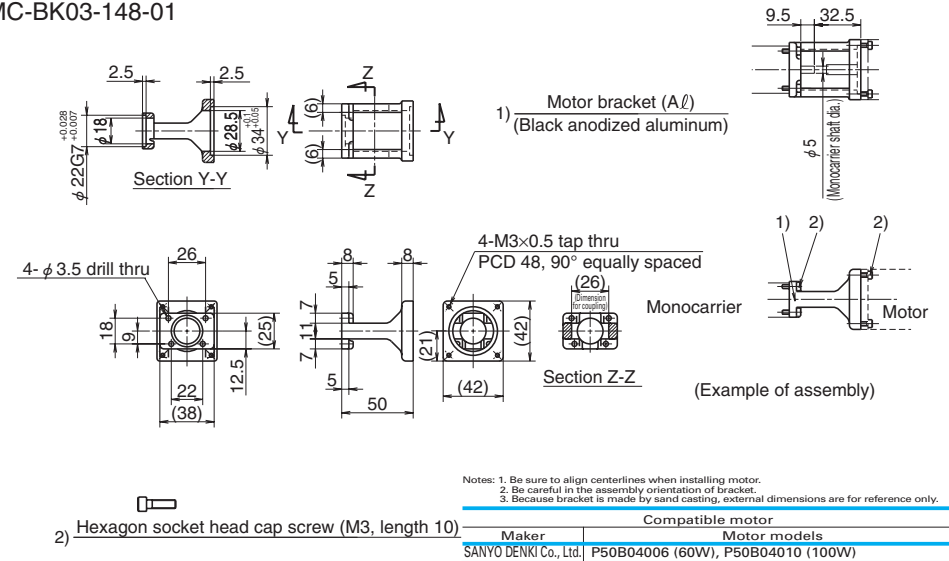

Motor bracket for MCM05

Reference number
MC-BK05-160-00

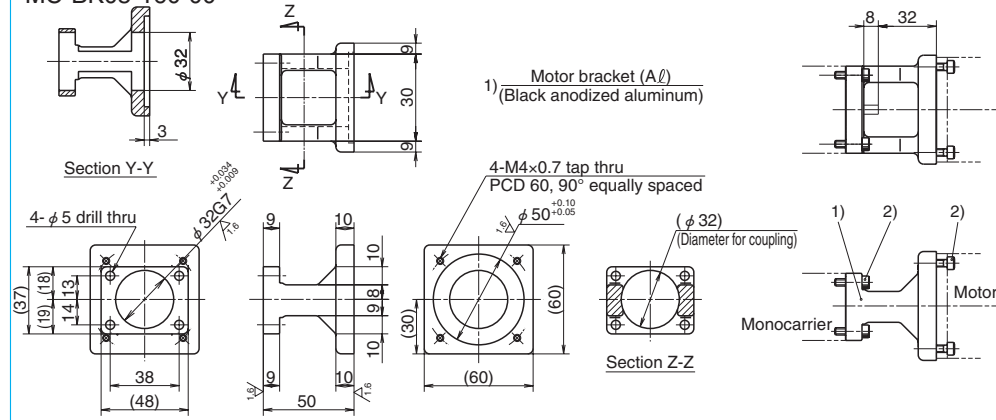

Notes: 1. Be sure to align centerlines when installing motor.
2. Be careful in the assembly orientation of bracket.
3. Because bracket is made by sand casting, external dimensions are for reference only.

Compatible motor	
Maker	Motor models
SANYO DENKI Co., Ltd.	P50B05005(50W), P50B05010(100W), P50B05020(200W)

- 2) Hexagon socket head cap screw (M4, length 15)

Motor bracket for MCM06

Reference number
MC-BK06-145-00

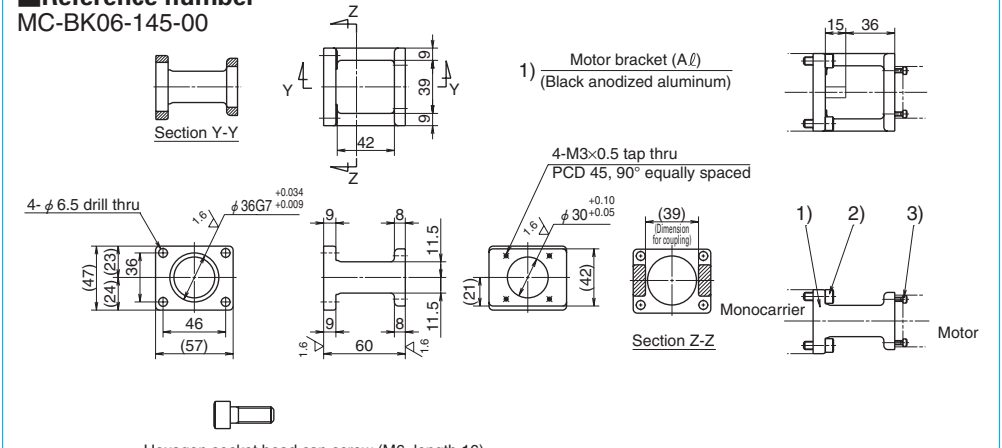

Notes: 1. Be sure to align centerlines when installing motor.
2. Be careful in the assembly orientation of bracket.
3. Because bracket is made by sand casting, external dimensions are for reference only.

Compatible motor	
Maker	Motor models
Panasonic Co., Ltd.	MSMD5A(50W), MSMD01(100W)

- 2) Hexagon socket head cap screw (M6, length 16)
3) Hexagon socket head cap screw (M3, length 12)

Motor bracket for MCM05

Reference number
MC-BK05-250-00

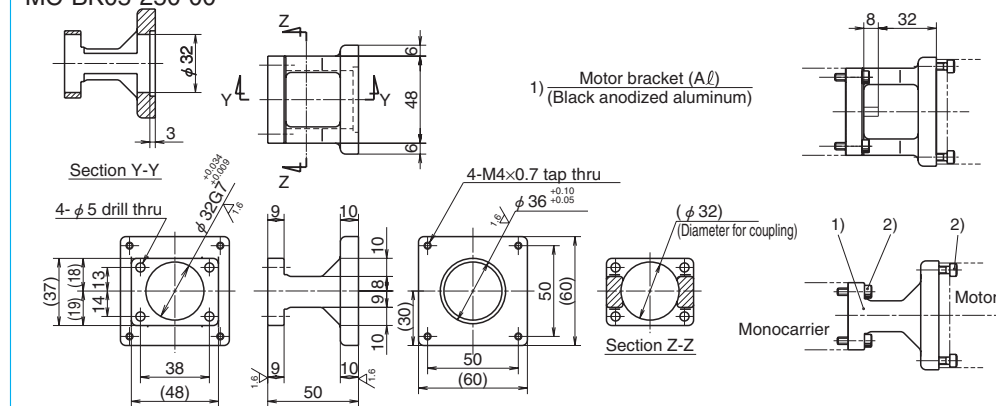

Notes: 1. Be sure to align centerlines when installing motor.
2. Be careful in the assembly orientation of bracket.
3. Because bracket is made by sand casting, external dimensions are for reference only.

Compatible motor	
Maker	Motor models
SANYO DENKI Co., Ltd.	PBM603xxx, PBM604xxx, 103F78xx
ORIENTAL MOTOR Co., Ltd.	AS66, ASC66, UPK56x, UFK56x, PK56x, CSK56x, CFK56x

- 2) Hexagon socket head cap screw (M4, length 15)

Motor bracket for MCM06

Reference number
MC-BK06-146-00

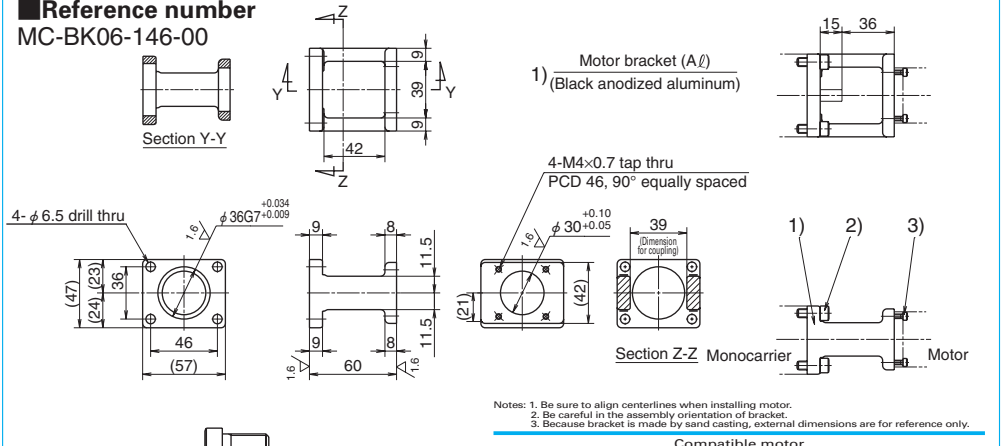

Notes: 1. Be sure to align centerlines when installing motor.
2. Be careful in the assembly orientation of bracket.
3. Because bracket is made by sand casting, external dimensions are for reference only.

Compatible motor	
Maker	Motor models
YASKAWA Electric Corp.	SGMJV-A5A(50W), SGMJV-A5A(50W), SGMJV-01A(100W), SGMJV-01A(100W), SGMJV-C2A(150W)
Mitsubishi Electric Corp.	HF-KP05(50W), HF-MP05(50W), HC-KFS05(50W), HC-MFS05(50W), HF-KP13(100W), HF-MP13(100W), HC-KFS13(100W), HC-MFS13(100W)
OMRON Corp.	R88M-W03(30W), R88M-W05(50W), R88M-W10(100W)
SANYO DENKI Co., Ltd.	P30B04003(30W), P30B04005(50W), P30B04010(100W)

- 2) Hexagon socket head cap screw (M6, length 16)
3) Hexagon socket head cap screw (M4, length 12)

Motor bracket for MCM06

Reference number
MC-BK06-148-00

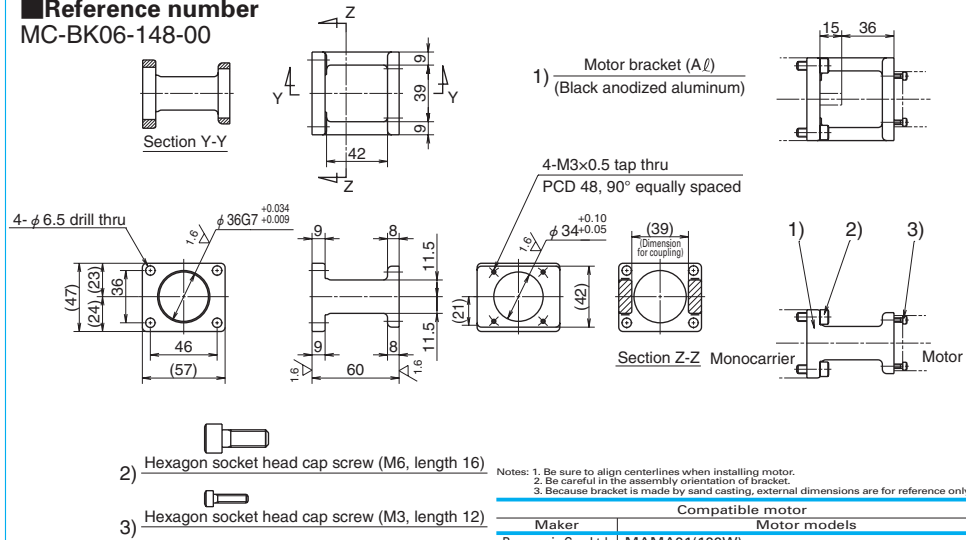

Notes: 1. Be sure to align centerlines when installing motor.
2. Be careful in the assembly orientation of bracket.
3. Because bracket is made by sand casting, external dimensions are for reference only.

Compatible motor	
Maker	Motor models
Panasonic Co., Ltd.	MAMA01(100W)
SANYO DENKI Co., Ltd.	P50B04006(60W), P50B04010(100W)

Motor bracket for MCM06

Reference number
MC-BK06-170-00

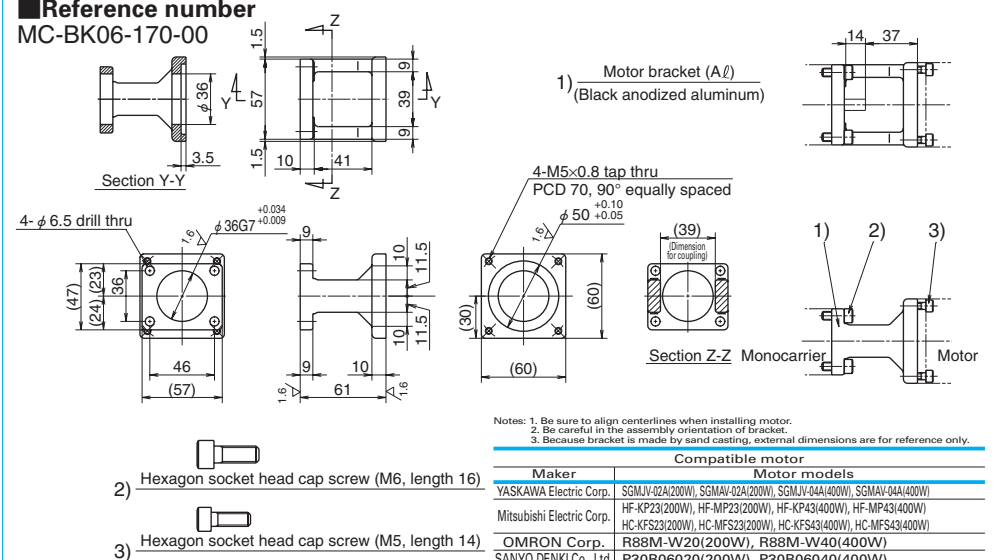

Notes: 1. Be sure to align centerlines when installing motor.
2. Be careful in the assembly orientation of bracket.
3. Because bracket is made by sand casting, external dimensions are for reference only.

Compatible motor	
Maker	Motor models
YASKAWA Electric Corp.	SGMJV-02A(200W), SGMJV-02A(200W), SGMJV-04A(400W), SGMJV-04A(400W)
Mitsubishi Electric Corp.	HF-KP23(200W), HF-MP23(200W), HF-KP43(400W), HF-MP43(400W), HC-KFS23(200W), HC-MFS23(200W), HC-KFS43(400W), HC-MFS43(400W)
OMRON Corp.	R88M-W20(200W), R88M-VV40(400W)
SANYO DENKI Co., Ltd.	P30B06020(200W), P30B06040(400W)

Motor bracket for MCM06

Reference number
MC-BK06-160-00

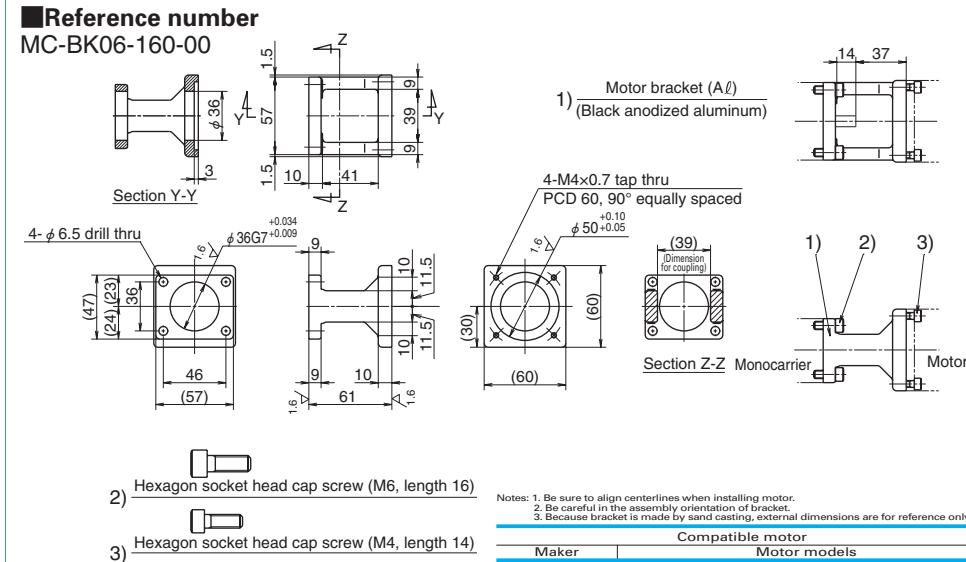

Notes: 1. Be sure to align centerlines when installing motor.
2. Be careful in the assembly orientation of bracket.
3. Because bracket is made by sand casting, external dimensions are for reference only.

Compatible motor	
Maker	Motor models
SANYO DENKI Co., Ltd.	P50B05005(50W), P50B05010(100W), P50B05020(200W)

Motor bracket for MCM06

Reference number
MC-BK06-170-01

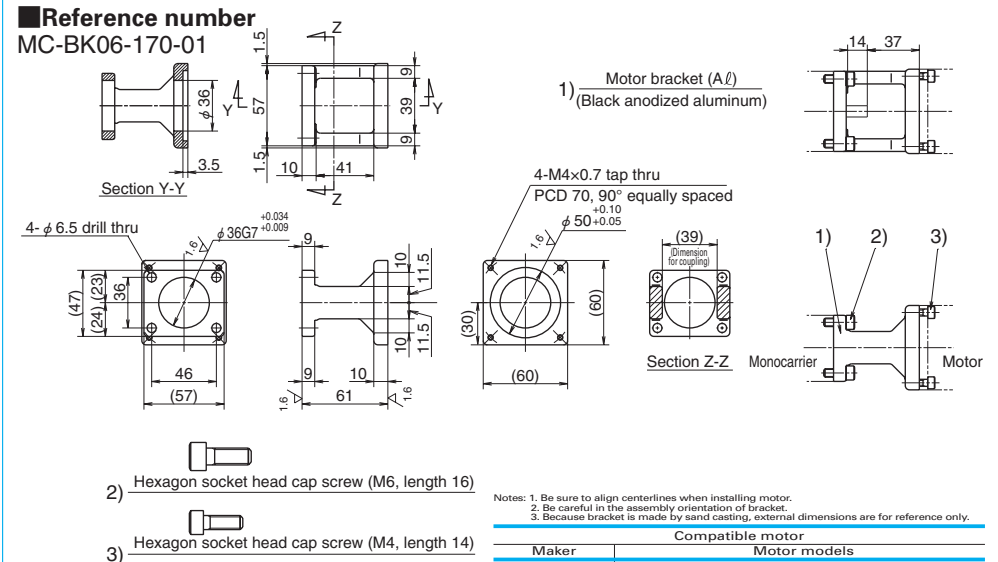

Notes: 1. Be sure to align centerlines when installing motor.
2. Be careful in the assembly orientation of bracket.
3. Because bracket is made by sand casting, external dimensions are for reference only.

Compatible motor	
Maker	Motor models
Panasonic Co., Ltd.	MSMD02(200W), MAMA02(200W), MSM04(400W), MAMA04(400W)

Motor bracket for MCM08

Reference number
MC-BK08-170-00

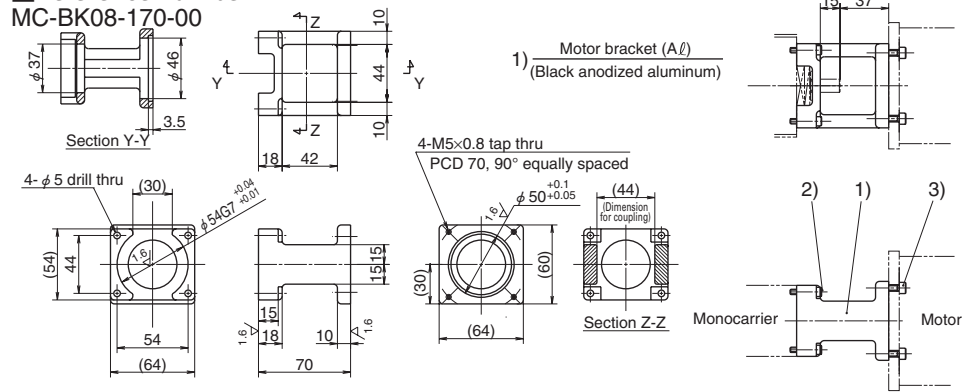

Notes: 1. Be sure to align centerlines when installing motor.
2. Be careful in the assembly orientation of bracket.
3. Because bracket is made by sand casting, external dimensions are for reference only.

Compatible motor	
Maker	Motor models
YASKAWA Electric Corp.	SGMJV-02A(200W), SGMJV-02A(200W), SGMJV-04A(400W), SGMJV-04A(400W)
Mitsubishi Electric Corp.	HF-KP23(200W), HF-MP23(200W), HF-KP43(400W), HF-MP43(400W) HC-KFS23(200W), HC-MFS23(200W), HC-KFS43(400W), HC-MFS43(400W)
OMRON Corp.	R88M-W20(200W), R88M-W40(400W)
SANYO DENKI Co., Ltd.	P30B06020(200W), P30B06040(400W)

- Hexagon socket head cap screw (M4, length 20)
- Hexagon socket head cap screw (M5, length 14)

Motor bracket for MCM08

Reference number
MC-BK08-250-00

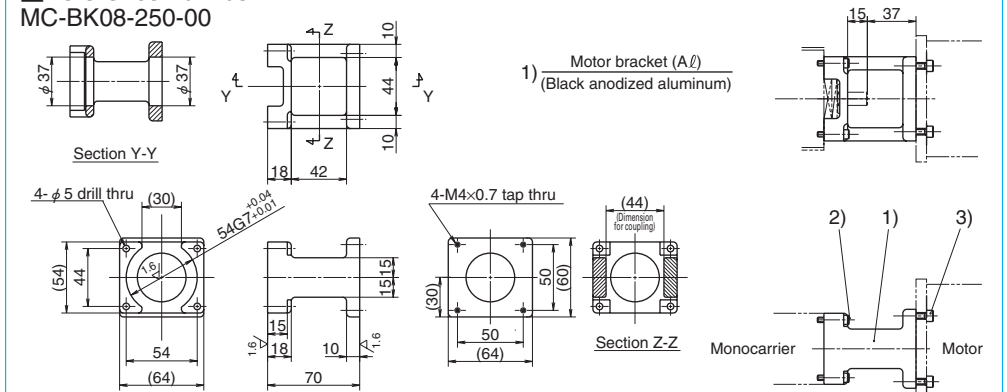

Notes: 1. Be sure to align centerlines when installing motor.
2. Be careful in the assembly orientation of bracket.
3. Because bracket is made by sand casting, external dimensions are for reference only.

Compatible motor	
Maker	Motor models
SANYO DENKI Co., Ltd.	PBM603xxx, PBM604xxx, 103F78xx
ORIENTAL MOTOR Co., Ltd.	AS66, ASC66, UPK56xx, PK56xx, CSK56x CFK56x, UFK56x

- Hexagon socket head cap screw (M4, length 20)
- Hexagon socket head cap screw (M4, length 14)

Motor bracket for MCM08

Reference number
MC-BK08-170-01

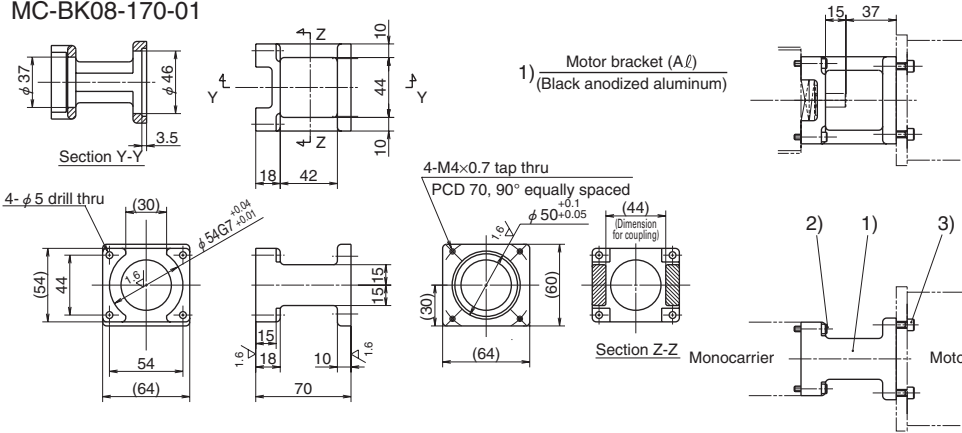

Notes: 1. Be sure to align centerlines when installing motor.
2. Be careful in the assembly orientation of bracket.
3. Because bracket is made by sand casting, external dimensions are for reference only.

Compatible motor	
Maker	Motor models
Panasonic Co., Ltd.	MSMD02(200W), MAMA02(200W), MSMD04(400W), MAMA04(400W)

- Hexagon socket head cap screw (M4, length 20)
- Hexagon socket head cap screw (M4, length 14)

Motor bracket for MCM08

Reference number
MC-BK08-190-00

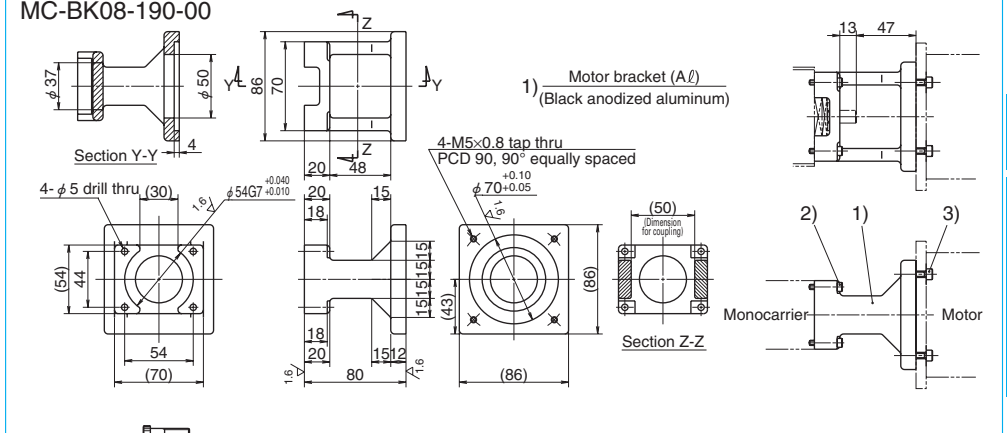

Notes: 1. Be sure to align centerlines when installing motor.
2. Be careful in the assembly orientation of bracket.
3. Because bracket is made by sand casting, external dimensions are for reference only.

Compatible motor	
Maker	Motor models
SANYO DENKI Co., Ltd.	P50B07020(200W), P50B07030(300W), P50B07040(400W)

- Hexagon socket head cap screw (M4, length 22)
- Hexagon socket head cap screw (M5, length 16)

Motor bracket for MCM08

Reference number
MC-BK08-270-00

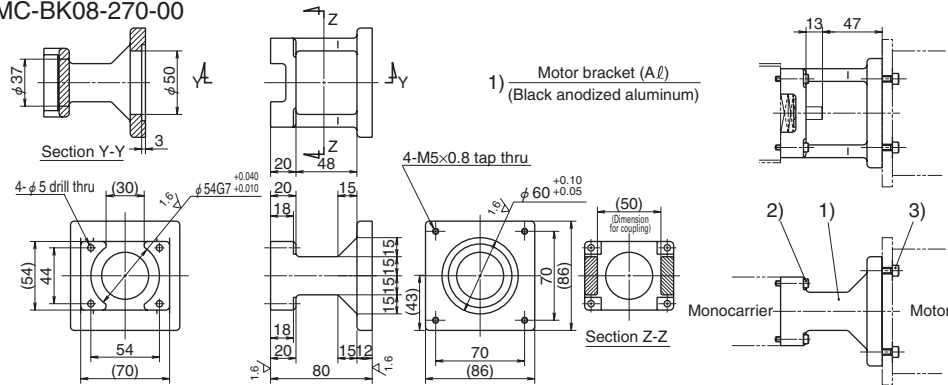

Notes: 1. Be sure to align centerlines when installing motor.
2. Be careful in the assembly orientation of bracket.
3. Because bracket is made by sand casting, external dimensions are for reference only.

Compatible motor	
Maker	Motor models
ORIENTAL MOTOR Co., Ltd.	AS98, UPK59x, PK59x
	CSK59x, CFK59x, UFK59x
SANYO DENKI Co., Ltd.	103F85xx

- Hexagon socket head cap screw (M4, length 22)
- Hexagon socket head cap screw (M5, length 16)

Motor bracket for MCM10

Reference number
MC-BK10-170-01

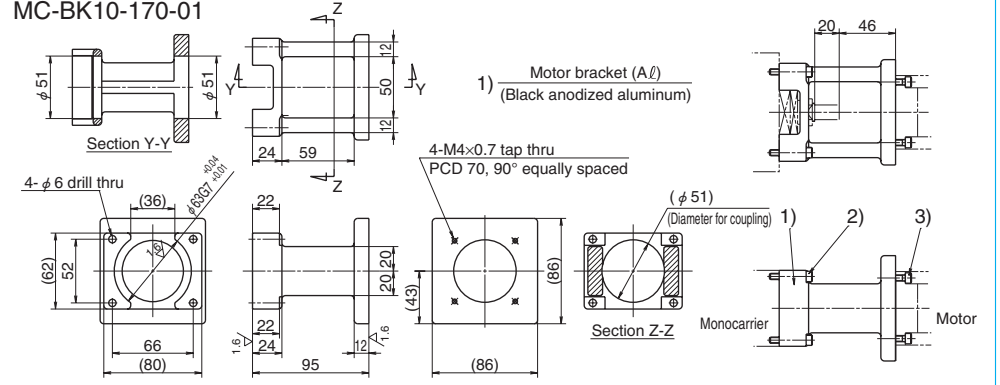

Notes: 1. Be sure to align centerlines when installing motor.
2. Be careful in the assembly orientation of bracket.
3. Because bracket is made by sand casting, external dimensions are for reference only.

Compatible motor	
Maker	Motor models
Panasonic Co., Ltd.	MSMD02(200W), MAMA02(200W), MSMD04(400W), MAMA04(400W)

- Hexagon socket head cap screw (M5, length 30)
- Hexagon socket head cap screw (M4, length 16)

Motor bracket for MCM10

Reference number
MC-BK10-170-00

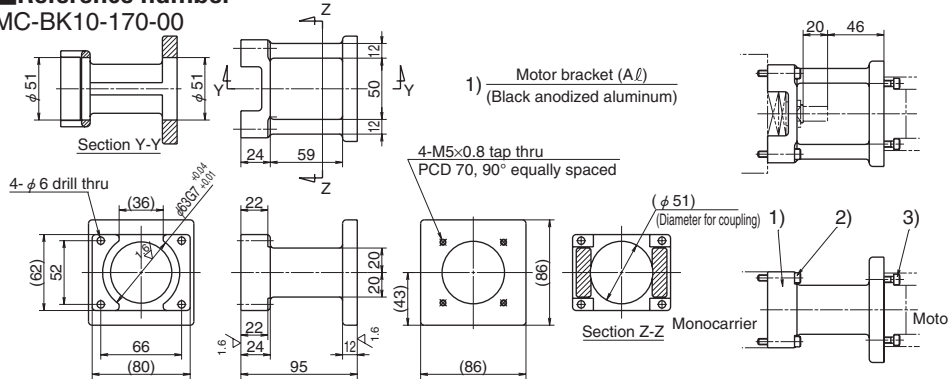

Notes: 1. Be sure to align centerlines when installing motor.
2. Be careful in the assembly orientation of bracket.
3. Because bracket is made by sand casting, external dimensions are for reference only.

Compatible motor	
Maker	Motor models
YASKAWA Electric Corp.	SGMJV-02A(200W), SGM4V-02A(200W), SGMJV-04A(400W), SGM4V-04A(400W)
Mitsubishi Electric Corp.	HF-KP23(200W), HF-MP23(200W), HF-KP43(400W), HF-MP43(400W) HC-KFS23(200W), HC-MFS23(200W), HC-KFS43(400W), HC-MFS43(400W)
OMRON Corp.	R88M-W20(200W), R88M-V40(400W)
SANYO DENKI Co., Ltd.	P30B06020(200W), P30B06040(400W)

- Hexagon socket head cap screw (M5, length 30)
- Hexagon socket head cap screw (M5, length 16)

Motor bracket for MCM10

Reference number
MC-BK10-190-00

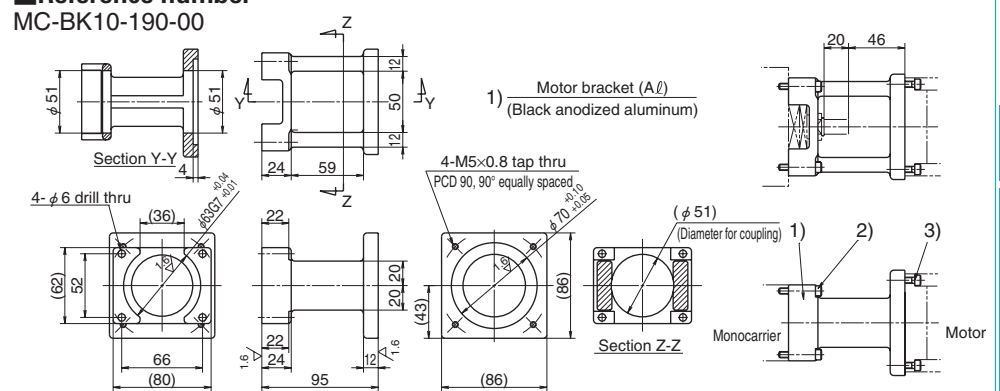

Notes: 1. Be sure to align centerlines when installing motor.
2. Be careful in the assembly orientation of bracket.
3. Because bracket is made by sand casting, external dimensions are for reference only.

Compatible motor	
Maker	Motor models
Panasonic Co., Ltd.	MSMD08(750W), MAMA08(750W)
SANYO DENKI Co., Ltd.	P50B07020(200W), P50B07030(300W), P50B07040(400W)

- Hexagon socket head cap screw (M5, length 30)
- Hexagon socket head cap screw (M5, length 16)

Motor bracket for MCM10

Reference number
MC-BK10-270-00

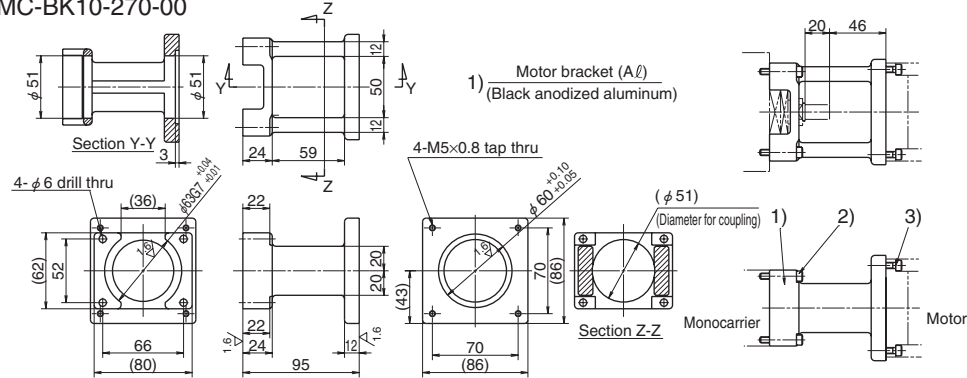

Notes: 1. Be sure to align centerlines when installing motor.
2. Be careful in the assembly orientation of bracket.
3. Because bracket is made by sand casting, external dimensions are for reference only.

Compatible motor	
Maker	Motor models
SANYO DENKI Co., Ltd.	103F85xx
ORIENTAL MOTOR Co., Ltd.	AS98, UPK59x, PK59x, CSK59x CFK59x, UFK59x

- 2) Hexagon socket head cap screw (M5, length 30)
- 3) Hexagon socket head cap screw (M5, length 18)

Motor Availability Table of Motor Bracket for MCM Series
Table 5

Model No.	Reference No. code	Motor bracket reference No.	Motor manufacturer	Stepping motor model No.	Wattage of AC servo motor													
					10	20	30	50	60	100	150	200	300	400	750			
MCM02	1	MC-BK02-128-00	YASKAWA Electric Corp.		SGMM-A1	SGMM-A2												
	2	MC-BK02-133-00	Mitsubishi Electric Corp.		HC-AQ013	HC-AQ023												
	3	MC-BK02-223-00	ORIENTAL MOTOR Co., Ltd.	PMU3305 (5-phase) PMC3305 (5-phase)														
MCM03	1	MC-BK03-146-00	YASKAWA Electric Corp.			SGMAH-A3		SGMJV-A5A SGMAV-A5A		SGMJV-01A SGMAV-01A		SGMAV-C2A						
			Mitsubishi Electric Corp.					HF-KP053 HF-MP053 HC-KFS053 HC-MFS053		HF-KP13 HF-MP13 HC-KFS13 HC-MFS13								
			OMRON Corp.					R88M-W03 R88M-W05		R88M-W10 R88M-W10								
MCM05	2	MC-BK03-148-01	SANYO DENKI Co., Ltd.					P30B04003	P30B04005		P50B04006	P50B04010						
			SANYO DENKI Co., Ltd.	PBM423xxx 103F55xx														
			ORIENTAL MOTOR Co., Ltd.	AS46, ASC46 UPK54x, PK54x CSK54x, CFK54x UMK24x, CSK24x PK24x														
MCM05	1	MC-BK05-145-00	Panasonic Co., Ltd.							MSMD5A		MSMD01						
			YASKAWA Electric Corp.				SGMAH-A3		SGMJV-A5A SGMAV-A5A		SGMJV-01A SGMAV-01A		SGMAV-C2A					
	2	MC-BK05-146-00	Mitsubishi Electric Corp.						HF-KP053 HF-MP053 HC-KFS053 HC-MFS053		HF-KP13 HF-MP13 HC-KFS13 HC-MFS13							
			OMRON Corp.						R88M-W03 R88M-W05		R88M-W10 R88M-W10							
			SANYO DENKI Co., Ltd.						P30B04003	P30B04005		P30B04010						
MCM06	3	MC-BK05-148-00	Panasonic Co., Ltd.									MAMA01						
			SANYO DENKI Co., Ltd.									P50B05005	P50B05010		P50B05020			
	4	MC-BK05-160-00	SANYO DENKI Co., Ltd.															
			SANYO DENKI Co., Ltd.	PBM603xxx PBM604xxx														
			ORIENTAL MOTOR Co., Ltd.	AS66, ASC66 UPK56x, UFK56x PK56x, CSK56x CFK56x														
MCM06	1	MC-BK06-145-00	Panasonic Co., Ltd.							MSMD5A		MSMD01						
			YASKAWA Electric Corp.						SGMJV-A5A SGMAV-A5A		SGMJV-01A SGMAV-01A		SGMAV-C2A					
	2	MC-BK06-146-00	Mitsubishi Electric Corp.						HF-KP053 HF-MP053 HC-KFS053 HC-MFS053		HF-KP13 HF-MP13 HC-KFS13 HC-MFS13							
			OMRON Corp.						R88M-W03 R88M-W05		R88M-W10 R88M-W10							
			SANYO DENKI Co., Ltd.						P30B04003	P30B04005		P30B04010						
			Panasonic Co., Ltd.										MAMA01					
			SANYO DENKI Co., Ltd.										P50B05005	P50B05010		P50B05020		
MCM06	5	MC-BK06-170-00	YASKAWA Electric Corp.										SGMJV-02A SGMAV-02A		SGMJV-04A SGMAV-04A			
			Mitsubishi Electric Corp.						HF-KP23 HF-MP23 HC-KFS23 HC-MFS23		HF-KP43 HF-MP43 HC-KFS43 HC-MFS43							
			OMRON Corp.						R88M-W20 R88M-W20		R88M-W40 R88M-W40							
		SANYO DENKI Co., Ltd.										P30B06020	P30B06040					
6	MC-BK06-170-01	Panasonic Co., Ltd.										MSMD02		MSMD04				
		SANYO DENKI Co., Ltd.										MAMA02		MAMA04				
		SANYO DENKI Co., Ltd.																
		ORIENTAL MOTOR Co., Ltd.							AS66, ASC66 UPK56x, PK56x CSK56x, CFK56x UFK56x									

Model No.	Reference No. code	Motor bracket reference No.	Motor manufacturer	Stepping motor model No.	Wattage of AC servo motor													
					10	20	30	50	60	100	150	200	300	400	750			
MCM08	1	MC-BK08-145-00	Panasonic Co., Ltd.							MSMD01								
			YASKAWA Electric Corp.						SGMJV-01A SGMAV-01A	SGMAV-C2A								
	2	MC-BK08-146-00	Mitsubishi Electric Corp.							HF-KP13 HF-MP13 HC-KFS13 HC-MFS13								
			SANYO DENKI Co., Ltd.			P30B04003	P30B04005		P30B04010									
			SANYO DENKI Co., Ltd.				P50B05005		P50B05010			P50B05020						
	4	MC-BK08-170-00	YASKAWA Electric Corp.								SGMJV-02A SGMAV-02A				SGMJV-04A SGMAV-04A			
			Mitsubishi Electric Corp.							HF-KP23 HF-MP23 HC-KFS23 HC-MFS23				HF-KP43 HF-MP43 HC-KFS43 HC-MFS43				
			OMRON Corp.									R88M-VV20			R88M-VV40			
			SANYO DENKI Co., Ltd.									P30B06020			P30B06040			
	5	MC-BK08-170-01	Panasonic Co., Ltd.										MSMD02 MAMA02		MSMD04 MAMA04			
	6	MC-BK08-190-00	SANYO DENKI Co., Ltd.											P50B07020	P50B07030	P50B07040		
	7	MC-BK08-250-00	SANYO DENKI Co., Ltd.	PBM603xxx PBM604xxx														
			SANYO DENKI Co., Ltd.	103F78xx														
			ORIENTAL MOTOR Co., Ltd.	AS98, ASC66 UPK56x, PK56x CSK56x, CFK56x UFK56x														
8	MC-BK08-270-00	SANYO DENKI Co., Ltd.	103F85xx															
		ORIENTAL MOTOR Co., Ltd.	AS98 UPK59x, PK59x CSK59x, CFK59x UFK59x															
MCM10	1	MC-BK10-170-00	YASKAWA Electric Corp.										SGMJV-02A SGMAV-02A		SGMJV-04A SGMAV-04A			
			Mitsubishi Electric Corp.								HF-KP23 HF-MP23 HC-KFS23 HC-MFS23			HF-KP43 HF-MP43 HC-KFS43 HC-MFS43				
			OMRON Corp.										R88M-VV20		R88M-VV40			
			SANYO DENKI Co., Ltd.										P30B06020		P30B06040			
	2	MC-BK10-170-01	Panasonic Co., Ltd.										MSMD02 MAMA02		MSMD04 MAMA04			
	3	MC-BK10-190-00	Panasonic Co., Ltd.														MSMD08 MAMA08	
			SANYO DENKI Co., Ltd.											P50B07020	P50B07030	P50B07040		
	4	MC-BK10-270-00	SANYO DENKI Co., Ltd.	103F85xx														
			ORIENTAL MOTOR Co., Ltd.	AS98 UPK59x, PK59x CSK59x, CFK59x UFK59x														



C-1-6 MCH Series

- | | |
|--|-----|
| 1. MCH Series Reference Number Coding | C73 |
| 2. MCH Series Dimension Table of Standard Products | |
| MCL06 | C74 |
| MCH06 | C75 |
| MCH09 | C77 |
| MCH10 | C79 |
| 3. MCH Series Accessories | |
| 3.1 Sensor Unit | C81 |
| 3.2 Cover Unit | C83 |
| 3.3 Intermediate Plate for Motor | C87 |

MCH Series

C-1-6 MCH Series

C-1-6. 1 MCH Series Reference Number Coding

[Body]

Example: **MC H 06 040 H 10 K (B2)**

Monocarrier

H Type: MCH Series
L Type: MCH Series low profile rail (only for 06 size)

Nominal size (rail width, Unit: 10mm)

Stroke (Unit: 10mm)

Accuracy grade (H, high grade; P, precision grade)

*1

NSK management number (0 or 2)
Grease specification: B (LG2) (See page C140.)
Slider specification K: Single slider
D: Double slider (See page C14.)
Ball screw lead (mm)

Note: *1: These two code fields are added except for standard grease.

14th digit is control No. of NSK. Customers cannot specify a number. See the pages of each nominal number for details.

[With Accessories]

Example: **MC S 06 040 H 10 K 0 2 K 0 0 0**

S: With MCH Accessories
R: With MCL Accessories

NSK management number
Sensor unit
Cover unit
Intermediate plate for motor

Note: Option parts are available separately.

Table 1 Sensor unit (See page C81.)

Reference No. code	Specification	Reference No.
0	N/A	—
1	Proximity switch (Normally close contact 3 pieces)	MC—SRHxx—10
2	Proximity switch (Normally open contact 3 pieces)	MC—SRHxx—11
3	Proximity switch (Normally open contact 1 piece, Normally close contact 2 pieces)	MC—SRHxx—12
4	Photo sensor 3 pieces	MC—SRHxx—13

Notes: 1) xx: Nominal size
2) Sensor rail is not included in a sensor unit. If you require the rail, please specify upon ordering. (See page C81 to C82.)

Table 2 Cover unit (See page C83 to C85.)

Reference No. code	Specification	Reference No.
0	N/A	—
1	For single slider	MC—HVxxxx—00
	For double slider	MC—HVxxxxD00

Note: xxxxx; Nominal size and stroke number

Table 3 Intermediate plate for motor (See page C87 to C90.)

Reference No. code	Model No.		
	MCH06 (MCL06)	MCH09	MCH10
0	N/A	N/A	N/A
1	MC-BKH06-145-00	MC-BKH09-145-00	MC-BKH10-170-00
2	MC-BKH06-146-00	MC-BKH09-146-00	MC-BKH10-170-01
3	MC-BKH06-231-00	MC-BKH09-170-00	MC-BKH10-190-00
4	MC-BKH06-250-00	MC-BKH09-170-01	MC-BKH10-190-01
5	—	MC-BKH09-231-00	MC-BKH10-250-00
6	—	MC-BKH09-250-00	MC-BKH10-270-00

N/A: Not applicable

C-1-6. 2 MCH Series Dimension Table of Standard Products

MCL06

Accuracy grade: High grade (H)

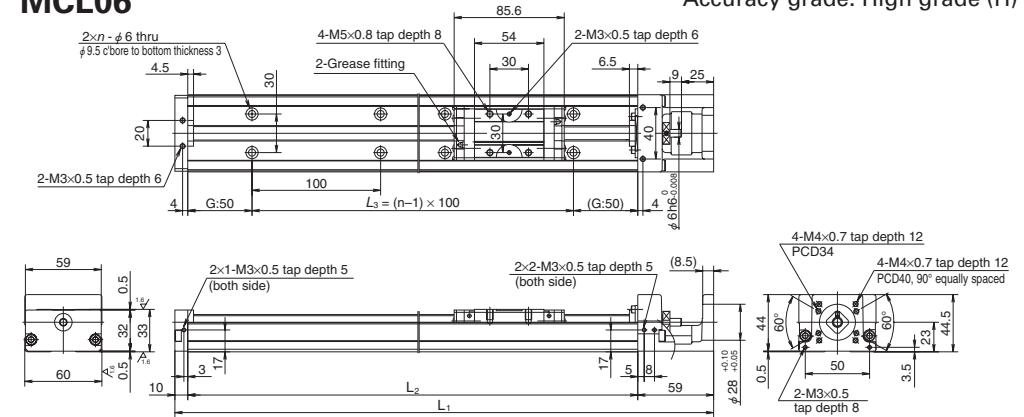

- Rail of MCL 06 is made lighter than that of MCH 06 by lowering rail height. Weight ratio between MCH 06 and MCL 06 is 5 to 4.
- Double slider specification is also available for MCL 06.
- Combinations of stroke and ball screw lead of MCL 06 are the same as those of MCH 06.

Dimension of MCL06 (Single slider)

Reference No.	Nominal stroke (mm)	Stroke limit (mm) (without K1)	Ball screw lead (mm)	Body length (mm)				Inertia $\times 10^{-6}(\text{kg} \cdot \text{m}^2)$	Mass (kg)
				L ₁	L ₂	L ₃	n		
◇ MCL06005H05K02	50	53	5	219	150	100	2	2.38	1.0
◇ MCL06005H10K02		(65)	10					3.45	
MCL06010H05K02	100	103	5	269	200	100	2	3.17	1.3
MCL06010H10K02		(115)	10					4.12	
MCL06020H05K02	200	203	5	369	300	200	3	4.51	1.9
MCL06020H10K02		(215)	10					5.46	
MCL06030H10K02	300	303	10	469	400	300	4	6.80	2.6
MCL06030H20K02		(315)	20					10.6	
MCL06040H10K02	400	403	10	569	500	400	5	8.13	3.2
MCL06040H20K02		(415)	20					11.9	
MCL06050H10K02	500	503	10	669	600	500	6	9.47	3.9
MCL06050H20K02		(515)	20					13.3	

Notes: 1. Dimension G is 25 for items marked with ◇.
2. The nominal number in the above table is for high-grade grease specifications. In the case of other specifications, see the following table for the 13th and 14th digits.

Coding for columns 13 and 14

Grease	High-grade	Precision-grade
Standard	02	(None)
LG2	B2	B0

Ball screw lead (mm)	Monocarrier dynamic torque specification (N · cm)	
	5	1.0 - 4.8
	10	1.1 - 5.8
20	1.6 - 7.9	

Notes:
1. Frictional resistance of NSK K1 is included in dynamic torque in table.
2. Grease is packed into ball screw, linear guide parts and support unit.
3. Consult NSK for life estimates under large moment loads.

Basic load rating

Lead l (mm)	Shaft dia d (mm)	Basic dynamic load rating (N)				Basic static load rating (N)		Support unit load limit (N)
		Ball screw C_a	Linear guides C	Support unit C_a	Rated running distance L_a (km)	Ball screw C_{0a}	Linear guides C_0	
5	φ 12	3 760	22 800	4 400	5	6 310	16 300	1 450
10		2 420	18 100		10	3 790		
20		2 420	14 400		20	3 790		

Basic static moment load of linear guide

Slider	Basic static moment load (N · m)		
	Rolling M_{R0}	Pitching M_{P0}	Yawing M_{Y0}
Single	335	133	133

MCH06

Accuracy grade: High grade (H)

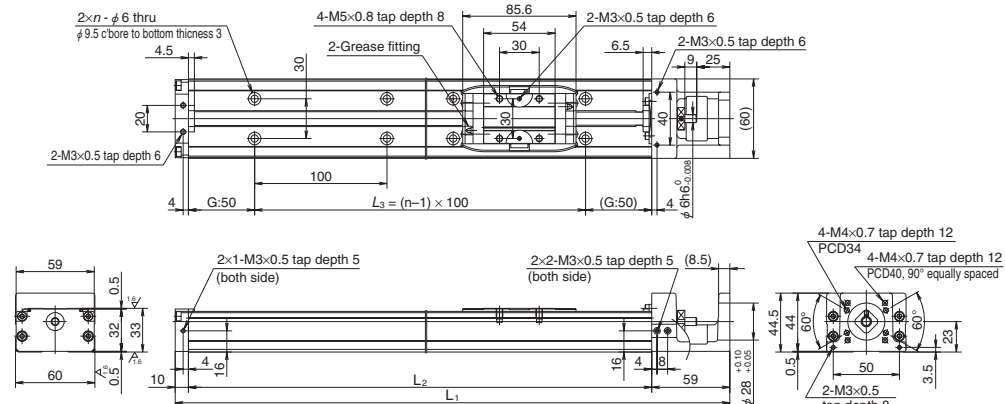

Dimension of MCH06 (Single slider)

Reference No.	Nominal stroke (mm)	Stroke limit (mm) (without K1)	Ball screw lead (mm)	Body length (mm)				Inertia $\times 10^{-6}(\text{kg} \cdot \text{m}^2)$	Mass (kg)
				L ₁	L ₂	L ₃	n		
◇ MCH06005H05K02	50	53 (65)	5	219	150	100	2	2.38	1.8
◇ MCH06005H10K02			10					3.45	
◇ MCH06005H20K02			20					7.25	
MCH06010H05K02	100	103 (115)	5	269	200	100	2	3.17	2.2
MCH06010H10K02			10					4.12	
MCH06010H20K02			20					7.92	
MCH06020H05K02	200	203 (215)	5	369	300	200	3	4.51	3.0
MCH06020H10K02			10					5.46	
MCH06020H20K02			20					9.26	
MCH06030H05K02	300	303 (315)	5	469	400	300	4	5.85	3.7
MCH06030H10K02			10					6.80	
MCH06030H20K02			20					10.6	
MCH06040H05K02	400	403 (415)	5	569	500	400	5	7.18	4.5
MCH06040H10K02			10					8.13	
MCH06040H20K02			20					11.9	
MCH06050H05K02	500	503 (515)	5	669	600	500	6	8.52	5.2
MCH06050H10K02			10					9.47	
MCH06050H20K02			20					13.3	

Notes: 1. Dimension G is 25 for items marked with ◇.
2. The nominal number in the above table is for high-grade grease specifications. In the case of other specifications, see the following table for the 13th and 14th digits.

Coding for columns 13 and 14

Grease	High-grade	Precision-grade	Monocarrier dynamic torque specification (N · cm)		Notes: 1. Frictional resistance of NSK K1 is included in dynamic torque in table. 2. Grease is packed into ball screw, linear guide parts and support unit. 3. Consult NSK for life estimates under large moment loads.
Standard	02	(None)	Ball screw lead (mm)	5	
LG2	B2	B0		10	
			20		
				1.0 - 4.8	
				1.1 - 5.8	
				1.6 - 7.9	

Basic load rating

Lead l (mm)	Shaft dia d (mm)	Basic dynamic load rating (N)				Basic static load rating (N)		Support unit load limit (N)
		Ball screw C_a	Linear guides C	Support unit C_a	Rated running distance L_a (km)	Ball screw C_{0a}	Linear guides C_0	
5	φ 12	3 760	22 800	4 400	5	6 310	16 300	1 450
10		2 420	18 100		10	3 790		
20		2 420	14 400		20	3 790		

Basic static moment load of linear guide

Slider	Basic static moment load (N · m)		
	Rolling M_{RO}	Pitching M_{PO}	Yawing M_{VO}
Single	335	133	133

MCH06 (Double slider)

Accuracy grade: High grade (H)

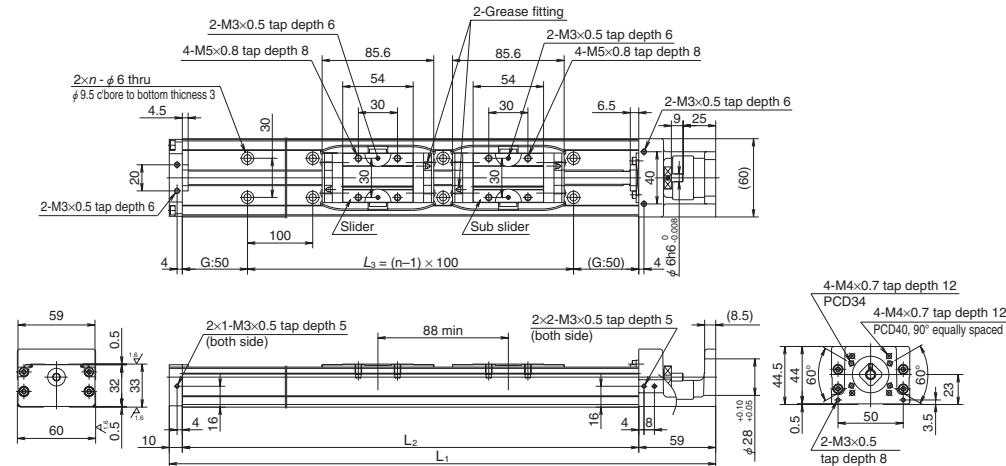

Dimension of MCH06 (Double slider)

Reference No.	Nominal stroke (mm)	Stroke limit (mm) (without K1)	Ball screw lead (mm)	Body length (mm)				Inertia $\times 10^{-6}(\text{kg} \cdot \text{m}^2)$	Mass (kg)
				L ₁	L ₂	L ₃	n		
MCH06010H05D02	100	115 (139)	5	369	300	200	3	4.82	3.5
MCH06010H10D02			10					6.72	
MCH06020H05D02	200	215 (239)	5	469	400	300	4	8.06	4.2
MCH06020H10D02			10					15.7	
MCH06030H05D02	300	315 (339)	5	569	500	400	5	9.40	5.0
MCH06030H10D02			10					17.0	
MCH06040H10D02	400	415 (439)	10	669	600	500	6	10.7	5.7
MCH06040H20D02			20					18.3	

Note: The nominal number in the above table is for high-grade grease specifications. In the case of other specifications, see the following table for the 13th and 14th digits.

Coding for columns 13 and 14

Grease	High-grade	Precision-grade	Monocarrier dynamic torque specification (N · cm)		Notes: 1. Frictional resistance of NSK K1 is included in dynamic torque in table. 2. Grease is packed into ball screw, linear guide parts and support unit. 3. Consult NSK for life estimates under large moment loads.
Standard	02	(None)	Ball screw lead (mm)	5	
LG2	B2	B0		10	
			20		
				1.2 - 5.2	
				1.5 - 9.6	
				2.3 - 11.8	

Basic load rating

Lead l (mm)	Shaft dia d (mm)	Basic dynamic load rating (N)				Basic static load rating (N)		Support unit load limit (N)
		Ball screw C_a	Linear guides C	Support unit C_a	Rated running distance L_a (km)	Ball screw C_{0a}	Linear guides C_0	
5	φ 12	3 760	22 800	4 400	5	6 310	16 300	1 450
10		2 420	18 100		10	3 790		
20		2 420	14 400		20	3 790		

Basic static moment load of linear guide

Slider	Basic static moment load (N · m)		
	Rolling M_{RO}	Pitching M_{PO}	Yawing M_{VO}
Double	770	730	730

MCH10

Accuracy grade: High grade (H)

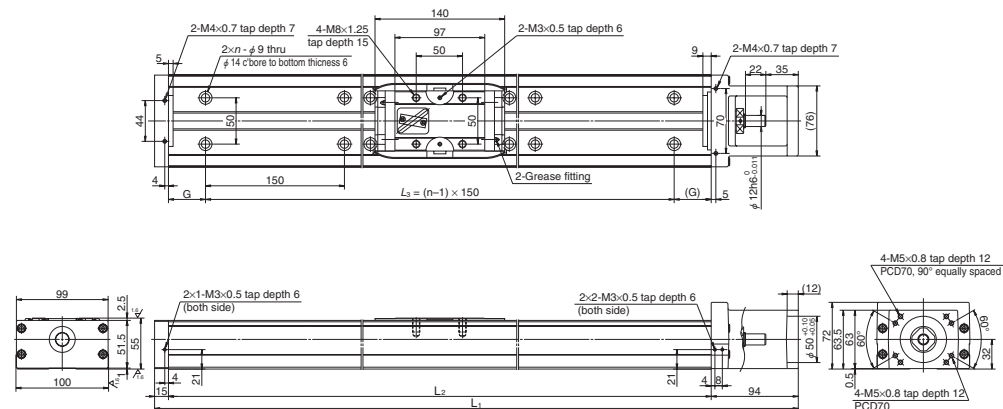

Dimension of MCH10 (Single slider)

Reference No.	Nominal stroke (mm)	Stroke limit (mm) (without K1)	Ball screw lead (mm)	Body length (mm)					Inertia $\times 10^6$ (kg · m ²)	Mass (kg)
				L ₁	L ₂	G	L ₃	n		
MCH10010H10K02	100	126 (142)	10	389	280	65	150	2	33.2	7.3
MCH10010H20K02		226 (242)	20						41.1	
MCH10020H10K02	200	226 (242)	10	489	380	40	300	3	43.4	9.5
MCH10020H20K02		326 (342)	20						51.3	
MCH10030H10K02	300	326 (342)	10	589	480	15	450	4	53.7	12
MCH10030H20K02		426 (442)	20						61.6	
MCH10040H10K02	400	426 (442)	10	689	580	65	450	4	62.4	14
MCH10040H20K02		526 (542)	20						71.8	
MCH10050H10K02	500	526 (542)	10	789	680	40	600	5	74.7	16
MCH10050H20K02		626 (642)	20						82.3	
MCH10060H10K02	600	626 (642)	10	889	780	15	750	6	84.9	19
MCH10060H20K02		726 (742)	20						92.5	
MCH10070H10K02	700	726 (742)	10	989	880	65	750	6	95.1	21
MCH10070H20K02		826 (842)	20						103	
MCH10080H10K02	800	826 (842)	10	1 089	980	40	900	7	105	23
MCH10080H20K02		926 (942)	20						113	
MCH10090H10K02	900	926 (942)	10	1 189	1 080	15	1 050	8	116	25
MCH10090H20K02		1 026 (1 042)	20						123	
MCH10100H10K02	1 000	1 026 (1 042)	10	1 289	1 180	65	1 050	8	126	27
MCH10100H20K02		1 126 (1 142)	20						133	
MCH10110H10K02	1 100	1 126 (1 142)	10	1 389	1 280	40	1 200	9	136	29
MCH10110H20K02		1 226 (1 242)	20						143	
MCH10120H10K02	1 200	1 226 (1 242)	10	1 489	1 380	15	1 350	10	146	32
MCH10120H20K02			20						154	

Note: The nominal number in the above table is for high-grade grease specifications. In the case of other specifications, see the following table for the 13th and 14th digits.

Coding for columns 13 and 14

Grease	High-grade	Precision-grade	Monocarrier dynamic torque specification (N · cm)		
Standard	O2	(None)	Ball screw lead (mm)	10	2.7 – 10.8
LG2	B2	B0		20	3.1 – 12.7

- Notes:
- Frictional resistance of NSK K1 is included in dynamic torque in table.
 - Grease is packed into ball screw, linear guide parts and support unit.
 - Consult NSK for life estimates under large moment loads.

Basic load rating

Lead ℓ (mm)	Shaft dia d (mm)	Basic dynamic load rating (N)				Basic static load rating (N)		Support unit load limit (N)
		Ball screw C_a	Linear guides C	Support unit C_a	Rated running distance L_a (km)	Ball screw C_{0a}	Linear guides C_0	
10	$\phi 20$	11 000	44 600	7 600	10	21 100	42 000	3 380
20		7 060	35 400		20	12 700		

Basic static moment load of linear guide

Slider	Basic static moment load (N · m)		
	Rolling M_{R0}	Pitching M_{P0}	Yawing M_{Y0}
Single	1 460	610	610

MCH10 (Double slider)

Accuracy grade: High grade (H)

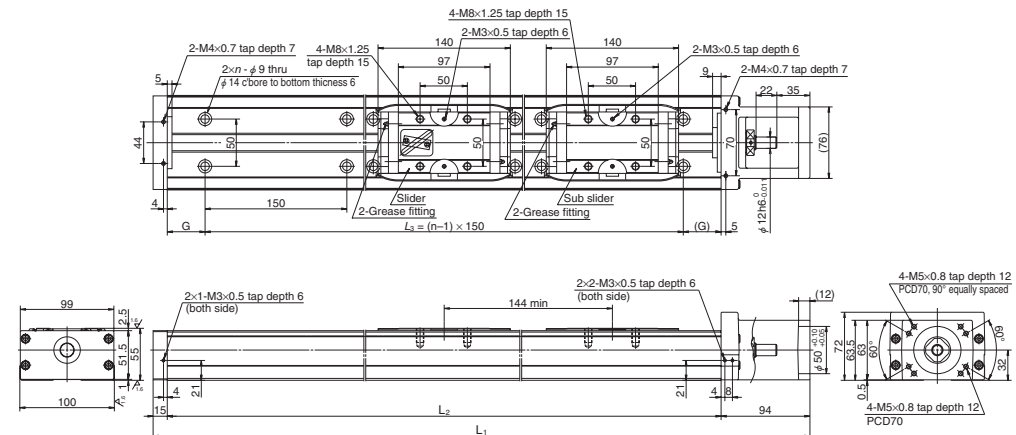

Dimension of MCH10 (Double slider)

Reference No.	Nominal stroke (mm)	Stroke limit (mm) (without K1)	Ball screw lead (mm)	Body length (mm)					Inertia $\times 10^6$ (kg · m ²)	Mass (kg)
				L ₁	L ₂	G	L ₃	n		
MCH10025H10D02	250	282 (314)	10	689	580	65	450	4	67.1	15
MCH10025H20D02		382 (414)	20						82.4	
MCH10035H10D02	350	382 (414)	10	789	680	40	600	5	77.3	17
MCH10035H20D02		482 (514)	20						92.5	
MCH10045H10D02	450	482 (514)	10	889	780	15	750	6	87.5	20
MCH10045H20D02		582 (614)	20						103	
MCH10055H10D02	550	582 (614)	10	989	880	65	750	6	97.7	22
MCH10055H20D02		682 (714)	20						113	
MCH10065H10D02	650	682 (714)	10	1 089	980	40	900	7	108	24
MCH10065H20D02		782 (814)	20						123	
MCH10075H20D02	750	782 (814)	20	1 189	1 080	15	1 050	8	133	26
MCH10085H20D02	850	882 (914)	20	1 289	1 180	65	1 050	8	143	28
MCH10095H20D02	950	982 (1 014)	20	1 389	1 280	40	1 200	9	154	30
MCH10105H20D02	1 050	1 082 (1 114)	20	1 489	1 380	15	1 350	10	164	33

Note: The nominal number in the above table is for high-grade grease specifications. In the case of other specifications, see the following table for the 13th and 14th digits.

Coding for columns 13 and 14

Grease	High-grade	Precision-grade	Monocarrier dynamic torque specification (N · cm)		
Standard	O2	(None)	Ball screw lead (mm)	10	4.2 – 15.6
LG2	B2	B0		20	5.0 – 19.6

- Notes:
- Frictional resistance of NSK K1 is included in dynamic torque in table.
 - Grease is packed into ball screw, linear guide parts and support unit.
 - Consult NSK for life estimates under large moment loads.

Basic load rating

Lead ℓ (mm)	Shaft dia d (mm)	Basic dynamic load rating (N)				Basic static load rating (N)		Support unit load limit (N)
		Ball screw C_a	Linear guides C	Support unit C_a	Rated running distance L_a (km)	Ball screw C_{0a}	Linear guides C_0	
10	$\phi 20$	11 000	44 600	7 600	10	21 100	42 000	3 380
20		7 060	35 400		20	12 700		

Basic static moment load of linear guide

Slider	Basic static moment load (N · m)		
	Rolling M_{R0}	Pitching M_{P0}	Yawing M_{Y0}
Double	2 920	3 430	3 430

C-1-6. 3 MCH Series Accessories

C-1-6. 3. 1 Sensor Unit

● Proximity switch

Sensor rail is not included in a sensor unit.

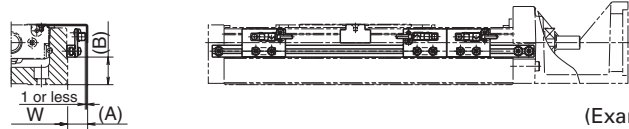

(Example of assembly)

Model No.	Reference No.			A (mm)	B (mm)	Body width W (mm)
MCH06	MC-SRH06-10	MC-SRH06-11	MC-SRH06-12	17	10	60
MCH09	MC-SRH09-10	MC-SRH09-11	MC-SRH09-12	16	21	86
MCH10	MC-SRH10-10	MC-SRH10-11	MC-SRH10-12	16	16	100
Quantity	Proximity switch (normally open contact)	—	3	1	E2S-W13 (OMRON Corp.)	
	Proximity switch (normally close contact)	3	—	2	E2S-W14 (OMRON Corp.)	

Notes: 1. See page C135 for proximity switch specifications. 2. A sensor unit consists of sensors, a sensor dog and sensor mounting parts.

● Photo sensor

Sensor rail is not included in a sensor unit.

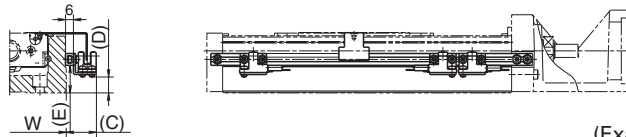

(Example of assembly)

Model No.	Reference No.	C (mm)	D (mm)	E (mm)	Body width W (mm)	Remarks
MCH06	MC-SRH06-13	24	2	11	60	EE-SX674 (OMRON Corp.)
MCH09	MC-SRH09-13	23	12	21	86	3 sets
MCH10	MC-SRH10-13	23	29	16	100	(EE-1001 connector attachment)

Notes: 1. See page C136 for proximity switch specifications. 2. A sensor unit consists of sensors, a sensor dog and sensor mounting parts.

(1) Sensor rail

Reference number: MC-SRL- * * * *

● * * * * is the same as rail dimension L_2 .

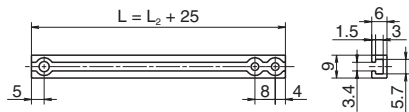

Note: For combinations of sensors and rails, see page C82.

Body of MCH Series and Sensor Rail Combination Table

Table 4

Model No.	Body length L_2 (mm)	Reference No.	Sensor rail reference No.
MCH06	150	MCH06005H05K02	MC-SRL-0150
		MCH06005H10K02	
		MCH06005H20K02	
	200	MCH06010H05K02	MC-SRL-0200
		MCH06010H10K02	
		MCH06010H20K02	
300	MCH06020H05K02	MC-SRL-0300	
	MCH06020H10K02		
	MCH06020H20K02		
MCH09	840	MCH09070H05K02	MC-SRL-0840
		MCH09070H10K02	
		MCH09070H20K02	
	940	MCH09080H05K02	MC-SRL-0940
		MCH09080H10K02	
		MCH09080H20K02	
MCH10	280	MCH10010H10K02	MC-SRL-0280
		MCH10010H20K02	
		MCH10020H20K02	
	380	MCH10020H10K02	MC-SRL-0380
		MCH10020H20K02	
		MCH10030H10K02	
	480	MCH10030H20K02	MC-SRL-0480
		MCH10030H10K02	
	580	MCH10040H10K02	MC-SRL-0580
		MCH10025H10D02	
	680	MCH10050H10K02	MC-SRL-0680
		MCH10050H20K02	
MCH10035H10D02			
780	MCH10060H10K02	MC-SRL-0780	
	MCH10060H20K02		
	MCH10045H10D02		
880	MCH10045H20D02	MC-SRL-0880	
	MCH10070H10K02		
	MCH10070H20K02		
980	MCH10055H10D02	MC-SRL-0980	
	MCH10055H20D02		
	MCH10080H10K02		
1 080	MCH10080H20K02	MC-SRL-1080	
	MCH10065H10D02		
	MCH10065H20D02		
1 180	MCH10090H10K02	MC-SRL-1180	
	MCH10090H20K02		
	MCH10075H20D02		
1 280	MCH10100H10K02	MC-SRL-1280	
	MCH10100H20K02		
	MCH10085H20D02		
1 380	MCH10101H10K02	MC-SRL-1380	
	MCH10101H20K02		
	MCH10105H20D02		
MCH09	150	MCL06005H05K02	MC-SRL-0150
		MCL06005H10K02	
		MCL06010H10K02	
	200	MCL06010H05K02	MC-SRL-0200
		MCL06010H10K02	
		MCL06020H05K02	
	300	MCL06020H10K02	MC-SRL-0300
		MCL06020H10K02	
		MCL06030H10K02	
	400	MCL06030H20K02	MC-SRL-0400
		MCL06030H10K02	
		MCL06040H10K02	
500	MCL06040H20K02	MC-SRL-0500	
	MCL06040H10D02		
	MCL06040H20D02		
600	MCL06050H10K02	MC-SRL-0600	
	MCL06050H20K02		
	MCL06050H20K02		
MCH09	240	MCH09010H05K02	MC-SRL-0240
		MCH09010H10K02	
		MCH09010H20K02	
	340	MCH09020H05K02	MC-SRL-0340
		MCH09020H10K02	
		MCH09020H20K02	
	440	MCH09030H05K02	MC-SRL-0440
		MCH09030H10K02	
		MCH09030H20K02	
		MCH09015H05D02	
		MCH09015H10D02	
		MCH09015H20D02	
540	MCH09040H05K02	MC-SRL-0540	
	MCH09040H10K02		
	MCH09040H20K02		
	MCH09025H05D02		
	MCH09025H10D02		
	MCH09025H20D02		
640	MCH09050H05K02	MC-SRL-0640	
	MCH09050H10K02		
	MCH09050H20K02		
	MCH09035H05D02		
	MCH09035H10D02		
	MCH09035H20D02		
740	MCH09060H05K02	MC-SRL-0740	
	MCH09060H10K02		
	MCH09060H20K02		
	MCH09045H10D02		
	MCH09045H20D02		
	MCH09045H20D02		

C-1-6. 3. 2 Cover Unit

Cover unit for MCH06 and MCL06

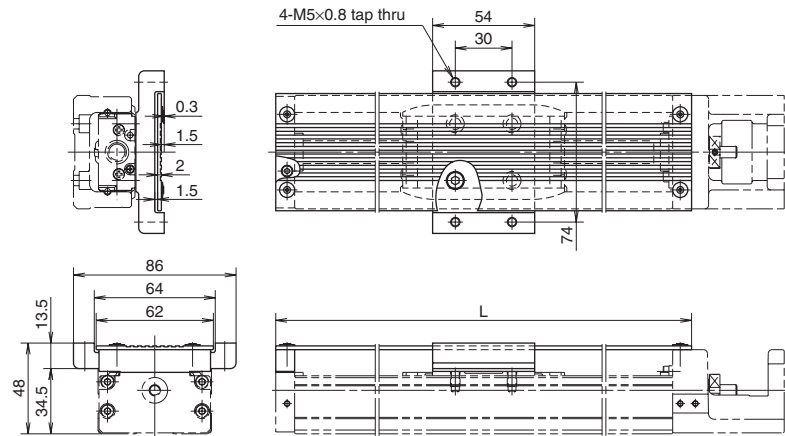

Unit: mm

Single slider		Double slider		Top cover length L
Stroke	Reference No.	Stroke	Reference No.	
50	MC-HV06005-00	-	-	170
100	MC-HV06010-00	-	-	220
200	MC-HV06020-00	100	MC-HV06010D00	320
300	MC-HV06030-00	200	MC-HV06020D00	420
400	MC-HV06040-00	300	MC-HV06030D00	520
500	MC-HV06050-00	400	MC-HV06040D00	620

Cover unit for MCH09

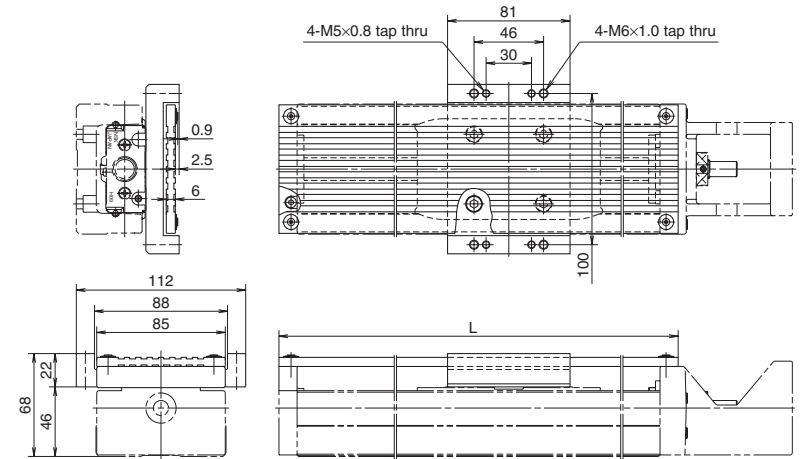

Unit: mm

Single slider		Double slider		Top cover length L
Stroke	Reference No.	Stroke	Reference No.	
100	MC-HV09010-00	-	-	264
200	MC-HV09020-00	-	-	364
300	MC-HV09030-00	150	MC-HV09015D00	464
400	MC-HV09040-00	250	MC-HV09025D00	564
500	MC-HV09050-00	350	MC-HV09035D00	664
600	MC-HV09060-00	450	MC-HV09045D00	764
700	MC-HV09070-00	-	-	864
800	MC-HV09080-00	650	MC-HV09065D00	964

● Cover unit for double sliders

Two spacers are provided for double slider.

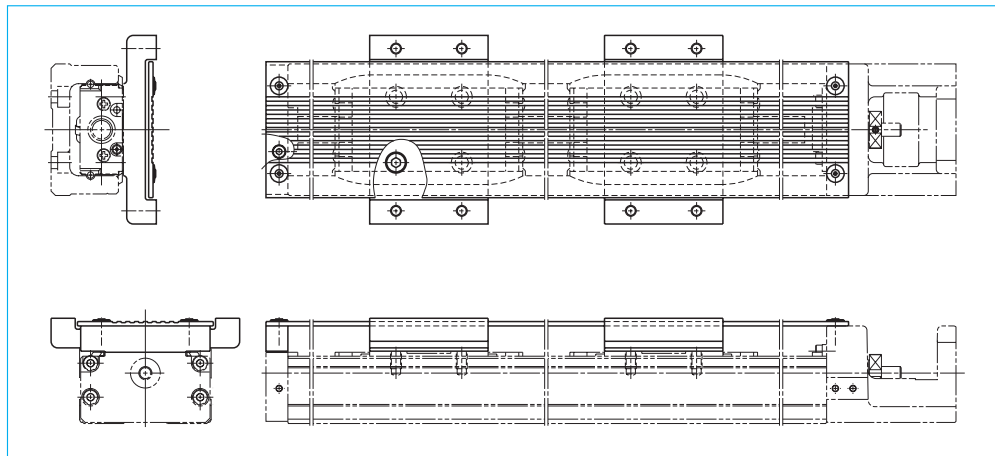

● Cover unit for double sliders

Two spacers are provided for double slider.

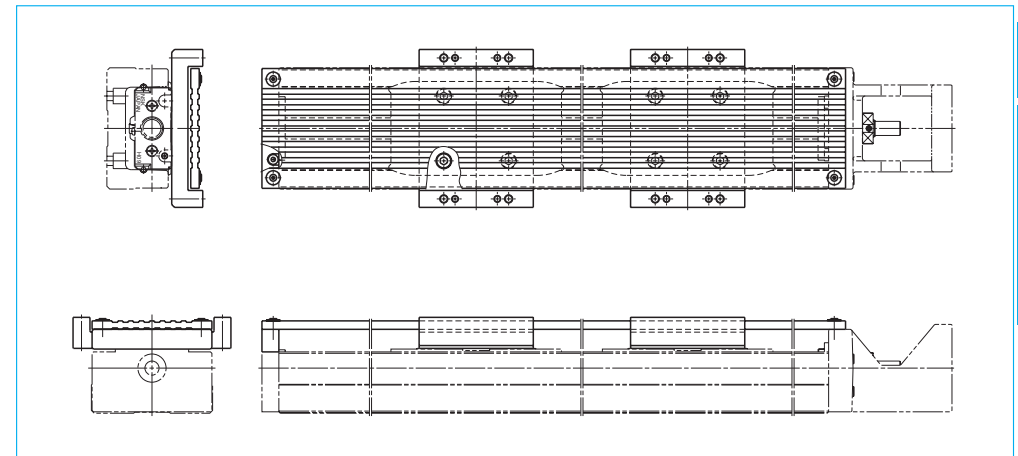

Cover unit for MCH10

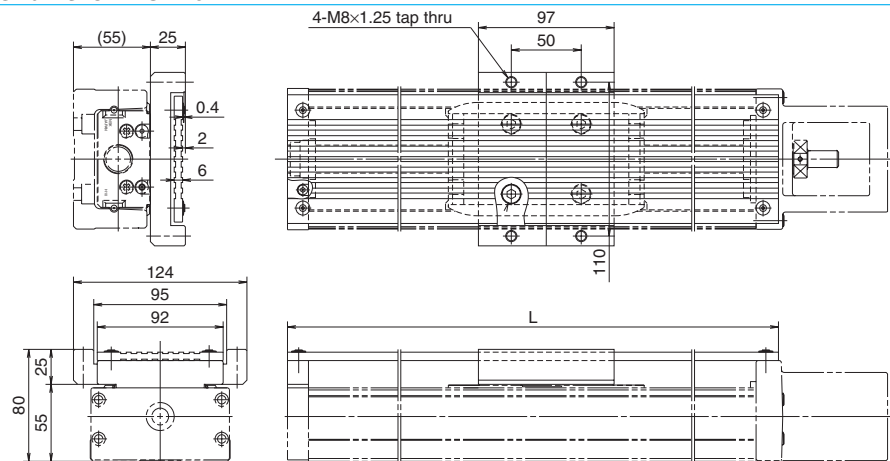

Unit: mm

Single slider		Double slider		Top cover length L
Stroke	Reference No.	Stroke	Reference No.	
100	MC-HV10010-00	-	-	310
200	MC-HV10020-00	-	-	410
300	MC-HV10030-00	-	-	510
400	MC-HV10040-00	250	MC-HV10025D00	610
500	MC-HV10050-00	350	MC-HV10035D00	710
600	MC-HV10060-00	450	MC-HV10045D00	810
700	MC-HV10070-00	550	MC-HV10055D00	910
800	MC-HV10080-00	650	MC-HV10065D00	1 010
900	MC-HV10090-00	750	MC-HV10075D00	1 110
1 000	MC-HV10100-00	850	MC-HV10085D00	1 210
1 100	MC-HV10110-00	950	MC-HV10095D00	1 310
1 200	MC-HV10120-00	1 050	MC-HV10105D00	1 410

●Cover unit for double sliders

Two spacers are provided for double slider.

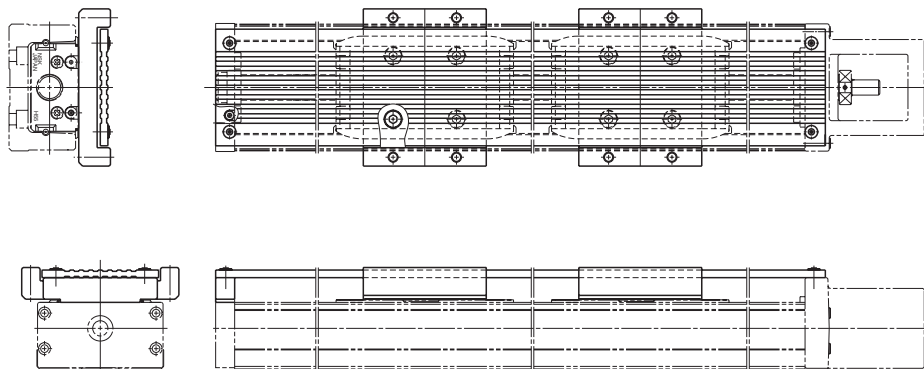

C-1-6. 3. 3 Intermediate Plate for Motor

- Please ask NSK about motors not listed in compatible motor list.
- In case of parallel motor mount, please consult with NSK. ● Be sure to align centerlines when installing motor.
- Motor models are subject to change at the motor manufacturers. For details, please contact the manufacturer.

Motor Bracket for MCH06 and MCL06

Reference number: MC-BKH06-145-00

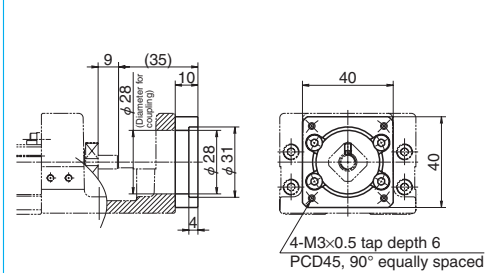

Compatible motor	
Maker	Motor models
Panasonic Co., Ltd.	MSMD5A(50W), MSMD01(100W)

Reference number: MC-BKH06-146-00

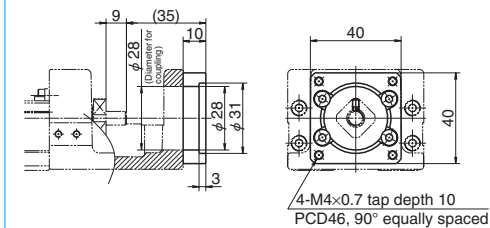

Compatible motor	
Maker	Motor models
YASKAWA Electric Corp.	SGMAH-A3(30W), SGMJV-A5A(50W), SGMVA-A5A(50W) SGMJV-01A(100W), SGMVA-01A(100W)
Mitsubishi Electric Corp.	HF-KP053(50W), HF-MP053(50W), HC-KFS053(50W) HC-MFS053(50W), HF-KP13(100W), HF-MP13(100W) HC-KFS13(100W), HC-MFS13(100W)
OMRON Corp.	R88M-W03(30W), R88M-W05(50W), R88M-W10(100W)
SANYO DENKI Co., Ltd.	P30B04xxx P Series

Reference number: MC-BKH06-231-00

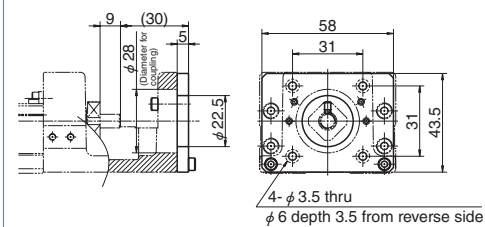

Compatible motor	
Maker	Motor models
ORIENTAL MOTOR Co., Ltd.	AS46, ASC46, UPK54x, PK54x, CSK54x, CFK54x, UMK24x, CSK24x, PK24x
SANYO DENKI Co., Ltd.	PBM423xxx, 103F55xx

Reference number: MC-BKH06-250-00

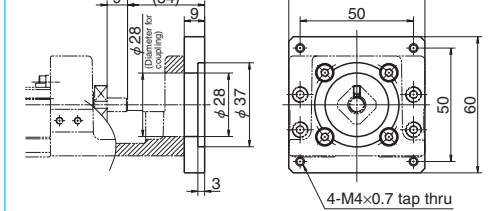

Compatible motor	
Maker	Motor models
ORIENTAL MOTOR Co., Ltd.	AS66, ASC66, UPK56x, UFK56x, PK56x, CSK56x, CFK56x
OMRON Corp.	MUMS02(200W), MUMS04(400W)
SANYO DENKI Co., Ltd.	PBM603xx, PBM604xx, 103F78xx

Motor Bracket for MCH09

Reference number: MC-BKH09-145-00
MC-BKH09-146-00

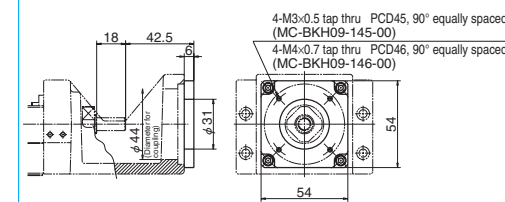

Reference No.	Compatible motor	
	Maker	Motor models
MC-BKH09-145-00	Panasonic Co., Ltd.	MSMD5A(50W), MSMD01(100W)
MC-BKH09-146-00	YASKAWA Electric Corp.	SGMJV-ASA(50W), SGMVA-ASA(50W) SGMJV-01A(100W), SGMVA-01A(100W)
	Mitsubishi Electric Corp.	HF-KP053(50W), HF-MP053(50W), HC-KFS053(50W) HC-MFS053(50W), HF-KP13(100W), HF-MP13(100W) HC-KFS13(100W), HC-MFS13(100W)
MC-BKH09-146-00	OMRON Corp.	R88M-W05(50W), R88M-W10(100W)
	SANYO DENKI Co., Ltd.	P30B04xxx P Series

Reference number: MC-BKH09-170-00
MC-BKH09-170-01

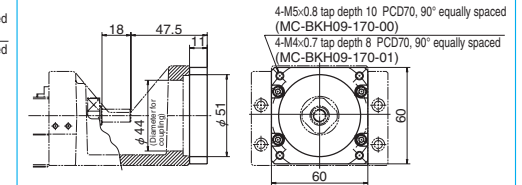

Reference No.	Compatible motor	
	Maker	Motor models
MC-BKH09-170-00	YASKAWA Electric Corp.	SGMJV-02A(200W), SGMVA-02A(200W) SGMJV-04A(400W), SGMVA-04A(400W)
	Mitsubishi Electric Corp.	HF-KP23(200W), HF-MP23(200W), HF-KP43(400W) HF-MP43(400W), HC-KFS23(200W), HC-MFS23(200W) HC-KFS43(400W), HC-MFS43(400W)
MC-BKH09-170-01	OMRON Corp.	R88M-W20(200W), R88M-W40(400W)
	SANYO DENKI Co., Ltd.	P30B06xxx P Series MSMD02(200W), MSMA02(200W) MSMA04(400W), MSMD04(400W)

Reference number: MC-BKH09-231-00

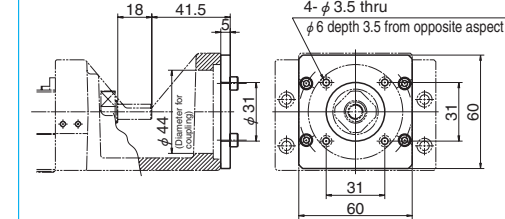

Compatible motor	
Maker	Motor models
SANYO DENKI Co., Ltd.	PBM423xxx, 103F55xx
ORIENTAL MOTOR Co., Ltd.	AS46, ASC46, UPK54x, PK54x, CSK54x, CFK54x UMK24x, CSK24x, PK24x

Reference number: MC-BKH09-250-00

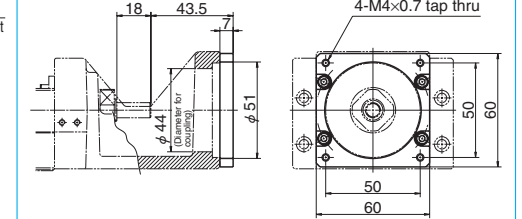

Compatible motor	
Maker	Motor models
SANYO DENKI Co., Ltd.	PBM603xx, PBM604xx, 103F78xx
ORIENTAL MOTOR Co., Ltd.	AS66, ASC66, UPK56x, UFK56x, PK56x CSK56x, CFK56x

Diameter of ball screw shaft end to install a pulley for parallel motor mount of MCH06

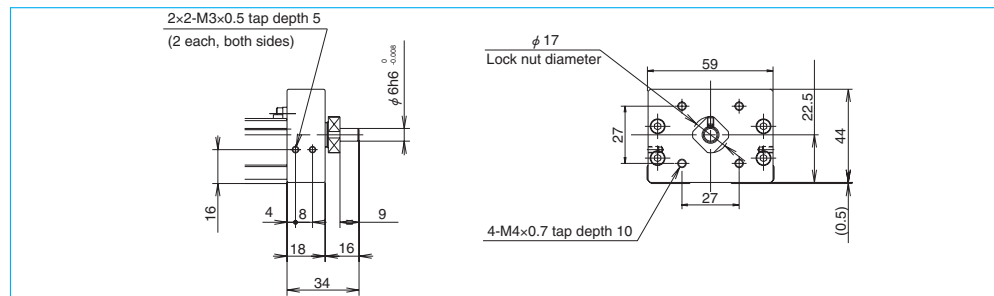

Diameter of ball screw shaft end to install a pulley for parallel motor mount of MCH09

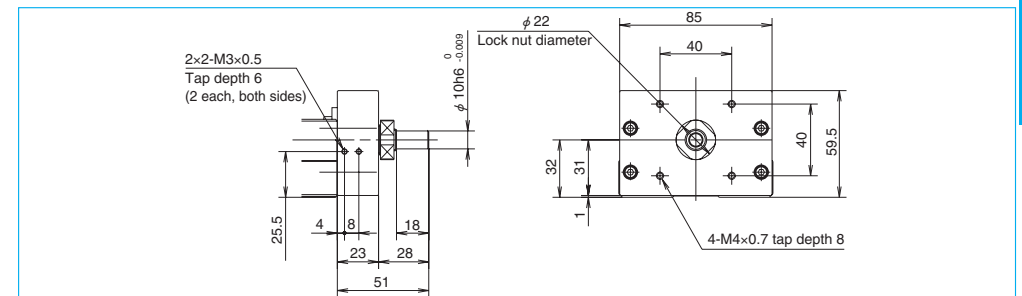

Motor Bracket for MCH10

Reference number: MC-BKH10-170-00
MC-BKH10-170-01

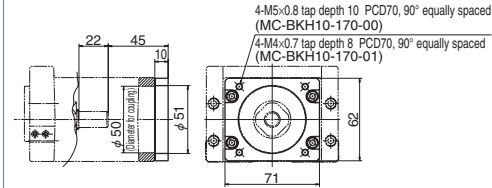

Reference No.	Compatible motor	
	Maker	Motor models
MC-BKH10-170-00	YASKAWA Electric Corp.	SGMJV-02A(200W), SGM4V-02A(200W) SGMJV-04A(400W), SGM4V-04A(400W)
	Mitsubishi Electric Corp.	HF-KP23(200W), HF-MP23(200W), HF-KP43(400W) HF-MP43(400W), HC-KFS23(200W), HC-MFS23(200W) HC-KFS43(400W), HC-MFS43(400W)
	OMRON Corp.	R88M-W20(200W), R88M-W40(400W)
	SANYO DENKI Co., Ltd.	P30B06xxx P Series
MC-BKH10-170-01	Panasonic Co., Ltd.	MSMD02(200W), MSMA02(200W) MSMD04(400W), MSMA04(400W)

Reference number: MC-BKH10-190-00
MC-BKH10-190-01

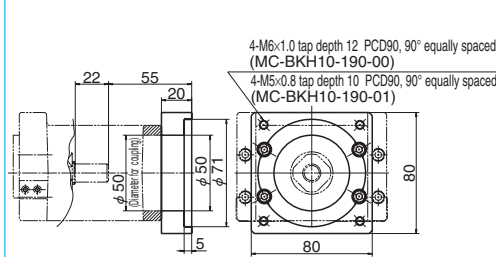

Reference No.	Compatible motor	
	Maker	Motor models
MC-BKH10-190-00	Mitsubishi Electric Corp.	HC-KFS73(750W), HC-MFS73(750W) HF-KP73(750W), HF-MP73(750W)
MC-BKH10-190-01	SANYO DENKI Co., Ltd.	P50B07xxx P Series

Reference number: MC-BKH10-250-00

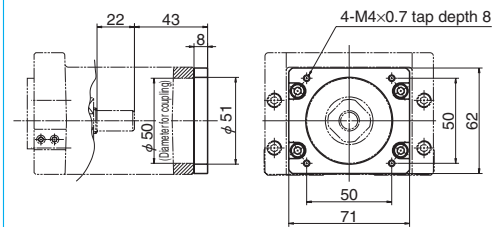

Compatible motor	
Maker	Motor models
SANYO DENKI Co., Ltd.	PBM603xx, PBM604xx, 103F78xx
ORIENTAL MOTOR Co., Ltd.	AS66, ASC66, UPK56x, PK56x, CSK56x, CFK56x UMK56x, UFK56x

Reference number: MC-BKH10-270-00

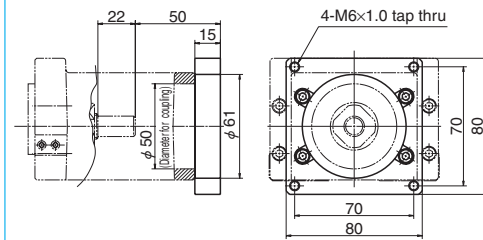

Compatible motor	
Maker	Motor models
ORIENTAL MOTOR Co., Ltd.	AS98, ASC98, UPK59x, PK59x, CSK59x, CFK59x UMK59x, UFK59x

Diameter of ball screw shaft end to install a pulley for parallel motor mount of MCH10

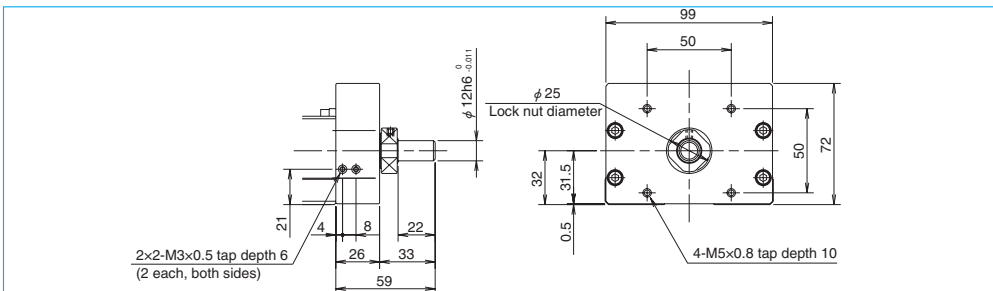

Motor Availability Table of Intermediate Plate for MCH Series

Table 5

Model No.	Reference No. code	Motor bracket reference No.	Motor manufacturer	Stepping motor model No.	Wattage of AC servo motor						
					30	50	100	200	400	750	
MCH06 MCL06	1	MC-BKH06-145-00	Panasonic Co., Ltd.								
			YASKAWA Electric Corp.		SGMAH-A3	MSMD5A SGMJV-A5A SGMAV-A5A	MSMD01 SGMJV-01A SGMAV-01A				
			Mitsubishi Electric Corp.			HF-KP053 HF-MP053 HC-KFS053 HC-MFS053	HF-KP13 HF-MP13 HC-KFS13 HC-MFS13				
	2	MC-BKH06-146-00	OMRON Corp.								
			SANYO DENKI Co., Ltd.	P30B04xxx (P Series)	R88M-W03	R88M-W05	R88M-W10				
			SANYO DENKI Co., Ltd.	PBM423xxx 103F55xx							
	3	MC-BKH06-231-00	Panasonic Co., Ltd.								
			ORIENTAL MOTOR Co., Ltd.			AS46, ASC46 UPK54x, PK54x CSK54x, CFK54x UMK24x, CSK24x PK24x					
			SANYO DENKI Co., Ltd.	PBM603xx PBM604xx 103F78xx							
	4	MC-BKH06-250-00	ORIENTAL MOTOR Co., Ltd.								
			SANYO DENKI Co., Ltd.	P30B04xxx (P Series)	R88M-W03	R88M-W05	R88M-W10				
			OMRON Corp.								
MCH09	1	MC-BKH09-145-00	Panasonic Co., Ltd.								
			YASKAWA Electric Corp.			MSMD5A SGMJV-A5A SGMAV-A5A	MSMD01 SGMJV-01A SGMAV-01A				
			Mitsubishi Electric Corp.			HF-KP053 HF-MP053 HC-KFS053 HC-MFS053	HF-KP13 HF-MP13 HC-KFS13 HC-MFS13				
	2	MC-BKH09-146-00	OMRON Corp.								
			SANYO DENKI Co., Ltd.	P30B04xxx (P Series)	R88M-W05	R88M-W10					
			YASKAWA Electric Corp.								
	3	MC-BKH09-170-00	Mitsubishi Electric Corp.								
			OMRON Corp.								
			SANYO DENKI Co., Ltd.	P30B06xxx (P Series)	R88M-W20	R88M-W40					
	4	MC-BKH09-170-01	Panasonic Co., Ltd.								
			SANYO DENKI Co., Ltd.	P30B06xxx (P Series)	R88M-W20	R88M-W40					
			YASKAWA Electric Corp.								
5	MC-BKH09-231-00	SANYO DENKI Co., Ltd.									
		ORIENTAL MOTOR Co., Ltd.			AS46, ASC46 UPK54x, PK54x CSK54x, CFK54x UMK24x, CSK24x PK24x						
		SANYO DENKI Co., Ltd.	PBM603xx PBM604xx 103F78xx								
6	MC-BKH09-250-00	ORIENTAL MOTOR Co., Ltd.									
		SANYO DENKI Co., Ltd.	P30B06xxx (P Series)	R88M-W20	R88M-W40						
		OMRON Corp.									
MCH10	1	MC-BKH10-170-00	YASKAWA Electric Corp.								
			Mitsubishi Electric Corp.			SGMJV-02A SGMAV-02A SGMJV-04A SGMAV-04A	SGMJV-01A SGMAV-01A				
			OMRON Corp.			HF-KP23 HF-MP23 HC-KFS23 HC-MFS23	HF-KP43 HF-MP43 HC-KFS43 HC-MFS43				
	2	MC-BKH10-170-01	SANYO DENKI Co., Ltd.	P30B06xxx (P Series)	R88M-W20	R88M-W40					
			Panasonic Co., Ltd.								
			YASKAWA Electric Corp.								
	3	MC-BKH10-190-00	Mitsubishi Electric Corp.								
			OMRON Corp.								
			SANYO DENKI Co., Ltd.	P30B06xxx (P Series)	R88M-W20	R88M-W40					
	4	MC-BKH10-190-01	SANYO DENKI Co., Ltd.	P50B07xxx (P Series)							
			SANYO DENKI Co., Ltd.	PBM603xx PBM604xx 103F78xx							
			ORIENTAL MOTOR Co., Ltd.	AS66, ASC66 UPK56x, PK56x CSK56x, CFK56x UMK56x, UFK56x							
5	MC-BKH10-250-00	ORIENTAL MOTOR Co., Ltd.									
		SANYO DENKI Co., Ltd.	P30B06xxx (P Series)	R88M-W20	R88M-W40						
		OMRON Corp.									
6	MC-BKH10-270-00	ORIENTAL MOTOR Co., Ltd.									
		SANYO DENKI Co., Ltd.	P30B06xxx (P Series)	R88M-W20	R88M-W40						
		OMRON Corp.									

C-2 Toughcarrier™

1. Features	C93
2. Classification and Series	C93
3. Accessories	C95
4. Selection of Toughcarrier	C96
4.1 Selection Procedures	C96
4.2 Stroke and Lead	C97
4.3 Reference Number Coding and Accuracy Grade	C98
4.4 Maximum Speed	C99
4.5 Rigidity	C101
4.6 Basic Load Rating	C102
4.7 Estimation of Life Expectancy	C103
4.8 Example of Life Estimation	C105
5. TCH Series Dimension Table for Standard Products	C109
5.1 TCH06 Series	C109
5.2 TCH09 Series	C111
5.3 TCH10 Series	C113
6. Accessories	C115
6.1 Sensor Unit	C115
6.2 Cover Unit	C116
6.3 Motor Bracket	C119
7. Motor Bracket Compatibility Table	C128
8. Sensor Rail and Top Cover Unit Combination Table	C129
9. Toughcarrier High-Thrust Series	C132

C-2 Toughcarrier™

C-2 Toughcarrier™

C-2-1 Features

Greatly improved load capacity due to switching of rolling elements to rollers.
Mounting dimensions are compatible with those of the MCH Series, allowing substitution.

● **Light weight and compact design**

Taking into account part composition and rigidity, the cross sections of the rail and slider are the same as MCH series.

● **Superb rust-preventive ability**

Low-temperature chrome plating comes standard.

● **All-in-one structure**

- 1) The all-in-one structure integrates a ball screw, a linear guide and a support unit into a single structure to significantly reduce design time.
- 2) The bottom and one side of the rail are datum surfaces to facilitate highly accurate installation. Models with pin holes are also available as standard.
- 3) Immediate operation after installation and run-in is possible due to pre-packed grease.
- 4) A wide selection of ball screw leads are available.

● **Long-term maintenance-free operation**

Use of NSK K1 lubrication unit and grease maintains smooth lubricating performance for long periods.

● **Updated rolling elements**

Rollers are installed as rolling elements for the first time anywhere.

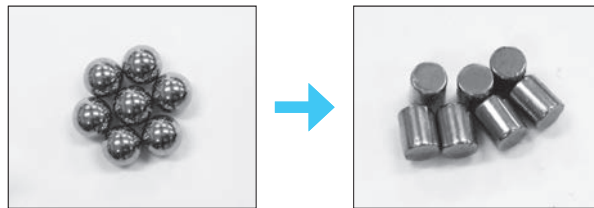

C-2-2 Classification and Series

Structure

Rolling elements: Balls

MCH Series

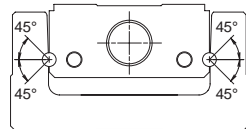

Rolling elements: Rollers

TCH Series

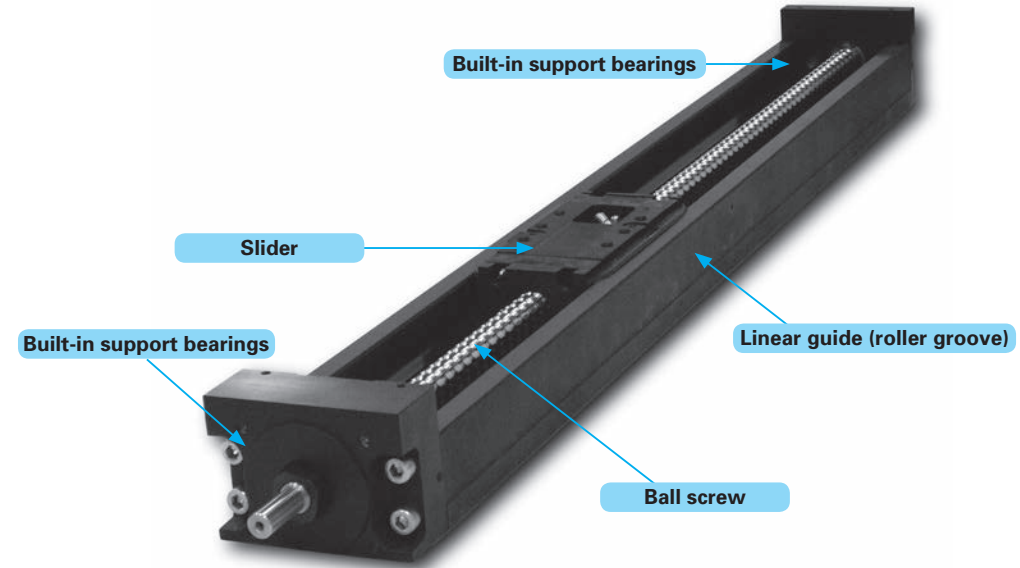
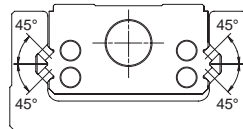

● **High rigidity, long life (N)**

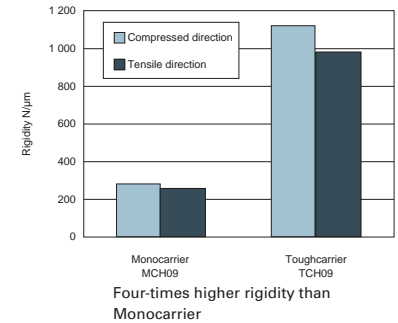
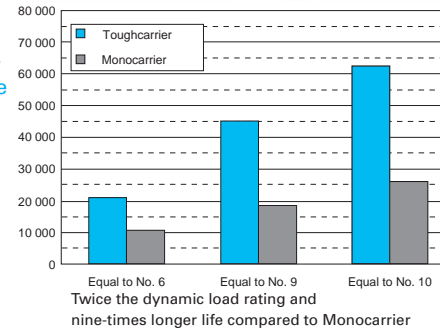

Cross-sections of TCH Series

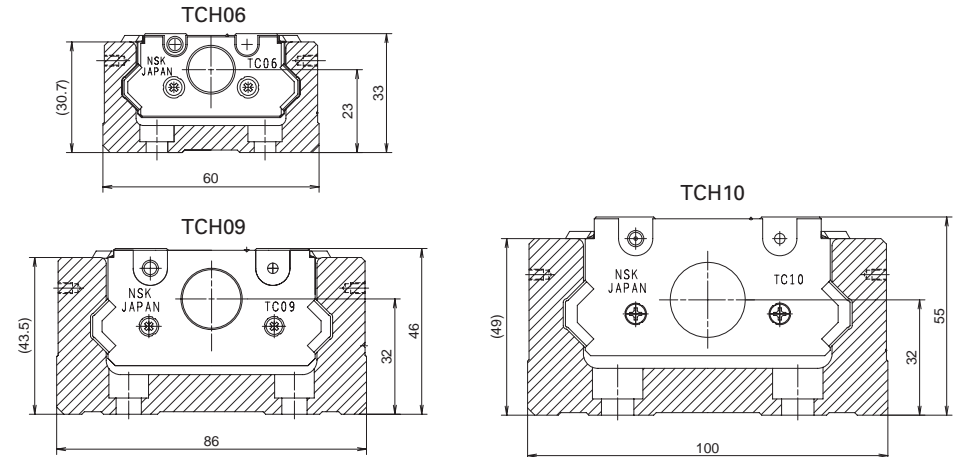

C-2-3 Accessories

Accessories for Toughcarrier

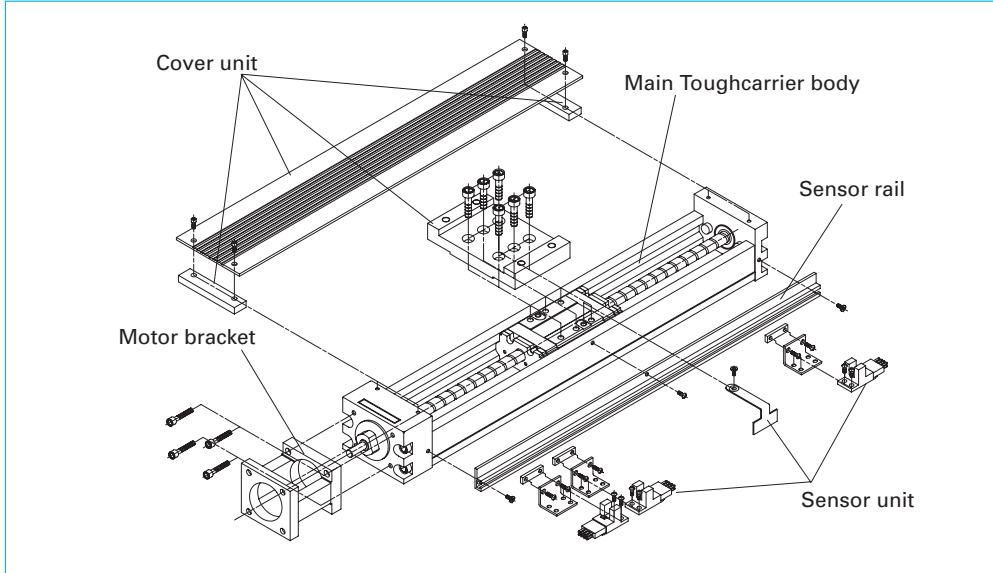

Assembly Example of accessories

Sensor unit, cover unit, motor bracket and sensor rail are available as options for Toughcarrier. Contact NSK for other specifications other than those of NSK standard accessories.

1. Sensor unit:
 - Photo sensor...Use of OMRON EE-SX674 and EE-1001
 - Proximity switch...Use of OMRON E2S-W13, E2S-W14
 Available in a unit including sensor fitting clamps.
2. Sensor rail : This rail holds the sensor. Please order the appropriate rail according to the stroke.
3. Cover unit : This unit consists of a top cover and spacer plate.
4. Motor bracket: Brackets are available for a variety of models from different motor manufacturers. Please consult NSK when the mounting dimensions differ from your order.

C-2-4 Selection of Toughcarrier

C-2-4. 1 Selection Procedure for Toughcarrier

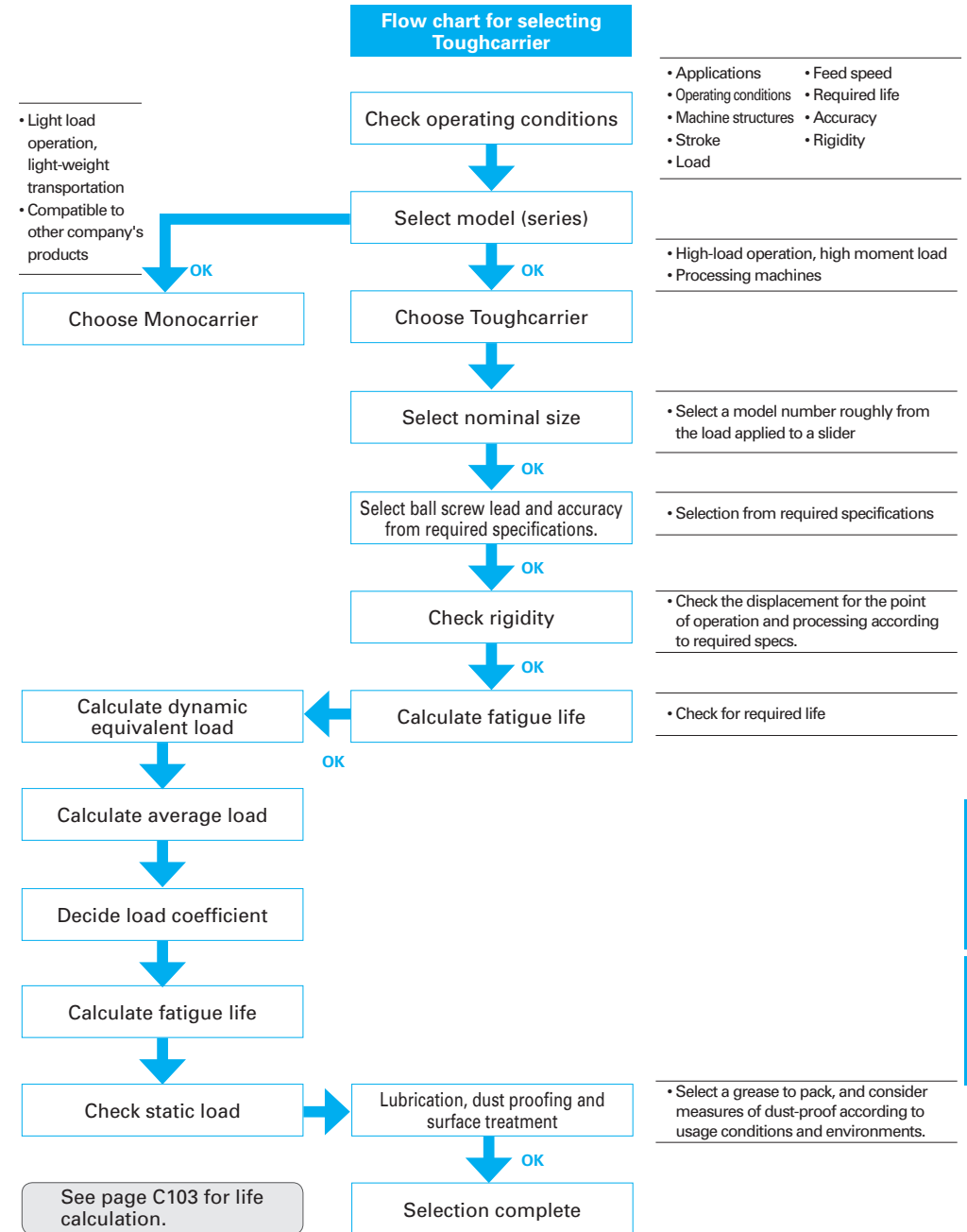

C-2-4. 2 Stroke and Lead

◆ Combinations of rail length and lead

● TCH06

Slider type Lead (mm) Rail length (mm)	Standard slider						Short slider					
	Single slider			Double slider			Single slider			Double slider		
	5	10	20	5	10	20	5	10	20	5	10	20
150	✓	✓	✓				✓	✓				
200	✓	✓	✓				✓	✓				
300	✓	✓	✓	✓	✓		✓	✓		✓	✓	
400	✓	✓	✓	✓	✓		✓	✓		✓	✓	
500	✓	✓	✓	✓	✓		✓	✓		✓	✓	
600	✓	✓	✓		✓	✓	✓	✓			✓	✓

*20 mm lead for short sliders not available.

● TCH09

Slider type Lead (mm) Rail length (mm)	Standard slider						Short slider					
	Single slider			Double slider			Single slider			Double slider		
	5	10	20	5	10	20	5	10	20	5	10	20
240	✓	✓	✓				✓	✓	✓			
340	✓	✓	✓				✓	✓	✓			
440	✓	✓	✓	✓	✓		✓	✓	✓	✓	✓	
540	✓	✓	✓	✓	✓		✓	✓	✓	✓	✓	
640	✓	✓	✓	✓	✓		✓	✓	✓	✓	✓	
740	✓	✓	✓		✓	✓	✓	✓	✓		✓	✓
840	✓	✓	✓		✓	✓	✓	✓	✓		✓	✓
940	✓	✓	✓		✓	✓	✓	✓	✓		✓	✓

● TCH10

Slider type Lead (mm) Rail length (mm)	Standard slider				Short slider			
	Single slider		Double slider		Single slider		Double slider	
	10	20	10	20	10	20	10	20
280	✓	✓			✓	✓		
380	✓	✓			✓	✓		
480	✓	✓			✓	✓		
580	✓	✓	✓	✓	✓	✓	✓	✓
680	✓	✓	✓	✓	✓	✓	✓	✓
780	✓	✓	✓	✓	✓	✓	✓	✓
880	✓	✓	✓	✓	✓	✓	✓	✓
980	✓	✓	✓	✓	✓	✓	✓	✓
1 080	✓	✓			✓	✓		
1 180	✓	✓			✓	✓		
1 280	✓	✓			✓	✓		
1 380	✓	✓			✓	✓		

◆ Availability

Model No.	Lead (mm)	Slider	Rail length (mm)
TCH06	5, 10, 20	Single	600
		Double	
TCH09	5, 10, 20	Single	940
		Double	
TCH10	10, 20	Single	1 380
		Double	

C-2-4. 3 Reference Number Coding and Accuracy Grade

● Reference number coding for TCH Series

Body
Reference number: TC H 06 030 H 10 K 0 0

Toughcarrier
 Model: TCH Series
 (with accessories: TCS)
 Nominal size (rail width, 10 mm units)
 Stroke (10 mm units)
 Accuracy grade: H, High grade; P, Precision grade

NSK control number (0: without pin holes)
 (1: with pin holes)
 Grease (0: YS2, standard)
 Slider specification*
 Ball screw lead (mm)

* K: Single slider
 D: Double slider
 A: Single short slider
 B: Double short slider

Special specifications
Reference number: TC H 06 030 H 10 K - □ XXB

3: Toughcarrier for special specs
 5: Toughcarrier high-thrust series*
 * For the specifications of the High-Thrust Series, see page C132.

Design serial number

● Reference number for accessories

1. Sensor unit
Reference number: TC - SRH XX - 00
 Toughcarrier
 Sensor unit
 Nominal size: 06, 09 and 10
 Control no.: see page C115

2. Sensor rail
Reference number: TC - SRL X - XXXX
 Toughcarrier
 Sensor rail
 Nominal size: 06 is 6, 09 is 9, and 10 is 1.
 Body rail length

3. Cover unit
Reference number: TC - HV XX XXX - K 00
 Toughcarrier
 Cover unit
 Nominal size: 06, 09 and 10
 Stroke (nominal)
 Slider specs: refer to the body reference no.
 Control no.: See pages C116 to C118

4. Motor bracket
Reference number: TC - BKH XX - XXX - 00
 Toughcarrier
 Motor bracket
 Nominal size: 06, 09 and 10
 Dimension for motor mounting
 Control no.

◆ Accuracy grade

Stroke (mm)	High grade (H grade)			Precision grade (P grade)			
	Repeatability	Running parallelism (vertical)	Backlash	Repeatability	Positioning accuracy	Running parallelism (vertical)	Backlash
~ 200	±10	14	20 or less	±3	20	8	3 or less
~ 400		16			10		
~ 600		20			12		
~ 700		23			15		
~ 1 000						35	
~ 1 200						40	

High and precision grades are available for accuracy grade. Consult NSK for your requirements.

C-2-4. 4 Maximum Speed

● Maximum speed (standard slider)

Maximum speed of the Toughcarrier is determined by the critical speed of the ball screw shaft and the $d \cdot n$ value.

Do not exceed the maximum speed in the table below.

	Stroke (nominal)	Ball screw lead (mm)	Body rail length L_2 (mm)	Maximum speed (mm/s)
TCH06 Single slider	50	5	150	250
	100		200	
	200		300	
	300		400	
	400		500	
	500	600		
	100	10	150	500
	200		200	
	300		300	
	400		400	
	500		500	
	600	600		
	100	20	150	1 000
	200		200	
	300		300	
400	400			
500	500			
600	600			
TCH06 Double slider	130	5	300	250
	230		400	
	330		500	
	130		300	
	230		400	
	330	500		
	430	10	600	500
	430		600	
	430		600	
	430		600	
430	600			
430	20	600	1 000	
100		240		
200		340		
300		440		
400		540		
500	640			
TCH09 Single slider	600	5	740	250
	700		840	
	800		940	
	100		240	
	200		340	
	300	440		
	400	540	500	
	500	640		
	600	740		
	700	840		
	800	940		
	100	10	240	410
	200		340	
	300		440	
	400		540	
500	640			
600	20	740	1 000	
700		840		
800		940		
100		240		
200		340		
300	440			
400	540	820		
500	640			
600	740			
700	840			
800	940			

Note: If you need to operate the Toughcarrier near the critical speed or in excess of the maximum speed in the table, please consult NSK.

● Maximum speed (short slider)

Maximum speed of the Toughcarrier is determined by the critical speed of the ball screw shaft and the $d \cdot n$ value.

Do not exceed the maximum speed in the table below.

	Stroke (nominal)	Ball screw lead (mm)	Body rail length L_2 (mm)	Maximum speed (mm/s)	
TCH06 Single slider	70	5	150	250	
	120		200		
	220		300		
	320		400		
	420		500		
	520	600			
	70	10	150	500	
	120		200		
	220		300		
	320		400		
	420		500		
	520	600			
	TCH06 Double slider	170	5	300	250
		270		400	
		370		500	
470		600			
570		700			
670		800			
170		10	400	500	
270			500		
370			600		
470			700		
570	800				
TCH09 Single slider	140	5	240	250	
	240		340		
	340		440		
	440		540		
	540		640		
	640	740			
	740	10	840	500	
	840		940		
	140		240		
	240		340		
	340		440		
	440	540	1 000		
	540	640			
	640	740			
	740	840			
840	940				
TCH09 Double slider	160	5	280	500	
	260		380		
	360		480		
	460		580		
	560		680		
	660	780			
	160	10	380	930	
	260		480		
	360		580		
	460		680		
	560		780		
	660	880			
	TCH10 Single slider	160	5	280	250
		260		380	
		360		480	
460		580			
560		680			
660		780			
160		10	380	500	
260			480		
360			580		
460			680		
560			780		
660		880			
160		20	480	1 000	
260			580		
360			680		
460	780				
560	880				
660	980				
TCH10 Double slider	180	5	320	500	
	280		420		
	380		520		
	480		620		
	580		720		
	680	820			
	180	10	420	930	
	280		520		
	380		620		
	480		720		
	580		820		
	680	920			
	180	20	520	1 000	
	280		620		
	380		720		
480	820				
580	920				

Note: If you need to operate the Toughcarrier near the critical speed or in excess of the maximum speed in the table, please consult NSK.

C-2-4. 5 Rigidity

Rigidity of rail

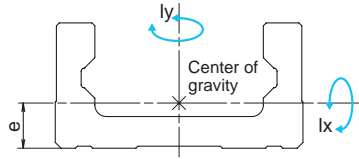

Model no.	Geometrical moment of inertia ¹⁾ (mm ⁴)		Center of gravity (mm)	Mass (kg/100mm)
	l _x	l _y	e	w
TCH06	6.47	36.2	10.6	0.6
TCH09	28.4	162	15.7	1.32
TCH10	46	283	17.2	1.73

◆ Rigidity in radial direction

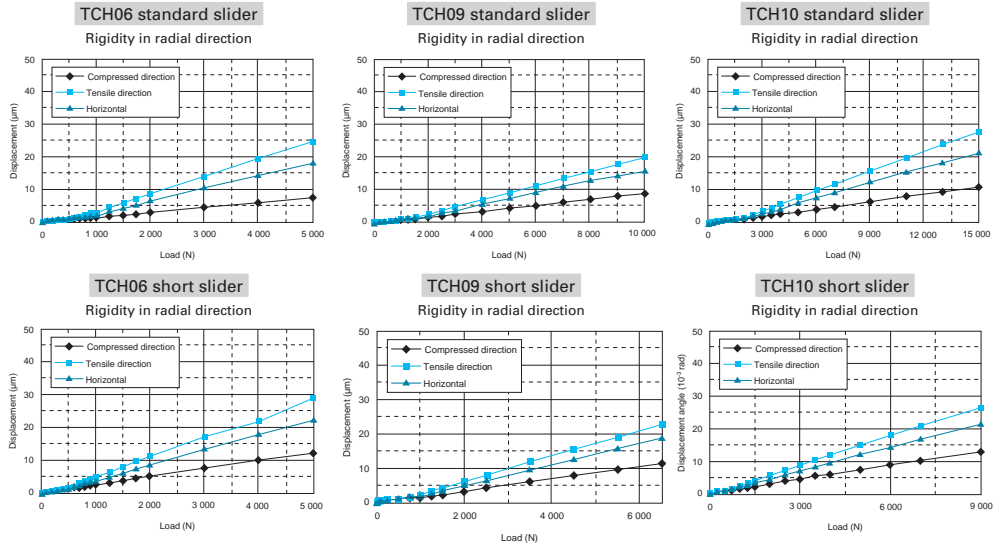

◆ Moment in radial direction

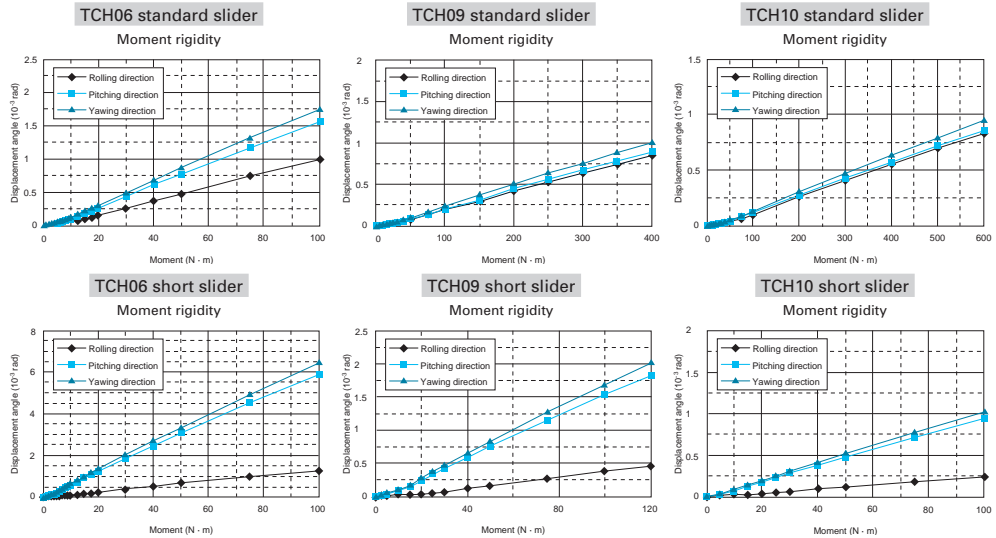

C-2-4. 6 Basic Load Rating

◆ Basic load rating for TCH series

Standard slider

Model no.	Lead l (mm)	Shaft dia. d (mm)	Basic dynamic load rating (N)			Basic static load rating (N)		Support bearing limit load (N)
			Ball screw C_a	Linear guide C	Support bearings C_a	Ball screw C_{0a}	Linear guide C_0	
TCH06	5	$\phi 12$	3 760	20 900	6 600	6 310	45 000	2 700
	10		2 420			3 790		
	20		2 420			3 790		
TCH09	5	$\phi 15$	7 070	44 900	8 800	12 800	96 900	5 090
	10		7 070			12 800		
	20		4 560			7 730		
TCH10	10	$\phi 20$	11 000	62 400	9 600	21 100	132 000	5 670
	20		7 060			12 700		

Short slider

Model no.	Lead l (mm)	Shaft dia. d (mm)	Basic dynamic load rating (N)			Basic static load rating (N)		Support bearing limit load (N)
			Ball screw C_a	Linear guide C	Support bearings C_a	Ball screw C_{0a}	Linear guide C_0	
TCH06	5	$\phi 12$	3 760	12 200	6 600	6 310	22 500	2 700
	10		2 260			3 780		
TCH09	5	$\phi 15$	7 100	27 900	8 800	13 000	52 500	5 090
	10		7 060			12 700		
	20		4 560			7 750		
TCH10	10	$\phi 20$	10 900	38 700	9 600	21 700	71 500	5 670
	20		7 060			12 700		

- Basic dynamic and static load ratings indicate values for one slider.
- Basic dynamic load rating of linear guide is a load that allows for a 50-km rating fatigue life and is a vertical and constant load on the ball mounting surface.
- Basic dynamic load rating of ball screw is load in the axial direction that allows 90% of ball screws of a group of the same Toughcarriers to rotate 1 million revolutions under the same condition without causing flaking by rolling contact fatigue.
- Basic dynamic load rating of support bearings is load that allows 1 million revolutions under the same condition.
- Basic static load rating is load that results in combined permanent deformations at contact points of rolling elements and rolling surfaces of respective parts at a diameter of 0.01%.

◆ Basic static moment load of linear guide

Standard slider

Model no.	Slider	Basic static moment load (N·m)		
		Rolling M_{RO}	Pitching M_{PO}	Yawing M_{YO}
TCH06	Single	800	340	340
TCH09	Single	2 510	1 340	1 340
TCH10	Single	3 980	2 150	2 150

Short slider

Model no.	Slider	Basic static moment load (N·m)		
		Rolling M_{RO}	Pitching M_{PO}	Yawing M_{YO}
TCH06	Single	400	85	85
TCH09	Single	1 350	390	390
TCH10	Single	2 150	630	630

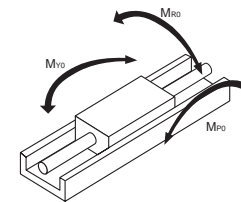

M_{RO} : Rolling moment
 M_{PO} : Pitching moment
 M_{YO} : Yawing moment

C-2-4. 7 Estimation of Life Expectancy

(1) Life of linear guide for Toughcarrier

Study the load to be applied to the linear guide of Toughcarrier (Fig. 1). The equivalent load (Fe) is determined by substituting the load for equation 1) (Eq. 2) or 2') for tightly coupled double slider type).

● For single slider

$$Fe = Y_H F_H + Y_V F_V + Y_R \epsilon_R M_R + Y_P \epsilon_P M_P + Y_Y \epsilon_Y M_Y \dots\dots\dots 1)$$

● For double slider

For double sliders, calculation of the load applied to each slider is required.

Dynamic equivalent load is only for rolling moment.

This is the same procedure as for linear guide selection where two sliders are installed in a rail. Check the mean load for each slider, and calculate shortest life becomes the life of linear guide.

When lateral direction (F_H) and vertical direction (F_V) loads are applied to the center of the coordinate in Fig. 1,

$$F_{HA} = \frac{F_H}{2} + \frac{M_Y}{\ell}, F_{VA} = \frac{F_V}{2} + \frac{M_P}{\ell}$$

$$F_{HB} = \frac{F_H}{2} - \frac{M_Y}{\ell}, F_{VB} = \frac{F_V}{2} - \frac{M_P}{\ell}$$

[Slider A]

$$Fe_A = Y_H \cdot F_{HA} + Y_V \cdot F_{VA} + Y_R \epsilon_R \frac{M_R}{2} \dots\dots\dots 2)$$

$$= Y_H \left(\frac{F_H}{2} + \frac{M_Y}{\ell} \right) + Y_V \left(\frac{F_V}{2} + \frac{M_P}{\ell} \right) + Y_R \epsilon_R \frac{M_R}{2}$$

[Slider B]

$$Fe_B = Y_H \cdot F_{HB} + Y_V \cdot F_{VB} + Y_R \epsilon_R \frac{M_R}{2} \dots\dots\dots 2')$$

$$= Y_H \left(\frac{F_H}{2} - \frac{M_Y}{\ell} \right) + Y_V \left(\frac{F_V}{2} - \frac{M_P}{\ell} \right) + Y_R \epsilon_R \frac{M_R}{2}$$

- F_H : Lateral direction load acting on the slider (N)
- F_V : Vertical direction load acting on the slider (N)
- M_R : Rolling moment acting on the slider (N · m)
- M_P : Pitching moment acting on the slider (N · m)
- M_Y : Yawing moment acting on the slider (N · m)
- ε_R : Dynamic equivalent coefficient to rolling moment
- ε_P : Dynamic equivalent coefficient to pitching moment
- ε_Y : Dynamic equivalent coefficient to yawing moment
- ℓ : Sliders span (m)

*For dynamic equivalent coefficient, see table 1.

Y_H, Y_V, Y_R, Y_P, Y_Y: 1.0 or 0.5

At equations 1), 2) and 2') for obtaining equivalent load Fe, the maximum value of Y in the values for each equation is assumed to be 1.0. For others it is assumed to be 0.5.

Fig.1 Direction of load

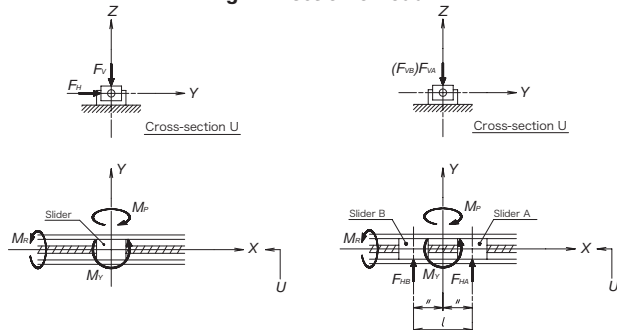
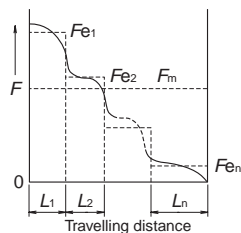

Fig. 2 Stepwise Fluctuating Load



If the loads acting on the slider fluctuate (in general, M_p and M_v may fluctuate with the acceleration/deceleration of slider), the mean effective load is determined by Eq. 3).

- Travelling distance under the equivalent load Fe₁ : L₁
- Travelling distance under the equivalent load Fe₂ : L₂
-
- Travelling distance under the equivalent load Fe_n : L_n

Mean effective load Fm is calculated by the following equation.

$$Fm = \sqrt[10]{\frac{1}{L} (Fe_1^{10} \cdot L_1 + Fe_2^{10} \cdot L_2 + \dots + Fe_n^{10} \cdot L_n) \dots 3)$$

Fm: Mean effective load of fluctuating loads (N)
L : Total travelling distance (mm)

The life of linear guide for Toughcarrier is determined by Eq. 4).

$$L = 50 \times \left(\frac{C}{f_w \cdot Fm} \right)^3 \dots\dots\dots 4)$$

- L : Life of linear guide (km)
- C : Basic dynamic load rating of linear guide (N)
- Fm: Mean effective load acting on linear guide (N)
- f_w : Load coefficient (see table 2)

When the estimated life does not meet clear the required life, the life of the linear guide is calculated again after following measures are taken,

- 1: Change from single slider type to double slider type.
- 2: Use a larger Toughcarrier.

(2) Life of Ball Screw (Support Bearing)

The mean effective load is determined from the axial load.

Axial direction mean effective load Fm

$$Fm = \sqrt[3]{\frac{1}{L} (Fe_1^3 \cdot L_1 + Fe_2^3 \cdot L_2 + \dots + Fe_n^3 \cdot L_n) \dots 5)$$

The life of ball screw is determined by Eq. 6).

$$L = \ell \times \left(\frac{C_a}{f_w \cdot Fm} \right)^3 \times 10^6 \dots\dots\dots 6)$$

- ℓ : Ball screw lead (mm)
- L : Life of ball screw (mm)
- C_a : Basic dynamic load rating of ball screw (N)
- Fm: Mean effective load acting on ball screw (N)
- f_w : Load factor (see table 2)

The life of a support bearing is calculated by Eq. 6). If the life of ball screw/support bearing does not meet the required life, use a larger size Toughcarrier. After applying the calculations mentioned above, selection of the Toughcarrier is completed.

Table 2 Value of load factor

Operating conditions	Load factor f _w
At smooth operation with no mechanical shock	1.0 ~ 1.2
At normal operation	1.2 ~ 1.5
At operation with mechanical shock and vibration	1.5 ~ 3.0

*When the bottom of rail is not fastened, the load factor is 1.5 or greater.

Table 1 Dynamic equivalent coefficient

	TCH06			TCH09			TCH10		
	Rolling	Pitching	Yawing	Rolling	Pitching	Yawing	Rolling	Pitching	Yawing
Standard slider	56	93	93	39	51	51	33	44	44
Short slider	56	186	186	39	95	95	33	80	80

C-2-4. 8 Example of Life Estimation

Example of life estimation for Toughcarrier

Example-1

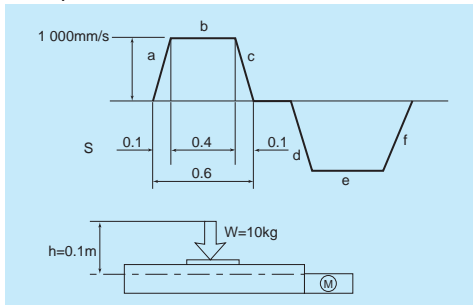

1. Use condition

- Stroke : 500 mm
- Maximum speed : 1 000 mm/s
- Load mass : $W = 10$ kg
- Acceleration : 9.80 m/s²
- Setting position : Horizontal
- Operating profile : See figure to above

2. Selection of model number (interim selection)
First, select a greater ball screw lead as the maximum speed is 1 000 mm/s.
The interim selection is TCH06050H20K00, a single slider specification TCH06 that has 500 mm stroke, as the stroke is 500 mm.

3. Calculation

3-1. Linear guide

3-1-1. Fatigue life: Multiply the result of Eq. 1) by the dynamic equivalent coefficient (Table 1 single slider) to convert the load volume. From operation profile in the above figure, the acceleration is 10 m/s².

- i) Constant speed $Fe_1 = Y_V \cdot F_V = Y_V \cdot W \cdot g$
 $= 1 \cdot 10 \cdot 9.8 = 98$ N
- ii) Accelerating $Fe_2 = Y_V \cdot F_V + Y_P \cdot \epsilon_P \cdot M_P$
 $= Y_V \cdot W \cdot g + Y_P \cdot \epsilon_P \cdot hW\alpha$
 $= 0.5 \cdot 10 \cdot 9.8 + 1.93 \cdot 0.1 \cdot 10 \cdot 10$
 $= 979$ N
- iii) Decelerating $Fe_3 = Y_V \cdot F_V + Y_P \cdot \epsilon_P \cdot M_P$
 $= Y_V \cdot W \cdot g + Y_P \cdot \epsilon_P \cdot hW\alpha$
 $= 0.5 \cdot 10 \cdot 9.8 + 1.93 \cdot 0.1 \cdot 10 \cdot 10$
 $= 979$ N

Mean effective load Fm

$$Fm = \sqrt[3]{\frac{1}{L} (Fe_1^3 \cdot L_1 + Fe_2^3 \cdot L_2 + Fe_3^3 \cdot L_3)}$$

$$= \sqrt[3]{\frac{1}{500} (98^3 \cdot 400 + 979^3 \cdot 50 + 979^3 \cdot 50)}$$

$$= 605$$
 N

$$L = 50 \times \left(\frac{C}{f_w \cdot Fm} \right)^{\frac{10}{3}}$$

$$= 50 \times \left(\frac{20\,900}{1.2 \cdot 605} \right)^{\frac{10}{3}}$$

$$= 3.65 \times 10^6$$
 km

3-1-2. Static safety factor: Divide the basic static load rating by the maximum load.

$$F_s = \frac{C_0}{Fe} = \frac{C_0}{Fe_2} = \frac{45\,000}{979} = 45.9$$

3-2. Ball screw

3-2-1. Fatigue life: Obtain the axial load of each stage of operation referring to the operation profile, and then calculate the mean load.

By the process above,

- i) Constant speed $Fe_1 = \mu \cdot W \cdot g = 0.01 \cdot 10 \cdot 9.8 = 0.98$ N
- ii) Accelerating $Fe_2 = Fe_1 + W \cdot \alpha = 0.98 + 10 \cdot 10 = 101$ N
- iii) Decelerating $Fe_3 = Fe_1 + W \cdot \alpha = 0.98 - 10 \cdot 10 = 99$ N

Axial mean effective load

$$Fm = \sqrt[3]{\frac{1}{L} (Fe_1^3 \cdot L_1 + Fe_2^3 \cdot L_2 + Fe_3^3 \cdot L_3)}$$

$$= \sqrt[3]{\frac{1}{500} (0.98^3 \cdot 400 + 101^3 \cdot 50 + 99^3 \cdot 50)}$$

$$= 59$$
 N

$$L = \ell \times \left(\frac{C_a}{f_w \cdot Fm} \right)^3 \times 10^6$$

$$= 20 \times \left(\frac{2\,260}{1.2 \cdot 59} \right)^3 \times 10^6$$

$$= 6.50 \times 10^5$$
 km

3-2-2. Static safety factor: Divide the basic static load rating by the maximum axial load.

$$F_s = \frac{C_{0a}}{Fe} = \frac{C_{0a}}{Fe_2} = \frac{3\,780}{101} = 37.4$$

3-3. Support bearings

3-3-1. Fatigue life: Use the axial load $Fm = 59$ N that is the result of the calculation in 3-2-1, above.

$$L = \ell \times \left(\frac{C_a}{f_w \cdot Fm} \right)^3 \times 10^6$$

$$= 20 \times \left(\frac{6\,600}{1.2 \cdot 59} \right)^3 \times 10^6$$

$$= 1.62 \times 10^7$$
 km

3-3-2. Static safety factor: Divide the limit load by the maximum axial load.

$$F_s = \frac{C_{0a}}{Fe} = \frac{C_{0a}}{Fe_2} = \frac{2\,730}{101} = 26.7$$

3-4. Result

TCH06050H20K00	Linear guide	Ball screw	Support bearings
Fatigue life	3.65 × 10 ⁶ km	6.50 × 10 ⁵ km	1.62 × 10 ⁷ km
Static safety factor	45.9	37.4	26.7

Example of life estimation

Example-2

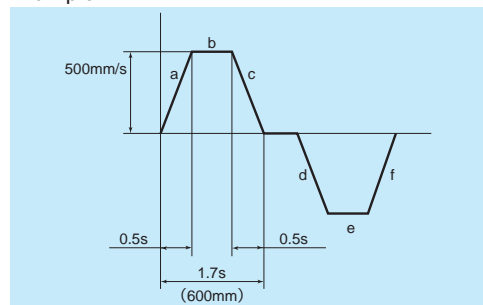

1. Use condition

- Stroke : 600 mm
- Maximum speed : 500 mm/s
- Load mass : $W = 20$ kg
- Acceleration : 9.8 m/s²
- Setting position : Vertical
- Operating profile : See figure to above

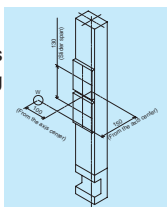

2. Selection of model number (interim selection)
 Select a 10 mm lead ball screw as the maximum speed is 500 mm/s.
 The interim selection is TCH09067H10D00 (double slider specification) from the stroke and the vertical setting position.

3. Calculation

3-1. Linear guide

3-1-1. Fatigue life: Multiply the result of Eq. 2) and 2') by the dynamic equivalent coefficient (Table 1 double slider) to convert the load volume. From operation profile in the above figure, the acceleration is 1 m/s². The interim slider span is 0.13.

Under this condition,
 $F_H = 0, F_V = 0, M_R = 0$

in Eq., and both sliders have the same load with different direction.

i) Constant speed

$$F_{e1} = Y_H \cdot \frac{M_V}{\ell} + Y_V \cdot \frac{M_P}{\ell}$$

$$= 0.5 \cdot \frac{0.1 \cdot 20 \cdot 9.8}{0.13} + 1.0 \cdot \frac{0.15 \cdot 20 \cdot 9.8}{0.13}$$

$$= 302 \text{ N}$$

ii) Accelerating

$$F_{e2} = Y_H \cdot \frac{M_V}{\ell} + Y_V \cdot \frac{M_P}{\ell}$$

$$= 0.5 \cdot \frac{0.1 \cdot 20 \cdot (9.8 + 1.0)}{0.13} + 1.0 \cdot \frac{0.15 \cdot 20 \cdot (9.8 + 1.0)}{0.13}$$

$$= 333 \text{ N}$$

iii) Decelerating

$$F_{e3} = Y_H \cdot \frac{M_V}{\ell} + Y_V \cdot \frac{M_P}{\ell}$$

$$= 0.5 \cdot \frac{0.1 \cdot 20 \cdot (9.8 - 1.0)}{0.13} + 1.0 \cdot \frac{0.15 \cdot 20 \cdot (9.8 - 1.0)}{0.13}$$

$$= 271 \text{ N}$$

Mean effective load F_m

$$F_m = \sqrt[3]{\frac{1}{L} (F_{e1}^{10} \cdot L_1 + F_{e2}^{10} \cdot L_2 + F_{e3}^{10} \cdot L_3)}$$

$$= \sqrt[3]{\frac{1}{600} (302^{10} \cdot 350 + 333^{10} \cdot 125 + 271^{10} \cdot 125)}$$

$$= 304 \text{ N}$$

$$L = 50 \times \left(\frac{C}{f_w \cdot F_m} \right)^{\frac{10}{3}}$$

$$= 50 \times \left(\frac{44\,900}{1.2 \cdot 304} \right)^{\frac{10}{3}}$$

$$= 4.63 \times 10^8 \text{ km}$$

3-1-2. Static safety factor: Divide the basic static load rating by the maximum load.

$$F_s = \frac{C_0}{F_e} = \frac{C_0}{F_{e2}} = \frac{96\,900}{333} = 290$$

3-2. Ball screw

3-2-1. Fatigue life: Obtain the axial load of each stage of operation referring to the operation profile, and then calculate the mean load.

i) Constant speed

$$F_{e1} = W \cdot g = 20 \cdot 9.8 = 196 \text{ N}$$

ii) Accelerating

$$F_{e2} = F_{e1} + W \cdot \alpha = 196 + 20 \cdot 1.0 = 216 \text{ N}$$

iii) Decelerating

$$F_{e3} = F_{e1} - W \cdot \alpha = 196 - 20 \cdot 1.0 = 176 \text{ N}$$

Axial mean effective load F_m

$$F_m = \sqrt[3]{\frac{1}{L} (F_{e1}^{10} \cdot L_1 + F_{e2}^{10} \cdot L_2 + F_{e3}^{10} \cdot L_3)}$$

$$= \sqrt[3]{\frac{1}{600} (196^{10} \cdot 350 + 216^{10} \cdot 125 + 176^{10} \cdot 125)}$$

$$= 197 \text{ N}$$

$$L = \ell \times \left(\frac{C_a}{f_w \cdot F_m} \right)^3 \times 10^6$$

$$= 10 \times \left(\frac{7\,060}{1.2 \cdot 197} \right)^3 \times 10^6$$

$$= 2.66 \times 10^5 \text{ km}$$

3-2-2. Static safety factor: Divide the basic static load rating by the maximum axial load.

$$F_s = \frac{C_{0a}}{F_e} = \frac{C_{0a}}{F_{e2}} = \frac{12\,700}{216} = 58.7$$

3-3. Support bearings

3-3-1. Fatigue life: Use the axial load $F_m = 197$ N that is the result of the calculation in 3-2-1, above.

$$L = \ell \times \left(\frac{C_a}{f_w \cdot F_m} \right)^3 \times 10^6$$

$$= 10 \times \left(\frac{8\,800}{1.2 \cdot 197} \right)^3 \times 10^6$$

$$= 5.15 \times 10^5 \text{ km}$$

3-3-2. Static safety factor: Divide the limit load by the maximum axial load.

$$F_s = \frac{C_{0a}}{F_e} = \frac{C_{0a}}{F_{e2}} = \frac{5\,090}{216} = 23.5$$

3-4. Result

TCH09067H10D00	Linear guide	Ball screw	Support bearings
Fatigue life	4.63 × 10 ⁸ km	2.66 × 10 ⁵ km	5.15 × 10 ⁵ km
Static safety factor	290	58.7	23.5

C-2-5. 2 TCH09 Series

◆ TCH09 Standard Slider Specifications (with pin holes)

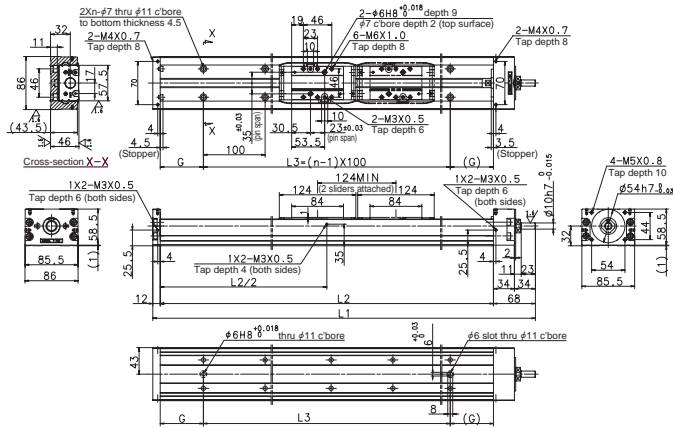

Toughcarrier dynamic torque specifications Unit: N · cm

Model no.	Slider specifications	Ball screw lead (mm)	Accuracy grade	
			High grade	Precision grade
TCH09	Single standard slider	5	2.8 ~ 7.7	4.2 ~ 12.8
		10	3.7 ~ 9.5	4.5 ~ 15.1
		20	3.7 ~ 12.6	5.1 ~ 17.9
	Double standard sliders	5	3.2 ~ 8.7	4.5 ~ 14.1
		10	4.2 ~ 12.6	5.1 ~ 17.9
		20	5.7 ~ 18.9	6.3 ~ 23.3

◆ TCH09 Short Slider Specifications (with pin holes)

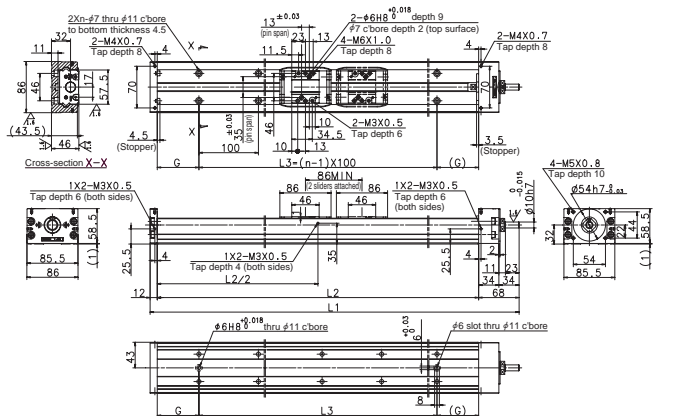

Toughcarrier dynamic torque specifications Unit: N · cm

Model no.	Slider specifications	Ball screw lead (mm)	Accuracy grade	
			High grade	Precision grade
TCH09	Single short slider	5	2.0 ~ 6.9	3.5 ~ 12.0
		10	2.9 ~ 8.7	3.8 ~ 14.3
		20	2.9 ~ 11.8	4.3 ~ 17.1
	Double short sliders	5	2.5 ~ 7.9	3.8 ~ 13.3
		10	3.4 ~ 11.8	4.3 ~ 17.1
		20	4.9 ~ 18.1	5.5 ~ 22.6

TCH09 Standard Slider Specifications (Single)

Reference number	Nominal stroke (mm)	Stroke limit (mm)	Ball screw lead (mm)	Body length (mm)				No. of mounting holes n	Inertia × 10 ⁶ (kg · m ²)	Mass (kg)
				L ₁	L ₂	L ₃	G			
*TCH09010H05K00 (01)	100	108	5	320	240	100	70	2	9.13	6.5
TCH09010H10K00 (01)			10						11.0	
*TCH09010H20K00 (01)			20						18.6	
TCH09020H05K00 (01)	200	208	5	420	340	200	70	3	14.2	7.9
TCH09020H10K00 (01)			10						16.0	
TCH09020H20K00 (01)			20						23.6	
TCH09030H05K00 (01)	300	308	5	520	440	300	70	4	18.1	9.4
TCH09030H10K00 (01)			10						19.9	
TCH09030H20K00 (01)			20						27.5	
TCH09040H05K00 (01)	400	408	5	620	540	400	70	5	21.9	10.8
TCH09040H10K00 (01)			10						23.8	
TCH09040H20K00 (01)			20						31.4	
TCH09050H05K00 (01)	500	508	5	720	640	500	70	6	25.9	12.3
TCH09050H10K00 (01)			10						27.7	
TCH09050H20K00 (01)			20						35.3	
TCH09060H05K00 (01)	600	608	5	820	740	600	70	7	29.4	13.6
TCH09060H10K00 (01)			10						31.3	
TCH09060H20K00 (01)			20						38.9	
TCH09070H05K00 (01)	700	708	5	920	840	700	70	8	33.5	15.0
TCH09070H10K00 (01)			10						35.4	
TCH09070H20K00 (01)			20						43.0	
TCH09080H05K00 (01)	800	808	5	1 020	940	800	70	9	37.4	16.4
TCH09080H10K00 (01)			10						39.3	
TCH09080H20K00 (01)			20						46.9	

Items marked with * are unavailable for upside-down operation.

TCH09 Standard Slider Specifications (Double)

Reference number	Nominal stroke (mm)	Stroke limit (mm)	Ball screw lead (mm)	Body length (mm)				No. of mounting holes n	Inertia × 10 ⁶ (kg · m ²)	Mass (kg)
				L ₁	L ₂	L ₃	G			
*TCH09017H05D00 (01)	170	184	5	520	440	300	70	4	19.47	10.3
*TCH09017H10D00 (01)			10						22.89	
*TCH09027H05D00 (01)	270	284	5	620	540	400	70	5	23.35	11.7
*TCH09027H10D00 (01)			10						26.77	
TCH09037H05D00 (01)	370	384	5	720	640	500	70	6	27.22	13.2
TCH09037H10D00 (01)			10						30.64	
TCH09047H10D00 (01)	470	484	10	820	740	600	70	7	34.55	14.5
TCH09047H20D00 (01)			20						48.24	
TCH09067H10D00 (01)	670	684	10	1 020	940	800	70	9	42.27	17.3
TCH09067H20D00 (01)			20						55.96	

Items marked with * are unavailable for upside-down operation.

TCH09 Short Slider Specifications (Single)

Reference number	Nominal stroke (mm)	Stroke limit (mm)	Ball screw lead (mm)	Body length (mm)				No. of mounting holes n	Inertia × 10 ⁶ (kg · m ²)	Mass (kg)
				L ₁	L ₂	L ₃	G			
*TCH09014H05A00 (01)	140	146	5	320	240	100	70	2	8.9	6.1
*TCH09014H10A00 (01)			10						10.1	
*TCH09014H20A00 (01)			20						14.6	
TCH09024H05A00 (01)	240	246	5	420	340	200	70	3	13.9	7.5
TCH09024H10A00 (01)			10						15.1	
TCH09024H20A00 (01)			20						19.6	
TCH09034H05A00 (01)	340	346	5	520	440	300	70	4	17.8	9.0
TCH09034H10A00 (01)			10						18.9	
TCH09034H20A00 (01)			20						23.5	
TCH09044H05A00 (01)	440	446	5	620	540	400	70	5	21.7	10.4
TCH09044H10A00 (01)			10						22.8	
TCH09044H20A00 (01)			20						27.4	
TCH09054H05A00 (01)	540	546	5	720	640	500	70	6	25.6	11.9
TCH09054H10A00 (01)			10						26.7	
TCH09054H20A00 (01)			20						31.3	
TCH09064H05A00 (01)	640	646	5	820	740	600	70	7	29.2	13.2
TCH09064H10A00 (01)			10						30.3	
TCH09064H20A00 (01)			20						34.9	
TCH09074H05A00 (01)	740	746	5	920	840	700	70	8	33.3	14.6
TCH09074H10A00 (01)			10						34.4	
TCH09074H20A00 (01)			20						39.9	
TCH09084H05A00 (01)	840	846	5	1 020	940	800	70	9	37.2	16.0
TCH09084H10A00 (01)			10						38.3	
TCH09084H20A00 (01)			20						42.8	

Items marked with * are unavailable for upside-down operation.

TCH09 Short Slider Specifications (Double)

Reference number	Nominal stroke (mm)	Stroke limit (mm)	Ball screw lead (mm)	Body length (mm)				No. of mounting holes n	Inertia × 10 ⁶ (kg · m ²)	Mass (kg)
				L ₁	L ₂	L ₃	G			
TCH09025H05B00 (01)	250	260	5	520	440	300	70	4	18.96	9.5
TCH09025H10B00 (01)			10						20.86	
TCH09035H05B00 (01)	350	360	5	620	540	400	70	5	22.84	10.9
TCH09035H10B00 (01)			10						24.74	
TCH09045H05B00 (01)	450	460	5	720	640	500	70	6	26.71	12.4
TCH09045H10B00 (01)			10						28.61	
TCH09055H10B00 (01)	550	560	10	820	740	600	70	7	32.52	13.7
TCH09055H20B00 (01)			20						40.13	
TCH09075H10B00 (01)	750	760	10	1 020	940	800	70	9	40.24	16.5
TCH09075H20B00 (01)			20						47.85	

C-2-5. 3 TCH 10 Series

◆ TCH10 Standard Slider Specifications (with pin holes)

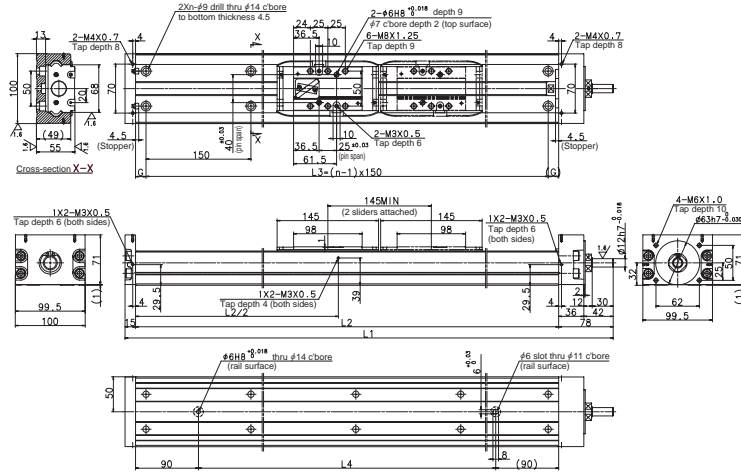

Toughcarrier dynamic torque specifications Unit: N · cm

Model no.	Slider specifications	Ball screw lead (mm)	Accuracy grade	
			High grade	Precision grade
TCH10	Single standard slider	10	3.5 ~ 12.3	3.7 ~ 21.2
		20	4.1 ~ 16.6	4.3 ~ 25.5
	Double standard sliders	10	4.1 ~ 16.6	4.3 ~ 25.5
		20	5.4 ~ 25.2	5.6 ~ 34.1

◆ TCH10 Short Slider Specifications (with pin holes)

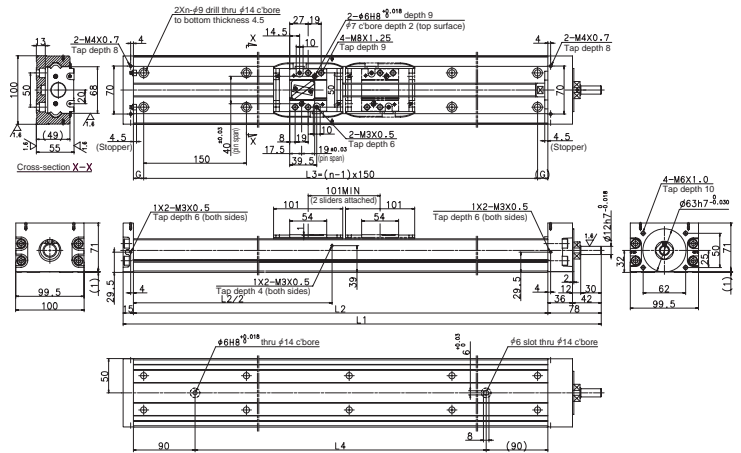

Toughcarrier dynamic torque specifications Unit: N · cm

Model no.	Slider specifications	Ball screw lead (mm)	Accuracy grade	
			High grade	Precision grade
TCH10	Single short slider	10	3.6 ~ 11.7	3.8 ~ 20.5
		20	4.4 ~ 15.4	4.6 ~ 24.2
	Double short sliders	10	4.4 ~ 15.4	4.6 ~ 24.2
		20	6.0 ~ 22.7	6.2 ~ 31.5

TCH10 Standard Slider Specifications (Single)

Reference number	Nominal stroke (mm)	Stroke limit (mm)	Ball screw lead (mm)	Body length (mm)					No. of mounting holes <i>n</i>	Inertia × 10 ⁶ (kg · m ²)	Mass (kg)
				L ₁	L ₂	L ₃	L ₄	G			
*TCH10010H10K00 (01)	100	126	10	373	280	150	100	65	2	42.72	9.6
*TCH10010H20K00 (01)	100	126	20	373	280	150	100	65	2	58.52	9.6
TCH10020H10K00 (01)	200	226	10	473	380	300	200	40	3	54.97	11.5
TCH10020H20K00 (01)	200	226	20	473	380	300	200	40	3	65.62	11.5
TCH10030H10K00 (01)	300	326	10	573	480	450	300	15	4	67.27	13.5
TCH10030H20K00 (01)	300	326	20	573	480	450	300	15	4	77.87	13.5
TCH10040H10K00 (01)	400	426	10	673	580	450	400	65	4	79.47	15.4
TCH10040H20K00 (01)	400	426	20	673	580	450	400	65	4	90.12	15.4
TCH10050H10K00 (01)	500	526	10	773	680	600	500	40	5	91.72	17.4
TCH10050H20K00 (01)	500	526	20	773	680	600	500	40	5	102.37	17.4
TCH10060H10K00 (01)	600	626	10	873	780	750	600	15	6	104.02	19.3
TCH10060H20K00 (01)	600	626	20	873	780	750	600	15	6	114.67	19.3
TCH10070H10K00 (01)	700	726	10	973	880	750	700	65	6	116.22	21.2
TCH10070H20K00 (01)	700	726	20	973	880	750	700	65	6	126.87	21.2
TCH10080H10K00 (01)	800	826	10	1 073	980	900	800	40	7	128.52	23.2
TCH10080H20K00 (01)	800	826	20	1 073	980	900	800	40	7	139.17	23.2
TCH10090H10K00 (01)	900	926	10	1 173	1 080	1 050	900	15	8	140.70	25.2
TCH10090H20K00 (01)	900	926	20	1 173	1 080	1 050	900	15	8	151.35	25.2
TCH10100H10K00 (01)	1 000	1 026	10	1 273	1 180	1 050	1 000	65	8	152.94	27.1
TCH10100H20K00 (01)	1 000	1 026	20	1 273	1 180	1 050	1 000	65	8	163.59	27.1
TCH10110H10K00 (01)	1 100	1 126	10	1 373	1 280	1 200	1 100	40	9	165.19	29.1
TCH10110H20K00 (01)	1 100	1 126	20	1 373	1 280	1 200	1 100	40	9	175.84	29.1
TCH10120H10K00 (01)	1 200	1 226	10	1 473	1 380	1 350	1 200	15	10	177.43	31.1
TCH10120H20K00 (01)	1 200	1 226	20	1 473	1 380	1 350	1 200	15	10	188.08	31.1

TCH10 Standard Slider Specifications (Double) Items marked with * are unavailable for upside-down operation

Reference number	Nominal stroke (mm)	Stroke limit (mm)	Ball screw lead (mm)	Body length (mm)					No. of mounting holes <i>n</i>	Inertia × 10 ⁶ (kg · m ²)	Mass (kg)
				L ₁	L ₂	L ₃	L ₄	G			
*TCH10027H10D00 (01)	270	281	10	673	580	450	400	65	4	83.02	16.8
*TCH10027H20D00 (01)	270	281	20	673	580	450	400	65	4	104.31	16.8
*TCH10037H10D00 (01)	370	381	10	773	680	600	500	40	5	95.27	18.8
*TCH10037H20D00 (01)	370	381	20	773	680	600	500	40	5	116.56	18.8
TCH10047H10D00 (01)	470	481	10	873	780	750	600	15	6	107.57	20.7
TCH10047H20D00 (01)	470	481	20	873	780	750	600	15	6	128.86	20.7
TCH10057H10D00 (01)	570	581	10	973	880	750	700	65	6	119.77	22.6
TCH10057H20D00 (01)	570	581	20	973	880	750	700	65	6	141.06	22.6
TCH10067H10D00 (01)	670	681	10	1 073	980	900	800	40	7	132.07	24.6
TCH10067H20D00 (01)	670	681	20	1 073	980	900	800	40	7	153.36	24.6
TCH10077H20D00 (01)	770	781	20	1 173	1 080	1 050	900	15	8	168.54	26.6
TCH10087H20D00 (01)	870	881	20	1 273	1 180	1 050	1 000	65	8	177.78	28.5
TCH10097H20D00 (01)	970	981	20	1 373	1 280	1 200	1 100	40	9	190.03	30.5
TCH10107H20D00 (01)	1 070	1 081	20	1 473	1 380	1 350	1 200	15	10	202.27	32.5

TCH10 Short Slider Specifications (Single) Items marked with * are unavailable for upside-down operation

Reference number	Nominal stroke (mm)	Stroke limit (mm)	Ball screw lead (mm)	Body length (mm)					No. of mounting holes <i>n</i>	Inertia × 10 ⁶ (kg · m ²)	Mass (kg)
				L ₁	L ₂	L ₃	L ₄	G			
*TCH10016H10A00 (01)	160	170	10	373	280	150	100	65	2	41.20	8.9
*TCH10016H20A00 (01)	160	170	20	373	280	150	100	65	2	59.81	8.9
TCH10026H10A00 (01)	260	270	10	473	380	300	200	40	3	53.45	10.9
TCH10026H20A00 (01)	260	270	20	473	380	300	200	40	3	59.54	10.9
TCH10036H10A00 (01)	360	370	10	573	480	450	300	15	4	65.70	12.8
TCH10036H20A00 (01)	360	370	20	573	480	450	300	15	4	71.79	12.8
TCH10046H10A00 (01)	460	470	10	673	580	450	400	65	4	77.95	14.8
TCH10046H20A00 (01)	460	470	20	673	580	450	400	65	4	84.04	14.8
TCH10056H10A00 (01)	560	570	10	773	680	600	500	40	5	90.20	16.7
TCH10056H20A00 (01)	560	570	20	773	680	600	500	40	5	96.29	16.7
TCH10066H10A00 (01)	660	670	10	873	780	750	600	15	6	102.50	18.6
TCH10066H20A00 (01)	660	670	20	873	780	750	600	15	6	108.59	18.6
TCH10076H10A00 (01)	760	770	10	973	880	750	700	65	6	114.70	20.6
TCH10076H20A00 (01)	760	770	20	973	880	750	700	65	6	120.79	20.6
TCH10086H10A00 (01)	860	870	10	1 073	980	900	800	40	7	127.00	22.6
TCH10086H20A00 (01)	860	870	20	1 073	980	900	800	40	7	133.09	22.6
TCH10096H10A00 (01)	960	970	10	1 173	1 080	1 050	900	15	8	139.18	24.5
TCH10096H20A00 (01)	960	970	20	1 173	1 080	1 050	900	15	8	145.27	24.5
TCH10106H10A00 (01)	1 060	1 070	10	1 273	1 180	1 050	1 000	65	8	151.42	26.5
TCH10106H20A00 (01)	1 060	1 070	20	1 273	1 180	1 050	1 000	65	8	157.51	26.5
TCH10116H10A00 (01)	1 160	1 170	10	1 373	1 280	1 200	1 100	40	9	163.67	28.4
TCH10116H20A00 (01)	1 160	1 170	20	1 373	1 280	1 200	1 100	40	9	169.76	28.4
TCH10126H10A00 (01)	1 260	1 270	10	1 473	1 380	1 350	1 200	15	10	175.91	30.4
TCH10126H20A00 (01)	1 260	1 270	20	1 473	1 380	1 350	1 200	15	10	182.00	30.4

TCH10 Short Slider Specifications (Double) Items marked with * are unavailable for upside-down operation

Reference number	Nominal stroke (mm)	Stroke limit (mm)	Ball screw lead (mm)	Body length (mm)					No. of mounting holes <i>n</i>	Inertia × 10 ⁶ (kg · m ²)	Mass (kg)
				L ₁	L ₂	L ₃	L ₄	G			
TCH10036H10B00 (01)	360	369	10	673	580	450	400	65	4	79.97	15.6
TCH10036H20B00 (01)	360	369	20	673	580	450	400	65	4	92.14	15.6
TCH10046H10B00 (01)	460	469	10	773	680	600	500	40	5	92.22	17.5
TCH10046H20B00 (01)	460	469	20	773	680	600	500	40	5	104.39	17.5
TCH10056H10B00 (01)	560	569	10	873	780	750	600	15	6	104.52	19.4
TCH10056H20B00 (01)	560	569	20	873	780	750	600	15	6	116.69	19.4
TCH10066H10B00 (01)	660	669	10	973	880	750	700	65	6	116.72	21.4
TCH10066H20B00 (01)	660	669	20	973	880	750	700	65	6	128.89	21.4
TCH10076H10B00 (01)	760	769	10	1 073	980	900	800	40	7	141.19	23.4
TCH10076H20B00 (01)	760	769	20	1 073	980	900	800	40	7	153.37	23.4
TCH10086H20B00 (01)	860	869	20	1 173	1 080	1 050	900	15	8	153.37	25.3
TCH10096H20B00 (01)	960	969	20	1 273	1 180	1 050	1 000	65	8	165.61	27.3
TCH10106H20B00 (01)	1 060	1 069	20	1 373	1 280	1 200	1 100	40	9	177.86	29.2
TCH10116H20B00 (01)	1 160	1 169	20	1 473	1 380	1 350	1 200	15	10	190.10	31.2

C-2-6 Accessories

C-2-6. 1 Sensor Unit

Reference number TC - SRH - 1

Nominal size

Coding for model no.
 0: Proximity switch (3 b-contacts)
 1: Proximity switch (3 a-contacts)
 2: Proximity switch (1 a-contact, 2 b-contacts)
 3: Photo sensor (3 sensors)

◆ Proximity switch

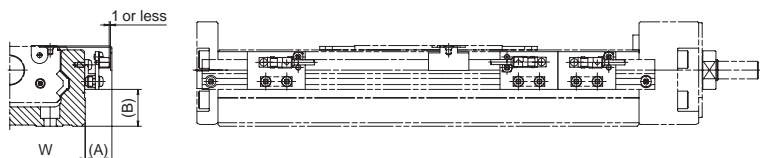

Model no.	Reference number			Dimensions		
				A (mm)	B (mm)	Body width W (mm)
TCH06	TC-SRH06-10	TC-SRH06-11	TC-SRH06-12	17	10	60
TCH09	TC-SRH09-10	TC-SRH09-11	TC-SRH09-12	16	21	86
TCH10	TC-SRH10-10	TC-SRH10-11	TC-SRH10-12	16	25	100

Quantity	Proximity switch (a-contact)	Proximity switch (b-contact)		
	—	3	1	E2S-W13 (OMRON Corp.)
	3	—	2	E2S-W14 (OMRON Corp.)

◆ Photo sensor

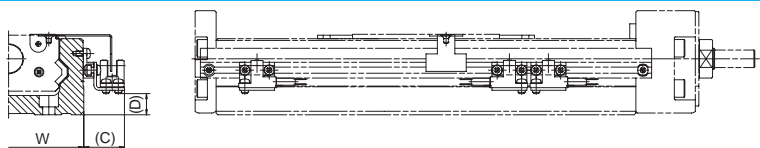

Model no.	Reference number	Dimensions			Note
		C (mm)	D (mm)	Body width W (mm)	
TCH06	TC-SRH06-13	24	2	60	EE-SX674 (OMRON Corp.) 3 sets (EE-1001 connector included)
TCH09	TC-SRH09-13	24	12	86	
TCH10	TC-SRH10-13	24	16	100	

(1) Sensor Rail

Reference number TC - SRL

Body rail length

Nominal no. 06→6
 09→9
 10→1

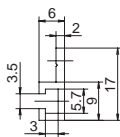
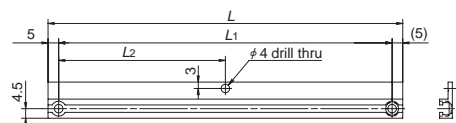

Model no.	Body rail length	Dimensions		
		L	L ₁	L ₂
TCH06	150	168	158	79
	200	218	208	104
	300	318	308	154
	400	418	408	204
	500	518	508	254
	600	618	608	304
TCH09	240	258	248	124
	340	358	348	174
	440	458	448	224
	540	558	548	274
	640	658	648	324
	740	758	748	374
TCH10	840	858	848	424
	940	958	948	474
	280	298	288	144
	380	398	388	194
	480	498	488	244
	580	598	588	294
	680	698	688	344
	780	798	788	394
	880	898	888	444
	980	998	988	494
	1 080	1 098	1 088	544
	1 180	1 198	1 188	594
	1 280	1 298	1 288	644
	1 380	1 398	1 388	694

C-2-6. 2 Cover Unit

◆ Cover Unit

TC-HV06XXXK00

TC-HV06XXXD00

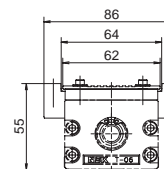
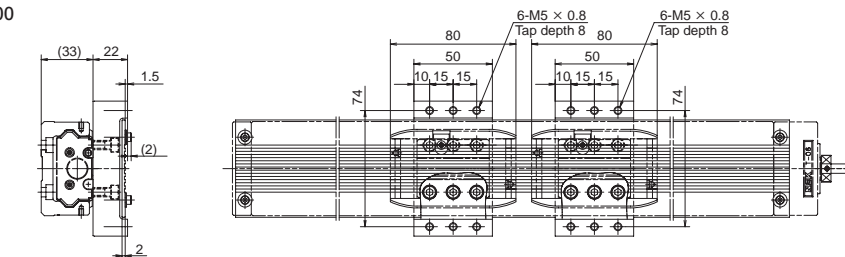

TC-HV06XXXA00

TC-HV06XXXB00

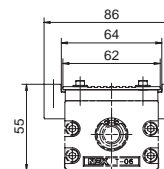
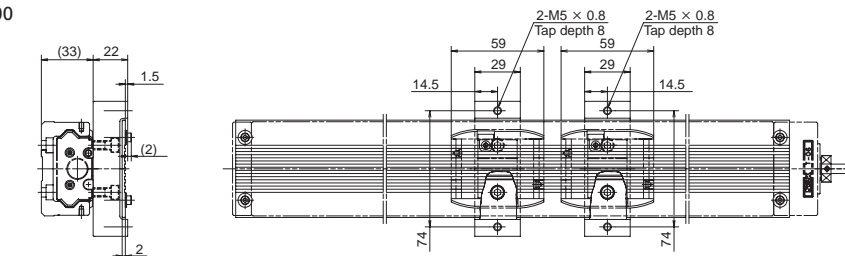

TCH06

Body rail length	Dimensions	Slider specifications			
		Standard		Short	
		Single	Double	Single	Double
150	L	TC-HV06005K00	—	TC-HV06007A00	—
200	220	TC-HV06010K00	—	TC-HV06012A00	—
300	320	TC-HV06020K00	TC-HV06013D00	TC-HV06022A00	TC-HV06017B00
400	420	TC-HV06030K00	TC-HV06023D00	TC-HV06032A00	TC-HV06027B00
500	520	TC-HV06040K00	TC-HV06033D00	TC-HV06042A00	TC-HV06037B00
600	620	TC-HV06050K00	TC-HV06043D00	TC-HV06052A00	TC-HV06047B00

TC-HV09XXXXK00
TC-HV09XXXD00

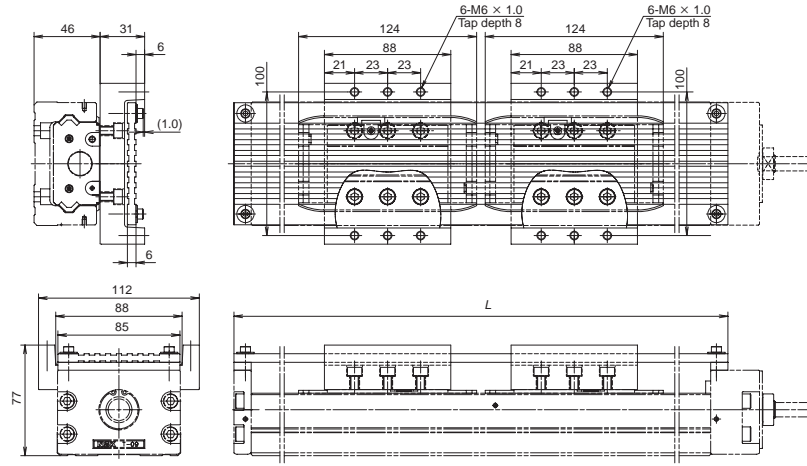

TC-HV09XXXXA00
TC-HV09XXXB00

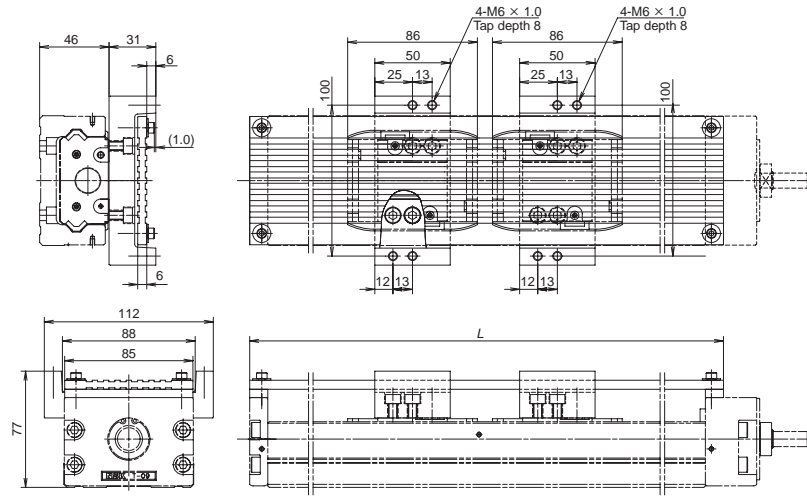

TC-HV10XXXXK00
TC-HV10XXXD00

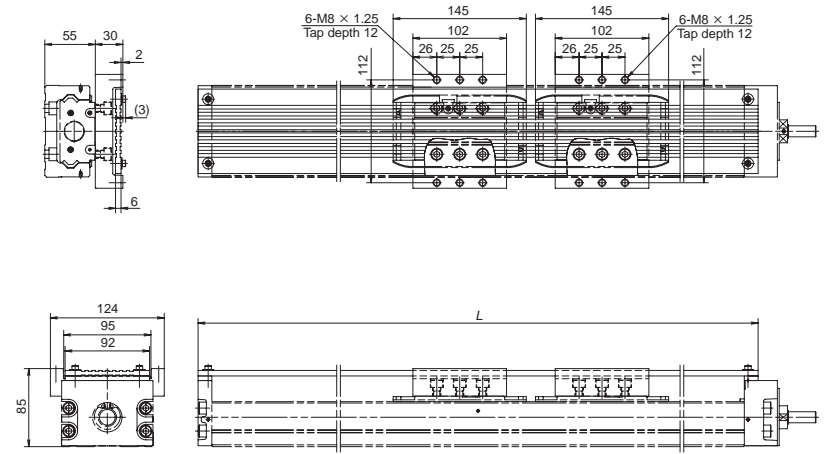

TC-HV10XXXXA00
TC-HV10XXXB00

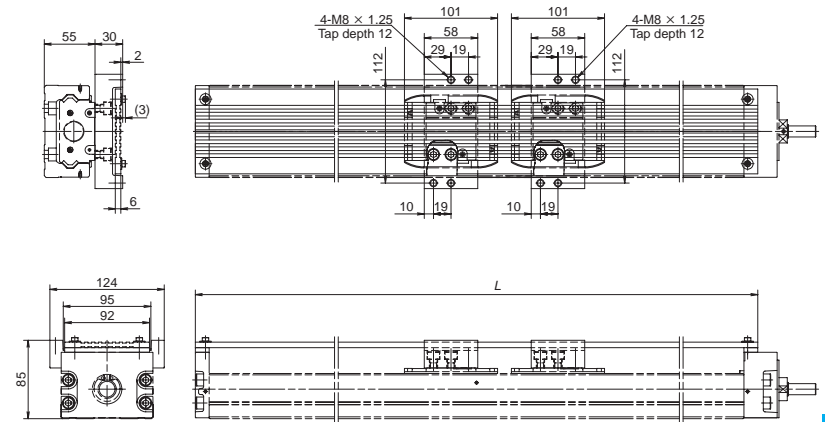

TCH09

Body rail length	Dimensions L	Slider specifications			
		Standard		Short	
		Single	Double	Single	Double
240	264	TC-HV09010K00	—	TC-HV09014A00	—
340	364	TC-HV09020K00	—	TC-HV09024A00	—
440	464	TC-HV09030K00	TC-HV09017D00	TC-HV09034A00	TC-HV09025B00
540	564	TC-HV09040K00	TC-HV09027D00	TC-HV09044A00	TC-HV09035B00
640	664	TC-HV09050K00	TC-HV09037D00	TC-HV09054A00	TC-HV09045B00
740	764	TC-HV09060K00	TC-HV09047D00	TC-HV09064A00	TC-HV09055B00
840	864	TC-HV09070K00	—	TC-HV09074A00	—
940	964	TC-HV09080K00	TC-HV09067D00	TC-HV09084A00	TC-HV09075B00

TCH10

Body rail length	Dimensions L	Slider specifications			
		Standard		Short	
		Single	Double	Single	Double
280	310	TC-HV10010K00	—	TC-HV10016A00	—
380	410	TC-HV10020K00	—	TC-HV10026A00	—
480	510	TC-HV10030K00	—	TC-HV10036A00	—
580	610	TC-HV10040K00	TC-HV10027D00	TC-HV10046A00	TC-HV10036B00
680	710	TC-HV10050K00	TC-HV10037D00	TC-HV10056A00	TC-HV10046B00
780	810	TC-HV10060K00	TC-HV10047D00	TC-HV10066A00	TC-HV10056B00
880	910	TC-HV10070K00	TC-HV10057D00	TC-HV10076A00	TC-HV10066B00
980	1 010	TC-HV10080K00	TC-HV10067D00	TC-HV10086A00	TC-HV10076B00
1 080	1 110	TC-HV10090K00	TC-HV10077D00	TC-HV10096A00	TC-HV10086B00
1 180	1 210	TC-HV10100K00	TC-HV10087D00	TC-HV10106A00	TC-HV10096B00
1 280	1 310	TC-HV10110K00	TC-HV10097D00	TC-HV10116A00	TC-HV10106B00
1 380	1 410	TC-HV10120K00	TC-HV10107D00	TC-HV10126A00	TC-HV10116B00

C-2-6. 3 Motor Bracket

◆ Motor bracket

Motor models are subject to change at the motor manufacturers. For details, please contact the manufacturer. For motors other than applicable motors shown below, please contact NSK.

■ Reference number

TC-BKH06-145-00

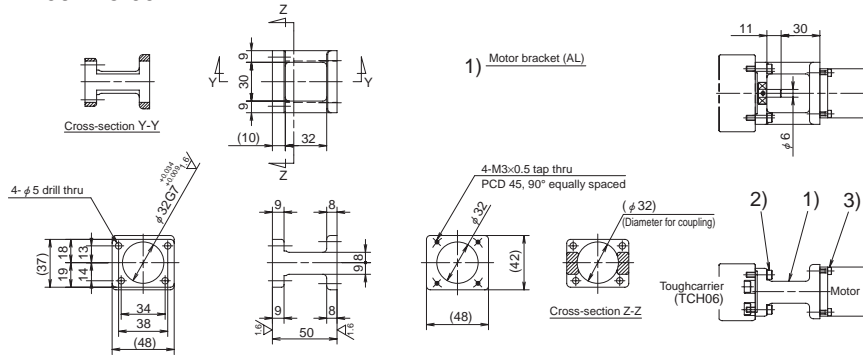

- 2) Hexagon socket head cap screw (M4, length 16)
- 3) Hexagon socket head cap screw (M3, length 12)

Notes: 1. Be sure to align the center lines when installing the motor.
2. Be careful of the assembly orientation of the bracket.
3. As the bracket is made by sand casting, the external dimensions are for reference only.

Applicable motors

Manufacturer	Motor model
Panasonic Co., Ltd.	MSMD5A(50W), MSMD10(100W)

■ Reference number

TC-BKH06-148-00

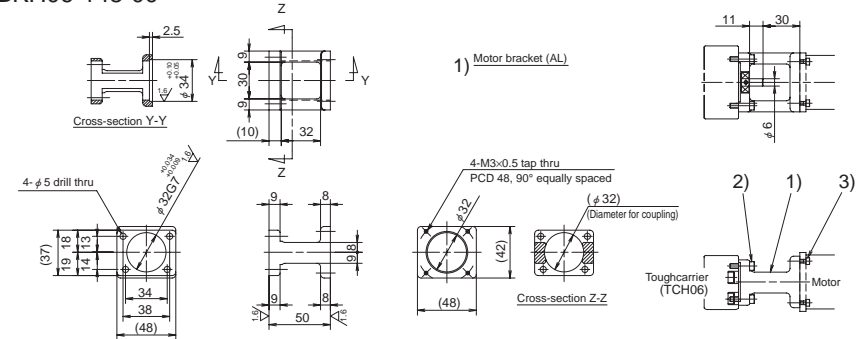

- 2) Hexagon socket head cap screw (M4, length 16)
- 3) Hexagon socket head cap screw (M3, length 12)

Notes: 1. Be sure to align the center lines when installing the motor.
2. Be careful of the assembly orientation of the bracket.
3. As the bracket is made by sand casting, the external dimensions are for reference only.

Applicable motors

Manufacturer	Motor model
Panasonic Co., Ltd.	MAMA01(100W)
SANYO DENKI Co., Ltd.	P50B04006(60W), P50B04010(100W)

■ Reference number

TC-BKH06-146-00

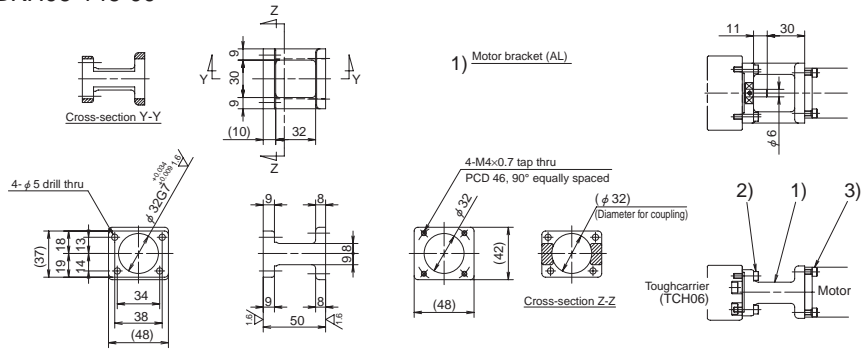

- 2) Hexagon socket head cap screw (M4, length 16)
- 3) Hexagon socket head cap screw (M4, length 14)

Notes: 1. Be sure to align the center lines when installing the motor.
2. Be careful of the assembly orientation of the bracket.
3. As the bracket is made by sand casting, the external dimensions are for reference only.

Applicable motors

Manufacturer	Motor model
YASKAWA Electric Corp.	SGMJV-A5A(50W), SGMJV-A5A(50W), SGMJV-01A(100W), SGMJV-01A(100W), SGMJV-C2A(150W), SGMJV-C2A(150W)
Mitsubishi Electric Corp.	HF-KP053(50W), HF-MP053(50W), HC-KF5053(50W), HCMF5053(50W), HF-KP13(100W), HF-MP13(100W), HCKFS13(100W), HC-MFS13(100W)
OMRON Corp.	R88M-W03(30W), R88M-W05(50W), R88M-W10(100W), P30B04003(30W), P30B04005(50W), P30B04010(100W)
SANYO DENKI Co., Ltd.	R2AA04005(50W), R2AA04010(100W)

■ Reference number

TC-BKH06-160-00

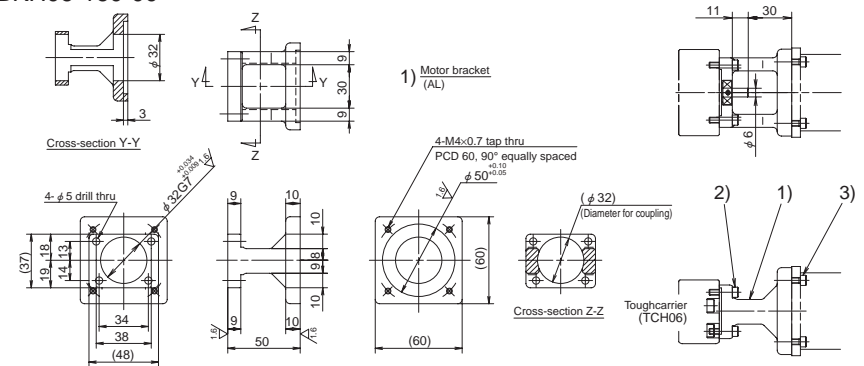

- 2) Hexagon socket head cap screw (M4, length 16)
- 3) Hexagon socket head cap screw (M4, length 14)

Notes: 1. Be sure to align the center lines when installing the motor.
2. Be careful of the assembly orientation of the bracket.
3. As the bracket is made by sand casting, the external dimensions are for reference only.

Applicable motors

Manufacturer	Motor model
SANYO DENKI Co., Ltd.	P50B05005(50W), P50B05010(100W), P50B05020(200W)

C-2-7 Motor Bracket Compatibility Table

Model No.	Reference number	Motor manufacturer	Stepping motor model no.	Wattage of AC servo motor											
				30W	50W	60W	100W	150W	200W	300W	400W	750W			
TCH06	TC-BKH06-145-00	Panasonic Co., Ltd.			MSMD5A		MSMD10								
	TC-BKH06-146-00	YASKAWA Electric Corp.			SGMJV-AS4 SGMAV-AS4		SGMJV-01A SGMAV-01A	SGMJV-C2A SGMAV-C2A							
		Mitsubishi Electric Corp.			HF-KP053 HF-MP053 HC-KFS053 HC-MFS053		HF-KP13 HF-MP13 HC-KFS13 HC-MFS13								
		OMRON Corp.		R88M-W03	R88M-V05		R88M-W10								
		SANYO DENKI Co., Ltd.		F30B04003	F30B04005 R2AA04005		F30B04010 R2AA04010								
	TC-BKH06-148-00	Panasonic Co., Ltd.					MAMA01								
	TC-BKH06-160-00	SANYO DENKI Co., Ltd.				P50B05005	P50B04010	P50B04010		P50B05020					
	TC-BKH06-250-00	SANYO DENKI Co., Ltd.		P6M603XXX P6M604XXX 103F78XX											
		ORIENTAL MOTOR Co., Ltd.		AS98 ASC98 UPK59X PK59X CSK59X CFK59X UFK59X											
	TCH09	TC-BKH09-145-00	Panasonic Co., Ltd.					MSMD01							
TC-BKH09-146-00		YASKAWA Electric Corp.					SGMJV-01A SGMAV-01A	SGMJV-C2A SGMAV-C2A							
		Mitsubishi Electric Corp.				HF-KP13 HF-MP13 HC-KFS13 HC-MFS13									
		SANYO DENKI Co., Ltd.				F30B04005	F30B04010 R2AA04010								
TC-BKH09-160-00		SANYO DENKI Co., Ltd.				P50B05005	P50B05010								
TC-BKH09-170-00		YASKAWA Electric Corp.						SGMJV-02A SGMAV-02A					SGMJV-04A SGMAV-04A		
		Mitsubishi Electric Corp.						HF-KP23 HF-MP23 HC-KFS23 HC-MFS23					HF-KP43 HF-MP43 HC-KFS43 HC-MFS43		
		OMRON Corp.						R88M-V20				R88M-V40			
		SANYO DENKI Co., Ltd.						F30B06020 R2AA06020				F30B06040 R2AA06040			
TC-BKH09-170-01		Panasonic Co., Ltd.										MSMD02 MAMA04		MSMD04 MAMA04	
TC-BKH09-190-00	SANYO DENKI Co., Ltd.								P50B07020	P50B07030	P50B07040				
TC-BKH09-250-00	SANYO DENKI Co., Ltd.		P6M603XXX P6M604XXX 103F78XX												
	ORIENTAL MOTOR Co., Ltd.		AS98 ASC98 UPK59X PK59X CSK59X CFK59X UFK59X												
TC-BKH09-270-00	ORIENTAL MOTOR Co., Ltd.		AS98 UPK59X PK59X CSK59X CFK59X UFK59X												
TCH10	TC-BKH10-170-00	YASKAWA Electric Corp.						SGMJV-02A SGMAV-02A				SGMJV-04A SGMAV-04A			
		Mitsubishi Electric Corp.					HF-KP23 HF-MP23 HC-KFS23 HC-MFS23					HF-KP43 HF-MP43 HC-KFS43 HC-MFS43			
		OMRON Corp.					R88M-V20					R88M-V40			
	TC-BKH10-170-01	SANYO DENKI Co., Ltd.						F30B06020 R2AA06020				F30B06040 R2AA06040			
		Panasonic Co., Ltd.										MSMD02 MAMA02		MSMD04 MAMA04	
	TC-BKH10-190-00	Panasonic Co., Ltd.												MSMD08 MAMA08	
	TC-BKH10-270-00	SANYO DENKI Co., Ltd.									P50B07020	P50B07030	P50B07040		
		SANYO DENKI Co., Ltd.													
		ORIENTAL MOTOR Co., Ltd.		103FB5XX											

Reference number TC-BKH10-190-00

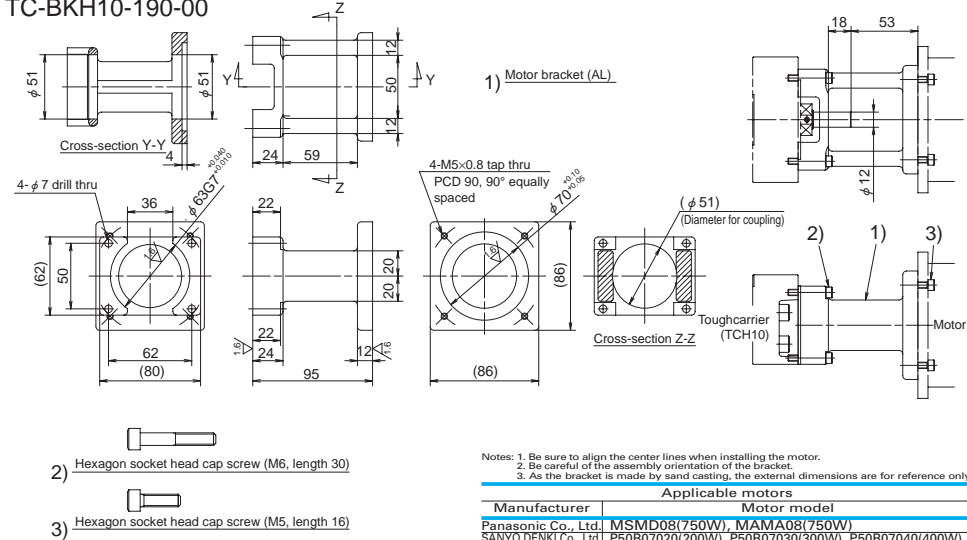

Reference number TC-BKH10-270-00

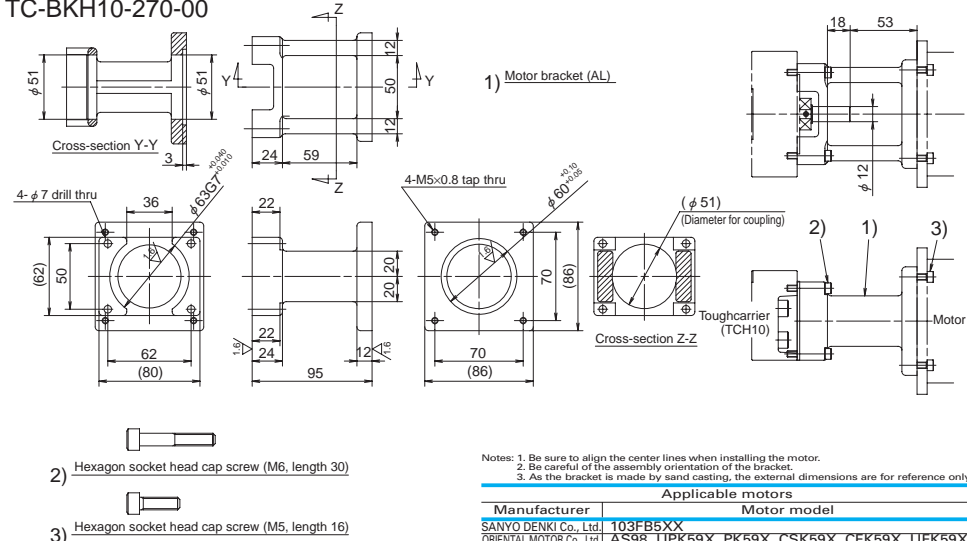

C-2-8 Sensor Rail and Top Cover Unit Combination Table

Model No.	Reference number	Rail length (L)	Sensor rail reference number	Cover unit reference number			
TCH06	TCH06005H05K00	150	TC-SRL6-0150	TC-HV06005K00			
	TCH06005H10K00						
	TCH06005H20K00						
	TCH06007H05A00						
	TCH06007H10A00	200	TC-SRL6-0200	TC-HV06007A00			
	TCH06010H05K00						
	TCH06010H10K00						
	TCH06010H20K00						
	TCH06012H05A00	300	TC-SRL6-0300	TC-HV06012A00			
	TCH06012H10A00						
	TCH06020H05K00						
	TCH06020H10K00						
	TCH06020H20K00						
	TCH06013H05D00						
	TCH06013H10D00						
	TCH06022H05A00						
	TCH06022H10A00						
	TCH06017H05B00						
	TCH06017H10B00						
	TCH06030H05K00				400	TC-SRL6-0400	TC-HV06030K00
	TCH06030H10K00						
	TCH06030H20K00						
	TCH06023H05D00						
	TCH06023H10D00						
	TCH06032H05A00						
	TCH06032H10A00						
	TCH06027H05B00						
	TCH06027H10B00						
	TCH06040H05K00	500	TC-SRL6-0500	TC-HV06040K00			
	TCH06040H10K00						
	TCH06040H20K00						
	TCH06033H05D00						
	TCH06033H10D00						
	TCH06042H05A00						
	TCH06042H10A00						
	TCH06037H05B00						
	TCH06037H10B00						
	TCH06050H05K00				600	TC-SRL6-0600	TC-HV06050K00
	TCH06050H10K00						
	TCH06050H20K00						
	TCH06043H10D00						
	TCH06043H20D00						
	TCH06052H05A00						
	TCH06052H10A00						
	TCH06047H10B00						
	TCH06047H10B00						

- Sensor rail reference numbers are determined according to the rail length. Select a sensor rail appropriate for your requirements.
- Shapes and numbers of spacer plates for cover unit are selected according to slider specifications.

Model No.	Reference number	Rail length (L)	Sensor rail reference number	Cover unit reference number			
TCH09	TCH09010H05K00	240	TC-SRL9-0240	TC-HV09010K00			
	TCH09010H10K00						
	TCH09010H20K00						
	TCH09014H05A00						
	TCH09014H10A00	340	TC-SRL9-0340	TC-HV09014A00			
	TCH09014H20A00						
	TCH09020H05K00						
	TCH09020H10K00						
	TCH09020H20K00	440	TC-SRL9-0440	TC-HV09020K00			
	TCH09024H05A00						
	TCH09024H10A00						
	TCH09024H20A00						
	TCH09030H05K00						
	TCH09030H10K00						
	TCH09030H20K00						
	TCH09017H05D00						
	TCH09017H10D00						
	TCH09034H05A00						
	TCH09034H10A00						
	TCH09034H20A00						
	TCH09025H05B00	540	TC-SRL9-0540	TC-HV09025B00			
	TCH09025H10B00						
	TCH09040H05K00						
	TCH09040H10K00						
	TCH09040H20K00						
	TCH09027H05D00						
	TCH09027H10D00						
	TCH09044H05A00						
	TCH09044H10A00						
	TCH09044H20A00						
	TCH09035H05B00						
	TCH09035H10B00						
	TCH09050H05K00	640	TC-SRL9-0640	TC-HV09050K00			
	TCH09050H10K00						
	TCH09050H20K00						
	TCH09037H05D00						
	TCH09037H10D00						
	TCH09054H05A00						
	TCH09054H10A00						
	TCH09054H20A00						
	TCH09045H05B00						
	TCH09045H10B00						
	TCH09060H05K00				740	TC-SRL9-0740	TC-HV09060K00
	TCH09060H10K00						
	TCH09060H20K00						
	TCH09047H10D00						
	TCH09047H20D00						
	TCH09064H05A00						
TCH09064H10A00							
TCH09064H20A00							
TCH09055H10B00							
TCH09055H20B00							
TCH09070H05K00	840	TC-SRL9-0840	TC-HV09070K00				
TCH09070H10K00							
TCH09070H20K00							
TCH09074H05A00							
TCH09074H10A00							
TCH09074H20A00							
TCH09080H05K00							
TCH09080H10K00							
TCH09080H20K00							
TCH09067H10D00							
TCH09067H20D00							
TCH09084H05A00				940	TC-SRL9-0940	TC-HV09084A00	
TCH09084H10A00							
TCH09084H20A00							
TCH09075H10B00							
TCH09075H20B00							

- Sensor rail reference numbers are determined according to the rail length. Select a sensor rail appropriate for your requirements.
- Shapes and numbers of spacer plates for cover unit are selected according to slider specifications.

Model No.	Reference number	Rail length (L)	Sensor rail reference number	Cover unit reference number				
TCH10	TCH10010H10K00	280	TC-SRL1-0280	TC-HV10010K00				
	TCH10010H20K00			TC-HV10016A00				
	TCH10016H10A00	380	TC-SRL1-0380	TC-HV10020K00				
	TCH10016H20A00			TC-HV10026A00				
	TCH10020H10K00			480	TC-SRL1-0480	TC-HV10030K00		
	TCH10020H20K00					TC-HV10036A00		
	TCH10026H10A00	580	TC-SRL1-0580			TC-HV10040K00		
	TCH10026H20A00					TC-HV10027D00		
	TCH10030H10K00					TC-HV10046A00		
	TCH10030H20K00					TC-HV10036B00		
	TCH10036H10A00			680	TC-SRL1-0680	TC-HV10050K00		
	TCH10036H20B00					TC-HV10037D00		
	TCH10040H10K00					TC-HV10056A00		
	TCH10040H20K00					TC-HV10046B00		
	TCH10027H10D00			780	TC-SRL1-0780	TC-HV10060K00		
	TCH10027H20D00					TC-HV10047D00		
	TCH10046H10A00					TC-HV10066A00		
	TCH10046H20A00					TC-HV10056B00		
	TCH10036H10B00					880	TC-SRL1-0880	TC-HV10070K00
	TCH10036H20B00							TC-HV10057D00
	TCH10050H10K00	TC-HV10076A00						
	TCH10050H20K00	TC-HV10066B00						
	TCH10037H10D00	980	TC-SRL1-0980					TC-HV10080K00
	TCH10037H20D00							TC-HV10067D00
	TCH10056H10A00			TC-HV10086A00				
	TCH10056H20A00			TC-HV10076B00				
	TCH10070H10K00			1 080	TC-SRL1-1080			TC-HV10090K00
	TCH10070H20K00							TC-HV10077D00
	TCH10066H10B00					TC-HV10096A00		
	TCH10066H20B00					TC-HV10086B00		
	TCH10077H10D00					1 180	TC-SRL1-1180	TC-HV10100K00
	TCH10077H20D00							TC-HV10087D00
	TCH10096H10A00	TC-HV10106A00						
	TCH10096H20A00	TC-HV10096B00						
	TCH10086H20B00	1 280	TC-SRL1-1280					TC-HV10110K00
	TCH10100H10K00							TC-HV10097D00
	TCH10100H20K00			TC-HV10116A00				
	TCH10087H20D00			TC-HV10106B00				
	TCH10106H10A00			1 380	TC-SRL1-1380			TC-HV10120K00
	TCH10106H20A00							TC-HV10107D00
	TCH10096H20B00					TC-HV10126A00		
	TCH10110H10K00					TC-HV10116B00		
	TCH10110H20K00					1 380	TC-SRL1-1380	TC-HV10120K00
	TCH10097H20D00							TC-HV10107D00
	TCH10116H10A00	TC-HV10126A00						
	TCH10116H20A00	TC-HV10116B00						
	TCH10106H20B00	TC-HV10120K00						
	TCH10120H10K00	TC-HV10107D00						
	TCH10120H20K00	TC-HV10126A00						
	TCH10107H20D00	TC-HV10116B00						
	TCH10126H10A00							
	TCH10126H20A00							
	TCH10116H20B00							

• Sensor rail reference numbers are determined according to the rail length. Select a sensor rail appropriate for your requirements.
 • Shapes and numbers of spacer plates for cover unit are selected according to slider specifications.

C-2-9 Toughcarrier High-Thrust Series (Special product)

◆ Specifications

The life of the feeding system is improved by use of higher load capacity ball screw part and support bearings for standard Toughcarrier.

		TCH06		TCH09		TCH10	
Ball screw	Shaft diameter (mm)	12		20		25	
	Lead (mm)	10	20	10	20	20	25
	Basic dynamic load rating Ca (N)	3 760	2 970	11 500	8 790	9 760	9 760
	Basic static load rating Coa (N)	6 310	4 240	25 700	18 500	23 600	23 600
Linear guide	Basic dynamic load rating C (N)	20 900		44 900		62 400	
	Basic static load rating Co (N)	45 000		96 900		132 000	
Support bearings	Basic dynamic load rating (N)	5 900		18 800		21 900	
	Load limit (N)	3 500		11 500		26 600	

- 1) Only compatible with standard slider.
- 2) Applicable strokes are as follows.
 TCH06: Stroke 500 mm
 TCH09: Stroke 800 mm
 TCH10: Stroke 1 200 mm
- 3) High and precision grades are available for accuracy

◆ Features

- 1) Mounting dimensions are the same as Monocarrier MCH Series and standard Toughcarrier. (Interchangeable)
- 2) Permissible rotational speed is faster than standard Toughcarrier due to different ball recirculation system.

Toughcarrier

C-3 Technical Materials

1. Sensor Specification	C135
1.1 Proximity Switch	C135
1.2 Photo Sensor	C136
2. Characteristics and Evaluation Method	C137
2.1 Positioning Accuracy	C137
2.2 Repeatability	C137
2.3 Running Parallelism	C137
3. Special Specifications	C138
4. Maintenance	C139
4.1 Maintenance Method	C139
4.2 NSK K1™ Lubricant Unit	C139
5. NSK Clean Grease LG2 Specification	C140

C-3 Technical Materials

C-3-1 Sensor Specification

C-3-1. 1 Proximity Switch

Use of OMRON E2S-W13 and E2S-W14

Item	E2S-W13 type	E2S-W14 type
Setting surface	Front face	
Sensing distance	1.6 mm ±15%	
Setting distance	0 to 1.2 mm	
Differential travel	10% max. of sensing distance	
Detectable object type	Ferrous metal	
Standard sensing object	Iron, 12 × 12 × 1 mm	
Response frequency	1 kHz min.	
Power supply voltage (operating voltage range)	12 to 24 VDC; ripple (p-p), 10% max (10 to 30 VDC)	
Current consumption	13 mA max. at 24 VDC with no load	
Control output (Switching Capacity)	NPN open collector output, 50 mA max. (30 VDC max.)	
Control output (Residual voltage)	1.0 V max. with a load current of 50 mA and a cable length of 1 m	
Indicator	Operation indicator (orange)	
Operating status (with sensing object approaching)	NO (Normally open contact)	NC (Normally close contact)
Wire lead length	1 000 mm	

Notes: 1) Do not make a wrong connection.
2) Please contact NSK for PNP output type.

Movement mode	Output type	Type	Time chart	Output circuit
NO	NPN	E2S-W13 type	Target object Yes Output transistor (load) ON Output transistor (orange) OFF	
			Target object No Output transistor (load) OFF Output transistor (orange) ON	
NC	NPN	E2S-W14 type	Target object Yes Output transistor (load) ON Output transistor (orange) OFF	
			Target object No Output transistor (load) OFF Output transistor (orange) ON	

E2S-W13 (Normally open contact)
E2S-W14 (Normally close contact)
The external appearances are the same.

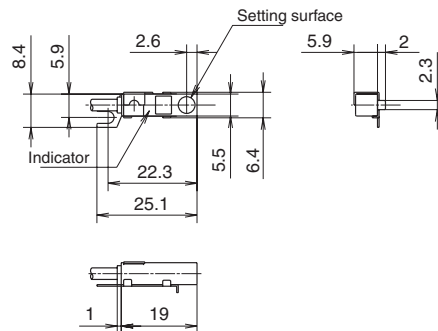

C-3-1. 2 Photo Sensor

Use of OMRON EE-SX674

Item	EE-SX674 type
Slot width	5 mm
Standard reference object	Opaque, 2 × 0.8 mm
Differential distance	0.025 mm
Light source	GaAs infrared LED with peak wavelength of 940 nm
Indicator (without detecting object)	ON GaP red LED (peak emission wavelength, 690 nm)
Supply voltage	5 to 24 VDC ±10%; ripple (p-p), 10% max.
Current consumption	35 mA max.
Control output	NPN open collector output models, 5 to 24 VDC, 100 mA load current
Response frequency	1 kHz max. (3 kHz typ.)
Ambient illumination	Fluorescent light, 1 000 lx max.
Ambient temperature	-25°C to 55°C (-13°F to 131°F) (for operating); -30°C to 80°C (-22°F to 176°F) (for storing)
Ambient humidity	5 to 85% RH (for operating); 5 to 95% RH (for storing)
Connecting method	EE-1001/1006 Connectors, soldering terminals

Notes: 1) Do not make a wrong connection.
2) Please contact NSK for PNP output type.

Type	Movement mode	Time chart	Connection terminal	Output circuit
EE-SX674 type	Light-ON	Incident Interrupted Indicator (red) ON Output transistor ON Load 1 (relay) Operates Load 2 L Releases	When terminals L and ⊕ are short circuited	
	Dark-ON	Incident Interrupted Indicator (red) ON Output transistor ON Load 1 (relay) Operates Load 2 L Releases	When terminals L and ⊕ are open circuited	

EE-SX674 (Sensor)
EE-1001 (Connector)

A connector is mounted to the sensor in the right figure.

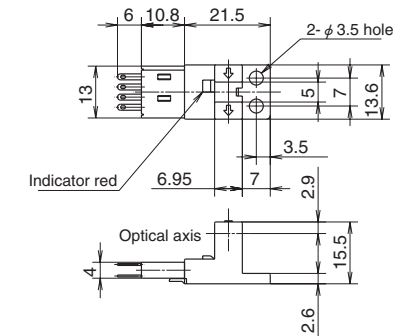

C-3-2 Characteristics and Evaluation Method

C-3-2. 1 Positioning Accuracy

Perform successive positioning from the reference position in a specific direction. Measure the difference between the actual and desired travel distances for each point from the reference position. Repeat this measurement seven times to determine the average value. Measure such average value over the entire travel distance at the intervals specified for each model and take the maximum difference of the average values determined at respective positions as the measured value.

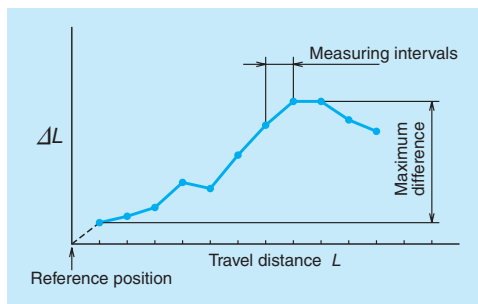

Fig. 1

C-3-2. 2 Repeatability

Repeat positioning at any point seven times from the same direction to measure the stopping position and determine one half of the maximum difference of readings. Repeat this measurement over the entire travel distance at the intervals specified for each model. Take the maximum difference of the determined values as the measured value. Express one half of the maximum difference with a plus-or-minus (\pm) sign.

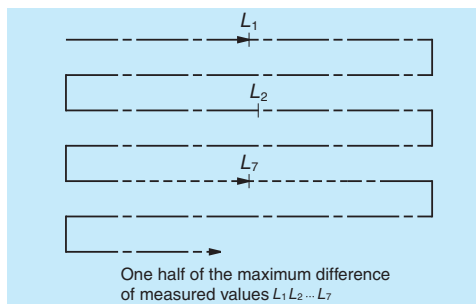

Fig. 2

C-3-2. 3 Running Parallelism (Vertical direction)

We specify the parallelism of slider to the datum bottom surface of rail. An indicator is moved in the axial slider making its stylus slightly touching on the rail bottom surface. The slider is moved in the axial direction for the checking. We define the total indicator reading as the running parallelism. During the checking, the rail is not fixed to the table base. Please be aware that, in general application, the rail is fixed to the machine base, and thus the wobbly rolling error will be added to the running parallelism.

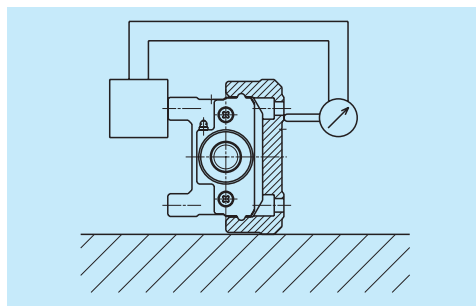

Fig. 3 Setting of indicator

C-3-3 Special Specifications

Please consult NSK if your requirement is not in the standard products.

(1) Surface Treatment

- Fluoride low temperature chrome plating

Note: Ball screw parts (including low temperature chrome plating.)

(2) Special Machining (Processing)

- i) Shaft end processing
 - Key way processing
 - One flat or two flats processing
- ii) Pin hole processing
 - Slider
 - Rail

Note: Due to interference with the internal construction, the position of pin hole is limited. Please consult with NSK about the pin position.

(3) Motor Bracket and Intermediate Plate for Motor Mounting

- We provide motor mounting brackets and intermediate plates that are not listed in the catalog.
- We assemble motor upon request if the motor is provided in advance.

Note: Motion check of the motor is unavailable.

(4) Reversed Motor Mount

The reversed motor mount is available. Please consult NSK.

Notes: 1) We do not check motor running condition.

2) Please refer to the bottom of page C87 to C89 for the configuration of reversed motor mounting of the MCH series.

(5) Right and Left Turn Thread

Right and left turn ball screw is available. Please consult with NSK for available leads.

(6) Ball-Screw-Less Specification (Only Linear Guide Part)

A ball-screw-less rail part with the same cross section of standard Monocarriers is available for a driven linear guide. It will lessen a height adjustment work compared with a construction with two standard Monocarriers. Note: Height grinding adjustment of the two axes assembly is not available.

C-3-4 Maintenance

C-3-4.1 Maintenance Method

1. For standard Monocarrier, we pack grease in the slider, linear guides and ball screw.
2. Monocarriers are equipped with NSK K1 Lubrication Unit as a standard feature, therefore, you may use it for 5 years or 10 000 km depending on your application, whichever comes first, without maintenance. However, replenishment of preceded grease may extend its life substantially.
3. The NSK K1 Lubrication Unit is ideal in environments where oily dust exists. However, the life may be shorter than described in Clause 2 above. In such a case, it requires increasing the frequency of replenishment.

4. A Nozzle for the NSK grease pump for MCH Monocarriers is available as an option.
NSK reference number: NSK HGP NZ8

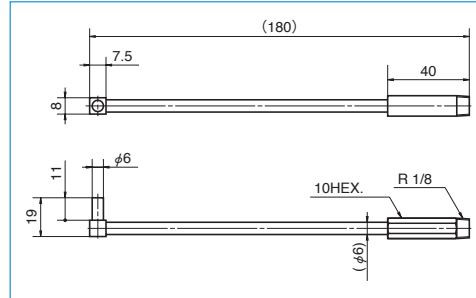

Fig. 4 NSK HGP NZ8

Precautions for handling

1. Please consult with NSK when the motor is coupled to the ball screw using a pulley because there is a restriction on allowable load to the end of ball screw shaft.
2. To extend high performance of NSK K1 lubrication unit, please observe the following.

- | | |
|----------------------|---|
| 1. Temperature range | Ambient temperature: 50°C
Max. instantaneous temperature: 80°C |
| 2. Use of chemicals | Never leave a Monocarrier in close proximity of grease removing organic solvents such as hexane or thinner. Never immerse it in an antirust solvent that contains kerosene. |

Note: Other oils, such as water-based and oil based cutting oil, and grease do not cause any problems.

C-3-4. 2 NSK K1™ Lubricant Unit

NSK K1 lubrication unit exhibits outstanding features, confirmed by abundant experimental data, along with proven performance of linear guides and ball screws that are equipped with NSK K1.

(1) High-Speed Durability Test of Linear Guides without Lubricant

Results of high-speed durability testing of a linear guide without lubricant are shown in Fig. 5 While the linear guide cannot be operated without lubricant for even short periods without damage, the installation of the NSK K1 permits the linear guide to run over 25 000 km without any problem.

Conditions	Test piece: LH30AN (Preload Z1)
	Speed: 3.3 m/s
	Stroke: 1 800 mm
No lubricant	All grease removed
NSK K1	All grease removed + NSK K1

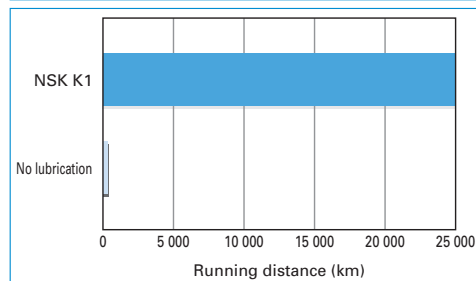

Fig. 5 Results of high-speed durability test of linear guides without lubricant

(2) High-Speed Durability Test of Ball Screws without Lubricant

Results of high-speed durability testing of ball screw without lubrication are shown in Fig. 6 While the ball screw cannot be operated without a lubricant at 8.5 km without damage, the installation of the NSK K1 permits the ball screw to run over 21 000 km without any problem.

Conditions	Test piece: BS2020 (Ball screw)
	Shaft diameter: 20 mm
	Lead: 20 mm
	Load: none
	Speed: 1.3 m/s (4 000 min ⁻¹)
	Stroke: 600 mm
No lubricant	All grease removed
NSK K1	All grease removed + NSK K1

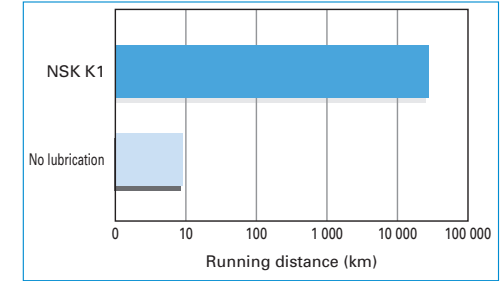

Fig. 6 Results of high-speed durability test of ball screws without lubricant

● **NSK K1 Lubrication Units for food processing and medical devices are available.**

For safety equipment of food processing and medical care, NSK provides the Monocarrier equipped with special NSK K1 Lubrication Unit that is made of materials approved by the FDA. Dimensions are the same as the standard NSK K1 Lubrication Unit, and special handling care is not required.

C-3-5 NSK Clean Grease LG2 Specification

● Features

This grease was developed by NSK to be exclusively used for linear guides and ball screws in clean rooms. Compared to the fluoride grease which are commonly used in clean rooms, LG2 has several advantages such as: higher in lubrication function, longer lubrication life, more stable torque (resistant to wear), and higher rust prevention. In dust generation, LG2 is more than equal to fluoride grease in keeping dust volume low. Since the base oil is not a special oil but a mineral oil, LG2 can be handled in the same manner as general grease.

● Applications

LG2 is lubrication grease for rolling contact machine components such as linear guides and ball screws for processing equipment for semiconductors and LCD which require highly clean environment at normal pressure in normal temperatures. It cannot be used in a vacuum environment.

● Nature

Thickener	Lithium soap base
Base oil	Mineral oil + Synthetic hydrocarbon oil
Consistency	199
Dropping point	201°C
Volume of evaporation	1.40% (99°C, 22 hr)
Copper plate corrosion test	Satisfactory (Method B, 100°C, 24 hr)
Oil separation	0.8% (100°C, 24 hr)
Base oil kinematic Viscosity	32 mm ² /s (40°C)

Other

Other

- 1. Special Environments D1
 - 1.1 Specifications for Special Environments D1
 - 1.2 Lubrication and Materials D3
 - 1.3 Rust Prevention and Surface Treatment D5
 - 1.4 Measures Against Special Environments D7
 - 1.5 Table to Cope with Special Environments D11
 - 1.6 Precautions for Handling..... D12
- 2. Lubrication D13
 - 2.1 Grease Lubrication..... D13
 - 2.2 Oil Lubrication D24
- 3. RoHS Compliant D24

1 Special Environments

1.1 Specifications for Special Environments

1. Linear guide

Table 1.1 Linear guide specifications

Environment	Condition	NSK linear guide specifications				Technical Explanation Page No.
		Rail, slide	Steel balls/rollers	Ball recirculation component	Lubrication/surface treatment	
Clean	Atmosphere, normal temperature	Standard material	Standard material	Standard material	LG2, LGU Grease	D8
					NSK K1 lubrication unit	D10
		Martensitic stainless steel	Martensitic stainless steel	Austenitic stainless steel	LG2, LGU Grease	D8
					NSK K1 lubrication unit	D10
Atmosphere-Vacuum, normal temperature			Fluoride low temperature chrome plating	D5		
Atmosphere-Vacuum up to 200°C			Fluoride grease			
Vacuum	Atmosphere-Vacuum, normal temperature	Martensitic stainless steel	Martensitic stainless steel	Austenitic stainless steel	Fluoride grease	
	Atmosphere-Vacuum up to 200°C					
	Atmosphere-Vacuum up to 300°C				Molybdenum disulfide	
	High vacuum up to 500°C				Special silver film	D7
Corrosion resistance	Vapor, steam	Martensitic stainless steel	Martensitic stainless steel	Austenitic stainless steel		D5
	Acid, alkali	Standard material	Standard material	Standard material	Fluoride low temperature chrome plating	D5
					D5	
	Acid, alkali, clean	Martensitic stainless steel	Martensitic stainless steel	Austenitic stainless steel	Fluoride low temperature chrome plating	D5
					LG2, LGU Grease	D8
					Fluoride low temperature chrome plating	D5
					Fluoride grease	
	Organic solvent				Fluoride grease	
High temperature	Atmosphere up to 150°C	Standard material	Standard material	Austenitic stainless steel	ET-100K Grease	
	Atmosphere up to 200°C				Fluoride grease	
	Atmosphere up to 200°C, Corrosion resistant				Fluoride grease	
Low temperature	-273°C and higher	Martensitic stainless steel	Martensitic stainless steel	Austenitic stainless steel	Solid lubricant	
Radiation resistance	Atmosphere	Standard material	Standard material	Standard material	Radiation resistant grease	
		Martensitic stainless steel	Martensitic stainless steel	Austenitic stainless steel		
Foreign matters	Fine particles, wooden chips	Standard material	Standard material	Standard material	NSK K1 lubrication unit	D10
			Martensitic stainless steel	Austenitic stainless steel		D10
	Water, under water	Martensitic stainless steel	Standard material	Standard material		D10
			Martensitic stainless steel	Austenitic stainless steel		D10

2. Ball screw

Table 1.2 Ball screw specifications

Environment	Condition	NSK Ball screw specification				Technical Explanation Page No.	
		Screw shaft, ball nut	Steel balls	Ball Recirculation component	Lubrication/surface treatment		
Clean	Atmosphere, normal temperature	Standard material	Standard material	Standard material	LG2, LGU Grease	D8	
					NSK K1 lubrication unit	D10	
		Martensitic stainless steel	Martensitic stainless steel	Austenitic stainless steel	LG2, LGU Grease	D8	
					NSK K1 lubrication unit	D10	
Atmosphere-Vacuum, normal temperature			Fluoride low temperature chrome plating	D5			
Atmosphere-Vacuum up to 200°C			Fluoride grease				
Vacuum	Atmosphere-Vacuum, normal temperature	Martensitic stainless steel	Martensitic stainless steel	Austenitic stainless steel	Ceramic	Fluoride grease	
	Atmosphere-Vacuum up to 200°C						
	Atmosphere-Vacuum up to 300°C						
	High vacuum up to 500°C						
Corrosion resistance	Acid, alkali, clean	Standard material	Standard material	Austenitic stainless steel	Fluoride low temperature chrome plating	D5	
		Martensitic stainless steel	Martensitic stainless steel			D5	
	Strong acid, strong alkali, clean, nonmagnetic	Precipitation hardening stainless steel	Precipitation hardening stainless steel	Ceramic	Ceramic	Fluoride grease	
		Ceramic	Ceramic				
Nonmagnetic	Atmosphere-Vacuum, clean	Special austenitic stainless steel	Ceramic	Ceramic	Austenitic stainless steel	Fluoride grease	
	Atmosphere-Vacuum, up to 200°C, clean	Ceramic			Fluoroplastic		
High temperature	Atmosphere up to 200°C	Standard material	Standard material	Austenitic stainless steel	Fluoride low temperature chrome plating	Fluoride grease	
	Atmosphere up to 200°C	Martensitic stainless steel	Martensitic stainless steel			D5	
	Atmosphere up to 500°C, corrosion resistance	Ceramic	Ceramic			Fluoride grease	
Low temperature	-273°C and higher	Martensitic stainless steel	Martensitic stainless steel	Austenitic stainless steel	Solid lubricant		
Radiation resistance	Atmosphere	Standard material	Standard material	Standard material	Radiation resistant grease		
		Martensitic stainless steel	Martensitic stainless steel	Austenitic stainless steel			
Foreign matters	Fine particles, wooden chips	Standard material	Standard material	Standard material	NSK K1 lubrication unit	D10	
			Martensitic stainless steel	Martensitic stainless steel		D10	
	Water, under water	Martensitic stainless steel	Martensitic stainless steel	Austenitic stainless steel		D10	

1.2 Lubrication and Materials

1. Lubrication

Grease can be used for high rotation and magnetic field. However, grease evaporates or solidifies in special environment such as vacuum, high temperature, and low temperature. Solid lubricant is

used when it is difficult to use grease. Functions of solid lubricant differ greatly by condition where it is used. It is important to select the most suitable solid lubrication for the environment.

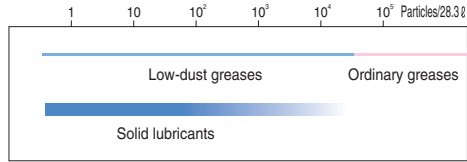

Fig. 2.1 Lubrication in clean environment

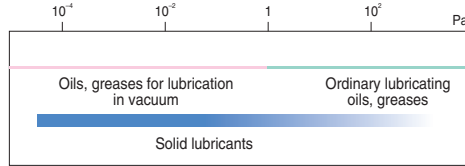

Fig. 2.2 Lubrication in vacuum

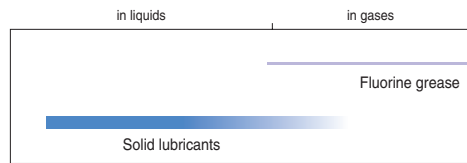

Fig. 2.3 Lubrication in corrosive environment

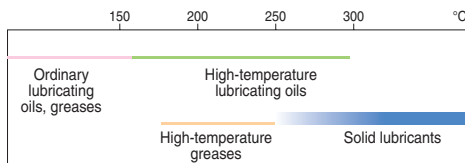

Fig. 2.4 Lubrication in high temperature

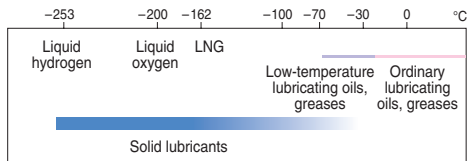

Fig. 2.5 Lubrication in low temperature

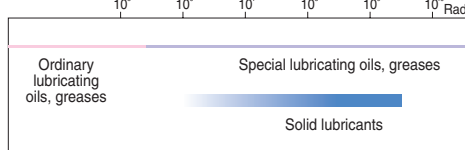

Fig. 2.6 Lubrication in radioactive environment

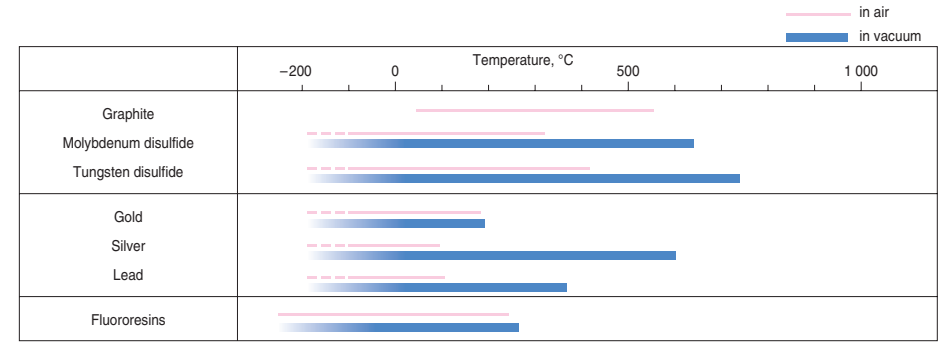

Fig. 2.7 Temperature range for using solid lubricants

2. Materials

Iron type metals are used in vacuum, high temperature, and high speed environments as the basic material. We generally use nonmagnetic stainless steel for nonmagnetic materials.

Table 2.1 Characteristics of metal materials

Application	Type of steel	Linear expansivity ×10 ⁻⁶ /°C	Young's modulus GPa	Hardness* HB
For clean environment, vacuum environment, corrosion resistance, low temperature, high temperature, radioactive resistance	Martensitic stainless steel SUS440C	10.1	200	580
	Austenitic stainless steel SUS304	16.3	193	150
	Precipitation hardening stainless steel SUS630	10.8	200	277 – 363
Nonmagnetic	Nonmagnetic stainless steel	17.0	195	420

*) Hardness of steel is usually indicated by Rockwell C Scale. For comparison, these figures are expressed by Brinell number.

1.3 Rust Prevention and Surface Treatment

1. Fluoride low temperature chrome plating

The use environment of NSK linear guides, ball screws and monocarriers is expanding from general industrial machines, semiconductor and liquid crystal manufacturing systems to aerospace equipment.

Among all measures to cope with environment, rust prevention is the most challenging. Such environment includes:

- Moisture for washing machines and other equipment
- Chemicals used in the wet processing of semiconductor and liquid crystal display manufacturing equipment.

NSK has developed electrolytic rust prevention black film treatment (black chrome plating) which is added by fluoro resin impregnating treatment. (Hereinafter referred as "Fluoride low temperature chrome plating".) This surface treatment methods has proved its superiority as the rust prevention of linear guides and ball screws which are used in the above equipment.

● Humidity chamber test

Table 3.1 Results of the humidity test

Test sample		Fluoride low temperature chrome plating (recommended)	Hard chrome plating (reference)	Electroless nickel plating (reference)	Equivalent to SUS440C material	Standard steel
Rusting	Top	(Ground) B	(Ground) B	(Ground) A	(Ground) C	(Ground) D
	Side	(Ground) A	(Ground) A	(Ground) A	(Ground) C	(Ground) E
	Bottom	(Ground) A	(Ground) A	(Ground) A	(Ground) C	(Ground) E
	End	(Machined) A	(Machined) C	(Machined) A	(Machined) C	(Machined) E
	Chamfer/grinding recess	(Drawn) A	(Drawn) D	(Drawn) A	(Drawn) C	(Drawn) E
Corrosion-resistant property	<Test conditions> ● Testing chamber: High temperature, highly moist chamber (made by DABAI ESPEC) ● Temperature: 70°C ● Relative humidity: 95% ● Testing time: 96 h Time to "ramp-up" and "ramp-down" condition of the temperature and the humidity conditions Ramp-up: 5 h Ramp-down: 2 h					
	Film thickness	5 μm	0.5 - 7 μm	10 μm	—	—

Rusting A: No rust B: Not rusted, but slightly discolored
C: Spotty rust D: slightly rusted E: Completely rusted

● What is "Fluoride low temperature chrome plating?"

This is a type of black chrome plating which forms a black film (1 to 2 μm in thickness) on the metal surface. Fluoroplastic coating is added to the film to increase corrosion resistance.

- Accuracy control is easily manageable due to low temperature treatment and to the absence of hydrogen embrittlement.
- Product accuracy is less affected due to the thin film which has high corrosion resistance.
- This method is superior to other surface treatments in durability on the rolling surface.
- Inexpensive compared with products with other surface treatment and stainless steel products.

Do not use organic solvent because it adversely affects antirust property of the plating.

● Chemical corrosion resistance test

Table 3.2 Results of the corrosion resistance test

Test conditions	Rail base material: Equivalent to SUS440C Chemical density: 1 mol/ℓ		
Fluoride low temperature chrome plating	Immersed in solution for 24 hrs Nitric acid	Hard chrome plating	None surface treatment
	Immersed in solution for 24 hrs Fluoride		
	Exposed to vapor for 72 hrs Hydrochloric acid type washing solution		
	HC ℓ : H ₂ O ₂ : H ₂ O = 1 : 1 : 8		
○	Hydrochloric acid (immersed)	○	▲
○	Sulfuric acid (immersed)	○	X
○	Ammonia or sodium hydroxide	○	△

○: Normal △: Partial surface damage ▲: Overall surface damage X: Corroded

● Surface treatment durability test

Peeling resistance of surface treatment

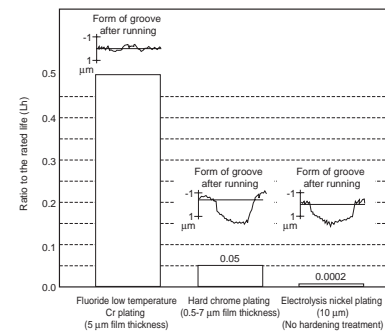

Fig. 3.1 Results of durability test

● Total evaluation

Table 3.3 Evaluation

	Available length	Rust prevention ability	Quality stability	Durability	Cost
Fluoride low temperature chrome plating	◎ (4 m)	◎	○	◎	◎
Hard chrome plating	△ (2 m)	○	X	△	△
Electroless nickel plating	◎ (4 m)	◎	△	X	△
Material equivalent to SUS440C	○ (3.5 m)	○	◎	◎	△

◎: Excellent ○: Suitable in use
△: Not so good for use X: Problem in use

1.4 Measures Against Special Environments

1. In vacuum

● Silver-film plated ball screw

Ball screws that are plated by soft metal (special silver film) as a solid lubricant are developed the application for vacuum environment such as semiconductor manufacturing equipment and surface modification systems.

● Durability test in high vacuum

Test equipment and conditions

Table 4.1 shows ball screw specifications. Fig. 4.1 is a schematic of the testing system in vacuum chamber.

Table 4.2 shows testing conditions.



Photo 4.1 Vacuum testing system

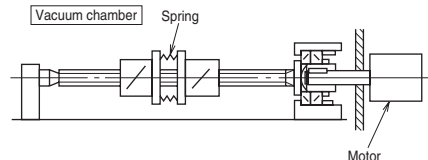

Fig. 4.1 Schematic of the testing system

Table 4.1 Ball screw specifications		
Shaft diameter	12 mm	
Lead	4 mm	
Steel ball diameter	2.381 mm	
Numbers of circuit of balls	2.5 turns, 1 circuit	
Axis load (preload)	29.4 N	
Maximum surface pressure (preload volume)	about 690 MPa	
Material	Shaft	SUS630
	Nut	SUS440C
	Ball return tube	SUS304
	Steel balls	SUS440C
Solid lubricant	Special silver film	

Table 4.2 Testing conditions	
Rotational speed	300 min ⁻¹
Vacuum chamber pressure	1.3×10 ⁻⁵ – 1.3×10 ⁻⁶ Pa
Stroke	160 mm

Evaluation method

It is understood that the rolling bearing with solid lubrication reaches end of life when the lubrication film deteriorates, resulting in sudden rise of friction torque. In this test, ball screw rotation torque was constantly measured to study durability and operation. Results were then evaluated.

Test results

Fig. 4.2 shows two distinctive examples obtained in the torque characteristic test.

Test results of the ball screw (a)

The torque tendency was stable until about 1 × 10⁷ rev. Then the torque characteristics slightly deteriorated. At about 1.35 × 10⁷ rev, the torque suddenly rose. At this point, it was determined that the ball screw reached the end of its life.

Test results of the ball screw (b)

Torque value is a little higher in the test (a). The value is also little unstable. The torque momentarily soared several times during the test (some 10 N·cm). It is thought this is attributable to the repeated peeling/sticking of the surface film made of soft metal (silver, etc.).

When the torque finally soared at 1.13 × 10⁷ rev., it was determined that the ball screw reached the end of its life.

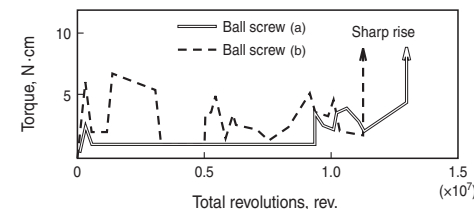

Fig. 4.2 Torque variation

Table 4.3 Ball screw durability

Classification	Ball screw (a)	Ball screw (b)
Total revolutions (rev.)	1.35×10 ⁷	1.13×10 ⁷
Total traveling distance (km)	54.0	45.2
Total traveling hours*(h)	750	628

*) Total traveling hours when operated constantly at 300 min⁻¹

Conclusion

Table 4.3 explains results of the two ball screw durability tests.

From these results and other findings, it is estimated that a life of more than 1 × 10⁷ rev. is possible with a load of about 29.4 N.

Torque may soar momentarily before the ball screw reaches its final life due to peeling/sticking of the surface film made of soft metal like silver. For this reason, it is recommendable to select a drive motor with extra torque capacity.

2. Clean environment

● NSK Clean Grease LG2 and LGU

NSK Clean Grease LG2 is used in clean room for NSK linear guides, ball screws, Monocarriers, XY Modules, Megatorque motors, XY tables, etc. with low-dust emitting specifications. For its low dust emission and high durability, LG2 earns trust and high reputation of semiconductor equipment manufacturers. LG2 is superior in many areas to fluorine greases which are commonly used in clean room.

Features

- Remarkably low dust emission
- Long life -- More than ten times longer than fluoride greases, and equivalent to ordinary greases.
- Excellent rust prevention -- Significantly higher capacity than fluorine greases.
- Low and stable torque -- 20% or less than that of fluorine greases

Table 4.4 Nature of Clean Grease LG2 and LGU

Name	Thickener	Base oil	Base oil kinematic viscosity mm ² /s (40°C)	Consistency	Dropping point °C
Clean Grease LG2	Lithium soap	Synthetic hydrocarbon oil + mineral oil	32	199	201
Clean Grease LGU	Diurea	Synthetic hydrocarbon oil	95.8	201	260

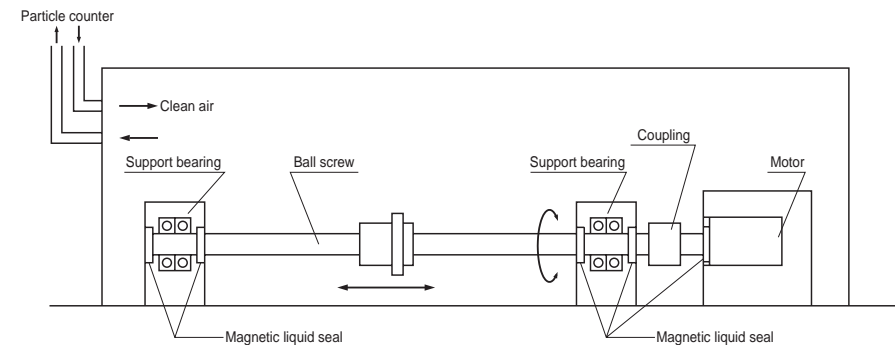

Fig. 4.3 Setting to measure dust generated by ball screw

● Feature 1: Remarkably low dust emission

Compared with fluoride greases, dust emission by LG2 is low and stable for long period of time.

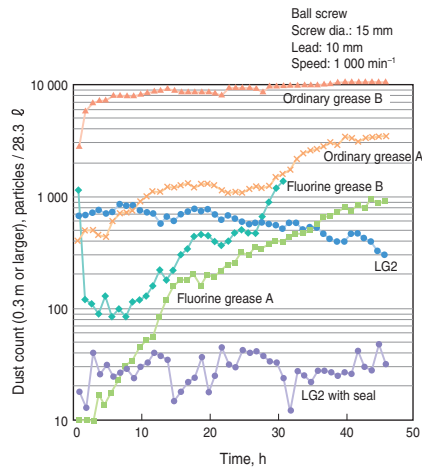

Fig. 4.4 Comparison in dust emission characteristics

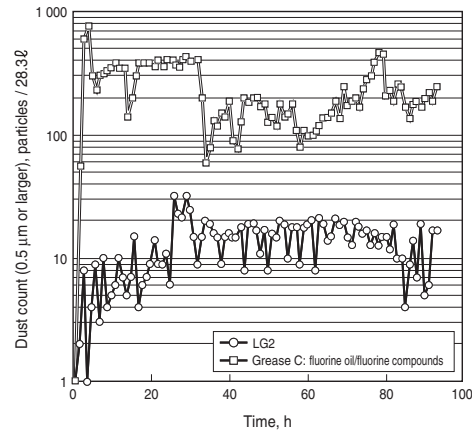

Fig. 4.5 Dust emission from linear guide (Linear guide: LU09)

● Feature 2: Long life

Life is ten times or longer than fluorine greases, and equivalent to ordinary greases. This stretches maintenance intervals.

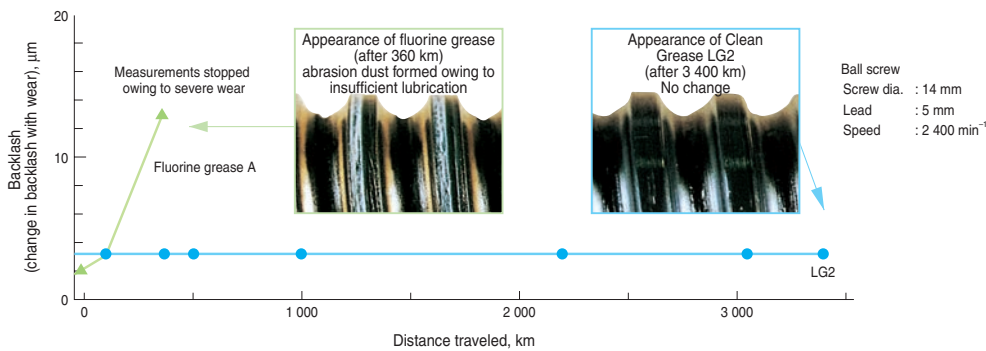

Fig. 4.6 Results of ball screw durability test

● Feature 3: Excellent rust prevention capacity

The rust prevention capacity is significantly higher than fluoride type greases. Handling and preparation for operation are easy.

Ball screw rust prevention test (test conditions: 96 hr at humidity 95%, temperature 70°C)

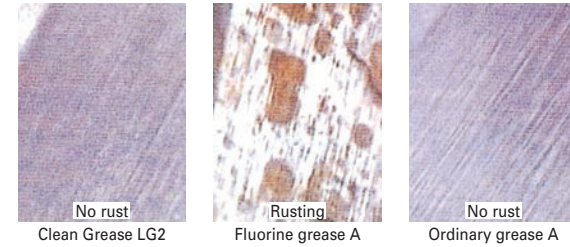

Photo 4.2

Table 4.5 Rust prevention test on bearing

Type	Rusting after 7 days
NSK Clean Grease LG2	No rust
Fluorine grease B	Rusted

Test conditions : 19 mg is sealed in ball bearing 695
: Temp. 90°C, Humidity 60%

Evaluation : Studied by microscope

● Feature 4: Stable torque

Torque is 20% or lower than fluorine greases.

● Total evaluation

Table 4.6 Evaluation

Characteristic	LG2	Fluorine grease	General grease
Dust generation	○	○ - △	△ - X
Torque	○	X	○ - △
Durability	○	△ - X	○
Rust prevention ability	○	△ - X	○

○: Suitable △: Not very suitable X: Problem in use

3. Environment with foreign matters

● NSK K1 lubrication unit (linear guide and ball screw)

Molded oil is made of a lubrication oil and polyolefin which has affinity with the lubrication oil. More than 70% of the mass is lubrication oil.

Molded oil which is formed into NSK K1 lubrication unit effectively seals linear guides, continually supplying lubrication oil. NSK K1 lubrication unit has made it possible to use linear guides in water or powder dust.

NSK K1 lubrication unit for ball screws is also available.

For monocarriers, NSK K1 is equipped as a standard feature.

Features

- Extend maintenance-free intervals
- No contamination of surrounding environment
- Prolong life of the products exposed to water

Refer to pages A38, B577 and C139 for details of NSK K1 lubrication unit.

Ball screw
Screw dia.: 25 mm
Lead: 5 mm
Preload: 294 N

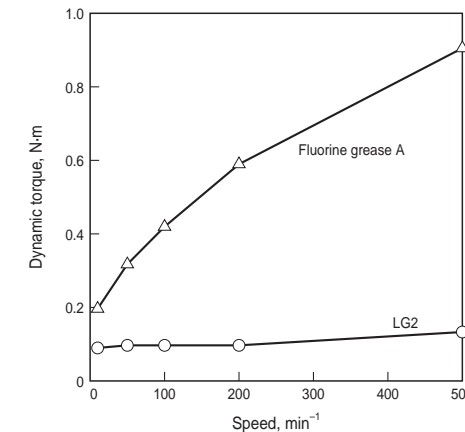

Fig. 4.7 Comparison of torque characteristics

1.5 Table to Cope With Special Environments

1. Linear guides

Series	Model No.	Special environment which linear guide can tolerate					
		Clean	Vacuum	Corrosion	High temp.	Hygienic	High dust proofing
NH	NH15	○		○		○	
	NH20	○		○		○	
	NH25	○	○	○	○	○	
	NH30	○	○	○	○	○	
	NH35	○		○		○	
	NH45	○		○		○	
VH	NH55	○		○		○	
	NH65	○		○		○	
	VH15	○		○		○	○
	VH20	○		○		○	○
	VH25	○		○		○	○
VH	VH30	○		○		○	○
	VH35	○		○		○	○
	VH45	○		○		○	○
	VH55	○		○		○	○
	NS15	○	○	○	○	○	
NS	NS20	○	○	○	○	○	
	NS25	○	○	○	○	○	
	NS30	○	○	○	○*	○	
	NS35	○	○	○	○	○	
	LW17	○		○	○*	○	
LW	LW21	○		○	○*	○	
	LW27	○		○	○	○	
	LW35	○		○	○	○	
	LW50	○		○	○	○	
	PU05	○		○		○	
PU	PU07	○		○		○	
	PU09	○		○		○	
	PU12	○		○		○	
	PU15	○		○		○	
LU	LU05	○		○		○	
	LU07	○		○		○	
	LU09_L	○	○	○	○	○	
	LU09_R	○	○	○	○	○	
	LU12_L	○	○	○	○	○	
LU	LU12_R	○	○	○	○	○	
	LU15	○	○	○	○*	○	

*) Dust-proof parts are not applicable to high-temperature environmental use.

Series	Model No.	Special environment which linear guide can tolerate						
		Clean	Vacuum	Corrosion	High temp.	Hygienic	High dust proofing	
PE	PE05	○		○				
	PE07	○		○				
	PE09	○		○		○		
	PE12	○		○		○		
	PE15	○		○		○		
LE	LE05	○		○				
	LE07	○	○	○	○*			
	LE09_L	○	○	○	○*	○		
	LE09_R	○	○	○	○	○		
	LE12_L	○	○	○	○	○		
	LE12_R	○	○	○	○	○		
	LE15_L	○	○	○	○	○		
Micro-LH	LE15AR	○		○		○		
	LH08	○		○				
	LH10	○		○				
	LH12	○	○	○	○*	○		
	RA15	○		○				
	RA	RA20	○		○			
		RA25	○		○			
		RA30	○		○			
		RA35	○		○			
		RA45	○		○			
		RA55	○		○			
	LA	RA65	○		○			
LA25		○		○				
LA30		○		○				
LA35		○		○				
LA45		○		○				
LA55		○		○				
HA	LA65	○		○				
	HA25	○		○				
	HA30	○		○				
	HA35	○		○				
	HA45	○		○				
HS	HA55	○		○				
	HS15	○		○				
	HS20	○		○				
	HS25	○		○				
	HS30	○		○				
HS	HS35	○		○				

2. Ball screws

Series	Special environment				
	Clean	Vacuum	Rust prevention	High temp.	Foreign matters
KA Series	○	○	○		
For Contaminated environments VSS Type					○
Made-to-order ball screw	○*	○*	○*	○*	○*

*Available in the made-to-order ball screw.

Please consult NSK.

3. Monocarriers

Please consult with NSK for special environmental use.

1.6 Precautions for Handling

Please observe the following precautions to maintain high functions of ball screws and linear motion guide bearings in special environment over a long period.

- Products are washed to remove oil, and wrapped in a way to protect them from moisture. Use the product as soon as possible after opening the package.
- After opening, store the ball slide (random-matching type linear guide) and ball nut (R series ball screw) in a clean, air-tight container such as desiccator with desiccating agent (e.g. silica gel). Do not apply rust preventive oil or paper or product that vaporizes rust preventive agent.
- Wear plastic gloves and handle product in clean place.

2. Lubrication

There are two types of lubricating method -- grease and oil -- for ball screws, linear guides and monocarriers. Use a lubricant agent and method most suitable to condition requirements and purpose to optimize functions of ball screws, linear guides and monocarriers.

In general, lubricants with low base oil kinematic viscosity are used for high-speed operation, in which thermal expansion has a large impact, and in low temperatures.

Lubrication with high base oil kinematic viscosity is used for oscillating operations, low speeds and high temperatures.

The following are lubrication methods using grease and oil.

2.1 Grease Lubrication

Grease lubrication is widely used because it does not require a special oil supply system or piping. Grease lubricants made by NSK are:

- Various types of grease in bellows tubes that can be instantly attached to a grease pump;
- NSK Grease Unit that consists of a hand grease pump and various nozzles. They are compact and easy to use.

1. NSK grease lubricants

Table 1.1 shows the marketed general grease widely used for linear guides, ball screws and monocarrier for specific uses, conditions and purposes.

Table 1.1 Grease lubricant for linear guides, ball screws and monocarriers

Type	Thickener	Base oil	Base oil kinematic viscosity mm ² /s (40°C)	Range of use temperature (°C)	Purpose
AS2	Lithium type	Mineral oil	130	-10 – 110	For general use at high load
PS2	Lithium type	Synthetic oil + synthetic hydrocarbon oil	15.9	-50 – 110	For low temperature and high frequency operation
LR3	Lithium type	Synthetic oil	30	-30 – 130	For high speed, medium load
LG2	Lithium type	Mineral oil + synthetic hydrocarbon oil	32	-20 – 70	For clean environment
LGU	Diurea	Synthetic hydrocarbon oil	95.8	-30 – 120	For clean environment
NF2	Urea composite type	Synthetic hydrocarbon oil	26	-40 – 100	For fretting resistance

(1) NSK Grease AS2

• Features

It is an environmentally friendly and widely used grease for high load application. It is mineral oil based grease containing lithium thickener and several additives. It is superb in load resistance as well as stability in oxidation. It not only maintains good lubrication over a long period of time, but also demonstrates superb capability in retaining water. Even containing a large amount of water, it does not lose grease when it is softened.

• Application

It is a standard grease for general NSK linear guides, ball screws and monocarriers. It is prevalently used in many applications because of its high base oil viscosity, high load resistance, and stability in oxidation.

(2) NSK Grease LR3

• Features

It contains a special synthetic oil for high temperature and stability, and a carefully selected anti-oxidation agent. This grease dramatically increases lubrication life under high temperature conditions. It is used for high speed, medium load. Lubrication life exceeded 2 000 hours in the endurance test at 150°C. Its rust prevention capacity in severe conditions such as water and moist environments is further strengthened.

• Application

It is a standard grease for ball screws PSS type (shaft dia. 15 mm or over), FSS type, FA type (except shaft dia. 10 mm with lead of 4mm and shaft dia. 12 mm with lead of 5 mm) and VFA type. It is ideal for operation with medium load, at high speed such as positioning in high tact material handling equipment.

(3) NSK Grease PS2

• Features

The major base oil component is synthetic oil with mineral oil. It is an excellent lubrication especially for low temperature operation. It is for high speed and light load.

• Application

It is a standard grease for NSK miniature linear guides and ball screws. It is especially superb for low temperature operation, but also functions well in normal temperatures, making it ideal for small equipment with light load.

• Nature

Thickener	Lithium soap base
Base oil	Mineral oil
Consistency	275
Dropping point	181°C
Volume of evaporation	0.24% (99°C, 22 hr)
Copper plate corrosion test	Satisfactory (Method B, 100°C, 24 hr)
Oil separation	2.8% (100°C, 24 hr)
Base oil kinematic viscosity	130 mm ² /s (40°C)

• Nature

Thickener	Lithium soap base
Base oil	Synthetic oil
Consistency	228
Dropping point	208°C
Volume of evaporation	0.58% (99°C, 22 hr)
Copper plate corrosion test	Satisfactory (Method B, 100°C, 24 hr)
Oil separation	1.9% (100°C, 24 hr)
Base oil kinematic viscosity	30 mm ² /s (40°C)

• Nature

Thickener	Lithium soap base
Base oil	Synthetic oil + Synthetic hydrocarbon oil
Consistency	275
Dropping point	190°C
Volume of evaporation	0.60% (99°C, 22 hr)
Copper plate corrosion test	Satisfactory (Method B, 100°C, 24 hr)
Oil separation	3.6% (100°C, 24 hr)
Base oil kinematic viscosity	15.9 mm ² /s (40°C)

(4) NSK Grease LG2

• Features

This grease was developed by NSK to be exclusively used for linear guides and ball screws in clean room. Compared to the fluorine grease which are commonly used in clean room, LG2 has several advantages such as:

- Higher in lubrication function
- Longer lubrication life
- More stable torque (resistant to wear)
- Higher rust prevention.

In dust generation, LG2 is more than equal to fluorine grease in keeping dust volume low. Since the base oil is not a special oil but a mineral oil, LG2 can be handled in the same manner as general greases.

• Application

LG2 is a lubrication grease for rolling element products such as linear guides and ball screws for semiconductor and liquid crystal display (LCD) processing equipment which require a highly clean environment. Because LG2 is exclusively for a clean environment at normal temperatures, however, it cannot be used in a vacuum environment.

Refer to "Special environment" in page D8 for detailed data on superb characteristics of NSK Grease LG2.

• Nature

Thickener	Lithium soap base
Base oil	Mineral oil + Synthetic hydrocarbon oil
Consistency	199
Dropping point	201°C
Volume of evaporation	1.40% (99°C, 22 hr)
Copper plate corrosion test	Satisfactory (Method B, 100°C, 24 hr)
Oil separation	0.8% (100°C, 24 hr)
Base oil kinematic viscosity	32 mm ² /s (40°C)

(5) NSK Grease LGU

• Features

This is a proprietary urea base grease of NSK featuring low dust emission exclusively for ball screws and linear guides which are used in clean rooms.

In comparison with fluorine base grease, which has been used commonly in clean rooms, LGU has better

lubricating property, longer duration of lubricant, better torque variation, much better anti-rust property, and equivalent or better dust emission. In addition, this grease can be handled in the same way as the other common grease because high-grade synthetic oil is used as the base oil.

LGU grease contains much less metallic elements compared to LG2 grease. It can be used in high temperature environment.

• Application

This is exclusive lubrication grease for ball screws and linear guides that are installed in equipment that requires cleanliness, as same as LG2 grease, and it can be used in high temperature range of -30 to 120°C.

This cannot be used in vacuum.

• Nature

Thickener	Diurea
Base oil	Synthetic hydrocarbon oil
Consistency	201
Dropping point	260°C
Volume of evaporation	0.09% (99°C, 22 hr)
Copper plate corrosion test	Satisfactory (Method B, 100°C, 24 hr)
Oil separation	0.6% (100°C, 24 hr)
Base oil kinematic viscosity	95.8 mm ² /s (40°C)

(6) NSK Grease NF2

• Features

It uses high-grade synthetic oil as the base oil and urea base organic compound as the thickener. It has remarkable anti-fretting corrosion property. It can be used in wide temperature range, from low to high, and has superior lubrication life.

• Application

This grease is suitable for ball screws and linear guides of which application include oscillating operations. Allowable temperature range is -40 to 100°C.

• Nature

Thickener	Diurea
Base oil	Synthetic hydrocarbon oil
Consistency	288
Dropping point	260°C
Volume of evaporation	0.22% (99°C, 22 hr)
Copper plate corrosion test	Satisfactory (Method B, 100°C, 24 hr)
Oil separation	0.5% (100°C, 24 hr)
Base oil kinematic viscosity	26 mm ² /s (40°C)

• Precautions for handling

- Wash the linear guides and ball screws to remove oil prior to applying Clean Grease LG2 or LGU, so the grease functions are fully utilized.
- Clean grease is exclusively used for clean environments at normal temperatures.

Note) Refer to NSK Grease Unit Catalog (CAT. No.3317) for details of NSK Grease.

2. Before use of NSK Precision Products

Wipe off the rust preventive oil before use for the products that the oil is applied.

If grease is not applied, apply grease, and move a ball slide or ball nut a few strokes so the grease permeates into the ball slide and inside the nut. (Move the ball slide or the ball nut 5 to 10 times with full stroke.)

Then wipe off the excess grease.

3. How to replenish grease and volume of grease to be replenished

Use grease fitting if exclusive grease supply component is not used. Supply required amount through grease fitting by a grease pump.

Wipe off old grease and accumulated dust before supplying new grease. If grease fitting is not used or there is no oil filler due to the size limitation, apply grease directly to the rail or to the ball groove of the screw shaft. Remove the seal if possible, move a ball slide or ball nut a few strokes so that the grease permeates into the ball slide, nut and inside the slider.

Once grease is replenished, another supply is not required for a long time. But under some operational conditions, it is necessary to periodically replenish grease. The following are replenishing methods.

* When replenishing using a grease pump:

Use a grease pump and fill the inside of ball slide, ball nut and monocarrier slider with grease. Supply grease until it comes out from the ball slide, ball nut or monocarrier slider area. Move ball slide, ball nut or monocarrier slider by hand while filling them with grease, so the grease permeates all areas. Do not operate the machine immediately after replenishing. Always try the system a few times to spread the grease throughout the system and to remove excess grease. Trial operations are necessary because the resistance to sliding force and screw torque greatly increases immediately after replenishment (full-pack state) and may cause problems. The agitating resistance of grease is accountable for this phenomenon. Wipe off excess grease that accumulates at end of rail and screw shaft after trial runs so the grease does not move to other areas.

* When there is an exclusive grease supply system and the volume from the spout can be controlled, the criterion is:

- All at once, replenish the amount that fills about 50% of the internal space of the ball slide or the internal space of the ball nut. This method eliminates waste of grease and is efficient.

Tables 1.2, 1.3 and 1.4 show internal spaces of ball slide, ball nut and monocarrier slider for reference.

Table 1.2 Inside space of the slide of linear guide

NH Series Unit: cm³

Model No.	Series NH	
	High-load type	Super-high-load type
15	3	4
20	6	8
25	9	13
30	13	20
35	22	30
45	47	59
55	80	100
65	139	186

VH Series Unit: cm³

Model No.	Series VH	
	High-load type	Super-high-load type
15	3	4
20	6	8
25	9	13
30	13	20
35	22	30
45	47	59
55	80	100

NS Series Unit: cm³

Model No.	Series NS	
	Medium-load type	High-load type
15	2	3
20	3	4
25	5	8
30	8	12
35	12	19

LW Series Unit: cm³

Model No.	Series LW
	17
21	3
27	7
35	24
50	52

RA Series Unit: cm³

Model No.	Series RA	
	High-load type	Super-high-load type
15	1	1.5
20	2	2.5
25	3	3.5
30	5	6
35	6	8
45	10	13
55	15	20
65	33	42

PU, LU Series Unit: cm³

Model No.	Series PU		Series LU	
	Standard type	High-load type	Standard type	High-load type
05	0.1	-	0.1	-
07	0.1	-	0.1	-
09	0.2	0.3	0.2	0.3
12	0.3	0.4	0.3	0.4
15	0.8	1.1	0.8	1.1

PE, LE Series Unit: cm³

Model No.	Series PE		Series LE		
	Standard type	High-load type	Medium-load type	Standard type	High-load type
05	0.1	-	0.1	0.1	-
07	0.2	-	0.1	0.2	0.3
09	0.4	0.5	0.2	0.4	0.5
12	0.5	0.7	0.3	0.5	0.7
15	1.2	1.6	0.8	1.2	1.6

Miniature LH Series Unit: cm³

Model No.	Series LH
	08
10	0.4
12	1.2

LA Series Unit: cm³

Model No.	Series LA	
	High-load type	Super-high-load type
25	8	12
30	14	18
35	21	29
45	38	48
55	68	86
65	130	177

HA, HS Series Unit: cm³

Model No.	Series HA	Series HS
	15	-
20	-	9
25	16	16
30	27	25
35	42	40
45	67	-
55	122	-

Table 1.3 Inside space of ball nut
Return tube type (single nut)

Unit: cm ³		Unit: cm ³		Unit: cm ³		Unit: cm ³	
Nut model	Inside space	Nut model	Inside space	Nut model	Inside space	Nut model	Inside space
1004 - 2.5	0.8	2005 - 5	4.3	2525 - 1.5	7.5	3225 - 2.5	17
1205 - 2.5	1.2	2010 - 2.5	4.7	2805 - 5	6	3232 - 1.5	15
1210 - 2.5	1.4	2020 - 1.5	4.2	2805 - 10	9	3610 - 5	32
1405 - 2.5	2.2	2504 - 5	3.2	2806 - 5	6	4005 - 10	14
1510 - 2.5	2.3	2505 - 5	5	2806 - 10	9.5	4010 - 5	30
1605 - 2.5	2.6	2506 - 5	7	3205 - 5	7	4012 - 5	34
1616 - 1.5	2.1	2510 - 3	9.5	3206 - 5	9.5	4510 - 5	34
2004 - 5	2.7	2520 - 2.5	12	3210 - 5	22	5010 - 5	37
						5010 - 10	59

Deflector (bridge) type (single nut) Unit: cm³

Nut model	Inside space
2505 - 6	6.5
2510 - 4	10
3205 - 8	9.5
3210 - 6	28
4010 - 8	42
5010 - 8	52

End cap type Unit: cm³

Nut model	Inside space
1520 - 1.5	1.9
2040 - 1	2.8
2550 - 1	4.2

Note:
Nut model: shaft diameter, lead, total number of turns of balls
Please consult NSK for other specifications.
Refer to B110 to B146 for Compact FA Series.

Table 1.4 Inside space of the monocarrier

MCM Series			MCH Series					
Model No.	Unit: cm ³		Model No.	Unit: cm ³		Model No.	Unit: cm ³	
	Lead (mm)	Inside space		Lead (mm)	Inside space		Lead (mm)	Inside space
MCM02	1	0.3	MCM06	5	8.3	MCH06	5	2.8
	2	0.3		10	6.5		MCL06	10
MCM03	1	1		20	5.5	MCH09	20	2.7
	2	0.9	5	11.6	5		5.8	
	10	1.8	10	9.8	10	5.8		
	12	1.7	20	8.7	20	5.6		
MCM05	5	4.2	MCM08	30	4.3	MCH10	10	10.9
	10	4		10	19.4		20	10.1
	20	2.1		20	17.4			
	30	2.0	30	8.8				

4. Intervals of checks and replenishments

Although the grease is of high quality, it gradually deteriorates and its lubrication function diminishes. Also, the grease in the ball slide and ball nut is gradually removed by stroke movement. In some environments, the grease becomes dirty, and foreign

objects may enter. Grease should be replenished depending on frequency of use. The following is a guide of grease replenishment intervals for linear guides and ball screws.

Table 1.5 Intervals of checks and replenishments for grease lubrication

Intervals of checks	Items to check	Intervals of replenishments
3-6 months	Dirt, foreign matters such as cutting chips	Usually once per year. Every 3 000 km for material handling system that travels more than 3 000 km per year. Replenish if checking results warrant it necessary.

- Notes: 1) As a general rule, do not mix greases of different brands.
2) Grease viscosity varies by temperature. Viscosity is particular high in winter due to low temperatures. Pay attention to increases in linear guide and monocarrier sliding resistance and ball screw and monocarrier torque in such conditions.
3) When the ambient temperature is low, or in Winter, if it is difficult to pump out the grease from the container, wait until the grease is softened.
4) In locations where coolant is dispersed or scattered, the emulsification of lubricants and rinsing with water may significantly deteriorate the integrity of the lubricant and efficiency of the grease. Protect the grease unit from coolant by shielding it with a cover, etc.

5. NSK Grease Unit

Supply grease to NSK linear guides and ball screws by manual type hand grease pump. Install grease in

bellows tube to the pump. Several types of grease (80 g) are available.



Grease in bellows tube

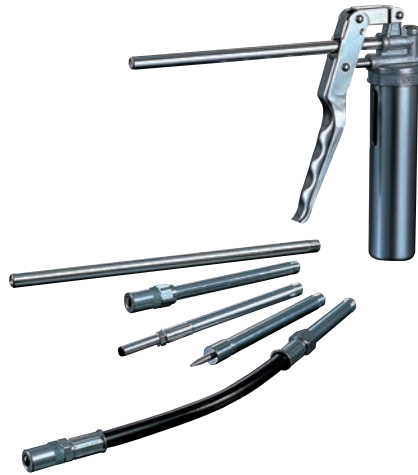

(1) Composition of NSK Grease Unit

Components and grease types are shown below.

NSK Grease Unit		Name	(Tube color)	Reference number
NSK Grease (80 g in a bellows tube)	NSK Grease AS2	NSK Grease AS2	(Brown)	NSK GRS AS2
	NSK Grease PS2	NSK Grease PS2	(Orange)	NSK GRS PS2
	NSK Grease LR3	NSK Grease LR3	(Green)	NSK GRS LR3
	NSK Grease LG2	NSK Grease LG2	(Blue)	NSK GRS LG2
	NSK Grease LGU	NSK Grease LGU	(Yellow)	NSK GRS LGU
	NSK Grease NF2	NSK Grease NF2	(Gray)	NSK GRS NF2
NSK Hand Grease Pump Unit				
NSK Hand Grease Pump (Straight nozzle NSK HGP NZ1 -- One nozzle is provided with hand pump.)				NSK HGP
Grease nozzle (used with hand grease pump)				
NSK straight nozzle				NSK HGP NZ1
NSK chuck nozzle				NSK HGP NZ2
NSK drive-in fitting nozzle				NSK HGP NZ3
NSK point nozzle				NSK HGP NZ4
NSK flexible nozzle				NSK HGP NZ5
NSK flexible extension pipe				NSK HGP NZ6
NSK straight extension pipe				NSK HGP NZ7
NSK nozzle for MCH				NSK HGP NZ8

(2) NSK Greases (80 g in bellows tube)

Refer to pages D14 and D15 for their natures and details.

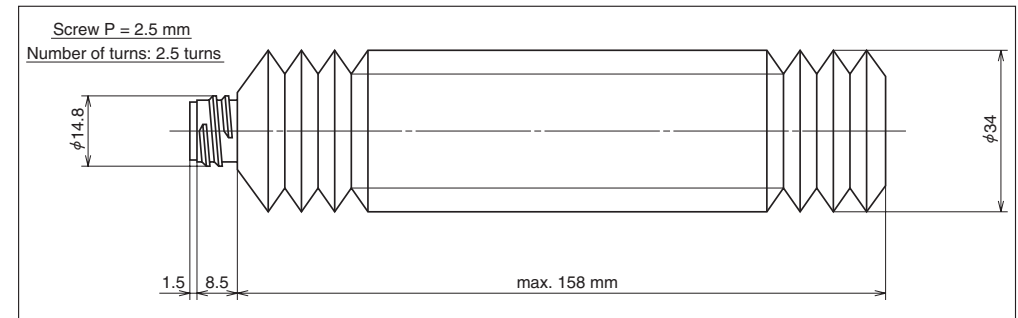

Fig. 1.1 Bellows tube

(3) NSK Manual Grease Pump Unit

a) NSK Hand Grease Pump (Reference number: NSK HGP)

● Features

- Light-weight Can be operated by one hand, yet there is no worry to make a mistake.
- Inserting by high pressure..... Insert at 15 Mpa.
- No leaking Does not leak when held upside down.
- Easy to change grease..... Simply attach grease in bellows tube.
- Remaining grease Can be confirmed through slit on tube.
- Several nozzles Six types of nozzles to choose from.

● Specifications

- Discharge pressure .. 15 Mpa
- Spout volume 0.35 cc/shot
- Mass of main body ... Without nozzle 240 g
Provided nozzle 90 g
- Grease tube outer diameter ϕ 38.1
- Accessory..... Several nozzles for a unique application can be attached

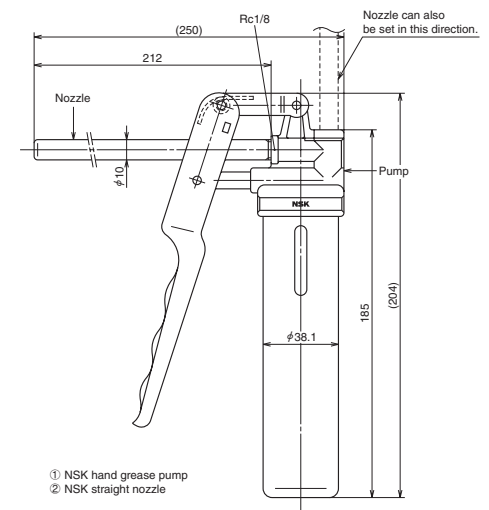

Fig. 1.2 NSK Hand Grease Pump with NSK straight nozzle

*Air is contained in the unopened bellows tube. Try the system tens of times when to use the hand grease pump. The tube will be use after deflated from the tube.

b) Nozzles

Table 1.6 Nozzles that can be attached to NSK Hand Grease Pump

Name	Designation code	Use	Dimensions
NSK straight nozzle	NSK HGP NZ1	Can be used with grease fitting A, B, and C under JIS B1575 standard.	
NSK chuck nozzle	NSK HGP NZ2	Same as above. However, there is no need to press the hand pump because the grease fitting and the nozzle come to contact due to the chucking mechanism at the tip.	
NSK drive-in fitting nozzle	NSK HGP NZ3	Dedicated for the - φ 3 drive-in grease fitting.	
NSK point nozzle	NSK HGP NZ4	Used for linear guides and ball screws which do not have grease fitting. Supplies grease directly to the ball grooves, or through the opening of ball slide or ball slide to inside.	
NSK flexible nozzle	NSK HGP NZ5	The tip of the flexible nozzle is chuck nozzle. The straight nozzle is not available for use.	
NSK flexible extension pipe	NSK HGP NZ6	Flexible extension pipe connects the grease pump and the nozzle	
NSK straight extension pipe	NSK HGP NZ7	Straight extension pipe connects the grease pump and the nozzle.	
NSK nozzle for MCH	NSK HGP NZ8	For MCH Series grease replenishment	

Table 1.7 Grease fittings used for NSK linear guide

Series	Model number	Tap hole for grease fitting	Standard grease fitting	Straight nozzle NZ1	Chuck nozzles NZ2	Drive-in fitting nozzle NZ3	Point nozzle NZ4	Flexible nozzle NZ5
NH	NH15	φ 3	Drive-in type			○		
	NH20, 25, 30, 35*	M6×0.75	B type	○	○			○
	NH45, 55, 65	Rc1/8	B type	○	○			○
VH	VH15	φ 3	Drive-in type			○		
	VH20, 25, 30, 35*	M6×0.75	B type	○	○			○
	VH45, 55	Rc1/8	B type	○	○			○
NS	NS15	φ 3	Drive-in type			○		
	NS20, 25, 30, 35*	M6×0.75	B type	○	○			○
	LW17	φ 3	Drive-in type			○		
LW	LW21, 27, 35*	M6×0.75	B type	○	○			○
	LW50	Rc1/8	B type	○	○			○
	PU05, 07, 09, 12	-	-				○	
PU15	φ 3	Drive-in type			○			
LU05, 07, 09, 12, 15	-	-				○		
PE05, 07, 09, 12	-	-				○		
PE15	φ 3	Drive-in type			○			
LE05, 07, 09, 12, 15	-	-				○		
Miniature LH	LH08, 10	-	-				○	
	LH12	φ 3	Drive-in type			○		
RA	RA15, 20	φ 3	Drive-in type			○		
	RA25, 30, 35*	M6×0.75	B type	○	○			○
	RA45, 55, 65	Rc1/8	B type	○	○			○
LA	LA25, 30, 35*	M6×0.75	B type	○	○			○
	LA45, 55, 65	Rc1/8	B type	○	○			○
HA	HA25, 30, 35*	M6×0.75	B type	○	○			○
	HA45, 55	Rc1/8	B type	○	○			○
HS	HS15	φ 3	Drive-in type			○		
	HS20, 25, 30, 35*	M6×0.75	B type	○	○			○

*) If using a chuck nozzle, avoid interference with table and rail.

Note: 1) For PU, PE, LU, and LE Series, apply grease directly to ball groove, etc. using point nozzle.

2) A long threaded grease fitting is required for NSK linear guides because of dust-proof parts. Please refer to the sections pertaining to the lubrication and dust-proof parts of each series.

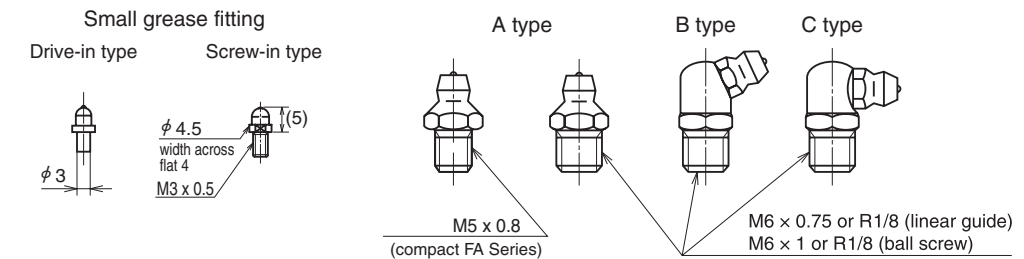

Fig. 1.3 Grease fittings

Table 1.8 Applicable grease nozzle for ball screws

Series		Tap hole for grease fitting	Model No.	Tap hole for grease fitting	Standard grease fitting	Straight nozzle NZ1	Chuck nozzles NZ2	Drive-in fitting nozzle NZ3	Point nozzle NZ4	Flexible nozzle NZ5	
Finished shaft end	Compact FA	High-accuracy, clean	USS	M5x0.8	A type	○	○		○	○	
		General	PSS		A type	○*1	○*1		○	○*1	
		Transfer equipment	FSS		A type	○*1	○*1		○	○*1	
	Miniature, fine lead	MA	Shaft dia. 12 or less Shaft dia. 16 or over	–	–				○		
	Small equipment	FA		M6x1	–	○*2	○*2		○	○*2	
	Machine tools	SA	Shaft dia. 36 or less	M6x1	–	○	○		○	○	
			Shaft dia. 40 or over	Rc1/8	–	○	○		○	○	
	Stainless steel	KA	Shaft dia. 12 or less and lead 2 or less	M3x0.5	–			○	○		
			except above	M6x1	–	○*2	○*2		○	○*2	
	Transfer equipment	VFA	Shaft dia. 12 or less	φ 2.7	–				○		
Shaft dia. 15 or over			φ 3.5	–				○			
RMA			–	–				○			
Blank shaft end	Miniature, fine lead	MS	Shaft dia. 12 or less Shaft dia. 16 or over	–	–				○		
	Small equipment	FS		M6x1	–	○*2	○*2		○	○*2	
	Machine tools	SS	Shaft dia. 36 or less	M6x1	–	○	○		○	○	
			Shaft dia. 40 or over	Rc1/8	–	○	○		○	○	
	Transfer equipment	HSS		M6x1	–	○	○		○	○	
		RMS		–	–				○		
		RNFTL	Shaft dia. 12 or less	M3x0.5	–			○	○		
			Shaft dia. 14 or over	M6x1	–	○	○		○	○	
		RNFBL	Shaft dia. 12 or less	M3x0.5	–			○	○		
			Shaft dia. 14 or over	M6x1	–	○	○		○	○	
RNCT		–	–				○				
RNFCL	Shaft dia. 12 or less	M3x0.5	–			○	○				
	Shaft dia. 15 or over	M6x1	–	○	○		○	○			
RNSTL		M6x1	–	○	○		○	○			

*1 Unavailable for shaft dia. 25 mm *2 If using A type grease fitting, may not install the nozzle.

Notes: 1) Normally, grease fitting is not provided to NSK ball screw except Compact FA Series. Ball nut has a tap hole to install a grease fitting. The user should install a grease fitting if necessary.

2) For M3 x 0.5 tap hole, small fitting (screw-in type) is available. Please contact NSK.

3) VFA type cannot install grease fitting. Apply grease directly to inside the nut through oil hole using point nozzle.

4) MA, RMA, MS, RMS, and RNCT types have no tap hole, apply grease directly to the screw shaft and ball grooves using point nozzle.

Table 1.9 Applicable grease nozzles for Monocarriers

Series	Model No.	Tap hole for grease fitting	Standard grease fitting	Straight nozzle NZ1	Chuck nozzles NZ2	Drive-in fitting nozzle NZ3	Flexible nozzle NZ5	MCH exclusive fitting nozzle NZ8
MCM	MCM02	–	–					
	MCM03,05,08,10	φ 3	Drive-in type			○		○*
	MCM06	M6x0.75	A type	○	○		○	
MCH	MCH06,09,10	φ 3	Drive-in type					○

*) Use of NZ3 is recommended.

2.2 Oil Lubrication

Required amount of new oil is regularly supplied by:

- Manual or automatic intermittent supply system;
- Oil mist lubricating system via piping.

Equipment for oil lubrication is more costly than grease lubrication. However, oil mist lubricating system supplies air as well as oil, raising the inner pressure of the ball slide. This prevents foreign matters from entering, and the air cools the system. Use an oil of high atomizing rate such as ISO VG 32 to 68 for the oil mist lubrication system. ISO VG 68 to 220 are recommended for common intermittent replenishment system. Approximate volume of oil Q for a ball slide of linear guide per hour can be obtained by the following formula.

In case of ball type linear guides except the LA Series

$$Q \geq n/150 \text{ (cm}^3\text{/hr)}$$

In case of LA Series, RA Series

$$Q \geq n/100 \text{ (cm}^3\text{/hr)}$$

n: Linear guide code

e.g. When NH45 is used,

$$n = 45$$

Therefore,

$$Q = 45/150 = 0.3 \text{ cm}^3\text{/hr}$$

Similarly, approximate oil supply volume Q to ball screw can be obtained by the following formula.

$$Q = d/15 \text{ (cm}^3\text{/hr)}$$

d: Nominal shaft diameter of the ball screw

e.g. When the shaft diameter is 50,

$$d = 50$$

Therefore,

$$Q = 50/15 = 3.3 \text{ cm}^3\text{/hr}$$

For oil lubrication by gravity drip, the oil supply position and installation position of the ball slide or ball nut are crucial. In case of linear guide, unless it is installed to a horizontal position, the oil flows only on the down side, and does not spread to all raceway surface. This may cause insufficient lubrication. For ball screw lubrication as well, oil does not spread if the oil orifice is installed at the bottom, causing insufficient lubrication. Please consult NSK to correct such situations prior to use. NSK has internal design which allows oil lubricant to flow throughout the system. **Table 2.1** shows the criterion of intervals of oil checks and replenishments.

Table 2.1 Intervals of checks and replenishments

Method	Intervals of checks	Items to check	Replenishment or intervals of changes
Automatic intermittent supply	Weekly	Volume of oil, dirt, etc.	Replenish at each check. Suitable volume for tank capacity.
Oil bath	Daily before operation	Oil surface	Make a suitable criterion based on consumption

Notes: 1) As with grease lubrication, do not mix oil lubricant with different types.

2) Some components of the linear guide and ball screw are made of plastic. Avoid using an oil that adversely affects synthetic resin.

3) When using oil mist lubricating system, please confirm an oil supply amount at the each outlet part.

3. RoHS Compliant

1. Linear Guides

• Linear Guides listed in the catalog except the products for special environments, are compliant with RoHS.

• Please consult NSK for RoHS of special parts and lubricant provided by customer, and customer-supplied product.

2. Ball Screws

• Ball screws listed in the catalog except the products for special environments, are compliant with RoHS.

3. Monocarriers

• Monocarriers listed in the catalog are compliant with RoHS.

4. Ball Screw Support Bearings

• Ball screw support bearings listed in the catalog are compliant with RoHS.

*For details of country-specific RoHS, contact NSK.

APPENDICES: TABLES



Appendices: Tables

1. Conversion from International Systems of Units (SI) E1
2. Conversion table between N and kgfE3
3. Conversion table between kg and lb E4
4. Hardness conversion table .. E5
5. Variations of shaft used in common fits E7
6. Variations of housing holes in common fits E9

1. Conversion from international system of units (SI)

Comparisons of SI, CGS, and engineering systems of units

Items System of units	Length	Mass	Time	Temperature	Acceleration	Force	Stress	Pressure	Energy	Power
	SI	m	kg	s	K, °C	m/s ²	N	Pa	Pa	J
CGS system	cm	g	s	°C	Gal	dyn	dyn/cm ²	dyn/cm ²	erg	erg/s
Engineering system	m	kgf • s ² /m	s	°C	m/s ²	kgf	kgf/m ²	kgf/m ²	kgf • m	kgf • m/s

Conversion rates from SI system of units

Item	SI unit		Units other than SI units		Conversion rate from SI unit
	Name of unit	Abbreviation	Name of unit	Abbreviation	
Angle	Radian	rad	Degree	°	180/π
			Minute	'	10 800/π
			Second	"	648 000/π
Length	Meter	m	Micron	μ	10 ⁶
			Angstrom	Å	10 ¹⁰
Area	Square meter	m ²	Are	a	10 ⁻²
			Hectare	ha	10 ⁻⁴
Volume	Cubic meter	m ³	Liter	l, L	10 ³
			Deciliter	dl, dL	10 ⁴
Time	Second	s	Minute	min	1/60
			Hour	h	1/3 600
			Day	d	1/86 400
Numbers of vibration numbers of frequency	Hertz	Hz	Cycle	s ⁻¹	1
Rotational speed	Times per second	s ⁻¹	Times per minute	rpm	60
Velocity	Meter per second	m/s	Kilometer per hour	km/h	3 600/1 000
			Knot	kn	3 600/1 852
Acceleration	Meter per square second	m/s ²	Gal	Gal	10 ²
			G	G	1/9.806 65
Mass	Kilogram	kg	Ton	t	10 ⁻³
Force	Newton	N	Weight kilogram	kgf	1/9.806 65
			Weight ton	tf	1/(9.806 65×10 ³)
			Dyne	dyn	10 ⁵
Torque and moment of force	Newton meter	N • m	Weight kilogram meter	kgf • m	1/9.806 65
Stress	Pascal (Newtons per square meter)	Pa (N/m ²)	Weight kilogram per square centimeter	kgf/cm ²	1/(9.806 65×10 ⁴)
			Weight kilogram per square millimeter	kgf/mm ²	1/(9.806 65×10 ⁶)

Prefixes for SI units

Powers of 10	Prefix Name	Code	Powers of 10	Prefix Name	Code
10 ¹⁸	exa	E	10 ⁻¹	deci	d
10 ¹⁵	peta	P	10 ⁻²	centi	c
10 ¹²	tera	T	10 ⁻³	milli	m
10 ⁹	giga	G	10 ⁻⁶	micro	μ
10 ⁶	mega	M	10 ⁻⁹	nano	n
10 ³	kilo	k	10 ⁻¹²	pico	p
10 ²	hecto	h	10 ⁻¹⁵	femto	f
10 ¹	deca	da	10 ⁻¹⁸	atto	a

Conversion rates from SI units (continued from previous page)

Item	SI unit		Units other than SI units		Conversion rate from SI unit
	Name of unit	Abbreviation	Name of unit	Abbreviation	
Pressure	Pascal (newton per square meter)	Pa (N/m ²)	Weight kilogram per square meter	kgf/m ²	1/9.806 65
			Water column meter	mH ₂ O	1/(9.806 65×10 ³)
			Mercurial column millimeter	mmHg	760/(1.013 25×10 ⁵)
			Torr	Torr	760/(1.013 25×10 ⁵)
			Bar	bar	10 ⁻⁵
Energy	Joule (newton meter)	J (N • m)	Erg	erg	10 ⁷
			Calorie (international)	cal _{IT}	1/4.186 8
			Weight kilogram meter	kgf • m	1/9.806 65
			Kilowatt hour	kW • h	1/(3.6×10 ⁶)
			Metric horsepower/hour	PS • h	≈3.776 72×10 ⁻⁷
Electric power, power	Watt (joules per second)	W (J/s)	Weight kilogram meter per second	kgf • m/s	1/9.806 65
			Kilo calorie per hour	kcal/h	1/1.163
			Metric horsepower	PS	≈1/735.498 8
Viscosity, Viscosity index	Pascal second	Pa • s	Poise	P	10
Kinematic viscosity, Kinematic viscosity index	Square meter per second	m ² /s	Stokes	St	10 ⁴
			Centistokes	cSt	10 ⁶
Temperature, Difference in temperature	Kelvin, Celsius degrees	K, °C	Degree	°C	[See Note (1)]
Electrical current, magnetomotive force	Ampere	A	Ampere	A	1
Electrical power, electromotive force	Volt	V	(Watt per ampere)	(W/A)	1
Magnetic field intensity	Ampere per meter	A/m	Oersted	Oe	4π/10 ³
Magnetic flux density	Tesla	T	Gauss	Gs	10 ⁴
			Gamma	γ	10 ⁹
Electrical resistance	Ohm	Ω	(Volt per ampere)	(V/A)	1

Note (1) Conversion from *TK* to *θ °C* is : $\theta = T - 273.15$. To indicate temperature difference: $\Delta T = \Delta\theta$. ΔT and $\Delta\theta$ indicate temperature differences measured by Kelvin and Celsius respectively.

Remarks: Names and abbreviations of the unit in parentheses indicate the definition of the unit shown above the parentheses or left to the parentheses.

Conversion example 1 N = 1/9.806 65 kgf

2. Conversion table between N and kgf

[How to read the table]

To convert 10 N to kgf, locate 10 in the center column in the first block. Locate a corresponding kgf figure in the right side column. You will find 10 N is 1.0197 kgf. To convert 10 kgf to N, locate a figure in N column to its left. You will find 10 kgf is 98.006 N.

$$1 \text{ N} = 0.1019716 \text{ kgf}$$

$$1 \text{ kgf} = 9.80665 \text{ N}$$

N to kgf			kgf to N		
N		kgf	N		kgf
9.8066	1	0.1020	333.43	34	3.4670
19.613	2	0.2039	343.23	35	3.5690
29.420	3	0.3059	353.04	36	3.6710
39.227	4	0.4079	362.85	37	3.7729
49.033	5	0.5099	372.65	38	3.8749
58.840	6	0.6118	382.46	39	3.9769
68.647	7	0.7138	392.27	40	4.0789
78.453	8	0.8158	402.07	41	4.1808
88.260	9	0.9177	411.88	42	4.2828
98.066	10	1.0197	421.69	43	4.3848
107.87	11	1.1217	431.49	44	4.4868
117.68	12	1.2237	441.30	45	4.5887
127.49	13	1.3256	451.11	46	4.6907
137.29	14	1.4279	460.91	47	4.7927
147.10	15	1.5296	470.72	48	4.8946
156.91	16	1.6315	480.53	49	4.9966
166.71	17	1.7335	490.33	50	5.0986
176.52	18	1.8355	500.14	51	5.2006
186.33	19	1.9375	509.95	52	5.3025
196.13	20	2.0394	519.75	53	5.4045
205.94	21	2.1414	529.56	54	5.5065
215.75	22	2.2434	539.37	55	5.6084
225.55	23	2.3453	549.17	56	5.7104
235.36	24	2.4473	558.98	57	5.8124
245.17	25	2.5493	568.79	58	5.9144
254.97	26	2.6513	578.59	59	6.0163
264.78	27	2.7532	588.40	60	6.1183
274.59	28	2.8552	598.21	61	6.2203
284.39	29	2.9572	608.01	62	6.3222
294.20	30	3.0591	617.82	63	6.4242
304.01	31	3.1611	627.63	64	6.5262
313.81	32	3.2631	637.43	65	6.6282
323.62	33	3.3651	647.24	66	6.7301
			657.05	67	6.8321
			666.85	68	6.9341
			676.66	69	7.0360
			686.47	70	7.1380
			696.27	71	7.2400
			706.08	72	7.3420
			715.89	73	7.4439
			725.69	74	7.5459
			735.50	75	7.6479
			745.31	76	7.7498
			755.11	77	7.8518
			764.92	78	7.9538
			774.73	79	8.0558
			784.53	80	8.1577
			794.34	81	8.2597
			804.15	82	8.3617
			813.95	83	8.4636
			823.76	84	8.5656
			833.57	85	8.6676
			843.37	86	8.7696
			853.18	87	8.8715
			862.99	88	8.9735
			872.79	89	9.0755
			882.60	90	9.1774
			892.41	91	9.2794
			902.21	92	9.3814
			912.02	93	9.4834
			921.83	94	9.5853
			931.63	95	9.6873
			941.44	96	9.7893
			951.25	97	9.8912
			961.05	98	9.9932
			970.86	99	10.095

3. Conversion table between kg and lb

[How to read the table]

To convert 10 kg to lb, locate 10 in the center column in the first block. Locate a corresponding lb figure in right column. You will find 10 kg is 22.046 lb. To convert 10 lb to kg, locate the figure in the kg column to the left. You will find 10 lb is 4.536 kg.

$$1 \text{ kg} = 2.2046226 \text{ lb}$$

$$1 \text{ lb} = 0.45359237 \text{ kg}$$

kg to lb			lb to kg		
kg		lb	kg		lb
0.454	1	2.205	15.422	34	74.957
0.907	2	4.409	15.876	35	77.162
1.361	3	6.614	16.329	36	79.366
1.814	4	8.818	16.783	37	81.571
2.268	5	11.023	17.237	38	83.776
2.722	6	13.228	17.690	39	85.980
3.175	7	15.432	18.144	40	88.185
3.629	8	17.637	18.597	41	90.390
4.082	9	19.842	19.051	42	92.594
4.536	10	22.046	19.504	43	94.799
4.990	11	24.251	19.958	44	97.003
5.443	12	26.455	20.412	45	99.208
5.897	13	28.660	20.865	46	101.41
6.350	14	30.865	21.319	47	103.62
6.804	15	33.069	21.772	48	105.82
7.257	16	35.274	22.226	49	108.03
7.711	17	37.479	22.680	50	110.23
8.165	18	39.683	23.133	51	112.44
8.618	19	41.888	23.587	52	114.64
9.072	20	44.092	24.040	53	116.84
9.525	21	46.297	24.494	54	119.05
9.979	22	48.502	24.948	55	121.25
10.433	23	50.706	25.401	56	123.46
10.886	24	52.911	25.855	57	125.66
11.340	25	55.116	26.308	58	127.87
11.793	26	57.320	26.762	59	130.07
12.247	27	59.525	27.216	60	132.28
12.701	28	61.729	27.669	61	134.48
13.154	29	63.934	28.123	62	136.69
13.608	30	66.139	28.576	63	138.89
14.061	31	68.343	29.030	64	141.10
14.515	32	70.548	29.484	65	143.30
14.969	33	72.753	29.937	66	145.51
			30.391	67	147.71
			30.844	68	149.91
			31.298	69	152.12
			31.751	70	154.32
			32.205	71	156.53
			32.659	72	158.73
			33.112	73	160.94
			33.566	74	163.14
			34.019	75	165.35
			34.473	76	167.55
			34.927	77	169.76
			35.380	78	171.96
			35.834	79	174.17
			36.287	80	176.37
			36.741	81	178.57
			37.195	82	180.78
			37.648	83	182.98
			38.102	84	185.19
			38.555	85	187.39
			39.009	86	189.60
			39.463	87	191.80
			39.916	88	194.01
			40.370	89	196.21
			40.823	90	198.42
			41.277	91	200.62
			41.730	92	202.83
			42.184	93	205.03
			42.638	94	207.23
			43.091	95	209.44
			43.545	96	211.64
			43.998	97	213.85
			44.452	98	216.05
			44.906	99	218.26

4. Conversion table of hardness

Rockwell C Scale hardness (1 471 N)	Vickers hardness	Brinell hardness		Rockwell hardness		Shore hardness
		Standard ball	Tungsten carbide ball	A Scale	B Scale	
				Load 588.4 N brale penetrator	Load 980.7 N Diameter 1.5888 mm {1/16 in} sphere	
68	940	—	—	85.6	—	97
67	900	—	—	85.0	—	95
66	865	—	—	84.5	—	92
65	832	—	739	83.9	—	91
64	800	—	722	83.4	—	88
63	772	—	705	82.8	—	87
62	746	—	688	82.3	—	85
61	720	—	670	81.8	—	83
60	697	—	654	81.2	—	81
59	674	—	634	80.7	—	80
58	653	—	615	80.1	—	78
57	633	—	595	79.6	—	76
56	613	—	577	79.0	—	75
55	595	—	560	78.5	—	74
54	577	—	543	78.0	—	72
53	560	—	525	77.4	—	71
52	544	500	512	76.8	—	69
51	528	487	496	76.3	—	68
50	513	475	481	75.9	—	67
49	498	464	469	75.2	—	66
48	484	451	455	74.7	—	64
47	471	442	443	74.1	—	63
46	458	432	432	73.6	—	62
45	446	421	421	73.1	—	60
44	434	409	409	72.5	—	58
43	423	400	400	72.0	—	57
42	412	390	390	71.5	—	56
41	402	381	381	70.9	—	55
40	392	371	371	70.4	—	54
39	382	362	362	69.9	—	52

Rockwell C Scale hardness (1 471 N)	Vickers hardness	Brinell hardness		Rockwell hardness		Shore hardness
		Standard ball	Tungsten carbide ball	A Scale	B Scale	
				Load 588.4 N brale penetrator	Load 980.7 N Diameter 1.5888 mm {1/16 in} sphere	
38	372	353	353	69.4	—	51
37	363	344	344	68.9	—	50
36	354	336	336	68.4	(109.0)	49
35	345	327	327	67.9	(108.5)	48
34	336	319	319	67.4	(108.0)	47
33	327	311	311	66.8	(107.5)	46
32	318	301	301	66.3	(107.0)	44
31	310	294	294	65.8	(106.0)	43
30	302	286	286	65.3	(105.5)	42
29	294	279	279	64.7	(104.5)	41
28	286	271	271	64.3	(104.0)	41
27	279	264	264	63.8	(103.0)	40
26	272	258	258	63.3	(102.5)	38
25	266	253	253	62.8	(101.5)	38
24	260	247	247	62.4	(101.0)	37
23	254	243	243	62.0	100.0	36
22	248	237	237	61.5	99.0	35
21	243	231	231	61.0	98.5	35
20	238	226	226	60.5	97.8	34
(18)	230	219	219	—	96.7	33
(16)	222	212	212	—	95.5	32
(14)	213	203	203	—	93.9	31
(12)	204	194	194	—	92.3	29
(10)	196	187	187	—	90.7	28
(8)	188	179	179	—	89.5	27
(6)	180	171	171	—	87.1	26
(4)	173	165	165	—	85.5	25
(2)	166	158	158	—	83.5	24
(0)	160	152	152	—	81.7	24

5. Deviations of shafts used in common fits

Unit: μm

Classification of diameter (mm)		d6	e6	f6	g5	g6	h5	h6	h7	h8	h9	h10	js5	js6
Over	or less													
—	3	-20 -26	-14 -20	-6 -12	-2 -8	-2 -8	0 -4	0 -6	0 -10	0 -14	0 -25	0 -40	± 2	± 3
3	6	-30 -38	-20 -28	-10 -18	-4 -12	-4 -12	0 -5	0 -8	0 -12	0 -18	0 -30	0 -48	± 2.5	± 4
6	10	-40 -49	-25 -34	-13 -22	-5 -14	-5 -14	0 -6	0 -9	0 -15	0 -22	0 -36	0 -58	± 3	± 4.5
10	18	-50 -61	-32 -43	-16 -27	-6 -17	-6 -17	0 -8	0 -11	0 -18	0 -27	0 -43	0 -70	± 4	± 5.5
18	30	-65 -78	-40 -53	-20 -33	-7 -20	-7 -20	0 -9	0 -13	0 -21	0 -33	0 -52	0 -84	± 4.5	± 6.5
30	50	-80 -96	-50 -66	-25 -41	-9 -20	-9 -25	0 -11	0 -16	0 -25	0 -39	0 -62	0 -100	± 5.5	± 8
50	80	-100 -119	-60 -79	-30 -49	-10 -23	-10 -29	0 -13	0 -19	0 -30	0 -46	0 -74	0 -120	± 6.5	± 9.5
80	120	-120 -142	-72 -94	-36 -58	-12 -27	-12 -34	0 -15	0 -22	0 -35	0 -54	0 -87	0 -140	± 7.5	± 11
120	180	-145 -170	-85 -110	-43 -68	-14 -32	-14 -39	0 -18	0 -25	0 -40	0 -63	0 -100	0 -160	± 9	± 12.5
180	250	-170 -199	-100 -129	-50 -79	-15 -35	-15 -44	0 -20	0 -29	0 -46	0 -72	0 -115	0 -185	± 10	± 14.5
250	315	-190 -222	-110 -142	-56 -88	-17 -40	-17 -49	0 -23	0 -32	0 -52	0 -81	0 -130	0 -210	± 11.5	± 16
315	400	-210 -246	-125 -161	-62 -98	-18 -43	-18 -54	0 -25	0 -36	0 -57	0 -89	0 -140	0 -230	± 12.5	± 18
400	500	-230 -270	-135 -175	-68 -108	-20 -47	-20 -60	0 -27	0 -40	0 -63	0 -97	0 -155	0 -250	± 13.5	± 20
500	630	-260 -304	-145 -189	-76 -120	—	-22 -66	—	0 -44	0 -70	0 -110	0 -175	0 -280	—	± 22
630	800	-290 -340	-160 -210	-80 -130	—	-24 -74	—	0 -50	0 -80	0 -125	0 -200	0 -320	—	± 25
800	1 000	-320 -376	-170 -226	-86 -142	—	-26 -82	—	0 -56	0 -90	0 -140	0 -230	0 -360	—	± 28
1 000	1 250	-350 -416	-195 -261	-98 -164	—	-28 -94	—	0 -66	0 -105	0 -165	0 -260	0 -420	—	± 33
1 250	1 600	-390 -468	-220 -298	-110 -188	—	-30 -108	—	0 -78	0 -125	0 -195	0 -310	0 -500	—	± 39
1 600	2 000	-430 -522	-240 -332	-120 -212	—	-32 -124	—	0 -92	0 -150	0 -230	0 -370	0 -600	—	± 46

		j5	j6	j7	k5	k6	k7	m5	m6	n6	p6	r6	r7	Classification of diameter (mm)	
														Over	or less
± 2	+ 4	+ 6	+ 4	+ 6	+ 10	+ 6	+ 8	+ 10	+ 12	+ 16	+ 20	+ 16	+ 20	—	3
+ 3	+ 6	+ 8	0	0	0	+ 2	+ 2	+ 4	+ 6	+ 10	+ 10	+ 10	+ 10	3	6
- 2	- 2	- 4	+ 1	+ 1	+ 1	+ 4	+ 4	+ 8	+ 12	+ 16	+ 20	+ 20	+ 20	6	10
+ 4	+ 7	+ 10	+ 7	+ 10	+ 16	+ 12	+ 15	+ 19	+ 24	+ 28	+ 34	+ 24	+ 28	10	18
- 2	- 2	- 5	+ 1	+ 1	+ 1	+ 6	+ 6	+ 10	+ 15	+ 19	+ 24	+ 19	+ 23	18	30
+ 5	+ 8	+ 12	+ 9	+ 12	+ 19	+ 15	+ 18	+ 23	+ 29	+ 34	+ 41	+ 29	+ 34	30	50
- 3	- 3	- 6	+ 1	+ 1	+ 1	+ 7	+ 7	+ 12	+ 18	+ 23	+ 28	+ 18	+ 23	50	65
+ 5	+ 9	+ 13	+ 11	+ 15	+ 23	+ 17	+ 21	+ 28	+ 35	+ 41	+ 49	+ 35	+ 41	65	80
- 4	- 4	- 8	+ 2	+ 2	+ 2	+ 8	+ 8	+ 15	+ 22	+ 28	+ 34	+ 22	+ 28	80	100
+ 6	+ 11	+ 15	+ 13	+ 18	+ 27	+ 20	+ 25	+ 33	+ 42	+ 50	+ 59	+ 42	+ 50	100	120
- 5	- 5	- 10	+ 2	+ 2	+ 2	+ 9	+ 9	+ 17	+ 26	+ 34	+ 43	+ 26	+ 34	120	140
+ 6	+ 12	+ 18	+ 15	+ 21	+ 32	+ 24	+ 30	+ 39	+ 51	+ 60	+ 71	+ 51	+ 60	140	160
- 7	- 7	- 12	+ 2	+ 2	+ 2	+ 11	+ 11	+ 20	+ 32	+ 41	+ 51	+ 32	+ 41	160	180
+ 6	+ 13	+ 20	+ 18	+ 25	+ 38	+ 28	+ 35	+ 45	+ 59	+ 73	+ 86	+ 59	+ 73	180	200
- 9	- 9	- 15	+ 3	+ 3	+ 3	+ 13	+ 13	+ 23	+ 37	+ 46	+ 56	+ 37	+ 46	200	225
+ 7	+ 14	+ 22	+ 21	+ 28	+ 43	+ 28	+ 35	+ 45	+ 59	+ 73	+ 86	+ 59	+ 73	225	250
- 11	- 11	- 18	+ 3	+ 3	+ 3	+ 15	+ 15	+ 27	+ 43	+ 52	+ 62	+ 43	+ 52	250	280
+ 7	+ 16	+ 25	+ 24	+ 33	+ 50	+ 37	+ 46	+ 60	+ 79	+ 93	+ 108	+ 79	+ 93	280	315
- 13	- 13	- 21	+ 4	+ 4	+ 4	+ 17	+ 17	+ 31	+ 50	+ 65	+ 80	+ 50	+ 65	315	355
+ 7	+ 16	+ 25	+ 27	+ 36	+ 56	+ 43	+ 52	+ 66	+ 88	+ 106	+ 126	+ 88	+ 106	355	400
- 16	± 16	± 26	+ 4	+ 4	+ 4	+ 20	+ 20	+ 34	+ 56	+ 73	+ 94	+ 56	+ 73	400	450
+ 7	± 18	+ 29	+ 29	+ 40	+ 61	+ 46	+ 57	+ 73	+ 98	+ 119	+ 146	+ 98	+ 119	450	500
- 18	± 18	- 28	+ 4	+ 4	+ 4	+ 21	+ 21	+ 37	+ 62	+ 82	+ 108	+ 62	+ 82	500	560
+ 7	± 20	+ 31	+ 32	+ 45	+ 68	+ 50	+ 63	+ 80	+ 108	+ 132	+ 166	+ 108	+ 132	560	630
- 20	± 20	- 32	+ 5	+ 5	+ 5	+ 23	+ 23	+ 40	+ 68	+ 94	+ 126	+ 68	+ 94	630	710
—	—	—	—	+ 44	+ 70	—	+ 70	+ 88	+ 122	+ 155	+ 199	+ 122	+ 155	710	800
—	—	—	—	0	0	—	+ 80	+ 100	+ 138	+ 175	+ 225	+ 138	+ 175	800	900
—	—	—	—	+ 50	+ 80	—	+ 80	+ 100	+ 138	+ 185	+ 235	+ 138	+ 185	900	1 000
—	—	—	—	0	0	—	+ 90	+ 112	+ 156	+ 200	+ 266	+ 156	+ 200	1 000	1 120
—	—	—	—	+ 56	+ 90	—	+ 90	+ 112	+ 156	+ 200	+ 276	+ 156	+ 200	1 120	1 250
—	—	—	—	0	0	—	+ 106	+ 132	+ 186	+ 240	+ 316	+ 186	+ 240	1 250	1 400
—	—	—	—	+ 66	+ 105	—	+ 106	+ 132	+ 186	+ 240	+ 326	+ 186	+ 240	1 400	1 600
—	—	—	—	0	0	—	+ 126	+ 156	+ 218	+ 282	+ 378	+ 218	+ 282	1 600	1 800
—	—	—	—	+ 78	+ 125	—	+ 126	+ 156	+ 218	+ 282	+ 382	+ 218	+ 282	1 800	2 000
—	—	—	—	0	0	—	+ 150	+ 184	+ 262	+ 342	+ 462	+ 262	+ 342	2 000	
—	—	—	—	+ 92	+ 150	—	+ 150	+ 184	+ 262	+ 342	+ 462	+ 262	+ 342		
—	—	—	—	0	0	—	+ 58	+ 92	+ 126	+ 170	+ 226	+ 126	+ 170		
—	—	—	—	0	0	—	+ 58	+ 92	+ 126	+ 170	+ 226	+ 126	+ 170		

6. Deviations of holes used in common fits

Unit: μm

Classification of diameter (mm)		E6		F6		F7		G6		G7		H6		H7		H8		J6		J7		JS6		JS7	
Over	or less																								
—	3	+20	+14	+12	+6	+16	+6	+12	+8	+2	+12	+2	+6	+10	+4	+14	+2	+4	-4	-6	±3	±5			
3	6	+28	+20	+18	+10	+22	+10	+16	+12	+4	+16	+4	+8	+12	+18	+18	+5	±6	-3	±6	±4	±6			
6	10	+34	+25	+22	+13	+28	+13	+20	+14	+5	+20	+5	+9	+15	+22	+22	+5	+8	-4	-7	±4.5	±7.5			
10	18	+43	+32	+27	+16	+34	+16	+24	+17	+6	+24	+6	+11	+18	+27	+27	+6	+10	-5	-8	±5.5	±9			
18	30	+53	+40	+33	+20	+41	+20	+28	+20	+7	+28	+7	+13	+21	+33	+33	+8	+12	-5	-9	±6.5	±10.5			
30	50	+66	+50	+41	+25	+50	+25	+34	+25	+9	+34	+9	+16	+25	+39	+39	+10	+14	-6	-11	±8	±12.5			
50	80	+79	+60	+49	+30	+60	+30	+40	+29	+10	+40	+10	+19	+30	+46	+46	+13	+18	-6	-12	±9.5	±15			
80	120	+94	+72	+58	+36	+71	+36	+47	+34	+12	+47	+12	+22	+35	+54	+54	+16	+22	-6	-13	±11	±17.5			
120	180	+110	+85	+68	+43	+83	+43	+54	+39	+14	+54	+14	+25	+40	+63	+63	+18	+26	-7	-14	±12.5	±20			
180	250	+129	+100	+79	+50	+96	+50	+61	+44	+15	+61	+15	+29	+46	+72	+72	+22	+30	-7	-16	±14.5	±23			
250	315	+142	+110	+88	+56	+108	+56	+69	+49	+17	+69	+17	+32	+52	+81	+81	+25	+36	-7	-16	±16	±26			
315	400	+161	+125	+98	+62	+119	+62	+75	+54	+18	+75	+18	+36	+57	+89	+89	+29	+39	-7	-18	±18	±28.5			
400	500	+175	+135	+108	+68	+131	+68	+83	+60	+20	+83	+20	+40	+63	+97	+97	+33	+43	-7	-20	±20	±31.5			
500	630	+189	+145	+120	+76	+146	+76	+92	+66	+22	+92	+22	+44	+70	+110	+110	—	—	—	—	±22	±35			
630	800	+210	+160	+130	+80	+160	+80	+104	+74	+24	+104	+24	+50	+80	+125	+125	—	—	—	—	±25	±40			
800	1 000	+226	+170	+142	+86	+176	+86	+116	+82	+26	+116	+26	+56	+90	+140	+140	—	—	—	—	±28	±45			
1 000	1 250	+261	+195	+164	+98	+203	+98	+133	+94	+28	+133	+28	+66	+105	+165	+165	—	—	—	—	±33	±52.5			
1 250	1 600	+298	+220	+188	+110	+235	+110	+155	+108	+30	+155	+30	+78	+125	+195	+195	—	—	—	—	±39	±62.5			
1 600	2 000	+332	+240	+212	+120	+270	+120	+182	+124	+32	+182	+32	+92	+150	+230	+230	—	—	—	—	±46	±75			

Classification of diameter (mm)		K5		K6		K7		M5		M6		M7		N5		N6		N7		P6		P7		Classification of diameter (mm)	
Over	or less																							Over	or less
—	3	0	-4	0	-6	0	-10	-2	-6	-2	-8	-2	-12	-4	-8	-4	-14	-4	-14	-6	-12	-6	-16	—	3
3	6	0	-5	+2	-6	+3	-9	-3	-8	-1	-9	0	-12	-7	-12	-5	-16	-4	-16	-9	-17	-8	-20	3	6
6	10	+1	-5	+2	-7	+5	-10	-4	-10	-3	-12	0	-15	-8	-14	-7	-19	-4	-19	-12	-21	-9	-24	6	10
10	18	+2	-6	+2	-9	+6	-12	-4	-12	-4	-15	0	-18	-9	-17	-9	-23	-5	-23	-15	-26	-11	-29	10	18
18	30	+1	-8	+2	-11	+6	-15	-5	-14	-4	-17	0	-21	-12	-21	-11	-28	-7	-28	-18	-31	-14	-35	18	30
30	50	+2	-9	+3	-13	+7	-18	-5	-16	-4	-20	0	-25	-13	-24	-12	-33	-8	-33	-21	-37	-17	-42	30	50
50	80	+3	-10	+4	-15	+9	-21	-6	-19	-5	-24	0	-30	-15	-28	-14	-39	-9	-39	-26	-45	-21	-51	50	80
80	120	+2	-13	+4	-18	+10	-25	-8	-23	-6	-28	0	-35	-18	-33	-16	-45	-10	-45	-30	-52	-24	-59	80	120
120	180	+3	-15	+4	-21	+12	-28	-9	-27	-8	-33	0	-40	-21	-39	-20	-52	-12	-52	-36	-61	-28	-68	120	180
180	250	+2	-18	+5	-24	+13	-33	-11	-31	-8	-37	0	-46	-25	-45	-22	-60	-14	-60	-41	-70	-33	-79	180	250
250	315	+3	-20	+5	-27	+16	-36	-13	-36	-9	-41	0	-52	-27	-50	-25	-66	-14	-66	-47	-79	-36	-88	250	315
315	400	+3	-22	+7	-29	+17	-40	-14	-39	-10	-46	0	-57	-30	-55	-26	-73	-16	-73	-51	-87	-41	-98	315	400
400	500	+2	-25	+8	-32	+18	-45	-16	-43	-10	-50	0	-63	-33	-60	-27	-80	-17	-80	-55	-95	-45	-108	400	500
500	630	—	—	0	-44	0	-70	—	—	-26	-70	-26	-96	—	—	-44	-114	-44	-114	-78	-122	-78	-148	500	630
630	800	—	—	0	-50	0	-80	—	—	-30	-80	-30	-110	—	—	-50	-130	-50	-130	-88	-138	-88	-168	630	800
800	1 000	—	—	0	-56	0	-90	—	—	-34	-90	-34	-124	—	—	-56	-146	-56	-146	-100	-156	-100	-190	800	1 000
1 000	1 250	—	—	0	-66	0	-105	—	—	-40	-106	-40	-145	—	—	-66	-171	-66	-171	-120	-186	-120	-225	1 000	1 250
1 250	1 600	—	—	0	-78	0	-125	—	—	-48	-126	-48	-173	—	—	-78	-203	-78	-203	-140	-218	-140	-265	1 250	1 600
1 600	2 000	—	—	0	-92	0	-150	—	—	-58	-150	-58	-208	—	—	-92	-242	-92	-242	-170	-262	-170	-320	1 600	2 000

Worldwide Sales Offices

P: Phone F: Fax ☆: Head Office

NSK LTD.-HEADQUARTERS, TOKYO, JAPAN

Nissel Bldg., 1-6-3 Ohsaki, Shinagawa-ku, Tokyo 141-8560, Japan
INDUSTRIAL MACHINERY BUSINESS DIVISION-HEADQUARTERS
P: +81-3-3779-7227 F: +81-3-3779-7644
AUTOMOTIVE BUSINESS DIVISION-HEADQUARTERS
P: +81-3-3779-7189 F: +81-3-3779-7917

●Africa

South Africa:

NSK SOUTH AFRICA (PTY) LTD.

SANDTON 25 Galaxy Avenue, Linbro Business Park, Sandton 2146, South Africa
P: +27-11-458-3600 F: +27-11-458-3608

●Asia and Oceania

Australia:

NSK AUSTRALIA PTY. LTD.

MELBOURNE ☆ 100 Logis Boulevard, Dandenong South, Victoria, 3175, Australia
P: +61-3-9765-4400 F: +61-3-9765-4466
SYDNEY Suite A315, 20 Lexington Drive, Bella Vista, New South Wales, 2153, Australia
P: +61-2-9839-2300 F: +61-2-8824-5784
BRISBANE 1/69 Selhurst Street, Coopers Plains, Queensland 4108, Australia
P: +61-7-3347-2600 F: +61-7-3345-5376
PERTH Unit 1, 71 Tacoma Circuit, Canning Vale, Western Australia 6155, Australia
P: +61-8-9256-5000 F: +61-8-9256-1044

New Zealand:

NSK NEW ZEALAND LTD.

AUCKLAND 3 Te Apunga Place, Mt. Wellington, Auckland 1060, New Zealand
P: +64-9-276-4992 F: +64-9-276-4082

China:

NSK (SHANGHAI) TRADING CO., LTD.

JIANGSU No.8 NSK Rd., Huaqiao Economic Development Zone, Kunshan, Jiangsu, China (215332)
P: +86-512-5796-3000 F: +86-512-5796-3300

NSK (CHINA) INVESTMENT CO., LTD.

JIANGSU ☆ No.8 NSK Rd., Huaqiao Economic Development Zone, Kunshan, Jiangsu, China (215332)
P: +86-512-5796-3000 F: +86-512-5796-3300

BEIJING

Room 1906, Beijing Fortune Bldg., No.5 Dong San Huan Bei Lu, Chao Yang District, Beijing, China (100004)
P: +86-10-6590-8161 F: +86-10-6590-8166

TIAN JIN

Room 06, 09F The Exchange Tower 2, No. 189 Nanjing Road, Heping District, Tianjin, China (300050)
P: +86-22-8319-5030 F: +86-22-8319-5033

CHANGCHUN

Room 902-03, Changchun Hongwell International Plaza, No.3299 Renmin Street, Changchun, Jilin, China (130061)
P: +86-431-8898-8682 F: +86-431-8898-8670

SHENYANG

Room 1101, China Resources Building, No. 286 Qingnian Street, Heping District, Shenyang Liaoning, China (110004)
P: +86-24-2334-2868 F: +86-24-2334-2058

DALIAN

Room 1805 Xiwang Tower, No.136 Zhongshan Road, Zhongshan District, Dalian, Liaoning, China (116001)
P: +86-411-8800-8168 F: +86-411-8800-8160

NANJING

Room A1 22F, Golden Eagle International Plaza, No.89 Hanzhong Road, Nanjing, Jiangsu, China (210029)
P: +86-25-8472-6671 F: +86-25-8472-6687

FUZHOU

Room 1801-1811, B1#1A Class Office Building, Wanda Plaza, No.8 Aojiang Road, Fuzhou, China (350009)
P: +86-591-8380-1030 F: +86-591-8380-1225

WUHAN

Room 1110, New World International Trade Tower I, No.568 Jianshe Road, Wuhan, Hubei, China (430000)
P: +86-27-8556-9630 F: +86-27-8556-9615

QINGDAO

Room 802, Fangyong International Plaza, No.26 Xianggang Zhong Road, Shinan District, Qingdao, Shandong, China (266071)
P: +86-532-5568-3877 F: +86-532-5568-3876

GUANGZHOU

Room 1011-16, Yuexiu Financial Tower, No.28 Zhuijiang Road East, Zhuijiang New Town, Guangzhou, Guangdong, China (510627)
P: +86-20-3817-7800 F: +86-20-3786-4501

CHANGSHA

Room 1048, 10/F, Zhongtian Plaza, No.786 WuyiRoad, Changsha, Hunan, China (410005)
P: +86-731-8571-3100 F: +86-731-8571-3255

LUOYANG

Room 1108, Fangda Hotel, 6 XIYuan Road, LuoYang HeNan, China (471003)
P: +86-379-6069-6188 F: +86-379-6069-6180

XIAN

Room 1007, B Changan Metropolis Center88 Nanguanzheng Steet, Xi'an, Shanxi, China (710068)
P: +86-29-8785-1896 F: +86-29-8765-1895

CHONGQING

Room 2306, Unit B, No.137, Keyuan 2nd Road, Julongpo District, Chongqing, China (400039)
P: +86-23-6806-5310 F: +86-23-6806-5292

CHENGDU

Room1117, Lippo Tower, No.82 North Kehua Road, Chengdu, Sichuan, China (610041)
P: +86-28-8528-3680 F: +86-28-8528-3690

NSK CHINA SALES CO., LTD.

JIANGSU No.8 NSK Rd., Huaqiao Economic Development Zone, Kunshan, Jiangsu, China (215332)
P: +86-512-5796-3000 F: +86-512-5796-3300

NSK HONG KONG LTD.

HONG KONG ☆ Suite 705, 7th Floor, South Tower, World Finance Centre, Harbour City, T.S.T, Kowloon, Hong Kong, China
P: +852-2739-9933 F: +852-2739-9323
Room 624-626, 6/F, Kerry Center, Renminnan Road, Shenzhen, Guangdong, China
P: +86-755-25904886 F: +86-755-25904883

SHENZHEN

Taiwan:

TAIWAN NSK PRECISION CO., LTD.

TAIPEI ☆ 11F., No.87, Song Jiang Rd., Jhongsan District, Taipei City 104, Taiwan
P: +886-2-2509-3305 F: +886-2-2509-1393
TAICHUNG 3F., -2, No. 540, Sec.3, Taiwan Blvd., Xitun Dist., Taichung City 407, Taiwan
P: +886-4-2708-3393 F: +886-4-2708-3395
TAINAN 5F, No.8, Daye 1st Rd., Southern Taiwan Science Park, Tainan City 741, Taiwan
P: +886-6-505-5861 F: +886-6-505-5061

TAIWAN NSK TECHNOLOGY CO., LTD.

TAIPEI ☆ 11F., No.87, Song Jiang Rd., Jhongsan District, Taipei City 104, Taiwan
P: +886-2-2509-3305 F: +886-2-2509-1393
TAICHUNG 10F-3, No.925, Sec.4, Taiwan Blvd., Xitun Dist., Taichung City 407, Taiwan
P: +886-4-2358-2945 F: +886-4-2358-7682
TAINAN 5F, No.8, Daye 1st Rd., Southern Taiwan Science Park, Tainan City 741, Taiwan
P: +886-6-505-5861 F: +886-6-505-5061

India:

NSK INDIA SALES CO.PVT.LTD.

CHENNAI ☆ TVH Baliccia Towers, 2nd Floor, Block I, No.71/1, MRC Nagar Main Road, MRC Nagar, Chennai-600 028, Tamil Nadu, India
P: +91-44-2847-9600 F: +91-44-2847-9601
GURGAON Unit No-202, 2nd Floor, Block-A, Iris Tech Park, Sector-48, Sohna Road, Gurgaon-122018, Haryana, India
P: +91-124-4104-530 F: +91-124-4104-532
MUMBAI 321, 'A' Wing, Ahura Centre, 82, Mahakali Caves Road, Andheri (East), Mumbai -400 093, India
P: +91-22-2838-7787 F: +91-22-2838-5191

Indonesia:

PT. NSK INDONESIA

JAKARTA Summitms II, 6th Floor, Jl. Jend Sudirman Kav. 61-62, Jakarta 12190, Indonesia
P: +62-21-252-3458 F: +62-21-252-3223

Korea:

NSK KOREA CO., LTD.

SEOUL Posco Center (West Wing) 9F, Western-wing, 440, Teheran-ro, Gangnam-gu, Seoul, 135-777, Korea
P: +82-2-3287-0300 F: +82-2-3287-0345

Malaysia:

NSK BEARINGS (MALAYSIA) SDN. BHD.

SHAH ALAM ☆ No. 2, Jalan Pemaju, U1/15, Seksyen U1, Hicom Glenmarie Industrial Park, 40150 Shah Alam, Selangor, Malaysia
P: +60-3-7803-8859 F: +60-3-7806-5982
PRAI No.24, Jalan kikik, Taman Inderawasih, 13600 Prai, Penang, Malaysia
P: +60-4-3902275 F: +60-4-3991830
JOHOR BAHRU 88 Jalan Ros Merah 2/17, Taman Johor Jaya, 81100 Johor Bahru, Johor, Malaysia
P: +60-7-3546290 F: +60-7-3546291
IPOH Gr. Floor, 89 Jalan Bendahara, 31650 Ipoh, Perak, Malaysia
P: +60-5-2555000 F: +60-5-2553373

Philippines:

NSK REPRESENTATIVE OFFICE

MANILA 8th Floor The Salcedo Towers 169 H.V. dela Costa St., Salcedo Village Makati City, Philippines 1227
P: +63-2-893-9543 F: +63-2-893-9173
SINGAPORE 238A, Thomson Road, #24-01/05, Novena Square Tower A, Singapore 307684
P: +65-6496-8000 F: +65-6250-5845

NSK SINGAPORE (PRIVATE) LTD.

SINGAPORE 238A, Thomson Road, #24-01/05, Novena Square Tower A, Singapore 307684
P: +65-6496-8000 F: +65-6250-5845

Thailand:

NSK BEARINGS (THAILAND) CO.,LTD.

BANGKOK 26 Soi Omnuch 55/1 Pravet Subdistrict, Pravet District, Bangkok 10250, Thailand
P: +86-2320-2555 F: +66-2320-2826

Vietnam:

NSK VIETNAM CO., LTD.

HANOI Techno Center, Room 204-205, Thang Long Industrial Park, Dong Anh District, Hanoi, Vietnam
P: +84-4-3955-0159 F: +84-4-3955-0158
HO CHI MINH CITY Suite 307, Metropolitan Building, 235 Dong Khoi Street, District 1,HCMC, Vietnam
P: +84-8-3822-7907 F: +84-8-3822-7910

NSK REPRESENTATIVE OFFICE

HO CHI MINH CITY Suite 307, Metropolitan Building, 235 Dong Khoi Street, District 1,HCMC, Vietnam
P: +84-8-3822-7907 F: +84-8-3822-7910

Worldwide Sales Offices

P: Phone F: Fax ☆: Head Office

●Europe

United Kingdom:

NSK EUROPE LTD. (EUROPEAN HEADQUARTERS)

MADDENHEAD Belmont Place, Belmont Road, Maidenhead, Berkshire SL6 6TB, U.K.
P: +44-1628-509-800 F: +44-1628-509-808

NSK UK LTD.

NEWARK Northern Road, Newark, Nottinghamshire NG24 2JF, U.K.
P: +44-1636-605-123 F: +44-1636-605-000

France:

NSK FRANCE S.A.S.

PARIS Quartier de l'Europe, 2 Rue Georges Guynemer, 78283 Guyancourt, France
P: +33-1-30-57-39-39 F: +33-1-30-57-00-01

Germany:

NSK DEUTSCHLAND GMBH

DUSSELDORF ☆ Harkortstrasse 15, D-40880 Ratingen, Germany
P: +49-2102-4810 F: +49-2102-4812-290
STUTTGART Liebknechtstrasse 33, D-70565 Stuttgart-Vaihingen, Germany
P: +49-711-79082-0 F: +49-711-79082-289
WOLFSBURG Tischlerstrasse 3, D-38440 Wolfsburg, Germany
P: +49-5361-27647-10 F: +49-5361-27647-70

Italy:

NSK ITALIA S.P.A.

MILANO Via Garibaldi 215, Garbagnate Milanese (Milano) 20024, Italy
P: +39-299-5191 F: +39-299-025778

Netherlands:

NSK EUROPEAN DISTRIBUTION CENTRE B.V.

TILBURG De Kroonstraat 38, 5048 AP Tilburg, Netherlands
P: +31-13-4647647 F: +31-13-4647648

Poland:

NSK REPRESENTATIVE OFFICE

WARSAW Ul. Migdalowa 4/73, 02-796, Warsaw, Poland
P: +48-22-645-1525 F: +48-22-645-1529

Russia:

NSK POLSKA SP. Z O.O.

SAINT-PETERSBURG Office I, Bldg 29, 18th Line of Vasilievskiy Ostrov, Saint-Petersburg, Russia, 199178
P: +7-812-332-5071 F: +7-812-332-5072

Spain:

NSK SPAIN S.A.

BARCELONA C/Tarragona, 161 Cuerpo Bajo, 2a Planta, 08014, Barcelona, Spain
P: +34-93-289-2763 F: +34-93-433-5776

Turkey:

NSK RULMANLARI ORTA DOGU TIC. LTD. STI.

ISTANBUL 19 Mayıs Mah. Ataturk Cad., Ulya Akgen Is Merkezi No: 68 Kat. 6, P.K. : 34736, Kozyatagi-Istanbul, Turkey
P: +90-216-477-7111 F: +90-216-477-7174

United Arab Emirates:

NSK BEARINGS GULF TRADING CO.

DUBAI JAFZA View 19, Floor 24 Office LB192402/3, PO Box 262163, DownTown Jebel Ali, Dubai, UAE
P: +971-4-804-8207 F: +971-4-884-7227

●North and South America

United States of America:

NSK AMERICAS, INC. (AMERICAN HEADQUARTERS)

ANN ARBOR 4200 Goss Road, Ann Arbor, Michigan 48105, U.S.A.
P: +1-734-913-7500 F: +1-734-913-7511

NSK CORPORATION

ANN ARBOR 4200 Goss Road, Ann Arbor, Michigan 48105, U.S.A.
P: +1-734-913-7500 F: +1-734-913-7511

NSK PRECISION AMERICA, INC.

FRANKLIN ☆ 3450 Bearing Drive, Franklin, Indiana 46131, U.S.A.
P: +1-317-738-5000 F: +1-317-738-5050

SAN JOSE

780 Montague Expressway, Suite 505, San Jose, California, 95131, U.S.A.
P: +1-408-944-9400 F: +1-408-944-9405

NSK LATIN AMERICA, INC.

MIAMI 3470 NW 82nd Avenue Suite 625, Miami FL 33122, U.S.A.
P: +1-305-477-0605 F: +1-305-477-0377

Canada:

NSK CANADA INC.

TORONTO ☆ 5585 McAdam Road, Mississauga, Ontario, Canada L4Z 1N4
P: +1-905-890-0740 F: +1-800-800-2788

MONTREAL

2150-32E Avenue Lachine, Quebec, Canada H8T 3H7
P: +1-514-633-1220 F: +1-800-800-2788

VANCOUVER

3353 Wayburne Drive, Burnaby, British Columbia, Canada V5G 4L4
P: +1-877-994-6675 F: +1-800-800-2788

Argentina:

NSK ARGENTINA SRL

BUENOS AIRES Garcia del Rio 2477 Piso 7 Oficina "A" (1429) Buenos Aires-Argentina
P: +54-11-4704-5100 F: +54-11-4704-0033

<As of February 2018>

For the latest information, please refer to the NSK website, www.nsk.com

NSK Ltd. has a basic policy not to export any products or technology designated as controlled items by export-related laws. When exporting the products in this brochure, the laws of the exporting country must be observed. Specifications are subject to change without notice and without any obligation on the part of the manufacturer. Every care has been taken to ensure the accuracy of the data contained in this brochure, but no liability can be accepted for any loss or damage suffered through errors or omissions. We will gratefully acknowledge any additions or corrections.



NSK used environmentally friendly paper and printing methods for this publication.

CAT. No. E3162g 2018 A-3 Printed in Japan©NSK Ltd. First edition published in OCT. 2008