

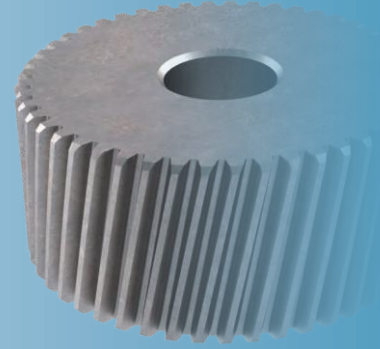

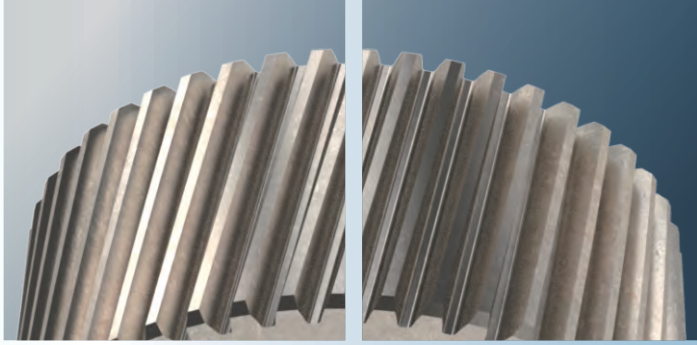







High Precision Planetary Reducers

MODEL	SB	SE	SF	SD	SDD	SBL	SEL	SFL	SDL
Page	12	40	76	58	68	32	52	84	64
Backlash (1-Stage)	1'·3'·5'·7'					2'·4'·6'·8'			
Backlash (2-Stage)	3'·5'·7'·9'					4'·7'·9'·12'			
Ratio (1-Stage)	3·4·5·6·7·8·9·10			4·5·7·10		3·4·5·6·7·8·9·10·12·14·16·18·20			4·5·7·10·14·20
Ratio (2-Stage)	15·20·25·30·35·40·50·60·70·80·90·100			20·25·35·40·50·70·100		15·20·25·30·35·40·50·60·70·80·90·100·120·140·160·180·200			20·25·35·50·40·70·100·140·200
Ratio (3-Stage)	●	●	-	-	-	●	●	-	-
Surface PaintCoat	Coating								
Gear Type	Helical Gear					Helical Gear & Spiral Bevel Gear			
Bearing Type	Ball		Tapper	Ball / Tapper		Ball		Tapper	Ball / Tapper
Fixed Reducer	Bore-Hole	Screw	Bore-Hole			Screw	Bore-Hole		
Gearbox Material	SCM440								
Service Life	>30,000Hr								
Input Bore	5.65mm ~ 75mm		5.65mm ~ 55mm			5.65mm ~ 55mm			
Input Power	100W ~ 75kW		400W ~ 30kW	100W ~ 30kW	-	100W ~ 75kW		400W ~ 30kW	100W ~ 30kW





Precision Planetary Reducers								
SDH	SBT	PB	PBL	PBT	FA	SN	FB	FE
								
74	38	90	98	106	108	124	134	140
-	2'·4'·6'·8'	<8'	<12'	<12'	<8'			
4'·7'·9'·12'	-	<12'	<15'	-	<12'			
-	3·4·5·6·7·8·9·10· 15·20·25·30·35· 40·45·50	同 SB Same as SB	同 SBL Same as SBL	3·4·5·6·7·8·9· 10·15·20·25·30· 35·40·45·50	3·4·5·7·10			
15·25·35 50·70·100 150	-	同 SB Same as SB	同 SBL Same as SBL	-	15·20·25·30·35·40·50·70·100			
-	-	-	-	-	-	-	-	-
Coating		Painting			Black Processing		Painting	
Helical Gear & Hypoid Gear	Helical Gear & Spiral Bevel Gear	Helical Gear	Helical Gear & Spiral Bevel Gear		Helical Gear			
Ball / Tapper	Ball	Ball						
Bore-Hole	Bore-Hole	Bore-Hole			Screw	Bore-Hole	Screw	
SCM440		S45C						
>30,000Hr		>20,000Hr						
5,65mm ~ 55mm	6mm ~ 35mm	5.65mm ~ 55mm	6mm ~ 35mm	6mm ~ 32mm	6mm ~ 24mm	5.65mm ~ 55mm		
100W ~ 30kW	100W ~ 30kW	100W ~ 75kW	100W ~ 5.5kW	100W ~ 3.75kW	100W ~ 1.5kW	100W ~ 30kW		



FB series



■ 1-Stage Backlash ≤ 8 arcmin

■ 2-Stage Backlash ≤ 12 arcmin

Indication of Model Numbers

FB	90	10		MOTOR
Type	Model	Ratio	Output Shaft Keyway	Motor Type
FB FE	50 70 90 120 145 180 220	1-Stage 3, 4, 5, 7, 10 2-Stage 15, 20, 25, 30, 35, 40, 50, 70, 100	<input type="checkbox"/> Standard (Keyway) N: Solid Output Shaft (No Keyway)	

SB
SBL
SBT
SE
SEL
SD
SDL
SDD
SDH
SF
SFL
PB
PBL
PBT
FA
SN
FB
FE



Features of FB Series

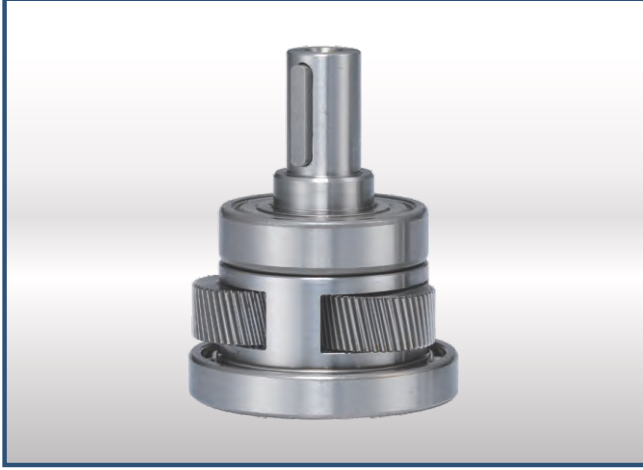

Integrated Planetary Arm Bracket

The planetary arm bracket and the output shaft are one-piece constructed to increase torsional rigidity and accuracy. The entire structure is integrated machined for controlling accuracy in the specified tolerance.

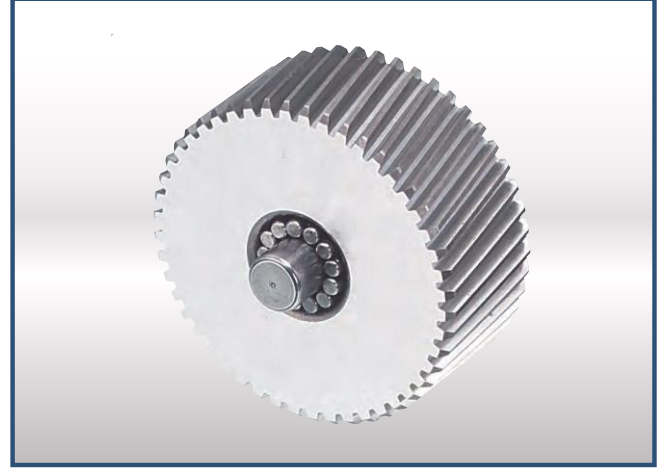

Full Needle Roller Bearings Design

The planetary gear transmission employs full needle roller bearings without retainer to increase the contact surface, which greatly upgrades structural rigidity and service life.

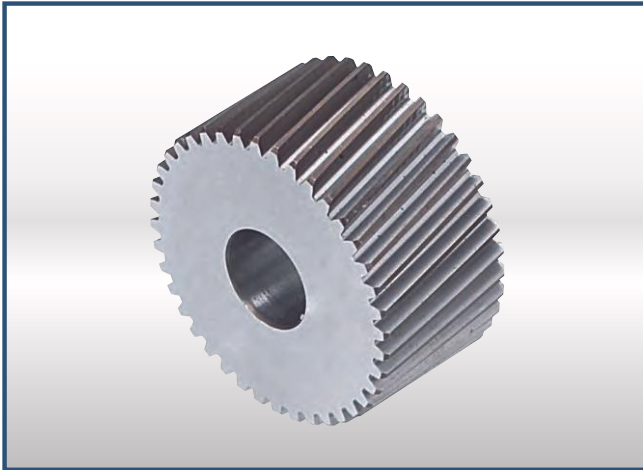

High Precision Gear Machining

The planetary gear and sun gear are manufactured from high quality Ni-Cr-Mo alloy steel (SNM220), precision machined and carburizing heat treatment to hardness 57-60 HRC. Precision teeth grinding or skiving assures gear accuracy reaches DIN6 class.

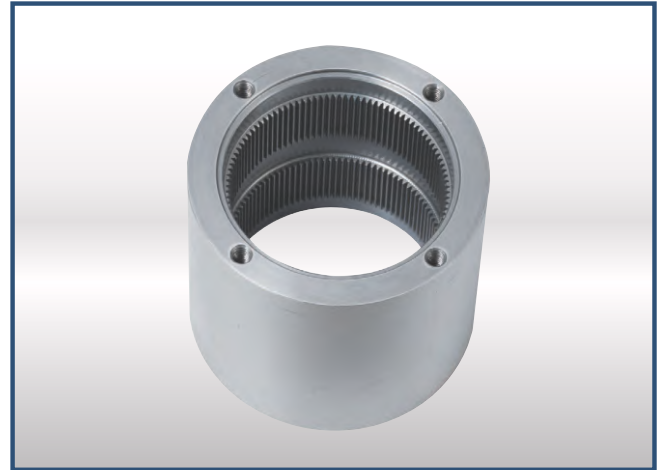

One-piece Gearbox Housing

The gearbox and internal ring gear are one-piece constructed. High gear accuracy meets DIN6 class.



PRECISION PLANETARY REDUCERS

MODEL : FE

RATIO : 3, 4, 5, 7, 10 (1-Stage)

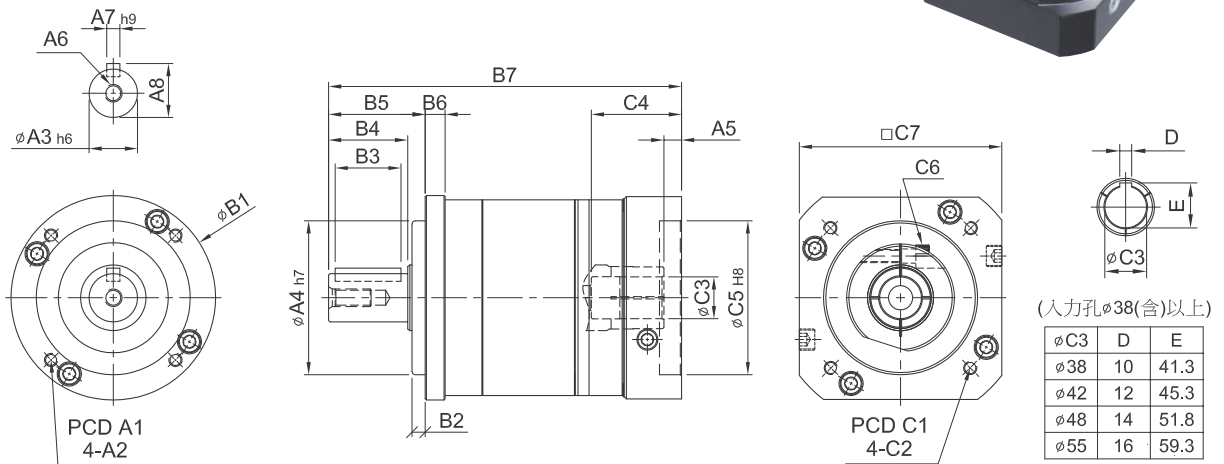

Model Code	50	70	90	120	145	180	220	
A	A1	42	60	80	105	130	184	218
	A2	M4 x P0.7	M5 x P0.8	M6 x P1.0	M8 x P1.25	M10 x P1.5	M12 x P1.75	M16 x P2.0
	A3	13	16	22	32	40	55	75
	A4	35	50	70	90	110	160	180
	A5	5	6	9 · 23.5	10 · 20	10	13 · 15	13.5 · 15.5
	A6	M4 x P0.7	M5 x P0.8	M8 x P1.25	M10 x P1.5	M12 x P1.75	M14 x P2.0	M16 x P2.0
	A7	5	5	6	10	12	16	20
	A8	15	18	24.5	35	43	59	79.5
B	B1	Ø50	Ø70	Ø93	Ø122	Ø148	Ø205	Ø242
	B2	4	5	6	8	10	20	20
	B3	15	20	30	40	65	70	90
	B4	20	28	36	50	74	82	104
	B5	25	34	44	60	87	106	129
	B6	6	8	9	12	15	21.5	30
	B7	100.5	132.5 · 140.5	170.5 · 185	227.5 · 237.5	291	325 · 327	376.5 · 378.5
C	C1	46 · 60 · 63	70 · 75 · 90	90 · 100 · 115 · 145	115 · 145 · 165	145 · 165 · 200	200 · 215 · 265	200 · 265 · 300
	C2	M3 M4 M5	M4 M5 M6	M5 M6 M8	M6 M8 M10	M8 M10 M12	M10 M12	M12 M16
	C3	8 · 9 · 11	14 · 19	19 · 22 · 24	24 · 28 · 32	35 · 38	38 · 42 · 48	42 · 48 · 55
	C4	26	33.5	51 · 65.5	63 · 73	81.5	115 · 117	118 · 120
	C5	30 · 40 · 50	40 · 50 · 60	70 · 80 · 95 · 110	95 · 110 · 130	110 · 130 · 180	114.3 · 180 · 230	114.3 · 230 · 250
	C6	M4 x P0.7	M5 x P0.8	M6 x P1.0	M8 x P1.25	M10 x P1.5	M10 x P1.5	M10 x P1.5
	C7	46 · 55	64 · 70 · 80	92 · 110 · 130	122 · 130 · 150	146 · 150 · 190	182 · 200 · 250	222 · 250 · 265



SB
SBL
SBL SBT
SE
SEL
SD
SDL
SDD
SDH
SF
SFL
PB
PBL
PBT
FA
SN
FB
FE

Characteristic of FE 1-Stage

Model No.		Unit	Ratio	50	70	90	120	145	180	220
Rated Output Torque (Nominal output torque)	T_{2N}	Nm	3	17	50	125	268	482	940	1,420
			4	15	45	111	238	426	860	1,300
			5	14	42	104	223	401	835	1,270
			7	13	39	98	208	373	790	1,180
			10	12	37	92	198	356	760	1,140
Max. Acceleration Torque	T_{2B}	Nm	3~10	1.8 Times of Rated Output Torque						
Max. Output Torque Emergency Stop Torque	T_{2NOT}	Nm	3~10	3 Times of Rated Output Torque						
Rated Input Speed	n_{1N}	rpm	3~10	3,000	3,000	3,000	3,000	3,000	2,000	2,000
Max. Input Speed	n_{1B}	rpm	3~10	5,000	5,000	5,000	5,000	5,000	3,000	3,000
Backlash		arcmin	3~10	≤ 8	≤ 8	≤ 8	≤ 8	≤ 8	≤ 8	≤ 8
Torsional Rigidity		Nm/arcmin	3~10	2.3	5	15	45	69	140	220
Max. Radial Force	F_{2rB}	N	3~10	750	1,180	3,000	6,500	9,100	11,150	35,000
Max. Axial Force	F_{2aB}	N	3~10	325	590	1,500	3,250	4,550	5,575	17,500
Service Life	L_H	hr	3~10	S5 Cycle Operation: >20,000 (S1 Continuous Operation: >10,000 hrs)						
Efficiency	η	%	3~10	≥ 97%						
Operating Temperature		°C	3~10	-25° C ~ +90° C						
Lubrication			3~10	Synthetic Grease						
Protection Class			3~10	IP65						
Mounting Position			3~10	Any						
Noise Level		dB	3~10	≤ 62	≤ 62	≤ 65	≤ 68	≤ 70	≤ 70	≤ 70
Weight ±3%		Kg	3~10	0.63	1.57	3.22	8	16	33	54

Mass Moments of Inertia (kg.cm²)

Ratio	50	70	90	120	145	180	220
3	0.04	0.14	0.61	3.25	8.75	24.63	50.67
4	0.04	0.13	0.48	2.74	7.16	20.12	46.21
5	0.04	0.11	0.47	2.74	6.84	19.80	45.28
7	0.04	0.11	0.44	2.58	6.78	19.21	43.32
10	0.04	0.11	0.44	2.57	6.68	19.13	42.98



Quality First & Customers Satisfaction

Collet Locking Mechanism

Collet Screw & Set Collar Torque Table

MODEL									Spec. of Collet Screw	Screw Grade	Tighten Torque (Nm)	Clench Torque (Nm)	key
SB SE	SBT PBT	SD	SDH	SF	PB	FA	SN	FB					
44	44	47	64	-	44	50	50 60	50	M4 x P 0.7	12.9	4.83	87	
62	62	64	90	62	62	70 80 90	70 80	70	M5 x P 0.8	12.9	10	164	
90	90 120	90	110	75	90	100	115	90	M6 x P 1.0	12.9	16.3	233	
120	142	110	140	100	120	120	-	120	M8 x P 1.25	12.9	41	423	
142	180	140	200	142	142	-	-	145	M10 x P 1.5	12.9	81	678	
180 220	-	200 255	255	180	180 220	-	-	180 220	M10 x P 1.5	12.9	81	678	●
270 330	-	-	-	-	-	-	-	-	M12 x P 1.75	12.9	110	813	●

It will cause slip when motor torque exceeds clench torque.

Input Bore	Ø38	Ø42	Ø48	Ø55	Ø60	Ø75
Key	10 x 8	12 x 8	14 x 9	16 x 10	18 x 11	20 x 12

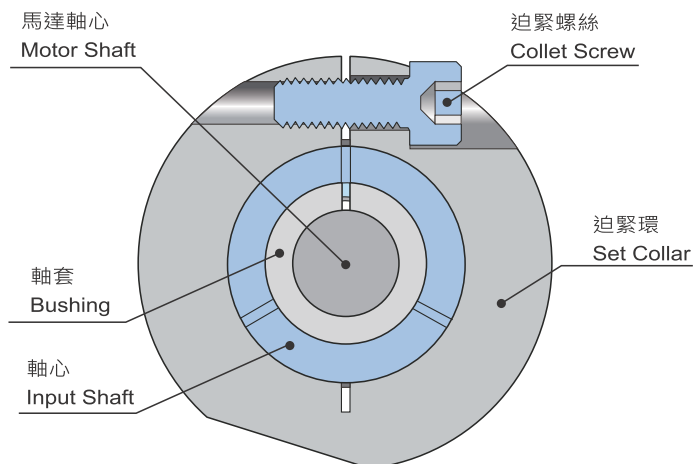



Reference Selection Table of Motor

1-Stage

Model	SB SE PB	44	-	-	62	90	120	142	-	-	180	220	270	330
	SB-A SE-A PB-A	44A	-	-	62A	90A	120A	142A	-	-	180A	220A	-	-
Power	SD	47	-	-	64	90	110	140	-	-	200	255	-	-
	SF	-	-	-	62	75	100	-	142	-	180	-	-	-
	SF-A	-	-	-	62A	75A	100A	-	142A	-	180A	-	-	-
	FA	-	50	-	80	100	120	-	-	-	-	-	-	-
	SN	-	50	60	70 80	115	-	-	-	-	-	-	-	-
	FB- FE	50	-	-	70	90	120	-	145	180	-	220	-	-
	Input Bore	8 9 11	8 10 11 14	8 9 10 12.7 14	14 19	19 22 24	24 28 32	28 32 35	35 38	38 42 48	38 42 48 55	42 48 55	48 55 60 70	55 60 75
100 W	●	●	●											
200 W	●	●	●											
400 W		●	●	●										
750 W				●	●									
1 kW					●									
1.5 kW					●	●								
2.2 kW						●	●							
3.75 kW						●	●	●						
5.5 kW							●	●	●	●				
7.5 kW								●	●	●				
11 kW									●	●	●			
15 kW									●	●	●			
22 kW									●	●	●	●		
30 kW										●	●	●	●	
37 kW													●	
45 kW													●	
55 kW													●	
75 kW													●	

The table is for reference. The selected model shall be based on rated output torque.



Reference Selection Table of Motor

2-Stage

Model	SB SE PB	-	62	-	-	-	90	-	120	-	142	-	180	-	-	-	-	220	270	330
	SBT PBT	44	-	-	-	62	-	90	-	120	-	142	-	-	180	-	-	-	-	-
Model	SDH	-	64	-	-	90	-	-	110	-	140	-	-	200	-	-	-	255	-	-
	SF	-	62	-	-	-	75	-	100	-	142	-	-	-	-	180	-	-	-	-
	FA	-	-	50	-	-	80	-	100	-	120	-	-	-	-	-	-	-	-	-
	SN	-	-	50	60	-	70 80	-	115	-	-	-	-	-	-	-	-	-	-	-
	FB FE	-	50	-	-	-	70	-	90	-	120	-	-	-	-	145	180	-	220	-
Power	Input Bore	8 11	8 9 11	8 10 11 14	8 9 10 12.7 14	14	14 19	19 24	19 22 24	22 24	24 28 32	28 32	28 32 35	28 32 38	35	35 38	38 42 48 55	38 42 48 55	42 48 55	48 55 60 70
100 W		•	•	•	•															
200 W		•	•	•	•															
400 W				•	•	•	•													
750 W							•	•	•											
1 kW									•	•										
1.5 kW								•	•	•	•									
2.2 kW											•	•	•	•						
3.75 kW											•	•	•	•	•	•				
5.5 kW													•	•	•	•	•	•		
7.5 kW														•		•	•	•		
11 kW																	•	•	•	
15 kW																	•	•	•	
22 kW																	•	•	•	•
30 kW																	•	•	•	•

The table is for reference. The selected model shall be based on rated output torque.



Glossary

Gear Ratio (i)

The gear ratio i indicates the factor by which the gearhead transforms the three relevant parameters of motion (speed, torque and mass moment of inertia). The factor is a result of the geometry of the gearing elements (Example: $i = 10$).

$$\begin{array}{l} n_1 = 3000 \text{ rpm} \xrightarrow{\quad : i \quad} n_2 = 300 \text{ rpm} \\ T_1 = 20 \text{ Nm} \xrightarrow{\quad \cdot i \quad} T_2 = 200 \text{ Nm} \\ J_2 = 10 \text{ kgm}^2 \xrightarrow{\quad : i^2 \quad} J_1 = 0.10 \text{ kgm}^2 \end{array}$$

Input Speed (n_1) [rpm]

Input Speed is same as motor speed, if the motor direct connected gearbox.

Output Speed (n_2) [rpm]

The output speed is calculated by the formula related to input speed n_1 and reduction ratio i .

$$n_2 = \frac{n_1}{i}$$

Nominal Input Speed (n_{IN}) [rpm]

Input speed of gearbox shall be less than nominal input speed in the model of continuous operation (S1). Nominal input speed (n_{IN}) is measured at environment temperature 20° C. If the environment temperature is higher or the temperature of gearbox surface exceeds 90° C, please lower input speed (n_1).



Glossary

Max Input Speed (n_{1B}) [rpm]

It is applied to cyclic operation (S5). Max. input speed is measured at environment temperature 20° C. If the environment temperature is higher or the temperature of gearbox surface exceeds 90° C, please lower input speed (n_1).

Speed (n) [rpm]

Two speeds are of relevance when selecting a gearbox: the maximum speed and the nominal speed at the input. The maximum permissible speed n_{1B} must not be exceeded because it serves as the basis at cyclic operation. The nominal speed n_{1N} must not be exceeded at continuous operation. The housing temperature limits the nominal speed, which must not exceed 90° C. The nominal input speed specified in the catalogue applies to an ambient temperature of 20° C. As can be seen in the diagram below, the temperature limit is reached more quickly in the presence of an elevated outside temperature. In other words, the nominal input speed must be reduced if the ambient temperature is high. The values applicable to your gearbox are available from LIMING on request.

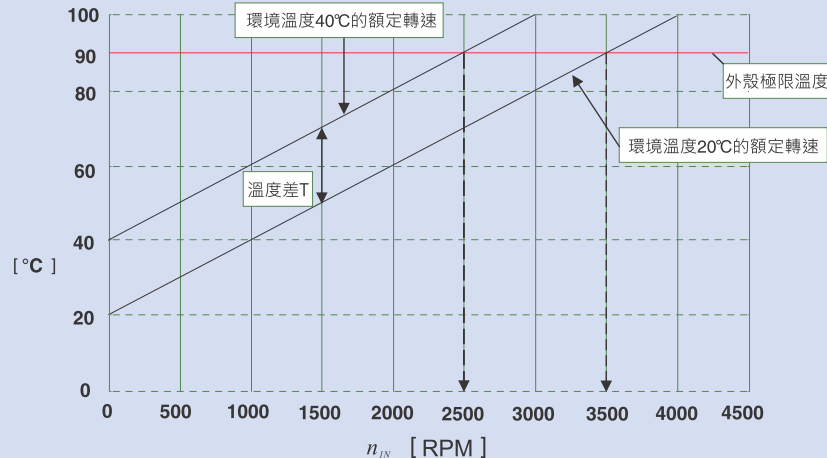

Glossary

Nominal torque (Rated Output Torque) (T_{2N}) [Nm]

The nominal torque T_{2N} is the torque continuously transmitted by a gearbox during a long period of time, i.e. in continuous operation (without wear).

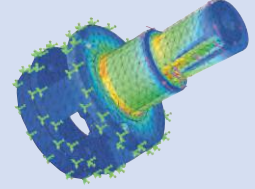

CAE

AE Analysis

Emergency Stop Torque (Max. Output Torque) (T_{2NOT}) [Nm]

The emergency stop torque T_{2NOT} is the maximum permissible torque at the gearbox output end and must not be reached more than 1000 times during the service life of the gearbox. It must never be exceeded to prevent inside parts from damage. LIMING SERVOBOX $T_{2NOT} = 3 \cdot T_{2B}$ (3 times of rated output torque)

Acceleration Torque (T_{2B}) [Nm]

The acceleration torque T_{2B} is the maximum permissible torque that can briefly be transmitted at the gearbox output end under the duty cycle $< 1000/h$ cycles. For $> 1000/h$ cycles, the impact factor must be taken into account. T_{2B} is the max. parameter in cyclic operation. Application acceleration torque (T_{2b}) shall be smaller than T_{2B} ; otherwise the gearbox service life will be reduced.

No Load Running Torque (T_{012}) [Nm]

The no load running torque is the torque which must be applied to a gearbox in order to overcome the internal friction; it is therefore considered lost torque.

Back Driving Torque [Nm]

The back driving torque is the minimum torque to start the rotation from the output side of gearbox. A larger size or a higher ratio gearbox requires greater back driving torque.



Glossary

Average Service Life [h]

Average service life is the working time of gearbox running at rated loading and nominal input speed at cyclic operation.

The service life is not a guarantee of the actual service life of the gear reducer. It is an average calculated life derived from industry formulas (*), and other factors such as running test results, CAE (Computer Aided Engineering) software and so on. These factors take into consideration the metal composition, heat treatment, the design of the gearing and bearings, as well as calculated loads. Service life calculations are not based on actual field conditions or applications, and do not represent a guarantee with respect to expected life, performance, or other characteristics of gear reducer in any given application or use. The actual service life could vary substantially from the nominal service life.

*: Industry formula Refer to the following standardization organization
GB/T 3480-1997 , ISO 6336-1~6336-3:1996

ISO: International Organization for Standardization
GB: Guobiao standards (Chinese National Standards)
DIN: Deutsches Institut für Normung : (German Institute for Standardization)
AGMA: American Gear Manufacturers Association
JIS: Japanese Standards Association

Axial Force (F_{2A}) [N]

The axial force F_{2A} acting on a gearbox runs parallel to its output shaft. The force runs perpendicular to its output shaft. It may be applied with axial offset via a lever arm y_2 under certain circumstances, in which case it also generates a bending moment. If the axial force exceeds the permissible catalogue values, additional design features (e.g. couplings) must be implemented to absorb these forces.



Glossary

Radial Force (F_{2R}) [N]

The radial force is the force acting at right angles to axial force. It acts perpendicular to the axial force and can assume an axial distance of (d) in relation to the shaft end, which acts as a lever arm. The radial force produces a bending moment.

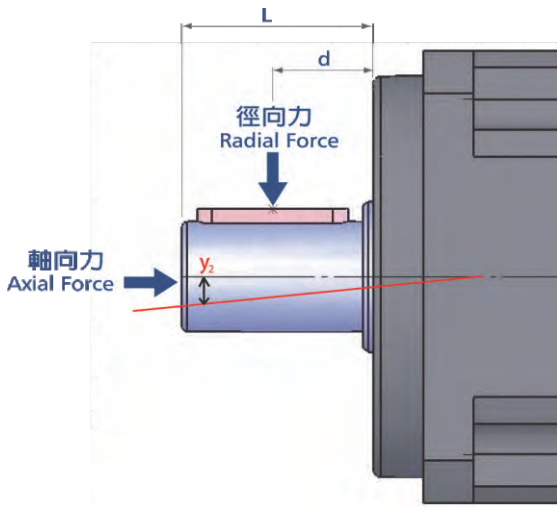

The gearbox will bear radial force while its output shaft connected with transmission machinery, such as chain pulley. The O.H.L. formula of radial force is as below :

$$OHL = \frac{T \cdot s \cdot f \cdot p}{R}$$

T = Torque of transmission machinery

s = Service factor

f = Driven Coefficient

R = Radius of pulley or chain wheel

p = Position Factor: loading position less than d, $p=1$

loading position larger than d, $p=1.5$

(s) Service factor table

Loading classification	Running per Day			
	0.50 hr	2 hr	8-10 hr	10-24 hr
Uniform	0.80	0.90	1.00	1.25
Medium shock	0.90	1.00	1.25	1.50
Heavy shock	1.00	1.25	1.50	1.75

Driven Coefficient (f)

Driving mode	(f)
Chain pulley	1.00
Gear	1.25
V-belt	1.50
Flat-belt	2.50

- CW/CCW operation or start-up/stop reaches 10 times or more within 1 hour, please multiply by 1.2.



Glossary

Permitted Radial Force (F_{2rB}) [N]

The maximum allowed radial force in the 1/2 position of output shaft in the condition of output speed 100 RPM. This value is decreasing when the running speed is increasing.

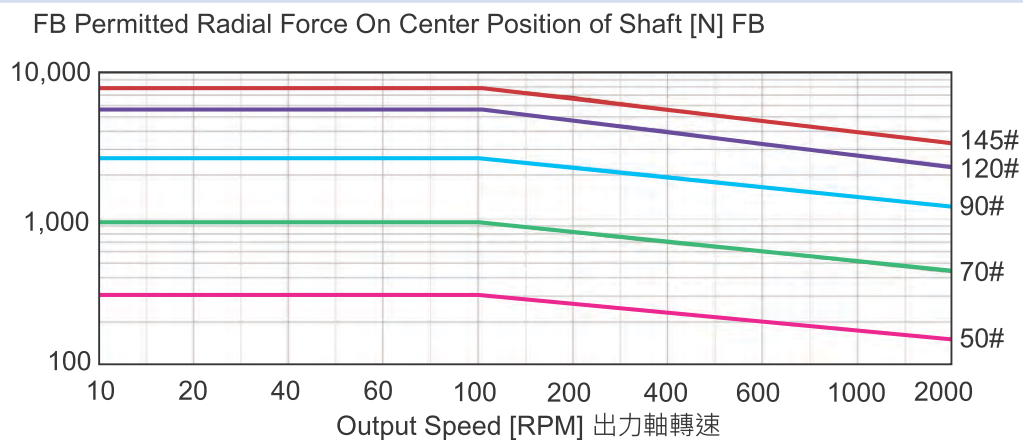

Permitted Axial Force (F_{2aB}) [N]

The maximum allowed axial force in the condition of output speed 100 RPM.

Transmission efficiency η [%]

Efficiency (η) is the ratio of output power to input power. Power lost through friction reduces efficiency to less than 1 or 100%.

$$\eta = \frac{P_{out}}{P_{in}} = \frac{P_{in} - P_{lost}}{P_{in}}$$



Glossary

Noise Level [dB]

The operating noise specified in our catalog relates to gearboxes with the ratio $i=10$ or $i=100$ (2 stage) at input speed 3,000 rpm and no loading running. Noise level is measured at 1M distance from the gearbox. Higher speed results to higher noise level; higher loading results to higher noise level.

Mass moment of inertia (J) [Kg.cm²]

The mass moment of inertia J is a measurement of the effort applied by an object to maintain its momentary condition (at rest or moving).

Rate of mass moment of inertia (λ)

The ratio of mass moment of inertia λ is the ratio of external inertia (application side) to internal inertia (motor and gearbox). It is an important parameter determining the controllability of an application. Accurate control of dynamic processes becomes more difficult with differing mass moments of inertia and as λ becomes greater. LIMING recommends that a guideline value of $\lambda < 5$ is maintained. A gearbox reduces the external mass moment of inertia by a factor of $1 / i^2$.

Simple applications ≤ 10

Dynamic applications ≤ 5

Highly dynamic applications ≤ 1

Torsional Backlash (j_t) [arcmin]

Torsional backlash j_t is the maximum angle of torsion of the output shaft in relation to the input. Torsional backlash is measured with the input shaft locked. The output is then loaded with a defined test torque (2% rated output torque) in order to overcome the internal gearhead friction. The main factor affecting torsional backlash is the face clearance between the gear teeth.

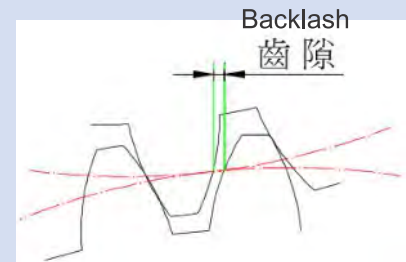

Glossary

Angular minute [Arcmin]

A degree is subdivided into 60 angular minutes (= 60 arcmin = 60'). In other words, if the torsional backlash is specified as 1 arcmin, for example, the output can be turned $1/60^\circ$. The repercussions for the actual application are determined by the arc length.

EX: A pinion with a radius $r = 500$ mm on a gearhead with standard torsional backlash $j_t = 3'$ can be turned $b = 0.44$ mm.

$$b = \frac{2 \cdot \pi \cdot r \cdot j_t}{21600}$$

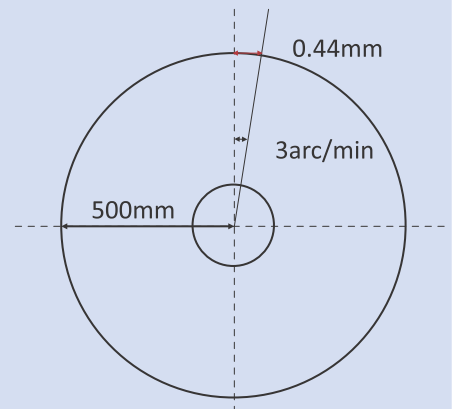

Hysteresis Curve

The hysteresis is measured to determine the torsional rigidity of a gearbox. The result of this measurement is known as the hysteresis curve. If the input shaft is locked, the gearhead is loaded with a torque that increases continuously up to T_{2B} and is then relieved at the output in both directions. The torsional angle is plotted against the torque. This yields a closed curve from which the torsional backlash and torsional rigidity can be calculated.

$$C_{t21} = \frac{\Delta T}{\Delta \phi}$$

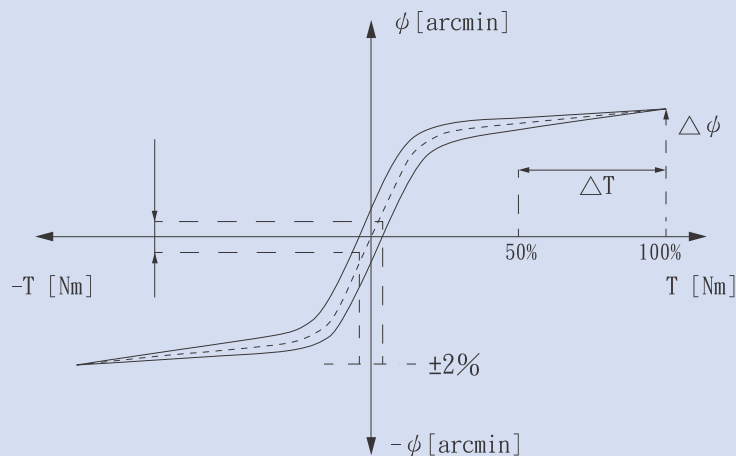

Glossary

Torsional rigidity (C_{t21}) [Nm/Arcmin]

Torsional rigidity is defined as the quotient of applied torque and generated torsion angle.

$$C_{t21} = \frac{\Delta T}{\Delta \phi}$$

It consequently shows the torque required to turn the output shaft by one angular minute. The torsional rigidity can be determined from the hysteresis curve. Only the area between 50% and 100% of T_{2B} is considered because this area of the curve profile can be considered linear.

Operating modes

(continuous operation S1 and cyclic operation S5)

When selecting a gearbox, it is important to consider whether the motion profile is characterized by frequent acceleration and deceleration phases in cyclic operation (S5) as well as pauses, or whether it is designed for continuous operation (S1), i.e. with long phases of constant motion.

Continuous operation (S1)

Continuous operation is defined by the duty cycle. If the duty cycle is greater than 60% or longer than 20 minutes, this qualifies as continuous operation.

Cyclic operation (S5)

Cyclic operation is defined by the duty cycle. If the duty cycle is less than 60% and shorter than 20 minutes, it qualified as cyclic operation.



Glossary

Duty cycle (ED)

The duty cycle ED is determined by one cycle. The times for acceleration (t_a), constant travel if applicable (t_c) and deceleration (t_d) combined yield the duty cycle in minutes. The duty cycle is expressed as a percentage with inclusion of the pause time t_p .

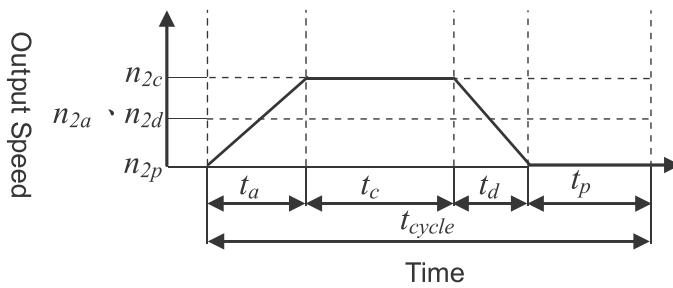

$$ED = \frac{t_a + t_c + t_d}{t_{cycle}}, t_{work} = t_a + t_c + t_d$$

t_a Acceleration , t_c Constant ,

t_d Deceleration , t_p Pause

Stage

The sun gear and planetary gear forms an independent speed reduction gear system. If there is only one gear system in the gear reducer, it is defined as one stage transmission. In order to achieve higher speed reduction ratio, multiple stages transmission is required. LIMING's standard gear reducers are classified into one stage and two-stage transmission. Speed reduction ratio range is from 3 to 100. The modular construction combined with multiple stages transmission allows speed reduction ratio 100~100,000 and over.



Glossary

Degree of protection (IP)

The protective class IP65 sealed design avoids leakage problem.

The various degrees of protection are defined in IEC 60529 "Degrees of protection offered by enclosure (IP code)". The IP degree of protection (IP stands for International Protection) is represented by two digits. The first digit indicates the protection against the ingress of impurities and the second the protection against the ingress of water.

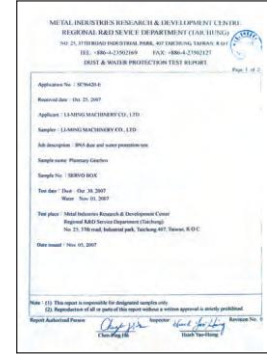

● IP65 Test Report by Metal Industries & Development Center.

Protection against contact and against solid foreign objects.		Protection against ingress of water.	
1st numeral	Description	2nd numeral	Description
0	Non-protected	0	Non-protected
1	Protected against solid foreign objects of >50mm \varnothing	1	Protected against vertically falling water drops
2	Protected against solid foreign objects of >12.5mm \varnothing	2	Protected against vertically falling water drops when enclosure tilted up to 15°
3	Protected against solid foreign objects of >2.5mm \varnothing	3	Protected against spraying water when enclosure tilted up to 60°
4	Protected against solid foreign objects of >1.0mm \varnothing	4	Protected against splashing water
5	Protected against ingress of dust (dust-protected)	5	Protected against water jets
6	Protected against ingress of dust by underpressure (dust-tight)	6	Protected against powerful water jets
		7	Protected against the effects of temporary immersion in water
		8	Protected against the effects of continuous immersion in water



Glossary

Operating Temperature

The Operating Temperature indicates the allowable temperature of gearbox at continuous and cyclic operation. SERVOBOX series work in $-25^{\circ}\text{C} \sim +90^{\circ}\text{C}$.

Consider working temperature, ambient temperature should be in $-25^{\circ}\text{C} \sim +45^{\circ}\text{C}$.

Lubrication

It's no essential to replace lubricant during the service life. Lubrication of standard products uses synthetic grease (0#). It depends on the application, there are other grease available.

Collet Clamping

The Collet Clamping ensure a frictional between motor shaft and gearbox. It has passed dynamical balance analysis to assure concentricity and no backlash at high input speed operation.

Bushing

If the motor shaft diameter is smaller than the input bore of gearbox, a bushing is used to compensate the difference in diameter.



Glossary

Design of connecting plate

Design of connecting plate is suitable for various servo motors or others, and also easy for installation. General dimension is shown on the catalogue. Please find other dimensions from our website.



參數值 Value	單位 Unit
輸出功率 Output Power	0.5 W
額定力矩 Rated Torque	1.39 NM
最大力矩 Max. Torque	4.77 NM
額定轉速 Rated Speed	3000 RPM
最大轉速 Max. Speed	3000 RPM
轉動慣量 Inertia	6.8 kg/cm ²
軸徑 Shaft Dia.	24 mm
外徑 Diameter	130 mm
凸緣	110 mm
PCD	145 mm

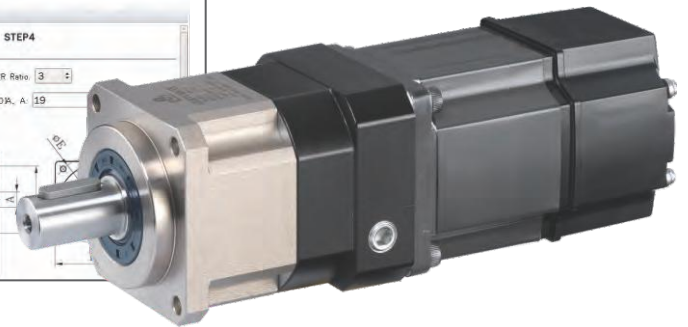

Rotation Directions

1-Stage Planetary Reducer

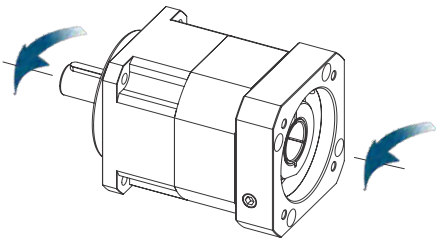

1-Stage Spiral Bevel Gear & Planetary Reducer

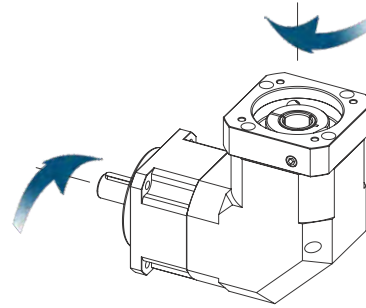

2-Stage Planetary Reducer

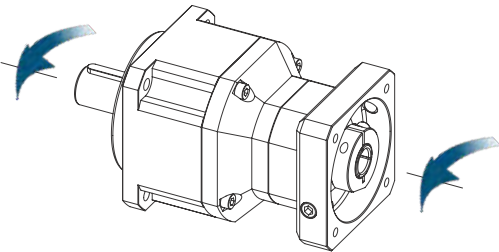

2-Stage Spiral Bevel Gear & Planetary Reducer

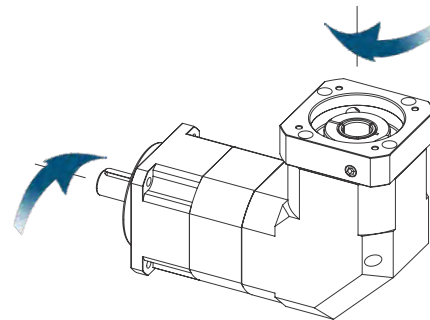

3-Stage Planetary Reducer

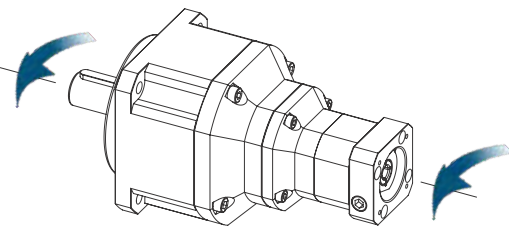

1-Stage Hypoid Gear & Planetary Reducer

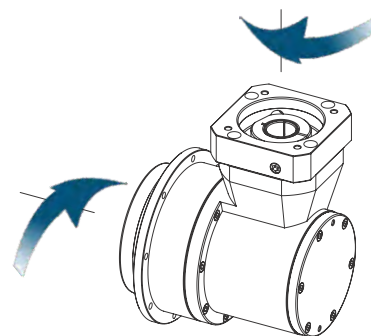

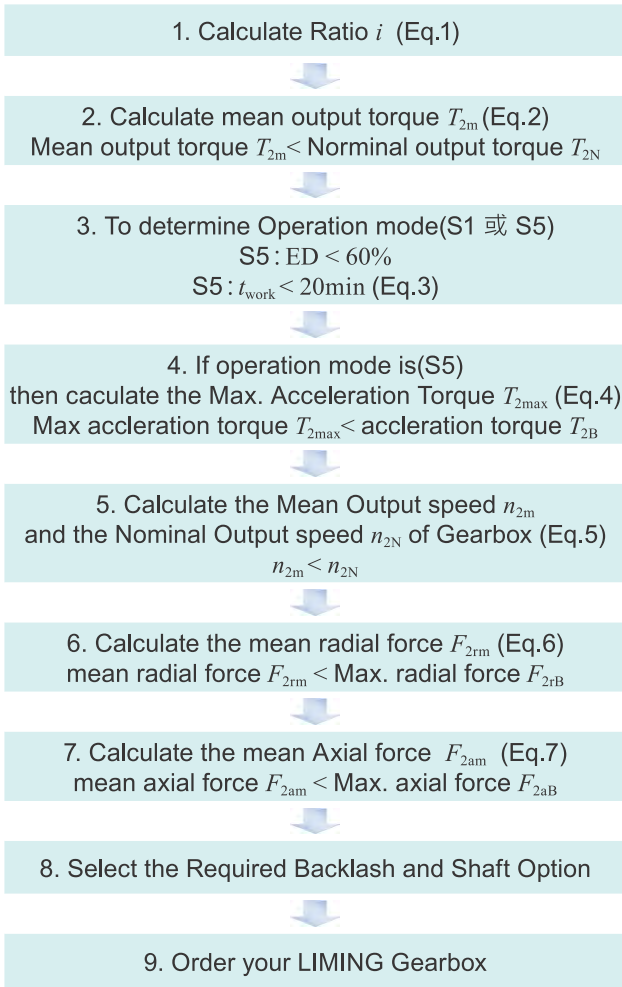

Recommended (for S5 Cyclic Operation)

The general design is given for

$$\frac{J_L}{i^2} \leq 4 \cdot J_m$$

The optimal design is given for

$$\frac{J_L}{i^2} \cong J_m$$

Where J_L is Load Inertia and J_m is Motor Inertia.

T_{2N} please reference catalog 「Rated Output Torque」

F_{2rB} please reference catalog 「Max. Radial Force」

$$\text{Eq.1 } i \cong \frac{n_m}{n_{\text{work}}}$$

n_m is output speed of the motor, n_{work} is working speed

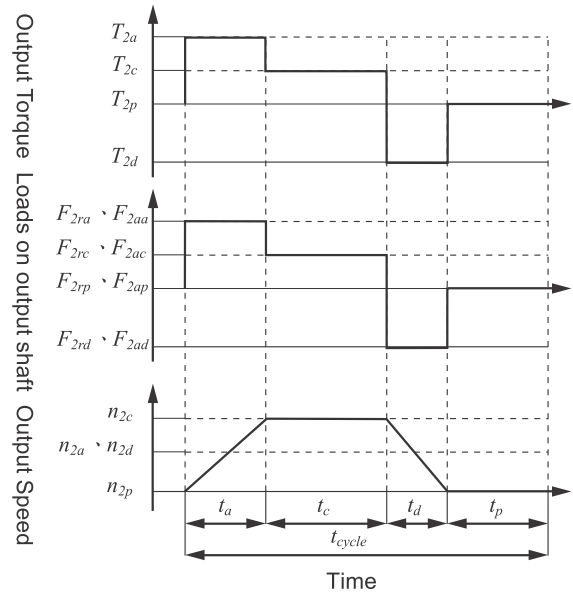

$$\text{Eq.2 } T_{2m} = \sqrt[3]{\frac{n_{2a} \cdot t_a \cdot T_{2a}^3 + n_{2c} \cdot t_c \cdot T_{2c}^3 + n_{2d} \cdot t_d \cdot T_{2d}^3}{n_{2a} \cdot t_a + n_{2c} \cdot t_c + n_{2d} \cdot t_d}}$$

$$\text{Eq.3 } ED = \frac{t_a + t_c + t_d}{t_{\text{cycle}}}, t_{\text{work}} = t_a + t_c + t_d$$

t_a is the time for acceleration, t_c is constant travel,
 t_d is the time for deceleration and t_p is the time for pause.

$$\text{Eq.4 } T_{2\text{max}} = T_{mB} \cdot i \cdot k_s \cdot \eta$$

T_{mB} is the Max. output torque of the motor and η is the efficiency of the gearbox

K_s service factor	
K_s	No. of Cycles / hr
1.0	0 ~ 1,000
1.1	1,000 ~ 1,500
1.3	1,500 ~ 2,000
1.6	2,000 ~ 3,000
1.8	3,000 ~ 5,000

$$\text{Eq.5 } n_{2a} = n_{2d} = \frac{n_{2c}}{2}$$

$$n_{2m} = \frac{n_{2a} \cdot t_a + n_{2c} \cdot t_c + n_{2d} \cdot t_d}{t_a + t_c + t_d}$$

$$n_{2N} = \frac{n_{1N}}{i}$$

$$\text{Eq.6 } F_{2rm} = \sqrt[3]{\frac{n_{2a} \cdot t_a \cdot F_{2ra}^3 + n_{2c} \cdot t_c \cdot F_{2rc}^3 + n_{2d} \cdot t_d \cdot F_{2rd}^3}{n_{2a} \cdot t_a + n_{2c} \cdot t_c + n_{2d} \cdot t_d}}$$

$$\text{Eq.7 } F_{2am} = \sqrt[3]{\frac{n_{2a} \cdot t_a \cdot F_{2aa}^3 + n_{2c} \cdot t_c \cdot F_{2ac}^3 + n_{2d} \cdot t_d \cdot F_{2ad}^3}{n_{2a} \cdot t_a + n_{2c} \cdot t_c + n_{2d} \cdot t_d}}$$



Installation & Critical Applications

Critical applications

For other mounting positions and/or particular input speeds, please contact our technical person.

It is also necessary to take due consideration of and carefully assess the following applications by calling our Technical Service:

- The maximum input speed exceeds nominal input speed.
- The maximum output torque exceeds rated output torque.
- Use in services that could be hazardous for people if the reduction unit fails.
- Applications with especially high inertia.
- Use as a lifting winch.
- Applications with high dynamic strain on the case of the reduction unit.
- Ambient temperature under -25°C or over 45°C .
- Use in chemically aggressive environments.
- Use in a salty environment.
- Use in radioactive environments.
- Use in environments pressures other than atmospheric pressure.

Avoid applications where even partial immersion of the reduction unit is required.

The maximum torque (*) that the gear reducer can support must not exceed three times the nominal torque .

(*) intended for momentary overloads due to starting at full load, braking, shocks or other causes, particularly those that are dynamic.



Installation & Critical Applications

Installation

To install the reduction unit, it is necessary to note the following recommendations:

- The mounting on the machine must be stable to avoid any vibration.
- Check the correct direction of rotation of the reduction unit output shaft before fitting the unit to the machine.
- In the case of particularly lengthy periods of storage (4/6 months), if the oil seal is not immersed in the lubricant inside the unit, it is recommended to change it since the rubber could stick to the shaft or may even have lost the elasticity it needs to function properly.
- Whenever possible, protect the reduction unit against solar radiation and bad weather.
- Ensure the motor cools correctly by assuring good passage of air from the fan side.
- In the case of ambient temperatures $< -25^{\circ} \text{C}$ or $> +45^{\circ} \text{C}$ call the Technical Services.
- The various parts (pulleys, gear wheels, couplings, shafts, etc.) must be mounted on the solid or hollow shafts using special threaded holes or other systems that anyhow ensure correct operation without risking damage to the bearings or external parts of the units. Lubricate the surfaces in contact to avoid seizure or oxidation.
- Starting must take place gradually, without immediately applying the maximum load.
- When there are parts, objects or materials under the motor drive that can be damaged by even limited spillage of oil, special protection should be fitted.



Applications

○ Linear Action

● Ball Screw

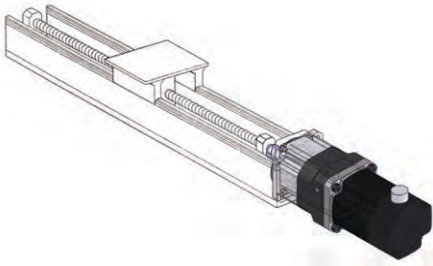

● Rack

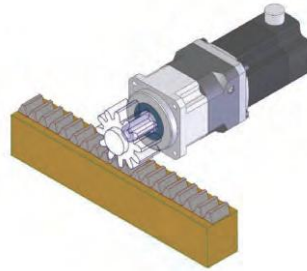

● Roller / Belt

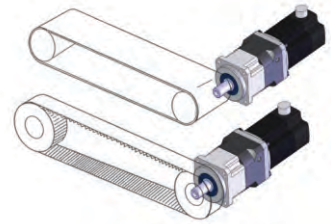

○ Rotary Action

● Index

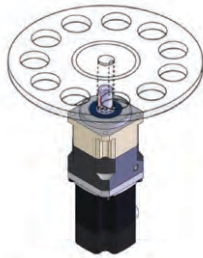

○ Others

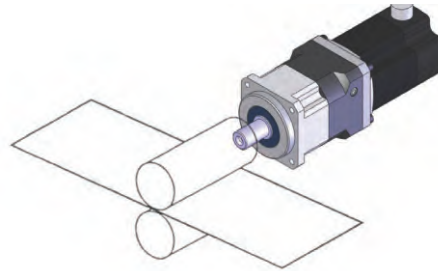

● Robot

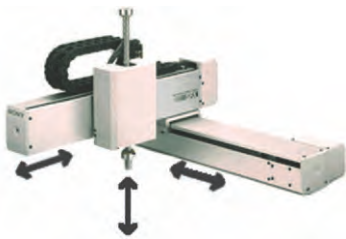

● Printing Machine

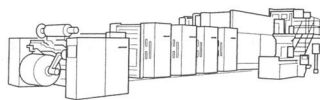

● Conveyor

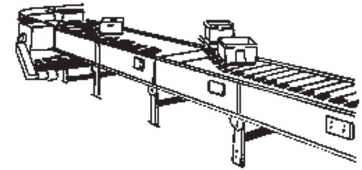

● Working Table

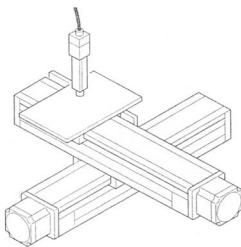

● CNC Spindle

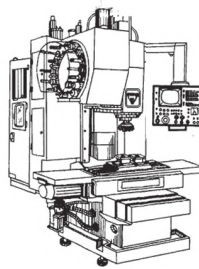

● Index

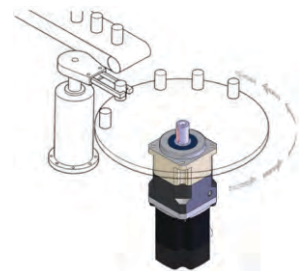

Planetary Gearbox and Motor Mounting Instructions

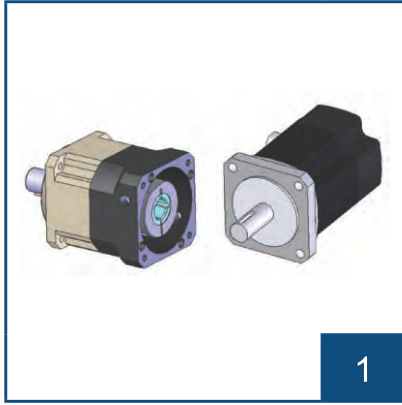

Confirm the motor, and gearbox size.
Clean up the mounting surface.

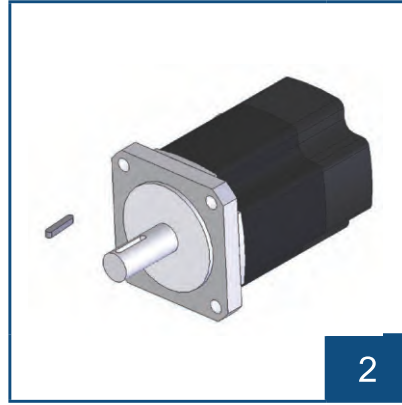

Remove the motor key if the diameter
of motor shaft is under $\varphi 35$.

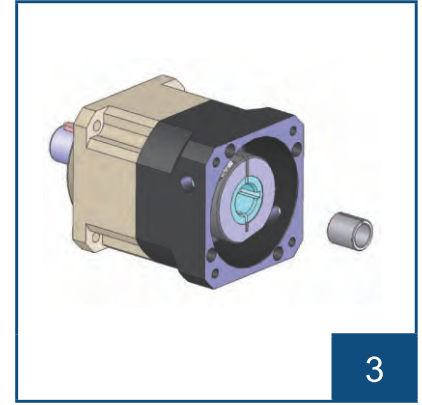

Check motor shaft size and insert
bushing into input bore if necessary.

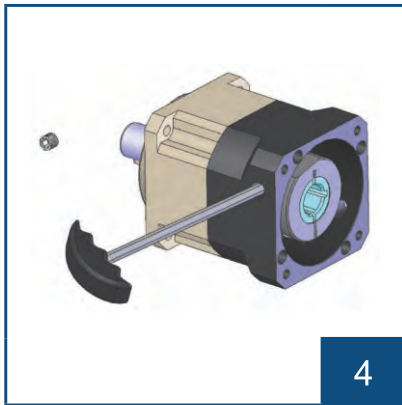

Remove the plug on the adapter plate.
Rotate the set collar till the bolt is line
up.



Put the motor into the gearbox vertically.

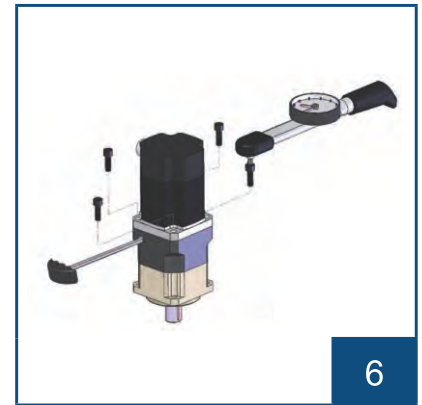

Tighten the mounting bolt in 1~4 order
with torque wrench.

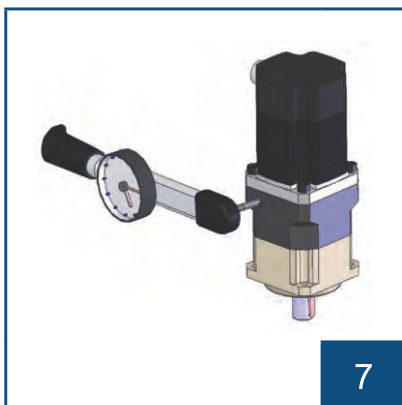

Tighten the set collar bolt with torque
wrench.

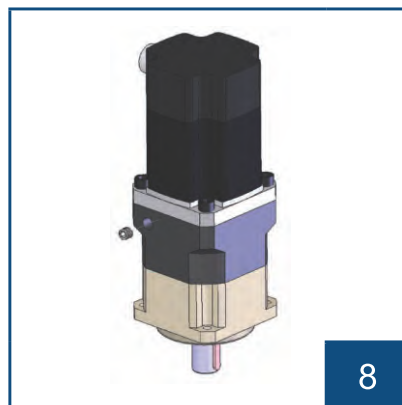

Tighten back the screw plug.

1. To be sure to tighten motor first and
then to tighten the set collar on
motor shaft.

2. Please assembly in order according
to above steps, especially for step 6
and step 7.



Inquiry Information

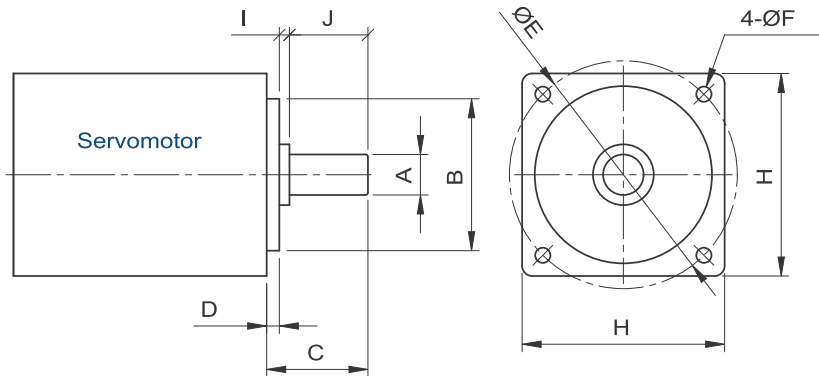

A	B	C	D	E	F	H	I	J

— — — —

Type Model Ratio Output Shaft Keyway Backlash Class MOTOR NO.

General Notices:

- ◆ Type, model and horsepower
- ◆ Speed ratio or R.P.M of output shaft
- ◆ Method of connection and loading
- ◆ Quantity and applied mechanism
- ◆ Input connection method and input speed
- ◆ Motor band Model no or frame & motor shaft dimension

