

VRSF SERIES

VRSF

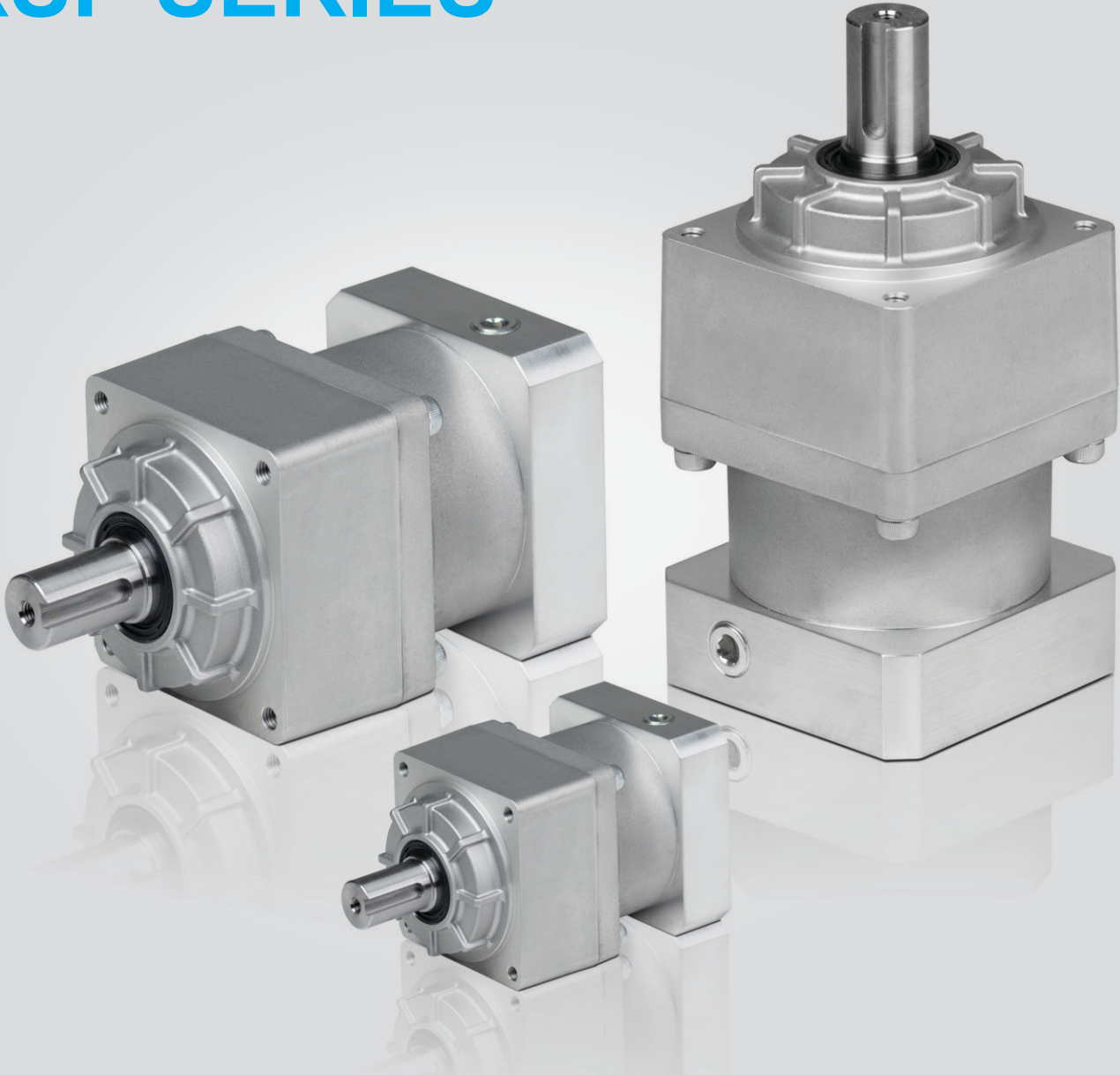

- ▶ Value engineered solution for simple servo and stepper motor applications
- ▶ Quiet operation: Helical cut gears contribute to reduced vibration and noise
- ▶ Wide range of mounting adapters offer a simple, precise attachment to any motor
- ▶ Lightweight aluminum body reduces excess weight
- ▶ Aluminum body, combined with other wash-down features can be used in harsh environments
- ▶ Maintenance-free solution that is lubricated for life. High performance grease allows flexible mounting in any orientation



VRSF B-Frame 1-Stage and 2-Stage Specifications

Frame Size	B								
	1-Stage					2-Stage			
Stage	Units	Note	3	5	9	15	20	25	35
Nominal Output Torque	[Nm]	1	3.43	2.84	2.35	4.02	5.00	6.27	3.84
Maximum Acceleration Torque	[Nm]	2	10.3	8.53	7.25	12.2	15.0	19.0	11.5
Emergency Stop Torque	[Nm]	--	--	--	--	--	--	--	--
Nominal Input Speed	[rpm]	3	3000			3000			
Maximum Input Speed	[rpm]	4	5000			5000			
No Load Running Torque	[Nm]	5	0.119			0.048			
Permitted Radial Load	[N]	6	392	490	588	784	804	882	882
Permitted Axial Load	[N]	7	196	245	294	392	402	441	441
Maximum Radial Load	[N]	8	882N			882N			
Maximum Axial Load	[N]	9	441N			441N			
Moment of Inertia ($\leq \varnothing 8$)	[kgcm ²]	--	0.081	0.059	0.052	0.057	0.056	0.056	0.052
Moment of Inertia ($\leq \varnothing 14$)	[kgcm ²]	--	0.150	0.130	0.120	0.130	0.130	0.130	0.120
Efficiency	[%]	10	90			85			
Torsional Rigidity	[Nm/arcmin]	11	0.8			0.8			
Backlash (Standard)	[Arc-min]	--	≤ 15			≤ 15			
Backlash (Low)	[Arc-min]	--	≤ 10			≤ 10			
Backlash (Precision)	[Arc-min]	--	≤ 3			≤ 3			
Noise Level	[dB]	12	≤ 72			≤ 65			
Protection Class	--	13	IP65			IP65			
Ambient Temperature	[°C]	--	0-40			0-40			
Permitted Housing Temperature	[°C]	--	90			90			
Weight ($\leq \varnothing 8$)	[kg]	14	0.58			0.75			
Weight ($\leq \varnothing 14$)	[kg]	14	0.7			0.86			

1) At nominal input speed, service life is 20,000 hours

2) The maximum torque when starting or stopping operation

3) The average input speed

4) The maximum intermittent input speed

5) Torque at no load applied to the input shaft at nominal input speed

6) At this load and nominal input speed, service life will be 20,000 hours. (The radial load applied to the output side shaft center)

7) At this load and nominal input speed, service life will be 20,000 hours. (The axial load applied to the output side bearing)

8) The maximum radial load that the gearbox can accept

9) The maximum axial load that the gearbox can accept

10) The efficiency at the nominal output torque rating

11) This does not include lost motion

12) Contact Nidec Drive Technology for the testing conditions and environment

13) IP65 (wash-down) is available as an option. Contact Nidec Drive Technology for more details

14) The weight may vary slightly between models

VRSF C-Frame 1-Stage and 2-Stage Specifications

Frame Size	C										
Stage	1-Stage					2-Stage					
Ratio	Units	Note	3	5	9	15	20	25	35	45	81
Nominal Output Torque	[Nm]	1	6.86	11.5	9.7	16.2	21.1	26.4	15.5	9.5	9.7
Maximum Acceleration Torque	[Nm]	2	20.6	34.3	29.2	48.6	63.3	79.2	46.6	28.6	29.2
Emergency Stop Torque	[Nm]	--	--	--	--	--	--	--	--	--	--
Nominal Input Speed	[rpm]	3	3000			3000					
Maximum Input Speed	[rpm]	4	5000			5000					
No Load Running Torque	[Nm]	5	0.29			0.19					
Permitted Radial Load	[N]	6	784	980	1180	1470	1570	1670	1670	1670	1670
Permitted Axial Load	[N]	7	392	490	588	735	785	833	833	833	833
Maximum Radial Load	[N]	8	1670N			1670N					
Maximum Axial Load	[N]	9	833N			833N					
Moment of Inertia ($\leq \emptyset 8$)	[kgcm ²]	--	--	--	--	0.077	0.070	0.062	0.055	0.053	0.052
Moment of Inertia ($\leq \emptyset 14$)	[kgcm ²]	--	0.630	0.380	0.300	0.150	0.140	0.130	0.130	0.120	0.120
--	--	--	1.100	0.880	0.800	--	--	--	--	--	--
Efficiency	[%]	10	90			85					
Torsional Rigidity	[Nm/arcmin]	11	3			3					
Backlash (Standard)	[Arc-min]	--	≤ 15			≤ 15					
Backlash (Low)	[Arc-min]	--	≤ 5			≤ 5					
Backlash (Precision)	[Arc-min]	--	≤ 3			≤ 3					
Noise Level	[dB]	12	≤ 72			≤ 65					
Protection Class	--	13	IP 65			IP65					
Ambient Temperature	[°C]	--	0-40			0-40					
Permitted Housing Temperature	[°C]	--	90			90					
Weight ($\leq \emptyset 8$)	[kg]	14	--			1.8					
Weight ($\leq \emptyset 14$)	[kg]	14	1.8			1.9					
Weight ($\leq \emptyset 19$)	--	14	2.2			--					

- 1) At nominal input speed, service life is 20,000 hours
- 2) The maximum torque when starting or stopping operation
- 3) The average input speed
- 4) The maximum intermittent input speed
- 5) Torque at no load applied to the input shaft at nominal input speed
- 6) At this load and nominal input speed, service life will be 20,000 hours. (The radial load applied to the output side shaft center)
- 7) At this load and nominal input speed, service life will be 20,000 hours. (The axial load applied to the output side bearing)
- 8) The maximum radial load that the gearbox can accept
- 9) The maximum axial load that the gearbox can accept
- 10) The efficiency at the nominal output torque rating
- 11) This does not include lost motion
- 12) Contact Nidec Drive Technology for the testing conditions and environment
- 13) IP65 (wash-down) is available as an option. Contact Nidec Drive Technology for more details
- 14) The weight may vary slightly between models



VRSF D-Frame 1-Stage and 2-Stage Specifications

Frame Size	D										
Stage	1-Stage					2-Stage					
Ratio	Units	Note	3	5	9	15	20	25	35	45	81
Nominal Output Torque	[Nm]	1	18.3	23.5	18.2	30.4	40.6	50.7	37	28.3	17.8
Maximum Acceleration Torque	[Nm]	2	54.9	70.6	54.7	91.2	122	152	111	85.2	53.5
Emergency Stop Torque	[Nm]	--	--	--	--	--	--	--	--	--	--
Nominal Input Speed	[rpm]	3	3000			3000					
Maximum Input Speed	[rpm]	4	5000			5000					
No Load Running Torque	[Nm]	5	0.51			0.26					
Permitted Radial Load	[N]	6	882	1080	1470	1760	1910	2060	2060	2060	2060
Permitted Axial Load	[N]	7	441	539	735	882	955	1030	1030	1030	1030
Maximum Radial Load	[N]	8	2060N			2060N					
Maximum Axial Load	[N]	9	1030N			1030N					
Moment of Inertia ($\leq \varnothing 8$)	[kgcm ²]	--	--	--	--	--	--	--	--	--	0.10
Moment of Inertia ($\leq \varnothing 14$)	[kgcm ²]	--	1.30	0.59	0.38	0.37	0.35	0.34	0.30	0.29	0.29
Moment of Inertia ($\leq \varnothing 19$)	[kgcm ²]	--	1.80	1.10	0.90	0.86	0.84	0.83	0.79	0.78	0.77
Moment of Inertia ($\leq \varnothing 28$)	[kgcm ²]	--	3.60	2.90	2.70	2.70	2.70	2.70	--	--	--
Efficiency	[%]	10	90			85					
Torsional Rigidity	[Nm/arcmin]	11	6			6					
Backlash (Standard)	[Arc-min]	--	≤ 15			≤ 15					
Backlash (Low)	[Arc-min]	--	≤ 5			≤ 5					
Backlash (Precision)	[Arc-min]	--	≤ 3			≤ 3					
Noise Level	[dB]	12	≤ 72			≤ 65					
Protection Class	--	13	IP65			IP65					
Ambient Temperature	[°C]	--	0-40			0-40					
Permitted Housing Temperature	[°C]	--	90			90					
Weight ($\leq \varnothing 8$)	[kg]	14	--			2.8					
Weight ($\leq \varnothing 14$)	[kg]	14	2.8			3.3					
Weight ($\leq \varnothing 19$)	[kg]	14	3.2			3.7					
Weight ($\leq \varnothing 28$)	[kg]	14	4.0			4.8					

- 1) At nominal input speed, service life is 20,000 hours
- 2) The maximum torque when starting or stopping operation
- 3) The average input speed
- 4) The maximum intermittent input speed
- 5) Torque at no load applied to the input shaft at nominal input speed
- 6) At this load and nominal input speed, service life will be 20,000 hours. (The radial load applied to the output side shaft center)
- 7) At this load and nominal input speed, service life will be 20,000 hours. (The axial load applied to the output side bearing)
- 8) The maximum radial load that the gearbox can accept
- 9) The maximum axial load that the gearbox can accept
- 10) The efficiency at the nominal output torque rating
- 11) This does not include lost motion
- 12) Contact Nidec Drive Technology for the testing conditions and environment
- 13) IP65 (wash-down) is available as an option. Contact Nidec Drive Technology for more details
- 14) The weight may vary slightly between models

VRSF E-Frame 1-Stage and 2-Stage Specifications

Frame Size	E										
Stage	1-Stage					2-Stage					
Ratio	Units	Note	3	5	9	15	20	25	35	45	81
Nominal Output Torque	[Nm]	1	44.1	56.8	73.5	91.4	78.4	65.4	71	91.3	43.3
Maximum Acceleration Torque	[Nm]	2	132	171	221	274	235	196	213	274	130
Emergency Stop Torque	[Nm]	--	--	--	--	--	--	--	--	--	--
Nominal Input Speed	[rpm]	3	3000			3000					
Maximum Input Speed	[rpm]	4	5000			5000					
No Load Running Torque	[Nm]	5	1.12			0.62					
Permitted Radial Load	[N]	6	1370	1670	1960	2350	2500	2650	3430	3520	3530
Permitted Axial Load	[N]	7	686	833	980	1180	1250	1320	1715	1760	1765
Maximum Radial Load	[N]	8	3530N			3530N					
Maximum Axial Load	[N]	9	1765N			1765N					
Moment of Inertia ($\leq \emptyset 8$)	[kgcm ²]	--	--	--	0.61	0.63	0.56	0.53	0.40	0.35	0.34
Moment of Inertia ($\leq \emptyset 14$)	[kgcm ²]	--	4.40	1.90	1.20	1.10	1.10	1.00	0.90	0.85	0.84
Moment of Inertia ($\leq \emptyset 19$)	[kgcm ²]	--	6.20	3.70	2.90	3.30	3.20	3.20	2.80	2.70	2.70
Moment of Inertia ($\leq \emptyset 28$)	[kgcm ²]	--	14.00	11.00	11.00	11.00	11.00	11.00	--	--	--
E _{eff} efficiency	[%]	10	90			85					
Torsional Rigidity	[Nm/arcmin]	11	20			20					
Backlash (Standard)	[Arc-min]	--	≤ 15			≤ 15					
Backlash (Low)	[Arc-min]	--	≤ 5			≤ 5					
Backlash (Precision)	[Arc-min]	--	≤ 3			≤ 3					
Noise Level	[dB]	12	≤ 75			≤ 75					
Protection Class	--	13	IP65			IP65					
Ambient Temperature	[°C]	--	0-40			0-40					
Permitted Housing Temperature	[°C]	--	90			90					
Weight ($\leq \emptyset 8$)	[kg]	14	6.1			7.1					
Weight ($\leq \emptyset 14$)	[kg]	14	6.5			7.5					
Weight ($\leq \emptyset 19$)	[kg]	12	7.4			9.3					
Weight ($\leq \emptyset 28$)	[kg]	12	9.8			11.7					

- 1) At nominal input speed, service life is 20,000 hours
- 2) The maximum torque when starting or stopping operation
- 3) The average input speed
- 4) The maximum intermittent input speed
- 5) Torque at no load applied to the input shaft at nominal input speed
- 6) At this load and nominal input speed, service life will be 20,000 hours. (The radial load applied to the output side shaft center)
- 7) At this load and nominal input speed, service life will be 20,000 hours. (The axial load applied to the output side bearing)
- 8) The maximum radial load that the gearbox can accept
- 9) The maximum axial load that the gearbox can accept
- 10) The e_{eff} efficiency at the nominal output torque rating
- 11) This does not include lost motion
- 12) Contact Nidec Drive Technology for the testing conditions and environment
- 13) IP65 (wash-down) is available as an option. Contact Nidec Drive Technology for more details
- 14) The weight may vary slightly between models



VRSF B-Frame 1-Stage and 2-Stage Dimensions

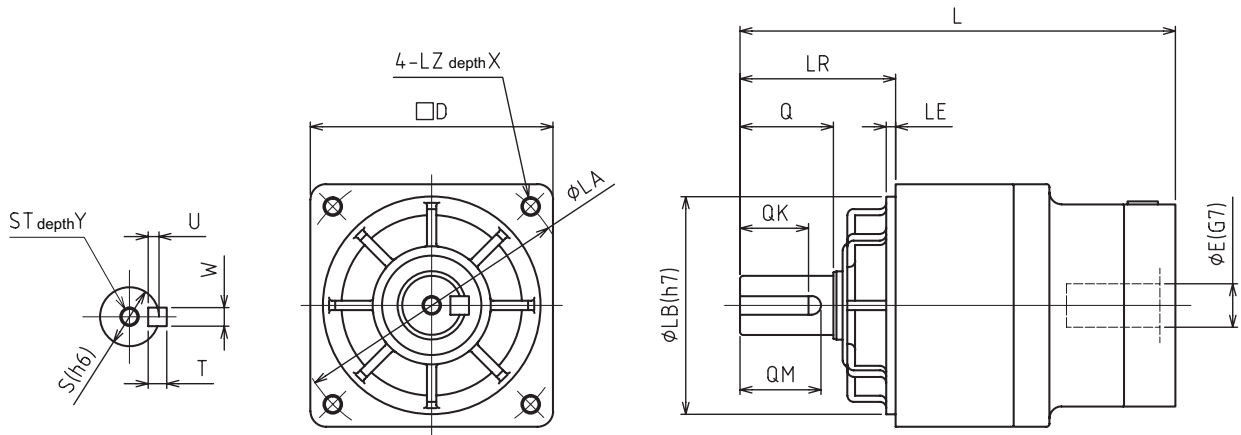

Frame Size	Ratio	Input Bore Dia. E	Dimensions															
			L	LR	S	ST	Y	Q	QM	QK	W×U	T	D	LB	LE	LA	LZ	X
B	1-Stage	≅ φ8	104.5	32	12	M5	10	20	18	16	4×2.5	4	52	50	3	60	M5	12
		≅ φ14	107.5															
	2-Stage	≅ φ8	115.5															
		≅ φ14	118.5															

VRSF C-Frame 1-Stage and 2-Stage Dimensions

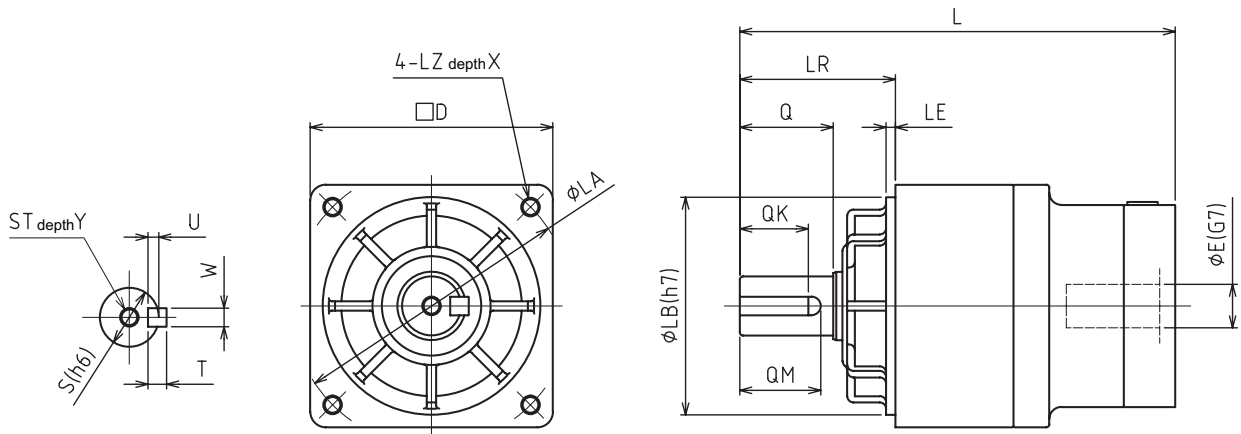

Frame Size	Ratio	Input Bore Dia. E	Dimensions															
			L	LR	S	ST	Y	Q	QM	QK	W×U	T	D	LB	LE	LA	LZ	X
C	1-Stage	≅ φ14	140	50	19	M6	12	30	26	22	6×3.5	6	78	70	3	90	M6	20
		≅ φ19	156															
	2-Stage	≅ φ8	147.5															
		≅ φ14	150.5															

VRSF D-Frame 1-Stage and 2-Stage Dimensions

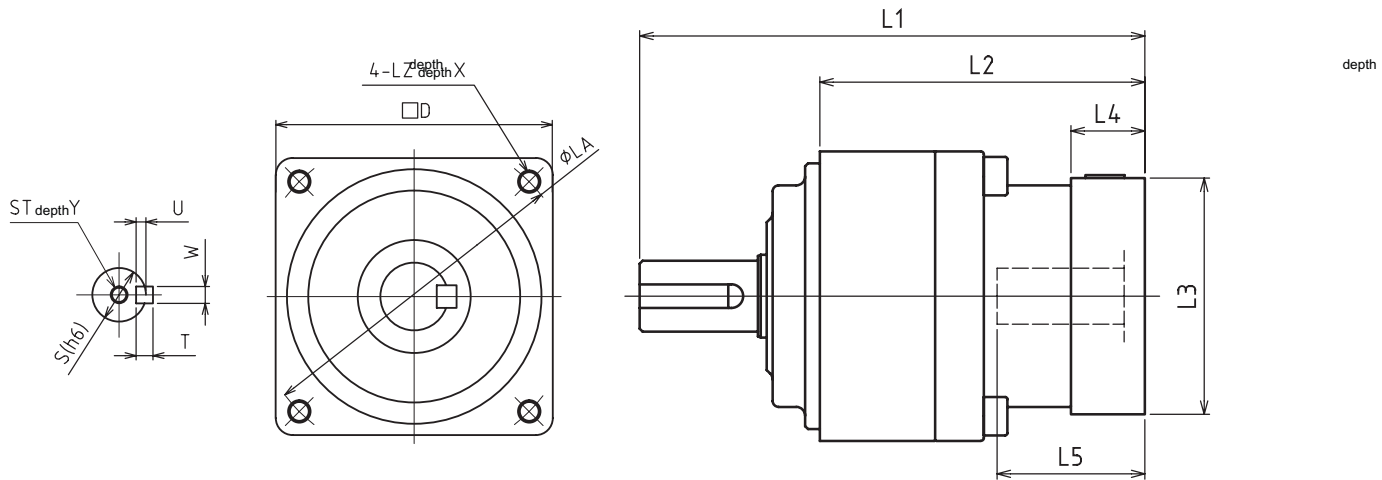

Frame Size	Ratio	Input Bore Dia. E	Dimensions																
			L	LR	S	ST	Y	Q	QM	QK	W×U	T	D	LB	LE	LA	LZ	X	
D	1-Stage	≅ φ14	155	61	24	M8	16	40	35	30	8×4	7	98	90	5	115	M8	20	
		≅ φ19	171																
		≅ φ28	186																
	2-Stage	≅ φ8	163																
		≅ φ14	169																
		≅ φ19	184																
		≅ φ28	200.5																

VRSF E-Frame 1-Stage and 2-Stage Dimensions

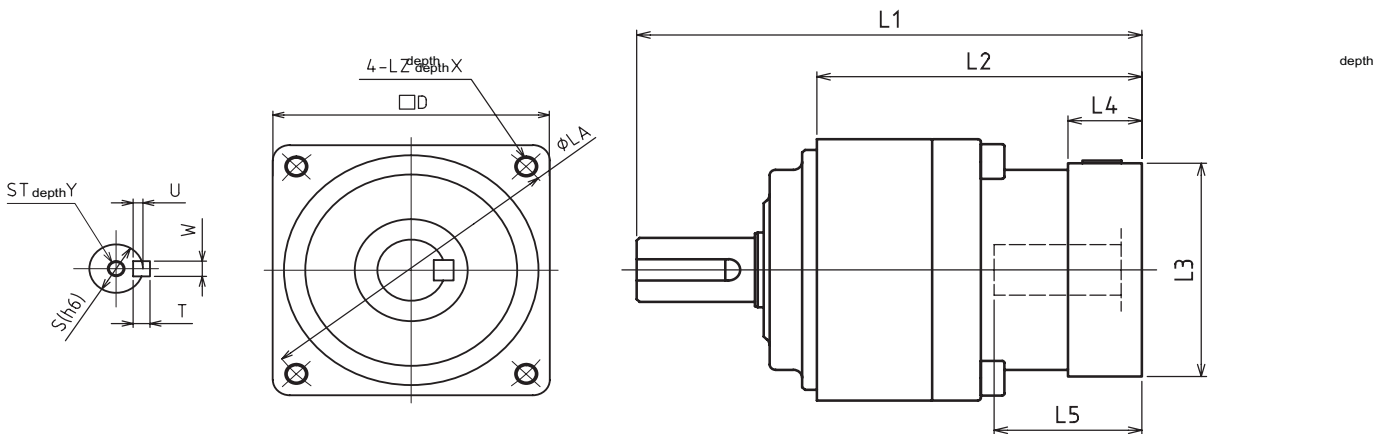

Frame Size	Ratio	Input Bore Dia. E	Dimensions																
			L	LR	S	ST	Y	Q	QM	QK	W×U	T	D	LB	LE	LA	LZ	X	
E	1-Stage	≅ φ14	189	75	32	M10	20	55	52	45	10×5	8	125	110	5	135	M10	20	
		≅ φ19	198.5																
		≅ φ28	224																
	2-Stage	≅ φ38	240																
		≅ φ14	210																
		≅ φ19	225																
		≅ φ28	246.5																
		≅ φ38	261.5																

