

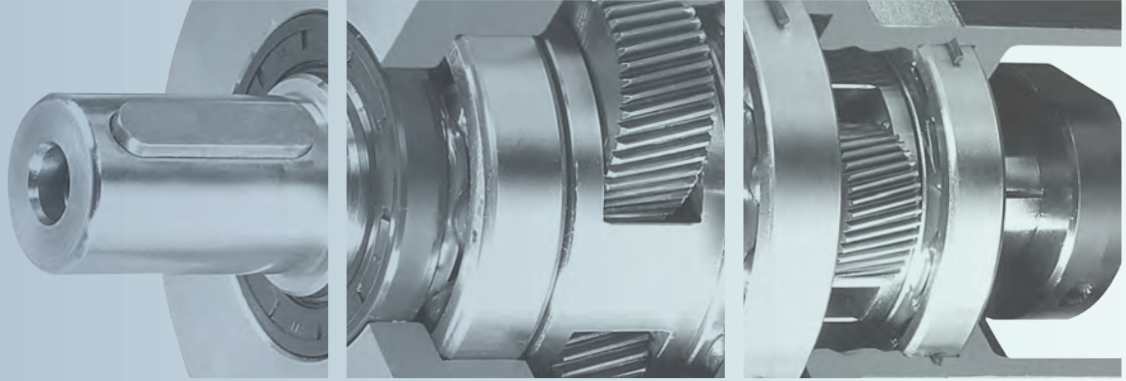

Made in Taiwan



انواع گیربکس های خورشیدی ساخت تایوان









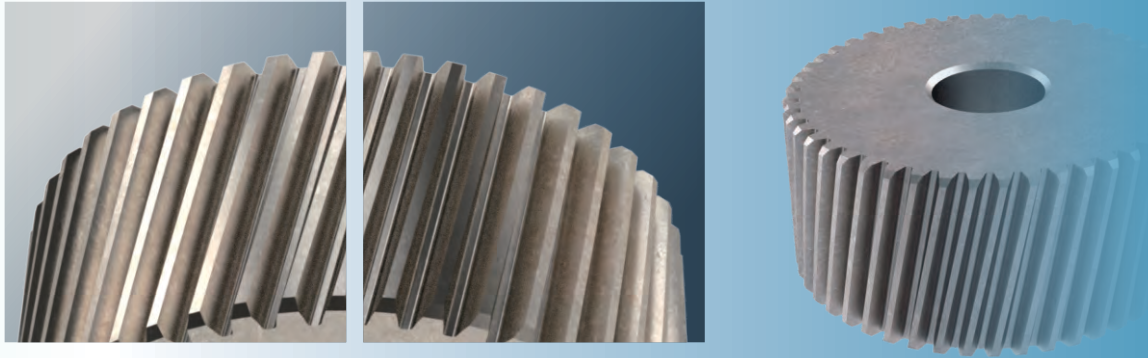

High Precision Planetary Reducers

MODEL	SB	SE	SF	SD	SDD	SBL	SEL	SFL	SDL
Page	12	40	76	58	68	32	52	84	64
Backlash (1-Stage)	1'·3'·5'·7'					2'·4'·6'·8'			
Backlash (2-Stage)	3'·5'·7'·9'					4'·7'·9'·12'			
Ratio (1-Stage)	3·4·5·6·7·8·9·10			4·5·7·10		3·4·5·6·7·8·9·10· 12·14·16·18·20			4·5·7· 10·14·20
Ratio (2-Stage)	15·20·25·30·35·40·50· 60·70·80·90·100			20·25·35·40·50 70·100		15·20·25·30·35·40·50· 60·70·80·90·100·120· 140·160·180·200			20·25·35· 50·40·70· 100·140·200
Ratio (3-Stage)	●	●	-	-	-	●	●	-	-
Surface PaintCoat	Coating								
Gear Type	Helical Gear					Helical Gear & Spiral Bevel Gear			
Bearing Type	Ball	Tapper	Ball / Tapper			Ball	Tapper	Ball / Tapper	
Fixed Reducer	Bore-Hole	Screw	Bore-Hole				Screw	Bore-Hole	
Gearbox Material	SCM440								
Service Life	>30,000Hr								
Input Bore	5.65mm ~ 75mm		5.65mm ~ 55mm			5.65mm ~ 55mm			
Input Power	100W ~ 75kW		400W ~ 30kW	100W ~ 30kW	-	100W ~ 75kW		400W ~ 30kW	100W ~ 30kW





Precision Planetary Reducers

SDH		SBT		PB		PBL		PBT		FA		SN		FB		FE	
																	
74		38		90		98		106		108		124		134		140	
-		2' · 4' · 6' · 8'		<8'		<12'		<12'		<8'		<12'		<12'		<12'	
4' · 7' · 9' · 12'		-		<12'		<15'		-									
-		3 · 4 · 5 · 6 · 7 · 8 · 9 · 10 · 15 · 20 · 25 · 30 · 35 · 40 · 45 · 50		同 SB Same as SB		同 SBL Same as SBL		3 · 4 · 5 · 6 · 7 · 8 · 9 · 10 · 15 · 20 · 25 · 30 · 35 · 40 · 45 · 50		3 · 4 · 5 · 7 · 10		3 · 4 · 5 · 7 · 10		3 · 4 · 5 · 7 · 10		3 · 4 · 5 · 7 · 10	
15 · 25 · 35 50 · 70 · 100 150		-		同 SB Same as SB		同 SBL Same as SBL		-		15 · 20 · 25 · 30 · 35 · 40 · 50 · 70 · 100		15 · 20 · 25 · 30 · 35 · 40 · 50 · 70 · 100		15 · 20 · 25 · 30 · 35 · 40 · 50 · 70 · 100		15 · 20 · 25 · 30 · 35 · 40 · 50 · 70 · 100	
-		-		-		-		-		-		-		-		-	
Coating				Painting				Black Processing				Painting					
Helical Gear & Hypoid Gear		Helical Gear & Spiral Bevel Gear		Helical Gear		Helical Gear & Spiral Bevel Gear		Helical Gear				Helical Gear					
Ball / Tapper		Ball		Ball				Ball				Ball					
Bore-Hole		Bore-Hole		Bore-Hole				Screw		Bore-Hole		Screw		Bore-Hole		Screw	
SCM440				S45C				S45C				S45C					
>30,000Hr				>20,000Hr				>20,000Hr				>20,000Hr					
5,65mm ~ 55mm		6mm ~ 35mm		5,65mm ~ 55mm		6mm ~ 35mm		6mm ~ 32mm		6mm ~ 24mm		5,65mm ~ 55mm		5,65mm ~ 55mm		5,65mm ~ 55mm	
100W ~ 30kW		100W ~ 30kW		100W ~ 75kW		100W ~ 5.5kW		100W ~ 3.75kW		100W ~ 1.5kW		100W ~ 30kW		100W ~ 30kW		100W ~ 30kW	





Quality First & Customer's Satisfaction

LI MING Machinery CO., LTD. is specialist in design, R&D and manufacturing of a wide range of high-tech gear motor and helical gear reducers, worm gear reducers, planetary gear reducers. In recent years, to meet customers' requirements of quality and price, we have been dedicated to constantly upgrade the performance of gear reducer, maximize efficiency, and provide the most comprehensive technical supports. Under the company's policy of " Quality First; Customer Satisfaction and Intelligence; Sincerity; Honesty ", we have invited many highly experienced talents. At LI MING, we have a team with outstanding background in high-tech field. LI MING's outstanding enterprise culture results from its practicality, constantly learning the advanced management system and a commitment to excellence.

The Art of Transmission

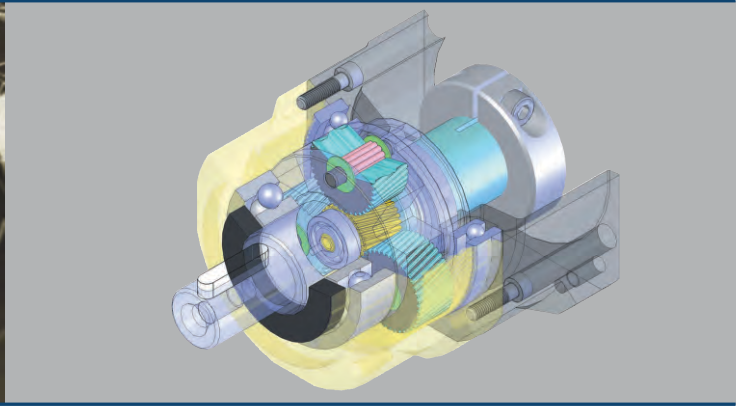

High Accuracy & Efficiency Profit

Among the wide range of speed reducers, the planetary gear reducer features compact construction, high-torque resistance, high transmission efficiency, wide range of speed reduction and high accuracy.

The planetary gear reducers are widely applied in servo, stepping and DC transmission system. With its outstanding feature of high precision transmission, the planetary gear reducer is excellent for reducing speed, increasing torque and reducing torsional inertia ratio. High torque, low backlash and low noise are three key features of LIMING's gear reducers, and these are the reasons why LIMING gear reducers are in the leading position in the industry.



Integration / Automation Machining Equipment

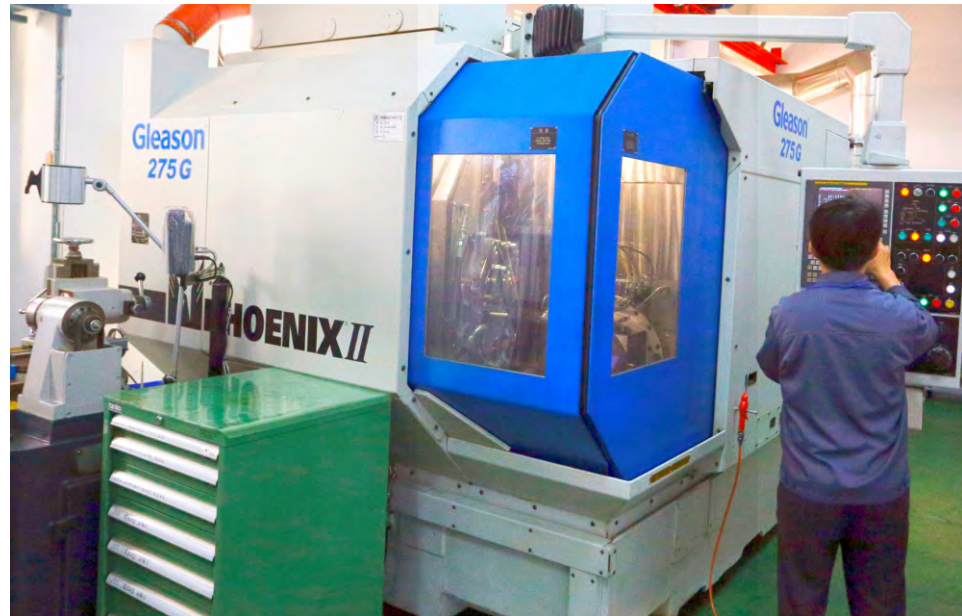

Based on our acknowledgement of the unique processing characteristics of speed reducers on all parts, we have developed and designed a series of high-efficiency automatic machining equipment to work with high-performance processing machines. Our well-experienced technicians take good control of precision in our parts, and stringent quality control to ensure the best precision and performance of all parts and components. A series of automatic processing equipment provides the most solid foundation for the consistency of precision in the machining of parts and components.



Automatic

Processing Equipment



High Precision & Automatic Processing Equipment

To enhance technical improvement, LI MING Machinery Company has placed a huge investment in the purchase of a whole set of the latest generation of Computer Numerically-Controlled (CNC) machines and equipments, in combination with distinguished engineering personnel, to upgrade the precision of parts and ensure stable quality.



Total Quality Management (TQM) isn't a Mere Slogan

Total Quality Management (TQM) is never a mere slogan of LI MING Company. We adhere to our quality policy. To each quality requirement, we have to set up rigorous quality standards for prompt and accurate quality control every single part is subjected to comprehensive inspection and tests, from initial receipt of material to assembly of finished products and regular operation, to completely satisfy your requirement. Our quality control department has the most advanced inspection equipment conducting precision measurement. A good tool is the master of all good works, our precision inspection equipments are the best assurance of our reliable quality.

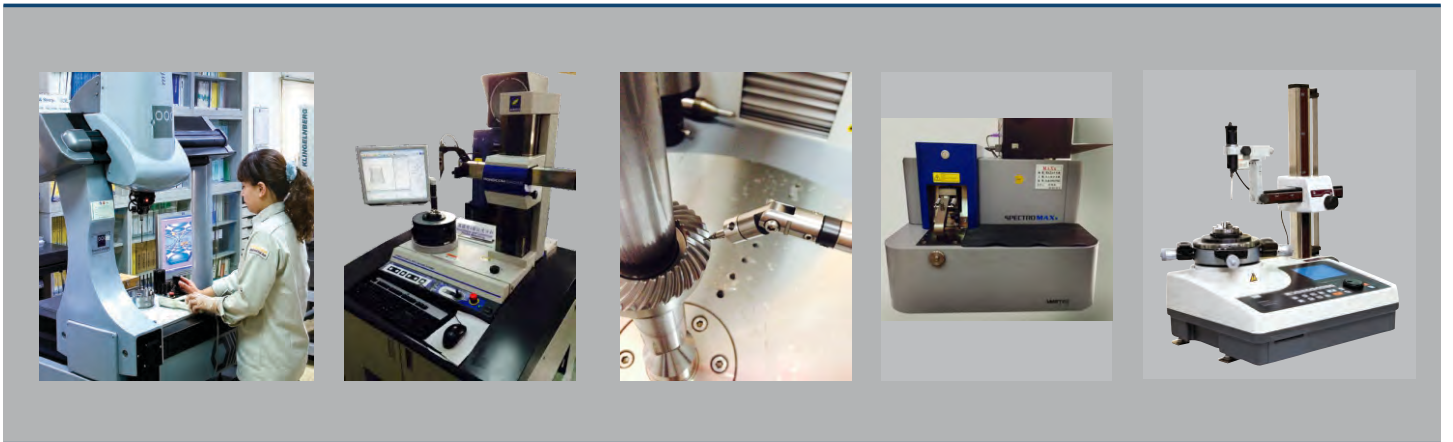
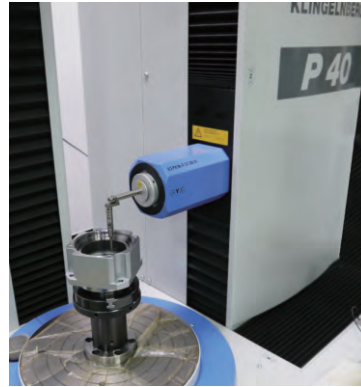
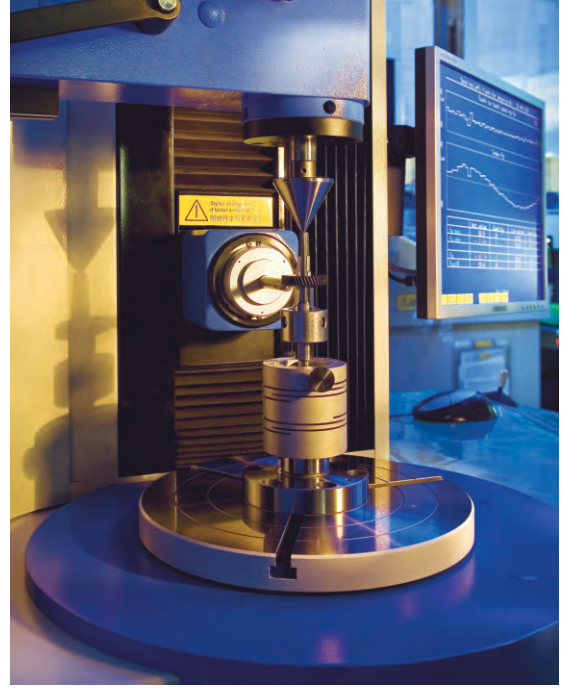

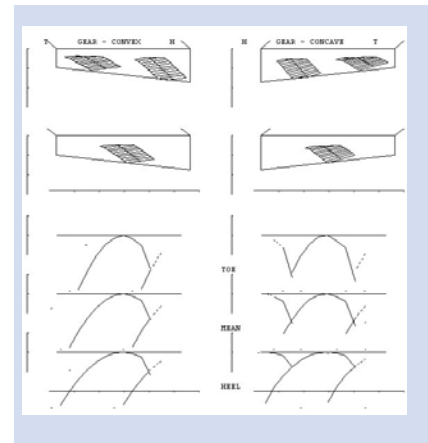
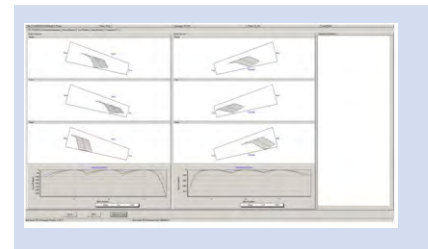
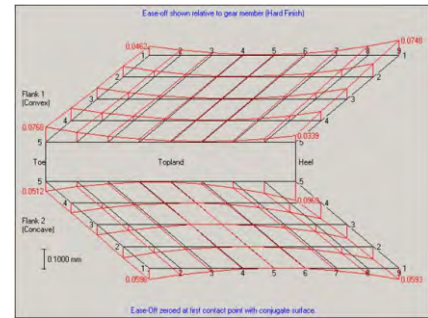

Using high-tech design software and world-class high-precision processing equipment, and with comprehensive quality control. Designed to ensure the quality of the input to the output of the same closed loop production process.



Advanced

Manufacturing Technology



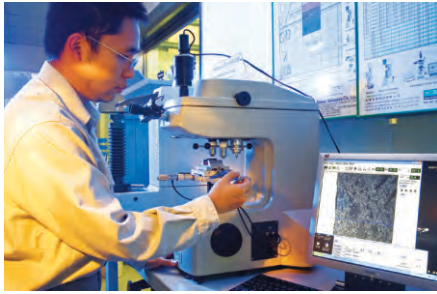

Heat Treatment

Unique vacuum carburization treatment has the features of high surface hardness and interior toughness. It is hard-wearing and hard-tearing. It will keep good engagement under heavy loading.

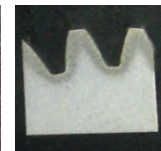
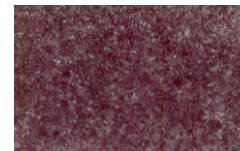
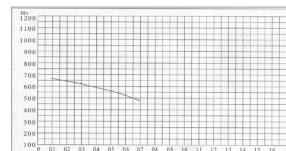

* Hardenability curve

* Metallograph

High Precision

Gear Machining

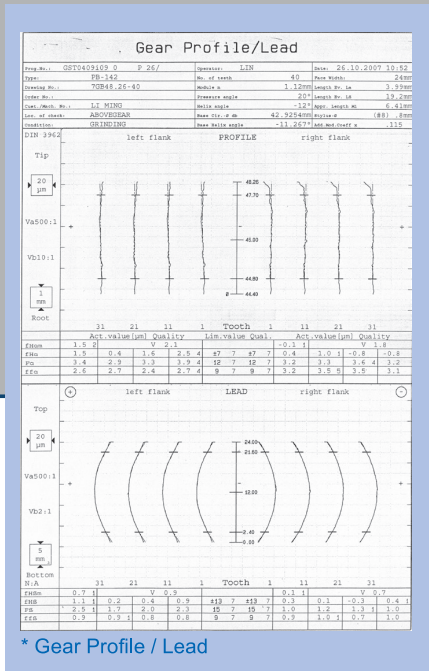

* Gear Profile / Lead

The planetary gear and sun gear are manufactured from high quality NI-Cr-Mo alloy steel (SNM220), precision machined and carburized to hardness 57-60HRC. Precision teeth grinding assures gear accuracy reaches DIN6 class. It provides better wear resistance, impact resistance and longer service life than gears with only surface nitrided.



Features of SERVBOX Series

SERVBOX



SB

SBL

SBT

SE

SEL

SD

SDL

SDD

SDH

SF

SFL

PB

PBL

PBT

FA

SN

FB

FE



Helical Gear Design

The speed reduction mechanism employs helical gears, which provides two times meshing rate of teeth when comparing with regular spur gears. In addition, it also features extremely smooth running, low noise, high torque output and low backlash.



Synthetic Lubrication Grease

The protective class IP65 seals design avoids leakage problem. It features no maintenance.



Collet Locking Mechanism

The input-end and the motor are coupled through a collet locking mechanism. It has passed dynamical balance analysis to assure concentricity and balance on the connection and no backlash for power transmission while running at high speed.



Quality First & Customers Satisfaction



Full Needle Roller Bearings Design

The planetary gear transmission employs full needle roller bearings without retainer to increase the contact surface, which greatly upgrades structural rigidity and service life.



Integrated Planetary Arm Bracket

The planetary arm bracket and the output shaft are one-piece constructed to increase torsional rigidity and accuracy. The entire structure is one-time machined for controlling accuracy in the specified tolerance.

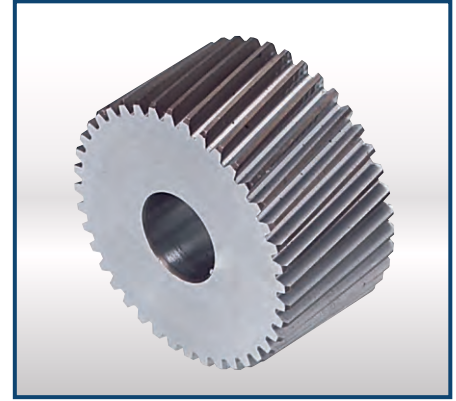

High Precision Gear Machining

The planetary gear and sun gear are made by high quality Ni-Cr-Mo alloy steel (SNCM220), precision machined and carburized to hardness 57-60 HRC. Precision teeth grinding assures gear accuracy reaches DIN6 class. It provides better wear resistance, impact resistance and longer service life than gears with only surface nitrided.

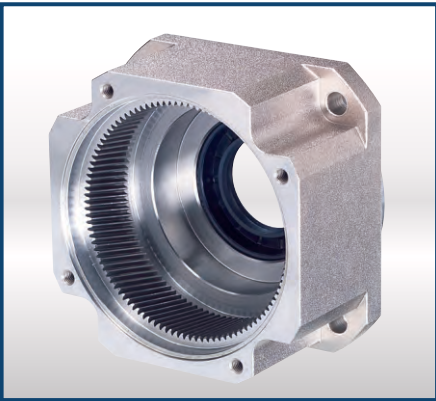

One-piece Gear Box & Advanced Surface Treatment

The gear box and internal gear ring are one-piece constructed, which is made by Cr-Mo alloy steel (SCM440), and tempered for high torque output. High gear accuracy meets DIN6 class standard. Gearbox surface is anti-corrosive treated for upgrading environmental-resistant and corrosion-resistant capability.

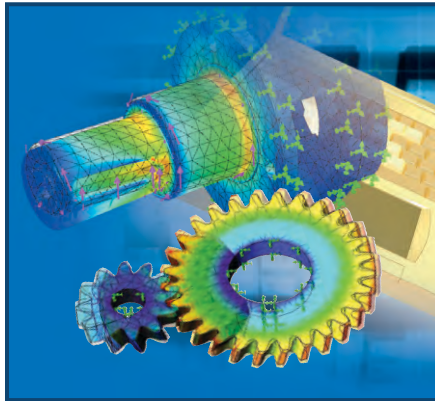

CAE Design and Analysis

Employs 3D-CAE software for analysis and design, the software allows for analyzing the strength of the entire gear reducer and modifying the helical teeth profile and lead. This reduces the impact and noise during teeth engage and disengage, while increasing the service life of gears and the gear reducer.

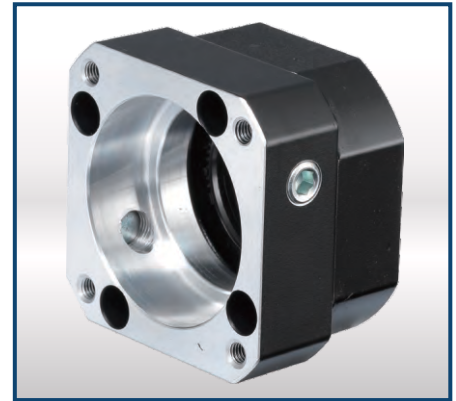

Modular Design of Motor Connection Plate

The special modular design of motor connection plate is suitable for any brand and any type of servomotor. It is made by aluminum alloy. Its surface is anti-oxidant treated for upgrading environmental-resistant and corrosion-resistant capability.





SERVOBOX

Planetary Reducers

SERVOBOX series high precision planetary gear reducer employs helical gears. All gears are high precision machined by CNC gear hobbing machine, providing high accuracy gear engagement, smooth running and minimum noise.

LIMING gear box is one-piece fabricated. When comparing with the competitive gear reducer, LIMING gear reducer features smaller construction (saves over 1/4 of size and weight), higher output torque and higher transmission efficiency.

Characteristic of SERVOBOX Series

SERVOBOX

Low Noise
Under 65dB.

Low Backlash
Backlash for 1-stage model is under 7 arcmin. Available to select specification with 1 arcmin of backlash. Backlash for 2-stage model is under 9 arcmin.

High Efficiency
Efficiency for 1-stage model exceeds 97%; 2-stage model exceeds 94%.

High Input Speed
Input speed allows for 5,000 RPM.

High Torque
Higher output torque is in comparison with spur gear planetary gear reducers.

High Stability
Employs high tensile strength alloy steel. Gear hardening is made for the entire gear instead of only surface hardening, which extends gear service life and maintain high accuracy after a long period of operation.

High Speed Reduction Ratio
The gear reducer is a modular design. The planetary gear box can be connected. Speed reduction ratio can reach over than 1/10000.

SB

SBL

SBL

SE

SEL

SD

SDL

SDD

SDH

SF

SFL

PB

PBL

PBT

FA

SN

FB

FE



Quality First & Customers Satisfaction

Indication of Model Numbers

SB	90	10		P1	MOTOR
Type	Model	Ratio	Output Bearing	Backlash Class	Motor Type
SB	44	1-Stage	Standard (Keyway)	Ps	Motor Brand & Model No.
SE	62	3, 4, 5, 6, 7, 8, 9, 10		P0	
SB-A	90			P1	
SE-A	120	2-Stage	Solid Output Shaft (No Keyway)	P2	
SBL	142	15 ~ 100			
SEL	180	3-Stage			
	220	125 ~ 1000			
	270				
	330				

Description of Standard and A-Type

The features of 2-stage or 3-stage gearbox are high gear ratio and large output torque. The standard type of 2-stage or 3-stage gearbox are combined by big and small gearboxes to have a limit to input power and then to meet rated output torque. A-Type has a combination of 2 gearboxes with same frame.

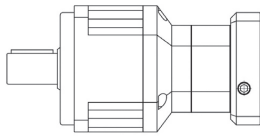

Standard

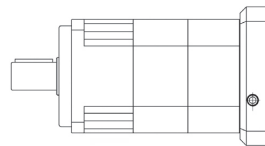

A-Type

Example:

Servo motor 0.5 kW, rated output torque 2.39 Nm,
motor shaft Ø24 mm.

1. Suppose the speed reduction ratio is 1/50:

Output torque is $2.39 \text{ Nm} \times 50 \times 94\%$ (efficiency) = 112 Nm.

- You can select SB-120-50 with rated output torque of 294 Nm and S.F. = 2.6
- You can select SB-90A-50 with rated output torque of 141 Nm and S.F. = 1.25

2. Suppose the speed reduction ratio is 1/100:

Output torque is $2.39 \times 100 \times 94\%$ (efficiency) = 224 Nm.

You can select SB-120-100 and S.F. = 1.3. You are not suggested to choose SB-90A-100 because of low S.F. = 0.62.



SERVOBOX Planetary Reducers

MODEL : SB

1-Stage

RATIO : 3, 4, 5, 6, 7, 8, 9, 10

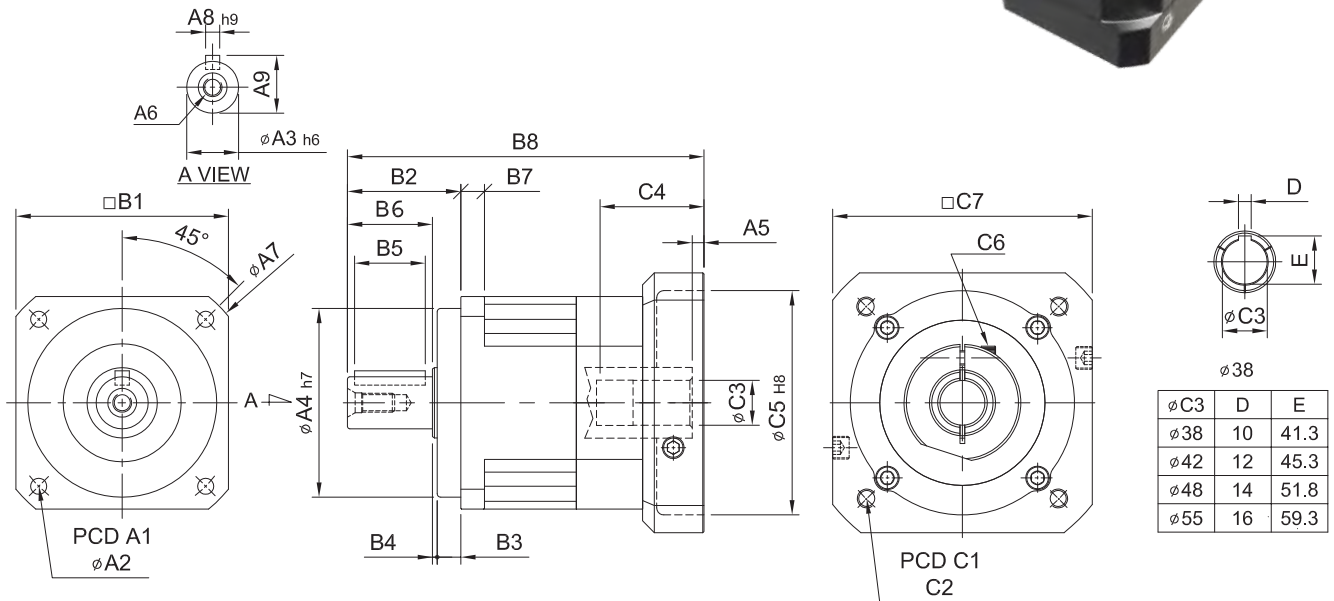

unit: mm

Model Code	44	62	90	120	142	180	220
A1	50	70	100	130	165	215	250
A2	4.5	5.5	6.8	9	11	13	17
A3	13	16	22	32	40	55	75
A4	35	50	80	110	130	160	180
A5	5	6	9 · 23.5	10 · 20	10	11.5 · 14.5	12.5 · 14.5
A6	M4 x P0.7	M5 x P0.8	M8 x P1.25	M10 x P1.5	M12 x P1.75	M14 x P2.0	M16 x P2.0
A7	58	80	116	148	186	238	288
A8	5	5	6	10	12	16	20
A9	15	18	24.5	35	43	59	79.5
B1	44	62	90	120	142	180	220
B2	26	36	48	65	92	106	139
B3	5	7	10	12	15	20	30
B4	1	1	2	3	3	4	5
B5	15	20	30	40	65	70	90
B6	20	28	36	50	74	82	104
B7	5	8	10	12	15	16	20
B8	95	115 · 123	164.5 · 179	205 · 215	260.5	323.5 · 326.5	367.5
C1	46 · 60 · 63	70 · 75 · 90	90 · 100 · 115 · 145	115 · 145 · 165	145 · 165 · 200	200 · 215 · 265 · 300	200 · 265 · 300
C2	M3 · M4 · M5	M4 · M5 · M6	M5 · M6 · M8	M6 · M8 · M10	M8 · M10 · M12	M10 · M12 · M16	M12 · M16
C3	8 · 9 · 11	14 · 19	19 · 22 · 24	24 · 28 · 32	32 · 35 · 38	38 · 42 · 48 · 55	42 · 48 · 55
C4	26	33.5 · 41.5	59 · 73.5	67 · 77	84.5	114.5 · 117.5	117.5 · 119.5
C5	30 · 40 · 50	50 · 60 · 70	70 · 80 · 95 · 110	95 · 110 · 130	110 · 130 · 180	114.3 · 180 · 230 · 250	114.3 · 230 · 250
C6	M4 x P0.7	M5 x P0.8	M6 x P1.0	M8 x P1.25	M10 x P1.5	M10 x P1.5	M10 x P1.5
C7	46 · 55	64 · 70 · 80	92 · 110 · 130	122 · 130 · 150	146 · 150 · 190	182 · 200 · 250 · 265	222 · 250 · 265



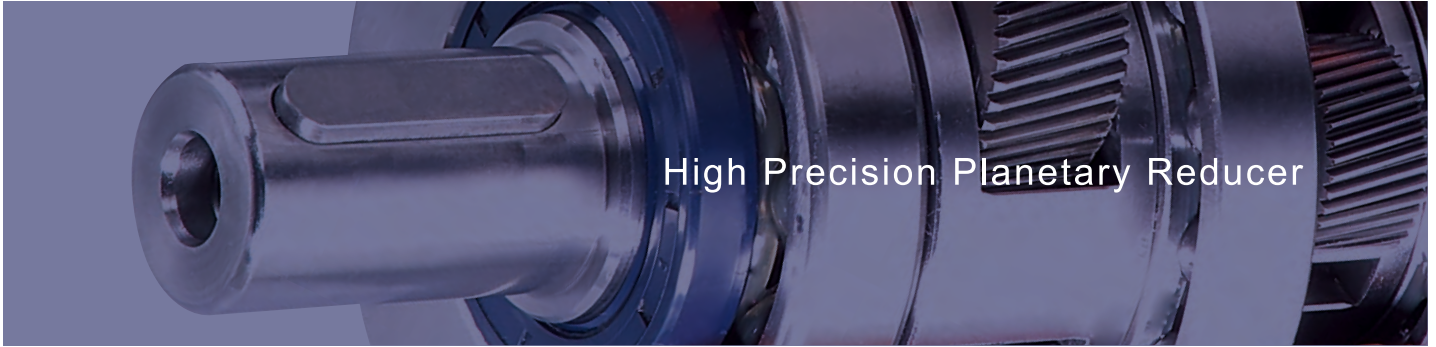

Model No.		Unit	Ratio	44	62	90	120	142	180	220
Rated Output Torque (Nominal output torque)	T_{2N}	Nm	3	19	59	165	335	625	1,206	2,030
			4	16	51	146	300	555	1,069	1,804
			5	16	48	160	333	618	1,189	2,010
			6	15	45	151	311	583	1,118	1,911
			7	15	45	149	309	573	1,108	1,870
			8	14	43	143	298	553	1,070	1,824
			9	13	44	145	278	516	993	1,694
			10	14	43	141	294	549	1,059	1,779
Max. Acceleration Torque	T_{2B}	Nm	3 ~ 10	1.8 Times of Rated Output Torque						
Max. Output Torque Emergency Stop Torque	T_{2NOT}	Nm	3 ~ 10	3 Times of Rated Output Torque						
Rated Input Speed	n_{1N}	rpm	3 ~ 10	3,000	3,000	3,000	3,000	3,000	3,000	2,000
Max. Input Speed	n_{1B}	rpm	3 ~ 10	6,000	6,000	6,000	5,000	5,000	4,000	3,000
Backlash Ps		arcmin	3 ~ 10	-	-	≤ 1	≤ 1	≤ 1	≤ 1	≤ 1
Backlash P0		arcmin	3 ~ 10	≤ 3	≤ 3	≤ 3	≤ 3	≤ 3	≤ 3	≤ 3
Backlash P1		arcmin	3 ~ 10	≤ 5	≤ 5	≤ 5	≤ 5	≤ 5	≤ 5	≤ 5
Backlash P2		arcmin	3 ~ 10	≤ 7	≤ 7	≤ 7	≤ 7	≤ 7	≤ 7	≤ 7
Torsional Rigidity		Nm/arcmin	3 ~ 10	3	6	14	27	60	140	240
Max. Radial Force	F_{2rB}	N	3 ~ 10	380	1,180	3,200	6,800	9,300	15,600	51,000
Max. Axial Force	F_{2aB}	N	3 ~ 10	190	590	1,600	3,400	4,650	7,800	25,500
Service Life	L_H	hr	3 ~ 10	S5 Cycle Operation: >30,000 (S1 Continuous Operation: >15,000 hrs)						
Efficiency	η	%	3 ~ 10	≥ 97						
Operating Temperature		$^{\circ}\text{C}$	3 ~ 10	$-25^{\circ}\text{C} \sim +90^{\circ}\text{C}$						
Lubrication			3 ~ 10	Synthetic Grease						
Protection Class			3 ~ 10	IP65						
Mounting Position			3 ~ 10	Any						
Noise Level		dB	3 ~ 10	≤ 56	≤ 58	≤ 60	≤ 63	≤ 65	≤ 67	≤ 70
Weight $\pm 3\%$		Kg	3 ~ 10	0.6	1.28	3.6	8	14.3	28.3	42.5

■ Mass Moments of Inertia (kg.cm²)

Ratio	44	62	90	120	142	180	220
3	0.03	0.16	0.61	3.25	9.21	28.98	59.61
4	0.03	0.14	0.48	2.74	7.54	23.67	54.37
5	0.03	0.13	0.47	2.71	7.42	23.29	53.27
6	0.03	0.13	0.45	2.65	7.25	22.75	51.72
7	0.03	0.13	0.45	2.62	7.14	22.48	50.97
8	0.03	0.13	0.44	2.58	7.07	22.59	50.84
9	0.03	0.13	0.44	2.57	7.04	22.53	50.63
10	0.03	0.13	0.44	2.57	7.03	22.51	50.56



SERVOBOX Planetary Reducers

MODEL : SB

2-Stage

RATIO : 15, 20, 25, 30, 35, 40, 50, 60, 70, 80, 90, 100

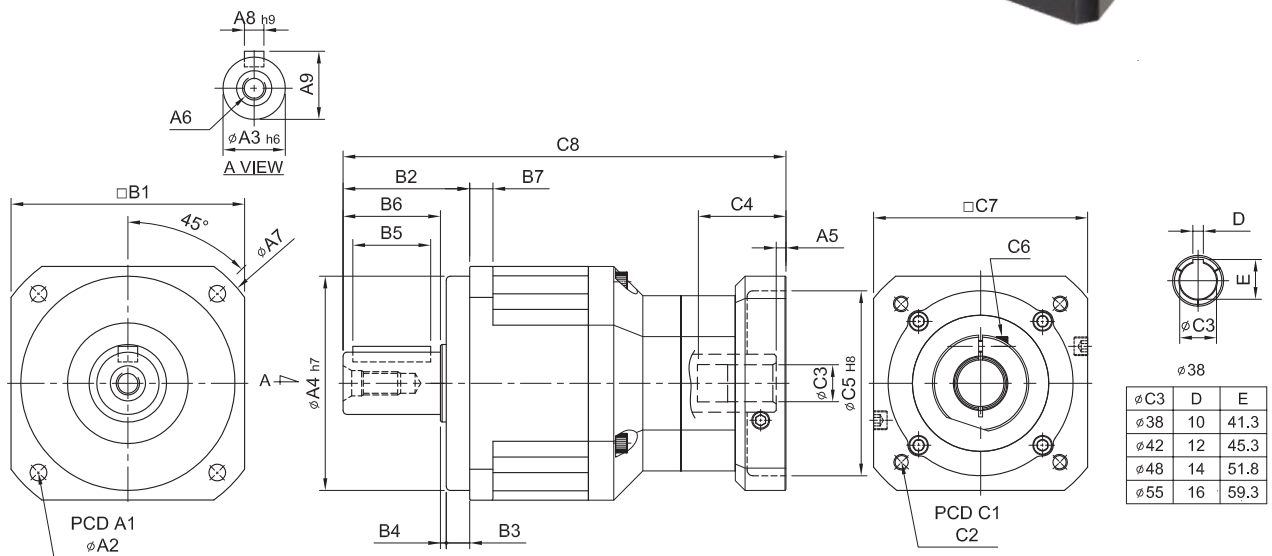

unit: mm

Model Code	62	90	120	142	180	220
A1	70	100	130	165	215	250
A2	5.5	6.8	9	11	13	17
A3	16	22	32	40	55	75
A4	50	80	110	130	160	180
A5	5	6	9 · 23.5	10 · 20	10	11.5 · 13.5
A6	M5 x P0.8	M8 x P1.25	M10 x P1.5	M12 x P1.75	M14 x P2.0	M16 x P2.0
A7	80	116	148	186	238	288
A8	5	6	10	12	16	20
A9	18	24.5	35	43	59	79.5
B1	62	90	120	142	180	220
B2	36	48	65	92	106	139
B3	7	10	12	15	20	30
B4	1	2	3	3	4	5
B5	20	30	40	65	70	90
B6	28	36	50	74	82	104
B7	8	10	12	15	16	20
C1	46 · 60 · 63	70 · 75 · 90	90 · 100 · 115 · 145	115 · 145 · 165	145 · 165 · 200	200 · 215 · 265
C2	M3 · M4 · M5	M4 · M5 · M6	M5 · M6 · M8 · M10	M6 · M8 · M10	M8 · M10 · M12	M10 · M12
C3	8 · 9 · 11	14 · 19	19 · 22 · 24	24 · 28 · 32	32 · 35 · 38	38 · 42 · 48 · 55
C4	26	33.5 · 41.5	59 · 73.5	67 · 77	84.5	114.5 · 116.5
C5	30 · 40 · 50	50 · 60 · 70	70 · 80 · 95 · 110	70 · 95 · 110 · 130	110 · 130 · 180	114.3 · 180 · 230
C6	M4 x P0.7	M5 x P0.8	M6 x P1.0	M8 x P1.25	M10 x P1.5	M10 x P1.5
C7	46 · 55	64 · 70 · 80	92 · 110 · 130	122 · 130 · 150	146 · 180 · 190	182 · 200 · 250
C8	139.5	172.5 · 180.5	241 · 255.5	298.5 · 308.5	358.5	446.5



SB
SBL
SBL SBT
SE
SEL
SD
SDL
SDD
SDH
SF
SFL
PB
PBL
PBT
FA
SN
FB
FE

High Precision Planetary Reducer

Model No.		Unit	Ratio	62	90	120	142	180	220
Rated Output Torque (Nominal output torque)	T_{2N}	Nm	15	59	165	335	625	1,206	2,030
			20	51	146	300	555	1,069	1,804
			25	48	160	333	618	1,189	2,010
			30	45	151	311	583	1,118	1,911
			35	45	149	309	573	1,108	1,870
			40	43	143	298	553	1,070	1,824
			50	48	160	333	618	1,189	2,010
			60	45	151	311	583	1,118	1,911
			70	45	149	309	573	1,108	1,870
			80	43	143	298	553	1,070	1,824
			90	44	145	278	516	993	1,694
100	43	141	294	549	1,059	1,779			
Max. Acceleration Torque	T_{2B}	Nm	15 ~ 100	1.8 Times of Rated Output Torque					
Max. Output Torque Emergency Stop Torque	T_{2NOT}	Nm	15 ~ 100	3 Times of Rated Output Torque					
Rated Input Speed	n_{IN}	rpm	15 ~ 100	3,000	3,000	3,000	3,000	3,000	2,000
Max. Input Speed	n_{IB}	rpm	15 ~ 100	6,000	6,000	5,000	5,000	4,000	3,000
Backlash Ps		arcmin	15 ~ 100	-	-	≤ 3	≤ 3	≤ 3	≤ 3
Backlash P0		arcmin	15 ~ 100	≤ 5	≤ 5	≤ 5	≤ 5	≤ 5	≤ 5
Backlash P1		arcmin	15 ~ 100	≤ 7	≤ 7	≤ 7	≤ 7	≤ 7	≤ 7
Backlash P2		arcmin	15 ~ 100	≤ 9	≤ 9	≤ 9	≤ 9	≤ 9	≤ 9
Torsional Rigidity		Nm/arcmin	15 ~ 100	6	14	27	60	140	240
Max. Radial Force	F_{2rB}	N	15 ~ 100	1,180	3,200	6,800	9,300	15,600	51,000
Max. Axial Force	F_{2aB}	N	15 ~ 100	590	1,600	3,400	4,650	7,800	25,500
Service Life	L_H	hr	15 ~ 100	S5 Cycle Operation: >30,000 (S1 Continuous Operation: >15,000 hrs)					
Efficiency	η	%	15 ~ 100	≥ 94					
Operating Temperature		°C	15 ~ 100	- 25° C ~ + 90° C					
Lubrication			15 ~ 100	Synthetic Grease					
Protection Class			15 ~ 100	IP65					
Mounting Position			15 ~ 100	Any					
Noise Level		dB	15 ~ 100	≤ 58	≤ 60	≤ 63	≤ 65	≤ 67	≤ 70
Weight ±3%		Kg	15 ~ 100	1.73	4.6	9.42	17.2	34.1	57.3

■ Mass Moments of Inertia (kg.cm²)

Ratio	62	90	120	142	180	220
15	0.03	0.14	0.46	2.63	7.3	22.79
20	0.03	0.14	0.46	2.63	7.3	22.79
25	0.03	0.14	0.46	2.63	7.1	22.79
30	0.03	0.14	0.46	2.43	7.1	22.59
35	0.03	0.14	0.44	2.43	7.1	22.59
40	0.03	0.14	0.44	2.43	6.92	22.59
50	0.03	0.14	0.44	2.43	6.92	22.59
60	0.03	0.14	0.43	2.39	6.72	21.83
70	0.03	0.14	0.43	2.39	6.72	21.83
80	0.03	0.14	0.43	2.39	6.72	21.83
90	0.03	0.14	0.40	2.39	6.72	21.60
100	0.03	0.14	0.40	2.39	6.72	21.60



SERVOBOX Planetary Reducers

MODEL : SB-A

2-Stage

RATIO : 15, 20, 25, 30, 35, 40, 50, 60, 70, 80, 90, 100

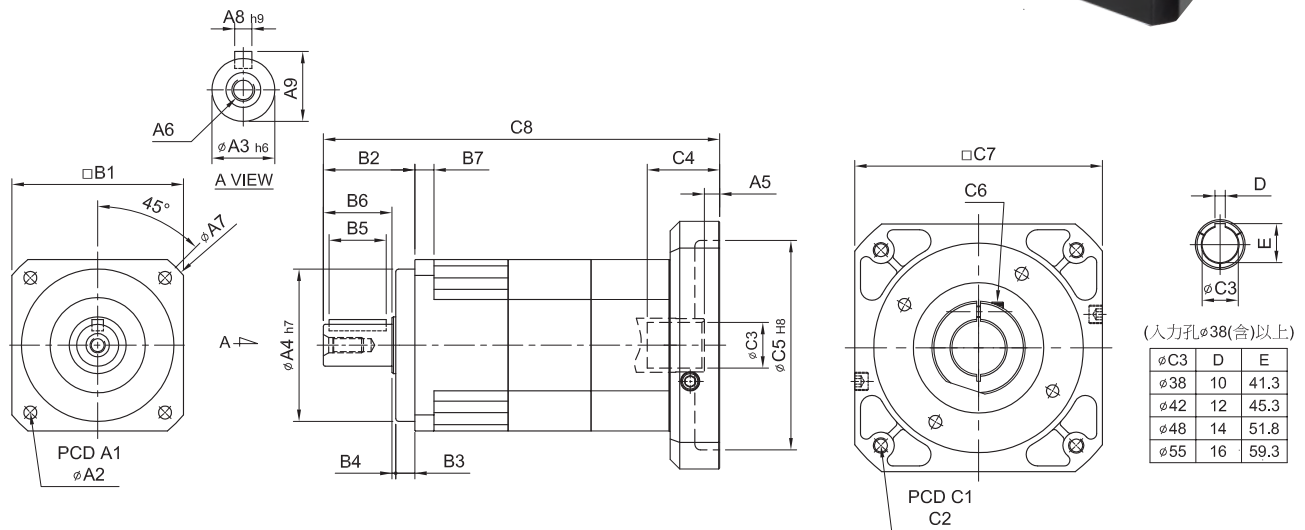

(入力孔 $\phi 38$ (含)以上)

$\phi C3$	D	E
$\phi 38$	10	41.3
$\phi 42$	12	45.3
$\phi 48$	14	51.8
$\phi 55$	16	59.3

unit: mm

Model Code	44A	62A	90A	120A	142A	180A	220A
A1	50	70	100	130	165	215	250
A2	4.5	5.5	6.8	9	11	13	17
A3	13	16	22	32	40	55	75
A4	35	50	80	110	130	160	180
A5	5	6	9 · 23.5	10 · 20	10	11.5 · 13.5	12.5 · 14.5
A6	M4 x P0.7	M5 x P0.8	M8 x P1.25	M10 x P1.5	M12 x P1.75	M14 x P2.0	M16 x P2.0
A7	58	80	116	148	186	238	288
A8	5	5	6	10	12	16	20
A9	15	18	24.5	35	43	59	79.5
B1	44	62	90	120	142	180	220
B2	26	36	48	65	92	106	139
B3	5	7	10	12	15	20	30
B4	1	1	2	3	3	4	5
B5	15	20	30	40	65	70	90
B6	20	28	36	50	74	82	104
B7	5	8	10	12	15	16	20
C1	46 · 60 · 63	70 · 75 · 90	90 · 100 · 115 · 145	115 · 145 · 165	145 · 165 · 200	200 · 215 · 265	200 · 265 · 300
C2	M3 · M4 · M5	M4 · M5 · M6	M5 · M6 · M8	M6 · M8 · M10	M8 · M10 · M12	M10 · M12	M12 · M16
C3	8 · 9 · 11	14 · 19	19 · 22 · 24	24 · 28 · 32	32 · 35 · 38	38 · 42 · 48 · 55	42 · 48 · 55
C4	26	33.5 · 41.5	59 · 73.5	67 · 77	84.5	114.5 · 116.5	117.5 · 119.5
C5	30 · 40 · 50	50 · 60 · 70	70 · 80 · 95 · 110	95 · 110 · 130	110 · 130 · 180	114.3 · 180 · 230	114.3 · 230 · 250
C6	M4 x P0.7	M5 x P0.8	M6 x P1.0	M8 x P1.5	M10 x P1.5	M10 x P1.5	M10 x P1.5
C7	46 · 55	64 · 70 · 80	92 · 110 · 130	122 · 130 · 150	146 · 150 · 190	182 · 200 · 250	222 · 250 · 265
C8	121	148.8 · 156.8	208 · 222.5	261 · 271	327	404.5	460.5



High Precision Planetary Reducer

Model No.		Unit	Ratio	44A	62A	90A	120A	142A	180A	220A
Rated Output Torque (Nominal output torque)	T_{2N}	Nm	15	19	59	165	335	625	1,206	2,030
			20	16	51	146	300	555	1,069	1,804
			25	16	48	160	333	618	1,189	2,010
			30	15	45	151	311	583	1,118	1,911
			35	15	45	149	309	573	1,108	1,870
			40	14	43	143	298	553	1,070	1,824
			50	16	48	160	333	618	1,189	2,010
			60	15	45	151	311	583	1,118	1,911
			70	15	45	149	309	573	1,108	1,870
			80	14	43	143	298	553	1,070	1,824
			90	13	44	145	278	516	993	1,694
			100	14	43	141	294	549	1,059	1,779
Max. Acceleration Torque	T_{2B}	Nm	15 ~ 100	1.8 Times of Rated Output Torque						
Max. Output Torque Emergency Stop Torque	T_{2NOT}	Nm	15 ~ 100	3 Times of Rated Output Torque						
Rated Input Speed	n_{IN}	rpm	15 ~ 100	3,000	3,000	3,000	3,000	3,000	3,000	2,000
Max. Input Speed	n_{IB}	rpm	15 ~ 100	6,000	6,000	6,000	5,000	5,000	4,000	3,000
Backlash Ps		arcmin	15 ~ 100	-	-	-	≤ 3	≤ 3	≤ 3	≤ 3
Backlash P0		arcmin	15 ~ 100	≤ 5	≤ 5	≤ 5	≤ 5	≤ 5	≤ 5	≤ 5
Backlash P1		arcmin	15 ~ 100	≤ 7	≤ 7	≤ 7	≤ 7	≤ 7	≤ 7	≤ 7
Backlash P2		arcmin	15 ~ 100	≤ 9	≤ 9	≤ 9	≤ 9	≤ 9	≤ 9	≤ 9
Torsional Rigidity		Nm/arcmin	15 ~ 100	3	6	14	27	60	140	240
Max. Radial Force	F_{2rB}	N	15 ~ 100	380	1,180	3,200	6,800	9,300	15,600	51,000
Max. Axial Force	F_{2aB}	N	15 ~ 100	190	590	1,600	3,400	4,650	7,800	25,500
Service Life	L_H	hr	15 ~ 100	S5 Cycle Operation: >30,000 (S1 Continuous Operation: >15,000 hrs)						
Efficiency	η	%	15 ~ 100	≥ 94						
Operating Temperature		°C	15 ~ 100	- 25° C ~ + 90° C						
Lubrication			15 ~ 100	Synthetic Grease						
Protection Class			15 ~ 100	IP65						
Mounting Position			15 ~ 100	Any						
Noise Level		dB	15 ~ 100	≤ 56	≤ 58	≤ 60	≤ 63	≤ 65	≤ 67	≤ 70
Weight ±3%		Kg	15 ~ 100	0.6	2	5.5	11	21	42	59

■ Mass Moments of Inertia (kg.cm²)

Ratio	44A	62A	90A	120A	142A	180A	220A
15	0.03	0.14	0.46	2.63	7.30	22.79	56.98
20	0.03	0.14	0.46	2.63	7.30	22.79	56.98
25	0.03	0.14	0.46	2.63	7.10	22.79	56.98
30	0.03	0.14	0.46	2.43	7.10	22.59	56.48
35	0.03	0.14	0.44	2.43	7.10	22.59	56.48
40	0.03	0.14	0.44	2.43	6.92	22.59	56.48
50	0.03	0.14	0.44	2.43	6.92	22.59	56.48
60	0.03	0.14	0.43	2.39	6.72	21.83	54.58
70	0.03	0.14	0.43	2.39	6.72	21.83	54.58
80	0.03	0.14	0.43	2.39	6.72	21.83	54.58
90	0.03	0.14	0.40	2.39	6.72	21.60	54.00
100	0.03	0.14	0.43	2.39	6.72	21.83	54.58



SERVOBOX Planetary Reducers

MODEL : SB

3-Stage

RATIO : 125, 150, 175, 200, 250, 300, 350,
400, 450, 500, 600, 700, 800, 900, 1000

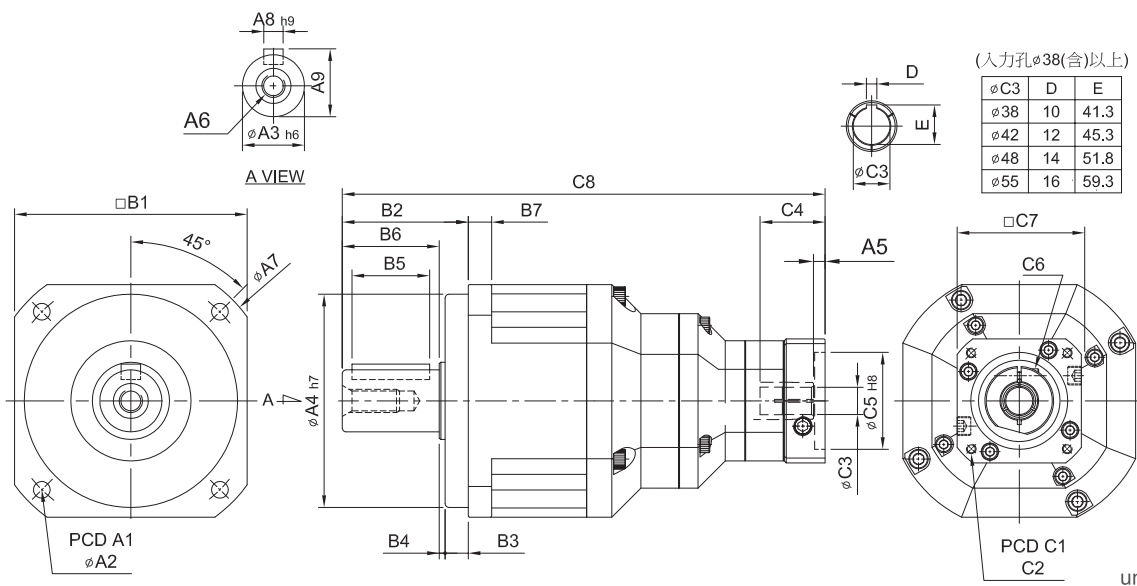

Model Code	90	120	142	180	220
A1	100	130	165	215	250
A2	6.8	9	11	13	17
A3	22	32	40	55	75
A4	80	110	130	160	180
A5	5	6	9·23.5	10·20	10
A6	M8 x P1.25	M10 x P1.5	M12 x P1.75	M14 x P2.0	M16 x P2.0
A7	116	148	186	238	288
A8	6	10	12	16	20
A9	24.5	35	43	59	79.5
B1	90	120	142	180	220
B2	48	65	92	106	139
B3	10	12	15	20	30
B4	2	3	3	4	5
B5	30	40	65	70	90
B6	36	50	74	82	104
B7	10	12	15	16	20
C1	46·60·63	70·75·90	90·100·115·145	115·145·165	145·165·200
C2	M3·M4·M5	M4·M5·M6	M5·M6·M8	M6·M8·M10	M8·M10·M12
C3	8·9·11	14·19	19·22·24	24·28·32	32·35·38
C4	26	33.5·41.5	59·73.5	67·77	84.5
C5	30·40·50	50·60·70	70·80·95·110	95·110·130	110·130·180
C6	M4 x P0.7	M5 x P0.8	M6 x P1.0	M8 x P1.25	M10 x P1.5
C7	46·55	64·70·80	92·110·130	122·130·150	146·150·190
C8	197	249·257	334.5·349	396.5·406.5	481.5

- SB
- SBL
- SBT
- SE
- SEL
- SD
- SDL
- SDD
- SDH
- SF
- SFL
- PB
- PBL
- PBT
- FA
- SN
- FB
- FE



High Precision Planetary Reducer

Model No.		Unit	Ratio	90	120	142	180	220
Rated Output Torque (Nominal output torque)	T_{2N}	Nm	125	160	333	618	1,189	2,010
			150	165	335	625	1,206	2,030
			175	149	309	573	1,108	1,870
			200	146	300	555	1,069	1,804
			250	160	333	618	1,189	2,010
			300	151	311	583	1,118	1,911
			350	149	309	573	1,108	1,870
			400	143	298	553	1,070	1,824
			450	145	278	516	993	1,694
			500	160	333	618	1,189	2,010
			600	151	311	583	1,118	1,911
			700	149	309	573	1,108	1,870
800	143	298	553	1,070	1,824			
900	145	278	516	993	1,694			
1000	141	294	549	1,059	1,779			
Max. Acceleration Torque	T_{2B}	Nm	125 ~ 1000	1.8 Times of Rated Output Torque				
Max. Output Torque Emergency Stop Torque	T_{2NOT}	Nm	125 ~ 1000	3 Times of Rated Output Torque				
Rated Input Speed	n_{1N}	rpm	125 ~ 1000	3,000	3,000	3,000	3,000	2,000
Max. Input Speed	n_{1B}	rpm	125 ~ 1000	6,000	5,000	5,000	4,000	3,000
Backlash Ps		arcmin	125 ~ 1000	-	≤ 5	≤ 5	≤ 5	≤ 5
Backlash P0		arcmin	125 ~ 1000	≤ 7	≤ 7	≤ 7	≤ 7	≤ 7
Backlash P1		arcmin	125 ~ 1000	≤ 9	≤ 9	≤ 9	≤ 9	≤ 9
Backlash P2		arcmin	125 ~ 1000	≤ 11	≤ 11	≤ 11	≤ 11	≤ 11
Torsional Rigidity		Nm/arcmin	125 ~ 1000	14	27	60	140	240
Max. Radial Force	F_{2rB}	N	125 ~ 1000	3,200	6,800	9,300	15,600	51,000
Max. Axial Force	F_{2aB}	N	125 ~ 1000	1,600	3,400	4,650	7,800	25,500
Service Life	L_H	hr	125 ~ 1000	S5 Cycle Operation: >30,000 (S1 Continuous Operation: >15,000 hrs)				
Efficiency	η	%	125 ~ 1000	≥ 90				
Operating Temperature		°C	125 ~ 1000	- 25° C ~ + 90° C				
Lubrication			125 ~ 1000	Synthetic Grease				
Protection Class			125 ~ 1000	IP65				
Mounting Position			125 ~ 1000	Any				
Noise Level		dB	125 ~ 1000	≤ 60	≤ 63	≤ 65	≤ 67	≤ 70
Weight ±3%		Kg	125 ~ 1000	5.2	10	18.1	35	63.7

■ Mass Moments of Inertia (kg.cm²)

Ratio	90	120	142	180	220
125	0.01	0.04	0.71	1.42	3.29
150	0.01	0.04	0.51	0.92	2.15
175	0.01	0.04	0.40	0.83	1.26
200	0.01	0.04	0.21	0.65	0.98
250	0.01	0.04	0.11	0.52	0.82
300	0.01	0.04	0.09	0.21	0.82
350	0.01	0.04	0.09	0.21	0.82
400	0.01	0.04	0.09	0.21	0.82
450	0.01	0.04	0.09	0.21	0.51
500	0.01	0.04	0.08	0.12	0.51
600	0.01	0.04	0.08	0.12	0.25
700	0.01	0.04	0.08	0.12	0.25
800	0.01	0.04	0.08	0.12	0.25
900	0.01	0.04	0.08	0.12	0.25
1000	0.01	0.04	0.08	0.12	0.25



SERVOBOX Planetary Reducers

MODEL : SB-A

3-Stage

RATIO : 125, 150, 175, 200, 250, 300, 350,
400, 450, 500, 600, 700, 800, 900, 1000

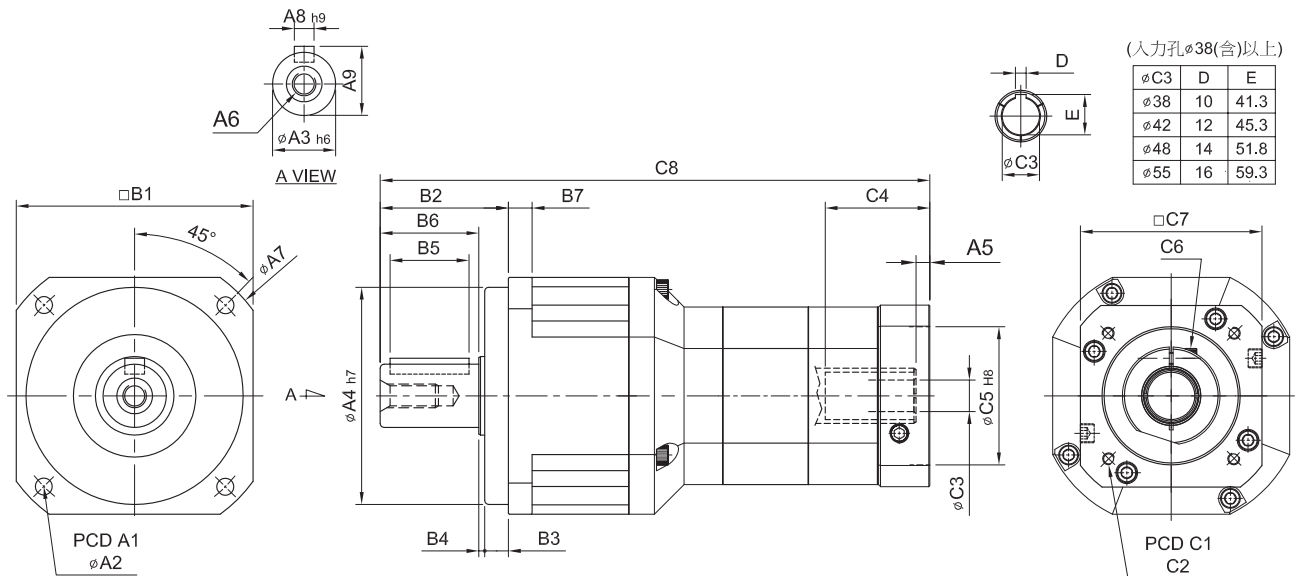

unit: mm

Model Code	62A	90A	120A	142A	180A	220A
A1	70	100	130	165	215	250
A2	5.5	6.8	9	11	13	17
A3	16	22	32	40	55	75
A4	50	80	110	130	160	180
A5	5	6	9 · 23.5	10 · 20	10	11.5 · 13.5
A6	M5 x P0.8	M8 x P1.25	M10 x P1.5	M12 x P1.75	M14 x P2.0	M16 x P2.0
A7	80	116	148	186	238	288
A8	5	6	10	12	16	20
A9	18	24.5	35	43	59	79.5
B1	62	90	120	142	180	220
B2	36	48	65	92	106	139
B3	7	10	12	15	20	30
B4	1	2	3	3	4	5
B5	20	30	40	65	70	90
B6	28	36	50	74	82	104
B7	8	10	12	15	16	20
C1	46 · 63 · 60	70 · 75 · 90	90 · 100 · 115 · 145	115 · 145 · 165	145 · 165 · 200	200 · 215 · 265
C2	M3 · M4 · M5	M4 · M5 · M6	M5 · M6 · M8	M6 · M8 · M10	M8 · M10 · M12	M10 · M12
C3	8 · 9 · 11	14 · 19	19 · 22 · 24	24 · 28 · 32	32 · 35 · 38	38 · 42 · 48 · 55
C4	26	33.5 · 41.5	59 · 73.5	67 · 77	84.5	114.5 · 116.5
C5	30 · 40 · 50	50 · 60 · 70	70 · 80 · 95 · 110	95 · 110 · 130	110 · 130 · 180	114.3 · 180 · 230
C6	M4 x P0.7	M5 x P0.8	M6 x P1.0	M8 x P1.25	M10 x P1.5	M10 x P1.5
C7	46 · 55	64 · 70 · 80	92 · 110 · 130	122 · 130 · 150	146 · 150 · 190	182 · 200 · 250
C8	165.5	206.3 · 214.3	284.5 · 299	354.5 · 364.5	425	527.5



High Precision Planetary Reducer

Model No.		Unit	Ratio	62A	90A	120A	142A	180A	220A
Rated Output Torque (Nominal output torque)	T_{2N}	Nm	125	48	160	333	618	1,189	2,010
			150	59	165	335	625	1,206	2,030
			175	45	149	309	573	1,108	1,870
			200	51	146	300	555	1,069	1,804
			250	48	160	333	618	1,189	2,010
			300	45	151	311	583	1,118	1,911
			350	45	149	309	573	1,108	1,870
			400	43	143	298	553	1,070	1,824
			450	44	145	278	516	993	1,694
			500	48	160	333	618	1,189	2,010
			600	45	151	311	583	1,118	1,911
			700	45	149	309	573	1,108	1,870
			800	43	143	298	553	1,070	1,824
900	44	145	278	516	993	1,694			
1000	43	141	294	549	1,059	1,779			
Max. Acceleration Torque	T_{2B}	Nm	125 ~ 1000	1.8 Times of Rated Output Torque					
Max. Output Torque Emergency Stop Torque	T_{2NOT}	Nm	125 ~ 1000	3 Times of Rated Output Torque					
Rated Input Speed	n_{1N}	rpm	125 ~ 1000	3,000	3,000	3,000	3,000	3,000	2,000
Max. Input Speed	n_{1B}	rpm	125 ~ 1000	6,000	6,000	5,000	5,000	4,000	3,000
Backlash Ps		arcmin	125 ~ 1000	-	-	≤ 5	≤ 5	≤ 5	≤ 5
Backlash P0		arcmin	125 ~ 1000	≤ 7	≤ 7	≤ 7	≤ 7	≤ 7	≤ 7
Backlash P1		arcmin	125 ~ 1000	≤ 9	≤ 9	≤ 9	≤ 9	≤ 9	≤ 9
Backlash P2		arcmin	125 ~ 1000	≤ 11	≤ 11	≤ 11	≤ 11	≤ 11	≤ 11
Torsional Rigidity		Nm/arcmin	125 ~ 1000	6	14	27	60	140	240
Max. Radial Force	F_{2rB}	N	125 ~ 1000	1,180	3,200	6,800	9,300	15,600	51,000
Max. Axial Force	F_{2aB}	N	125 ~ 1000	590	1,600	3,400	4,650	7,800	25,500
Service Life	L_H	hr	125 ~ 1000	S5 Cycle Operation: >30,000 (S1 Continuous Operation: >15,000 hrs)					
Efficiency	η	%	125 ~ 1000	≥ 90					
Operating Temperature		°C	125 ~ 1000	- 25° C ~ + 90° C					
Lubrication			125 ~ 1000	Synthetic Grease					
Protection Class			125 ~ 1000	IP65					
Mounting Position			125 ~ 1000	Any					
Noise Level		dB	125 ~ 1000	≤ 58	≤ 60	≤ 63	≤ 65	≤ 67	≤ 70
Weight ±3%		Kg	125 ~ 1000	4	6.5	13	30	57	87

■ Mass Moments of Inertia (kg.cm²)

Ratio	62A	90A	120A	142A	180A	220A
125	0.01	0.01	0.04	0.71	1.42	3.29
150	0.01	0.01	0.04	0.51	0.92	2.15
175	0.01	0.01	0.04	0.40	0.83	1.26
200	0.01	0.01	0.04	0.21	0.65	0.98
250	0.01	0.01	0.04	0.11	0.52	0.82
300	0.01	0.01	0.04	0.09	0.21	0.82
350	0.01	0.01	0.04	0.09	0.21	0.82
400	0.01	0.01	0.04	0.09	0.21	0.82
450	0.01	0.01	0.04	0.09	0.21	0.51
500	0.01	0.01	0.04	0.08	0.12	0.51
600	0.01	0.01	0.04	0.08	0.12	0.25
700	0.01	0.01	0.04	0.08	0.12	0.25
800	0.01	0.01	0.04	0.08	0.12	0.25
900	0.01	0.01	0.04	0.08	0.12	0.25
1000	0.01	0.01	0.04	0.08	0.12	0.25



FB series



■ 1-Stage Backlash ≤ 8 arcmin

■ 2-Stage Backlash ≤ 12 arcmin

Indication of Model Numbers

FB	90	10		MOTOR
Type	Model	Ratio	Output Shaft Keyway	Motor Type
FB FE	50 70 90 120 145 180 220	1-Stage 3, 4, 5, 7, 10 2-Stage 15, 20, 25, 30, 35, 40, 50, 70, 100	<input type="checkbox"/> Standard (Keyway) N: Solid Output Shaft (No Keyway)	

- SB
- SBL
- SBT
- SE
- SEL
- SD
- SDL
- SDD
- SDH
- SF
- SFL
- PB
- PBL
- PBT
- FA
- SN
- FB**
- FE



Features of FB Series



Integrated Planetary Arm Bracket

The planetary arm bracket and the output shaft are one-piece constructed to increase torsional rigidity and accuracy. The entire structure is integrated machined for controlling accuracy in the specified tolerance.

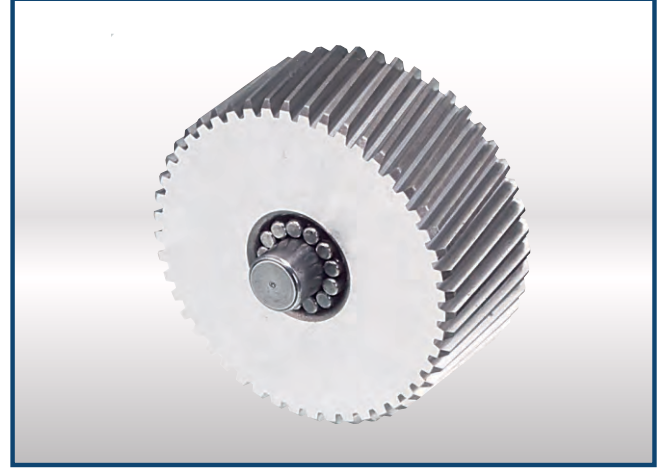

Full Needle Roller Bearings Design

The planetary gear transmission employs full needle roller bearings without retainer to increase the contact surface, which greatly upgrades structural rigidity and service life.

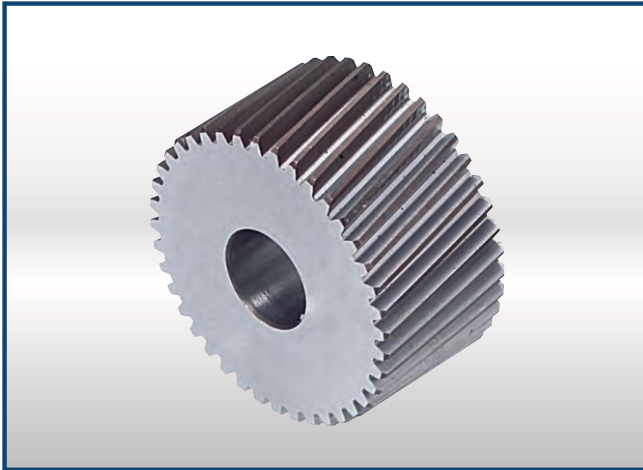

High Precision Gear Machining

The planetary gear and sun gear are manufactured from high quality Ni-Cr-Mo alloy steel (SNM220), precision machined and carburizing heat treatment to hardness 57-60 HRC. Precision teeth grinding or skiving assures gear accuracy reaches DIN6 class.

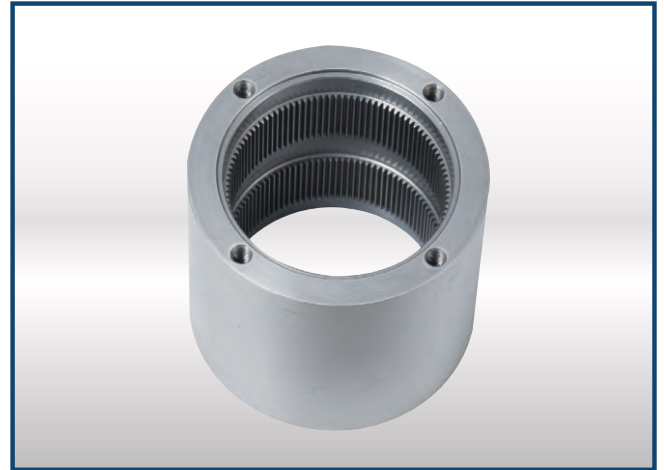

One-piece Gearbox Housing

The gearbox and internal ring gear are one-piece constructed. High gear accuracy meets DIN6 class.



PRECISION PLANETARY REDUCERS

MODEL : FB

RATIO : 3, 4, 5, 7, 10 (1-Stage)

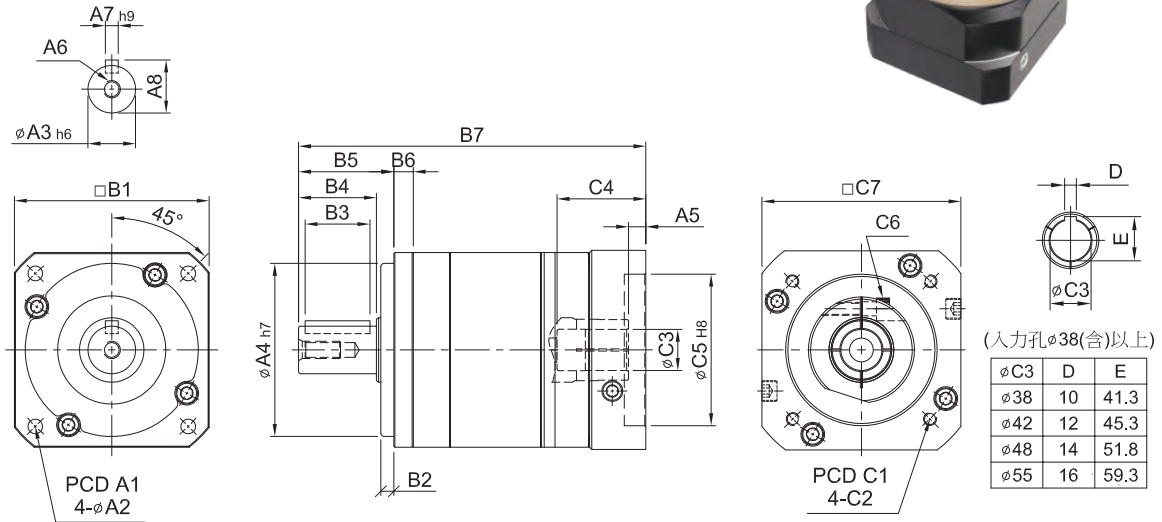

unit : mm

Model Code	50	70	90	120	145	180	220	
A	A1	50	70	100	130	165	215	250
	A2	4.5	6	6.8	9	11	13	17
	A3	13	16	22	32	40	55	75
	A4	35	50	80	110	130	160	180
	A5	5	6	9·23.5	10·20	10	13·15	13.5·15.5
	A6	M4 x P0.7	M5 x P0.8	M8 x P1.25	M10 x P1.5	M12 x P1.75	M14 x P2.0	M16 x P2.0
	A7	5	5	6	10	12	16	20
	A8	15	18	24.5	35	43	59	81
B	B1	50	70	90	120	145	180	220
	B2	4	5	8	8	10	20	20
	B3	15	20	30	40	65	70	90
	B4	20	28	36	50	74	82	104
	B5	25	34	44	60	87	106	129
	B6	6	8	9	12	15	16	24
	B7	100.5	132.5	170.5·185	227.5	291	325·327	377·379
C	C1	46·60·63	70·75·90	90·100·115·145	115·145·165	145·165·200	200·215·265	200·265·300
	C2	M3 M4 M5	M4 M5 M6	M5 M6 M8	M6 M8 M10	M8 M10 M12	M10 M12	M12 M16
	C3	8·9·11	14·19	19·22·24	24·28·32	35·38	38·42·48	42·48·55
	C4	26	33.5	51·65.5	63·73	81.5	115·117	118·120
	C5	30·40·50	40·50·60	70·80·95·110	95·110·130	110·130·180	114.3·180·230	114.3·230·250
	C6	M4 x P0.7	M5 x P0.8	M6 x P1.0	M8 x P1.25	M10 x P1.5	M10 x P1.5	M10 x P1.5
	C7	46·55	64·70·80	92·110·130	122·130·150	146·150·190	182·200·250	222·250·265

- SB
- SBL
- SBL SBT
- SE
- SEL
- SD
- SDL
- SDD
- SDH
- SF
- SFL
- PB
- PBL
- PBT
- FA
- SN
- FB**
- FE



Characteristic of FB 1-Stage

Model No.		Unit	Ratio	50	70	90	120	145	180	220
Rated Output Torque (Nominal output torque)	T_{2N}	Nm	3	17	50	125	268	482	940	1,420
			4	15	45	111	238	426	860	1,300
			5	14	42	104	223	401	835	1,270
			7	13	39	98	208	373	790	1,180
			10	12	37	92	198	356	760	1,140
Max. Acceleration Torque	T_{2B}	Nm	3~10	1.8 Times of Rated Output Torque						
Max. Output Torque Emergency Stop Torque	T_{2NOT}	Nm	3~10	3 Times of Rated Output Torque						
Rated Input Speed	n_{IN}	rpm	3~10	3,000	3,000	3,000	3,000	3,000	2,000	2,000
Max. Input Speed	n_{IB}	rpm	3~10	5,000	5,000	5,000	5,000	5,000	3,000	3,000
Backlash		arcmin	3~10	≤ 8	≤ 8	≤ 8	≤ 8	≤ 8	≤ 8	≤ 8
Torsional Rigidity		Nm/arcmin	3~10	2.3	5	15	45	69	140	220
Max. Radial Force	F_{2rB}	N	3~10	750	1,180	3,000	6,500	9,100	11,150	35,000
Max. Axial Force	F_{2aB}	N	3~10	325	590	1,500	3,250	4,550	5,575	17,500
Service Life	L_H	hr	3~10	S5 Cycle Operation: >20,000 (S1 Continuous Operation: >10,000 hrs)						
Efficiency	η	%	3~10	$\geq 97\%$						
Operating Temperature		°C	3~10	-25° C ~ +90° C						
Lubrication			3~10	Synthetic Grease						
Protection Class			3~10	IP65						
Mounting Position			3~10	Any						
Noise Level		dB	3~10	≤ 62	≤ 62	≤ 65	≤ 68	≤ 70	≤ 70	≤ 70
Weight $\pm 3\%$		Kg	3~10	0.63	1.57	3.22	8	16	33	54

Mass Moments of Inertia (kg.cm²)

Ratio	50	70	90	120	145	180	220
3	0.04	0.14	0.61	3.25	8.75	24.63	50.67
4	0.04	0.13	0.48	2.74	7.16	20.12	46.21
5	0.04	0.11	0.47	2.74	6.84	19.80	45.28
7	0.04	0.11	0.44	2.58	6.78	19.21	43.32
10	0.04	0.11	0.44	2.57	6.68	19.13	42.98



PRECISION PLANETARY REDUCERS

MODEL : FB

RATIO : 15, 20, 25, 30, 35, 40, 50, 70, 100 (2-Stage)

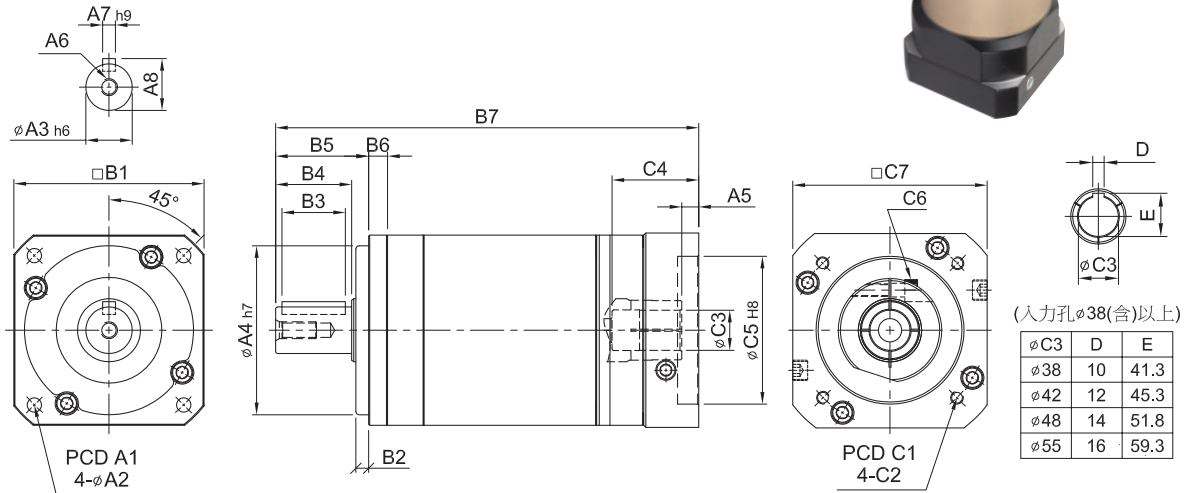

SB
SBL
SBL SBT
SE
SEL
SEL SD
SDL
SDL SDD
SDH
SF
SFL
PB
PBL
PBL PBT
FA
SN
FB
FE

unit : mm

Model Code	50	70	90	120	145	180	220	
A	A1	50	70	100	130	165	215	250
	A2	4.5	6	6.8	9	11	13	17
	A3	13	16	22	32	40	55	75
	A4	35	50	80	110	130	160	180
	A5	5	6	9・23.5	10・20	10	13・15	13.5・15.5
	A6	M4 x P0.7	M5 x P0.8	M8 x P1.25	M10 x P1.5	M12 x P1.75	M14 x P2.0	M16 x P2.0
	A7	5	5	6	10	12	16	20
	A8	15	18	24.5	35	43	59	81
B	B1	50	70	90	120	145	180	220
	B2	4	5	6	8	10	20	20
	B3	15	20	30	40	65	70	90
	B4	20	28	36	50	74	82	104
	B5	25	34	44	60	87	106	129
	B6	6	8	9	12	15	16	24
	B7	126.7	166.5	210.2・224.7	281.5・291.5	354.7	394.5・396.5	464
C	C1	46・60・63	70・75・90	90・100・115・145	115・145・165	145・165・200	200・215・265	200・265・300
	C2	M3 M4 M5	M4 M5 M6	M5 M6 M8	M6 M8 M10	M8 M10 M12	M10 M12	M12 M16
	C3	8・9・11	14・19	19・22・24	24・28・32	35・38	38・42・48	42・48・55
	C4	26	33.5	51・65.5	63・73	81.5	115・117	118・120
	C5	30・40・50	40・50・60	70・80・95・110	95・110・130	110・130・180	114.3・180・230	114.3・230・250
	C6	M4 x P0.7	M5 x P0.8	M6 x P1.0	M8 x P1.25	M10 x P1.5	M10 x P1.5	M10 x P1.5
	C7	46・55	64・70・80	92・110・130	122・130・150	146・150・190	182・200・250	222・250・265



Characteristic of FB 2-Stage

Model No.		Unit	Ratio	50	70	90	120	145	180	220
Rated Output Torque (Nominal output torque)	T_{2N}	Nm	15	17	50	125	268	482	940	1,420
			20	15	45	111	238	426	860	1,300
			25	14	42	104	223	401	835	1,270
			30	17	50	125	268	482	940	1,420
			35	13	39	98	208	373	790	1,180
			40	15	45	111	238	427	860	1,300
			50	14	42	104	223	402	835	1,270
			70	13	40	98	208	373	790	1,180
			100	12	37	92	198	357	760	1,100
Max. Acceleration Torque	T_{2B}	Nm	15~100	1.8 Times of Rated Output Torque						
Max. Output Torque Emergency Stop Torque	T_{2NOT}	Nm	15~100	3 Times of Rated Output Torque						
Rated Input Speed	n_{1N}	rpm	15~100	3,000	3,000	3,000	3,000	3,000	2,000	2,000
Max. Input Speed	n_{1B}	rpm	15~100	5,000	5,000	5,000	5,000	5,000	3,000	3,000
Backlash		arcmin	15~100	≤ 12	≤ 12	≤ 12	≤ 12	≤ 12	≤ 12	≤ 12
Torsional Rigidity		Nm/arcmin	15~100	2.3	5	15	45	69	140	220
Max. Radial Force	F_{2rB}	N	15~100	750	1,180	3,000	6,500	9,100	11,150	35,000
Max. Axial Force	F_{2aB}	N	15~100	325	590	1,500	3,250	4,550	5,575	17,500
Service Life	L_H	hr	15~100	S5 Cycle Operation: >20,000 (S1 Continuous Operation: >10,000 hrs)						
Efficiency	η	%	15~100	$\geq 94\%$						
Operating Temperature		°C	15~100	-25° C ~ +90° C						
Lubrication			15~100	Synthetic Grease						
Protection Class			15~100	IP65						
Mounting Position			15~100	Any						
Noise Level		dB	15~100	≤ 65	≤ 65	≤ 68	≤ 70	≤ 72	≤ 72	≤ 72
Weight $\pm 3\%$		Kg	15~100	0.9	2.24	4.59	11.22	22.5	46.4	75

Mass Moments of Inertia (kg.cm²)

Ratio	50	70	90	120	145	180	220
15	0.04	0.14	0.61	3.25	8.75	24.63	50.67
20	0.04	0.13	0.48	2.74	7.16	20.12	46.21
25	0.04	0.11	0.47	2.74	6.84	19.80	45.28
30	0.04	0.14	0.61	3.25	8.75	24.63	50.67
35	0.04	0.11	0.44	2.58	6.78	19.21	43.32
40	0.04	0.11	0.48	2.74	7.16	20.12	46.21
50	0.04	0.11	0.47	2.74	6.84	19.80	45.28
70	0.04	0.11	0.44	2.58	6.78	19.21	43.32
100	0.04	0.11	0.44	2.57	6.68	19.13	42.98



PRECISION PLANETARY REDUCERS

MODEL : FE

RATIO : 3, 4, 5, 7, 10 (1-Stage)

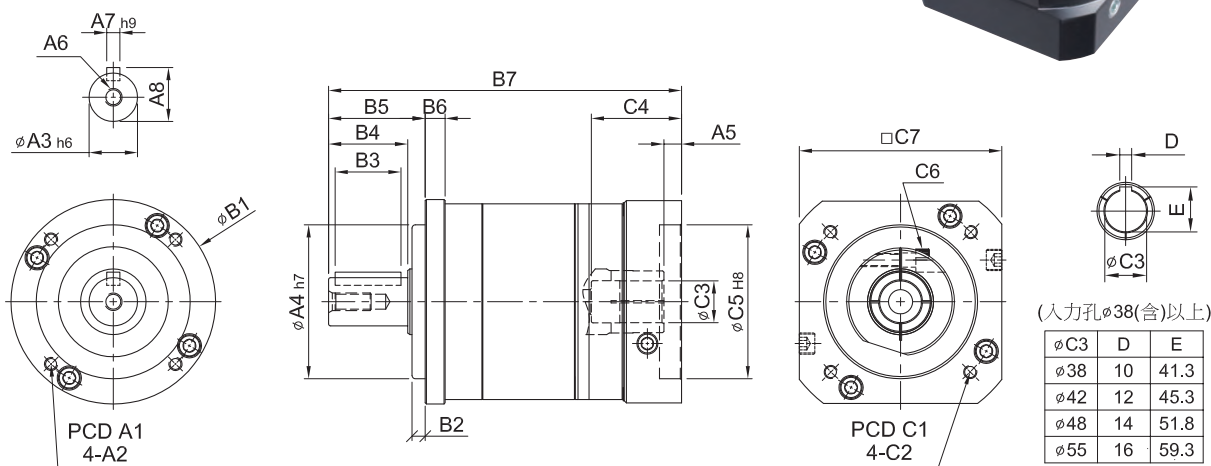

unit : mm

Model Code	50	70	90	120	145	180	220	
A	A1	42	60	80	105	130	184	218
	A2	M4 x P0.7	M5 x P0.8	M6 x P1.0	M8 x P1.25	M10 x P1.5	M12 x P1.75	M16 x P2.0
	A3	13	16	22	32	40	55	75
	A4	35	50	70	90	110	160	180
	A5	5	6	9 · 23.5	10 · 20	10	13 · 15	13.5 · 15.5
	A6	M4 x P0.7	M5 x P0.8	M8 x P1.25	M10 x P1.5	M12 x P1.75	M14 x P2.0	M16 x P2.0
	A7	5	5	6	10	12	16	20
	A8	15	18	24.5	35	43	59	79.5
B	B1	Ø50	Ø70	Ø93	Ø122	Ø148	Ø205	Ø242
	B2	4	5	6	8	10	20	20
	B3	15	20	30	40	65	70	90
	B4	20	28	36	50	74	82	104
	B5	25	34	44	60	87	106	129
	B6	6	8	9	12	15	21.5	30
	B7	100.5	132.5 · 140.5	170.5 · 185	227.5 · 237.5	291	325 · 327	376.5 · 378.5
C	C1	46 · 60 · 63	70 · 75 · 90	90 · 100 · 115 · 145	115 · 145 · 165	145 · 165 · 200	200 · 215 · 265	200 · 265 · 300
	C2	M3 M4 M5	M4 M5 M6	M5 M6 M8	M6 M8 M10	M8 M10 M12	M10 M12	M12 M16
	C3	8 · 9 · 11	14 · 19	19 · 22 · 24	24 · 28 · 32	35 · 38	38 · 42 · 48	42 · 48 · 55
	C4	26	33.5	51 · 65.5	63 · 73	81.5	115 · 117	118 · 120
	C5	30 · 40 · 50	40 · 50 · 60	70 · 80 · 95 · 110	95 · 110 · 130	110 · 130 · 180	114.3 · 180 · 230	114.3 · 230 · 250
	C6	M4 x P0.7	M5 x P0.8	M6 x P1.0	M8 x P1.25	M10 x P1.5	M10 x P1.5	M10 x P1.5
	C7	46 · 55	64 · 70 · 80	92 · 110 · 130	122 · 130 · 150	146 · 150 · 190	182 · 200 · 250	222 · 250 · 265



Characteristic of FE 1-Stage

Model No.		Unit	Ratio	50	70	90	120	145	180	220
Rated Output Torque (Nominal output torque)	T_{2N}	Nm	3	17	50	125	268	482	940	1,420
			4	15	45	111	238	426	860	1,300
			5	14	42	104	223	401	835	1,270
			7	13	39	98	208	373	790	1,180
			10	12	37	92	198	356	760	1,140
Max. Acceleration Torque	T_{2B}	Nm	3~10	1.8 Times of Rated Output Torque						
Max. Output Torque Emergency Stop Torque	T_{2NOT}	Nm	3~10	3 Times of Rated Output Torque						
Rated Input Speed	n_{1N}	rpm	3~10	3,000	3,000	3,000	3,000	3,000	2,000	2,000
Max. Input Speed	n_{1B}	rpm	3~10	5,000	5,000	5,000	5,000	5,000	3,000	3,000
Backlash		arcmin	3~10	≤ 8	≤ 8	≤ 8	≤ 8	≤ 8	≤ 8	≤ 8
Torsional Rigidity		Nm/arcmin	3~10	2.3	5	15	45	69	140	220
Max. Radial Force	F_{2rB}	N	3~10	750	1,180	3,000	6,500	9,100	11,150	35,000
Max. Axial Force	F_{2aB}	N	3~10	325	590	1,500	3,250	4,550	5,575	17,500
Service Life	L_H	hr	3~10	S5 Cycle Operation: >20,000 (S1 Continuous Operation: >10,000 hrs)						
Efficiency	η	%	3~10	≥ 97%						
Operating Temperature		°C	3~10	-25° C ~ +90° C						
Lubrication			3~10	Synthetic Grease						
Protection Class			3~10	IP65						
Mounting Position			3~10	Any						
Noise Level		dB	3~10	≤ 62	≤ 62	≤ 65	≤ 68	≤ 70	≤ 70	≤ 70
Weight ±3%		Kg	3~10	0.63	1.57	3.22	8	16	33	54

Mass Moments of Inertia (kg.cm²)

Ratio	50	70	90	120	145	180	220
3	0.04	0.14	0.61	3.25	8.75	24.63	50.67
4	0.04	0.13	0.48	2.74	7.16	20.12	46.21
5	0.04	0.11	0.47	2.74	6.84	19.80	45.28
7	0.04	0.11	0.44	2.58	6.78	19.21	43.32
10	0.04	0.11	0.44	2.57	6.68	19.13	42.98



PRECISION PLANETARY REDUCERS

MODEL : FE

RATIO : 15, 20, 25, 30, 35, 40, 50, 70, 100 (2-Stage)

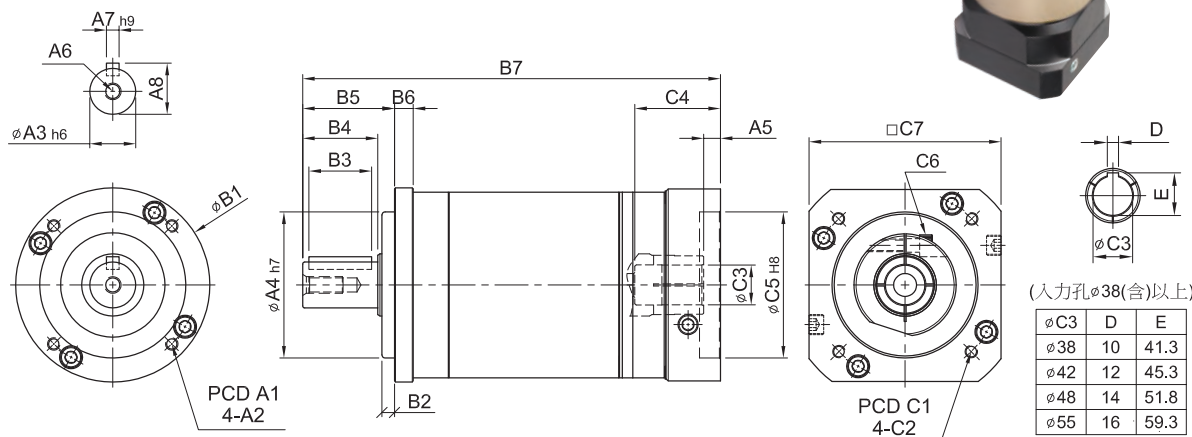

SB
SBL
SBL SBT
SE
SEL
SD
SDL
SDD
SDH
SF
SFL
PB
PBL
PBT
FA
SN
FB
FE

unit : mm

Model Code	50	70	90	120	145	180	220	
A	A1	42	60	80	105	130	218	
	A2	M4 x P0.7	M5 x P0.8	M6 x P1.0	M8 x P1.25	M10 x P1.5	M12 x P1.75	M16 x P2.0
	A3	13	16	22	32	40	55	75
	A4	35	50	70	90	110	160	180
	A5	5	6	9 · 23.5	10 · 20	10	13 · 15	13.5 · 15.5
	A6	M4 x P0.7	M5 x P0.8	M8 x P1.25	M10 x P1.5	M12 x P1.75	M14 x P2.0	M16 x P2.0
	A7	5	5	6	10	12	16	20
	A8	15	18	24.5	35	43	59	79.5
B	B1	$\phi 50$	$\phi 70$	$\phi 93$	$\phi 122$	$\phi 148$	$\phi 205$	$\phi 242$
	B2	4	5	6	8	10	20	20
	B3	15	20	30	40	65	70	90
	B4	20	28	36	50	74	82	104
	B5	25	34	44	60	87	106	129
	B6	6	8	9	12	15	21.5	30
	B7	126.7	166.5	210.2 · 224.7	281.5 · 291.5	354.7	394.5 · 396.5	463.5 · 465.5
C	C1	46 · 60 · 63	70 · 75 · 90	90 · 100 · 115 · 145	115 · 145 · 165	145 · 165 · 200	200 · 215 · 265	200 · 265 · 300
	C2	M3 M4 M5	M4 M5 M6	M5 M6 M8	M6 M8 M10	M8 M10 M12	M10 M12	M12 M16
	C3	8 · 9 · 11	14 · 19	19 · 22 · 24	24 · 28 · 32	35 · 38	38 · 42 · 48	42 · 48 · 55
	C4	26	33.5	51 · 65.5	63 · 73	81.5	115 · 117	118 · 120
	C5	30 · 40 · 50	40 · 50 · 60	70 · 80 · 95 · 110	95 · 110 · 130	110 · 130 · 180	114.3 · 180 · 230	114.3 · 230 · 250
	C6	M4 x P0.7	M5 x P0.8	M6 x P1.0	M8 x P1.25	M10 x P1.5	M10 x P1.5	M10 x P1.5
	C7	46 · 55	64 · 70 · 80	92 · 110 · 130	122 · 130 · 150	146 · 150 · 190	182 · 200 · 250	222 · 250 · 265



Characteristic of FE 2-Stage

Model No.		Unit	Ratio	50	70	90	120	145	180	220
Rated Output Torque (Nominal output torque)	T_{2N}	Nm	15	17	50	125	268	482	940	1,420
			20	15	45	111	238	426	860	1,300
			25	14	42	104	223	401	835	1,270
			30	17	50	125	268	482	940	1,420
			35	13	39	98	208	373	790	1,180
			40	15	45	111	238	427	860	1,300
			50	14	42	104	223	402	835	1,270
			70	13	40	98	208	373	790	1,180
			100	12	37	92	198	357	760	1,100
Max. Acceleration Torque	T_{2B}	Nm	15~100	1.8 Times of Rated Output Torque						
Max. Output Torque Emergency Stop Torque	T_{2NOT}	Nm	15~100	3 Times of Rated Output Torque						
Rated Input Speed	n_{IN}	rpm	15~100	3,000	3,000	3,000	3,000	3,000	2,000	2,000
Max. Input Speed	n_{IB}	rpm	15~100	5,000	5,000	5,000	5,000	5,000	3,000	3,000
Backlash		arcmin	15~100	≤ 12	≤ 12	≤ 12	≤ 12	≤ 12	≤ 12	≤ 12
Torsional Rigidity		Nm/arcmin	15~100	2.3	5	15	45	69	140	220
Max. Radial Force	F_{2rB}	N	15~100	750	1,180	3,000	6,500	9,100	11,150	35,000
Max. Axial Force	F_{2aB}	N	15~100	325	590	1,500	3,250	4,550	5,575	17,500
Service Life	L_{H1}	hr	15~100	S5 Cycle Operation: >20,000 (S1 Continuous Operation: >10,000 hrs)						
Efficiency	η	%	15~100	$\geq 94\%$						
Operating Temperature		°C	15~100	-25° C ~ +90° C						
Lubrication			15~100	synthetic Grease						
Protection Class			15~100	IP65						
Mounting Position			15~100	Any						
Noise Level		dB	15~100	≤ 65	≤ 65	≤ 68	≤ 70	≤ 72	≤ 72	≤ 72
Weight $\pm 3\%$		Kg	15~100	0.9	2.24	4.59	11.22	22.5	46.4	75

Mass Moments of Inertia (kg.cm²)

Ratio	50	70	90	120	142	180	220
15	0.04	0.14	0.61	3.25	8.75	24.63	50.67
20	0.04	0.13	0.48	2.74	7.16	20.12	46.21
25	0.04	0.11	0.47	2.74	6.84	19.80	45.28
30	0.04	0.14	0.61	3.25	8.75	24.63	50.67
35	0.04	0.11	0.44	2.58	6.78	19.21	43.32
40	0.04	0.11	0.48	2.74	7.16	20.12	46.21
50	0.04	0.11	0.47	2.74	6.84	19.80	45.28
70	0.04	0.11	0.44	2.58	6.78	19.21	43.32
100	0.04	0.11	0.44	2.57	6.68	19.13	42.98



Quality First & Customers Satisfaction

Collet Locking Mechanism

Collet Screw & Set Collar Torque Table

MODEL									Spec. of Collet Screw	Screw Grade	Tighten Torque (Nm)	Clench Torque (Nm)	key
SB SE	SBT PBT	SD	SDH	SF	PB	FA	SN	FB					
44	44	47	64	-	44	50	50 60	50	M4 x P 0.7	12.9	4.83	87	
62	62	64	90	62	62	70 80 90	70 80	70	M5 x P 0.8	12.9	10	164	
90	90 120	90	110	75	90	100	115	90	M6 x P 1.0	12.9	16.3	233	
120	142	110	140	100	120	120	-	120	M8 x P 1.25	12.9	41	423	
142	180	140	200	142	142	-	-	145	M10 x P 1.5	12.9	81	678	
180 220	-	200 255	255	180	180 220	-	-	180 220	M10 x P 1.5	12.9	81	678	●
270 330	-	-	-	-	-	-	-	-	M12 x P 1.75	12.9	110	813	●

It will cause slip when motor torque exceeds clench torque.

Input Bore	Ø38	Ø42	Ø48	Ø55	Ø60	Ø75
Key	10 x 8	12 x 8	14 x 9	16 x 10	18 x 11	20 x 12

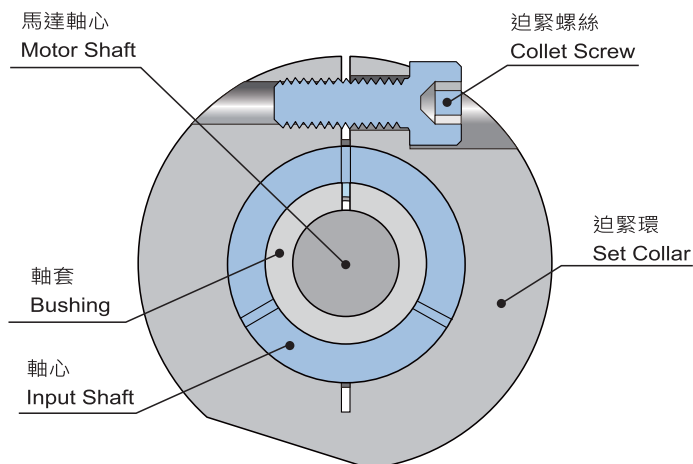



Reference Selection Table of Motor

1-Stage

Model	SB SE PB	44	-	-	62	90	120	142	-	-	180	220	270	330
	SB-A SE-A PB-A	44A	-	-	62A	90A	120A	142A	-	-	180A	220A	-	-
Power	SD	47	-	-	64	90	110	140	-	-	200	255	-	-
	SF	-	-	-	62	75	100	-	142	-	180	-	-	-
	SF-A	-	-	-	62A	75A	100A	-	142A	-	180A	-	-	-
	FA	-	50	-	80	100	120	-	-	-	-	-	-	-
	SN	-	50	60	70 80	115	-	-	-	-	-	-	-	-
	FB- FE	50	-	-	70	90	120	-	145	180	-	220	-	-
	Input Bore	8 9 11	8 10 11 14	8 9 10 12.7 14	14 19	19 22 24	24 28 32	28 32 35	35 38	38 42 48	38 42 48 55	42 48 55	48 55 60 70	55 60 75
100 W	●	●	●											
200 W	●	●	●											
400 W		●	●	●										
750 W				●	●									
1 kW					●									
1.5 kW					●	●								
2.2 kW						●	●							
3.75 kW						●	●	●						
5.5 kW							●	●	●	●				
7.5 kW								●	●	●				
11 kW									●	●	●			
15 kW									●	●	●			
22 kW									●	●	●	●		
30 kW										●	●	●	●	
37 kW													●	
45 kW													●	
55 kW													●	
75 kW													●	

The table is for reference. The selected model shall be based on rated output torque.



Reference Selection Table of Motor

2-Stage

Model	SB SE PB	-	62	-	-	-	90	-	120	-	142	-	180	-	-	-	-	220	270	330
	SBT PBT	44	-	-	-	62	-	90	-	120	-	142	-	-	180	-	-	-	-	-
Model	SDH	-	64	-	-	90	-	-	110	-	140	-	-	200	-	-	-	255	-	-
	SF	-	62	-	-	-	75	-	100	-	142	-	-	-	-	180	-	-	-	-
	FA	-	-	50	-	-	80	-	100	-	120	-	-	-	-	-	-	-	-	-
	SN	-	-	50	60	-	70 80	-	115	-	-	-	-	-	-	-	-	-	-	-
	FB FE	-	50	-	-	-	70	-	90	-	120	-	-	-	-	145	180	-	220	-
Power	Input Bore	8 11	8 9 11	8 10 11 14	8 9 10 12.7 14	14	14 19	19 24	19 22 24	22 24	24 28 32	28 32	28 32 35	28 32 38	35	35 38	38 42 48	38 42 48 55	42 48 55	48 55 60 70
100 W	•	•	•	•																
200 W	•	•	•	•																
400 W			•	•	•	•														
750 W						•	•	•												
1 kW									•	•										
1.5 kW								•	•	•	•									
2.2 kW											•	•	•	•						
3.75 kW											•	•	•	•	•	•				
5.5 kW													•	•	•	•	•	•		
7.5 kW														•		•	•	•		
11 kW																	•	•	•	
15 kW																	•	•	•	
22 kW																	•	•	•	•
30 kW																	•	•	•	

The table is for reference. The selected model shall be based on rated output torque.



Glossary

Gear Ratio (i)

The gear ratio i indicates the factor by which the gearhead transforms the three relevant parameters of motion (speed, torque and mass moment of inertia). The factor is a result of the geometry of the gearing elements (Example: $i = 10$).

$$\begin{array}{l} n_1 = 3000 \text{ rpm} \xrightarrow{\quad : i \quad} n_2 = 300 \text{ rpm} \\ T_1 = 20 \text{ Nm} \xrightarrow{\quad \cdot i \quad} T_2 = 200 \text{ Nm} \\ J_2 = 10 \text{ kgm}^2 \xrightarrow{\quad : i^2 \quad} J_1 = 0.10 \text{ kgm}^2 \end{array}$$

Input Speed (n_1) [rpm]

Input Speed is same as motor speed, if the motor direct connected gearbox.

Output Speed (n_2) [rpm]

The output speed is calculated by the formula related to input speed n_1 and reduction ratio i .

$$n_2 = \frac{n_1}{i}$$

Nominal Input Speed (n_{1N}) [rpm]

Input speed of gearbox shall be less than nominal input speed in the model of continuous operation (S1). Nominal input speed (n_{1N}) is measured at environment temperature 20° C. If the environment temperature is higher or the temperature of gearbox surface exceeds 90° C, please lower input speed (n_1).



Glossary

Max Input Speed (n_{1B}) [rpm]

It is applied to cyclic operation (S5). Max. input speed is measured at environment temperature 20° C. If the environment temperature is higher or the temperature of gearbox surface exceeds 90° C, please lower input speed (n_1).

Speed (n) [rpm]

Two speeds are of relevance when selecting a gearbox: the maximum speed and the nominal speed at the input. The maximum permissible speed n_{1B} must not be exceeded because it serves as the basis at cyclic operation. The nominal speed n_{1N} must not be exceeded at continuous operation. The housing temperature limits the nominal speed, which must not exceed 90° C. The nominal input speed specified in the catalogue applies to an ambient temperature of 20° C. As can be seen in the diagram below, the temperature limit is reached more quickly in the presence of an elevated outside temperature. In other words, the nominal input speed must be reduced if the ambient temperature is high. The values applicable to your gearbox are available from LIMING on request.

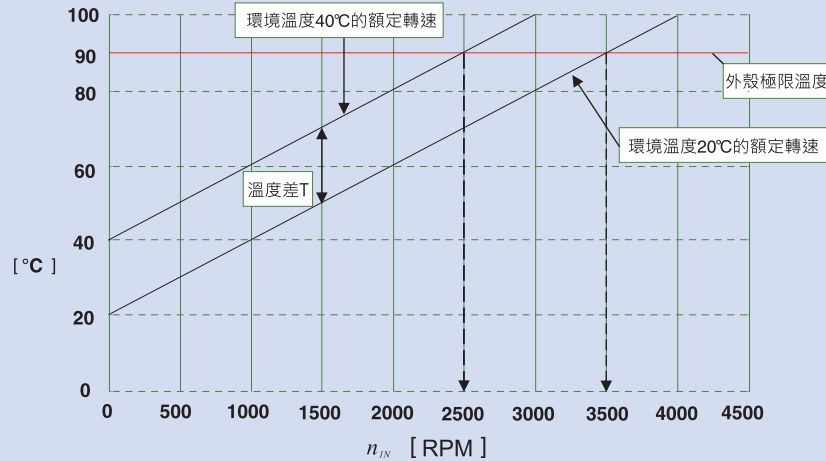

Glossary

Nominal torque (Rated Output Torque) (T_{2N}) [Nm]

The nominal torque T_{2N} is the torque continuously transmitted by a gearbox during a long period of time, i.e. in continuous operation (without wear).

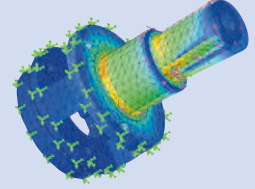

CAE

AE Analysis

Emergency Stop Torque (Max. Output Torque) (T_{2NOT}) [Nm]

The emergency stop torque T_{2NOT} is the maximum permissible torque at the gearbox output end and must not be reached more than 1000 times during the service life of the gearbox. It must never be exceeded to prevent inside parts from damage. LIMING SERVOBOX $T_{2NOT} = 3 \cdot T_{2B}$ (3 times of rated output torque)

Acceleration Torque (T_{2B}) [Nm]

The acceleration torque T_{2B} is the maximum permissible torque that can briefly be transmitted at the gearbox output end under the duty cycle $< 1000/h$ cycles. For $> 1000/h$ cycles, the impact factor must be taken into account. T_{2B} is the max. parameter in cyclic operation. Application acceleration torque (T_{2b}) shall be smaller than T_{2B} ; otherwise the gearbox service life will be reduced.

No Load Running Torque (T_{012}) [Nm]

The no load running torque is the torque which must be applied to a gearbox in order to overcome the internal friction; it is therefore considered lost torque.

Back Driving Torque [Nm]

The back driving torque is the minimum torque to start the rotation from the output side of gearbox. A larger size or a higher ratio gearbox requires greater back driving torque.



Glossary

Average Service Life [h]

Average service life is the working time of gearbox running at rated loading and nominal input speed at cyclic operation.

The service life is not a guarantee of the actual service life of the gear reducer. It is an average calculated life derived from industry formulas (*), and other factors such as running test results, CAE (Computer Aided Engineering) software and so on. These factors take into consideration the metal composition, heat treatment, the design of the gearing and bearings, as well as calculated loads. Service life calculations are not based on actual field conditions or applications, and do not represent a guarantee with respect to expected life, performance, or other characteristics of gear reducer in any given application or use. The actual service life could vary substantially from the nominal service life.

*: Industry formula Refer to the following standardization organization
GB/T 3480-1997 , ISO 6336-1~6336-3:1996

ISO: International Organization for Standardization
GB: Guobiao standards (Chinese National Standards)
DIN: Deutsches Institut für Normung : (German Institute for Standardization)
AGMA: American Gear Manufacturers Association
JIS: Japanese Standards Association

Axial Force (F_{2A}) [N]

The axial force F_{2A} acting on a gearbox runs parallel to its output shaft. The force runs perpendicular to its output shaft. It may be applied with axial offset via a lever arm y_2 under certain circumstances, in which case it also generates a bending moment. If the axial force exceeds the permissible catalogue values, additional design features (e.g. couplings) must be implemented to absorb these forces.



Glossary

Radial Force (F_{2R}) [N]

The radial force is the force acting at right angles to axial force. It acts perpendicular to the axial force and can assume an axial distance of (d) in relation to the shaft end, which acts as a lever arm. The radial force produces a bending moment.

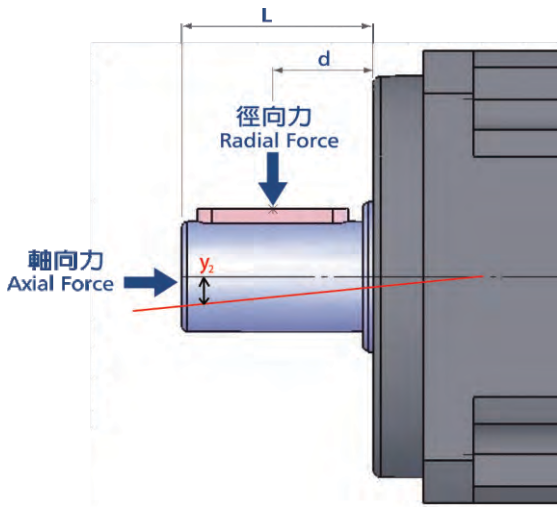

The gearbox will bear radial force while its output shaft connected with transmission machinery, such as chain pulley. The O.H.L. formula of radial force is as below :

$$OHL = \frac{T \cdot s \cdot f \cdot p}{R}$$

T = Torque of transmission machinery

s = Service factor

f = Driven Coefficient

R = Radius of pulley or chain wheel

p = Position Factor: loading position less than d , $p=1$

loading position larger than d , $p=1.5$

(s) Service factor table

Loading classification	Running per Day			
	0.50 hr	2 hr	8-10 hr	10-24 hr
Uniform	0.80	0.90	1.00	1.25
Medium shock	0.90	1.00	1.25	1.50
Heavy shock	1.00	1.25	1.50	1.75

Driven Coefficient (f)

Driving mode	(f)
Chain pulley	1.00
Gear	1.25
V-belt	1.50
Flat-belt	2.50

- CW/CCW operation or start-up/stop reaches 10 times or more within 1 hour, please multiply by 1.2.



Glossary

Permitted Radial Force (F_{2rB}) [N]

The maximum allowed radial force in the 1/2 position of output shaft in the condition of output speed 100 RPM. This value is decreasing when the running speed is increasing.

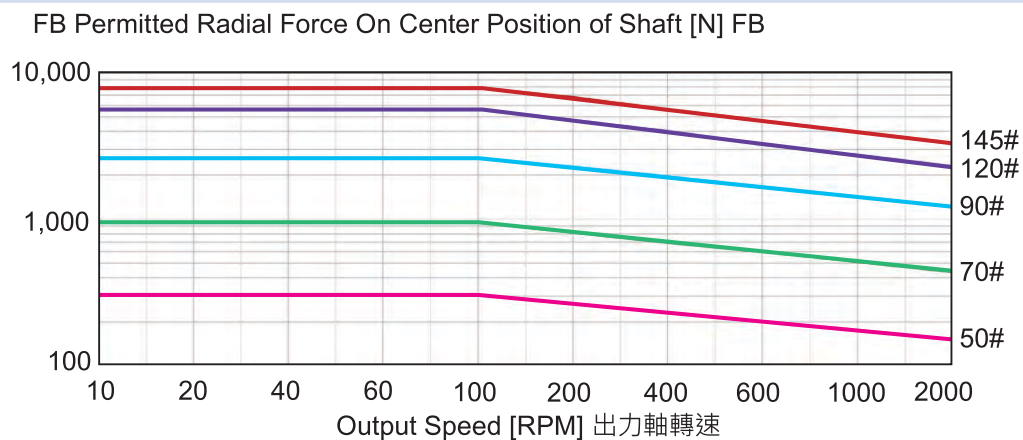

Permitted Axial Force (F_{2aB}) [N]

The maximum allowed axial force in the condition of output speed 100 RPM.

Transmission efficiency η [%]

Efficiency (η) is the ratio of output power to input power. Power lost through friction reduces efficiency to less than 1 or 100%.

$$\eta = \frac{P_{out}}{P_{in}} = \frac{P_{in} - P_{lost}}{P_{in}}$$



Glossary

Noise Level [dB]

The operating noise specified in our catalog relates to gearboxes with the ratio $i=10$ or $i=100$ (2 stage) at input speed 3,000 rpm and no loading running. Noise level is measured at 1M distance from the gearbox. Higher speed results to higher noise level; higher loading results to higher noise level.

Mass moment of inertia (J) [Kg.cm²]

The mass moment of inertia J is a measurement of the effort applied by an object to maintain its momentary condition (at rest or moving).

Rate of mass moment of inertia (λ)

The ratio of mass moment of inertia λ is the ratio of external inertia (application side) to internal inertia (motor and gearbox). It is an important parameter determining the controllability of an application. Accurate control of dynamic processes becomes more difficult with differing mass moments of inertia and as λ becomes greater. LIMING recommends that a guideline value of $\lambda < 5$ is maintained. A gearbox reduces the external mass moment of inertia by a factor of $1 / i^2$.

Simple applications ≤ 10

Dynamic applications ≤ 5

Highly dynamic applications ≤ 1

Torsional Backlash (j_t) [arcmin]

Torsional backlash j_t is the maximum angle of torsion of the output shaft in relation to the input. Torsional backlash is measured with the input shaft locked. The output is then loaded with a defined test torque (2% rated output torque) in order to overcome the internal gearhead friction. The main factor affecting torsional backlash is the face clearance between the gear teeth.

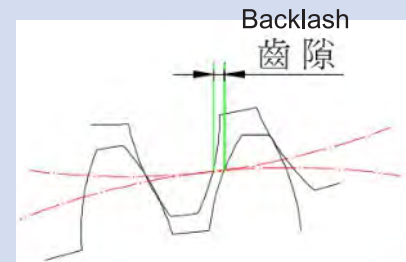

Glossary

Angular minute [Arcmin]

A degree is subdivided into 60 angular minutes (= 60 arcmin = 60'). In other words, if the torsional backlash is specified as 1 arcmin, for example, the output can be turned $1/60^\circ$. The repercussions for the actual application are determined by the arc length.

EX: A pinion with a radius $r = 500$ mm on a gearhead with standard torsional backlash $j_t = 3'$ can be turned $b = 0.44$ mm.

$$b = \frac{2 \cdot \pi \cdot r \cdot j_t}{21600}$$

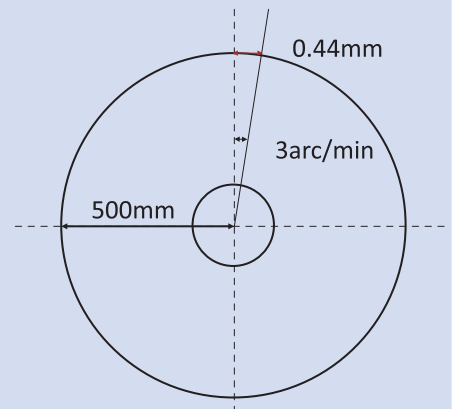

Hysteresis Curve

The hysteresis is measured to determine the torsional rigidity of a gearbox. The result of this measurement is known as the hysteresis curve. If the input shaft is locked, the gearhead is loaded with a torque that increases continuously up to T_{2B} and is then relieved at the output in both directions. The torsional angle is plotted against the torque. This yields a closed curve from which the torsional backlash and torsional rigidity can be calculated.

$$C_{t21} = \frac{\Delta T}{\Delta \phi}$$

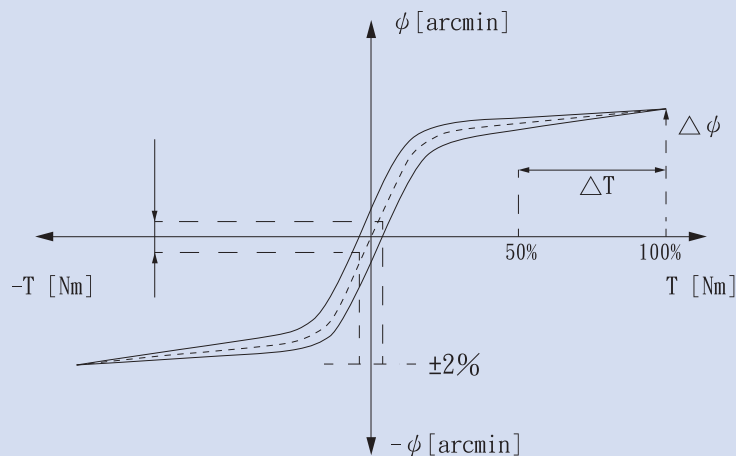

Glossary

Torsional rigidity (C_{t21}) [Nm/Arcmin]

Torsional rigidity is defined as the quotient of applied torque and generated torsion angle.

$$C_{t21} = \frac{\Delta T}{\Delta \phi}$$

It consequently shows the torque required to turn the output shaft by one angular minute. The torsional rigidity can be determined from the hysteresis curve. Only the area between 50% and 100% of T_{2B} is considered because this area of the curve profile can be considered linear.

Operating modes

(continuous operation S1 and cyclic operation S5)

When selecting a gearbox, it is important to consider whether the motion profile is characterized by frequent acceleration and deceleration phases in cyclic operation (S5) as well as pauses, or whether it is designed for continuous operation (S1), i.e. with long phases of constant motion.

Continuous operation (S1)

Continuous operation is defined by the duty cycle. If the duty cycle is greater than 60% or longer than 20 minutes, this qualifies as continuous operation.

Cyclic operation (S5)

Cyclic operation is defined by the duty cycle. If the duty cycle is less than 60% and shorter than 20 minutes, it qualified as cyclic operation.



Glossary

Duty cycle (ED)

The duty cycle ED is determined by one cycle. The times for acceleration (t_a), constant travel if applicable (t_c) and deceleration (t_d) combined yield the duty cycle in minutes. The duty cycle is expressed as a percentage with inclusion of the pause time t_p .

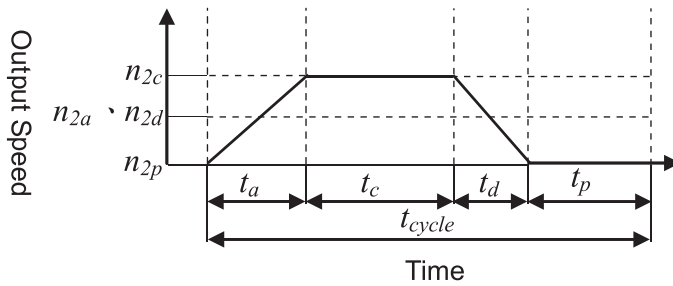

$$ED = \frac{t_a + t_c + t_d}{t_{cycle}}, t_{work} = t_a + t_c + t_d$$

t_a Acceleration , t_c Constant ,

t_d Deceleration , t_p Pause

Stage

The sun gear and planetary gear forms an independent speed reduction gear system. If there is only one gear system in the gear reducer, it is defined as one stage transmission. In order to achieve higher speed reduction ratio, multiple stages transmission is required. LIMING's standard gear reducers are classified into one stage and two-stage transmission. Speed reduction ratio range is from 3 to 100. The modular construction combined with multiple stages transmission allows speed reduction ratio 100~100,000 and over.



Glossary

Degree of protection (IP)

The protective class IP65 sealed design avoids leakage problem.

The various degrees of protection are defined in IEC 60529 "Degrees of protection offered by enclosure (IP code)". The IP degree of protection (IP stands for International Protection) is represented by two digits. The first digit indicates the protection against the ingress of impurities and the second the protection against the ingress of water.

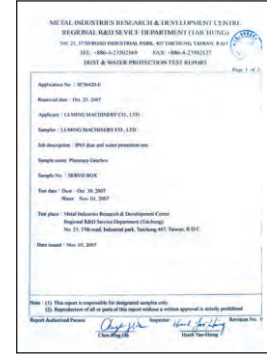

● IP65 Test Report by Metal Industries & Development Center.

Protection against contact and against solid foreign objects.		Protection against ingress of water.	
1st numeral	Description	2nd numeral	Description
0	Non-protected	0	Non-protected
1	Protected against solid foreign objects of >50mm ϕ	1	Protected against vertically falling water drops
2	Protected against solid foreign objects of >12.5mm ϕ	2	Protected against vertically falling water drops when enclosure tilted up to 15°
3	Protected against solid foreign objects of >2.5mm ϕ	3	Protected against spraying water when enclosure tilted up to 60°
4	Protected against solid foreign objects of >1.0mm ϕ	4	Protected against splashing water
5	Protected against ingress of dust (dust-protected)	5	Protected against water jets
6	Protected against ingress of dust by underpressure (dust-tight)	6	Protected against powerful water jets
		7	Protected against the effects of temporary immersion in water
		8	Protected against the effects of continuous immersion in water



Glossary

Operating Temperature

The Operating Temperature indicates the allowable temperature of gearbox at continuous and cyclic operation. SERVOBOX series work in $-25^{\circ}\text{C} \sim +90^{\circ}\text{C}$.

Consider working temperature, ambient temperature should be in $-25^{\circ}\text{C} \sim +45^{\circ}\text{C}$.

Lubrication

It's no essential to replace lubricant during the service life. Lubrication of standard products uses synthetic grease (0#). It depends on the application, there are other grease available.

Collet Clamping

The Collet Clamping ensure a frictional between motor shaft and gearbox. It has passed dynamical balance analysis to assure concentricity and no backlash at high input speed operation.

Bushing

If the motor shaft diameter is smaller than the input bore of gearbox, a bushing is used to compensate the difference in diameter.



Glossary

Design of connecting plate

Design of connecting plate is suitable for various servo motors or others, and also easy for installation. General dimension is shown on the catalogue. Please find other dimensions from our website.



參數值 Value	單位 Unit
輸出功率 Output Power	0.5 W
額定力矩 Rated Torque	1.39 NM
最大力矩 Max. Torque	4.77 NM
額定轉速 Rated Speed	3000 RPM
最大轉速 Max. Speed	3000 RPM
轉動慣量 Inertia	6.8 kg/cm ²
軸徑 Shaft Dia.	24 mm
外徑 Diameter	130 mm
凸緣	110 mm
PCD	145 mm

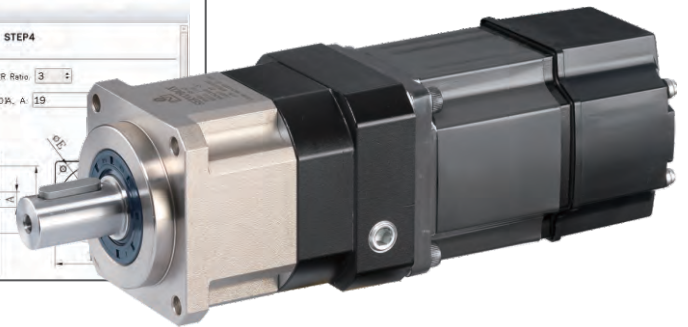

Rotation Directions

1-Stage Planetary Reducer

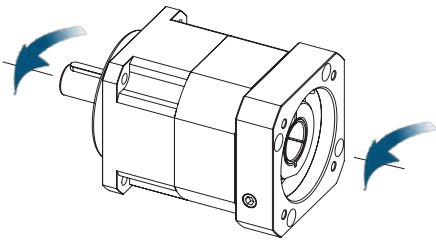

1-Stage Spiral Bevel Gear & Planetary Reducer

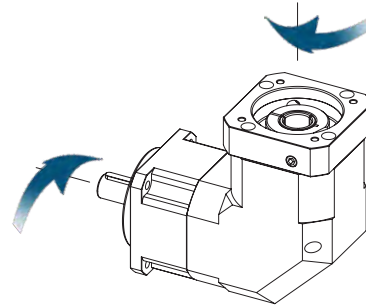

2-Stage Planetary Reducer

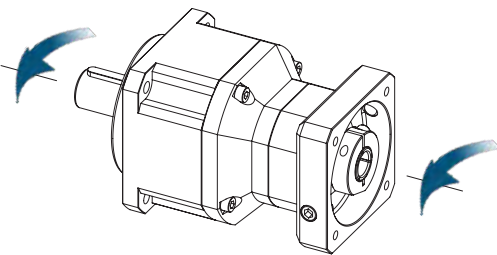

2-Stage Spiral Bevel Gear & Planetary Reducer

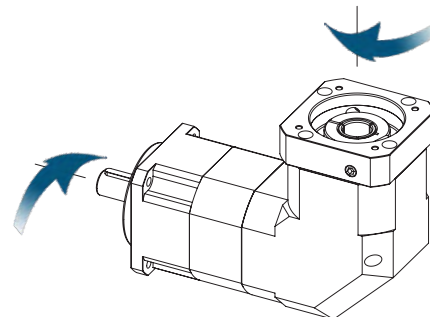

3-Stage Planetary Reducer

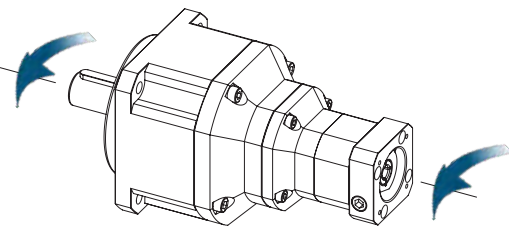

1-Stage Hypoid Gear & Planetary Reducer

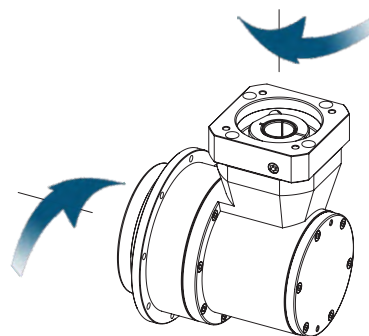

1. Calculate Ratio i (Eq.1)
2. Calculate mean output torque T_{2m} (Eq.2)
Mean output torque $T_{2m} < \text{Nominal output torque } T_{2N}$
3. To determine Operation mode (S1 或 S5)
S5: ED < 60%
S5: $t_{\text{work}} < 20\text{min}$ (Eq.3)
4. If operation mode is (S5)
then calculate the Max. Acceleration Torque $T_{2\text{max}}$ (Eq.4)
Max acceleration torque $T_{2\text{max}} < \text{acceleration torque } T_{2B}$
5. Calculate the Mean Output speed n_{2m}
and the Nominal Output speed n_{2N} of Gearbox (Eq.5)
 $n_{2m} < n_{2N}$
6. Calculate the mean radial force F_{2rm} (Eq.6)
mean radial force $F_{2rm} < \text{Max. radial force } F_{2rB}$
7. Calculate the mean Axial force F_{2am} (Eq.7)
mean axial force $F_{2am} < \text{Max. axial force } F_{2aB}$
8. Select the Required Backlash and Shaft Option
9. Order your LIMING Gearbox

Recommended (for S5 Cyclic Operation)

The general design is given for

$$\frac{J_L}{i^2} \leq 4 \cdot J_m$$

The optimal design is given for

$$\frac{J_L}{i^2} \cong J_m$$

Where J_L is Load Inertia and J_m is Motor Inertia.

T_{2N} please reference catalog 「Rated Output Torque」

F_{2rB} please reference catalog 「Max. Radial Force」

$$\text{Eq.1} \quad i \cong \frac{n_m}{n_{\text{work}}}$$

n_m is output speed of the motor, n_{work} is working speed

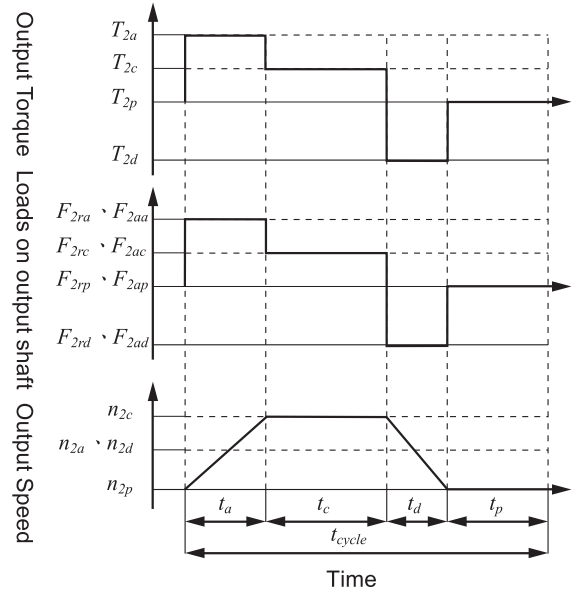

$$\text{Eq.2} \quad T_{2m} = \sqrt[3]{\frac{n_{2a} \cdot t_a \cdot T_{2a}^3 + n_{2c} \cdot t_c \cdot T_{2c}^3 + n_{2d} \cdot t_d \cdot T_{2d}^3}{n_{2a} \cdot t_a + n_{2c} \cdot t_c + n_{2d} \cdot t_d}}$$

$$\text{Eq.3} \quad ED = \frac{t_a + t_c + t_d}{t_{\text{cycle}}}, t_{\text{work}} = t_a + t_c + t_d$$

t_a is the time for acceleration, t_c is constant travel,
 t_d is the time for deceleration and t_p is the time for pause.

$$\text{Eq.4} \quad T_{2\text{max}} = T_{mB} \cdot i \cdot k_s \cdot \eta$$

T_{mB} is the Max. output torque of the motor and η is the efficiency of the gearbox

K_s service factor	
K_s	No. of Cycles / hr
1.0	0 ~ 1,000
1.1	1,000 ~ 1,500
1.3	1,500 ~ 2,000
1.6	2,000 ~ 3,000
1.8	3,000 ~ 5,000

$$\text{Eq.5} \quad n_{2a} = n_{2d} = \frac{n_{2c}}{2}$$

$$n_{2m} = \frac{n_{2a} \cdot t_a + n_{2c} \cdot t_c + n_{2d} \cdot t_d}{t_a + t_c + t_d}$$

$$n_{2N} = \frac{n_{1N}}{i}$$

$$\text{Eq.6} \quad F_{2rm} = \sqrt[3]{\frac{n_{2a} \cdot t_a \cdot F_{2ra}^3 + n_{2c} \cdot t_c \cdot F_{2rc}^3 + n_{2d} \cdot t_d \cdot F_{2rd}^3}{n_{2a} \cdot t_a + n_{2c} \cdot t_c + n_{2d} \cdot t_d}}$$

$$\text{Eq.7} \quad F_{2am} = \sqrt[3]{\frac{n_{2a} \cdot t_a \cdot F_{2aa}^3 + n_{2c} \cdot t_c \cdot F_{2ac}^3 + n_{2d} \cdot t_d \cdot F_{2ad}^3}{n_{2a} \cdot t_a + n_{2c} \cdot t_c + n_{2d} \cdot t_d}}$$



Installation & Critical Applications

Critical applications

For other mounting positions and/or particular input speeds, please contact our technical person.

It is also necessary to take due consideration of and carefully assess the following applications by calling our Technical Service:

- The maximum input speed exceeds nominal input speed.
- The maximum output torque exceeds rated output torque.
- Use in services that could be hazardous for people if the reduction unit fails.
- Applications with especially high inertia.
- Use as a lifting winch.
- Applications with high dynamic strain on the case of the reduction unit.
- Ambient temperature under -25°C or over 45°C .
- Use in chemically aggressive environments.
- Use in a salty environment.
- Use in radioactive environments.
- Use in environments pressures other than atmospheric pressure.

Avoid applications where even partial immersion of the reduction unit is required.

The maximum torque (*) that the gear reducer can support must not exceed three times the nominal torque .

(*) intended for momentary overloads due to starting at full load, braking, shocks or other causes, particularly those that are dynamic.



Installation & Critical Applications

Installation

To install the reduction unit, it is necessary to note the following recommendations:

- The mounting on the machine must be stable to avoid any vibration.
- Check the correct direction of rotation of the reduction unit output shaft before fitting the unit to the machine.
- In the case of particularly lengthy periods of storage (4/6 months), if the oil seal is not immersed in the lubricant inside the unit, it is recommended to change it since the rubber could stick to the shaft or may even have lost the elasticity it needs to function properly.
- Whenever possible, protect the reduction unit against solar radiation and bad weather.
- Ensure the motor cools correctly by assuring good passage of air from the fan side.
- In the case of ambient temperatures $< -25^{\circ} \text{C}$ or $> +45^{\circ} \text{C}$ call the Technical Services.
- The various parts (pulleys, gear wheels, couplings, shafts, etc.) must be mounted on the solid or hollow shafts using special threaded holes or other systems that anyhow ensure correct operation without risking damage to the bearings or external parts of the units. Lubricate the surfaces in contact to avoid seizure or oxidation.
- Starting must take place gradually, without immediately applying the maximum load.
- When there are parts, objects or materials under the motor drive that can be damaged by even limited spillage of oil, special protection should be fitted.



Applications

○ Linear Action

● Ball Screw

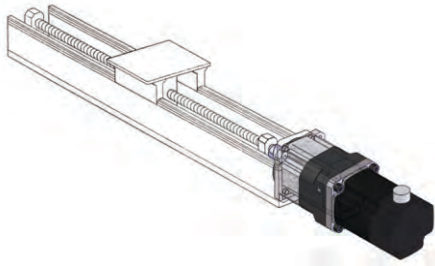

● Rack

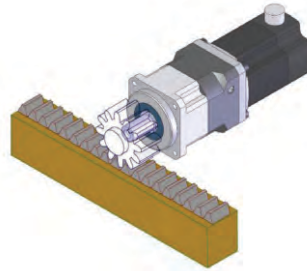

● Roller / Belt

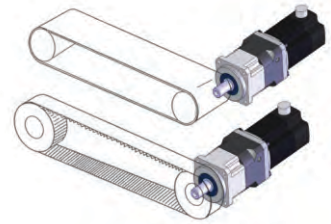

○ Rotary Action

● Index

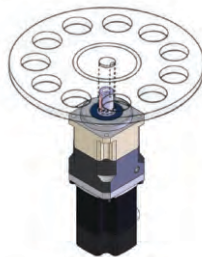

○ Others

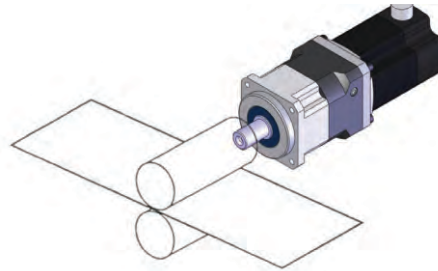

● Robot

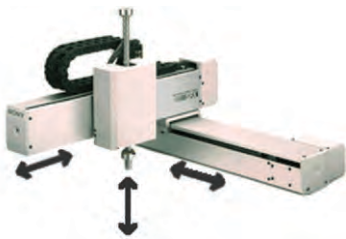

● Printing Machine



● Conveyor

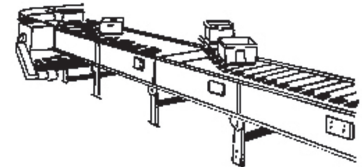

● Working Table

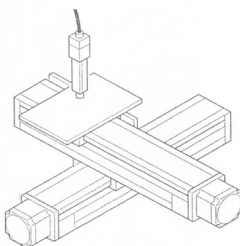

● CNC Spindle

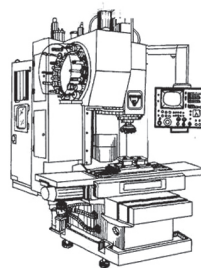

● Index

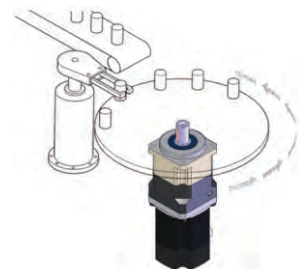

Planetary Gearbox and Motor Mounting Instructions



Confirm the motor, and gearbox size.
Clean up the mounting surface.

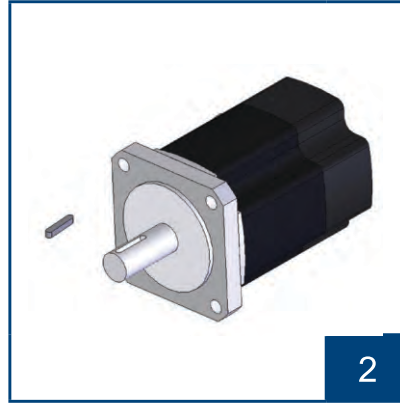

Remove the motor key if the diameter
of motor shaft is under $\varphi 35$.

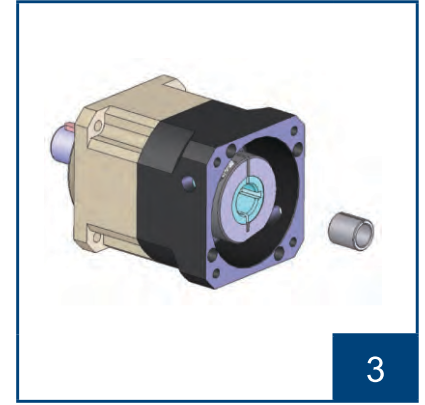

Check motor shaft size and insert
bushing into input bore if necessary.

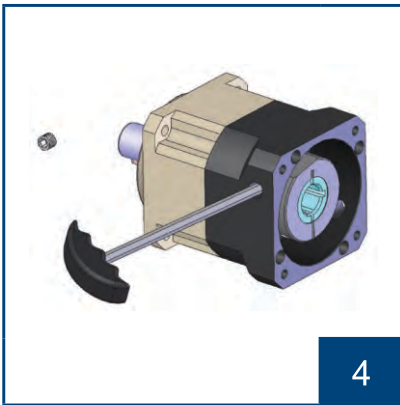

Remove the plug on the adapter plate.
Rotate the set collar till the bolt is line
up.



Put the motor into the gearbox vertically.

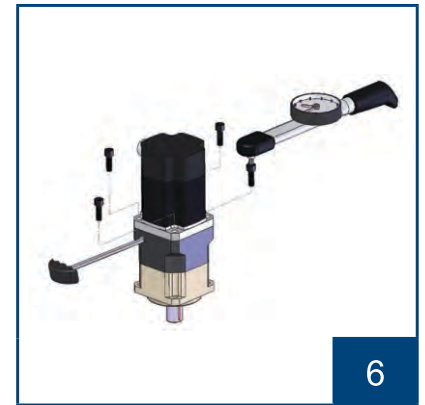

Tighten the mounting bolt in 1~4 order
with torque wrench.

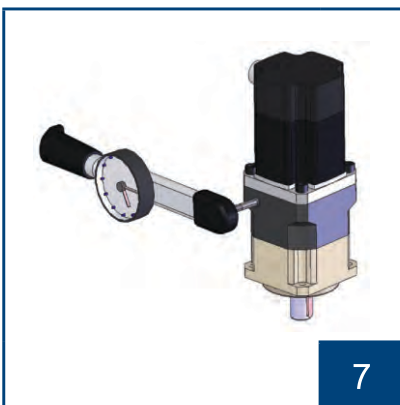

Tighten the set collar bolt with torque
wrench.

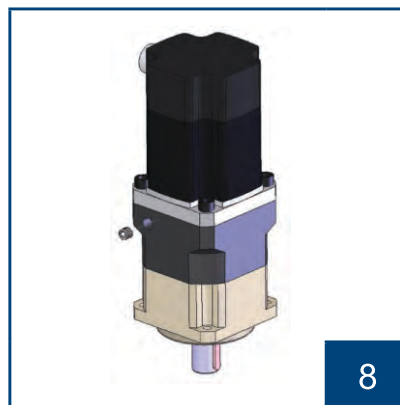

Tighten back the screw plug.

1. To be sure to tighten motor first and
then to tighten the set collar on
motor shaft.

2. Please assembly in order according
to above steps, especially for step 6
and step 7.



Inquiry Information

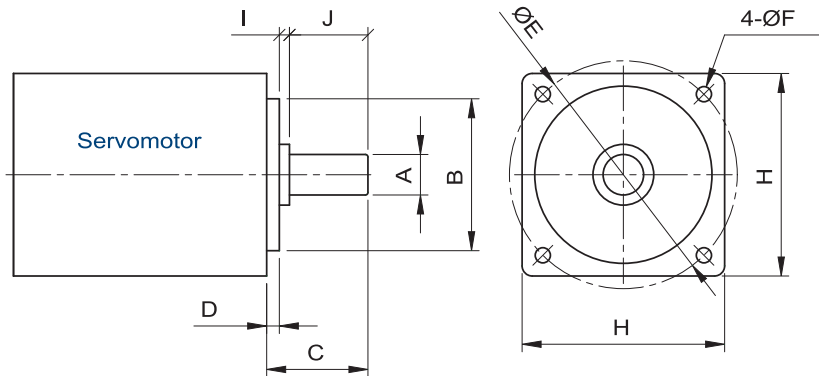

A	B	C	D	E	F	H	I	J

<input type="text"/>	—	<input type="text"/>	—	<input type="text"/>	<input type="text"/>	—	<input type="text"/>	—	<input type="text"/>
Type		Model		Ratio	Output Shaft Keyway		Backlash Class		MOTOR NO.

General Notices:

- ◆ Type, model and horsepower
- ◆ Speed ratio or R.P.M of output shaft
- ◆ Method of connection and loading
- ◆ Quantity and applied mechanism
- ◆ Input connection method and input speed
- ◆ Motor band Model no or frame & motor shaft dimension

