

TITLE 3D OBC 15 16 B-300

PART NO OBC 15 16 B-300

REVISION 01

DESIGNER OBC

ENGINEER OBC

NOTES

برای مشاهده فایل سه بعدی از

نرم افزار adobe reader

استفاده نمایید

OBC 15*16 B

مدول خطی با سیستم حرکت بال اسکرو و لینیرگاید
ابعاد داخل جدول بر اساس کورس ۳۰۰ میلی متر می باشد

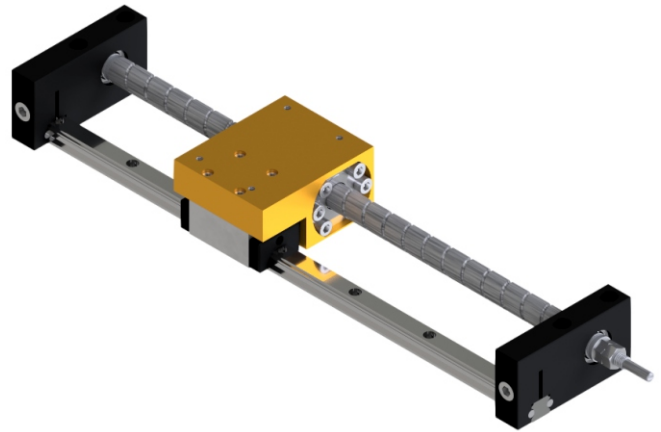
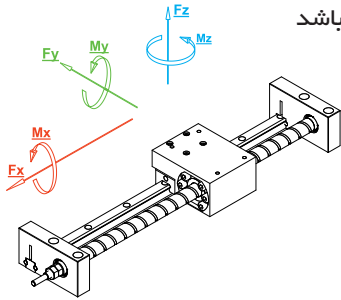

Load	Static	Single blocks
■ F _x	(N)	
■ F _y	(N)	
■ F _z	(N)	
Moment		
■ M _x	(Nm)	
■ M _y	(Nm)	
■ M _z	(Nm)	

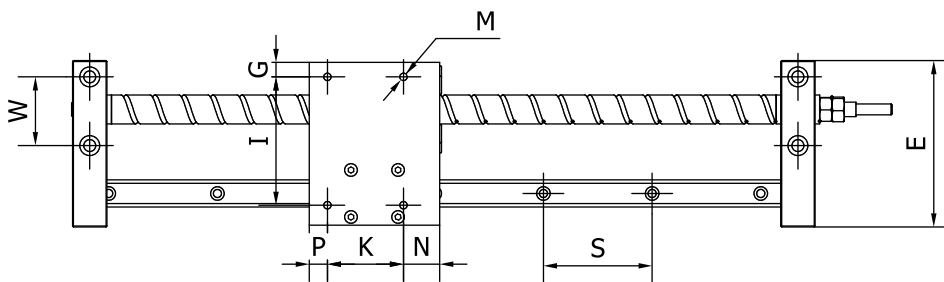
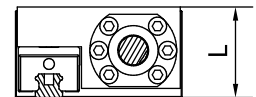
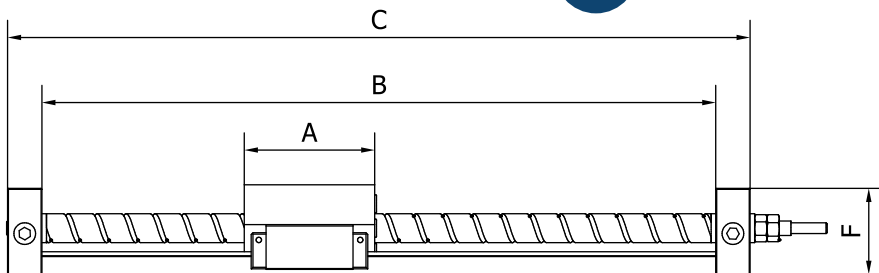

Unit : mm

کد کالا	A	B	C	F	L	E	S	W	M	G	I	P	K	N
OBC 15*16 B	72	372	410	48	50±1	92	60	38	M5x4	8	71	10	42	20
Body	—						Max Length				800 mm			
Max Speed	50 mm/s						Linear Rail				15			
Pitch	16 mm						Linear Block				TRH-15			
Ball Screw	Ø16-05						Positioning Accuracy				0.01 mm			

