

## ARFM

موتور های سری 4T (طول چنجر) در توان های 3-12 کیلووات

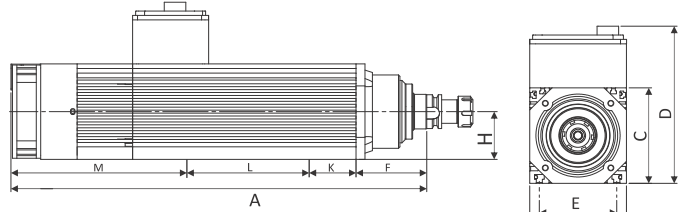

4T  
KARE FANLI  
MINIMIZED FAN



4T

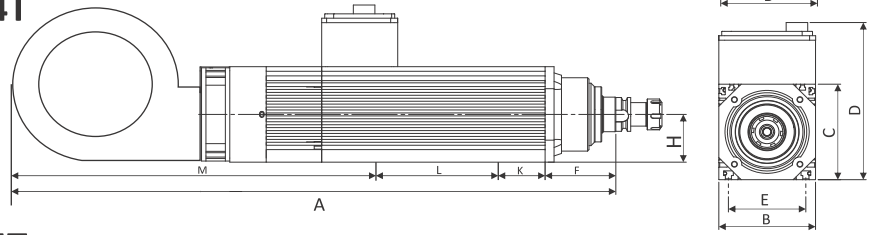

5T

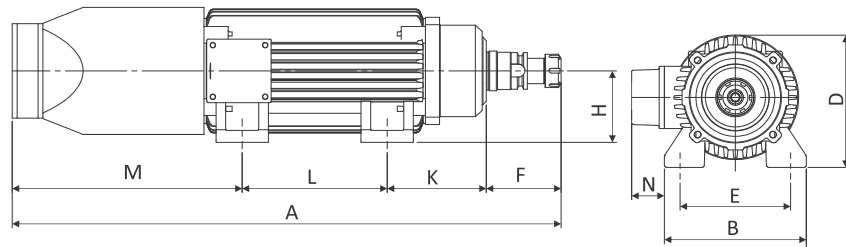

6T

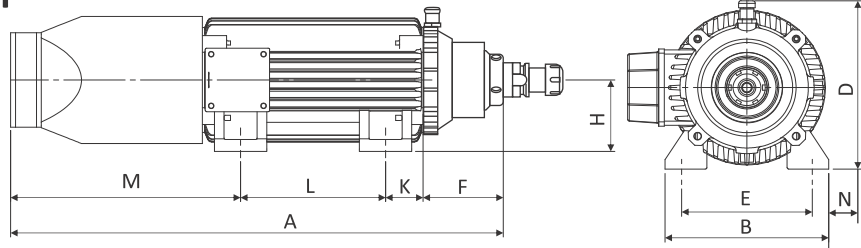

Type	A mm	B mm	C mm	D mm	E mm	F mm	H mm	K mm	L mm	M mm	N mm	
ARFM.4T-S	460	130	130	210	104	95	65	M8 KANAL / SLOT				
ARFM.4T-M	510	130	130	210	104	95	65	M8 KANAL / SLOT				
ARFM.4T-L	560	130	130	210	104	95	65	M8 KANAL / SLOT				
ARFM.5T-L	618	180	-	168	140	105	88	47	180	286	40	
ARFM.6T-L	655	180	-	185	150	115	95	50	20	290	46	
Type	KW/HP		Rpm	HZ	Volt	Ampere	kg	PENS/COLLETS				
ARFM.4T-S2	3 / 4		12000	200	380v.3~	6	21.5	BT 30 ER 25 1-16 mm				
ARFM.4T-S3	4 / 5.5		18000	300	380v.3~	8.2	21.5					
ARFM.4T.M2	4 / 5.5		12000	200	380v.3~	8.2	25.5					
ARFM.4T-M3	5.5 / 7.5		18000	300	380v.3~	12	25.5	BT 30 ER 32 2-20 mm				
ARFM.4T-L2	5.5 / 7.5		12000	200	380v.3~	12	29.5					
ARFM.4T-L3	7.5 / 10		18000	300	380v.3~	15.5	29.5					
ARFM.5T-L1	6 / 8		6000	200	380v.3~	13.8	44					
ARFM.5T-L2	9 / 12		12000	400	380v.3~	18.5	44					
ARFM.6T-L1	9 / 12		6000	200	380v.3~	18.5	54					
ARFM.6T-L2	12.5 / 17		12000	400	380v.3~	26	54					



# ARFM.4K TAKIM DEĞİŞTİRMELİ MOTOR KLEMENS BAĞLANTI ŞEMASI

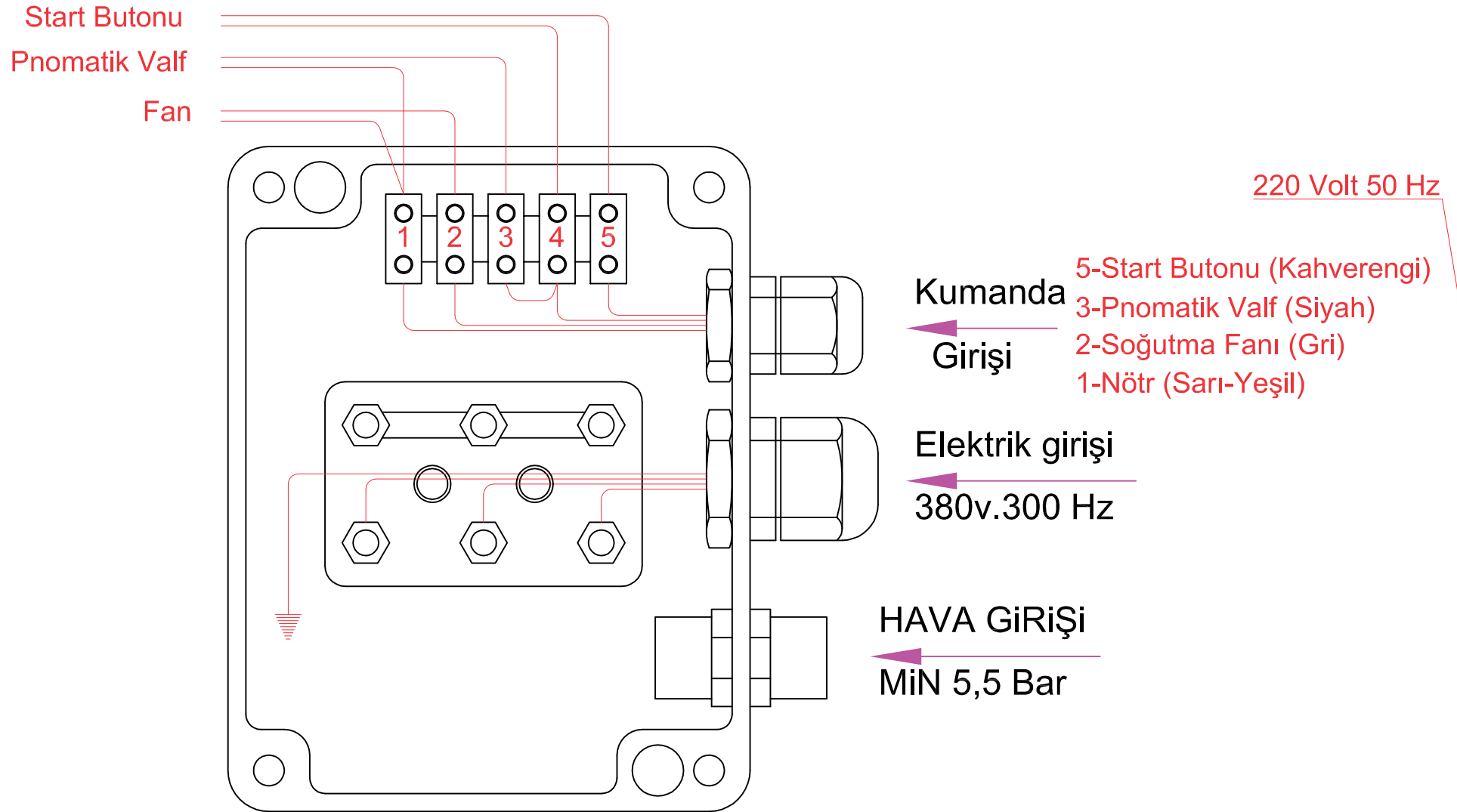

# ARFM.4K AUTOMATIC TOOL CHANGE SPINDLE WIRING DIAGRAM

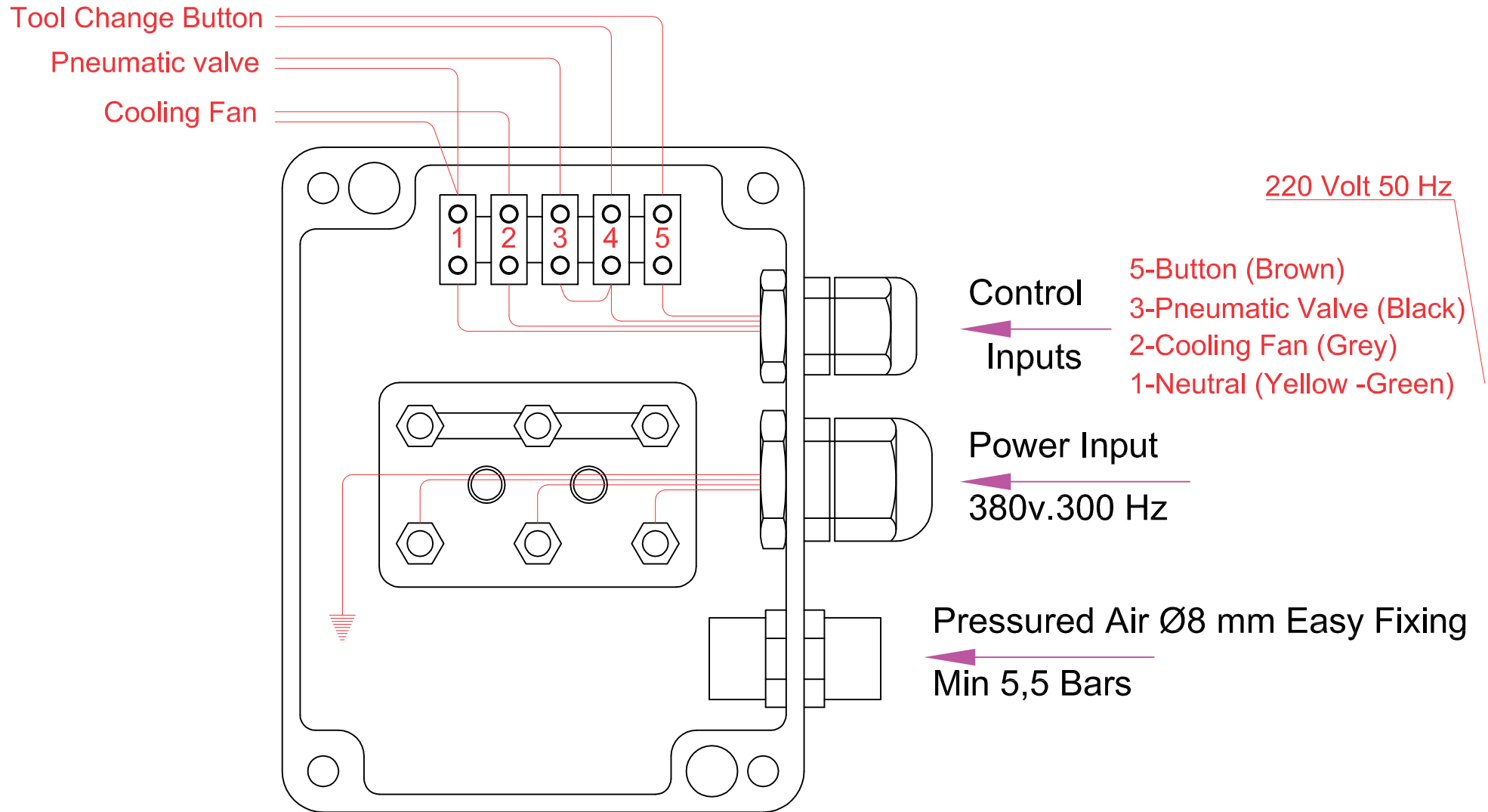

# ARFM.5T-L2 OTOMATİK TAKIM DEĞİŞTİRMELİ (ATC) SPINDLE

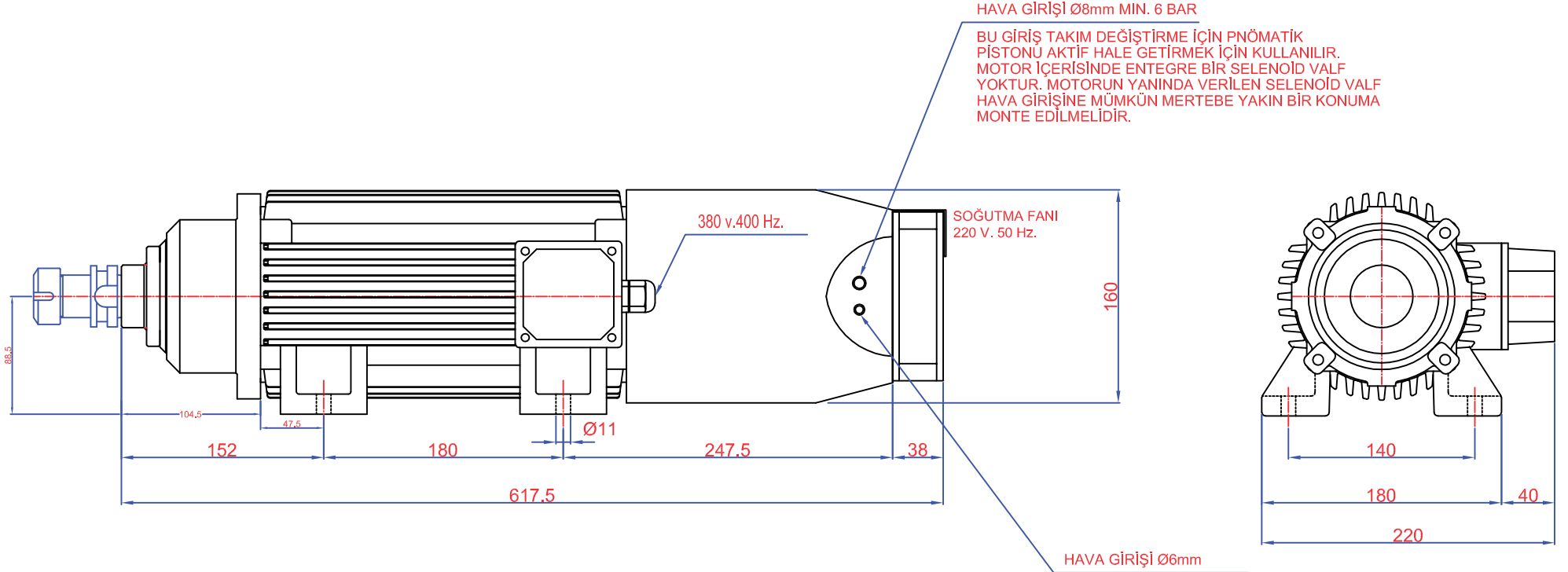

BU GİRİŞ KONİK TEMİZLİĞİ İÇİNDİR. KONİK TEMİZLEME İŞLEMİ SADECE TAKIM DEĞİŞTİRME PİSTONU AKTİFKEN GERÇEKLEŞTİRİLMELİDİR. BURAYA SADECE TAKIM DEĞİŞTİRME PİSTONUNA HAVA VERİLDİĞİNDE HAVA VERİLMELİDİR. AKSİ TAKDİRDE RULMANLARIN ZARAR GÖRME OLASILIĞI VARDIR.

1/1	0	1	0	0	00	C	B
Ölçek	Malzeme Cinsi	Adet	Ağırlık	Malzeme Ebatı	Revizyon No	Hammadde No	Stok No
Çizen	Adı Soyadı	İmza	PARÇA ADI			AREL	
Onay	Ö.TAŞKAN		ARFM.5T-L2 AUTOMATIC TOOL CHANGE SPINDLE				
Tarih	A.ARCAĞ						
	0						

## ARFM.5T-L2 AUTOMATIC TOOL CHANGE SPINDLE (BT30)

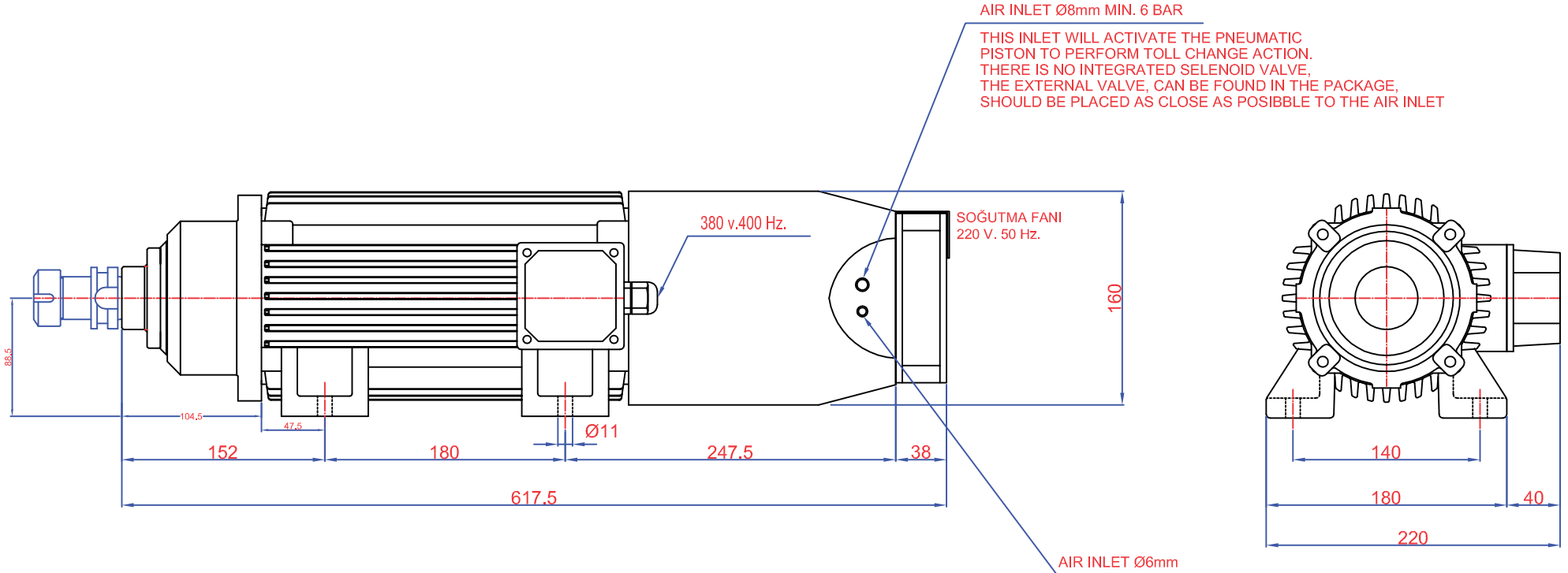

THIS INLET IS FOR CONIC CLEANING, THE PRESURIZED AIR APPLIED HERE WILL GO OUT THROUGH THE CONIC TAPER OF THE SPINDLE IN ORDER TO AVOID DUST CONTAMINATION. THIS INLET SHOULD ONLY BE USED WHEN THE PNEUMATIC PISTON IS PRESURIZED. OTHERWISE DAMAGES ON THE BEARINGS IS POSSIBLE.

1/1	0	1	0	0	00	C	B
Ölçek	Malzeme Cinsi	Adet	Ağırlık	Malzeme Ebatı	Revizyon No	Hammadde No	Stok No
Çizen	Adı Soyadı	İmza	PARÇA ADI			AREL	
Onay	Ö.TAŞKAN		ARFM.5T-L2 AUTOMATIC TOOL				
Tarih	A.ARCAĞ		CHANGE SPINDLE				
	0						

ARFM.6T-L1 OTOMATİK TAKIM DEĞİŞTİRMELİ (ATC) SPINDLE (BT30)  
9 KW 6.000 RPM

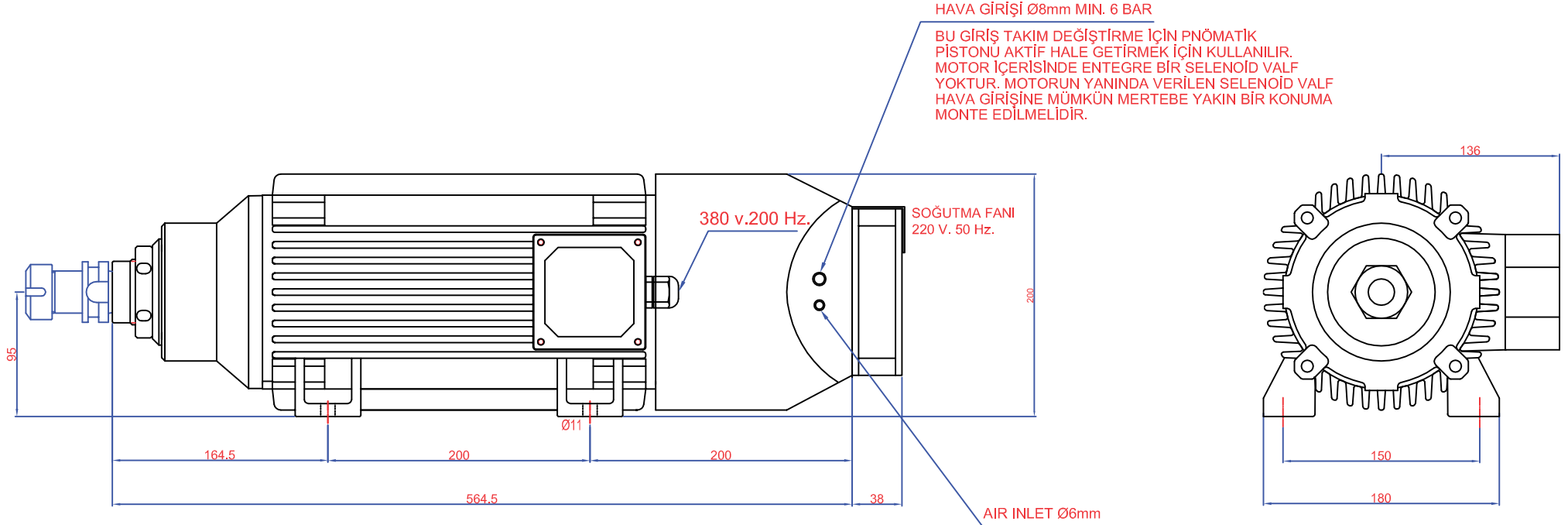

BU GİRİŞ KONİK TEMİZLİĞİ İÇİNDİR. KONİK TEMİZLEME İŞLEMİ SADECE TAKIM DEĞİŞTİRME PİSTONU AKTİFKEN GERÇEKLEŞTİRİLMELİDİR. BURAYA SADECE TAKIM DEĞİŞTİRME PİSTONUNA HAVA VERİLDİĞİNDE HAVA VERİLMELİDİR. AKSİ TAKDİRDE RULMANLARIN ZARAR GÖRME OLASILIĞI VARDIR.

1/1	0	1	0	0	00	C	B
Ölçek	Malzeme Cinsi	Adet	Ağırlık	Malzeme Ebatı	Revizyon No	Hammadde No	Stok No
Çizen	Adı Soyadı	İmza	İŞİN ADI			<b>AREL</b>	
Onay	A.ARCAG		ARFM.6T-L1 OTOMATİK TAKIM DEĞİŞTİRMELİ SPINDLE (BT30)				
Tarih	0						

ARFM.6T-L1 AUTOMATIC TOOL CHANGE SPINDLE (BT30)  
9 KW 6.000 RPM

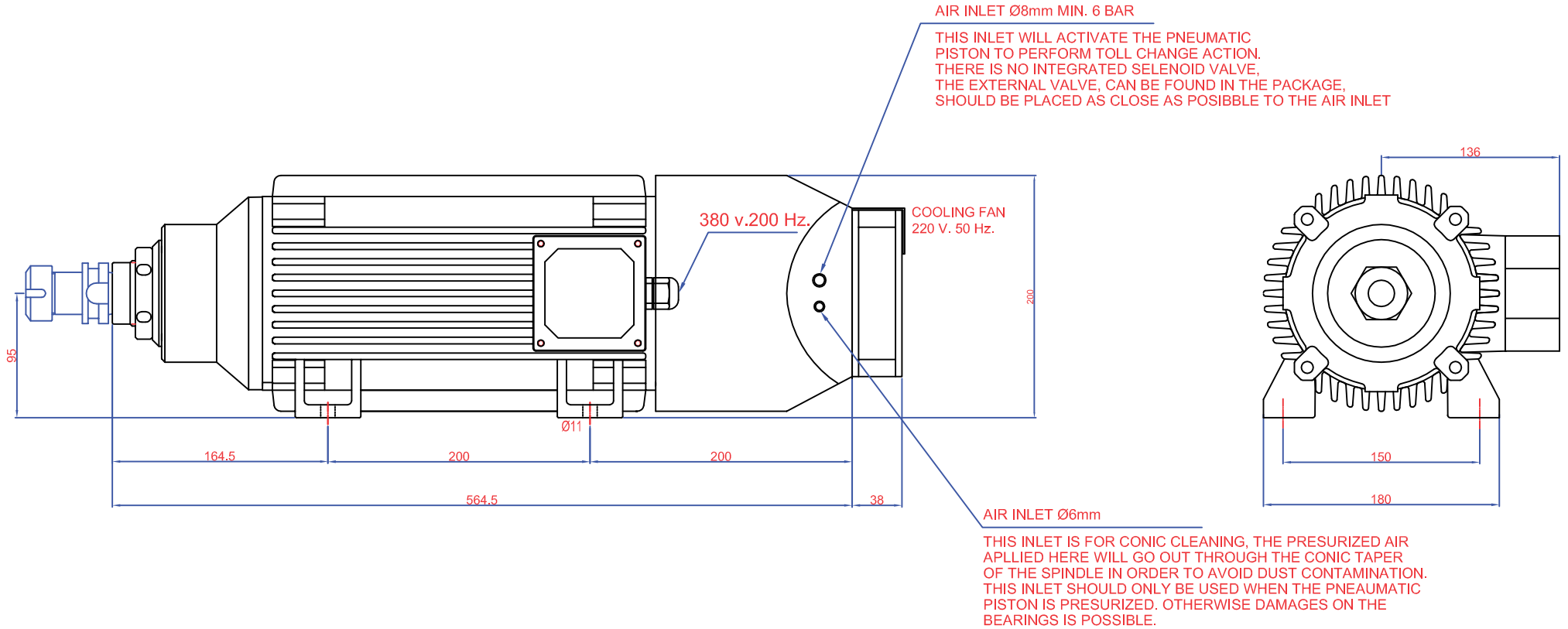

1/1	0	1	0	0	00	C	B
Ölçek	Malzeme Cinsi	Adet	Ağırlık	Malzeme Ebatı	Revizyon No	Hammadde No	Stok No
	Adı Soyadı	İmza	İŞİN ADI			<b>AREL</b>	
Çizen	A.ARCAĞ		ARFM.6T-L1 AUTOMATIC TOOL CHANGE SPINDLE (BT30)				
Onay	A.ARCAĞ						
Tarih	0						