

iES-2320 Integrated Easy Servo

Motor + Drive + Encoder, 20-50VDC, NEMA23, 2.0Nm



Features

- Easy servo control technology to combine advantages of open-loop stepper systems and brushless servo systems
- Closed-loop controls to eliminate lose of steps, stall or movement synchronization
- Integrated compact size for saving mounting space & setup time, and reducing electrical interference
- 1000-line integrated optical incremental encoder for accurate position control
- High starting torque and quick response
- Smooth motor movement with no vibration
- Excellent respond time, quick acceleration, and very high high-speed torque (30% over open-loop)
- Load-dependent dynamic current output from drive to motor to significantly motor heating deduction
- Input voltage from 20 to 50 VDC; 6.0A peak current output from drive to motor
- 2 Nm (285 oz-in) holding torque stepper motor with NEMA 23 frame size installation
- 16 micro step resolution options via DIP switches; or any value from 200-51,200 (increased by 1) via software configuration
- Isolated control inputs of Pulse, Direction and Enable
- No tuning for plug and play setup
- In-position and fault outputs to external motion controllers for complete system controls.
- Over voltage, over-current, and position-error protection

Descriptions

Leadshine s iES-2320 integrated easy servo motor is a NEMA 23 stepper motor integrated with a 1,000-line (4,000 PPR) encoder and an easy servo drive. At very compact size and with all components integrated, the iES-2320 can save mounting space, eliminate encoder connection & motor wiring time, reduce interference, and cut/reduce cable and labor costs.

By adopting Leadshine s latest easy servo control technology, the easy servo drive of the iES-2320 can drive the stepper motor with high staring torque, high precision, smooth movement, and extra low noise at low speed movement with no obvious resonance area. Different from constant-output-current output from a drive to a stepper motor in normal open-loop stepper controls, output current of the iES-2320 is dynamic and changes depending on load condition, same as servo controls. Therefore, it can significantly reduce motor heating and increase motor lifetime. The drive takes step & direction input commands, and is capable of outputting in-position and fault signals back to a motion controller or external devices, for complete system controls.



Descriptions (Continued)

The integrated 1,000-line encoder of the iES-2320 offers the real-time motor shaft position to the drive. Based on that position, the drive can then close the loop between the motor and drive, ensure no step is lost, and eliminate the possibility of stall or loss of movement synchronization which is often found in open-loop stepper systems. By getting rid of torque reservation in open-loop stepper systems, the iES-2320 can significantly improve high speed performance by as much as 30%. In addition, the iES-2320 performs much better in response time and speed acceleration over open-loop step systems.

Compared with brushless servo systems, the iES-2320 has much higher low speed torque, no overshooting & zero settling time, no overshooting, no hunting, and no/little tuning. Significant cost cutting also makes the iES-2320 ideal for the motion control systems in many applications.

Applications

Leadshine's iES-2320 integrated easy servo motor offers an alternative solution to fill the gap between budget open-loop stepper systems, and expensive high performance brushless servo systems. It combines the features of high low-speed torque of open-loop stepper, and closed-loop movements of traditional servo systems. Integration design with motor, drive, and encoder significantly reduces setup time and cut costs of your control systems.

Advanced features over open-loop stepper systems, such as much higher high-speed torque, no loss of movement synchronization, much lower motor heating, no obvious resonance area, etc., make the iES-2320 ideal for upgrading stepper systems to get performance boost for many stepper applications such as CNC routers, CNC laser cutting machines, CNC milling machines, CNC lathes, medical / biotech equipments, lab automation instruments, etc.

Features over traditional brushless servo systems, such as significant lower costs, no hunting, no overshooting, easy setup, etc., make the iES-2320 ideal products in many traditional servo applications such as short distance movement boding type machines and vision applications. Its natural feature of high low-speed torque makes the iES-2320 a perfect product for replacing many high-cost servo applications with gear head speed reduction.

Specifications

Electrical Specifications

Parameter	Min	Typical	Max	Unit
Input Voltage	20	36	50	VDC
Output Current	0	-	6.0(Peak)	A
Pulse Input Frequency	0	200	500	kHz
Pulse Voltage	0	5	24	V
Logic Signal Current	7	10	16	mA
Isolation Resistance	100	-	-	M!



Operating Environment

Cooling	Natural Cooling or Forced cooling	
Operating Environment	Environment	Avoid dust, oil fog and corrosive gases
	Ambient Temperature	0°C — 40°C (32°F — 104°F)
	Humidity	40%RH — 90%RH
	Operating Temperature (Heat Sink)	70°C (158°F) Max
Storage Temperature	-20°C — 65°C (-4°F — 149°F)	

Motor Specifications

Part Number	Holding Torque	Motor Length (L)	Motor Inductance	Weight
iES-2320	2.0 Nm	80+/-1mm	1.63mH	1280 g

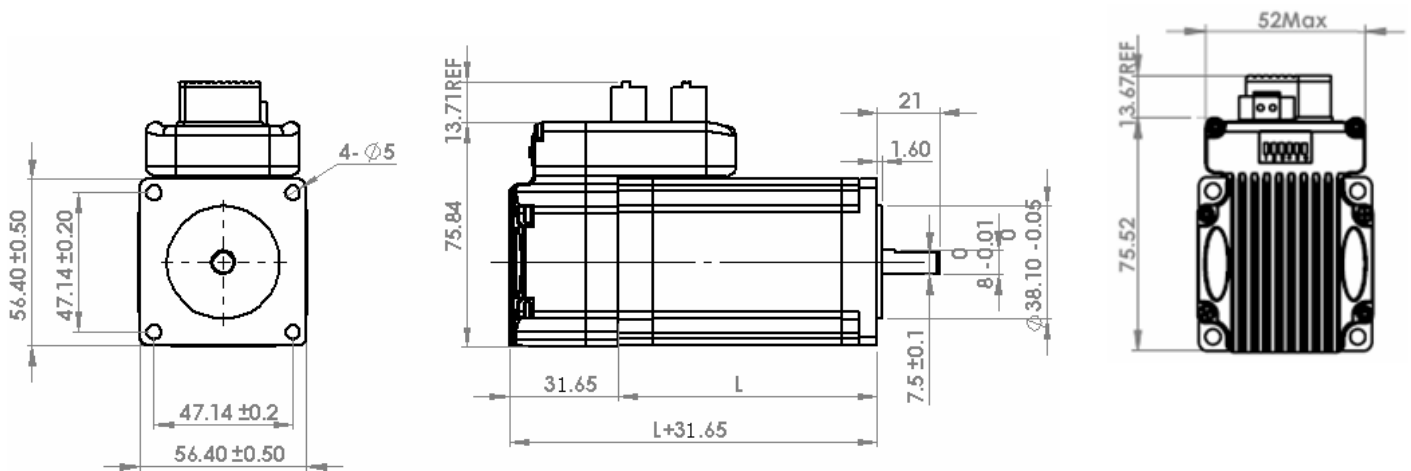

Mechanical Specifications

L = 80+/-1mm, total length = 112+/-1mm



Protection Indications

The green light turns on when iES-2320 is powered on and functions normally. In any case that drive protection is activated, the red LED blinks periodically (in every 4 seconds) to indicate the error type. In each blink, red light is on for 0.2 second and then off for 0.3 second.

Priority	Time(s) of Blink	Sequence wave of red LED	Description
1st	1		Over-current protection activated when peak current is greater than 18A
2nd	2		Over-voltage protection activated when drive working voltage is greater than 60VDC
3rd	7		Position following error activated when position following error limit exceeded the pre-set value (1000 pulses by default, or value set value by a customer)

Connectors and Pin Assignment

Leadshine iES-2320 has three connectors, a connector for control signals connections, a connector for RS232 communication connection, and a connector for power connections.

Control Signal Connector			
Pin	Name	I/O	Description
1	PUL+	I	<u>Pulse signal</u> : In single pulse (pulse/direction) mode, this input represents pulse signal, active at each rising or falling edge (Set by DIP switch S6). In double pulse mode (software configurable), this input represents clockwise (CW) pulse, active both at each high level and low level. 4.5-24V for PUL-HIGH, 0-0.5V for PUL-LOW. For reliable response, pulse width should be longer than 2.5 μ s for 200K MAX input frequency or 1 μ s for 500K MAX input frequency.
2	PUL-	I	
3	DIR+	I	<u>Direction Signal</u> : In single-pulse mode, this signal has low/high voltage levels, representing two directions of motor rotation. In double-pulse mode (software configurable), this signal is counter-clock (CCW) pulse, active both at high level and low level. For reliable motion response, DIR signal should be ahead of PUL signal by 5 μ s at least. 4.5-24V for DIR-HIGH, 0-0.5V for DIR-LOW. Toggle DIP switch SW5 to reverse motion direction.
4	DIR-	I	
5	ENA+	I	<u>Enable signal</u> : This signal is used for enabling/disabling the driver. By default, high level (NPN control signal) for enabling the driver and low level for disabling the driver. It is usually left UNCONNECTED (ENABLED) . Please note that the PNP and Differential control signals are on the contrary, namely Low level for enabling. The active level of ENA signal is software configurable.
6	ENA-	I	



Connectors and Pin Assignment (Continued)

Control Signal Connector			
Pin	Name	I/O	Description
7	PED+	O	<u>In-position Signal</u> : OC output signal, activated when actual motor position reaches to target position. This port can sink or source MAX 20mA current at 24V. By default, the impedance between PED+ and PED- is high in normal operation and changed to low when the target position is reached. The active impedance of in-position signal can be software configurable (See software manual).
8	PED-	O	
9	ALM+	O	<u>Alarm Signal</u> : OC output signal, activated when one of the following protection is activated: over-voltage, over current and position following error. They can sink or source MAX 20mA current at 24V. By default, the impedance between ALM+ and ALM- is low at normal operation and becomes high when any protection is activated. The active impedance of alarm signal is software configurable.
10	ALM-	O	

Power Connector			
Pin	Name	I/O	Description
1	+Vdc	I	Power Supply Input (Positive) 20-45VDC recommended. Please leave reasonable reservation for voltage fluctuation and back-EMF during deceleration.
2	GND	GND	Power Ground (Negative)

RS232 Communication Connector			
Pin	Name	I/O	Description
1	+5V	O	+5V power output (Note: Do not connect it to PC s serial port)
2	TxD	O	RS232 transmit.
3	GND	GND	Ground.
4	RxD	I	RS232 receive.
5	NC	-	Not connected.

DIP Switch Settings

Micro Step Resolution (S1-S4)

Micro step resolution of the iES-2320 can be configured via a 4-bit DIP switch, or Leadshine s tuning software ProTuner. When all bits of the DIP switch are at “ON” positions, the integrated easy servo drive will take the micro step resolution setting set by the software (4000 by default). In this case, a user can re-configure the resolution to any value between 200 and 51, 200 (increased by 1) through software. If any bit of the DIP switch is at “OFF” position, the integrated drive will take micro step revolution setting determined by bit positions of the DIP switch. Use the following table for their resolution settings via the DIP switch.



DIP Switch Settings (Continued)

Micro Step Resolution (S1-S4)

Steps/Revolution	S1	S2	S3	S4
Software Configured(Default 4000)	On	On	On	On
800	Off	On	On	On
1600	On	Off	On	On
3200	Off	Off	On	On
6400	On	On	Off	On
12800	Off	On	Off	On
25600	On	Off	Off	On
51200	Off	Off	Off	On
1000	On	On	On	Off
2000	Off	On	On	Off
4000	On	Off	On	Off
5000	Off	Off	On	Off
8000	On	On	Off	Off
10000	Off	On	Off	Off
20000	On	Off	Off	Off
40000	Off	Off	Off	Off

Motor Shaft Direction (S5)

DIP switch S5 is used for changing motor shaft rotation direction. Changing position from “ON” to “OFF” or “OFF” to “ON” will reverse iES-2320 rotation direction.

Active edge of input pulse (S6)

DIP switch S6 is used for setting the active edge of a pulse signal. The motor shaft moves one micro step for each active pulse edge. Use the following table for your reference

S6	On	Off
	Active rising edge of input pulse	Active falling edge of input pulse

Current Control Detail

Leadshine s iES-2320 integrated step servo motor is integrated with a high-resolution 1,000-line optical incremental encoder. That encoder can send the real-time shaft position back to the integrated drive of the iES-2320. Like traditional servo controls, the drive can automatically adjust the output current to the motor. The output current ranges between the holding current and the close-loop current. When there is no pulse sent to the drive, the iES-2320 goes into idle mode and the actual motor current is determined by the holding current percentage (similar to “idle current” of open loop stepper drives). In normal working mode, iES-2320 monitors the actual shaft position all the time. The current outputted to the motor changes dynamically based on the tracking error between the actual position and the commanded position.



Current Control Detail (Continued)

By default, holding current percentage of the iES-2320 is 40% of the peak current and the close-loop current percentage is 70%, unless you change them from Leadshine's configuration software (see software manual). Actual current outputted to the motor can be calculated as follows:

$$\text{Holding Current} = 6A \times \text{Holding Current Percentage (\%)}$$

$$\text{MAX Close loop Current} = 6A \times \text{Close Loop Current Percentage (\%)}$$

Low holding current can reduce motor heating however also reduces the holding torque which is used to lock the motor shaft at standstill. It is recommended to determine the holding current by whether or not there is big vibration at start-up and how much lock torque is required, based on your actual applications.

Fine Tuning

Leadshine already loads default current-loop parameters and position-loop parameters. Those default parameter values have been optimized. They should be good enough for most industrial applications, and there is no need to tune them. However, if you want to fine tune the iES-2320 for best performance for your applications, Leadshine also offers tuning software, ProTuner, which allows you to adjust those current-loop and position-loop parameters (see software manual).

Typical Connections

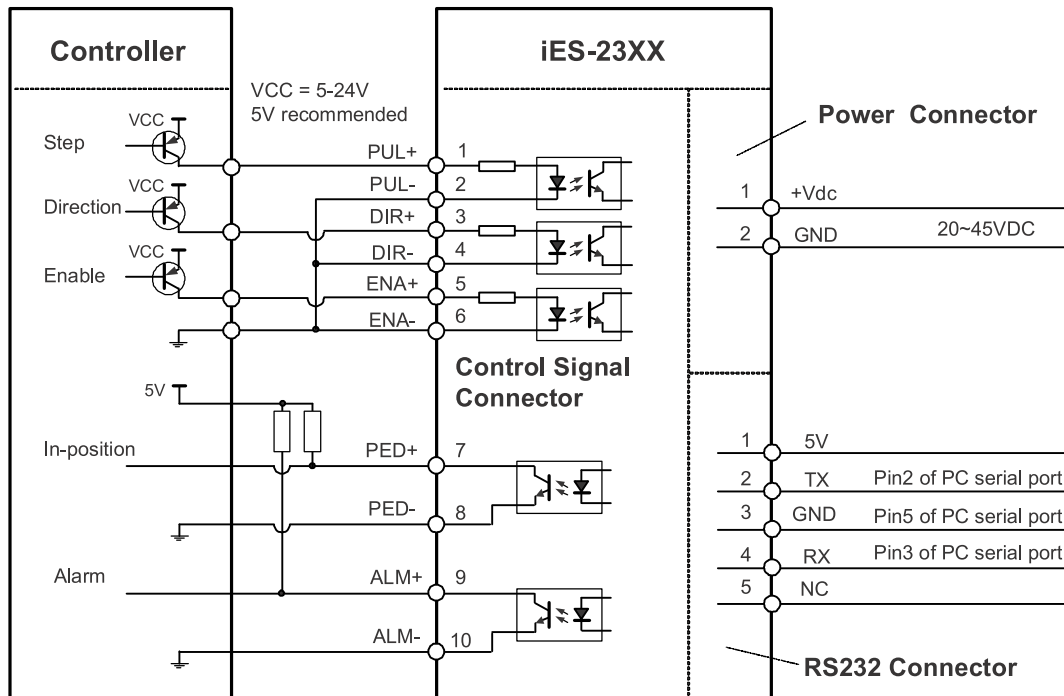

Connect iES-23XX to controller of sinking output



Typical Connections (Continued)

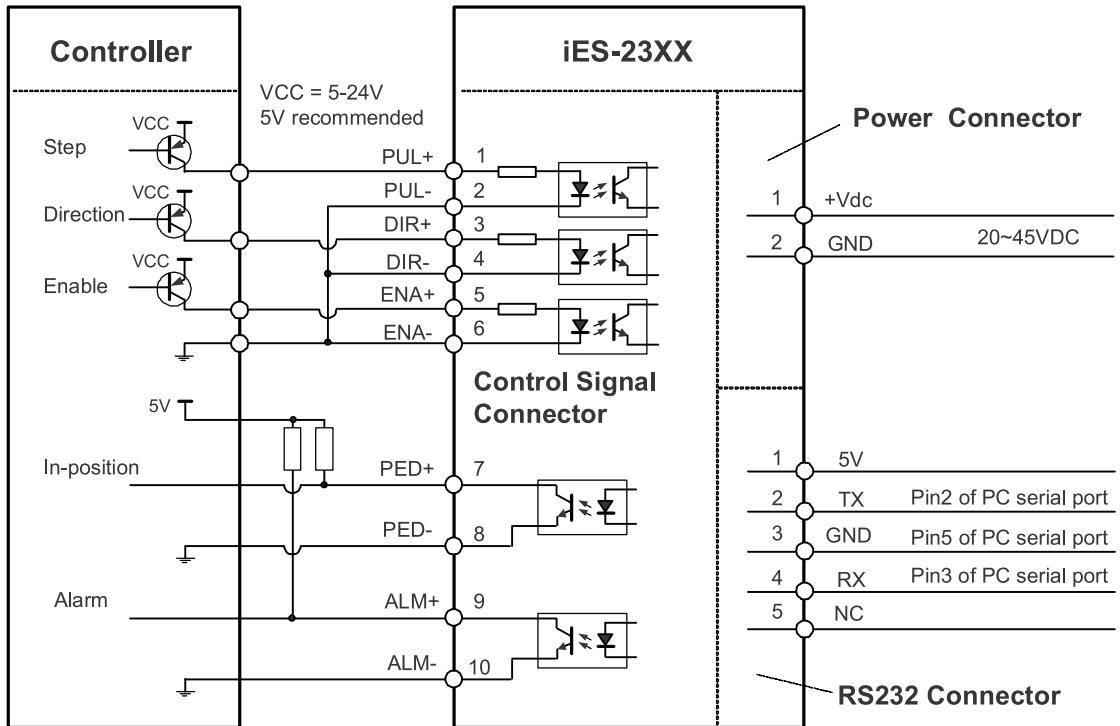

Connect iES-23XX to controller of sourcing output

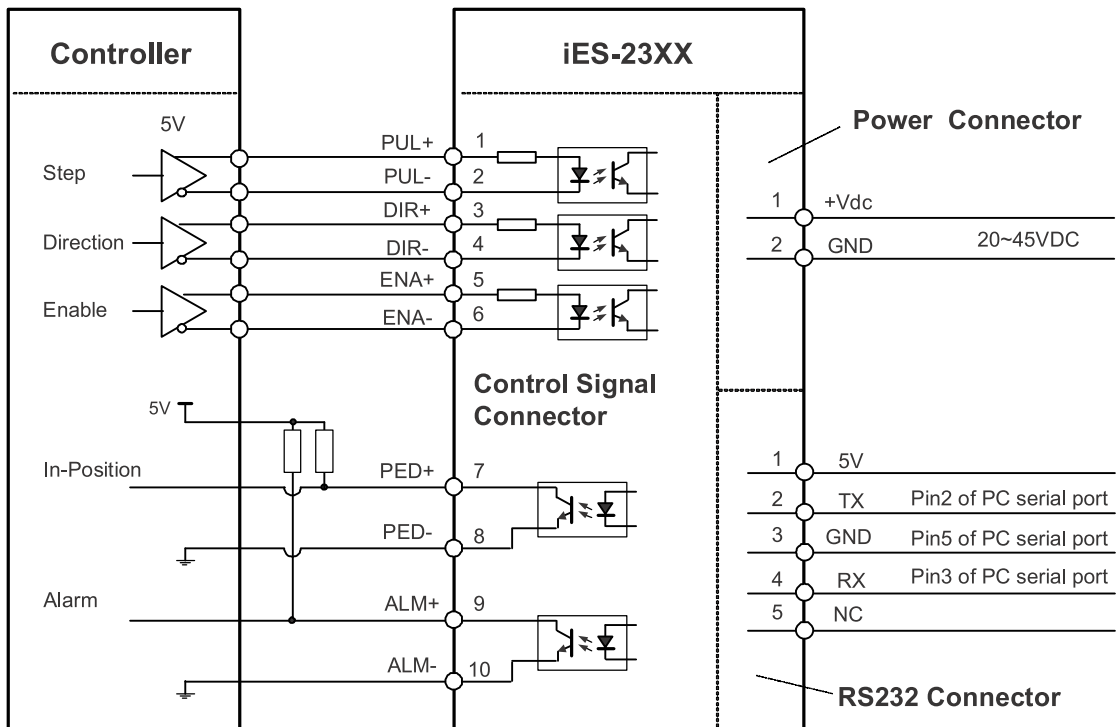

Connect iES-23XX to controller of differential output



RS232 Communication Cable Connections

Note1: The RS232 communication port is not isolated. Please use an isolated power supply for the iST-23xx when the PC's serial port is not isolated.

Note2: Do not plug or unplug the connector when power is on.

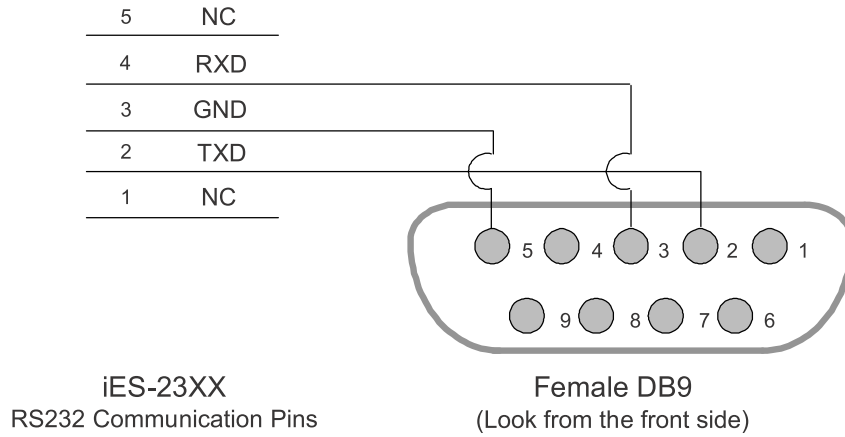

Speed-Torque Curve

Note: The following curves are based on 20% holding torque percentage and 70% close-loop current percentage of the iES-2320. If higher torque at high speed is required, you can change the holding torque percentage and close-loop current percentage to 100%. See software manual.

iES-2320

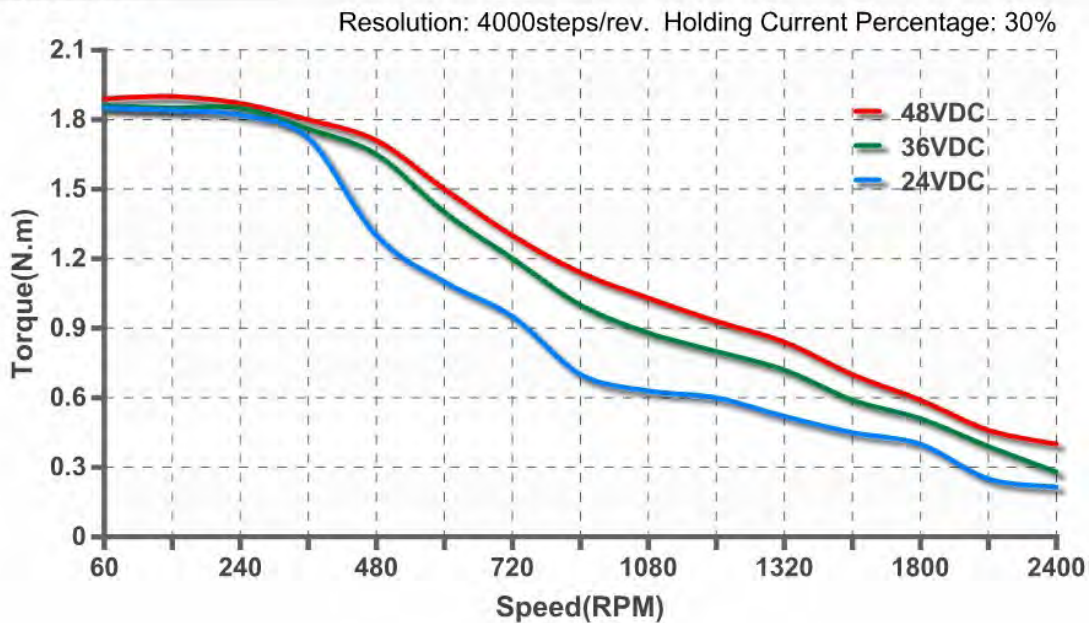

Software Operational Manual

IES Series Integrated Easy Servo

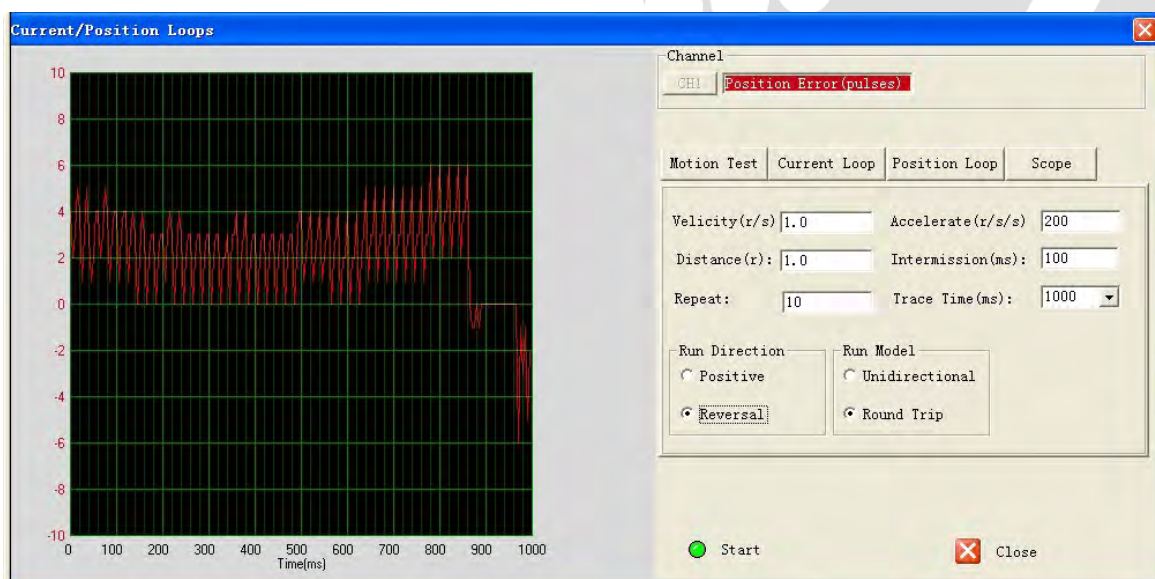

Introduction

The ProTuner is a software tool designed to configure and tune the Leadshine's IES series integrated steppers. The user can configure the drive's output current, microstep resolution, command type, tune the current loop and adjust the position loop parameters in this software.

Workspace

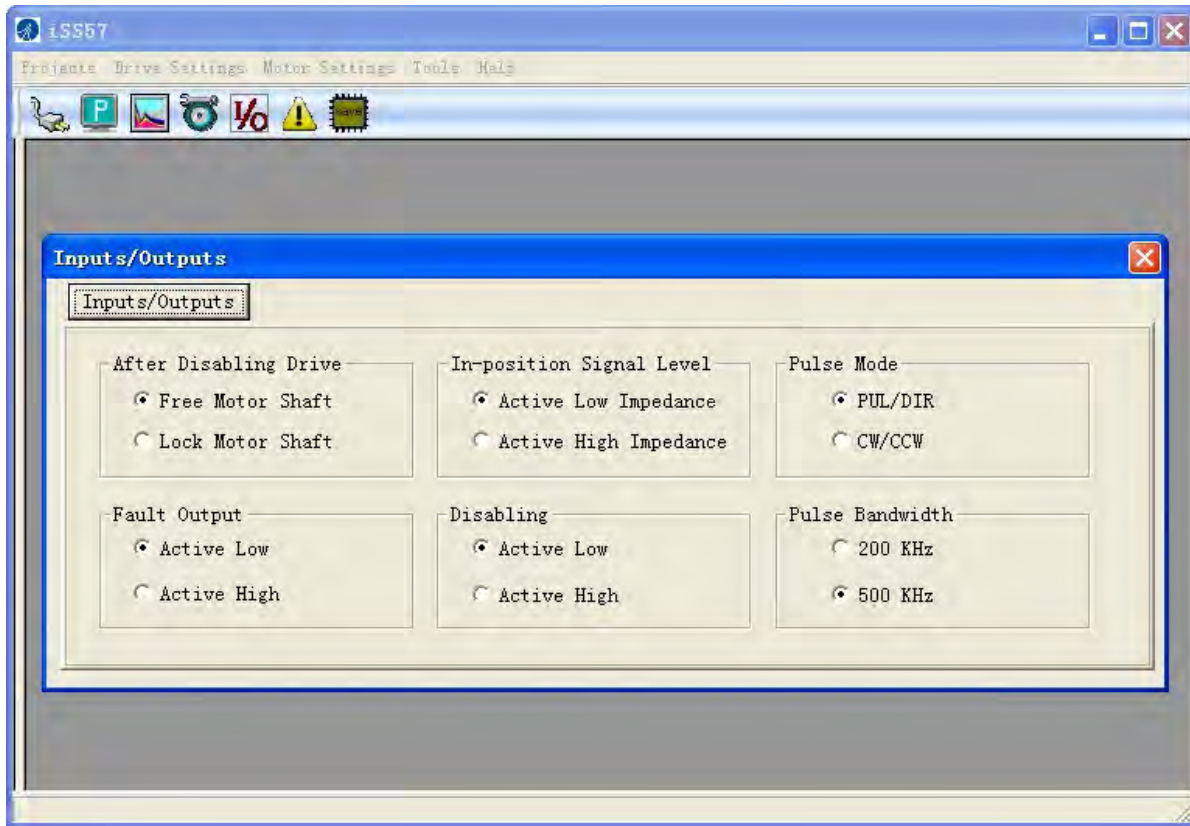

Menu
Toolbar

Setting
Window

Menus and Toolbar

Menus and toolbars are at the top of the workspace. You can click menu bar to view pull-down menu. The toolbar below offers the most frequency commands.



Menu	Pull Down	Toolbar	Function
Projects ->	Connect to Drive		Open the serial port and connect to drive
	Exit	-	Exit from ProTuner
Drive Settings->	Current / Position Loops		Tune the current loop, adjust the position loop parameter and perform Motion Test.
	Inputs / Outputs		Set the command type, active level of the I/O signal.
	Download to Drive	-	Download the settings to the drive's NVM (Non-volatile Memory).
	Reset	-	Reset all settings.
Motor Settings->	Motor Settings		Set micro step resolution, position following limit and encoder resolution.
Tools->	Parameters		Download / upload data between the ProTuner and the drive. Or you can also save parameters to a file and restore parameters from a file.
	Check Errors		Check drive error
Help->	About ProTuner		Display ProTuner information

Using the Software

Connecting Drive

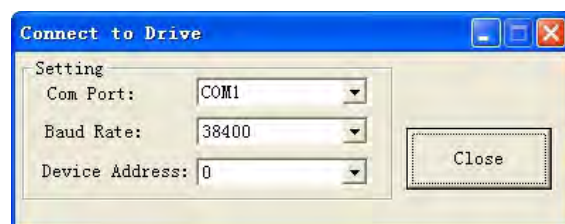

Connect to Drive window appears every time you open ProTuner. You can also open it by clicking **Projects->Connect To Drive** when the software is open. . Select the serial port number and click on the **Open**



button. The software will try to connect to the drive and read the settings. It may take several minutes. Please wait.



Before connecting the drive, please make sure:

- 1) The RS232 cable has been connected between the drive and PC serial port.
- 2) Power has been applied to the drive and the green LED is turned on.

The motor is no need to connect to the drive if you just want to change the parameters but not tuning.



Do not connect or disconnect serial cable when drive is powered on. The drive's communication circuit may be damaged.

Current / Position Loops Window

Click **Drive->Current / Position Loops** to open this window. You can adjust the current loop Kp (proportional gain) and Ki (integral gain) in this window. The user can also perform the Motion Test and adjust the position loop control parameters.

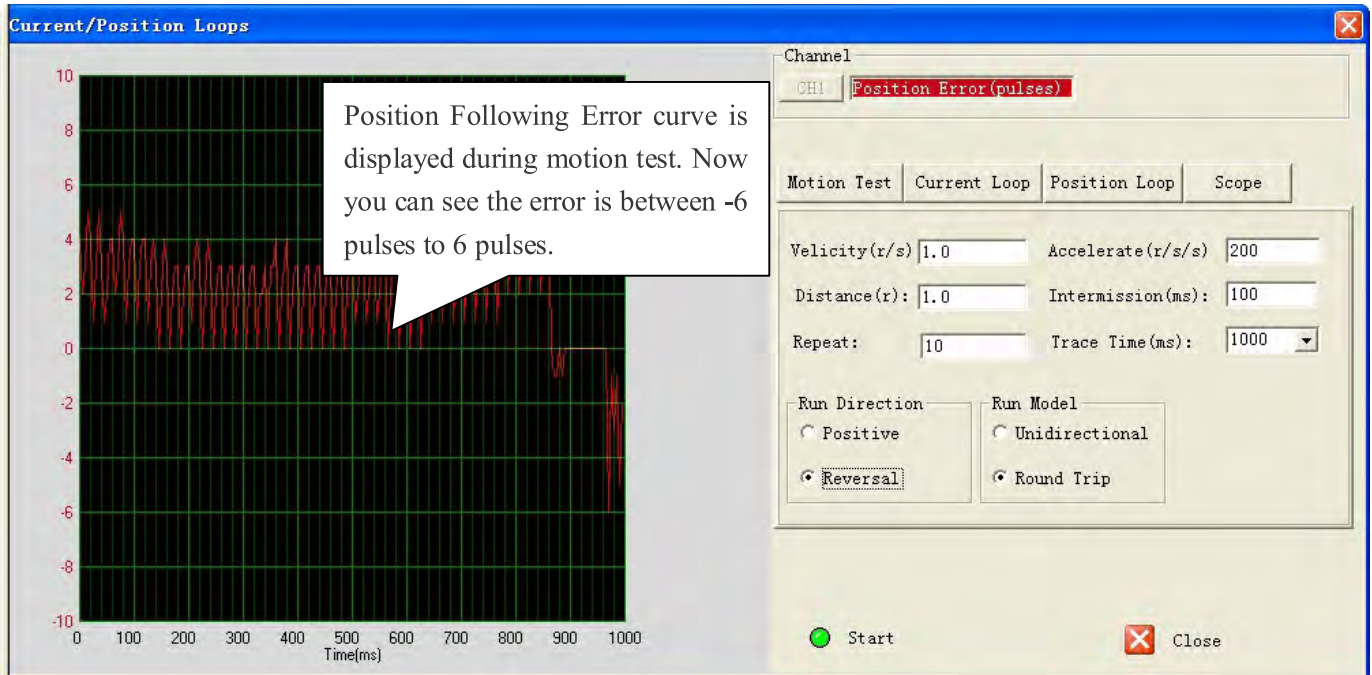

Motion Test Tab

In the Motion Test tab, you can make the motor move without pulse generator or motion controller. Configure the trapezoid velocity file first and then click the **Start** button.



Velocity(r/s) Accelerate(r/s/s)

Distance (r): Intermission(ms):

Repeat: Trace Time(ms):

Run Direction

Positive

Reversal

Run Model

Unidirectional

Round Trip

Start
 Close

Item	Description	Range
Velocity (r/s)	Target velocity of Motion Test.	1– 50 rps
Accelerate (r/r/s)	Acceleration of Motion Test.	1 – 65535 r/s ²
Distance (r)	Move distance of Motion Test.	1 – 65535 r
IntermIESion (ms)	Interval between moves.	1 – 65535 ms
Repeat	Repeat times.	1– 65535
Run Direction	Move direction.	Positive/ Reversal
Run Model	Motion Test mode includes single direction motion or two direction Motion. Unidirectional: Run in one direction, Round Trip: Run forward and back	-
Trace Time	The time to sample the position following error data.	100~3000 ms
Start	Click to start the Motion Test.	-
Stop	Stop the move immediately.	-
Close	Close the Current / Position Loops window	-

Current Loop Tab

Click **Current Loop** tab to open this window. The current loop parameter is related to the motor resistance and



inductance.



When power-up, the drive board will perform the auto-configuration and the current loop parameters will be calculated automatically. Here, this window is just for check. It is unnecessary to the current loop parameters by your self.

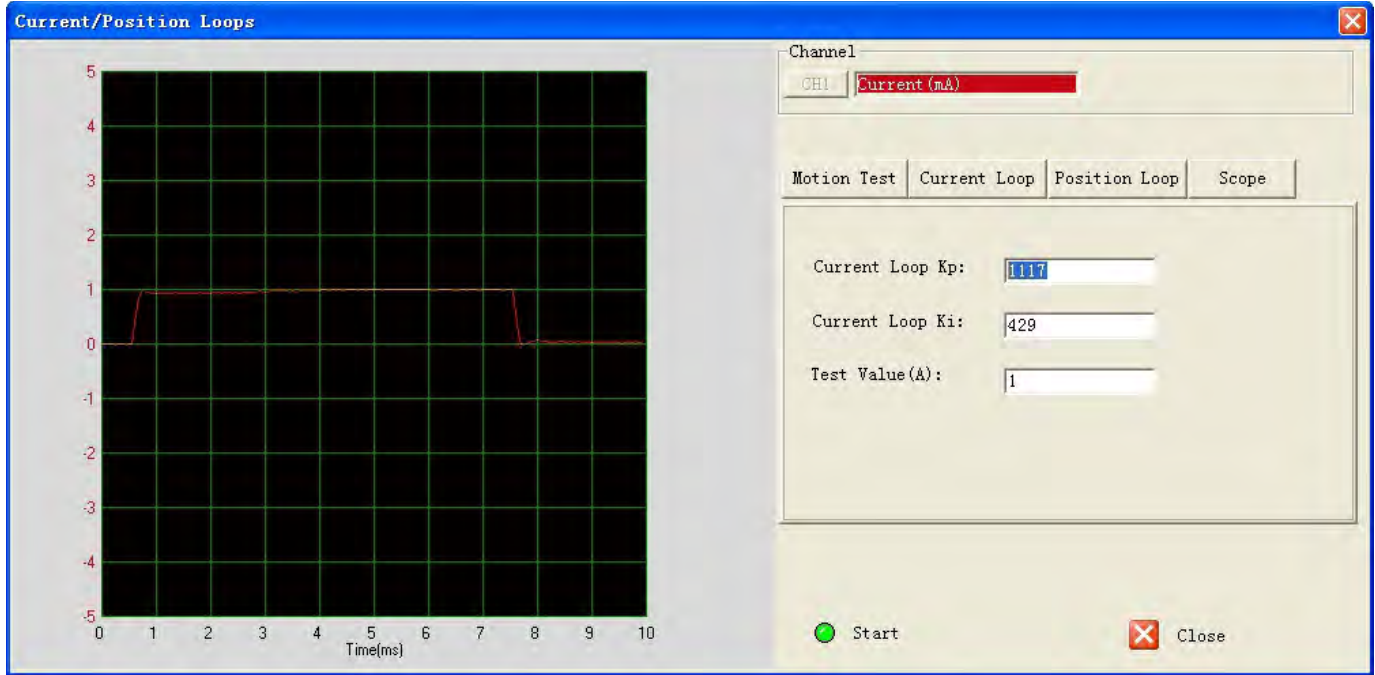

Item	Description	Range
Current Loop Kp (Proportional Gain)	Increase Kp to make current rise fast. Proportional Gain determines the response of the drive to current setting command. Low Proportional Gain provides a stable system (doesn't oscillate), has low stiffness, and large current error, causing poor performances in tracking current setting command in each step. Too large Proportional Gain values will cause oscillations and unstable systems.	1 – 65535
Current Loop Ki (Integral Gain)	Adjust Ki to reduce the steady error. Integral Gain helps the drive to overcome static current errors. A low or zero value for the Integral Gain may have current errors at rest. Increasing the Integral Gain can reduce the error. If the Integral Gain is too large, the systems may "hunt" (oscillate) about the desired position.	1 – 65535
Test Value (A)	The current amplitude for the step response. Let this value not exceed the maximum output current of the drive.	0.5-2A
Start	Enter Kp and Ki and click this button to activate the test. A target curve (red) will be displayed on the screen for user analysis.	-



Position Loop Tab

Click **Position Loop** tab to open this window. You can adjust the position loop parameter to get lower noise or fast response of the motor. Double click the value to change the parameters.



The default values of the position loop parameters have been optimized and they are suitable for most of the application. It is unnecessary to tune them when the motor runs very well. It is only recommended to adjust them when the actual performance is not good. For example, motor generates a big noise, or motor stalls easily at high speed.

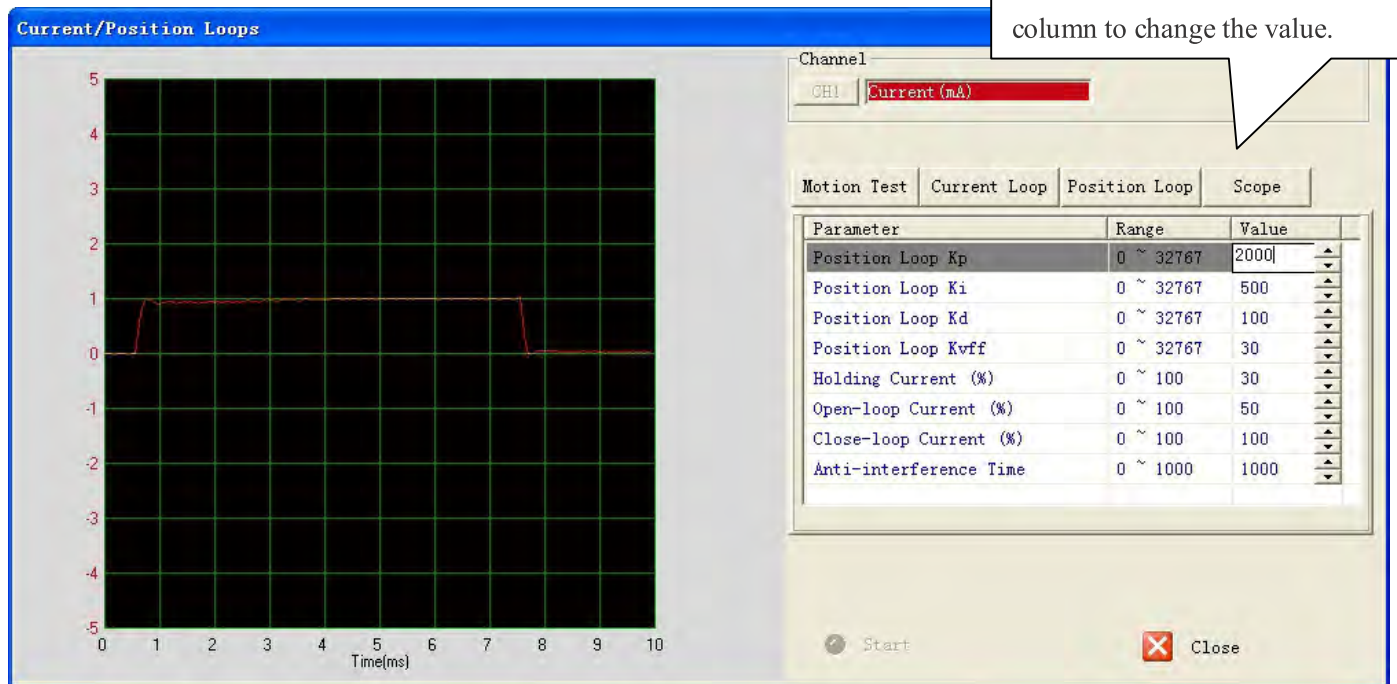

The screenshot shows a software interface for controlling a motor. On the left is a graph titled "Current/Position Loops" with a y-axis from -5 to 5 and an x-axis labeled "Time[ms]" from 0 to 10. A red line on the graph shows a step response, rising from 0 to 1 at approximately 0.5ms and returning to 0 at approximately 7.5ms. On the right is a control panel with a "Channel" dropdown set to "CHI" and "Current (mA)". Below are tabs for "Motion Test", "Current Loop", "Position Loop", and "Scope". A table lists various parameters with their ranges and current values. A callout box points to the "Value" column of the table, stating "Double click the cell in Value column to change the value." At the bottom of the panel are "Start" and "Close" buttons.

Parameter	Range	Value
Position Loop Kp	0 ~ 32767	2000
Position Loop Ki	0 ~ 32767	500
Position Loop Kd	0 ~ 32767	100
Position Loop Kvff	0 ~ 32767	30
Holding Current (%)	0 ~ 100	30
Open-loop Current (%)	0 ~ 100	50
Close-loop Current (%)	0 ~ 100	100
Anti-interference Time	0 ~ 1000	1000



Item	Description	Range
Position Loop Kp (Proportional Gain)	Position Proportional Gain. Proportional Gain determines the response of the system to position errors. Low Proportional Gain provides a stable system (doesn't oscillate), has low stiffness, and large position errors under load. Too large Proportional Gain values will cause oscillations and unstable systems.	0~ 32767
Position Loop Ki (Integral Gain)	Integral Gain. Integral Gain helps the control system overcome static position errors caused by friction or loading. The integrator increases the output value as a function of the position error summation over time. A low or zero value for the Integral Gain may have position errors at rest (that depend on the static or frictional loads and the Proportional Gain). Increasing the Integral Gain can reduce these errors. If the Integral Gain is too large, the systems may "hunt" (oscillate at low frequency) about the desired position.	0~ 32767
Position Loop Kd (Derivative Gain)	Position Derivative Gain. Derivative Gain provides damping by adjusting the output value as a function of the rate of change of error. A low value provides very little damping, which may cause overshoot after a step change in position. Large values have slower step response but may allow higher Proportional Gain to be used without oscillation.	0 – 32767
Position Loop Kvff (Feed-forward Gain)	Feed-forward gain. It speeds up the system response.	0 – 32767
Holding Current (%)	Motor current when there is no pulse applied to the drive.	0%-100%
Open-loop Current (%)	Motor current when the drive goes into open loop control mode.	0%-100%
Close-loop Current (%)	Motor current when the drive goes into close loop control mode.	0%-100%
Anti-interference Time	Ignore it.	0-1000 ms



Scope Tab

Click **Scope** tab to open this window. You can monitor the position following error in this window. When the IES motor runs in real application, this window helps to check the performance.

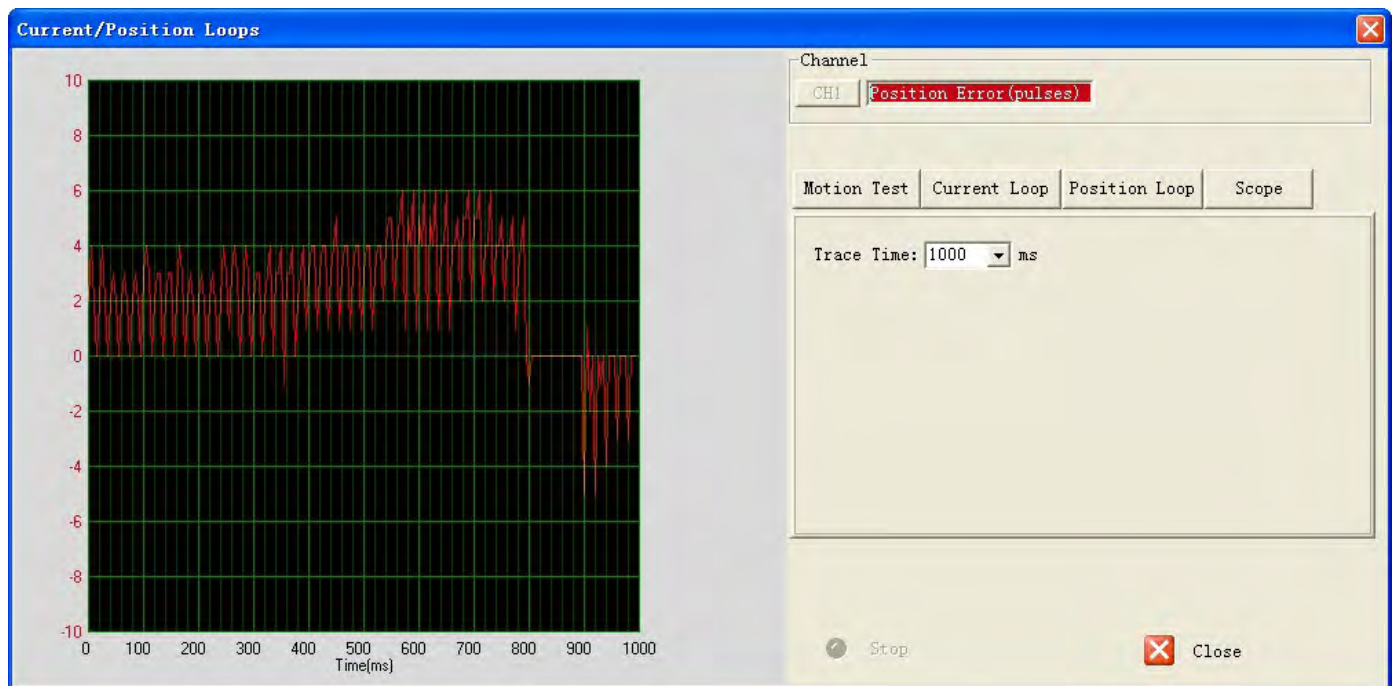

Item	Description	Range
Trace Time	Time to sample the position following error. For example, if the trace time is 1000ms, the drive board acquires the error data every 1000ms.	0~ 32767
Start	Start to monitor and display the position following error.	-
Stop	Stop monitoring.	-



Inputs/Outputs Window

Click **Drive->Inputs/Outputs** to open the I/O configuration window. You can chose to free or lock motor shaft after disabling drive, select the Pulse Active Edge, active level of In-position output, active level of fault output, active low disabling or active high disabling and pulse bandwidth.

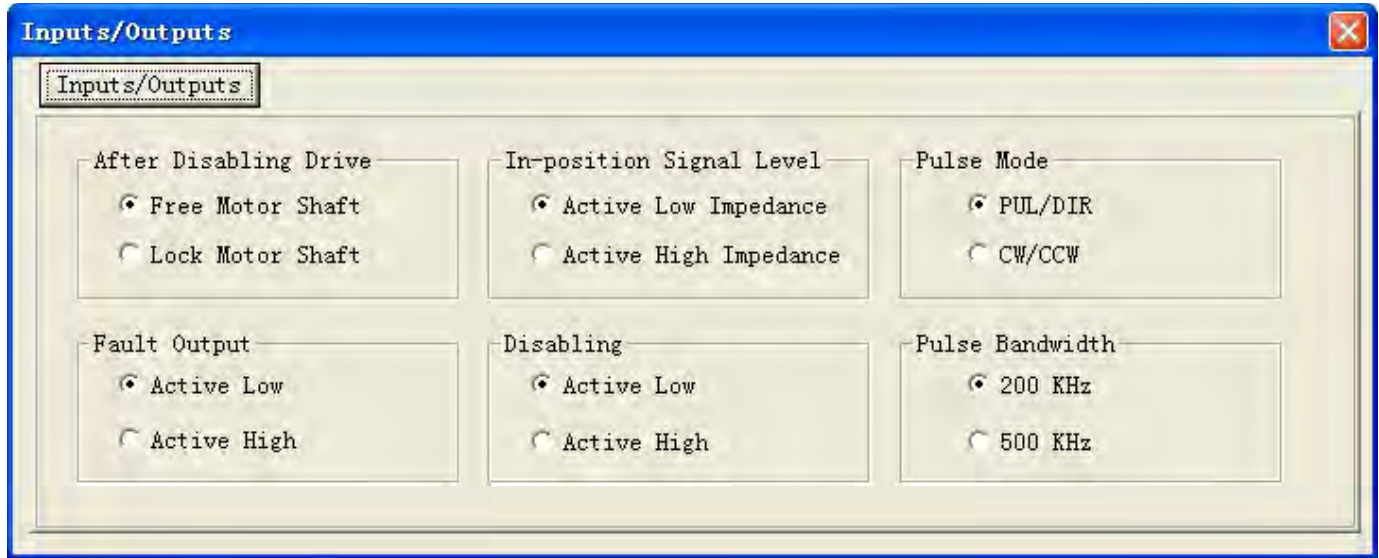

Item	Description	Range
After Disabling Drive	Select to free or lock the motor shaft after disabling drive. If the “free motor shaft” is selected, the drive board will close all the power state after disabling drive and the motor coil current is zero. You can perform manual move via the “free motor shaft” selection. Otherwise if the “lock motor shaft” is selected, the motor shaft will be lock after disabling drive and the motor current keeps as the holding current.	Free motor shaft / Lock motor shaft
In-position Signal Level	Set the active output impedance of the in-position signal. If it is active low, the impedance between PED+ and PED- is low when the target position is reached. Otherwise if it is active high, the impedance between PED+ and PED- is high when the target position is reached.	Active Low /Active High
Pulse Mode	Pulse mode of control signal. Select PUL/DIR or CW/CCW according to command type of motion controller. PUL/DIR means pulse and direction mode; CW/CCW means double pulses mode.	PUL/DIR CW/CCW



Fault Output	Set the active output impedance of the fault signal. If it is active low, the impedance between ALM+ and ALM- is low when the target position is reached. Otherwise if it is active high, the impedance between ALM+ and ALM- is high when the target position is reached.	Active Low /Active High
Disabling	Set active input level of disable signal.	Active Low /Active High
Pulse Bandwidth	Select the input pulse bandwidth or the maximum input frequency.	200K/500K

Download to Drive

The parameter values are only loaded to the drive board's RAM when you change them in ProTuner. After power-off, they will be lost. So you have to click **Drive->Download to Drive** to save all parameters to the drive board's non-volatile memory.



Reset

It is possible that the parameter value is changed by accident and you want to restore the default value. You can click **Drive->Reset** for this purpose. The following confirmation window will appear.

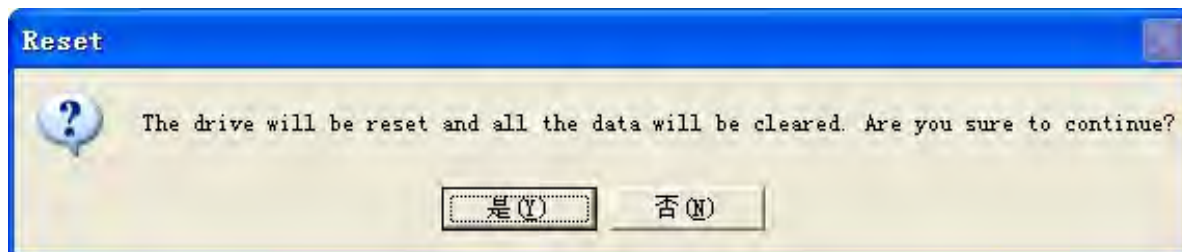

Motor Settings Window

Click **Drive->Motor Settings** to open this window. You can set the micro step resolution, position following error limit and encoder resolution in this window.



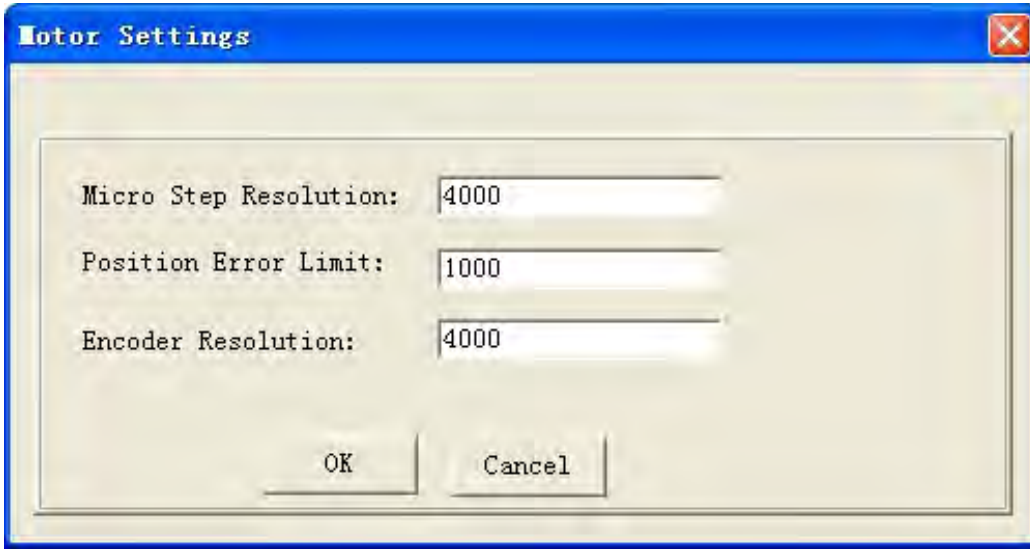

Motor Settings

Micro Step Resolution: 4000

Position Error Limit: 1000

Encoder Resolution: 4000

OK Cancel

Item	Description	Range
Micro Step Resolution	Drive's Micro Step setting for the motor.	1~51200
Position Error Limit	The limit of the difference between commanded position and the actual measured position. When position following error exceeds the Position Following Error Limit in the drive, the following error protection will be activated.	0~65535
Encoder Resolution	The encoder lines. 4 × of the actual resolution. For example, if the encoder resolution is 1000, it is 4000. Note: Do not change the default value as it must be corresponded to the actual encoder resolution.	200-10000

Parameters Operation

Click **Tools->Parameters** to open the parameter operation window. You can deal with the drive parameters in this window as follows:

- 1) **Read Drive:** Read parameters from the drive;
- 2) **Load To Drive:** Load parameters to drive;
- 3) **Open File:** Open a PC configuration file with .lsr extension and load parameters drive;
- 4) **Save File:** Save the parameters to a PC configuration file with .lsr extension;
- 5) **Download to Drive:** Download parameters to the drive's nonvolatile memory;
- 6) **Reset:** Restore factory settings of the drive.



Read Drive

Click “Read drive” button to upload all parameters from drive. Double click the value of the parameter, you can change the value.

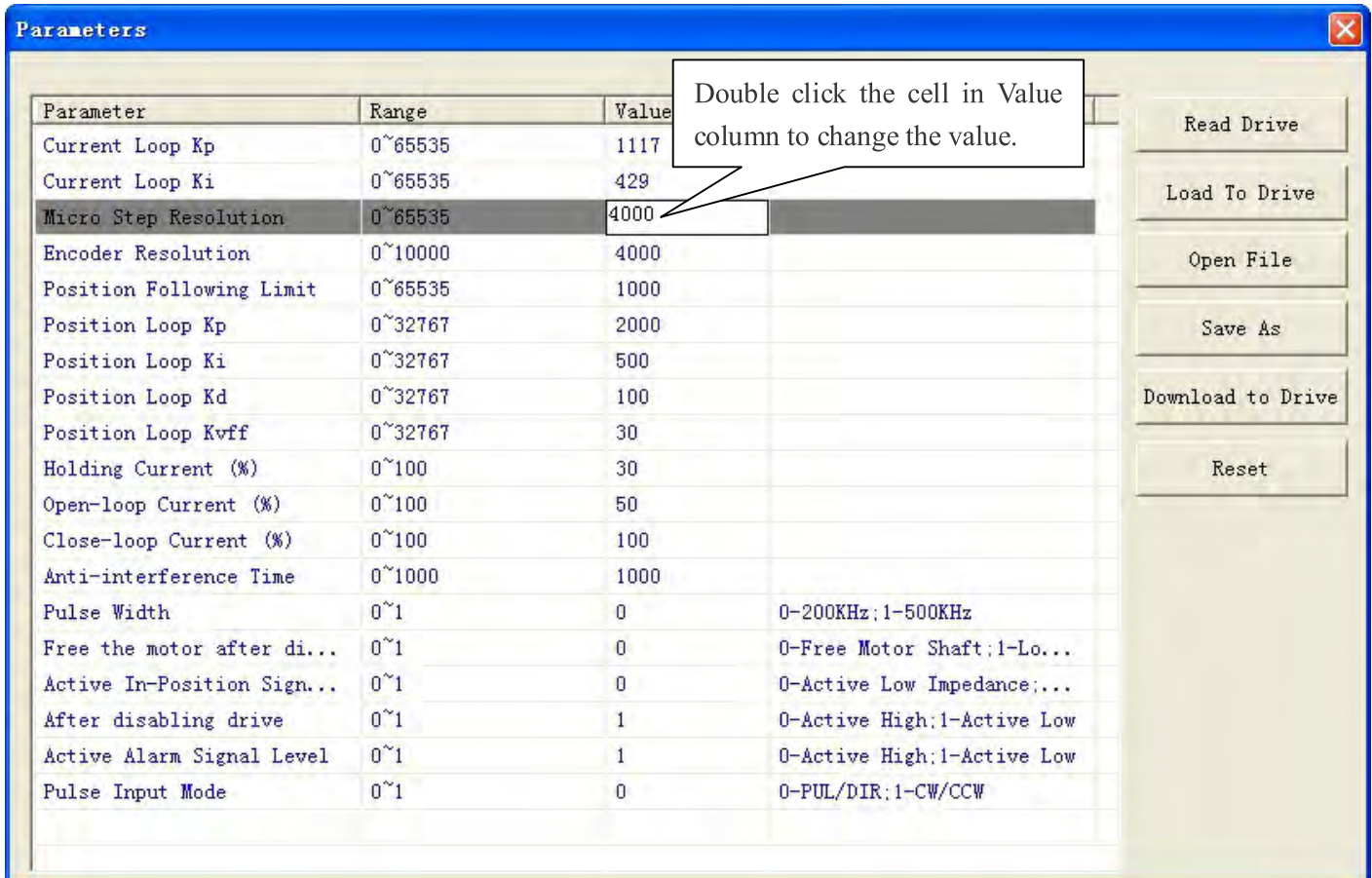

Parameters

Parameter	Range	Value	
Current Loop Kp	0~65535	1117	
Current Loop Ki	0~65535	429	
Micro Step Resolution	0~65535	4000	
Encoder Resolution	0~10000	4000	
Position Following Limit	0~65535	1000	
Position Loop Kp	0~32767	2000	
Position Loop Ki	0~32767	500	
Position Loop Kd	0~32767	100	
Position Loop Kvff	0~32767	30	
Holding Current (%)	0~100	30	
Open-loop Current (%)	0~100	50	
Close-loop Current (%)	0~100	100	
Anti-interference Time	0~1000	1000	
Pulse Width	0~1	0	0-200KHz;1-500KHz
Free the motor after di...	0~1	0	0-Free Motor Shaft;1-Lo...
Active In-Position Sign...	0~1	0	0-Active Low Impedance;...
After disabling drive	0~1	1	0-Active High;1-Active Low
Active Alarm Signal Level	0~1	1	0-Active High;1-Active Low
Pulse Input Mode	0~1	0	0-PUL/DIR;1-CW/CCW

Buttons: Read Drive, Load To Drive, Open File, Save As, Download to Drive, Reset

Callout: Double click the cell in Value column to change the value.

Open File

If you want to load parameters from a PC file, click **Open File** button in the **Parameters** Window. The parameters in the software’s workspace will be updated.

Save File

Click **Save File** button to save the parameter of current workspace to a file. This file can be used for the other drive.

Download to Drive

Click **Download** button to download the changes to the drive’s nonvolatile memory.



Check Errors

You can check the active error or the error log of the drive in this window. Type of error is shown as follows:

Item	Description
Over Current Error	Error occurs when the motor coil current exceeds the drive's current limit.
Over Voltage Error	Error occurs when the input voltage exceeds the drive's voltage limit
Position Following Error	Error occurs when the actual position following error exceeds the limit which is set in Position Error Limit .

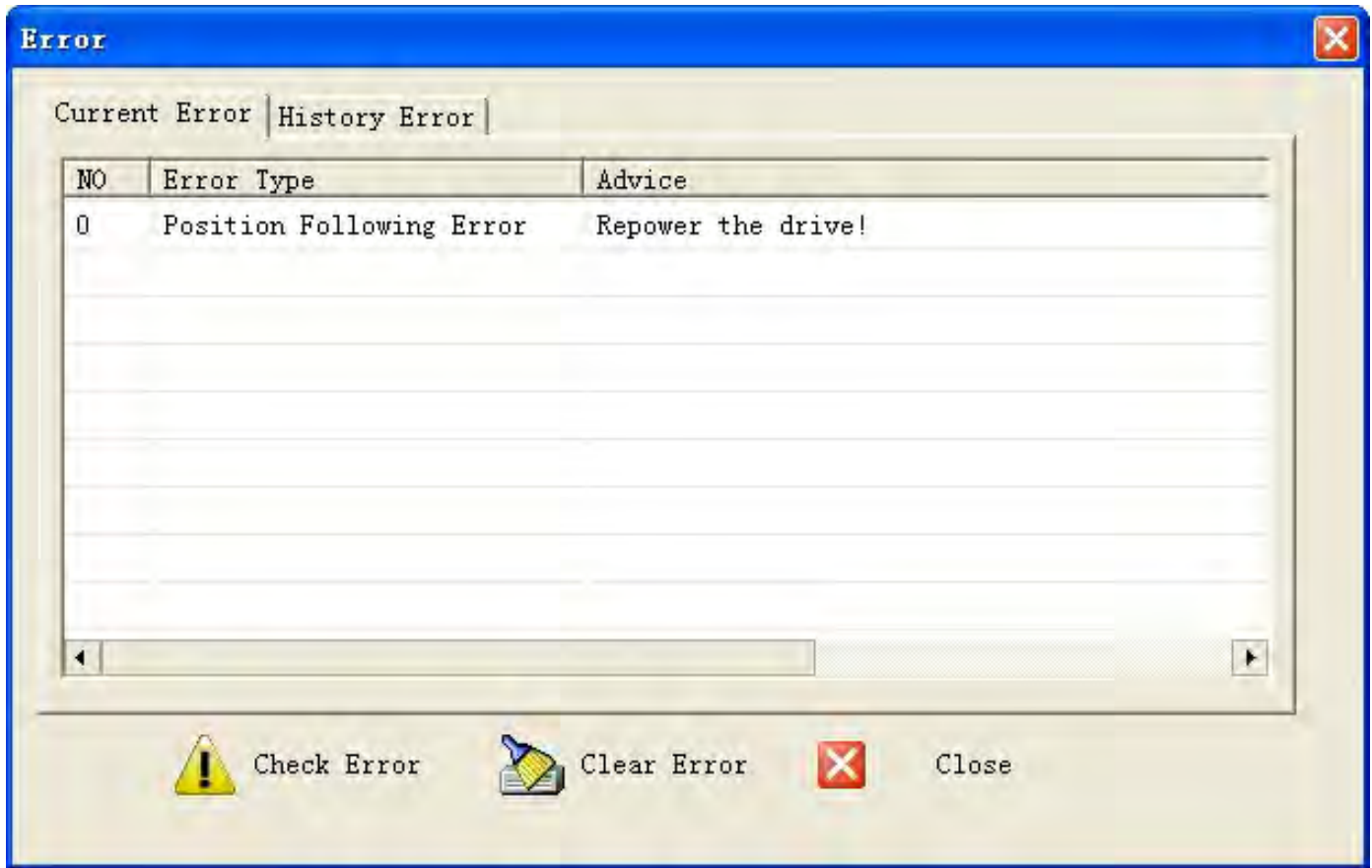

Configuring the Drive

Usually, you can follow the steps below to configure the drive.

- 1) Set Input/Output parameters such as pulse mode, pulse bandwidth, pulse active edge, active level of fault output, position following limit and micro step resolution for your application.
- 2) Adjust the position loop parameters when lower noise or fast speed is required.



The motor must be connected to the drive before trying to configure the drive.

Configuring Inputs/Outputs

Click **Drive->Inputs/Outputs** to open the setting window. You can set pulse mode, pulse active edge, active impedance of fault output and pulse bandwidth in this window See more information in **Using the Software** chapter.

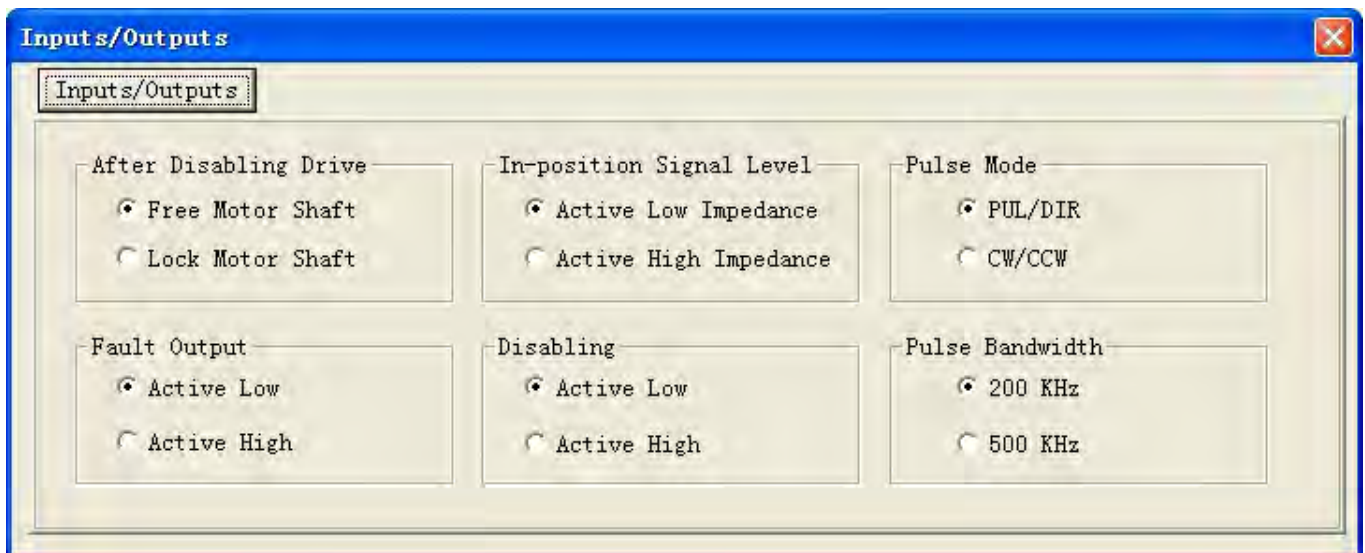

Configuring Motor Settings

Click **Drive->Motor Settings** to open the motor setting window. You can set the micro step resolution, position error limit and check the encoder resolution in this window. See more information in **Using the Software** chapter.

The microstep resolution can be set from 200- 51200 with step 1. High resolution Micro Step makes the motor move more smoothly. Low Micro Step resolution reduces the high frequency requirement to the controller. If the application requires small position following error, reduce the **Position Error Limit**. Usually it is recommended to set it to 1000.



Do not change the default value as it must be corresponded to the actual encoder resolution.





Do not change the default value as it must be corresponded to the actual encoder resolution.

Fine Tuning of Position Loop



Leadshine already loads default current-loop parameters and position-loop parameters. Those default parameter values have been optimized. They should be good enough for most industrial applications, and there is no need to tune them. However, if you want to fine tune the IES for best performance for your applications, ProTuner allows you to adjust those current-loop and position-loop parameters

To adjust the position loop parameter, click **Drive->Current Loop / Position Loops** to open the window. Then click the **Position Loop tab**. The position loop parameters appear and you can adjust them by the steps as follows:

- 1) Select the row.
- 2) Double click the cell value in Value column. The number will be selected and you can change it.
- 3) Click other place to confirm the input.

See more information in **Using the Software** chapter.



The effect of K_p , K_d , K_i and K_vff is similar as the items in servo control system. But they are not completely the same. You do can not tune them as you done in servo system. The adjustable range of K_p , K_d , K_i and K_vff is from 0-32767. However, do not give too low or high value to these parameters. It is recommended to adjust them by 10%-30%. Otherwise the drive's performance may go bad!

Tuning Tips

Faster Response, High Speed, High Torque, Smooth Move	Increase the K_p , K_d , K_vff , Open-Loop Current and Close-loop Current.
Lower Motor Noise, Lower Motor Heating	Decrease the K_p , K_d , K_vff , Open-Loop Current and Close-loop Current



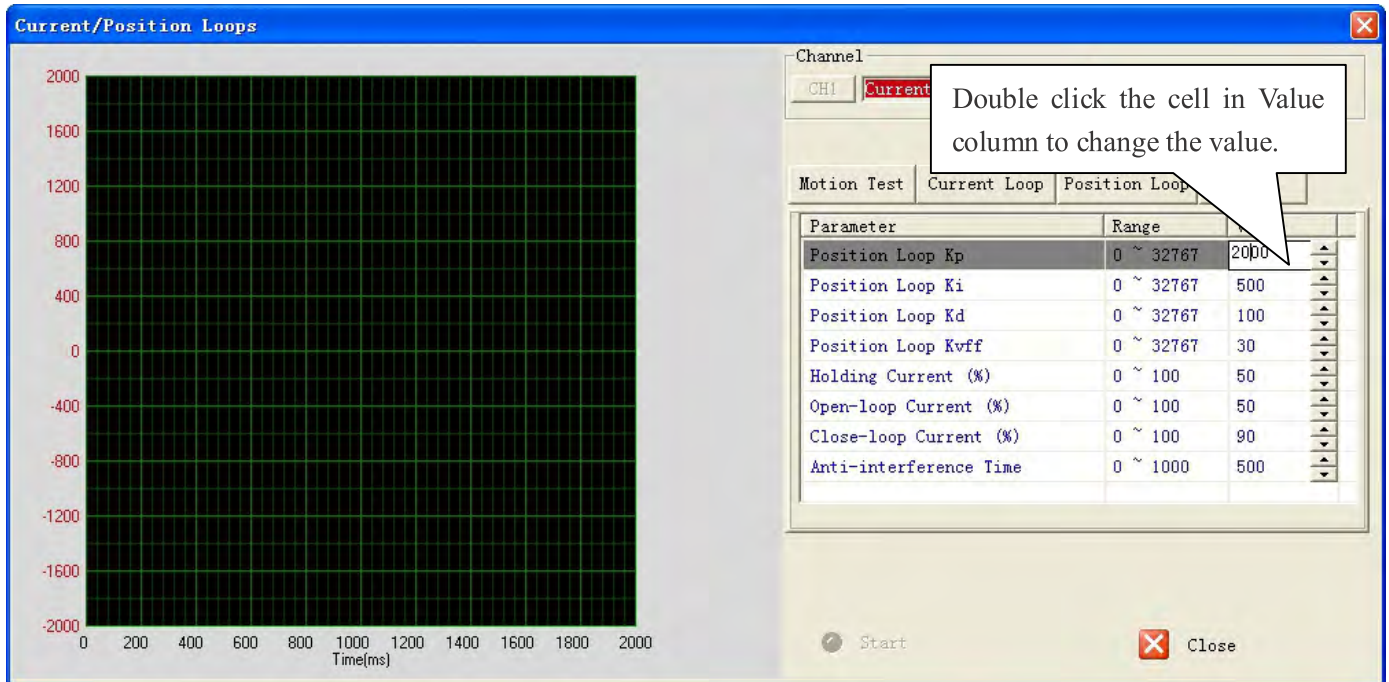

Output Current

The output current ranges between the holding current and the close-loop current. When there is no pulse sent to the drive, the IES goes into idle mode and the actual motor current is determined by the holding current percentage (similar to “idle current” of open loop stepper drives). In normal working mode, the IES monitors the actual shaft position all the time. The current outputted to the motor changes dynamically based on the tracking error between the actual position and the commanded position.

By default, holding current percentage of the IES is 40% of the peak current and the close-loop current percentage is 100%, unless you change them from Leadshine’s configuration software (see software manual). Actual current outputted to the motor can be calculated as follows:

$$\text{Holding Current} = 6A \times \text{Holding Current Percentage (\%)}$$

$$\text{MAX Close loop Current} = 6A \times \text{Close Loop Current Percentage (\%)}$$

Low holding current can reduce motor heating however also reduces the holding torque which is used to lock the motor shaft at standstill. It is recommended to determine the holding current by whether or not there is big vibration at start-up and how much lock torque is required, based on your actual applications.



The holding current also affects the torque at high speed! If the motor can not run into high speed with default holding current, try to increase the holding current to 80% to 100%. However, motor heating at standstill may be increased too.

