



Ball Screw

THK General Catalog

Ball Screw

THK General Catalog

A Product Descriptions

Types of Ball Screws	A 15-6
Point of Selection	A 15-8
Flowchart for Selecting a Ball Screw	A 15-8
Accuracy of the Ball Screw	A 15-11
• Lead Angle Accuracy	A 15-11
• Accuracy of the Mounting Surface	A 15-14
• Axial Clearance	A 15-19
• Preload	A 15-20
Selecting a Screw Shaft	A 15-24
• Maximum Length of the Screw Shaft	A 15-24
• Standard Combinations of Shaft Diameter and Lead for the Precision Ball Screw	A 15-26
• Standard Combinations of Shaft Diameter and Lead for the Rolled Ball Screw	A 15-27
Method for Mounting the Ball Screw Shaft	A 15-28
Permissible Axial Load	A 15-30
Permissible Rotational Speed	A 15-32
Selecting a Nut	A 15-35
• Types of Nuts	A 15-35
Selecting a Model Number	A 15-40
• Calculating the Axial Load	A 15-40
• Static Safety Factor	A 15-41
• Studying the Service Life	A 15-42
Studying the Rigidity	A 15-45
• Axial Rigidity of the Feed Screw System	A 15-45
Studying the Positioning Accuracy	A 15-49
• Causes of Error in the Positioning Accuracy	A 15-49
• Studying the Lead Angle Accuracy	A 15-49
• Studying the Axial Clearance	A 15-49
• Studying the Axial Clearance of the Feed Screw System	A 15-51
• Studying the Thermal Displacement through Heat Generation	A 15-53
• Studying the Orientation Change during Traveling	A 15-54
Studying the Rotational Torque	A 15-55
• Frictional Torque Due to an External Load	A 15-55
• Torque Due to a Preload on the Ball Screw	A 15-56
• Torque Required for Acceleration	A 15-57
• Investigating the Terminal Strength of Ball Screw Shafts	A 15-58
Studying the Driving Motor	A 15-60
• When Using a Servomotor	A 15-60
• When Using a Stepping Motor (Pulse Motor)	A 15-62
Features of Each Model	A 15-63
Precision, Caged Ball Screw	
Models SBN-V, SBK, SDA-V, HBN and SBKH	A 15-64
• Structure and Features	A 15-65
• Ball Cage Effect	A 15-65
• Types and Features	A 15-68
• Examples of Assembling Models HBN and SBKH	A 15-70

Dimensional Drawing, Dimensional Table

Model SBN-V	A 15-72
Model SBK	A 15-76
Model SDA-V	A 15-80
Model HBN	A 15-86
Model SBKH	A 15-88

Models EBA, EBB, EBC, EPA, EPB and EPC

• Structure and Features	A 15-91
• Types and Features	A 15-92
• Accuracy Standards	A 15-93

Dimensional Drawing, Dimensional Table

Model EBA (Oversized-ball preload type or non-preloaded type)	A 15-94
Model EBB (Oversized-ball preload type or non-preloaded type)	A 15-96
Model EBC (Oversized-ball preload type or non-preloaded type)	A 15-98
Model EPA (Offset Preload Type)	A 15-100
Model EPB (Offset Preload Type)	A 15-102
Model EPC (Offset Preload Type)	A 15-104

Unfinished Shaft Ends Precision Ball Screw

Models BIF, MDK, MBF and BNF	A 15-106
• Structure and Features	A 15-107
• Types and Features	A 15-108
• Nut Types and Axial Clearance	A 15-109

Dimensional Drawing, Dimensional Table

Unfinished Shaft Ends	A 15-110
-----------------------------	----------

Finished Shaft Ends Precision Ball Screw

Model BNK	A 15-132
• Features	A 15-133
• Types and Features	A 15-133
• Table of Ball Screw Types with Finished Shaft Ends and the Corresponding Support Units and Nut Brackets	A 15-134

Dimensional Drawing, Dimensional Table

BNK0401-3 Shaft diameter: 4; lead: 1	A 15-136
BNK0501-3 Shaft diameter: 5; lead: 1	A 15-138
BNK0601-3 Shaft diameter: 6; lead: 1	A 15-140
BNK0801-3 Shaft diameter: 8; lead: 1	A 15-142
BNK0802-3 Shaft diameter: 8; lead: 2	A 15-144
BNK0810-3 Shaft diameter: 8; lead: 10	A 15-146
BNK1002-3 Shaft diameter: 10; lead: 2	A 15-148
BNK1004-2.5 Shaft diameter: 10; lead: 4	A 15-150
BNK1010-1.5 Shaft diameter: 10; lead: 10	A 15-152
BNK1202-3 Shaft diameter: 12; lead: 2	A 15-154
BNK1205-2.5 Shaft diameter: 12; lead: 5	A 15-156
BNK1208-2.6 Shaft diameter: 12; lead: 8	A 15-158

BNK1402-3 Shaft diameter: 14; lead: 2 ..	A15-160
BNK1404-3 Shaft diameter: 14; lead: 4 ..	A15-162
BNK1408-2.5 Shaft diameter: 14; lead: 8 ..	A15-164
BNK1510-5.6 Shaft diameter: 15; lead: 10 ..	A15-166
BNK1520-3 Shaft diameter: 15; lead: 20 ..	A15-168
BNK1616-3.6 Shaft diameter: 16; lead: 16 ..	A15-170
BNK2010-2.5 Shaft diameter: 20; lead: 10 ..	A15-172
BNK2020-3.6 Shaft diameter: 20; lead: 20 ..	A15-174
BNK2520-3.6 Shaft diameter: 25; lead: 20 ..	A15-176

Precision Ball Screw

Models BIF-V, DIK, BNFN-V/BNFN, DKN, BLW, BNF-V/BNF, DK, MDK, WHF, BLK/WGF and BNT ..	A15-178
• Structure and Features	A15-179
• Types and Features	A15-180

Dimensional Drawing, Dimensional Table

Preload Type of Precision Ball Screw....	A15-184
No Preload Type of Precision Ball Screw ..	A15-204
No Preload Type of Precision Ball Screw (Square Nut) ..	A15-228
• Model Number Coding	A15-230

Precision Rotary Ball Screw

Models DIR and BLR	A15-232
• Structure and Features	A15-233
• Type	A15-235
• Accuracy Standards	A15-236
• Example of Assembly	A15-238

Dimensional Drawing, Dimensional Table

Model DIR Standard Lead Rotary-Nut Ball Screw ..	A15-240
Model BLR Large Lead Rotary-Nut Ball Screw ..	A15-242
• Permissible Rotational Speeds for Rotary Ball Screws ..	A15-244

Precision Ball Screw/Spline

Models BNS-A, BNS, NS-A and NS	A15-246
• Structure and Features	A15-247
• Type	A15-248
• Accuracy Standards	A15-249
• Action Patterns	A15-250
• Example of Assembly	A15-253
• Example of Use	A15-254
• Precautions on Use	A15-255

Dimensional Drawing, Dimensional Table

Model BNS-A Compact Type: Linear-Rotary Motion	A15-256
Model BNS Heavy Load Type: Linear-Rotary Motion	A15-258
Model NS-A Compact Type: Linear Motion	A15-260
Model NS Heavy Load Type: Linear Motion ..	A15-262

Roller Ball Screw

Models JPF, BTK-V, MTF, WHF, BLK/WTF, CNF and BNT ..	A15-264
• Structure and Features	A15-265
• Types and Features	A15-266

Dimensional Drawing, Dimensional Table

Preload Type of Rolled Ball Screw	A15-270
No Preload Type of Rolled Ball Screw....	A15-272
No Preload Type of Rolled Ball Screw (Square Nut) ..	A15-280
• Model Number Coding	A15-283

Standard Unfinished Shaft Ends Rolled Ball Screw

Model MTF	A15-284
• Structure and Features	A15-285
• Types and Features	A15-285

Dimensional Drawing, Dimensional Table

Unfinished Shaft Ends Rolled Ball Screw Model MTF ..	A15-286
--	---------

Roller Rotary Ball Screw

Model BLR	A15-288
• Structure and Features	A15-289
• Type	A15-289
• Accuracy Standards	A15-290
• Example of Assembly	A15-291

Dimensional Drawing, Dimensional Table

Model BLR Large Lead Rotary Nut Rolled Ball Screw ..	A15-294
• Maximum Length of the Ball Screw Shaft ..	A15-296

Ball Screw Peripherals

Model BLR Large Lead Rotary Nut Rolled Ball Screw ..	A15-299
--	---------

Support Unit

Models EK, BK, FK, EF, BF and FF	A15-300
• Structure and Features	A15-300
• Type	A15-302
• Types of Support Units and Applicable Screw Shaft Outer Diameters ..	A15-303
• Model Numbers of Bearings and Characteristic Values ..	A15-304
• Example of Installation	A15-305
• Mounting Procedure	A15-306
• Types of Recommended Shapes of the Shaft Ends ..	A15-308

Dimensional Drawing, Dimensional Table

Model EK Square Type Support Unit on the Fixed Side ..	A15-310
Model BK Square Type Support Unit on the Fixed Side ..	A15-312
Model FK Round Type Support Unit on the Fixed Side ..	A15-314
Model EF Square Type Support Unit on the Supported Side ..	A15-318
Model BF Square Type Support Unit on the Supported Side ..	A15-320
Model FF Round Type Support Unit on the Supported Side ..	A15-322

Recommended Shapes of Shaft Ends - Shape H (H1, H2 and H3) (For Support Unit Models FK and EK) ..	A 15-324
Recommended Shapes of Shaft Ends - Shape J (J1, J2 and J3) (For Support Unit Model BK) ..	A 15-326
Recommended Shapes of Shaft Ends - Shape K (For Support Unit Models FF, EF and BF)....	A 15-328
Nut Bracket (Model MC)	A 15-330
• Structure and Features	A 15-330
• Type	A 15-330
Dimensional Drawing, Dimensional Table	
Nut Bracket.....	A 15-331
Lock Nut (Model RN)	A 15-332
• Structure and Features	A 15-332
• Type	A 15-332
Dimensional Drawing, Dimensional Table	
Lock Nut	A 15-333
Options	A 15-335
Contaminaton Protection	A 15-336
Lubrication	A 15-337
Corrosion Resistance (Surface Treatment, etc.) ..	A 15-337
Contamination Protection Seal for Ball Screws ..	A 15-338
Wiper Ring W	A 15-339
Dust Cover for Ball Screws.....	A 15-341
QZ Lubricator.....	A 15-342
Dimensions of Each Model with an Option Attached ..	A 15-344
• Dimensions of the Ball Screw Nut Attached with Wiper Ring W and QZ Lubricator ..	A 15-344
• Specifications of the Bellows	A 15-352
Model No.	A 15-353
• Model Number Coding	A 15-353
• Notes on Ordering.....	A 15-357
Precautions on Use	A 15-358
Precautions on Using Options for the Ball Screw .	A 15-360
• QZ Lubricator for the Ball Screw	A 15-360

B Support Book (Separate)

Features and Types	B 15-6
Features of the Ball Screw	B 15-6
• Driving Torque One Third of the Sliding Screw ..	B 15-6
• Examples of Calculating Driving Torque	B 15-8
• Ensuring High Accuracy	B 15-9
• Capable of Micro Feeding	B 15-10
• High Rigidity without Backlash	B 15-11
• Capable of Fast Feed	B 15-12
Types of Ball Screws	B 15-14
Point of Selection	B 15-16
Flowchart for Selecting a Ball Screw	B 15-16
Accuracy of the Ball Screw	B 15-19
• Lead Angle Accuracy	B 15-19
• Accuracy of the Mounting Surface	B 15-22
• Axial Clearance	B 15-27
• Preload	B 15-28
• Example of calculating the preload torque	B 15-31
Selecting a Screw Shaft	B 15-32
• Maximum Length of the Screw Shaft	B 15-32
• Standard Combinations of Shaft Diameter and Lead for the Precision Ball Screw ..	B 15-34
• Standard Combinations of Shaft Diameter and Lead for the Rolled Ball Screw ..	B 15-35
Method for Mounting the Ball Screw Shaft ..	B 15-36
Permissible Axial Load	B 15-38
Permissible Rotational Speed	B 15-40
Selecting a Nut	B 15-43
• Types of Nuts	B 15-43
Selecting a Model Number	B 15-46
• Calculating the Axial Load	B 15-46
• Static Safety Factor	B 15-47
• Studying the Service Life	B 15-48
Studying the Rigidity	B 15-51
• Axial Rigidity of the Feed Screw System ..	B 15-51
Studying the Positioning Accuracy	B 15-55
• Causes of Error in the Positioning Accuracy ..	B 15-55
• Studying the Lead Angle Accuracy	B 15-55
• Studying the Axial Clearance	B 15-55
• Studying the Axial Clearance of the Feed Screw System ..	B 15-57
• Example of considering the rigidity of a feed screw system ..	B 15-57
• Studying the Thermal Displacement through Heat Generation ..	B 15-59
• Studying the Orientation Change during Traveling ..	B 15-60
Studying the Rotational Torque	B 15-61
• Frictional Torque Due to an External Load ..	B 15-61
• Torque Due to a Preload on the Ball Screw ..	B 15-62
• Torque Required for Acceleration	B 15-63
• Investigating the Terminal Strength of Ball Screw Shafts ..	B 15-64
Studying the Driving Motor	B 15-66
• When Using a Servomotor	B 15-66
• When Using a Stepping Motor (Pulse Motor) ..	B 15-68
Examples of Selecting a Ball Screw	B 15-69
• High-speed Transfer Equipment (Horizontal Use) ..	B 15-69
• Vertical Conveyance System	B 15-83
Options	B 15-95
Contaminaton Protection	B 15-96
Lubrication	B 15-97
Corrosion Resistance (Surface Treatment, etc.) ..	B 15-97
Contamination Protection Seal for Ball Screws ..	B 15-98
Wiper Ring W	B 15-99
Dust Cover for Ball Screws	B 15-101
QZ Lubricator	B 15-102
Mounting Procedure and Maintenance ..	B 15-104
Mounting Procedure	B 15-104
• Installing the Support Unit	B 15-104
• Installation onto the Table and the Base ..	B 15-104
• Checking the Accuracy and Fully Fastening the Support Unit ..	B 15-105
• Connection with the Motor	B 15-105
Maintenance Method	B 15-106
• Amount of Lubricant	B 15-106
Model No.	B 15-107
• Model Number Coding	B 15-107
• Notes on Ordering	B 15-111
Precautions on Use	B 15-112
Precautions on Using Options for the Ball Screw ..	B 15-114
• QZ Lubricator for the Ball Screw	B 15-114

Types of Ball Screws

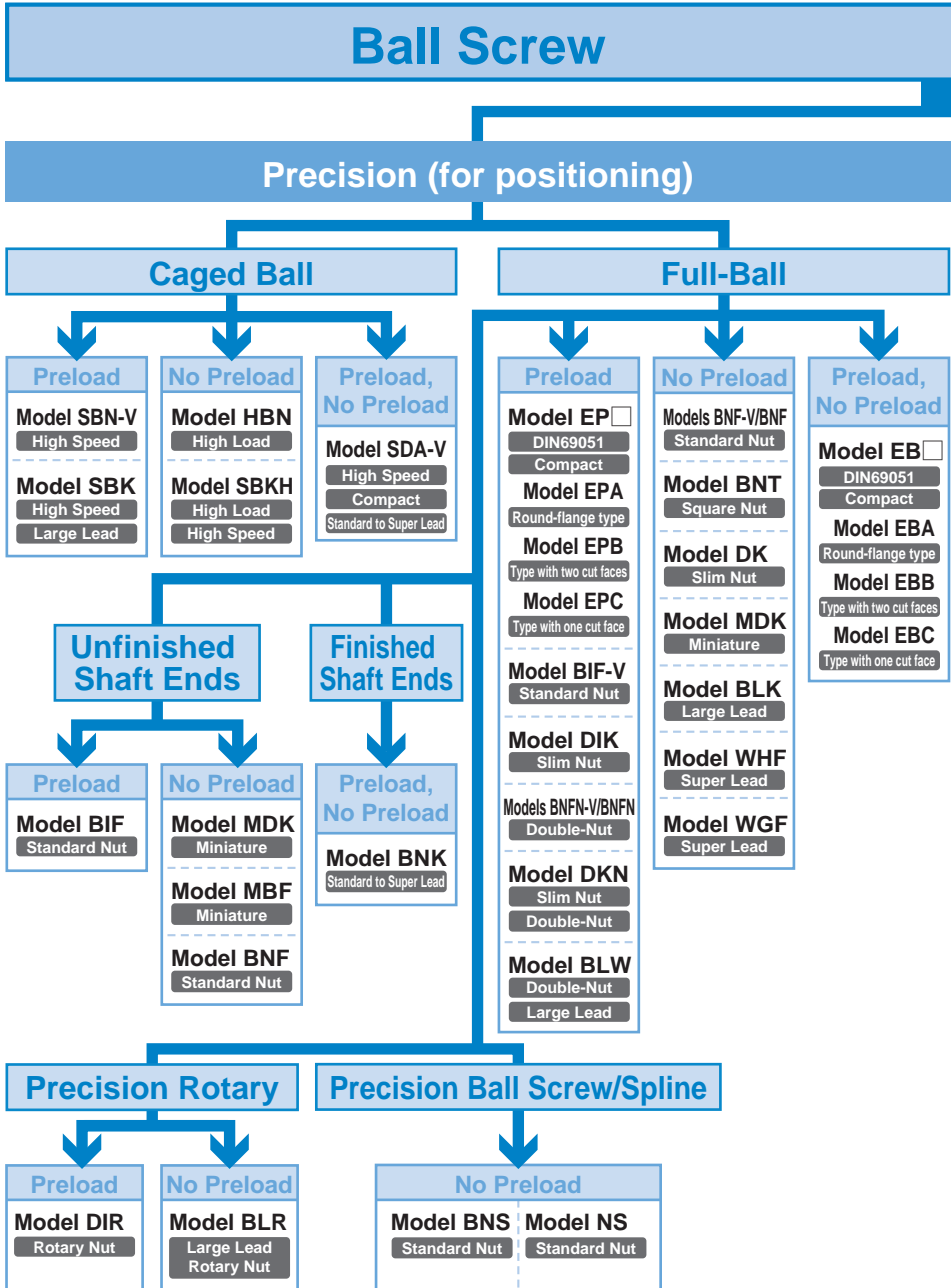

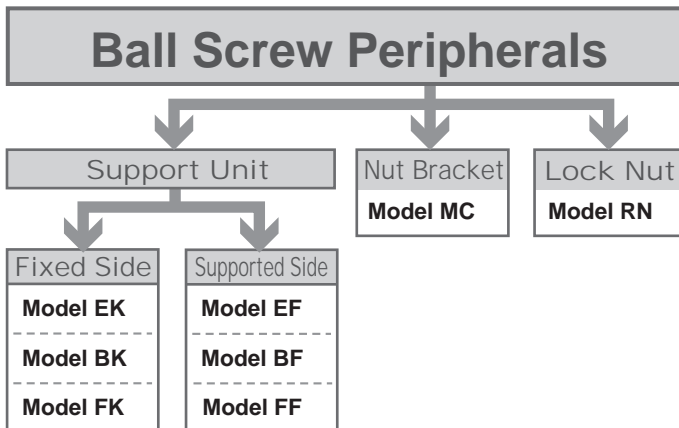
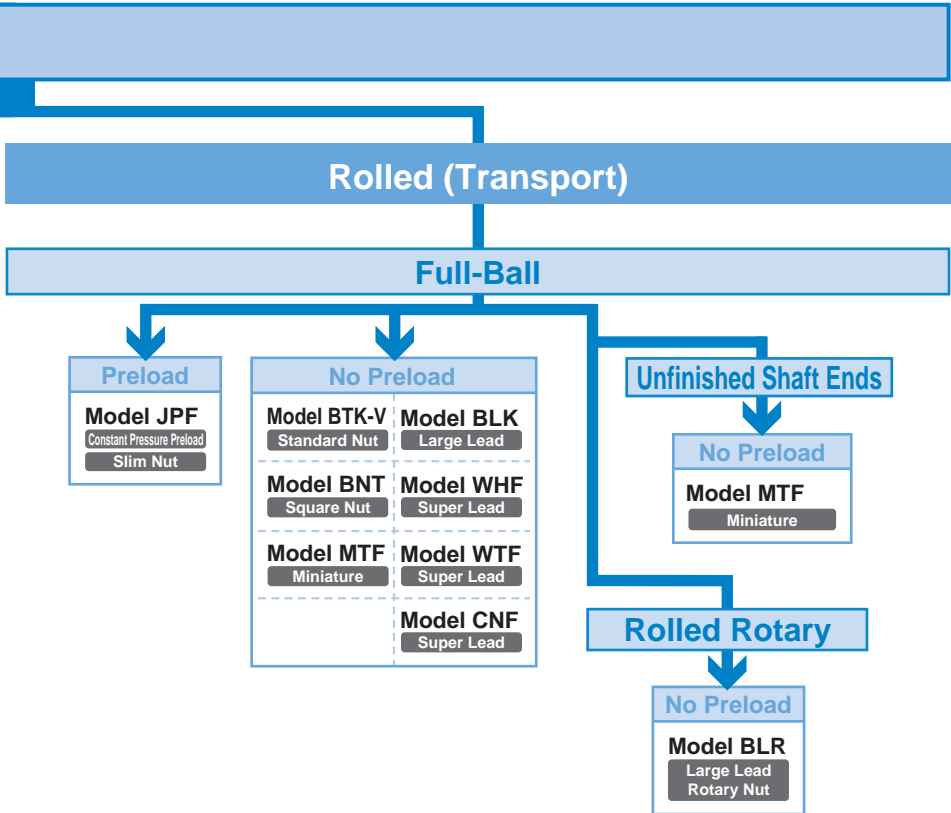

Flowchart for Selecting a Ball Screw

[Ball Screw Selection Procedure]

When selecting a Ball Screw, it is necessary to make a selection while considering various parameters. The following is a flowchart for selecting a Ball Screw.

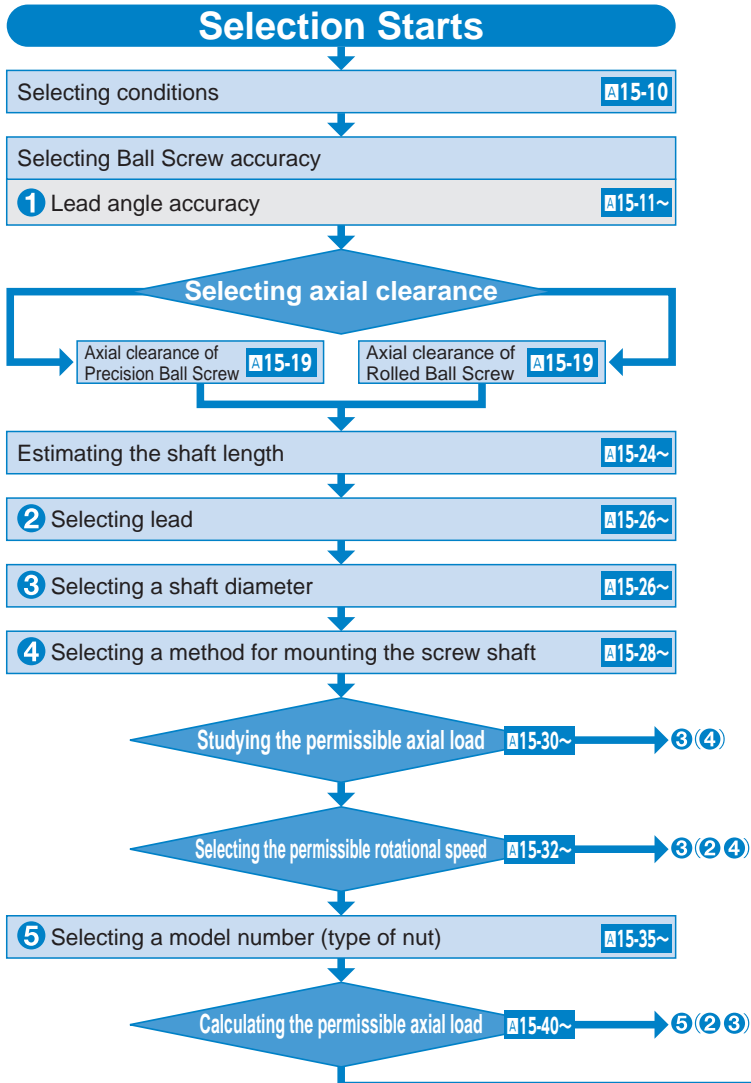

Point of Selection
Flowchart for Selecting a Ball Screw

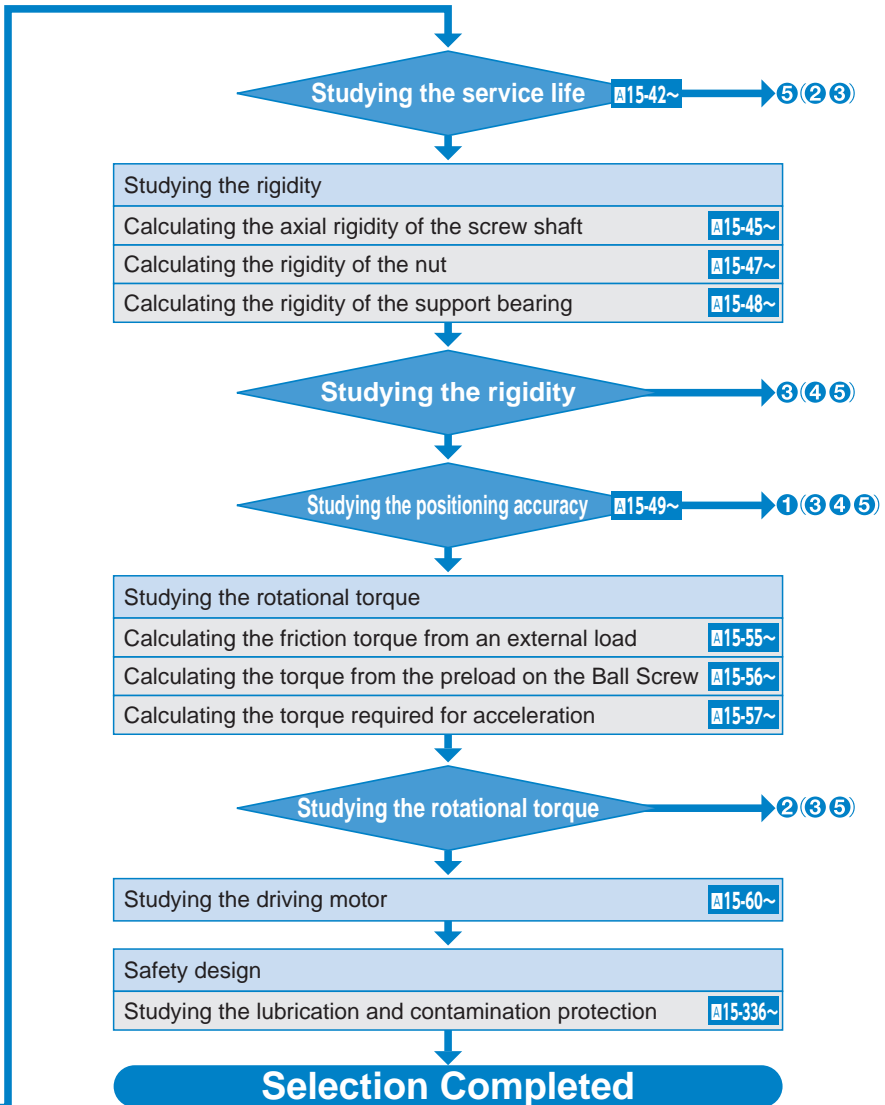

[Conditions of the Ball Screw]

The following conditions are required when selecting a Ball Screw.

Transfer orientation (horizontal, vertical, etc.)
 Transferred mass m (kg)
 Table guide method (sliding, rolling)
 Frictional coefficient of the guide surface μ (—)
 Guide surface resistance f (N)
 External load in the axial direction F (N)
 Desired service life time L_h (h)

Stroke length l_s (mm)
 Operating speed V_{max} (m/s)
 Acceleration time t_1 (s)
 Even speed time t_2 (s)
 Deceleration time t_3 (s)

Acceleration $\alpha = \frac{V_{max}}{t_1}$ (m/s²)

Acceleration distance $l_1 = V_{max} \times t_1 \times 1000/2$ (mm)

Even speed distance $l_2 = V_{max} \times t_2 \times 1000$ (mm)

Deceleration distance $l_3 = V_{max} \times t_3 \times 1000/2$ (mm)

Number of reciprocations per minute n (min⁻¹)

Positioning accuracy (mm)

Positioning accuracy repeatability (mm)

Backlash (mm)

Minimum feed amount s (mm/pulse)

Driving motor (AC servomotor, stepping motor, etc.)

The rated rotation speed of the motor N_{MO} (min⁻¹)

Inertial moment of the motor J_M (kg·m²)

Motor resolution (pulse/rev)

Reduction ratio A (—)

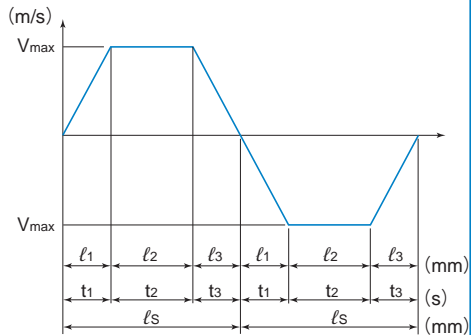

Accuracy of the Ball Screw

Lead Angle Accuracy

The accuracy of the Ball Screw in the lead angle is controlled in accordance with the JIS standards (JIS B 1192 - 1997).

Accuracy grades C0 to C5 are defined in the linearity and the directional property, and C7 to C10 in the travel distance error in relation to 300 mm.

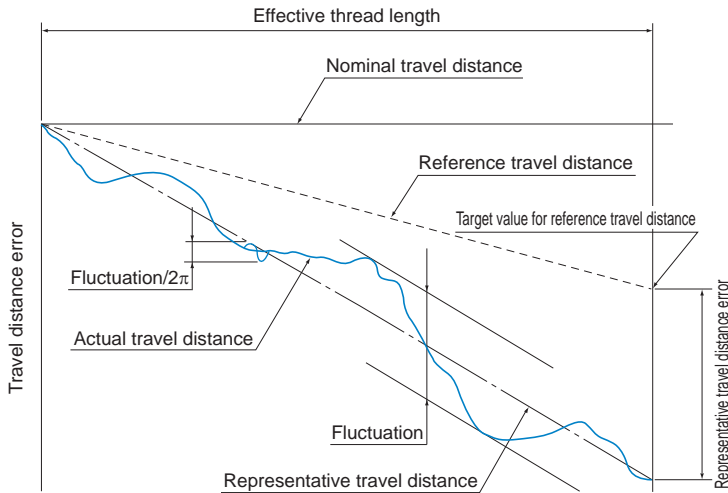

Fig.1 Terms on Lead Angle Accuracy

[Actual Travel Distance]

An error in the travel distance measured with an actual Ball Screw.

[Reference Travel Distance]

Generally, it is the same as nominal travel distance, but can be an intentionally corrected value of the nominal travel distance according to the intended use.

[Target Value for Reference Travel Distance]

You may provide some tension in order to prevent the screw shaft from runout, or set the reference travel distance in “negative” or “positive” value in advance given the possible expansion/contraction from external load or temperature. In such cases, indicate a target value for the reference travel distance.

[Representative Travel Distance]

It is a straight line representing the tendency in the actual travel distance, and obtained with the least squares method from the curve that indicates the actual travel distance.

[Representative Travel Distance Error (in \pm)]

Difference between the representative travel distance and the reference travel distance.

[Fluctuation]

The maximum width of the actual travel distance between two straight lines drawn in parallel with the representative travel distance.

[Fluctuation/300]

Indicates a fluctuation against a given thread length of 300 mm.

[Fluctuation/2 π]

A fluctuation in one revolution of the screw shaft.

Table1 Lead Angle Accuracy (Permissible Value)

Unit: μm

Accuracy grades		Precision Ball Screw										Rolled Ball Screw		
		C0		C1		C2		C3		C5		C7	C8	C10
Effective thread length		Representative travel distance error	Fluctuation	Representative travel distance error	Fluctuation	Representative travel distance error	Fluctuation	Representative travel distance error	Fluctuation	Representative travel distance error	Fluctuation	Travel distance error	Travel distance error	Travel distance error
Above	Or less													
—	100	3	3	3.5	5	5	7	8	8	18	18	±50/ 300mm	±100/ 300mm	±210/ 300mm
100	200	3.5	3	4.5	5	7	7	10	8	20	18			
200	315	4	3.5	6	5	8	7	12	8	23	18			
315	400	5	3.5	7	5	9	7	13	10	25	20			
400	500	6	4	8	5	10	7	15	10	27	20			
500	630	6	4	9	6	11	8	16	12	30	23			
630	800	7	5	10	7	13	9	18	13	35	25			
800	1000	8	6	11	8	15	10	21	15	40	27			
1000	1250	9	6	13	9	18	11	24	16	46	30			
1250	1600	11	7	15	10	21	13	29	18	54	35			
1600	2000	—	—	18	11	25	15	35	21	65	40			
2000	2500	—	—	22	13	30	18	41	24	77	46			
2500	3150	—	—	26	15	36	21	50	29	93	54			
3150	4000	—	—	30	18	44	25	60	35	115	65			
4000	5000	—	—	—	—	52	30	72	41	140	77			
5000	6300	—	—	—	—	65	36	90	50	170	93			
6300	8000	—	—	—	—	—	—	110	60	210	115			
8000	10000	—	—	—	—	—	—	—	—	260	140			

Note) Unit of effective thread length: mm

Table2 Fluctuation in Thread Length of 300 mm and in One Revolution (permissible value)

Unit: μm

Accuracy grades	C0	C1	C2	C3	C5	C7	C8	C10
Fluctuation/300	3.5	5	7	8	18	—	—	—
Fluctuation/ 2π	3	4	5	6	8	—	—	—

Table3 Types and Grades

Type	Series symbol	Grade	Remarks
For positioning	Cp	1, 3, 5	ISO compliant
For transport	Ct	1, 3, 5, 7, 10	

Note) Accuracy grades apply also to the Cp series and Ct series. Contact THK for details.

Example: When the lead of a Ball Screw manufactured is measured with a target value for the reference travel distance of $-9\ \mu\text{m}/500\ \text{mm}$, the following data are obtained.

Table4 Measurement Data on Travel Distance Error

Unit: mm

Command position (A)	0	50	100	150
Travel distance (B)	0	49.998	100.001	149.996
Travel distance error (A-B)	0	-0.002	+0.001	-0.004

Command position (A)	200	250	300	350
Travel distance (B)	199.995	249.993	299.989	349.985
Travel distance error (A-B)	-0.005	-0.007	-0.011	-0.015

Command position (A)	400	450	500
Travel distance (B)	399.983	449.981	499.984
Travel distance error (A-B)	-0.017	-0.019	-0.016

The measurement data are expressed in a graph as shown in Fig.2.

The positioning error (A-B) is indicated as the actual travel distance while the straight line representing the tendency of the (A-B) graph refers to the representative travel distance.

The difference between the reference travel distance and the representative travel distance appears as the representative travel distance error.

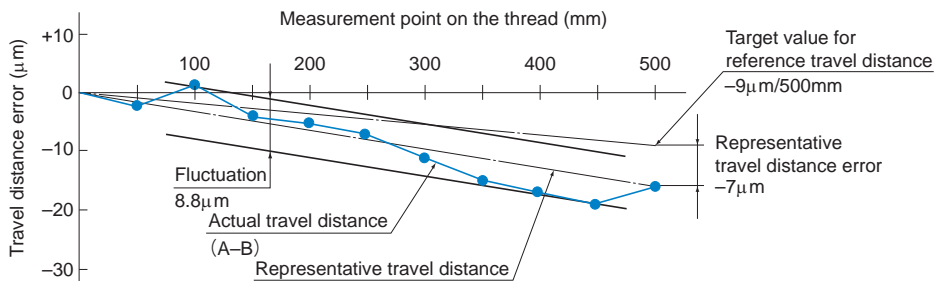

Fig.2 Measurement Data on Travel Distance Error

[Measurements]

Representative travel distance error: $-7\ \mu\text{m}$

Fluctuation: $8.8\ \mu\text{m}$

[Accuracy Standards for the Mounting Surface]

Table5 to Table9 show accuracy standards for the mounting surfaces of the precision Ball Screw.

Table5 Radial Runout of the Circumference of the Thread Root in Relation to the Supporting Portion Axis of the Screw Shaft
Unit: μm

Screw shaft outer diameter (mm)		Runout (maximum)					
Above	Or less	C0	C1	C2	C3	C5	C7
—	8	3	5	7	8	10	14
8	12	4	5	7	8	11	14
12	20	4	6	8	9	12	14
20	32	5	7	9	10	13	20
32	50	6	8	10	12	15	20
50	80	7	9	11	13	17	20
80	100	—	10	12	15	20	30

Note) The measurements on these items include the effect of the runout of the screw shaft diameter. Therefore, it is necessary to obtain the correction value from the overall runout of the screw shaft axis, using the ratio of the distance between the fulcrum and measurement point to the overall screw shaft length, and add the obtained value to the table above.

Example: model No. DIK2005-6RRGO+500LC5

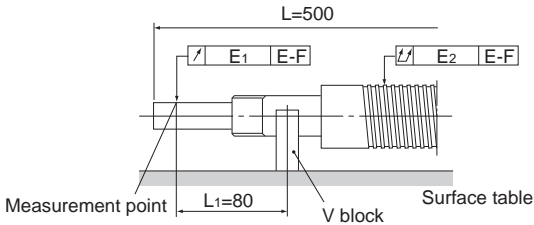

$$E_1 = e + \Delta e$$

e : Standard value in Table5(0.012)

Δe : Correction value

$$\Delta e = \frac{L_1}{L} \times E_2$$

$$= \frac{80}{500} \times 0.06$$

$$= 0.01$$

L : Overall screw shaft length

L_1 : Distance between the fulcrum and the measurement point

E_2 : Overall radial runout of the screw shaft axis (0.06)

$$E_1 = 0.012 + 0.01$$

$$= 0.022$$

Note) For the overall radial runout of the screw shaft axis, refer to JIS B 1192-1997.

Table6 Perpendicularity of the Supporting Portion End of the Screw Shaft to the Supporting Portion Axis

Unit: μm

Screw shaft outer diameter (mm)		Perpendicularity (maximum)					
Above	Or less	C0	C1	C2	C3	C5	C7
—	8	2	3	3	4	5	7
8	12	2	3	3	4	5	7
12	20	2	3	3	4	5	7
20	32	2	3	3	4	5	7
32	50	2	3	3	4	5	8
50	80	3	4	4	5	7	10
80	100	—	4	5	6	8	11

Table7 Perpendicularity of the Flange Mounting Surface of the Screw Shaft to the Screw Shaft Axis

Unit: μm

Nut diameter (mm)		Perpendicularity (maximum)					
Above	Or less	C0	C1	C2	C3	C5	C7
—	20	5	6	7	8	10	14
20	32	5	6	7	8	10	14
32	50	6	7	8	8	11	18
50	80	7	8	9	10	13	18
80	125	7	9	10	12	15	20
125	160	8	10	11	13	17	20
160	200	—	11	12	14	18	25

Table8 Radial Runout of the Nut Circumference in Relation to the Screw Shaft Axis

Unit: μm

Nut diameter (mm)		Runout (maximum)					
Above	Or less	C0	C1	C2	C3	C5	C7
—	20	5	6	7	9	12	20
20	32	6	7	8	10	12	20
32	50	7	8	10	12	15	30
50	80	8	10	12	15	19	30
80	125	9	12	16	20	27	40
125	160	10	13	17	22	30	40
160	200	—	16	20	25	34	50

Table9 Parallelism of the Nut Circumference (Flat Mounting Surface) to the Screw Shaft Axis

Unit: μm

Mounting reference length (mm)		Parallelism (maximum)					
Above	Or less	C0	C1	C2	C3	C5	C7
—	50	5	6	7	8	10	17
50	100	7	8	9	10	13	17
100	200	—	10	11	13	17	30

[Method for Measuring Accuracy of the Mounting Surface]

● Radial Runout of the Circumference of the Motor-mounting Shaft-end in Relation to the Bearing Journals of the Screw Shaft (see Table5 on **A15-15**)

Support the end journal of the screw shaft on V blocks. Place a probe on the circumference of the motor-mounting shaft-end, and record the largest difference on the dial gauge as a measurement while rotating the screw shaft through one revolution.

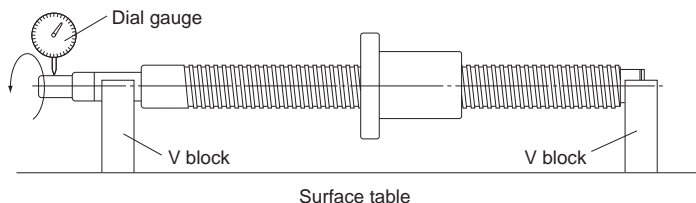

● **Radial Runout of the Circumference of the Raceway Threads in Relation to the Bearing Journals of the Screw Shaft (see Table5 on A15-15)**

Support the end journal of the screw shaft on V blocks. Place a probe on the circumference of the nut, and record the largest difference on the dial gauge as a measurement while rotating the screw shaft by one revolution without rotating the nut.

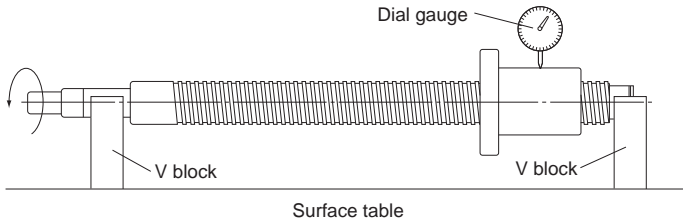

● **Perpendicularity of the End Journal of the Screw Shaft to the Bearing Journals (see Table6 on A15-16)**

Support the bearing journal portions of the screw shaft on V blocks. Place a probe on the screw shaft's supporting portion end, and record the largest difference on the dial gauge as a measurement while rotating the screw shaft through one revolution.

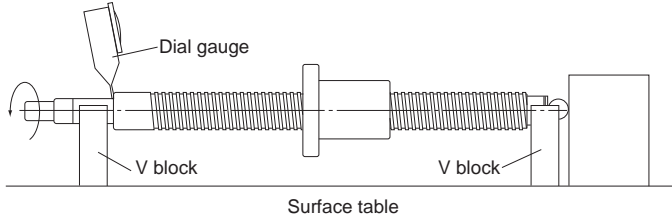

● **Perpendicularity of the Flange Mounting Surface of the Screw Shaft to the Bearing Journals (see Table7 on A15-16)**

Support the thread of the screw shaft on V blocks near the nut. Place a probe on the flange end, and record the largest difference on the dial gauge as a measurement while simultaneously rotating the screw shaft and the nut through one revolution.

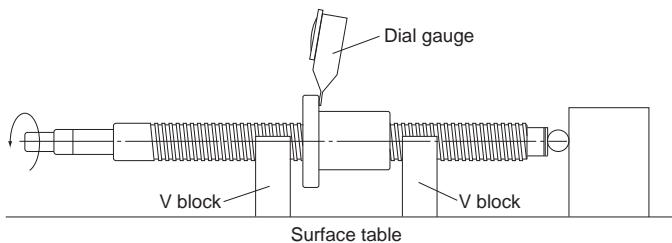

● **Radial Runout of the Nut Circumference in Relation to the Screw Shaft Axis (see Table 8 on A15-16)**

Support the thread of the screw shaft on V blocks near the nut. Place a probe on the circumference of the nut, and record the largest difference on the dial gauge as a measurement while rotating the nut through one revolution without rotating the screw shaft.

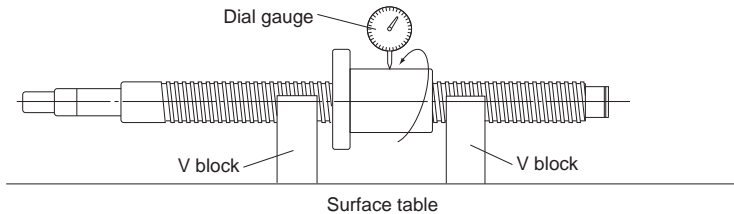

● **Parallelism of the Nut Circumference (Flat Mounting Surface) to the Screw Shaft Axis (see Table 9 on A15-16)**

Support the thread of the screw shaft on V blocks near the nut. Place a probe on the circumference of the nut (flat mounting surface), and record the largest difference on the dial gauge as a measurement while moving the dial gauge in parallel with the screw shaft.

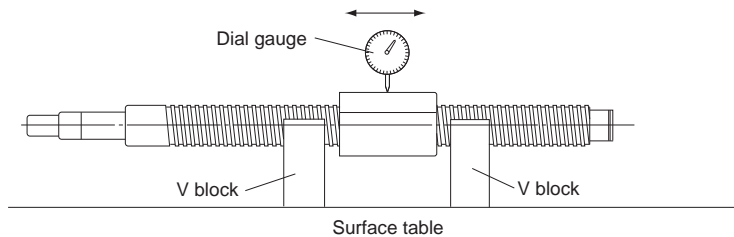

● **Overall Radial Runout of the Screw Shaft Axis**

Support the supporting portion of the screw shaft on V blocks. Place a probe on the circumference of the screw shaft, and record the largest difference on the dial gauge at several points in the axial directions as a measurement while rotating the screw shaft through one revolution.

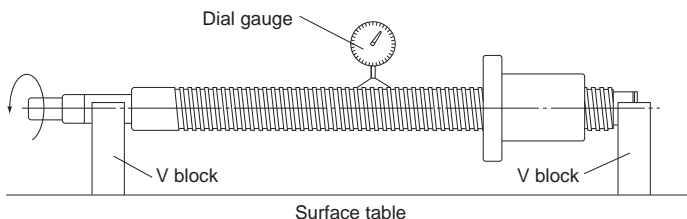

Note) For the overall radial runout of the screw shaft axis, refer to JIS B 1192-1997.

Axial Clearance

[Axial Clearance of the Precision Ball Screw]

Table10 shows the axial clearance of the precision Screw Ball. If the manufacturing length exceeds the value in Table11, the resultant clearance may partially be negative (preload applied).

The manufacturing limit lengths of the Ball Screws compliant with the DIN standard are provided in Table12.

For the axial clearance of the Precision Caged Ball Screw, see **A15-72** to **A15-89**.

Table10 Axial Clearance of the Precision Ball Screw

Unit: mm

Clearance symbol	G0	GT	G1	G2	G3
Axial Clearance	0 or less	0 to 0.005	0 to 0.01	0 to 0.02	0 to 0.05

Table11 Maximum Length of the Precision Ball Screw in Axial Clearance

Unit: mm

Screw shaft outer diameter	Clearance GT				Clearance G1				Clearance G2						
	C0	C1	C2•C3	C5	C0	C1	C2•C3	C5	C0	C1	C2	C3	C5	C7	
4•6	80	80	80	100	80	80	80	100	80	80	80	80	100	120	
8	230	250	250	200	230	250	250	250	230	250	250	250	300	300	
10	250	250	250	200	250	250	250	250	250	250	250	250	300	300	
12•13	440	500	500	400	440	500	500	500	440	500	630	680	600	500	
14	500	500	500	400	500	500	500	500	530	620	700	700	600	500	
15	500	500	500	400	500	500	500	500	570	670	700	700	600	500	
16	500	500	500	400	500	500	500	500	620	700	700	700	600	500	
18	720	800	800	700	720	800	800	700	720	840	1000	1000	1000	1000	
20	800	800	800	700	800	800	800	700	820	950	1000	1000	1000	1000	
25	800	800	800	700	800	800	800	700	1000	1000	1000	1000	1000	1000	
28	900	900	900	800	1100	1100	1100	900	1300	1400	1400	1400	1200	1200	
30•32	900	900	900	800	1100	1100	1100	900	1400	1400	1400	1400	1400	1200	
36•40•45	1000	1000	1000	800	1300	1300	1300	1000	2000	2000	2000	2000	1500	1500	
50•55•63•70	1200	1200	1200	1000	1600	1600	1600	1300	2000	2500	2500	2500	2000	2000	
80•100	—	—	—	—	1800	1800	1800	1500	2000	4000	4000	4000	3000	3000	

*When manufacturing the Ball Screw of precision-grade accuracy C7 with clearance GT or G1, the resultant clearance is partially negative.

Table12 Manufacturing limit lengths of precision Ball Screws with axial clearances (DIN standard compliant Ball Screws)

Unit: mm

Shaft diameter	Clearance GT		Clearance G1		Clearance G2		
	C3, Cp3	C5, Cp5, Ct5	C3, Cp3	C5, Cp5, Ct5	C3, Cp3	C5, Cp5, Ct5	C7, Cp7
16	500	400	500	500	700	600	500
20, 25	800	700	800	700	1000	1000	1000
32	900	800	1100	900	1400	1200	1200
40	1000	800	1300	1000	2000	1500	1500
50, 63	1200	1000	1600	1300	2500	2000	2000

*When manufacturing the Ball Screw of precision-grade accuracy C7 (Ct7) with clearance GT or G1, the resultant clearance is partially negative.

[Axial Clearance of the Rolled Ball Screw]

Table13 shows axial clearance of the rolled Ball Screw.

Table13 Axial Clearance of the Rolled Ball Screw

Unit: mm

Screw shaft outer diameter	Axial clearance (maximum)
6 to 12	0.05
14 to 28	0.1
30 to 32	0.14
36 to 45	0.17
50	0.2

Preload

A preload is provided in order to eliminate the axial clearance and minimize the displacement under an axial load.

When performing a highly accurate positioning, a preload is generally provided.

[Rigidity of the Ball Screw under a Preload]

When a preload is provided to the Ball Screw, the rigidity of the nut is increased.

Fig.4 shows elastic displacement curves of the Ball Screw under a preload and without a preload.

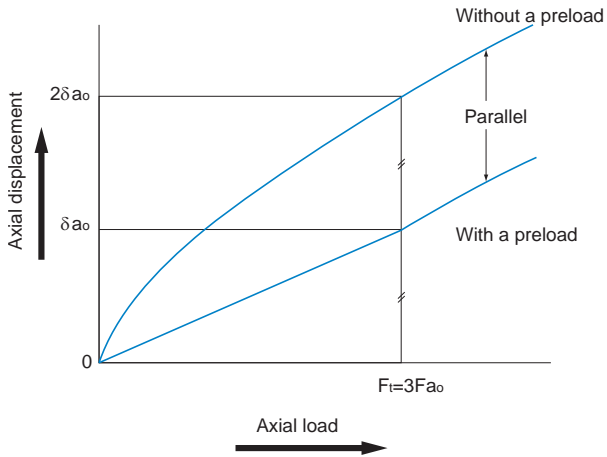
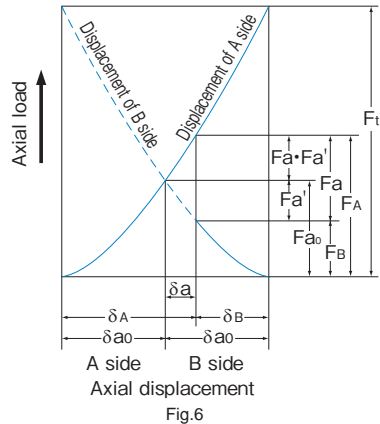
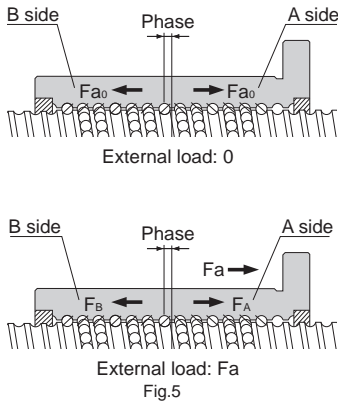

Fig.4 Elastic Displacement Curve of the Ball Screw

Fig.5 shows a single-nut type of the Ball Screw.



The A and B sides are provided with preload F_{a0} by changing the groove pitch in the center of the nut to create a phase. Because of the preload, the A and B sides are elastically displaced by δ_{a0} each. If an axial load (F_a) is applied from outside in this state, the displacement of the A and B sides is calculated as follows.

$$\delta_A = \delta_{a0} + \delta a \quad \delta_B = \delta_{a0} - \delta a$$

In other words, the loads on the A and B sides are expressed as follows:

$$F_A = F_{a0} + (F_a - F_{a'}) \quad F_B = F_{a0} - F_{a'}$$

Therefore, under a preload, the load that the A side receives equals to $F_a - F_{a'}$. This means that since load $F_{a'}$, which is applied when the A side receives no preload, is deducted from F_a , the displacement of the A side is smaller.

This effect extends to the point where the displacement (δ_{a0}) caused by the preload applied on the B side reaches zero.

To what extent is the elastic displacement reduced? The relationship between the axial load on the Ball Screw under no preload and the elastic displacement can be expressed by $\delta_a \propto F_a^{2/3}$. From Fig.6, the following equations are established.

$$\delta_{a0} = K F_{a0}^{2/3} \quad (K : \text{constant})$$

$$2\delta_{a0} = K F_t^{2/3}$$

$$\left(\frac{F_t}{F_{a0}}\right)^{2/3} = 2 \quad F_t = 2^{3/2} \times F_{a0} = 2.8F_{a0} \doteq 3F_{a0}$$

Thus, the Ball Screw under a preload is displaced by δ_{a0} when an axial load (F_t) approximately three times greater than the preload is provided from outside. As a result, the displacement of the Ball Screw under a preload is half the displacement ($2\delta_{a0}$) of the Ball Screw without a preload.

As stated above, since the preloading is effective up to approximately three times the applied preload, the optimum preload is one third of the maximum axial load.

Note that an excessive preload adversely affects the service life and heat generation. The maximum preload should be set at 10% of the basic dynamic load rating (C_a) in the axial direction.

[Preload Torque]

The preload torque of the Ball Screw in lead is controlled in accordance with the JIS standard (JIS B 1192-1997).

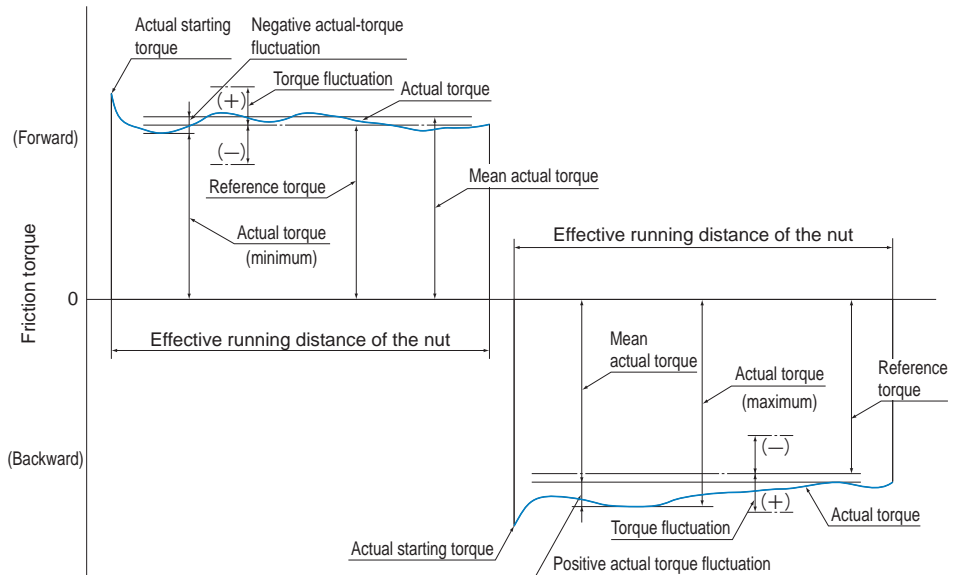

Fig.7 Terms on Preload Torque

● Dynamic Preload Torque

A torque required to continuously rotate the screw shaft of a Ball Screw under a given preload without an external load applied.

● Actual Torque

A dynamic preload torque measured with an actual Ball Screw.

● Torque Fluctuation

Variation in a dynamic preload torque set at a target value. It can be positive or negative in relation to the reference torque.

● Coefficient of Torque Fluctuation

Ratio of torque fluctuation to the reference torque.

● Reference Torque

A dynamic preload torque set as a target.

● Calculating the Reference Torque

The reference torque of a Ball Screw provided with a preload is obtained in the following equation (4).

$$T_p = 0.05 (\tan\beta)^{-0.5} \frac{F_{a0} \cdot Ph}{2\pi} \dots\dots\dots (4)$$

T_p : Reference torque (N-mm)

β : Lead angle

F_{a0} : Applied preload (N)

Ph : Lead (mm)

Point of Selection

Accuracy of the Ball Screw

Example: When a preload of 3,000 N is provided to the Ball Screw model BIF4010-10G0 + 1500LC3 with a thread length of 1,300 mm (shaft diameter: 40 mm; ball center-to-center diameter: 41.75 mm; lead: 10 mm), the preload torque of the Ball Screw is calculated in the steps below.

■Calculating the Reference Torque

β : Lead angle

$$\tan\beta = \frac{\text{lead}}{\pi \times \text{ball center-to-center diameter}} = \frac{10}{\pi \times 41.75} = 0.0762$$

F_{a_0} : Applied preload=3000N

Ph : Lead = 10mm

$$T_p = 0.05 (\tan\beta)^{-0.5} \frac{F_{a_0} \cdot Ph}{2\pi} = 0.05 (0.0762)^{-0.5} \frac{3000 \times 10}{2\pi} = 865\text{N} \cdot \text{mm}$$

■Calculating the Torque Fluctuation

$$\frac{\text{thread length}}{\text{screw shaft outer diameter}} = \frac{1300}{40} = 32.5 \leq 40$$

Thus, with the reference torque in Table14 being between 600 and 1,000 N•mm, effective thread length 4,000 mm or less and accuracy grade C3, the coefficient of torque fluctuation is obtained as $\pm 30\%$.

As a result, the torque fluctuation is calculated as follows.

$$865 \times (1 \pm 0.3) = 606 \text{ N} \cdot \text{mm} \text{ to } 1125 \text{ N} \cdot \text{mm}$$

■Result

Reference torque : 865 N•mm

Torque fluctuation : 606 N•mm to 1125 N•mm

Table14 Tolerance Range in Torque Fluctuation

Reference torque N•mm		Effective thread length												
		4000mm or less											Above 4,000 mm and 10,000 mm or less	
		$\frac{\text{thread length}}{\text{screw shaft outer diameter}} \leq 40$						$40 < \frac{\text{thread length}}{\text{screw shaft outer diameter}} < 60$					—	
		Accuracy grades						Accuracy grades					Accuracy grades	
Above	Or less	C0	C1	C3	C5	C7	C0	C1	C3	C5	C7	C3	C5	C7
200	400	±30%	±35%	±40%	±50%	—	±40%	±40%	±50%	±60%	—	—	—	—
400	600	±25%	±30%	±35%	±40%	—	±35%	±35%	±40%	±45%	—	—	—	—
600	1000	±20%	±25%	±30%	±35%	±40%	±30%	±30%	±35%	±40%	±45%	±40%	±45%	±50%
1000	2500	±15%	±20%	±25%	±30%	±35%	±25%	±25%	±30%	±35%	±40%	±35%	±40%	±45%
2500	6300	±10%	±15%	±20%	±25%	±30%	±20%	±20%	±25%	±30%	±35%	±30%	±35%	±40%
6300	10000	—	±15%	±15%	±20%	±30%	—	—	±20%	±25%	±35%	±25%	±30%	±35%

Selecting a Screw Shaft

Maximum Length of the Screw Shaft

Table15 shows the manufacturing limit lengths of precision Ball Screws by accuracy grades, Table16 shows the manufacturing limit lengths of precision Ball Screws compliant with DIN standard by accuracy grades, and Table17 shows the manufacturing limit lengths of rolled Ball Screws by accuracy grades.

If the shaft dimensions exceed the manufacturing limit in Table15, Table16 or Table17, contact THK.

Table15 Maximum Length of the Precision Ball Screw by Accuracy Grade

Unit: mm

Screw shaft outer diameter	Overall screw shaft length						
	C0	C1	C2	C3	C5	C7	
4	90	110	120	120	120	120	
6	150	170	210	210	210	210	
8	230	270	340	340	340	340	
10	350	400	500	500	500	500	
12	440	500	630	680	680	680	
13	440	500	630	680	680	680	
14	530	620	770	870	890	890	
15	570	670	830	950	980	1100	
16	620	730	900	1050	1100	1400	
18	720	840	1050	1220	1350	1600	
20	820	950	1200	1400	1600	1800	
25	1100	1400	1600	1800	2000	2400	
28	1300	1600	1900	2100	2350	2700	
30	1450	1700	2050	2300	2570	2950	
32	1600	1800	2200	2500	2800	3200	
36	2000	2100	2550	2950	3250	3650	
40		2400	2900	3400	3700	4300	
45		2750	3350	3950	4350	5050	
50		3100	3800	4500	5000	5800	
55		3450	4150	5300	6050	6500	
63		4000	6300	5200	5800	6700	7700
70				6450	7650	9000	10000
80				7900	9000	10000	
100				10000	10000		

Point of Selection

Selecting a Screw Shaft

Table16 Manufacturing limit lengths of precision Ball Screws (DIN standard compliant Ball Screws)

Unit: mm

Shaft diameter	Ground shaft			CES shaft			
	C3	C5	C7	Cp3	Cp5	Ct5	Ct7
16	1050	1100	1400	1050	1100	1100	1400
20	1400	1600	1800	1400	1600	1600	1800
25	1800	2000	2400	1800	2000	2000	2400
32	2500	2800	3200	2500	2800	2800	3200
40	3400	3700	4300	3400	3700	3700	4300
50	4500	5000	5800	—	—	—	—
63	5800	6700	7700	—	—	—	—

Table17 Maximum Length of the Rolled Ball Screw by Accuracy Grade

Unit: mm

Screw shaft outer diameter	Overall screw shaft length		
	C7	C8	C10
6 to 8	320	320	—
10 to 12	500	1000	—
14 to 15	1500	1500	1500
16 to 18	1500	1800	1800
20	2000	2200	2200
25	2000	3000	3000
28	3000	3000	3000
30	3000	3000	4000
32 to 36	3000	4000	4000
40	3000	5000	5000
45	3000	5500	5500
50	3000	6000	6000

Standard Combinations of Shaft Diameter and Lead for the Precision Ball Screw

Table18 shows standard combinations of shaft diameters and leads of precision Ball Screws, and Table19 shows standard combinations of shaft diameters and leads of precision Ball Screws compliant with DIN standard.

For standard combinations of shaft diameter and lead of the Precision Caged Ball Screw, see **A15-72** to **A15-89**.

If a Ball Screw not covered by the table is required, contact THK.

Table18 Standard Combinations of Screw Shaft and Lead (Precision Ball Screw)

Unit: mm

Screw shaft outer diameter	Lead																						
	1	2	4	5	6	8	10	12	15	16	20	24	25	30	32	36	40	50	60	80	90	100	
4	●																						
5	●																						
6	●																						
8	●	●					●	○															
10		●	●				●		○														
12		●		●			●																
13														○									
14		●	●	●			●																
15							●				●			○			○						
16			○	●	○		○			●													
18							●																
20			○	●	○	○	●	○			●						○		○				
25			○	●	○	○	●	○		○	●		○					○					
28				○	●	○	○																
30																			○			○	
32			○	●	●	○	●	○			○					○							
36					○	○	●	○		○	○	○					○						
40				○	○	○	●	●		○	○			○			○				○		
45					○	○	○	○		○	○												
50					○		○	●		○	○				○		○		○				○
55							○	○		○	○				○		○		○				
63							○	○		○	○												
70							○	○			○												
80							○	○			○												
100											○												
120																							

●: Standardized Screw Shafts (Unfinished Shaft Ends/Finished Shaft Ends)

○: Semi-standard stock

Table19 Standard combinations of outer diameters and leads of the screw shafts (DIN standard compliant Ball Screws)

Unit: mm

Shaft diameter	Lead		
	5	10	20
16	●	—	—
20	●	—	—
25	●	●	—
32	●	●	—
40	○	●	○*
50	—	○	○*
63	—	○	○*

●: Ground shaft, CES shaft

○: Ground shaft only

*: Model EB (no preload) only

Standard Combinations of Shaft Diameter and Lead for the Rolled Ball Screw

Table20 shows the standard combinations of shaft diameter and lead for the rolled Ball Screw.

Table20 Standard Combinations of Screw Shaft and Lead (Rolled Ball Screw)

Unit: mm

Screw shaft outer diameter	Lead																			
	1	2	4	5	6	8	10	12	16	20	24	25	30	32	36	40	50	60	80	100
6	●																			
8		●																		
10		●			○															
12		●				○														
14			●	●																
15							●		●		●									
16				●					●											
18						●														
20				●			●		●							●				
25				●			●					●					●			
28					●															
30																	●			
32							●						●							
36							●		●	●				●						
40							●									●			●	
45								●												
50									●								●			●

●: Standard stock

○: Semi-standard stock

Method for Mounting the Ball Screw Shaft

Fig.8 to Fig.11 show the representative mounting methods for the screw shaft.

The permissible axial load and the permissible rotational speed vary with mounting methods for the screw shaft. Therefore, it is necessary to select an appropriate mounting method according to the conditions.

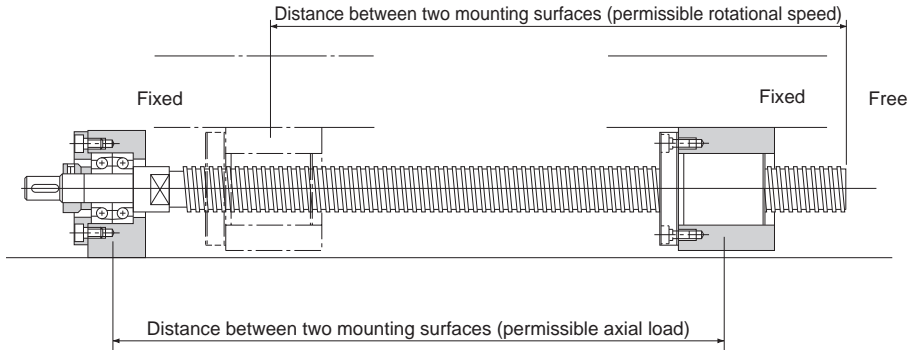

Fig.8 Screw Shaft Mounting Method: Fixed - Free

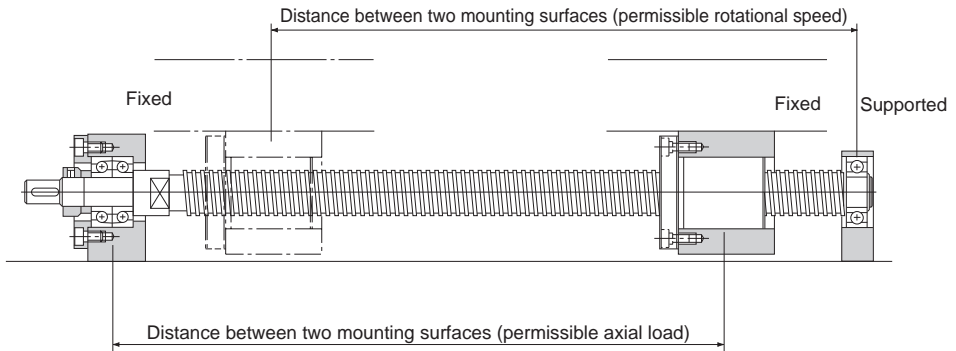

Fig.9 Screw Shaft Mounting Method: Fixed - Supported

Point of Selection

Method for Mounting the Ball Screw Shaft

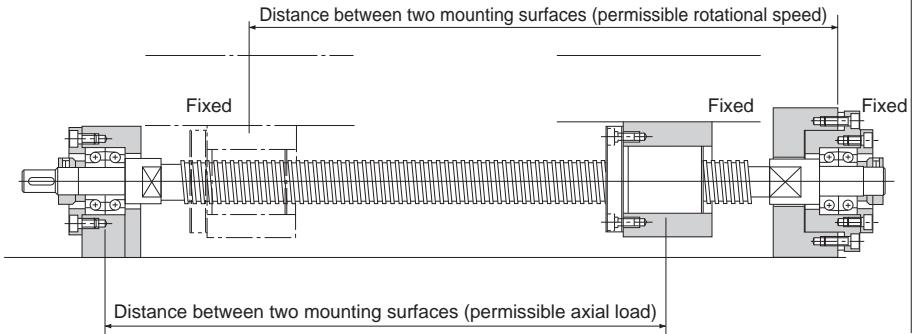

Fig.10 Screw Shaft Mounting Method: Fixed - Fixed

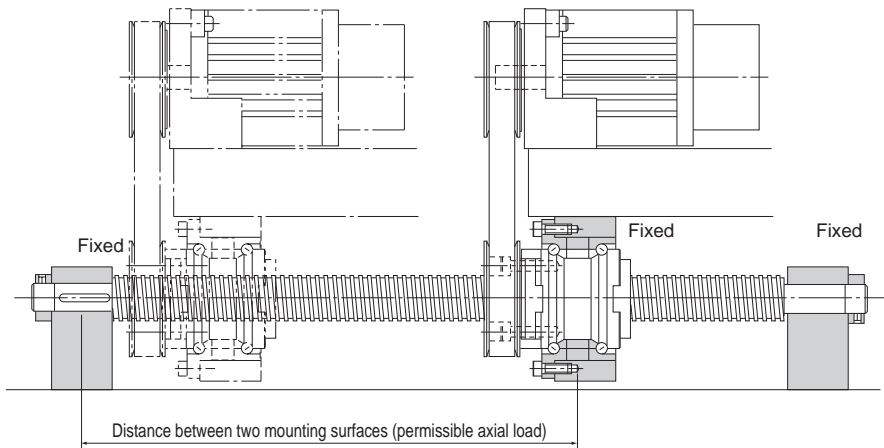

Fig.11 Screw Shaft Mounting Method for Rotary Nut Ball Screw: Fixed - Fixed

Permissible Axial Load

[Buckling Load on the Screw Shaft]

With the Ball Screw, it is necessary to select a screw shaft so that it will not buckle when the maximum compressive load is applied in the axial direction.

Fig.12 on **A15-31** shows the relationship between the screw shaft diameter and a buckling load.

If determining a buckling load by calculation, it can be obtained from the equation (5) below. Note that in this equation, a safety factor of 0.5 is multiplied to the result.

$$P_1 = \frac{\eta_1 \cdot \pi^2 \cdot E \cdot I}{\ell_a^2} \cdot 0.5 = \eta_2 \frac{d_1^4}{\ell_a^2} \cdot 10^4 \quad \dots\dots\dots(5)$$

P_1 : Buckling load (N)

ℓ_a : Distance between two mounting surfaces (mm)

E : Young's modulus (2.06×10^5 N/mm²)

I : Minimum geometrical moment of inertia of the shaft (mm⁴)

$$I = \frac{\pi}{64} d_1^4 \quad d_1: \text{screw-shaft thread minor diameter (mm)}$$

η_1, η_2 =Factor according to the mounting method

Fixed - free $\eta_1=0.25$ $\eta_2=1.3$

Fixed - supported $\eta_1=2$ $\eta_2=10$

Fixed - fixed $\eta_1=4$ $\eta_2=20$

[Permissible Tensile Compressive Load on the Screw Shaft]

If an axial load is applied to the Ball Screw, it is necessary to take into account not only the buckling load but also the permissible tensile compressive load in relation to the yielding stress on the screw shaft.

The permissible tensile compressive load is obtained from the equation (6).

$$P_2 = \sigma \frac{\pi}{4} d_1^2 = 116d_1^2 \quad \dots\dots\dots(6)$$

P_2 : Permissible tensile compressive load (N)

σ : Permissible tensile compressive stress (147 MPa)

d_1 : Screw-shaft thread minor diameter (mm)

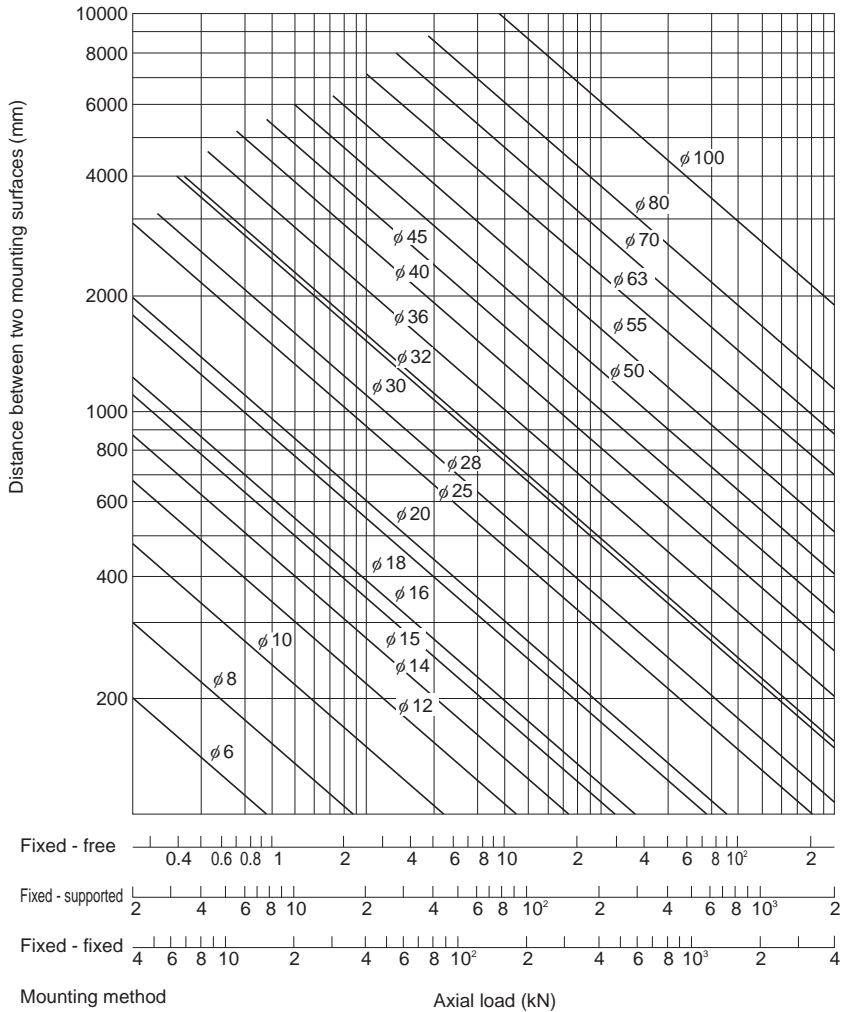

Fig.12 Permissible Tensile Compressive Load Diagram

Permissible Rotational Speed

[Dangerous Speed of the Screw Shaft]

When the rotational speed reaches a high magnitude, the Ball Screw may resonate and eventually become unable to operate due to the screw shaft's natural frequency. Therefore, it is necessary to select a model so that it is used below the resonance point (dangerous speed).

Fig.13 on **A15-34** shows the relationship between the screw shaft diameter and a dangerous speed.

If determining a dangerous speed by calculation, it can be obtained from the equation (7) below. Note that in this equation, a safety factor of 0.8 is multiplied to the result.

$$N_1 = \frac{60 \cdot \lambda_1^2}{2\pi \cdot \ell_b^2} \times \sqrt{\frac{E \times 10^3 \cdot I}{\gamma \cdot A}} \times 0.8 = \lambda_2 \cdot \frac{d_1}{\ell_b^2} \cdot 10^7 \dots\dots(7)$$

N_1 : Permissible rotational speed determined
by dangerous speed (min⁻¹)

ℓ_b : Distance between two mounting surfaces
(mm)

E : Young's modulus (2.06 × 10⁵ N/mm²)

I : Minimum geometrical moment of inertia
of the shaft (mm⁴)

$$I = \frac{\pi}{64} d_1^4 \quad d_1: \text{screw-shaft thread minor diameter (mm)}$$

γ : Density (specific gravity)
(7.85 × 10⁶kg/mm³)

A : Screw shaft cross-sectional area (mm²)

$$A = \frac{\pi}{4} d_1^2$$

λ_1, λ_2 : Factor according to the mounting method

Fixed - free $\lambda_1=1.875$ $\lambda_2=3.4$

Supported - supported $\lambda_1=3.142$ $\lambda_2=9.7$

Fixed - supported $\lambda_1=3.927$ $\lambda_2=15.1$

Fixed - fixed $\lambda_1=4.73$ $\lambda_2=21.9$

Point of Selection

Permissible Rotational Speed

[DN Value]

The permissible rotational speed of the Ball Screw must be obtained from the dangerous speed of the screw shaft and the DN value.

The permissible rotational speed determined by the DN value is obtained using the equations (8) to (16) below.

Precision	Caged Ball	Large Lead	Model SBK (SBK3636, SBK4040 and SBK5050)	$N_2 = \frac{210000}{D}$(8-1)
			Model SBK (Other than the above model numbers and the small size model SBK*)	$N_2 = \frac{160000}{D}$(8-2)
		Standard lead	Model SBN-V (Medium)	$N_2 = \frac{160000}{D}$(9-1)
			Models SBN-V (Small), HBN, and SBKH	$N_2 = \frac{130000}{D}$(9-2)
	Full- Complement Ball	Super Lead	Model WHF	$N_2 = \frac{120000}{D}$(10-1)
			Model WGF	$N_2 = \frac{70000}{D}$(10-2)
		Large Lead	Models BLW, BLK, BLR, BNS and NS	$N_2 = \frac{70000}{D}$(11)
			Standard lead	Models BIF-V (Medium), BNFN-V (Medium), and BNF (Medium)
		Models BIF-V (Small), BNFN-V (Small), and BNF (Small)		$N_2 = \frac{100000}{D}$(12-2)
		Models BIF, DIK, BNFN, DKN, BNF, BNT, DK, MDK, MBF, BNK and DIR	$N_2 = \frac{70000}{D}$(12-3)	
Full-Complement Ball (DIN Standard Compliant)	Standard lead	Models EBA, EBB, EBC, EPA, EPB and EPC	$N_2 = \frac{100000}{D}$(13)	
Rolled	Full- Complement Ball	Super Lead	Model WHF	$N_2 = \frac{100000}{D}$(14-1)
			Models WTF and CNF	$N_2 = \frac{70000}{D}$(14-2)
		Large Lead	Models BLK and BLR	$N_2 = \frac{70000}{D}$(15)
		Standard lead	Model BTK-V	$N_2 = \frac{100000}{D}$(16-1)
			Models JPF, BNT and MTF	$N_2 = \frac{50000}{D}$(16-2)

N_2 : Permissible rotational speed determined by the DN value (min⁻¹(rpm))

D : Ball center-to-center diameter

(indicated in the specification tables of the respective model number)

Of the permissible rotational speed determined by dangerous speed (N_1) and the permissible rotational speed determined by DN value (N_2), the lower rotational speed is regarded as the permissible rotational speed.

For small size SBK (SBK1520 to 3232) and SDA, the permissible rotational speed (N_2) is the maximum permissible rotational speed shown in the dimensional tables.(See dimensional tables on pages **A15-76** to **A15-77**, and **A15-80** to **A15-85**)

If the service rotational speed exceeds N_2 , contact THK.

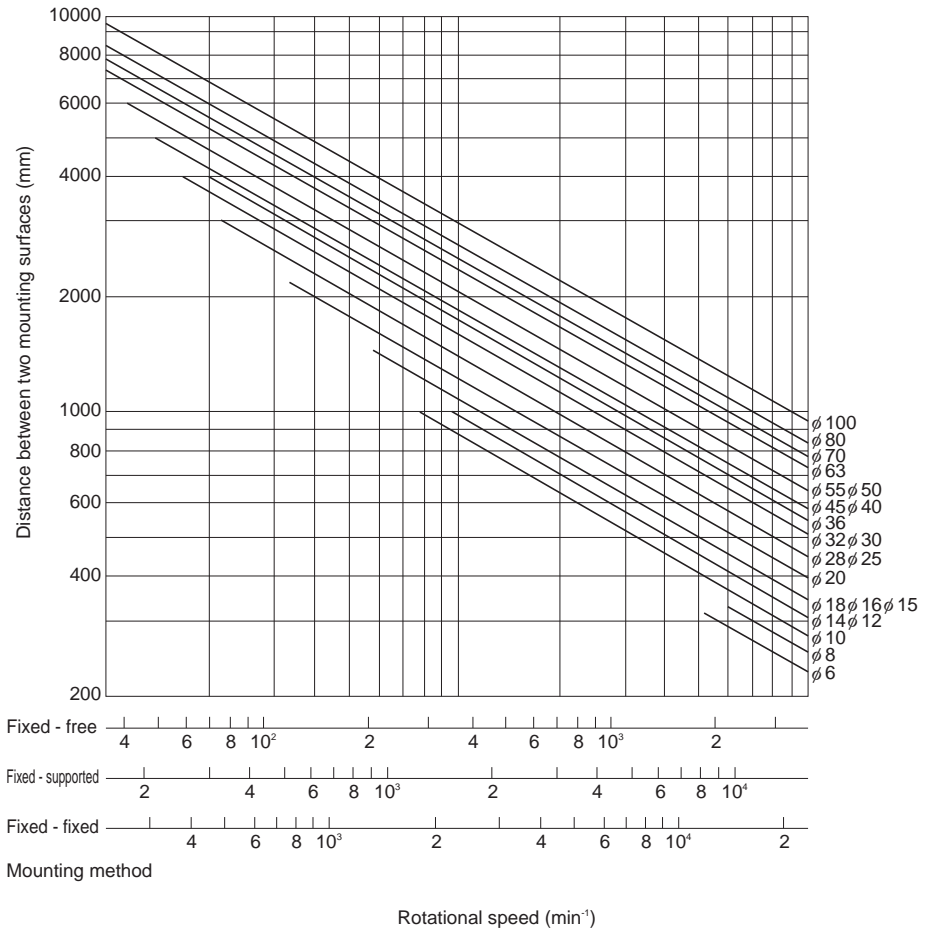

Fig.13 Permissible Rotational Speed Diagram

Selecting a Nut

Types of Nuts

The nuts of the Ball Screws are categorized by the ball circulation method into the return-pipe type, the deflector type and end cap type. These three nut types are described as follows.

In addition to the circulation methods, the Ball Screws are categorized also by the preloading method.

[Types by Ball Circulation Method]

- **Return-Pipe Type**
(Models SBN-V (Medium), BIF-V (Medium), BIF, BNF-V (Medium), BNF, BNFN-V (Medium), BNFN, BNT, BTK-V),
Return-Piece Type
(Models SBN-V (Small), HBN, BIF-V (Small), BNF-V (Small), BNFN-V (Small))

These are most common types of nuts that use a return pipe for ball circulation. The return pipe allows balls to be picked up, pass through the pipe, and return to their original positions to complete infinite motion.

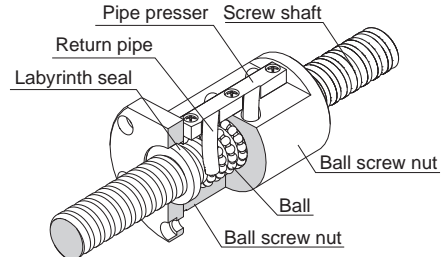

Example of Structure of Return-Pipe Nut

- **Deflector Type**
(Models EB, EP, DK, DKN, DIK, JPF, DIR and MDK)

These are the most compact type of nut. The balls change their traveling direction with a deflector, pass over the circumference of the screw shaft, and return to their original positions to complete an infinite motion.

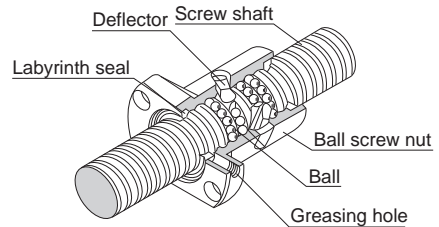

Example of Structure of Simple Nut

- **End-cap Type: Large lead Nut**
(Models SBK, SBKH, WHF, BLK, WGF, BLW, WTF, CNF and BLR)

These nuts are most suitable for the fast feed. The balls are picked up with an end cap, pass through the through hole of the nut, and return to their original positions to complete an infinite motion.

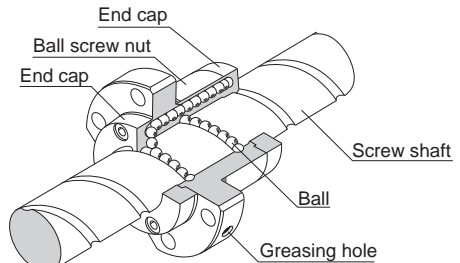

Example of Structure of Large lead Nut

[Types by Preloading Method]

● Fixed-point Preloading

■ Double-nut Preload (Models BNFN-V, BNFN, DKN and BLW)

A spacer is inserted between two nuts to provide a preload.

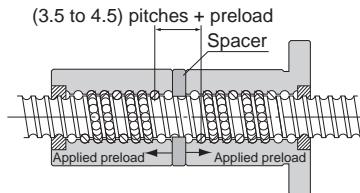

Models BNFN-V and BNFN



Model DKN



Model BLW

■ Offset Preload (Models SBN-V, EP, BIF-V, BIF, DIK, DIR and SBK)

More compact than the double-nut method, the offset preloading provides a preload by changing the groove pitch of the nut without using a spacer.

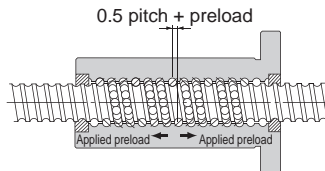

Model SBN-V



Models BIF-V and BIF



Model DIK



Model EPB



Model DIR



Model SBK

Point of Selection

Selecting a Nut

● Constant Pressure Preloading (Model JPF)

With this method, a spring structure is installed almost in the middle of the nut, and it provides a preload by changing the groove pitch in the middle of the nut.

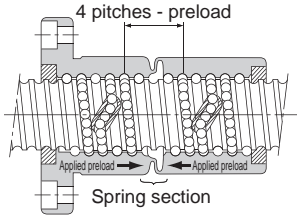

Model JPF

[Structure and Features of Offset Preload Type Simple-Nut Ball Screw]

The Simple-Nut Ball Screw is an offset preload type in which a phase is provided in the middle of a single ball screw nut, and an axial clearance is set at a below-zero value (under a preload).

The Simple-Nut Ball Screw has a more compact structure and allows smoother motion than the conventional double-nut type (spacer inserted between two nuts).

[Comparison between the Simple Nut and the Double-Nuts]

Simple-Nut Ball Screw	Conventional Double-Nut Type Ball Screw
<p>Ball screw nut</p>	<p>Ball screw nut Ball screw nut Spacer</p>
Preloading Structure	
<p>Applied preload Applied preload</p> <p>Pitch (Pitch + preload) Pitch</p> <p>Ball screw nut</p> <p>Pitch Pitch Pitch</p> <p>Screw shaft</p>	<p>Applied preload Applied preload</p> <p>Pitch (4 to 5 pitches + preload) Pitch</p> <p>Ball screw nut Spacer Ball screw nut</p> <p>Pitch Pitch Pitch Pitch Pitch</p> <p>Screw shaft</p>

Simple-Nut Ball Screw

Conventional Double-Nut Type Ball Screw

Rotational Performance

The preload adjustment with Simple Nut Ball Screw is performed according to the ball diameter. This eliminates the inconsistency in the contact angle, which is the most important factor of the Ball Screw performance. It also ensures the high rigidity, the smooth motion and the high wobbling accuracy.

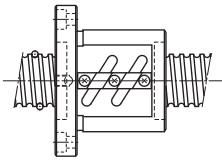

The use of a spacer in the double-nuts tends to cause inconsistency in the contact angle due to inaccurate flatness of the spacer surface and an inaccurate perpendicularity of the nut. This results in a non-uniform ball contact, an inferior rotational performance and a low wobbling accuracy.

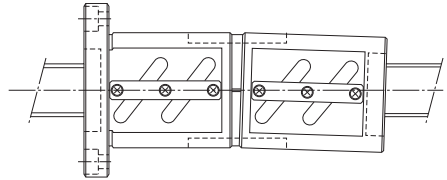

Dimensions

Since Simple-Nut Ball Screw is based on a preloading mechanism that does not require a spacer, the overall nut length can be kept short. As a result, the whole nut can be lightly and compactly designed.

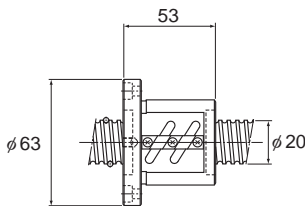

Simple-Nut

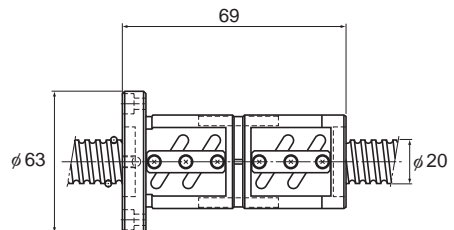

Double-Nut

[Comparison between the Offset Preload Type of Simple-Nut Ball Screw and the Oversized-ball Preload Nut Ball Screw]

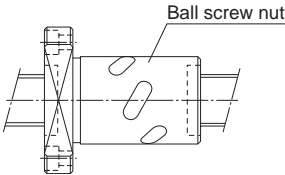
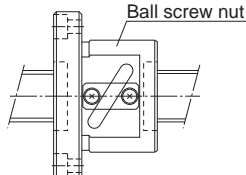
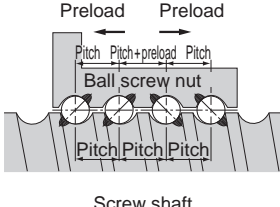
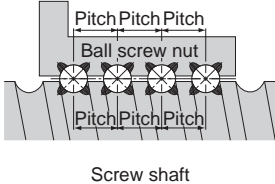
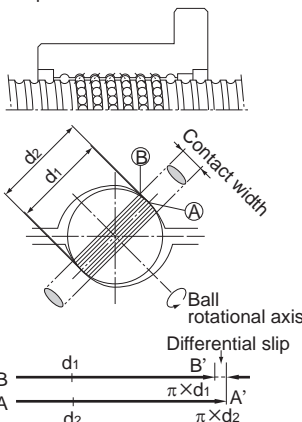
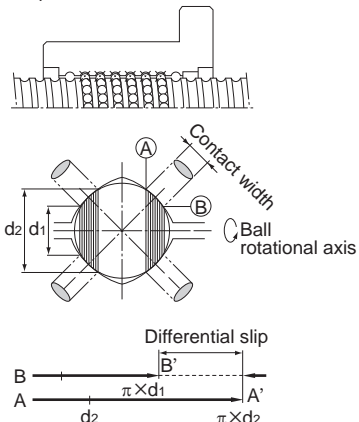
Simple-Nut Ball Screw Model DIK	Conventional Oversized-ball Preload Nut Ball Screw Model BNF
	
Preloading Structure	
	
Accuracy Life	
<p>Simple-Nut Ball Screw model DIK has a similar preloading structure to that of the double-nut type although the former only has one ball screw nut. As a result, no differential slip or spin occurs, thus minimizing the increase in the rotational torque and the generation of heat. Accordingly, a high level of accuracy can be maintained over a long period.</p> <p style="text-align: center;">2 point contact structure</p> 	<p>With the oversized-ball preload nut ball Screw, a preload is provided through each of the balls in contact with the raceway at four points. This causes differential slip and spin increasing the rotational torque, resulting in accelerated wear and heat generation. Therefore, the accuracy deteriorates in a short period.</p> <p style="text-align: center;">4 point contact structure</p> 

Selecting a Model Number

Calculating the Axial Load

[In Horizontal Mount]

With ordinary conveyance systems, the axial load (F_{a_n}) applied when horizontally reciprocating the work is obtained in the equation below.

$$F_{a_1} = \mu \cdot mg + f + m\alpha \quad \dots\dots\dots (17)$$

$$F_{a_2} = \mu \cdot mg + f \quad \dots\dots\dots (18)$$

$$F_{a_3} = \mu \cdot mg + f - m\alpha \quad \dots\dots\dots (19)$$

$$F_{a_4} = -\mu \cdot mg - f - m\alpha \quad \dots\dots\dots (20)$$

$$F_{a_5} = -\mu \cdot mg - f \quad \dots\dots\dots (21)$$

$$F_{a_6} = -\mu \cdot mg - f + m\alpha \quad \dots\dots\dots (22)$$

V_{\max} : Maximum speed (m/s)

t_1 : Acceleration time (m/s)

$$\alpha = \frac{V_{\max}}{t_1} : \text{Acceleration} \quad (m/s^2)$$

F_{a_1} : Axial load during forward acceleration (N)

F_{a_2} : Axial load during forward uniform motion (N)

F_{a_3} : Axial load during forward deceleration (N)

F_{a_4} : Axial load during backward acceleration (N)

F_{a_5} : Axial load during uniform backward motion (N)

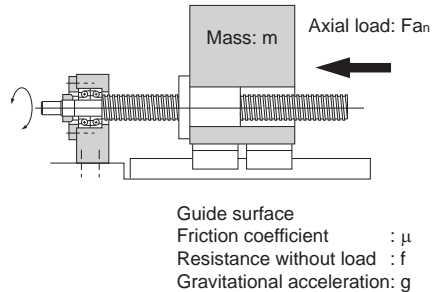

F_{a_6} : Axial load during backward deceleration (N)

m : Transferred mass (kg)

μ : Frictional coefficient of the guide surface (-)

f : Guide surface resistance (without load) (N)

[In Vertical Mount]

With ordinary conveyance systems, the axial load (F_{a_n}) applied when vertically reciprocating the work is obtained in the equation below.

$$F_{a_1} = mg + f + m\alpha \quad \dots\dots\dots (23)$$

$$F_{a_2} = mg + f \quad \dots\dots\dots (24)$$

$$F_{a_3} = mg + f - m\alpha \quad \dots\dots\dots (25)$$

$$F_{a_4} = mg - f - m\alpha \quad \dots\dots\dots (26)$$

$$F_{a_5} = mg - f \quad \dots\dots\dots (27)$$

$$F_{a_6} = mg - f + m\alpha \quad \dots\dots\dots (28)$$

V_{\max} : Maximum speed (m/s)

t_1 : Acceleration time (m/s)

$$\alpha = \frac{V_{\max}}{t_1} : \text{Acceleration} \quad (m/s^2)$$

F_{a_1} : Axial load during upward acceleration (N)

F_{a_2} : Axial load during uniform upward motion (N)

F_{a_3} : Axial load during upward deceleration (N)

F_{a_4} : Axial load during downward acceleration (N)

F_{a_5} : Axial load during uniform downward motion (N)

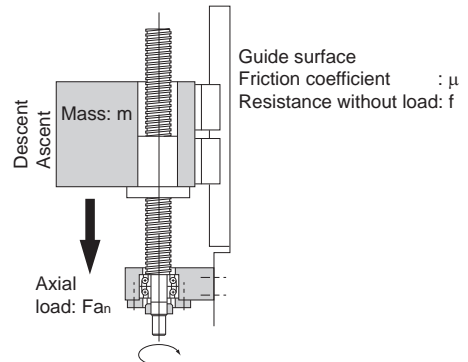

F_{a_6} : Axial load during downward deceleration (N)

m : Transferred mass (kg)

f : Guide surface resistance (without load) (N)

Static Safety Factor

The basic static load rating (C_{0a}) generally equals to the permissible axial load of a Ball Screw. Depending on the conditions, it is necessary to take into account the following static safety factor against the calculated load. When the Ball Screw is stationary or in motion, unexpected external force may be applied through an inertia caused by the impact or the start and stop.

$$F_{a_{\max}} = \frac{C_{0a}}{f_s} \dots\dots\dots(29)$$

$F_{a_{\max}}$: Allowable Axial Load (kN)

C_{0a} : Basic static load rating (kN)

f_s : Static safety factor (see Table21)

Table21 Static Safety Factor (f_s)

Machine using the LM system	Load conditions	Lower limit of f_s
General industrial machinery	Without vibration or impact	1.0 to 3.5
	With vibration or impact	2.0 to 5.0
Machine tool	Without vibration or impact	1.0 to 4.0
	With vibration or impact	2.5 to 7.0

*The basic static load rating (C_{0a}) is a static load with a constant direction and magnitude whereby the sum of the permanent deformation of the rolling element and that of the raceway on the contact area under the maximum stress is 0.0001 times the rolling element diameter. With the Ball Screw, it is defined as the axial load. (Specific values of each Ball Screw model are indicated in the specification tables for the corresponding model number.)

[Permissible Load Safety Margin (Models HBN and SBKH)]

High load Ball Screw model HBN and high-load high-speed Ball Screw model SBKH, in comparison to previous Ball Screws, are designed to achieve longer service lives under high load conditions, and for axial load it is necessary to consider the permissible load F_p .

Permissible load F_p indicates the maxim axial load that the high load Ball Screw can receive, and this range should not be exceeded.

$$\frac{F_p}{F_a} > 1 \dots\dots\dots(30)$$

F_p : Permissible Axial Load (kN)

F_a : Applied Axial Load (kN)

Studying the Service Life

[Service Life of the Ball Screw]

The Ball Screw in motion under an external load receives repeated stress on its raceways and balls. When the stress reaches the limit, the raceways break from fatigue and their surfaces flakes like scales. This phenomenon is called flaking. The service life of the Ball Screw is the total number of revolutions until the first flaking occurs on any of the raceways or the balls as a result of rolling fatigue of the material.

The service life of the Ball Screw varies from unit to unit even if they are manufactured in the same process and used in the same operating conditions. For this reason, when determining the service life of a Ball Screw unit, the nominal life as defined below is used as a guideline.

The nominal life is the total number of revolutions that 90% of identical Ball Screw units in a group achieve without developing flaking (scale-like pieces of a metal surface) after they independently operate in the same conditions.

[Calculating the Rated Life]

The service life of the Ball Screw is calculated from the equation (31) below using the basic dynamic load rating (Ca) and the applied axial load.

● Nominal Life (Total Number of Revolutions)

$$L = \left(\frac{C_a}{f_w \cdot F_a} \right)^3 \times 10^6 \quad \dots\dots\dots(31)$$

- L : Nominal life (total number of revolutions)
(rev)
- Ca : Basic dynamic load rating (N)
- Fa : Applied axial load (N)
- f_w : Load factor (see Table22)

Table22 Load Factor (f_w)

Vibrations/impact	Speed(V)	f _w
Faint	Very low V ≤ 0.25m/s	1 to 1.2
Weak	Slow 0.25 < V ≤ 1m/s	1.2 to 1.5
Medium	Medium 1 < V ≤ 2m/s	1.5 to 2
Strong	High V > 2m/s	2 to 3.5

*The basic dynamic load rating (Ca) is used in calculations of service life when the ball screw is under an axial load. The basic dynamic load rating is defined as a load rating based on the movement of a set of identical ball screws with a rated life (L) of 10⁶ revolutions, using a load applied in the axial direction that does not vary in either mass or direction. (The basic dynamic load ratings (Ca) for each model number are indicated in the specification tables.)

*The rated service life is estimated by calculating the load on the premise that the product is set up in ideal mounting conditions with the assurance of good lubrication. The service life can be affected by the precision of the mounting materials used and any distortion.

● Service Life Time

If the revolutions per minute is determined, the service life time can be calculated from the equation (32) below using the nominal life (L).

$$L_h = \frac{L}{60 \times N} = \frac{L \times Ph}{2 \times 60 \times n \times \ell_s} \quad \dots\dots\dots(32)$$

L_h	: Service life time	(h)
N	: Revolutions per minute	(min^{-1})
n	: Number of reciprocations per minute	(min^{-1})
Ph	: Ball Screw lead	(mm)
ℓ_s	: Stroke length	(mm)

● Service Life in Travel Distance

The service life in travel distance can be calculated from the equation (33) below using the nominal life (L) and the Ball Screw lead.

$$L_s = \frac{L \times Ph}{10^6} \quad \dots\dots\dots(33)$$

L_s	: Service Life in Travel Distance	(km)
Ph	: Ball Screw lead	(mm)

● Applied Load and Service Life with a Preload Taken into Account

If the Ball Screw is used under a preload (medium preload), it is necessary to consider the applied preload in calculating the service life since the ball screw nut already receives an internal load. For details on applied preload for a specific model number, contact THK.

● Average Axial Load

If an axial load acting on the Ball Screw is present, it is necessary to calculate the service life by determining the average axial load.

The average axial load (F_m) is a constant load that equals to the service life in fluctuating the load conditions.

If the load changes in steps, the average axial load can be obtained from the equation below.

$$F_m = \sqrt[3]{\frac{1}{\ell} (Fa_1^3 \ell_1 + Fa_2^3 \ell_2 + \dots + Fa_n^3 \ell_n)} \quad \dots\dots\dots(34)$$

F_m	: Average Axial Load	(N)
Fa_n	: Varying load	(N)
ℓ_n	: Distance traveled under load (F_n)	
ℓ	: Total travel distance	

To determine the average axial load using a rotational speed and time, instead of a distance, calculate the average axial load by determining the distance in the equation below.

$$l = l_1 + l_2 + \dots + l_n$$

$$l_1 = N_1 \cdot t_1$$

$$l_2 = N_2 \cdot t_2$$

$$l_n = N_n \cdot t_n$$

N: Rotational speed

t: Time

■When the Applied Load Sign Changes

If the sign (positive or negative) used for variable load is always the same, there are no problems with formula (34). However, if the variable load sign changes depending on the type of operation, calculate the average axial load for either positive or negative load, allowing for the load direction. (If the average axial load for positive load is calculated, the negative load is taken to be zero.) The larger of the two average axial loads is taken as the average axial load when the service life is calculated.

Example: Calculate the average axial load with the following load conditions.

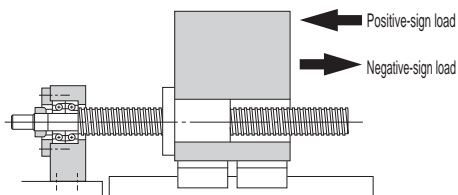

Operation No.	Varying load F_{a_i} (N)	Travel distance l_i (mm)
No.1	10	10
No.2	50	50
No.3	-40	10
No.4	-10	70

*The subscripts of the fluctuating load symbol and the travel distance symbol indicate operation numbers.

● Average axial load of positive-sign load

*To calculate the average axial load of the positive-sign load, assume F_{a_3} and F_{a_4} to be zero.

$$F_{m1} = \sqrt[3]{\frac{F_{a1}^3 \times l_1 + F_{a2}^3 \times l_2}{l_1 + l_2 + l_3 + l_4}} = 35.5\text{N}$$

● Average axial load of negative-sign load

*To calculate the average axial load of the negative-sign load, assume F_{a_1} and F_{a_2} to be zero.

$$F_{m2} = \sqrt[3]{\frac{|F_{a3}|^3 \times l_3 + |F_{a4}|^3 \times l_4}{l_1 + l_2 + l_3 + l_4}} = 17.2\text{N}$$

Accordingly, the average axial load of the positive-sign load (F_{m1}) is adopted as the average axial load (F_m) for calculating the service life.

Studying the Rigidity

To increase the positioning accuracy of feed screws in NC machine tools or the precision machines, or to reduce the displacement caused by the cutting force, it is necessary to design the rigidity of the components in a well-balanced manner.

Axial Rigidity of the Feed Screw System

When the axial rigidity of a feed screw system is K , the elastic displacement in the axial direction can be obtained using the equation (35) below.

$$\delta = \frac{Fa}{K} \dots\dots(35)$$

- δ : Elastic displacement of a feed screw system in the axial direction (μm)
 Fa : Applied axial load (N)

The axial rigidity (K) of the feed screw system is obtained using the equation (36) below.

$$\frac{1}{K} = \frac{1}{K_S} + \frac{1}{K_N} + \frac{1}{K_B} + \frac{1}{K_H} \dots\dots(36)$$

- K : Axial Rigidity of the Feed Screw System ($\text{N}/\mu\text{m}$)
 K_S : Axial rigidity of the screw shaft ($\text{N}/\mu\text{m}$)
 K_N : Axial rigidity of the nut ($\text{N}/\mu\text{m}$)
 K_B : Axial rigidity of the support bearing ($\text{N}/\mu\text{m}$)
 K_H : Rigidity of the nut bracket and the support bearing bracket ($\text{N}/\mu\text{m}$)

[Axial rigidity of the screw shaft]

The axial rigidity of a screw shaft varies depending on the method for mounting the shaft.

● For Fixed-Supported (or -Free) Configuration

$$K_S = \frac{A \cdot E}{1000 \cdot L} \dots\dots(37)$$

A : Screw shaft cross-sectional area (mm^2)

$$A = \frac{\pi}{4} d_1^2$$

- d_1 : Screw-shaft thread minor diameter (mm)
 E : Young's modulus ($2.06 \times 10^5 \text{ N}/\text{mm}^2$)
 L : Distance between two mounting surfaces (mm)

Fig.14 on **A15-46** shows an axial rigidity diagram for the screw shaft.

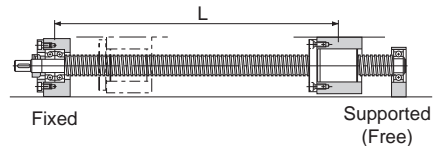

● For Fixed-Fixed Configuration

$$K_s = \frac{A \cdot E \cdot L}{1000 \cdot a \cdot b} \dots\dots(38)$$

K_s becomes the lowest and the elastic displacement in the axial direction is the greatest at the position of $a = b = \frac{L}{2}$.

$$K_s = \frac{4A \cdot E}{1000L}$$

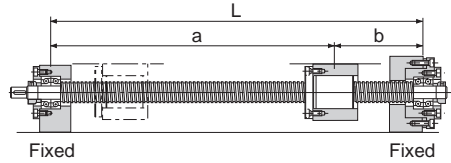

Fig.15 on **A15-47** shows an axial rigidity diagram of the screw shaft in this configuration.

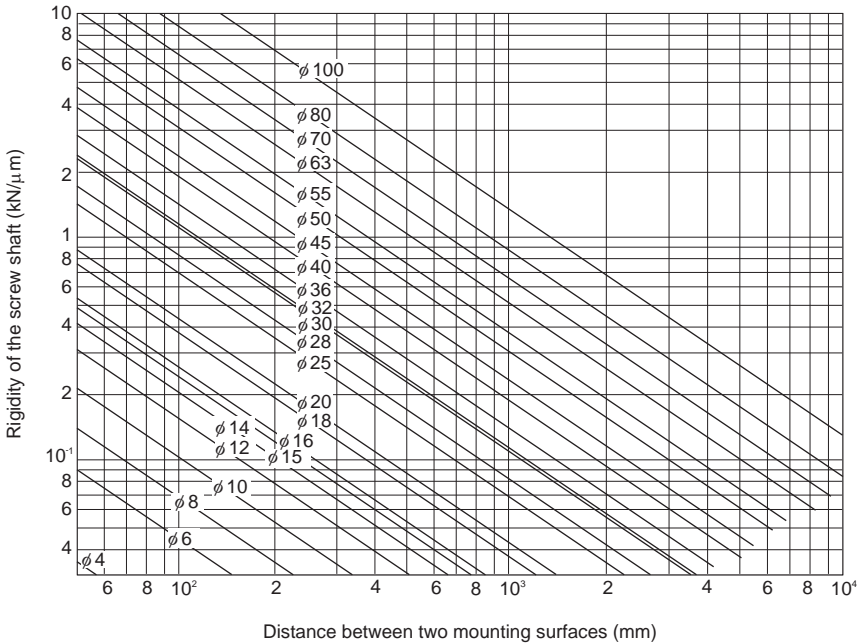

Fig.14 Axial Rigidity of the Screw Shaft (Fixed-Free, Fixed-Supported)

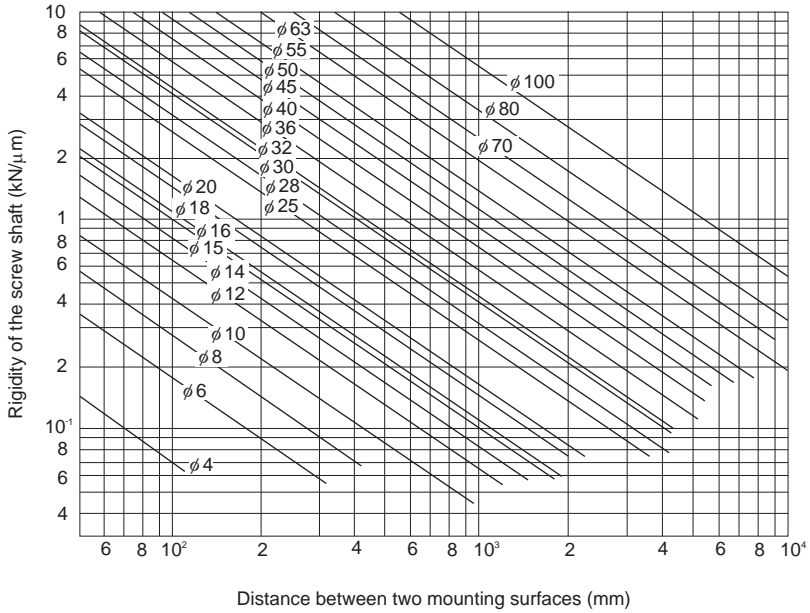

Fig.15 Axial Rigidity of the Screw Shaft (Fixed-Fixed)

[Axial rigidity of the nut]

The axial rigidity of the nut varies widely with preloads.

● No Preload Type

The logical rigidity in the axial direction when an axial load accounting for 30% of the basic dynamic load rating (C_a) is applied is indicated in the specification tables of the corresponding model number. This value does not include the rigidity of the components related to the nut-mounting bracket. In general, set the rigidity at roughly 80% of the value in the table.

The rigidity when the applied axial load is not 30% of the basic dynamic load rating (C_a) is calculated using the equation (39) below.

$$K_N = K \left(\frac{F_a}{0.3C_a} \right)^{\frac{1}{3}} \times 0.8 \quad \dots\dots(39)$$

K_N : Axial rigidity of the nut (N/μm)

K : Rigidity value in the specification tables (N/μm)

F_a : Applied axial load (N)

C_a : Basic dynamic load rating (N)

● Preload Type

The logical rigidity in the axial direction when an axial load accounting for 10% of the basic dynamic load rating (Ca) is applied is indicated in the dimensional table of the corresponding model number. This value does not include the rigidity of the components related to the nut-mounting bracket. In general, generally set the rigidity at roughly 80% of the value in the table.

The rigidity when the applied preload is not 10% of the basic dynamic load rating (Ca) is calculated using the equation (40) below.

$$K_N = K \left(\frac{Fa_0}{0.1Ca} \right)^{\frac{1}{3}} \times 0.8 \quad \dots\dots\dots(40)$$

K_N : Axial rigidity of the nut (N/μm)

K : Rigidity value in the specification tables (N/μm)

Fa_0 : Applied preload (N)

Ca : Basic dynamic load rating (N)

[Axial rigidity of the support bearing]

The rigidity of the Ball Screw support bearing varies depending on the support bearing used.

The calculation of the rigidity with a representative angular contact ball bearing is shown in the equation (41) below.

$$K_B \doteq \frac{3Fa_0}{\delta a_0} \quad \dots\dots\dots(41)$$

K_b : Axial rigidity of the support bearing (N/μm)

Fa_0 : Applied preload of the support bearing (N)

δa_0 : Axial displacements (μm)

$$\delta a_0 = \frac{0.45}{\sin\alpha} \left(\frac{Q^2}{Da} \right)^{\frac{1}{3}}$$

$$Q = \frac{Fa_0}{Z\sin\alpha}$$

Q : Axial load (N)

Da : Ball diameter of the support bearing (mm)

α : Initial contact angle of the support bearing (°)

Z : Number of balls

For details of a specific support bearing, contact its manufacturer.

[Axial Rigidity of the Nut Bracket and the Support Bearing Bracket]

Take this factor into consideration when designing your machine. Set the rigidity as high as possible.

Studying the Positioning Accuracy

Causes of Error in the Positioning Accuracy

The causes of error in the positioning accuracy include the lead angle accuracy, the axial clearance and the axial rigidity of the feed screw system. Other important factors include the thermal displacement from heat and the orientation change of the guide system during traveling.

Studying the Lead Angle Accuracy

It is necessary to select the correct accuracy grade of the Ball Screw that satisfies the required positioning accuracy from the Ball Screw accuracies (Table1 on **A15-12**). Table23 on **A15-50** shows examples of selecting the accuracy grades by the application.

Studying the Axial Clearance

The axial clearance is not a factor of positioning accuracy in single-directional feed. However, it will cause a backlash when the feed direction is inversed or the axial load is inversed. Select an axial clearance that meets the required backlash from Table10 and Table13 on **A15-19**.

Table23 Examples of Selecting Accuracy Grades by Application

Applications		Shaft	Accuracy grades							
			C0	C1	C2	C3	C5	C7	C8	C10
NC machine tools	Lathe	X		●	●	●	●			
		Z				●	●			
	Machining center	XY			●	●	●			
		Z			●	●	●			
	Drilling machine	XY				●	●			
		Z					●	●		
	Jig borer	XY	●	●						
		Z	●	●						
	Surface grinder	X				●	●			
		Y		●	●	●	●			
		Z		●	●	●	●			
	Cylindrical grinder	X	●	●	●					
		Z		●	●	●				
	Electric discharge machine	XY	●	●	●					
		Z		●	●	●	●			
	Electric discharge machine	XY	●	●	●					
		Z	●	●	●	●				
	Wire cutting machine	UV		●	●	●				
		XY				●	●	●		
	Laser beam machine	X				●	●	●		
Z					●	●	●			
Woodworking machine						●	●	●	●	
General-purpose machine; dedicated machine					●	●	●	●	●	
Industrial robot	Cartesian coordinate	Assembly				●	●	●	●	
		Other					●	●	●	
	Vertical articulated type	Assembly					●	●	●	
		Other						●	●	
Cylindrical coordinate					●	●	●			
Semiconductor manufacturing machine	Photolithography machine		●	●						
	Chemical treatment machine				●	●	●	●	●	
	Wire bonding machine			●	●					
	Prober		●	●	●	●				
	Printed circuit board drilling machine			●	●	●	●	●		
Electronic component inserter				●	●	●	●			
3D measuring instrument		●	●	●						
Image processing machine		●	●	●						
Injection molding machine							●	●	●	
Office equipment						●	●	●	●	

Studying the Axial Clearance of the Feed Screw System

Of the axial rigidities of the feed screw system, the axial rigidity of the screw shaft fluctuates according to the stroke position. When the axial rigidity is large, such change in the axial rigidity of the screw shaft will affect the positioning accuracy. Therefore, it is necessary to take into account the rigidity of the feed screw system (**A15-45** to **A15-48**).

Example: Positioning error due to the axial rigidity of the feed screw system during a vertical transfer

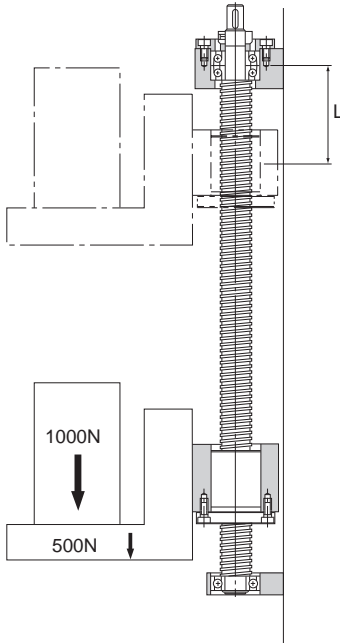

[Conditions]

Transferred weight: 1,000 N; table weight: 500 N

Ball Screw used: model BNF2512-2.5 (screw-shaft thread minor diameter $d_1 = 21.9$ mm)

Stroke length: 600 mm ($L=100$ mm to 700 mm)

Screw shaft mounting type: fixed-supported

[Consideration]

The difference in axial rigidity between $L = 100$ mm and $L = 700$ mm applied only to the axial rigidity of the screw shaft.

Therefore, positioning error due to the axial rigidity of the feed screw system equals to the difference in the axial displacement of the screw shaft between $L = 100$ mm and $L = 700$ mm.

[Axial Rigidity of the Screw Shaft (see A15-45 and A15-46)]

$$K_s = \frac{A \cdot E}{1000L} = \frac{376.5 \times 2.06 \times 10^5}{1000 \times L} = \frac{77.6 \times 10^3}{L}$$

$$A = \frac{\pi}{4} d_1^2 = \frac{\pi}{4} \times 21.9^2 = 376.5 \text{ mm}^2$$

$$E = 2.06 \times 10^5 \text{ N/mm}^2$$

(1) When $L = 100 \text{ mm}$

$$K_{s1} = \frac{77.6 \times 10^3}{100} = 776 \text{ N/}\mu\text{m}$$

(2) When $L = 700 \text{ mm}$

$$K_{s2} = \frac{77.6 \times 10^3}{700} = 111 \text{ N/}\mu\text{m}$$

[Axial Displacement due to Axial Rigidity of the Screw Shaft]

(1) When $L = 100 \text{ mm}$

$$\delta_1 = \frac{Fa}{K_{s1}} = \frac{1000+500}{776} = 1.9 \mu\text{m}$$

(2) When $L = 700 \text{ mm}$

$$\delta_2 = \frac{Fa}{K_{s2}} = \frac{1000+500}{111} = 13.5 \mu\text{m}$$

[Positioning Error due to Axial Rigidity of the Feed Screw System]

$$\begin{aligned} \text{Positioning accuracy} &= \delta_1 - \delta_2 = 1.9 - 13.5 \\ &= -11.6 \mu\text{m} \end{aligned}$$

Therefore, the positioning error due to the axial rigidity of the feed screw system is $11.6 \mu\text{m}$.

Studying the Thermal Displacement through Heat Generation

If the temperature of the screw shaft increases during operation, the screw shaft is elongated due to heat thereby to lower the positioning accuracy. The expansion and contraction of the screw shaft is calculated using the equation (42) below.

$$\Delta l = \rho \times \Delta t \times l \dots\dots\dots(42)$$

- Δl : Axial expansion/contraction of the screw shaft (mm)
 ρ : Thermal expansion coefficient ($12 \times 10^{-6}/^{\circ}\text{C}$)
 Δt : Temperature change in the screw shaft ($^{\circ}\text{C}$)
 l : Effective thread length (mm)

Thus, if the temperature of the screw shaft increases by 1°C , the screw shaft is elongated by $12 \mu\text{m}$ per meter. Therefore, as the Ball Screw travels faster, the more heat is generated. So, as the temperature increases, the positioning accuracy lowers. Accordingly, if high accuracy is required, it is necessary to take measures to cope with the temperature increase.

[Measures to Cope with the Temperature Rise]

● Minimize the Heat Generation

- Minimize the preloads on the Ball Screw and the support bearing.
- Increase the Ball Screw lead and reduce the rotational speed.
- Select a correct lubricant. (See Accessories for Lubrication on **A24-2**.)
- Cool the circumference of the screw shaft with a lubricant or air.

● Avoid Effect of Temperature Rise through Heat Generation

- Set a negative target value for the reference travel distance of the Ball Screw.
 Generally, set a negative target value for the reference travel distance assuming a temperature increase of 2°C to 5°C by heat.
 (-0.02mm to -0.06mm/m)
- Preload the shaft screw with tension. (See Fig.10 of the structure on **A15-29**.)

Studying the Orientation Change during Traveling

The lead angle accuracy of the Ball Screw equals the positioning accuracy of the shaft center of the Ball Screw. Normally, the point where the highest positioning accuracy is required changes according to the ball screw center and the vertical or horizontal direction. Therefore, the orientation change during traveling affects the positioning accuracy.

The largest factor of orientation change affecting the positioning accuracy is pitching if the change occurs in the ball screw center and the vertical direction, and yawing if the change occurs in the horizontal direction.

Accordingly, it is necessary to study the orientation change (accuracy in pitching, yawing, etc.) during the traveling on the basis of the distance from the ball screw center to the location where positioning accuracy is required.

Positioning error due to pitching and yawing is obtained using the equation (43) below.

$$A = \ell \times \sin\theta \quad \dots\dots(43)$$

A : Positioning accuracy due to pitching (or yawing) (mm)

ℓ : Vertical (or horizontal) distance from the ball screw center (mm) (see Fig.16)

θ : Pitching (or yawing) ($^{\circ}$)

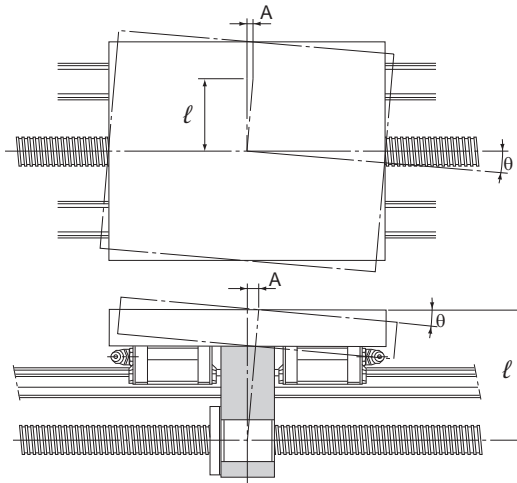

Fig.16

Studying the Rotational Torque

The rotational torque required to convert rotational motion of the Ball Screw into straight motion is obtained using the equation (44) below.

[During Uniform Motion]

$$(T_1 + T_2 + T_4) \cdot A \quad \dots\dots(44)$$

- T_1 : Rotation torque required during uniform motion (N-mm)
 T_1 : Friction torque due to an external load (N-mm)
 T_2 : Preload torque of the Ball Screw (N-mm)
 T_4 : Other torque (N-mm)
 (frictional torque of the support bearing and oil seal)
 A : Reduction ratio

[During Acceleration]

$$T_k = T_t + T_3 \quad \dots\dots(45)$$

- T_k : Rotation torque required during acceleration (N-mm)
 T_3 : Torque required for acceleration (N-mm)

[During Deceleration]

$$T_g = T_t - T_3 \quad \dots\dots(46)$$

- T_g : Rotational torque required for deceleration (N-mm)

Frictional Torque Due to an External Load

Of the turning forces required for the Ball Screw, the rotational torque needed for an external load (guide surface resistance or external force) is obtained using the equation (47) below.

$$T_1 = \frac{F_a \cdot Ph}{2\pi \cdot \eta} \quad \dots\dots(47)$$

- T_1 : Friction torque due to an external load (N-mm)
 F_a : Applied load (N)
 Ph : Ball Screw lead (mm)
 η : Ball Screw efficiency (0.9 to 0.95)

Torque Due to a Preload on the Ball Screw

For a preload on the Ball Screw, see "Preload Torque" on **A15-22**.

Torque Required for Acceleration

$$T_3 = J \times \omega' \times 10^3 \dots\dots(48)$$

T_3 : Torque required for acceleration (N-mm)

J : Inertial moment ($\text{kg}\cdot\text{m}^2$)

ω' : Angular acceleration (rad/s^2)

$$J = m \left(\frac{\text{Ph}}{2\pi} \right)^2 \cdot A^2 \cdot 10^{-6} + J_s \cdot A^2 + J_A \cdot A^2 + J_B$$

m : Transferred mass (kg)

Ph : Ball Screw lead (mm)

J_s : Inertial moment of the screw shaft ($\text{kg}\cdot\text{m}^2$)

(indicated in the specification tables of the respective model number)

A : Reduction ratio

J_A : Inertial moment of gears, etc. attached to the screw shaft side ($\text{kg}\cdot\text{m}^2$)

J_B : Inertial moment of gears, etc. attached to the motor side ($\text{kg}\cdot\text{m}^2$)

$$\omega' = \frac{2\pi \cdot \text{Nm}}{60t}$$

Nm : Motor revolutions per minute (min^{-1})

t : Acceleration time (s)

[Ref.] Inertial moment of a round object

$$J = \frac{m \cdot D^2}{8 \cdot 10^6}$$

J : Inertial moment ($\text{kg}\cdot\text{m}^2$)

m : Mass of a round object (kg)

D : Screw shaft outer diameter (mm)

Investigating the Terminal Strength of Ball Screw Shafts

When torque is conveyed through the screw shaft in a ball screw, the strength of the screw shaft must be taken into consideration since it experiences both torsion load and bending load.

[Screw shaft under torsion]

When torsion load is applied to the end of a ball screw shaft, use equation (49) to obtain the end diameter of the screw shaft.

$$T = \tau_a \cdot Z_P \quad \text{and} \quad Z_P = \frac{T}{\tau_a} \quad \dots\dots(49)$$

T : Maximum torsion moment (N-mm)

τ_a : Permissible torsion stress of the screw Shaft (49 N/mm²)

Z_P : Section modulus (mm³)

$$Z_P = \frac{\pi \cdot d^3}{16}$$

T: Torsion moment

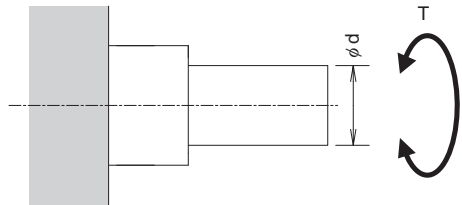

[Screw shaft under bending]

When bending load is applied to the end of a ball screw shaft, use equation (50) to obtain the end diameter of the screw shaft.

$$M = \sigma \cdot Z \quad \text{and} \quad Z = \frac{M}{\sigma} \quad \dots\dots(50)$$

M : Maximum bending moment (N-mm)

σ : Permissible bending stress of the screw shaft (98 N/mm²)

Z : Section Modulus (mm³)

$$Z = \frac{\pi \cdot d^3}{32}$$

M: Bending moment

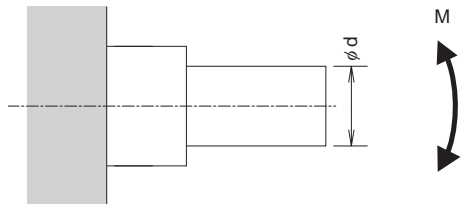

[If the shaft experiences both torsion and bending]

When torsion load and bending load are both applied simultaneously to the end of a ball screw shaft, calculate the diameter of the screw shaft separately for each, taking into consideration the corresponding bending moment (M_e) and the corresponding torsion moment (T_e). Then calculate the thickness of the screw shaft and use the largest of the values.

Equivalent bending moment

$$M_e = \frac{M + \sqrt{M^2 + T^2}}{2} = \frac{M}{2} \left\{ 1 + \sqrt{1 + \left(\frac{T}{M}\right)^2} \right\}$$

$$M_e = \sigma \cdot Z$$

Equivalent torsion moment

$$T_e = \sqrt{M^2 + T^2} = M \cdot \sqrt{1 + \left(\frac{T}{M}\right)^2}$$

$$T_e = \tau_a \cdot Z_P$$

Studying the Driving Motor

When selecting a driving motor required to rotate the Ball Screw, normally take into account the rotational speed, rotational torque and minimum feed amount.

When Using a Servomotor

[Rotational Speed]

The rotation speed required for the motor is obtained using the equation (51) based on the feed speed, Ball Screw lead and reduction ratio.

$$N_M = \frac{V \times 1000 \times 60}{Ph} \times \frac{1}{A} \dots\dots(51)$$

- N_M : Required rotation speed of the motor (min^{-1})
 V : Feeding speed (m/s)
 Ph : Ball Screw lead (mm)
 A : Reduction ratio

The rated rotational speed of the motor must be equal to or above the calculated value (N_M) above.

$$N_M \leq N_R$$

- N_R : The rated rotation speed of the motor (min^{-1})

[Required Resolution]

Resolutions required for the encoder and the driver are obtained using the equation (52) based on the minimum feed amount, Ball Screw lead and reduction ratio.

$$B = \frac{Ph \cdot A}{S} \dots\dots(52)$$

- B : Resolution required for the encoder and the driver (p/rev)
 Ph : Ball Screw lead (mm)
 A : Reduction ratio
 S : Minimum feed amount (mm)

[Motor Torque]

The torque required for the motor differs between uniform motion, acceleration and deceleration. To calculate the rotational torque, see “Studying the Rotational Torque” on **A15-55**.

a. Maximum torque

The maximum torque required for the motor must be equal to or below the maximum peak torque of the motor.

$$T_{\max} \leq T_{p\max}$$

T_{\max} : Maximum torque acting on the motor

$T_{p\max}$: Maximum peak torque of the motor

b. Effective torque value

The effective value of the torque required for the motor must be calculated. The effective value of the torque is obtained using the equation (53).

$$T_{\text{rms}} = \sqrt{\frac{T_1^2 \times t_1 + T_2^2 \times t_2 + T_3^2 \times t_3}{t}} \dots\dots\dots(53)$$

T_{rms} : Effective torque value (N-mm)

T_n : Fluctuating torque (N-mm)

t_n : Time during which the torque T_n is applied (s)

t : Cycle time (s)

$$(t=t_1+t_2+t_3)$$

The calculated effective value of the torque must be equal to or below the rated torque of the motor.

$$T_{\text{rms}} \leq T_R$$

T_R : Rated torque of the motor (N-mm)

[Inertial Moment]

The inertial moment required for the motor is obtained using the equation (54).

$$J_M = \frac{J}{C} \dots\dots\dots(54)$$

J_M : Inertial moment required for the motor ($\text{kg}\cdot\text{m}^2$)

C : Factor determined by the motor and the driver

(It is normally between 3 to 10. However, it varies depending on the motor and the driver. Check the specific value in the catalog by the motor manufacturer.)

The inertial moment of the motor must be equal to or above the calculated J_M value.

When Using a Stepping Motor (Pulse Motor)

[Minimal Feed Amount(per Step)]

The step angle required for the motor and the driver is obtained using the equation (55) based on the minimum feed amount, Ball Screw lead and reduction ratio.

$$E = \frac{360S}{Ph \cdot A} \dots\dots(55)$$

E : Step angle required for the motor and the driver (°)

S : Minimum feed amount (mm)
(per step)

Ph : Ball Screw lead (mm)

A : Reduction ratio

[Pulse Speed and Motor Torque]

a. Pulse speed

The pulse speed is obtained using the equation (56) based on the feed speed and the minimum feed amount.

$$f = \frac{V \times 1000}{S} \dots\dots(56)$$

f : Pulse speed (Hz)

V : Feeding speed (m/s)

S : Minimum feed amount (mm)

b. Torque required for the motor

The torque required for the motor differs between the uniform motion, the acceleration and the deceleration. To calculate the rotational torque, see “Studying the Rotational Torque” on **A15-55**.

Thus, the pulse speed required for the motor and the required torque can be calculated in the manner described above.

Although the torque varies depending on the motors, normally the calculated torque should be doubled to ensure safety. Check if the torque can be used in the motor’s speed-torque curve.

Ball Screw

Features of Each Model

Precision, Caged Ball Screw



Models SBN-V, SBK, SDA-V, HBN and SBKH

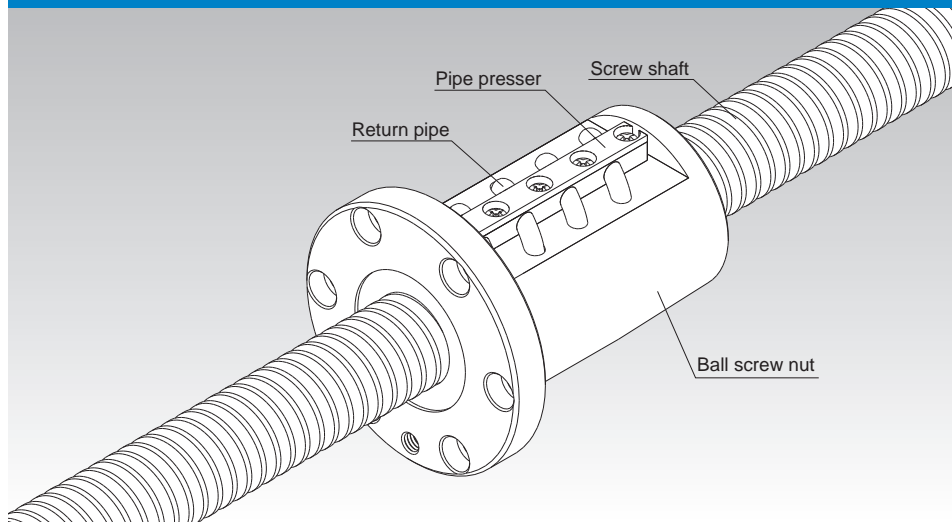

Fig.1 Structure of High-Speed Ball Screw with Ball Cage Model SBN-V

Point of Selection **A15-8**

Options **A15-336**

Model No. **A15-353**

Precautions on Use **A15-358**

Accessories for Lubrication **A24-1**

Mounting Procedure and Maintenance **B15-104**

Lead Angle Accuracy **A15-11**

Accuracy of the Mounting Surface **A15-14**

Axial Clearance **A15-19**

Maximum Length of the Screw Shaft **A15-24**

DN Value **A15-33**

Support Unit **A15-300**

Recommended Shapes of Shaft Ends **A15-308**

Dimensions of Each Model with an Option Attached **A15-344**

Structure and Features

The use of a ball cage in the Ball Screw with the Ball Cage eliminates collision and friction between balls and increases the grease retention. This makes it possible to achieve a low noise, a low torque fluctuation and a long-term maintenance-free operation.

In addition, this Ball Screw is superbly capable of responding to the high speed because of an ideal ball recirculation structure, a strengthened circulation path and an adoption of the ball cage.

Ball Cage Effect

[Low Noise, Acceptable Running Sound]

The use of the ball cage eliminates the collision noise between the balls. Additionally, as balls are picked up in the tangential direction, the collision noise from the ball circulation has also been eliminated.

[Long-term Maintenance-free Operation]

The friction between the balls has been eliminated, and the grease retention has been improved through the provision of grease pockets. As a result, the long-term maintenance-free operation (i.e., lubrication is unnecessary over a long period) is achieved.

[Smooth Motion]

The use of a ball cage eliminates the friction between the balls and minimizes the torque fluctuation, thus allowing the smooth motion to be achieved.

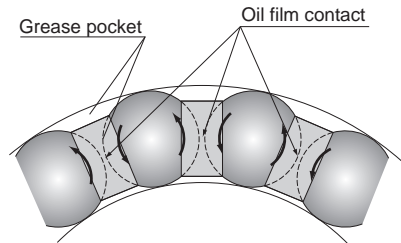
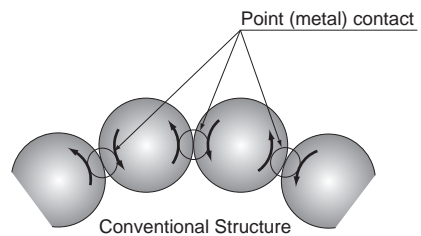

[Low Noise]

● Noise Level Data

Since the balls in the Ball Screw with the Ball Cage do not collide with each other, they do not produce a metallic sound and a low noise level is achieved.

■ Noise Measurement

[Conditions]

Item	Description
Sample	High load ball screw with ball cage HBN3210-5 Conventional type: model BNF3210-5
Stroke	600mm
Lubrication	Grease lubrication (lithium-based grease containing extreme pressure agent)

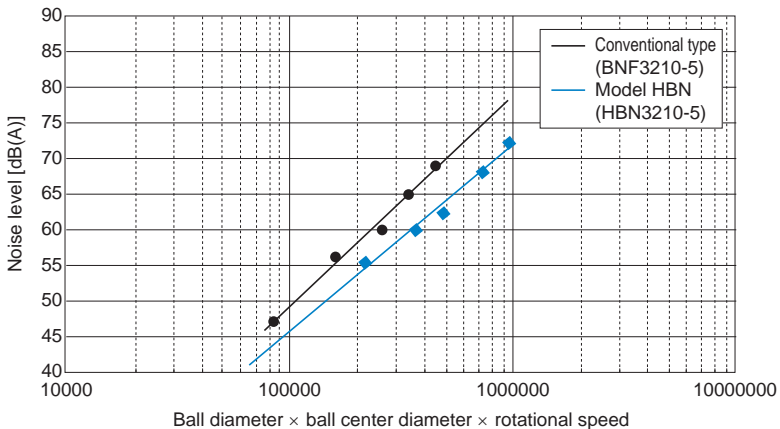
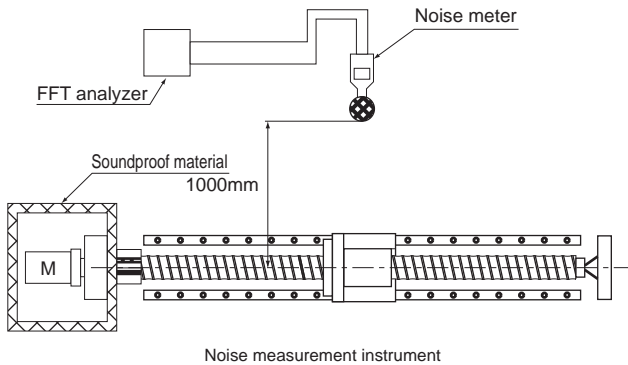

Fig.2 Ball Screw Noise Level

[Long-term Maintenance-free Operation]

● High speed, Load-bearing Capacity

Thanks to the ball circulating method supporting high speed and the caged ball technology, the Ball Screw with Ball Cage excels in high speed and load-bearing capacity.

■ High Speed Durability Test

[Test conditions]

Item	Description
Sample	High Speed Ball Screw with Ball Cage SDA3110V-5
Speed	5000(min^{-1})(DN value*: 160,000)
Stroke	500mm
Lubricant	THK AFJ Grease
Quantity	4 cm^3 (lubricated every 500km)
Applied load	1.27kN
Acceleration	0.5G

* DN value: Ball center-to-center diameter x revolutions per minute

[Test result]

Shows no deviation after running 6,000 km.

■ Load Bearing Test

[Test conditions]

Item	Description
Sample	High Speed Ball Screw with Ball Cage SBN5016V-5
Speed	1500(min^{-1})(DN value*: 79,000)
Stroke	400mm
Lubricant	THK AFG Grease
Quantity	57.7 cm^3 (Lubricated every 100 km)
Applied load	36.1kN(0.38Ca)
Acceleration	0.5G

[Test result]

Shows no deviation after running for the calculated service life

[Smooth Motion]

● Low Torque Fluctuation

The caged ball technology allows smoother motion than the conventional type to be achieved, thus to reduce torque fluctuation.

[Conditions]

Item	Description
Shaft diameter/lead	25/25mm
Shaft rotational speed	100 min^{-1}

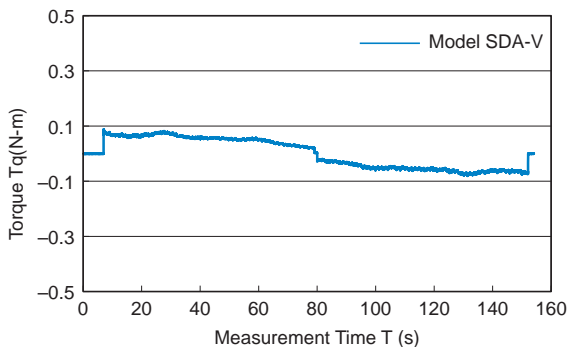

Fig.3 Torque Fluctuation Data

Types and Features

[Preload Type]

Model SBN-V

Specification Table⇒ **A15-72**

The circulation structure feature allows the balls to be picked up tangential to the direction of movement. The circulation components have been strengthened, increasing the DN value to 160,000 (small type: 130,000).

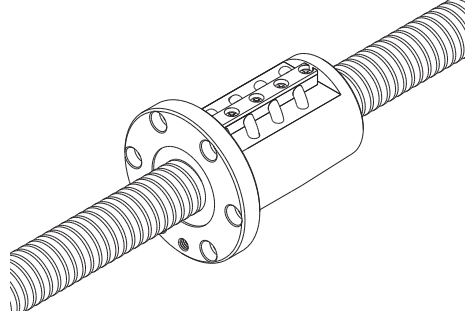

Model SBK

Specification Table⇒ **A15-76**

As a result of adopting the offset preloading method, which shifts two rows of grooves of the ball screw nut, a compact structure is achieved.

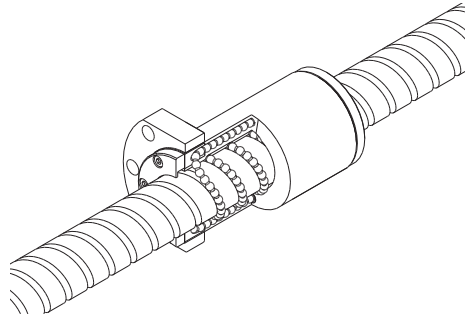

[Preload/No Preload Type]

Model SDA-V

Specification Table⇒ **A15-80**

A ball screw with newly developed circulation components that give it an ideal ball circulation structure. (Maximum DN value: 160,000)

The nut dimensions conform to DIN standards (DIN69051). Furthermore, the use of the newly developed thin film seal reduces the length of the nut, achieving a more compact design for the device.

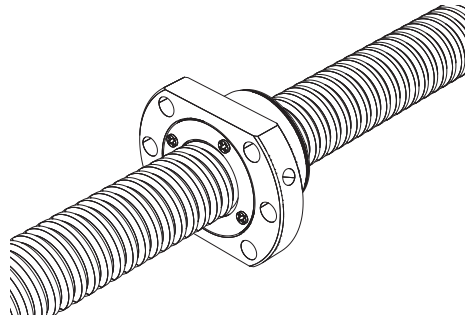

[No Preload Type]

Model HBN

With the optimal design for high loads, this Ball Screw model achieves a rated load more than twice the conventional type.

Specification Table⇒ **A15-86**

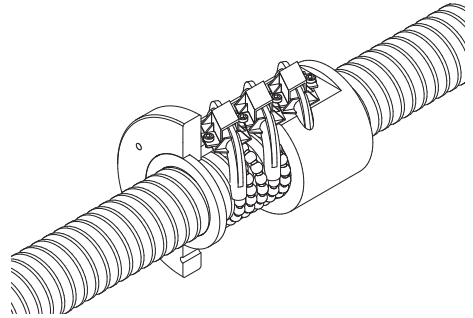

Model SBKH

Model SBKH is a ball screw that achieves a high load carrying capacity and is capable of high-speed operation (92 m/min at a maximum).

Specification Table⇒ **A15-88**

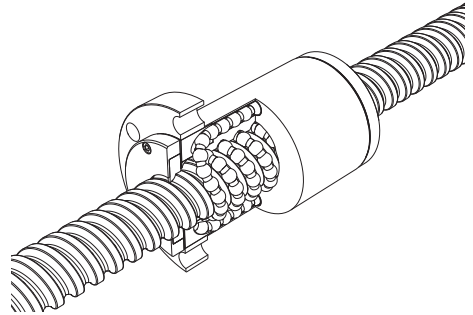

Examples of Assembling Models HBN and SBKH

If using model HBN or SBKH under a large load, arrange the nut flange and the fixed-side support unit in relation to the loading direction as indicated in the figure below while taking into account the load balance of the balls. In addition, while HBN or SBKH is operating, be sure not to apply a tensile load to the bolts. If you intend to use HBN or SBKH in configurations other than below, contact THK.

[Examples of Recommended Assembly of Models HBN and SBKH]

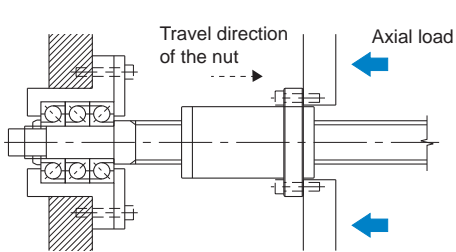

Good example (with the nut moving)

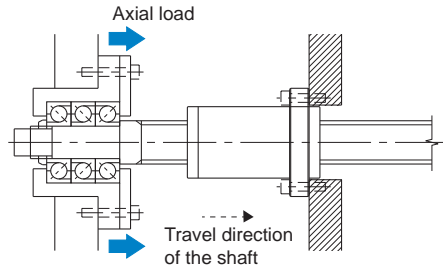

Good example (with the shaft moving)

[Examples of Un-recommended Assembly of Models HBN and SBKH]

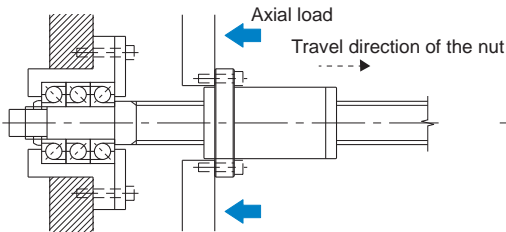

Bad example (with the nut moving)

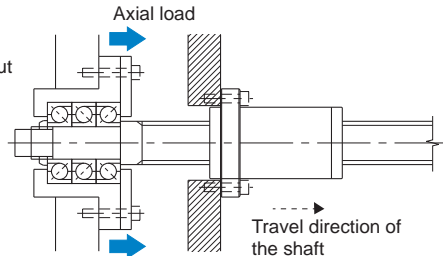

Bad example (with the shaft moving)

SBN-V Small With Preload

DN value	130000
----------	--------

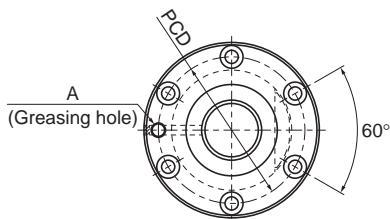

Model No.	Screw shaft outer diameter d	Lead Ph	Ball center-to-center diameter dp	Thread minor diameter dc	No. of loaded circuits Rows × turns	Basic load rating		Rigidity K N/μm
						Ca kN	C _{0a} kN	
SBN 1604V-5	16	4	16.5	13.8	1×2.5	5.3	8	281
SBN 1605V-5	16	5	16.75	13.2	1×2.5	9.2	12.9	309
SBN 2004V-5	20	4	20.5	17.8	1×2.5	5.9	10.1	335
SBN 2005V-5	20	5	20.75	17.2	1×2.5	10.3	16.2	370
SBN 2010V-5	20	10	20.75	17.2	1×2.5	10.2	16.4	362
SBN 2504V-5	25	4	25.5	22.8	1×2.5	6.4	12.7	400
SBN 2505V-5	25	5	25.75	22.2	1×2.5	11.3	20.3	442
SBN 2506V-5	25	6	26	21.4	1×2.5	15.4	25.4	457
SBN 2805V-5	28	5	28.75	25.2	1×2.5	11.8	22.8	483
SBN 3205V-5	32	5	32.75	29.2	1×2.5	12.6	26.1	536
SBN 3206V-5	32	6	33	28.4	1×2.5	17.2	32.7	555

Model number coding

SBN1604V-5 QZ RR G0 +1200L C5

Model No.

Contamination protection accessory symbol (*1)

Accuracy symbol (*2)

Overall screw shaft length (in mm)

With QZ lubricator
(No code without QZ lubricator)

Symbol for Clearance in the axial direction
(G0 for all SBN-V variations)

(*1) See [A15-336](#). (*2) See [A15-12](#).

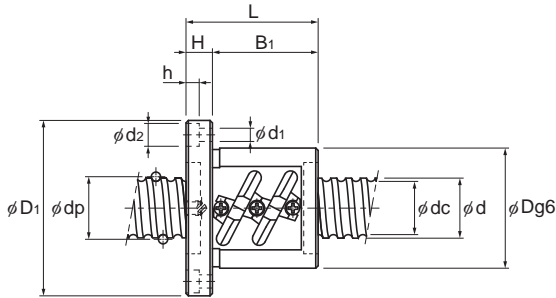

Unit: mm

	Nut dimensions							Greasing hole A	Screw shaft inertial moment/mm kg-cm ² /mm	Nut mass kg	Shaft mass kg/m
	Outer diameter	Flange diameter	Overall length	H	B ₁	PCD	d ₁ × d ₂ × h				
	Dg6	D ₁	L ₁								
	36	59	53	11	42	47	5.5 × 9.5 × 5.5	M6	5.05 × 10 ⁻⁴	0.42	1.42
	40	60	56	10	46	50	4.5 × 8 × 4.5		5.05 × 10 ⁻⁴	0.5	1.37
	40	63	49	11	38	51	5.5 × 9.5 × 5.5		1.23 × 10 ⁻³	0.43	2.22
	44	67	56	11	45	55	5.5 × 9.5 × 5.5		1.23 × 10 ⁻³	0.61	2.6
	46	74	90	15	75	59	5.5 × 9.5 × 5.5		1.23 × 10 ⁻³	1.06	2.33
	46	69	48	11	37	57	5.5 × 9.5 × 5.5		3.01 × 10 ⁻³	0.55	3.6
	50	73	55	11	44	61	5.5 × 9.5 × 5.5		3.01 × 10 ⁻³	0.72	3.52
	53	76	62	11	51	64	5.5 × 9.5 × 5.5		3.01 × 10 ⁻³	0.9	3.43
	55	85	59	12	47	69	6.6 × 11 × 6.5		4.74 × 10 ⁻³	0.98	4.45
	58	85	56	12	44	71	6.6 × 11 × 6.5		8.08 × 10 ⁻³	0.96	5.88
	62	89	63	12	51	75	6.6 × 11 × 6.5		8.08 × 10 ⁻³	1.22	5.89

Axial Clearance

Unit: mm

Clearance symbol	G0
Axial Clearance	0 or less

Note) The overall length of the nut will increase when equipping the QZ lubricating device. See **A15-344** for further details. It is not possible to chamfer both ends of the screw shaft. When designing your system this way, contact THK.

The rigidity values in the table represent spring constants, each obtained from the load and the elastic deformation when providing a preload equal to 10% of the basic axial dynamic load rating (Ca) and applying an axial load three times greater than the pre-load. These values do not include the rigidity of the components related to mounting the ball screw nut. Therefore, it is normally appropriate to regard roughly 80% of the value in the table as the actual value.

If the applied preload (Fa₀) is not 0.1 Ca, the rigidity value (K_s) is obtained from the following equation.

$$K_s = K \left(\frac{Fa_0}{0.1Ca} \right)^{\frac{1}{3}}$$

K: Rigidity value in the dimensional table.

SBN-V Medium With Preload

DN value	160000
----------	--------

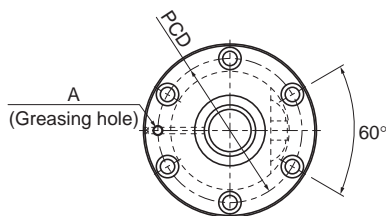

Model No.	Screw shaft outer diameter d	Lead Ph	Ball center-to-center diameter dp	Thread minor diameter dc	No. of loaded circuits Rows X turns	Basic load rating		Rigidity K N/μm
						Ca kN	Coa kN	
SBN 2508V-7	25	8	26.25	20.5	1×3.5	26.2	43	650
SBN 2510V-5	25	10	26.25	21.5	1×2.5	19.6	30.9	474
SBN 2810V-3	28	10	29.75	22.4	1×1.5	19.5	27.8	332
SBN 3210V-7	32	10	33.75	26.4	1×3.5	43	73.1	836.7
SBN 3212V-5	32	12	34	26.1	1×2.5	37.4	58.7	612.2
SBN 3216V-5	32	16	33.75	26.4	1×2.5	31.9	52.2	592
SBN 3610V-7	36	10	37.75	30.4	1×3.5	45.6	82.3	900
SBN 3612V-7	36	12	38	30.1	1×3.5	53.2	92.6	920
SBN 3616V-5	36	16	38	30.1	1×2.5	39.7	66.4	662
SBN 3620V-3	36	20	37.75	30.5	1×1.5	21.6	32.9	398
SBN 4010V-5	40	10	41.75	34.4	1×2.5	35.8	65.2	708
SBN 4012V-5	40	12	42	34.1	1×2.5	42	73.6	735.4
SBN 4016V-5	40	16	42	34.1	1×2.5	41.9	73.8	736.6
SBN 4020V-5	40	20	41.75	34.4	1×2.5	35.4	65.2	706
SBN 4510V-5	45	10	46.75	39.5	1×2.5	37.9	73.8	780
SBN 4512V-5	45	12	47	39.2	1×2.5	44.4	82.9	809.1
SBN 4516V-5	45	16	47	39.2	1×2.5	44.3	83.1	810.1
SBN 4520V-5	45	20	47	39.2	1×2.5	43.9	82.5	788
SBN 5010V-5	50	10	51.75	44.4	1×2.5	39.4	81	838
SBN 5012V-5	50	12	52.25	43.3	1×2.5	53.6	101.9	936
SBN 5016V-5	50	16	52.7	42.9	1×2.5	89	167.7	1228
SBN 5020V-5	50	20	52.7	42.9	1×2.5	88.7	167.7	1228

Model number coding

SBN4012V-5 QZ RR G0 +1200L C5

Model No.

Contamination protection accessory symbol ^(*)

Accuracy symbol ^(*)

Overall screw shaft length (in mm)

With QZ lubricator
(No code without QZ lubricator)

Symbol for Clearance in the axial direction
(G0 for all SBN-V variations)

(*) See **A15-336**. (**) See **A15-12**.

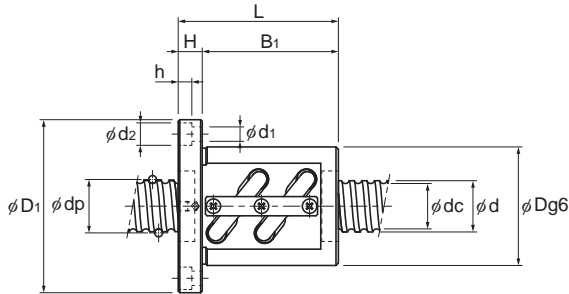

Unit: mm

	Nut dimensions							Greasing hole A	Screw shaft inertial moment/mm kg-cm ² /mm	Nut mass kg	Shaft mass kg/m
	Outer diameter Dg6	Flange diameter D ₁	Overall length L ₁	H	B ₁	PCD	d ₁ × d ₂ × h				
	58	85	98	15	83	71	6.6 × 11 × 6.5	M6	3.01 × 10 ⁻³	1.5	3.51
	58	85	100	18	82	71	6.6 × 11 × 6.5		3.01 × 10 ⁻³	1.31	3.5
	65	106	88	18	70	85	11 × 17.5 × 11		4.74 × 10 ⁻³	2.41	4.15
	74	108	120	15	105	90	9 × 14 × 8.5		8.08 × 10 ⁻³	3.1	5.53
	76	121	117	18	99	98	11 × 17.5 × 11		8.08 × 10 ⁻³	3.7	5.7
	74	108	139	18	121	90	9 × 14 × 8.5		8.08 × 10 ⁻³	3.81	5.82
	75	120	123	18	105	98	11 × 17.5 × 11		1.29 × 10 ⁻²	3.82	7.1
	78	123	140	18	122	100	11 × 17.5 × 11		1.29 × 10 ⁻²	4.34	7.99
	78	123	140	18	122	100	11 × 17.5 × 11		1.29 × 10 ⁻²	4.31	7.99
	75	114	122	18	104	93	11 × 17.5 × 11		1.29 × 10 ⁻²	3.4	7.54
	82	124	103	18	85	102	11 × 17.5 × 11		1.97 × 10 ⁻²	3.61	8.87
	84	126	119	18	101	104	11 × 17.5 × 11		1.97 × 10 ⁻²	4.2	8.83
	84	126	144	18	126	104	11 × 17.5 × 11		1.97 × 10 ⁻²	4.9	9.09
	82	126	162	18	144	104	11 × 17.5 × 11		1.97 × 10 ⁻²	5.17	9.37
	88	132	111	18	93	110	11 × 17.5 × 11	R1/8 (PT1/8)	3.16 × 10 ⁻²	4.29	11.36
	90	130	119	18	101	110	11 × 17.5 × 11		3.16 × 10 ⁻²	4.6	11.32
	90	130	140	18	122	110	11 × 17.5 × 11		3.16 × 10 ⁻²	5.3	11.61
	90	130	162	18	144	110	11 × 17.5 × 11		3.16 × 10 ⁻²	5.96	11.1
	93	135	103	18	85	113	11 × 17.5 × 11		4.82 × 10 ⁻²	4.28	14.16
	100	146	123	22	101	122	14 × 20 × 13		4.82 × 10 ⁻²	6.12	13.82
	105	152	164	25	139	128	14 × 20 × 13		4.82 × 10 ⁻²	8.82	13.71
	105	152	201	28	173	128	14 × 20 × 13		4.82 × 10 ⁻²	10.63	14.05

Axial Clearance

Unit: mm

Clearance symbol	G0
Axial Clearance	0 or less

Note) The overall length of the nut will increase when equipping the QZ lubricating device. See **A15-344** for further details.
It is not possible to chamfer both ends of the screw shaft. When designing your system this way, contact THK.

The rigidity values in the table represent spring constants, each obtained from the load and the elastic deformation when providing a preload equal to 10% of the basic axial dynamic load rating (Ca) and applying an axial load three times greater than the pre-load.

These values do not include the rigidity of the components related to mounting the ball screw nut.

Therefore, it is normally appropriate to regard roughly 80% of the value in the table as the actual value.

If the applied preload (Fa₀) is not 0.1 Ca, the rigidity value (K_v) is obtained from the following equation.

$$K_v = K \left(\frac{F_{a0}}{0.1Ca} \right)^{\frac{1}{3}}$$

K: Rigidity value in the dimensional table.

SBK With Preload

DN value	SBK3636,4040,5050	160000
	All other Model SBK units	210000

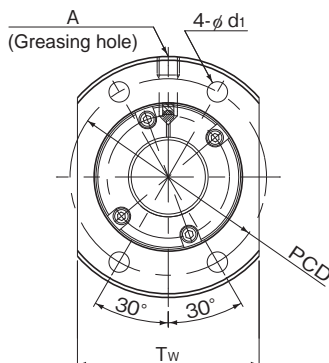

Model No.	Screw shaft outer diameter d	Lead Ph	Ball center-to-center diameter dp	Thread minor diameter dc	No. of loaded circuits Rows X turns	Basic load rating		Rigidity K N/μm
						Ca kN	C _a kN	
SBK 1520-3.6	15	20	15.75	12.2	1×1.8	5.8	7.8	178
SBK 1616-3.6	16	16	16.65	13.5	1×1.8	4.6	6.4	182
SBK 2010-5.6	20	10	20.75	17.2	1×2.8	10.7	17.3	353
SBK 2020-3.6	20	20	20.75	17.2	1×1.8	7	10.5	229
SBK 2030-3.6	20	30	20.75	17.2	1×1.8	6.9	11.2	236
SBK 2520-3.6	25	20	26	21.5	1×1.8	11	16.9	292
SBK 2525-3.6	25	25	26	21.5	1×1.8	10.8	16.9	290
SBK 3220-5.6	32	20	33.25	27.9	1×2.8	23.6	41.1	565
SBK 3232-5.6	32	32	33.25	27.9	1×2.8	23.1	41.8	567

Axial Clearance

Unit: mm

Clearance symbol	G0
Axial Clearance	0 or less

Model number coding

SBK2525-3.6 QZ G0 +1200L C5

Model Number

Overall screw shaft
length (in mm)

Accuracy symbol (r1)

Symbol for clearance in the axial direction
(G0 for all SBK variations)With QZ Lubricator
(no symbol if the model is without a QZ Lubricator)(*1) See **A15-12**.

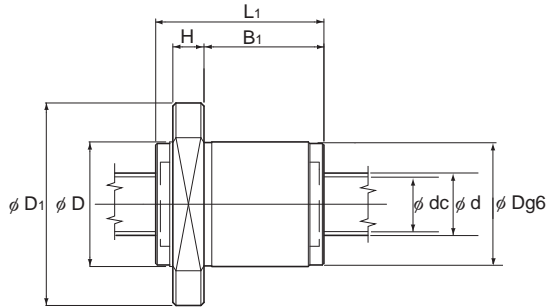

Unit: mm

	Nut dimensions									Screw shaft inertial moment/mm kg-cm ² /mm	Nut mass kg	Shaft mass kg/m	Maximum permissible rotation speed min ⁻¹
	Outer diameter D	Flange diameter D ₁	Overall length L ₁	H	B ₁	PCD	d ₁	T _w	Greasing hole A				
	38	62	54	10	38.5	49	5.5	39	M6	3.9×10^{-4}	0.41	1.27	5000
	33	54	45	10	29.5	43	4.5	38	M6	5.05×10^{-4}	0.25	1.46	
	40	65	45	10	29.5	53	5.5	49	M6	1.23×10^{-3}	0.37	2.18	
	40	65	54	10	38.5	53	5.5	49	M6	1.23×10^{-3}	0.43	2.32	
	40	65	71	10	55.5	53	5.5	49	M6	1.23×10^{-3}	0.55	2.36	
	47	74	57	12	38	60	6.6	56	M6	3.01×10^{-3}	0.59	3.58	
	47	74	68	12	49	60	6.6	56	M6	3.01×10^{-3}	0.69	3.63	
	58	92	82	15	58	74	9	68	M6	8.08×10^{-3}	1.23	5.82	3900
	58	92	118	15	94	74	9	68	M6	8.08×10^{-3}	1.70	5.99	

Note) The rigidity values in the table represent spring constants, each obtained from the load and the elastic deformation when providing a preload equal to 10% of the basic axial dynamic load rating (Ca) and applying an axial load three times greater than the pre-load.

These values do not include the rigidity of the components related to mounting the ball screw nut. Therefore, it is normally appropriate to regard roughly 80% of the value in the table as the actual value.

If the applied preload (Fa₀) is not 0.1 Ca, the rigidity value (K_N) is obtained from the following equation.

$$K_N = K \left(\frac{Fa_0}{0.1Ca} \right)^{\frac{1}{3}}$$

K: Rigidity value in the dimensional table.

SBK With Preload

DN value	SBK3636,4040,5050	160000
	All other Model SBK units	210000

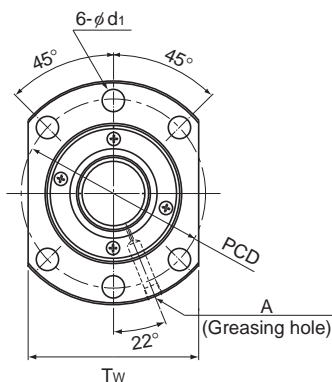

Model No.	Screw shaft outer diameter d	Lead Ph	Ball center-to-center diameter dp	Thread minor diameter dc	No. of loaded circuits Rows X turns	Basic load rating		Rigidity K N/μm
						Ca kN	C _a kN	
SBK 3620-7.6	36	20	37.75	30.4	1×3.8	48.5	85	870
SBK 3636-5.6	36	36	37.75	31.4	1×2.8	36.6	64.7	460
SBK 4020-7.6	40	20	42	34.1	1×3.8	59.7	112.7	970
SBK 4030-7.6	40	30	42	34.1	1×3.8	59.2	107.5	970
SBK 4040-5.6	40	40	42	34.9	1×2.8	44.8	80.3	520
SBK 5020-7.6	50	20	52	44.1	1×3.8	66.8	141.9	1170
SBK 5030-7.6	50	30	52	44.1	1×3.8	66.5	135	1170
SBK 5036-7.6	50	36	52	44.1	1×3.8	65.9	135	1170
SBK 5050-5.6	50	50	52	44.9	1×2.8	50.3	102.4	630
SBK 5520-7.6	55	20	57	49.1	1×3.8	69.8	156.4	1250
SBK 5530-7.6	55	30	57	49.1	1×3.8	69.2	147	1250
SBK 5536-7.6	55	36	57	49.1	1×3.8	69.1	148.7	1260

Note) With model SBK, the raising of both ends of the thread groove is not available. When designing your system this way, contact THK.

Axial Clearance

Unit: mm

Clearance symbol	G0
Axial Clearance	0 or less

Model number coding

SBK3620-7.6 RR G0 +1500L C5

Model number Seal symbol (*1) Overall screw shaft length (in mm) Accuracy symbol (*2)

Symbol for clearance in the axial direction (G0 for all SBK variations)

(*1) See **A15-336**. (*2) See **A15-12**.

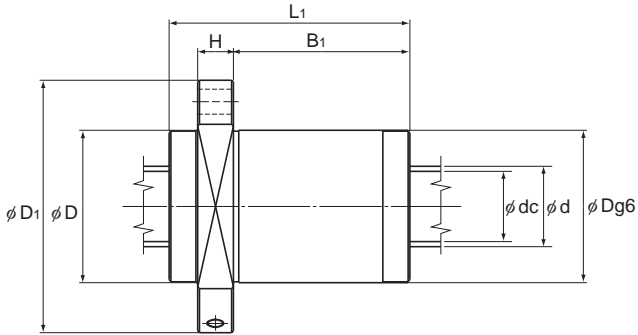

Unit: mm

	Nut dimensions									Screw shaft inertial moment/mm kg-cm ² /mm	Nut mass kg	Shaft mass kg/m
	Outer diameter D	Flange diameter D ₁	Overall length L ₁	H	B ₁	PCD	d _i	T _w	Greasing hole A			
73	114	110	18	81	93	11	86	PT 1/8	1.29×10 ⁻²	3.4	5.0	
73	114	134	18	105	93	11	86	PT 1/8	1.29×10 ⁻²	3.37	7.43	
80	136	110	20	79	112	14	103	PT 1/8	1.97×10 ⁻²	4.5	5.7	
80	136	148	20	117	112	14	103	PT 1/8	1.97×10 ⁻²	5.6	7.0	
80	136	146	20	115	112	14	103	PT 1/8	1.97×10 ⁻²	4.74	9.16	
90	146	110	22	77	122	14	110	PT 1/8	4.82×10 ⁻²	5.3	10.2	
90	146	149	22	116	122	14	110	PT 1/8	4.82×10 ⁻²	6.6	11.9	
90	146	172	22	139	122	14	110	PT 1/8	4.82×10 ⁻²	7.4	12.5	
90	146	175	22	142	122	14	110	PT 1/8	4.82×10 ⁻²	6.46	14.72	
96	152	110	22	77	128	14	114	PT 1/8	7.05×10 ⁻²	5.7	13.0	
96	152	149	22	116	128	14	114	PT 1/8	7.05×10 ⁻²	7.2	14.8	
96	152	172	22	139	128	14	114	PT 1/8	7.05×10 ⁻²	8.1	15.5	

Note) The rigidity values in the table represent spring constants, each obtained from the load and the elastic deformation when providing a preload equal to 10% of the basic axial dynamic load rating (Ca) and applying an axial load three times greater than the pre-load.

These values do not include the rigidity of the components related to mounting the ball screw nut. Therefore, it is normally appropriate to regard roughly 80% of the value in the table as the actual value.

If the applied preload (Fa₀) is not 0.1 Ca, the rigidity value (K_N) is obtained from the following equation.

$$K_N = K \left(\frac{Fa_0}{0.1Ca} \right)^{\frac{1}{3}}$$

K: Rigidity value in the dimensional table.

SDA-V

With Preload/No Preload

DN value	160000
----------	--------

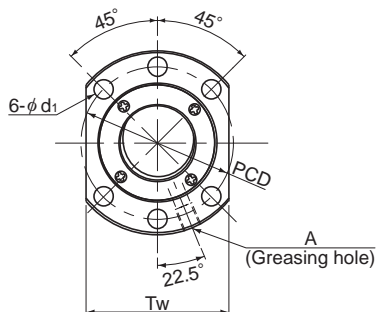

Model No.	Screw shaft outer diameter d	Lead Ph	Ball center-to-center diameter dp	Screw shaft Thread minor diameter dc	No. of loaded circuits Rows X turns	Basic load rating				Rigidity	
						SDA-V (With Retainer)		SDA-VZ (Full-Complement Bearings)		SDA-V (With Retainer)	SDA-VZ (Full-Complement Bearings)
						Ca kN	C _{0a} kN	Ca kN	C _{0a} kN	K N/μm	K N/μm
SDA 1505V-3	15	5	15.5	13.1	1×3	5.9	7.9	5.6	8.8	140	153
SDA 1510V-3	15	10	15.5	13.1	1×3	5.8	7.6	5.5	8.4	141	154
SDA 1520V-4	15	20	15.5	13.1	2×2	6.8	10.1	6.5	11.2	181	198
SDA 1530V-4	15	30	15.5	13.1	2×2	6.5	8.8	6.2	9.7	188	205
SDA 1605V-3	16	5	16.5	14.1	1×3	6	8.4	5.8	9.4	147	162
SDA 1610V-3	16	10	16.5	14.1	1×3	6	8.1	5.7	9	148	163
SDA 1616V-3	16	16	16.5	14.1	1×3	5.9	8.4	5.6	9.2	151	165
SDA 2005V-3	20	5	20.75	17.1	1×3	11.7	17.7	11.1	18.9	200	213
SDA 2010V-3	20	10	20.75	17.1	1×3	11.6	17.7	11	19	200	213
SDA 2020V-3	20	20	20.75	17.1	1×3	11.4	17.2	10.8	18.5	203	217
SDA 2030V-2	20	30	20.75	17.1	1×2	7.4	11.5	7	12.3	135	143
SDA 2040V-2	20	40	20.75	17.1	1×2	7.1	9.7	6.8	10.4	137	147
SDA 2505V-3	25	5	25.75	22.1	1×3	12.9	22	12.3	23.7	237	254
SDA 2510V-3	25	10	25.75	22.1	1×3	12.8	22	12.2	23.8	237	254
SDA 2520V-3	25	20	25.75	22.1	1×3	12.7	21.3	12.1	22.9	241	257
SDA 2525V-3	25	25	25.75	22.1	1×3	12.5	21.6	11.9	23.3	243	259
SDA 2530V-2	25	30	25.75	22.1	1×2	8.3	13.9	7.9	14.9	158	168
SDA 2550V-2	25	50	25.75	22.1	1×2	7.8	12.1	7.5	13.1	163	176

Model number coding

SDA2005V Z -3 TT G0 +830L C5

Model No. Full-complement bearings type code (No code for retainer type)	Number of turns Contamination protection accessory symbol (*1)	Overall screw shaft length (in mm) Axial direction clearance code (*2) (Preloaded products: GO Clearance, Non-preloaded products: GT Clearance)	Accuracy symbol (*3)
--	--	---	----------------------

(*1) See **A15-336**. (*2) See **A15-19**. (*3) See **A15-12**.

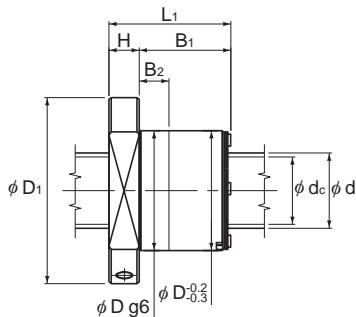

Unit: mm

	Nut dimensions										Screw shaft inertial moment/mm ²	Nut mass	Shaft mass	Permissible Rotational Speed				
	Outer diameter	Flange diameter	Overall length	H	B ₁	B ₂	PCD	d ₁	T _w	Greasing hole				kg-cm ² /mm	kg	kg/m	SDA-V (With Retainer)	SDA-VZ (Full-Complement Bearings)
																	min ⁻¹	min ⁻¹
D	D ₁	L ₁	H	B ₁	B ₂	PCD	d ₁	T _w	A	kg-cm ² /mm	kg	kg/m	min ⁻¹	min ⁻¹				
28	48	25	10	15	12.5	38	5.5	40	M6	3.9×10 ⁻⁴	0.13	1.27	5000	5000				
28	48	38	10	28	10	38	5.5	40	M6	3.9×10 ⁻⁴	0.17	1.33	5000	5000				
28	48	46	10	36	10	38	5.5	40	M6	3.9×10 ⁻⁴	0.19	1.33	5000	5000				
28	48	65	10	55	10	38	5.5	40	M6	3.9×10 ⁻⁴	0.25	1.34	5000	5000				
28	48	25	10	15	12.5	38	5.5	40	M6	5.05×10 ⁻⁴	0.13	1.46	5000	5000				
28	48	39	10	29	10	38	5.5	40	M6	5.05×10 ⁻⁴	0.16	1.52	5000	5000				
28	48	56	10	46	10	38	5.5	40	M6	5.05×10 ⁻⁴	0.21	1.54	5000	5000				
36	58	27	10	17	13.5	47	6.6	44	M6	1.23×10 ⁻³	0.18	2.21	5000	4819				
36	58	40	10	30	10	47	6.6	44	M6	1.23×10 ⁻³	0.25	2.34	5000	4819				
36	58	67	10	57	12	47	6.6	44	M6	1.23×10 ⁻³	0.39	2.4	5000	4819				
36	58	66	10	56	12	47	6.6	44	M6	1.23×10 ⁻³	0.38	2.42	5000	4819				
36	58	84	10	74	12	47	6.6	44	M6	1.23×10 ⁻³	0.47	2.43	5000	4819				
40	62	27	10	17	13.5	51	6.6	48	M6	3.01×10 ⁻³	0.2	3.53	5000	3883				
40	62	40	10	30	10	51	6.6	48	M6	3.01×10 ⁻³	0.28	3.7	5000	3883				
40	62	67	10	57	16	51	6.6	48	M6	3.01×10 ⁻³	0.42	3.78	5000	3883				
40	62	82	10	72	16	51	6.6	48	M6	3.01×10 ⁻³	0.5	3.79	5000	3883				
40	62	66	10	56	16	51	6.6	48	M6	3.01×10 ⁻³	0.41	3.8	5000	3883				
40	62	102	10	92	16	51	6.6	48	M6	3.01×10 ⁻³	0.61	3.83	5000	3883				

Axial Clearance

Unit: mm

Clearance symbol	G0	GT
Axial Clearance	0 or less	0 to 0.005

Note) The overall length of the nut will increase when equipping the QZ lubricating device. See **A15-344** for further details. It is not possible to chamfer both ends of the screw shaft. When designing your system this way, contact THK.

The rigidity values (K) in the table represent spring constants, each obtained from the load and the elastic deformation under an axial load equal to 30% of the basic axial dynamic load rating (Ca).

These values do not include the rigidity of the components related to mounting the ball screw nut. Therefore, it is normally appropriate to regard roughly 80% of the rigidity value (K) in the table as the actual value.

If the axial load (Fa) is not 0.3 Ca, the rigidity value (K_a) is obtained from the following equation.

$$K_a = K \left(\frac{Fa}{0.3Ca} \right)^3$$

K: Rigidity value in the dimensional table.

SDA-V With Preload/No Preload

DN value	160000
----------	--------

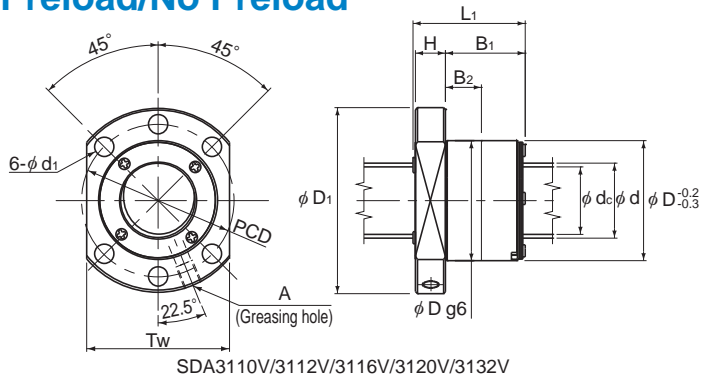

Model No.	Screw shaft outer diameter	Lead	Ball center-to-center diameter	Screw shaft Thread minor diameter	No. of loaded circuits	Basic load rating				Rigidity	
						SDA-V (With Retainer)		SDA-VZ (Full-Complement Bearings)		SDA-V (With Retainer)	SDA-VZ (Full-Complement Bearings)
						Ca	C _{0a}	Ca	C _{0a}	K	K
d	Ph	dp	dc	Rows X turns	kN	kN	kN	kN	N/ μ m	N/ μ m	
SDA 3110V-5	31	10	32	25.4	1×5	57.1	94.7	54.4	99.7	529	554
SDA 3112V-5	31	12	32	25.4	1×5	57	94.7	54.3	99.9	529	555
SDA 3116V-5	31	16	32	25.4	1×5	56.8	96	54.1	100.5	534	556
SDA 3120V-5	31	20	32	25.4	1×5	56.6	90.3	53.9	95.1	533	558
SDA 3132V-2	31	32	32	25.4	1×2	23.2	33.8	22.1	35.4	206	214
SDA 3610V-5	36	10	37	30.4	1×5	61.7	110.6	58.8	116.4	598	626
SDA 3612V-5	36	12	37	30.4	1×5	61.7	110.6	58.7	116.6	598	627
SDA 3616V-5	36	16	37	30.4	1×5	61.5	111.9	58.6	117.1	603	628
SDA 3620V-5	36	20	37	30.4	1×5	61.3	105.2	58.4	110.6	602	629
SDA 3636V-2	36	36	37	30.4	1×2	25.1	39.3	23.9	41.3	232	242
SDA 3810V-5	38	10	39	32.4	1×5	63.4	117.7	60.4	123.1	629	654
SDA 3812V-5	38	12	39	32.4	1×5	63.4	117.7	60.3	123.3	628	655
SDA 3816V-5	38	16	39	32.4	1×5	63.2	117.7	60.2	123.7	627	656
SDA 3820V-5	38	20	39	32.4	1×5	63	111.9	60	116.9	632	657
SDA 3825V-4	38	25	39	32.4	1×4	51.1	87.8	48.6	92.7	500	525
SDA 3830V-3	38	30	39	32.4	1×3	38.7	64.9	36.9	68.2	373	390
SDA 3840V-2	38	40	39	32.4	1×2	25.7	42	24.4	43.9	244	253

Model number coding

SDA3810V Z -5 TT G0 +830L C5

Model No. | Number of turns | Overall screw shaft length (in mm) | Accuracy symbol (*3)
 Full-complement bearings type code (No code for retainer type) | Contamination protection accessory symbol (*1) | Axial direction clearance code (*2) (Preloaded products: GO Clearance, Non-preloaded products: GT Clearance)

(*1) See **A15-336**. (*2) See **A15-19**. (*3) See **A15-12**.

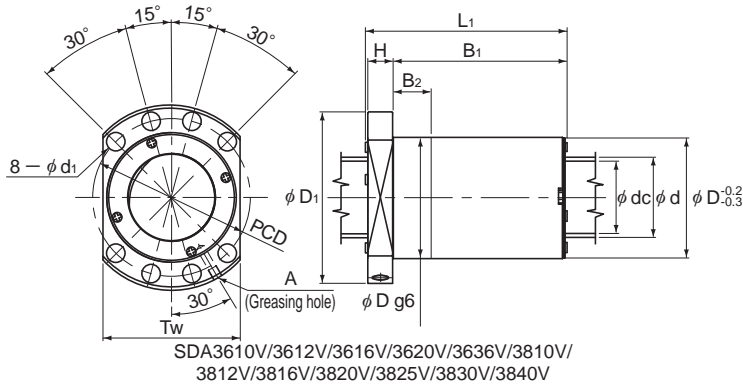

Unit: mm

Nut dimensions											Screw shaft inertial moment/mm ²	Nut mass	Shaft mass	Permissible Rotational Speed	
Outer diameter	Flange diameter	Overall length	H	B ₁	B ₂	PCD	d ₁	T _w	Greasing hole	A				kg-cm ² /mm	kg
D	D ₁	L ₁	H	B ₁	B ₂	PCD	d ₁	T _w	A					min ⁻¹	min ⁻¹
56	86	65	14	50	20	71	9	65	M6		7.07 × 10 ⁻³	0.96	5.02	5000	4063
56	86	74	14	59	20	71	9	65	M6		7.07 × 10 ⁻³	1.08	5.17	5000	4063
56	86	93	14	78	20	71	9	65	M6		7.07 × 10 ⁻³	1.31	5.36	5000	4063
56	86	112	14	97	20	71	9	65	M6		7.07 × 10 ⁻³	1.54	5.47	5000	4063
56	86	73	14	58	20	71	9	65	M6		7.07 × 10 ⁻³	1.04	5.63	5000	4063
61	91	65	14	50	20	76	9	68	M8 × 1		1.29 × 10 ⁻²	1.06	6.93	4324	3514
61	91	74	14	59	20	76	9	68	M8 × 1		1.29 × 10 ⁻²	1.19	7.11	4324	3514
61	91	93	14	78	20	76	9	68	M8 × 1		1.29 × 10 ⁻²	1.45	7.34	4324	3514
61	91	112	14	97	20	76	9	68	M8 × 1		1.29 × 10 ⁻²	1.7	7.47	4324	3514
61	91	81	14	66	20	76	9	68	M8 × 1		1.29 × 10 ⁻²	1.24	7.69	4324	3514
63	93	65	14	50	20	78	9	70	M8 × 1		1.6 × 10 ⁻²	1.1	7.79	4103	3333
63	93	74	14	59	20	78	9	70	M8 × 1		1.6 × 10 ⁻²	1.23	7.97	4103	3333
63	93	93	14	78	20	78	9	70	M8 × 1		1.6 × 10 ⁻²	1.5	8.21	4103	3333
63	93	112	14	97	20	78	9	70	M8 × 1		1.6 × 10 ⁻²	1.77	8.35	4103	3333
63	93	111	14	96	20	78	9	70	M8 × 1		1.6 × 10 ⁻²	1.73	8.45	4103	3333
63	93	100	14	85	20	78	9	70	M8 × 1		1.6 × 10 ⁻²	1.56	8.53	4103	3333
63	93	87	14	72	20	78	9	70	M8 × 1		1.6 × 10 ⁻²	1.38	8.62	4103	3333

Axial Clearance

Unit: mm

Clearance symbol	G0	GT
Axial Clearance	0 or less	0 to 0.005

Note) The overall length of the nut will increase when equipping the QZ lubricating device. See [A15-344](#) for further details. It is not possible to chamfer both ends of the screw shaft. When designing your system this way, contact THK.

The rigidity values (K) in the table represent spring constants, each obtained from the load and the elastic deformation under an axial load equal to 30% of the basic axial dynamic load rating (Ca). These values do not include the rigidity of the components related to mounting the ball screw nut. Therefore, it is normally appropriate to regard roughly 80% of the rigidity value (K) in the table as the actual value. If the axial load (Fa) is not 0.3 Ca, the rigidity value (K_v) is obtained from the following equation.

$$K_v = K \left(\frac{F_a}{0.3C_a} \right)^3$$

K: Rigidity value in the dimensional table.

SDA-V With Preload/No Preload

DN value	160000
----------	--------

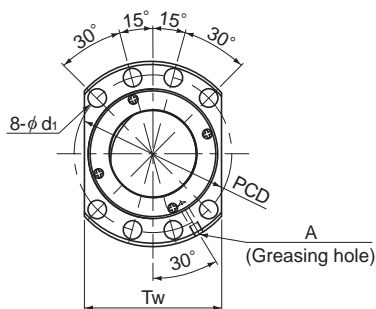

Model No.	Screw shaft outer diameter d	Lead Ph	Ball center-to-center diameter dp	Screw shaft Thread minor diameter dc	No. of loaded circuits Rows X turns	Basic load rating				Rigidity	
						SDA-V (With Retainer)		SDA-VZ (Full-Complement Bearings)		SDA-V (With Retainer)	SDA-VZ (Full-Complement Bearings)
						Ca kN	C _{0a} kN	Ca kN	C _{0a} kN	K N/μm	K N/μm
SDA 4510V-5	45	10	46	39.4	1×5	68.7	139.4	65.4	146.5	717	749
SDA 4512V-5	45	12	46	39.4	1×5	68.6	139.4	65.4	146.7	717	750
SDA 4516V-5	45	16	46	39.4	1×5	68.5	140.7	65.3	147	722	751
SDA 4520V-5	45	20	46	39.4	1×5	68.4	140.7	65.1	147.5	721	752
SDA 4525V-4	45	25	46	39.4	1×4	55.5	104	52.8	109.8	572	600
SDA 4530V-4	45	30	46	39.4	1×4	55.3	105.3	52.6	110.5	577	602
SDA 4540V-3	45	40	46	39.4	1×3	41.7	78.3	39.7	81.9	431	449
SDA 5010V-5	50	10	51	44.4	1×5	72	155.2	68.6	163.2	780	815
SDA 5012V-5	50	12	51	44.4	1×5	72	155.2	68.5	163.3	779	816
SDA 5016V-5	50	16	51	44.4	1×5	71.9	156.6	68.4	163.7	785	816
SDA 5020V-5	50	20	51	44.4	1×5	71.7	156.6	68.3	164.2	784	817
SDA 5025V-4	50	25	51	44.4	1×4	58.2	123.6	55.5	129.8	624	652
SDA 5030V-4	50	30	51	44.4	1×4	58	117.5	55.3	122.6	629	654
SDA 5040V-3	50	40	51	44.4	1×3	43.9	86.5	41.8	90.7	467	487
SDA 5050V-2	50	50	51	44.4	1×2	29.2	55.5	27.8	58	303	316

Model number coding

SDA4510V Z -5 TT GO +830L C5

Model No.	Number of turns	Overall screw shaft length (in mm)	Accuracy symbol ^(*)
Full-complement bearings type code (No code for retainer type)	Contamination protection accessory symbol ^(*)	Axial direction clearance code ^(*) (Preloaded products: GO Clearance, Non-preloaded products: GT Clearance)	

(*) See **A15-336**. ^(*) See **A15-19**. ^(*) See **A15-12**.

Precision, Caged Ball Screw

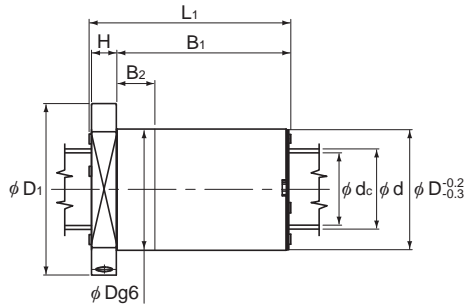

Unit: mm

	Nut dimensions										Screw shaft inertial moment/mm	Nut mass	Shaft mass	Permissible Rotational Speed				
	Outer diameter	Flange diameter	Overall length	H	B ₁	B ₂	PCD	d _i	T _w	A				kg-cm ² /mm	kg	kg/m	SDA-V (With Retainer)	SDA-VZ (Full-Completion Bearings)
																	min ⁻¹	min ⁻¹
D	D ₁	L ₁	H	B ₁	B ₂	PCD	d _i	T _w	A	kg-cm ² /mm	kg	kg/m	min ⁻¹	min ⁻¹				
70	105	65	16	48	20	88	11	80	M8×1	3.16×10 ⁻²	1.35	11.16	3478	2826				
70	105	74	16	57	20	88	11	80	M8×1	3.16×10 ⁻²	1.5	11.38	3478	2826				
70	105	93	16	76	20	88	11	80	M8×1	3.16×10 ⁻²	1.81	11.67	3478	2826				
70	105	112	16	95	20	88	11	80	M8×1	3.16×10 ⁻²	2.11	11.84	3478	2826				
70	105	110	16	93	20	88	11	80	M8×1	3.16×10 ⁻²	2.04	11.95	3478	2826				
70	105	130	16	113	20	88	11	80	M8×1	3.16×10 ⁻²	2.36	12.04	3478	2826				
70	105	129	16	112	20	88	11	80	M8×1	3.16×10 ⁻²	2.33	12.16	3478	2826				
75	110	65	16	48	20	93	11	85	M8×1	4.82×10 ⁻²	1.46	13.93	3137	2549				
75	110	74	16	57	20	93	11	85	M8×1	4.82×10 ⁻²	1.63	14.19	3137	2549				
75	110	93	16	76	20	93	11	85	M8×1	4.82×10 ⁻²	1.96	14.5	3137	2549				
75	110	112	16	95	20	93	11	85	M8×1	4.82×10 ⁻²	2.29	14.69	3137	2549				
75	110	110	16	93	20	93	11	85	M8×1	4.82×10 ⁻²	2.22	14.82	3137	2549				
75	110	130	16	113	20	93	11	85	M8×1	4.82×10 ⁻²	2.57	14.92	3137	2549				
75	110	128	16	111	20	93	11	85	M8×1	4.82×10 ⁻²	2.52	15.06	3137	2549				
75	110	107	16	90	20	93	11	85	M8×1	4.82×10 ⁻²	2.13	15.13	3137	2549				

Axial Clearance

Unit: mm

Clearance symbol	G0	GT
Axial Clearance	0 or less	0 to 0.005

Note) The overall length of the nut will increase when equipping the QZ lubricating device. See **A15-344** for further details. It is not possible to chamfer both ends of the screw shaft. When designing your system this way, contact THK.

The rigidity values (K) in the table represent spring constants, each obtained from the load and the elastic deformation under an axial load equal to 30% of the basic axial dynamic load rating (Ca).

These values do not include the rigidity of the components related to mounting the ball screw nut. Therefore, it is normally appropriate to regard roughly 80% of the rigidity value (K) in the table as the actual value.

If the axial load (Fa) is not 0.3 Ca, the rigidity value (K_n) is obtained from the following equation.

$$K_n = K \left(\frac{F_a}{0.3C_a} \right)^{\frac{1}{3}}$$

K: Rigidity value in the dimensional table.

HBN No Preload

DN value	130000
----------	--------

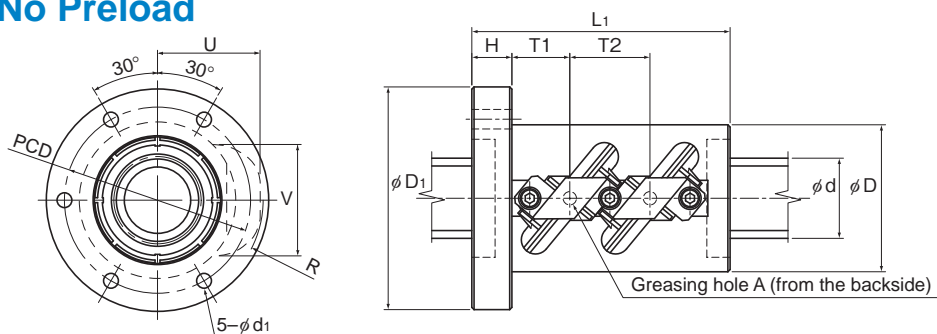

Models HBN3210 to 3612

Model No.	Screw shaft outer diameter d	Lead Ph	Ball center-to-center diameter dp	Thread minor diameter dc	No. of loaded circuits Rows × turns	Basic load rating		Permissible load* F _P kN	Rigidity K N/μm
						Ca kN	C _{0a} kN		
HBN 3210-5	32	10	34	26	2×2.5	102.9	191.3	31.9	1077
HBN 3610-5	36	10	38	30	2×2.5	108.2	220.4	33.5	1176
HBN 3612-5	36	12	38.4	29	2×2.5	141.1	267.7	43.7	1207
HBN 4010-7.5	40	10	42	34	3×2.5	162.6	336	50.4	1910
HBN 4012-7.5	40	12	42.4	33	3×2.5	212.4	441.6	65.8	1922
HBN 5010-7.5	50	10	52	44	3×2.5	179.1	462.7	55.5	2279
HBN 5012-7.5	50	12	52.4	43	3×2.5	235.7	572.2	73.1	2345
HBN 5016-7.5	50	16	53	39.6	3×2.5	379.6	820.9	117.7	2392
HBN 6316-7.5	63	16	66	52.6	3×2.5	427.1	1043.8	132.4	2898
HBN 6316-10.5	63	16	66	52.6	3×3.5	577.1	1461.3	178.9	4029
HBN 6320-7.5	63	20	66.5	49.6	3×2.5	578.8	1283.1	179.4	3030

*Ball screws with an outer screw shaft diameter (d) greater than 63 mm can also be manufactured.

Note) The permissible load F_P* indicates the maxim axial load that the Ball Screw can receive.

This model is capable of achieving a longer service life than the conventional Ball Screw under a high load.

Axial Clearance

Unit: mm

Clearance symbol	G2
Axial Clearance	0 to 0.02

Model number coding

HBN3210-5 RR G2 +1200L C7

Model number Seal symbol (*1)

Accuracy symbol (*2)

Overall screw shaft length (in mm)

Symbol for clearance in the axial direction

(For the axial clearance, this model has clearance G2 as standard.)

Other clearance is also available at your request. Contact THK for details.)

(*1) See [A15-336](#). (*2) See [A15-12](#).

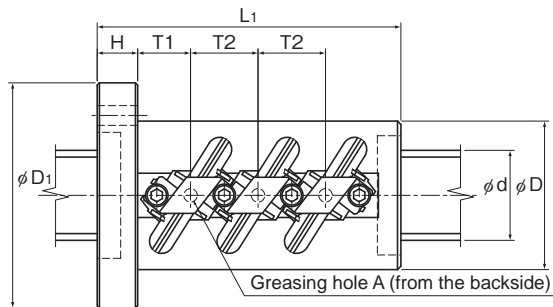

Models HBN4010 to 6320

Unit: mm

	Nut dimensions												Screw shaft inertial moment/mm kg-cm ² /mm	Nut mass kg	Shaft mass kg/m
	Outer diameter D	Flange diameter D ₁	Overall length L ₁	H	PCD	d ₁	T1	T2	U _{MAX}	V _{MAX}	R _{MAX}	Greasing hole			
58	85	98	15	71	6.6	22	30	43	46	43.5	M6	8.08 × 10 ⁻³	1.8	5.26	
62	89	98	15	75	6.6	22	30	45	50	46	M6	1.29 × 10 ⁻²	1.9	6.79	
66	100	116	18	82	9	26	36	49	52.5	50	M6	1.29 × 10 ⁻²	2.8	6.55	
66	100	135	18	82	9	23.5	30	46.5	54	48	M6	1.97 × 10 ⁻²	2.9	8.52	
70	104	152	18	86	9	26	36	51	56	52	M6	1.97 × 10 ⁻²	3.7	5.24	
78	112	135	18	94	9	23.5	30	52	63.5	54.5	M6	4.82 × 10 ⁻²	3.7	13.7	
80	114	152	18	96	9	26	36	56	66	58.5	M6	4.82 × 10 ⁻²	4.4	13.34	
95	135	211	28	113	9	37.5	48	64.5	69.6	65.2	PT 1/8	4.82 × 10 ⁻²	10.0	12.1	
105	139	211	28	122	9	37.5	48	70.5	82	72.5	PT 1/8	1.21 × 10 ⁻¹	10.6	20.2	
105	139	259	28	122	9	53.5	64	70.5	82	73	PT 1/8	1.21 × 10 ⁻¹	17.4	20.2	
117	157	252	32	137	11	44	60	79	86.5	80	PT 1/8	1.21 × 10 ⁻¹	17.2	19.13	

Note) The rigidity values in the table represent spring constants, each obtained from the load and the elastic deformation under an axial load equal to 30% of the basic axial dynamic load rating (Ca).

These values do not include the rigidity of the components related to mounting the ball screw nut. Therefore, it is normally appropriate to regard roughly 80% of the value in the table as the actual value.

If the axial load (Fa) is not 0.3 Ca, the rigidity value (K_n) is obtained from the following equation.

$$K_n = K \left(\frac{Fa}{0.3Ca} \right)^{\frac{1}{3}}$$

K: Rigidity value in the dimensional table.

SBKH No Preload

DN value	130000
----------	--------

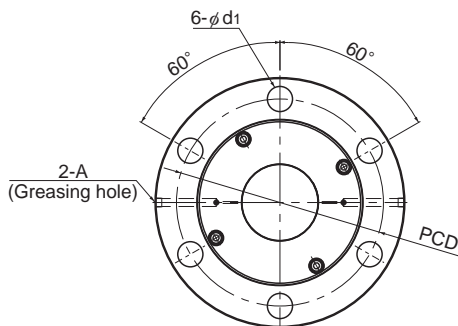

Model No.	Screw shaft outer diameter d	Lead Ph	Ball center-to-center diameter dp	Screw shaft Thread minor diameter dc	No. of loaded circuits Rows X turns	Basic load rating		Permissible load* Fp kN	Rigidity K N/μm
						Ca kN	C _{0a} kN		
SBKH 6332-3.8	63	32	66.5	49.8	1×3.8	304	631	88	1435
SBKH 6340-7.6	63	40	66.0	52.6	2×3.8	413	967	135	2723
SBKH 8050-7.6	80	50	84.0	63.6	2×3.8	777	1788	250	3402
SBKH 8060-7.6	80	60	84.0	63.6	2×3.8	780	1824	255	3452
SBKH 10050-7.6	100	50	104.0	83.6	2×3.8	876	2401	336	4098
SBKH 10060-7.6	100	60	104.0	83.6	2×3.8	880	2294	321	4149
SBKH 12060-7.6	120	60	124.0	103.6	2×3.8	962	2941	411	4809

Note) The permissible load Fp* indicates the maximum axial load that the Ball Screw can receive.
If desiring both ends of the screw shaft to be larger than the screw shaft diameter, contact THK.

Axial Clearance

Unit: mm

Clearance symbol	G1	G2	G3
Axial Clearance	0 to 0.01	0 to 0.02	0 to 0.05

Model number coding

SBKH8050-7.6 RR G2 +1200L C7

Model Number

Accuracy symbol (*2)

Overall screw shaft length (in mm)

Axial clearance symbol
(clearance in the axial direction must be: G1, G2 or G3.
Clearance G0 and GT are not supported.)

Seal symbol(*1)

(RR: labyrinth seal on both sides)

(*1) See **A15-336**. (*2) See **A15-12**.

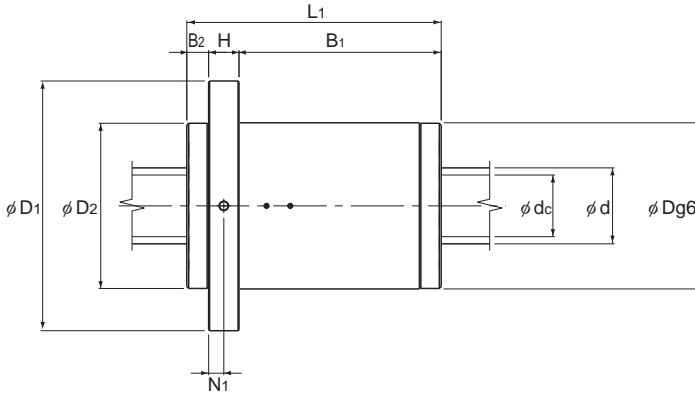

Unit: mm

	Nut dimensions											Screw shaft inertial moment/mm kg-cm ² /mm	Nut mass kg	Shaft mass* kg/m
	Outer diameter D	Flange diameter D ₁	Cap diameter D ₂	Overall length L ₁	H	B ₁	B ₂	PCD	d _i	N _i	Greasing hole A			
	140	205	(140)	190	28	143	(19)	173	22	14	PT1/8	1.21 × 10 ⁻¹	17.2	21.0
	127	191	(127)	209	30	163	(16)	159	22	15	PT1/8	1.21 × 10 ⁻¹	15.5	21.0
	175	253	(175)	268	32	213	(23)	214	26	16	PT1/8	3.16 × 10 ⁻¹	36.9	31.3
	175	253	(175)	306	40	243	(23)	214	26	20	PT1/8	3.16 × 10 ⁻¹	43.5	32.5
	195	273	(195)	269	40	206	(23)	234	26	20	PT1/8	7.71 × 10 ⁻¹	44.5	51.3
	195	273	(195)	307	40	244	(23)	234	26	20	PT1/8	7.71 × 10 ⁻¹	50.5	52.9
	210	288	(210)	308	45	240	(23)	249	26	22.5	PT1/8	1.60	53.7	78.1

Note1) There will be no dimensional change after the seal is attached.

Note2) The rigidity values (K) in the table represent spring constants, each obtained from the load and the elastic deformation under an axial load equal to 30% of the basic axial dynamic load rating (Ca).

These values do not include the rigidity of the components related to mounting the ball screw nut. Therefore, it is normally appropriate to regard roughly 80% of the rigidity value (K) in the table as the actual value.

If the axial load (Fa) is not 0.3 Ca, the rigidity value (K_N) is obtained from the following equation.

$$K_N = K \left(\frac{F_a}{0.3Ca} \right)^{\frac{1}{3}}$$

K: Rigidity value in the dimensional table.

DIN Standard compliant Ball Screw (DIN69051)

Models EBA, EBB, EBC, EPA, EPB and EPC

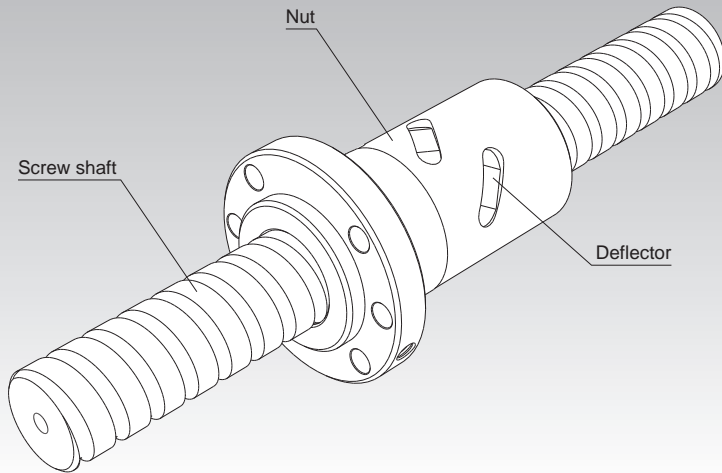

Fig.1 DIN Standard (DIN69051) Compliant Precision Ball Screw

Point of Selection	A15-8
Options	A15-336
Model No.	A15-353
Precautions on Use	A15-358
Accessories for Lubrication	A24-1
Mounting Procedure and Maintenance	B15-104
Lead Angle Accuracy	A15-11
Accuracy of the Mounting Surface	A15-14
Axial Clearance	A15-19
Maximum Length of the Screw Shaft	A15-24
DN Value	A15-33
Support Unit	A15-300
Recommended Shapes of Shaft Ends	A15-308
Dimensions of Each Model with an Option Attached	A15-344

Structure and Features

In the DIN standard compliant Ball Screw, balls under a load roll in the raceway cut between the screw shaft and the nut while receiving the axial load, travel along the groove of a deflector embedded inside the nut to the adjacent raceway, and then circulate back to the loaded area. Thus, the balls perform infinite rolling motion.

Two types of nuts are available: model EB of oversized-ball preload type or non-preloaded type, and model EP of offset preloaded type.

[Compact]

This Ball Screw is compactly built. Because of an internal circulation system using deflectors, the outer diameter of the nut is 70 to 80% of the conventional double nut and the overall nut length is only 60 to 80% of the return pipe nut.

[Compliant with a DIN standard]

The nut flange shape, mounting holes and rated load are compliant with DIN69051.

Types and Features

Models EPA/EBA

[Flange shape: round-flange type]

Specification Table⇒ [A15-100](#)/[A15-94](#)

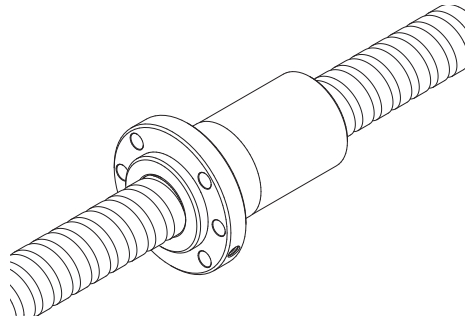

Models EPB/EBB

[Flange shape: type with two cut faces]

Specification Table⇒ [A15-102](#)/[A15-96](#)

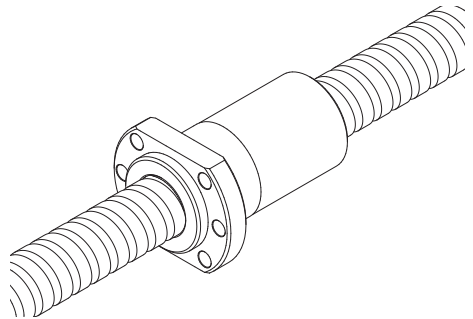

Models EPC/EBC

[Flange shape: type with one cut face]

Specification Table⇒ [A15-104](#)/[A15-98](#)

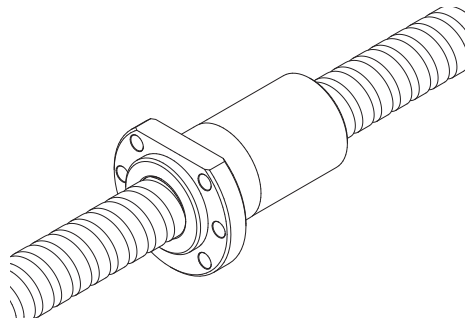

Accuracy Standards

The accuracy of DIN standard compliant Ball Screw is controlled in accordance with ISO standard (ISO3408-3) and JIS standard (JIS B1192-1997). C, Cp and Ct grades are defined for this Ball Screw series.

Grade C (see page **A15-11**)

Grade Cp, Ct (see ISO 3408-3)

Grade	0	1	2	3	5	7
C	○	○	○	○	○	○
Cp	—	—	—	○	○	—
Ct	—	—	—	○	○	○

EBA

Oversized-ball Preload / No Preload

DN value	100000
----------	--------

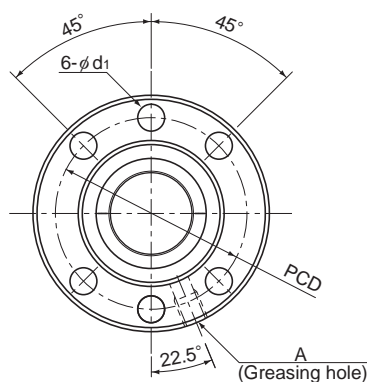

Hole type 1
(Model EBA1605 to 3210)

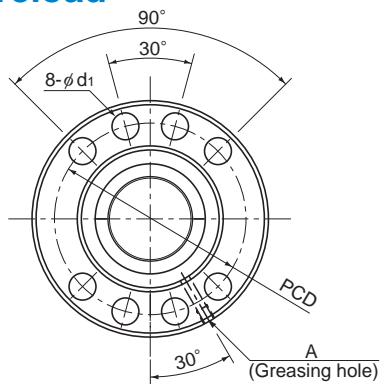

Hole type 2
(Model EBA4005 to 6320)

Model No.	Screw shaft outer diameter d	Lead ℓ	Ball center-to-center diameter dp	Thread minor diameter dc	No. of loaded circuits Rows x turns	Basic load rating		Rigidity K N/ μ m
						Ca*	Ca	
EBA 1605-4	16	5	16.75	13.1	4×1	11.9	17.4	210
EBA 2005-3	20	5	20.75	17.1	3×1	10.6	17.3	200
EBA 2505-3	25	5	25.75	22.1	3×1	12.1	22.6	250
EBA 2510-3	25	10	26	21.6	3×1	15.9	27	250
EBA 2510-4	25	10	26	21.6	4×1	20.9	37.6	330
EBA 3205-3	32	5	32.75	29.2	3×1	13.9	30.2	300
EBA 3205-4	32	5	32.75	29.2	4×1	17.8	40.3	400
EBA 3205-6	32	5	32.75	29.2	6×1	25.1	60.4	600
EBA 3210-3	32	10	33.75	26.4	3×1	32.1	52.2	300
EBA 3210-4	32	10	33.75	26.4	4×1	41.3	69.7	390
EBA 4005-6	40	5	40.75	37.1	6×1	26.6	77.5	716
EBA 4010-3	40	10	41.75	34.4	3×1	37.3	69.3	380
EBA 4010-4	40	10	41.75	34.4	4×1	47.6	92.4	500
EBA 4020-3	40	20	41.75	34.7	3×1	36.8	69.3	750
EBA 5010-4	50	10	51.75	44.4	4×1	54.3	120.5	610
EBA 5020-3	50	20	52.25	43.6	3×1	55.3	108.8	470
EBA 6310-6	63	10	64.75	57.7	6×1	87.9	242.1	1140
EBA 6320-3	63	20	65.7	56.0	3×1	104.4	229.3	1470

Note) ★ Basic Dynamic Load Rating(Ca) of the accuracy C7 and Ct7 is 0.9Ca.

Model number coding

EB A 20 05 -6 QZ RR G0 +650L C3

EB: Flange shape: A: round; B: double chamfered; C: single chamfered
 A: Shaft diameter
 20: Number of turns
 05: Lead
 -6: Clearance symbol
 QZ: Seal symbol (RR : Labyrinth seal, WW : Wiper ring.)
 RR: With QZ Lubricator (no symbol without QZ Lubricator)
 G0: Ball screw shaft length (mm)
 +650L: Accuracy symbol
 C3: Nut type: oversized-ball preload type or non-preloaded type

DIN Standard compliant Ball Screw (DIN69051)

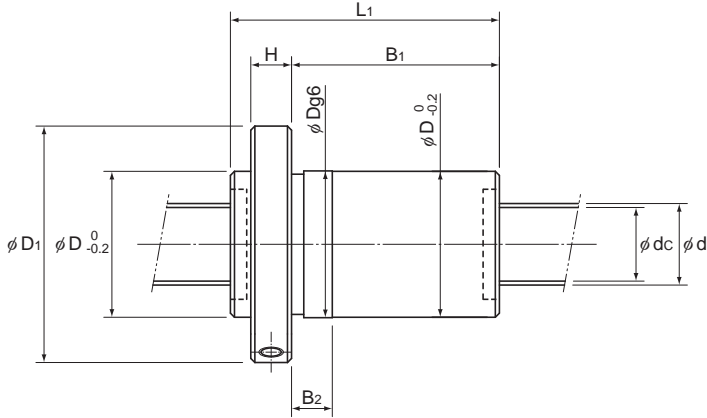

Unit: mm

Nut dimensions										
Outer diameter	Flange diameter	Overall length					Hole type	PCD	d ₁	Greasing hole
D	D ₁	L ₁	H	B ₁	B ₂					A
28	48	55	10	40	12		1	38	5.5	M6×1
36	58	50	10	35	12		1	47	6.6	M6×1
40	62	50	10	35	12		1	51	6.6	M6×1
40	62	80	10	65	18		1	51	6.6	M6×1
40	62	85	10	70	18		1	51	6.6	M6×1
50	80	52	12	35	12		1	65	9	M6×1
50	80	57	12	40	12		1	65	9	M6×1
50	80	67	12	50	12		1	65	9	M6×1
50	80	82	12	65	18		1	65	9	M6×1
50	80	94	12	77	18		1	65	9	M6×1
63	93	70	14	51	12		2	78	9	M8×1
63	93	84	14	65	18		2	78	9	M8×1
63	93	94	14	75	18		2	78	9	M8×1
63	93	129	14	105	25		2	78	9	M8×1
75	110	96	16	75	18		2	93	11	M8×1
75	110	134	16	108	27		2	93	11	M8×1
90	125	119	18	96	18		2	108	11	M8×1
95	135	136	18	108	27		2	115	13.5	M8×1

Note) The rigidity values in the table represent spring constants each obtained from the load and the Elastic Deformation finish when providing an axial load 24% of the basic dynamic load rating (Ca).

These values do not include the rigidity of the components related to mounting the nut. Therefore, it is normally appropriate to regard roughly 80% of the value in the table as the actual value.

If the axial load (Fa) is not 0.24 Ca, the rigidity value (K_N) is obtained from the following equation.

$$K_N = K \left(\frac{Fa}{0.24Ca} \right)^{\frac{1}{3}}$$

K: Rigidity value in the dimensional table.

EBB

Oversized-ball Preload / No Preload

DN value	100000
----------	--------

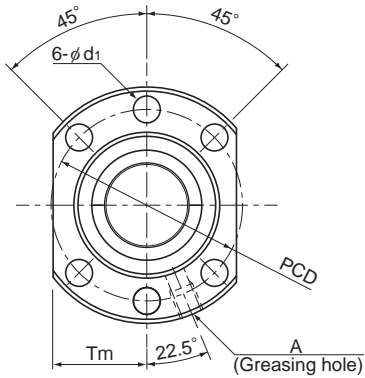

Hole type 1
(Model EBB1605 to 3210)

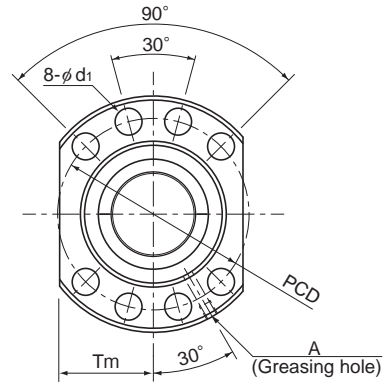

Hole type 2
(Model EBB4005 to 6320)

Model No.	Screw shaft outer diameter d	Lead ℓ	Ball center-to-center diameter dp	Thread minor diameter d _c	No. of loaded circuits Rows x turns	Basic load rating		Rigidity K N/μm
						Ca* kN	C _{0a} kN	
EBB 1605-4	16	5	16.75	13.1	4×1	11.9	17.4	210
EBB 2005-3	20	5	20.75	17.1	3×1	10.6	17.3	200
EBB 2505-3	25	5	25.75	22.1	3×1	12.1	22.6	250
EBB 2510-3	25	10	26	21.6	3×1	15.9	27	250
EBB 2510-4	25	10	26	21.6	4×1	20.9	37.6	330
EBB 3205-3	32	5	32.75	29.2	3×1	13.9	30.2	300
EBB 3205-4	32	5	32.75	29.2	4×1	17.8	40.3	400
EBB 3205-6	32	5	32.75	29.2	6×1	25.1	60.4	600
EBB 3210-3	32	10	33.75	26.4	3×1	32.1	52.2	300
EBB 3210-4	32	10	33.75	26.4	4×1	41.3	69.7	390
EBB 4005-6	40	5	40.75	37.1	6×1	26.6	77.5	716
EBB 4010-3	40	10	41.75	34.4	3×1	37.3	69.3	380
EBB 4010-4	40	10	41.75	34.4	4×1	47.6	92.4	500
EBB 4020-3	40	20	41.75	34.7	3×1	36.8	69.3	750
EBB 5010-4	50	10	51.75	44.4	4×1	54.3	120.5	610
EBB 5020-3	50	20	52.25	43.6	3×1	55.3	108.8	470
EBB 6310-6	63	10	64.75	57.7	6×1	87.9	242.1	1140
EBB 6320-3	63	20	65.7	56.0	3×1	104.4	229.3	1470

Note) ★ Basic Dynamic Load Rating(Ca) of the accuracy C7 and C7t is 0.9Ca.

Model number coding

EB B 20 05 -6 QZ RR G0 +650L C3

Shaft diameter Number of turns Clearance symbol Accuracy symbol

Lead

Ball screw shaft length (mm)

Seal symbol (RR : Labyrinth seal, WW : Wiper ring.)

With QZ Lubricator (no symbol without QZ Lubricator)

Flange shape: A: round; B: double chamfered; C: single chamfered

Nut type: oversized-ball preload type or non-preloaded type

DIN Standard compliant Ball Screw (DIN69051)

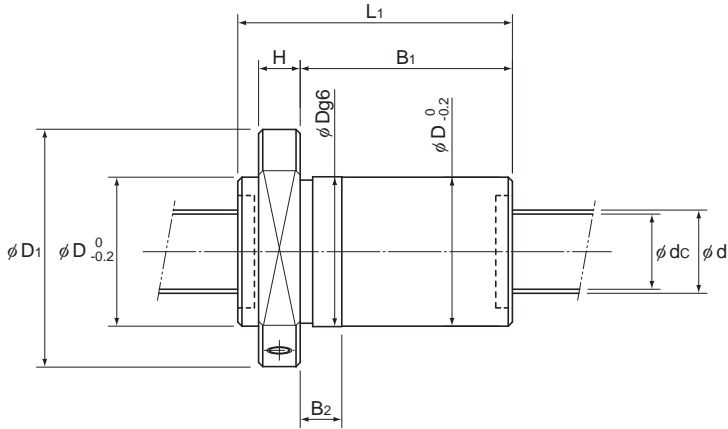

Unit: mm

Nut dimensions											
Outer diameter	Flange diameter	Overall length					Hole type	PCD	d ₁	T _m	Greasing hole
D	D ₁	L ₁	H	B ₁	B ₂						A
28	48	55	10	40	12	1	38	5.5	20	M6×1	
36	58	50	10	35	12	1	47	6.6	22	M6×1	
40	62	50	10	35	12	1	51	6.6	24	M6×1	
40	62	80	10	65	18	1	51	6.6	24	M6×1	
40	62	85	10	70	18	1	51	6.6	24	M6×1	
50	80	52	12	35	12	1	65	9	31	M6×1	
50	80	57	12	40	12	1	65	9	31	M6×1	
50	80	67	12	50	12	1	65	9	31	M6×1	
50	80	82	12	65	18	1	65	9	31	M6×1	
50	80	94	12	77	18	1	65	9	31	M6×1	
63	93	70	14	51	12	2	78	9	35	M8×1	
63	93	84	14	65	18	2	78	9	35	M8×1	
63	93	94	14	75	18	2	78	9	35	M8×1	
63	93	129	14	105	25	2	78	9	35	M8×1	
75	110	96	16	75	18	2	93	11	42.5	M8×1	
75	110	134	16	108	27	2	93	11	42.5	M8×1	
90	125	119	18	96	18	2	108	11	47.5	M8×1	
95	135	136	18	108	27	2	115	13.5	50	M8×1	

Note) The rigidity values in the table represent spring constants each obtained from the load and the Elastic Deformation finish when providing an axial load 24% of the basic dynamic load rating (Ca).

These values do not include the rigidity of the components related to mounting the nut. Therefore, it is normally appropriate to regard roughly 80% of the value in the table as the actual value.

If the axial load (Fa) is not 0.24 Ca, the rigidity value (K_N) is obtained from the following equation.

$$K_N = K \left(\frac{Fa}{0.24Ca} \right)^{\frac{1}{3}}$$

K: Rigidity value in the dimensional table.

EBC

Oversized-ball Preload / No Preload

DN value	100000
----------	--------

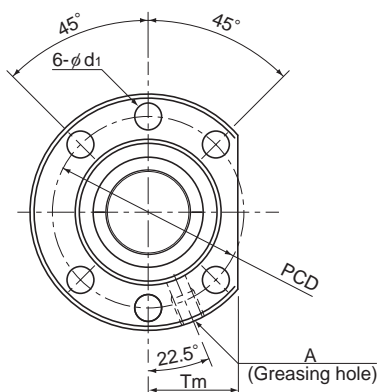

Hole type 1
(Model EBC1605 to 3210)

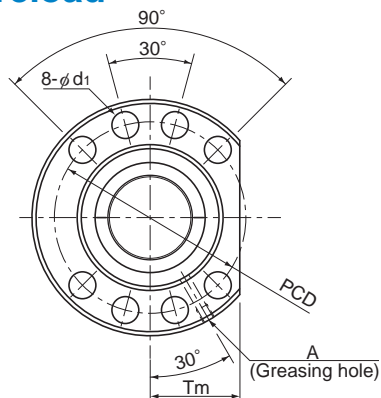

Hole type 2
(Model EBC4005 to 6320)

Model No.	Screw shaft outer diameter d	Lead ℓ	Ball center-to-center diameter dp	Thread minor diameter dc	No. of loaded circuits Rows x turns	Basic load rating		Rigidity K N/ μ m
						Ca*	Ca	
EBC 1605-4	16	5	16.75	13.1	4×1	11.9	17.4	210
EBC 2005-3	20	5	20.75	17.1	3×1	10.6	17.3	200
EBC 2505-3	25	5	25.75	22.1	3×1	12.1	22.6	250
EBC 2510-3	25	10	26	21.6	3×1	15.9	27	250
EBC 2510-4	25	10	26	21.6	4×1	20.9	37.6	330
EBC 3205-3	32	5	32.75	29.2	3×1	13.9	30.2	300
EBC 3205-4	32	5	32.75	29.2	4×1	17.8	40.3	400
EBC 3205-6	32	5	32.75	29.2	6×1	25.1	60.4	600
EBC 3210-3	32	10	33.75	26.4	3×1	32.1	52.2	300
EBC 3210-4	32	10	33.75	26.4	4×1	41.3	69.7	390
EBC 4005-6	40	5	40.75	37.1	6×1	26.6	77.5	716
EBC 4010-3	40	10	41.75	34.4	3×1	37.3	69.3	380
EBC 4010-4	40	10	41.75	34.4	4×1	47.6	92.4	500
EBC 4020-3	40	20	41.75	34.7	3×1	36.8	69.3	750
EBC 5010-4	50	10	51.75	44.4	4×1	54.3	120.5	610
EBC 5020-3	50	20	52.25	43.6	3×1	55.3	108.8	470
EBC 6310-6	63	10	64.75	57.7	6×1	87.9	242.1	1140
EBC 6320-3	63	20	65.7	56.0	3×1	104.4	229.3	1470

Note) ★ Basic Dynamic Load Rating(Ca) of the accuracy C7 and Ct7 is 0.9Ca.

Model number coding

EB C 20 05 -6 QZ RR G0 +650L C3

EB: Flange shape: A: round; B: double chamfered; C: single chamfered
 C: Shaft diameter
 20: Lead
 05: Number of turns
 -6: Clearance symbol
 QZ: Seal symbol (RR : Labyrinth seal, WW : Wiper ring.)
 RR: With QZ Lubricator (no symbol without QZ Lubricator)
 G0: Ball screw shaft length (mm)
 +650L: Accuracy symbol
 C3: Nut type: oversized-ball preload type or non-preloaded type

DIN Standard compliant Ball Screw (DIN69051)

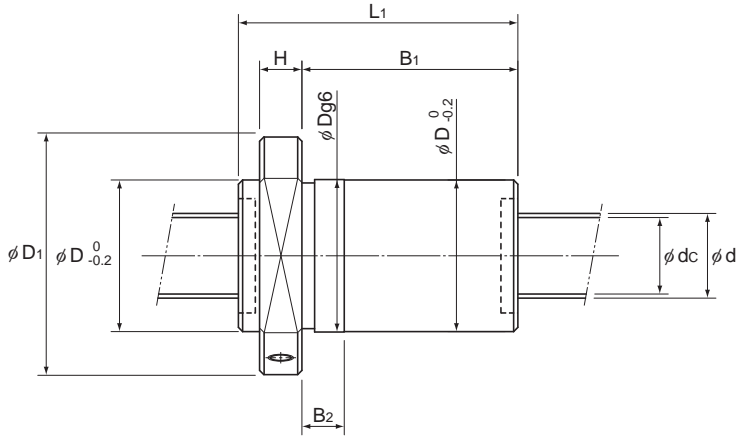

Unit: mm

Nut dimensions											
Outer diameter	Flange diameter	Overall length					Hole type	PCD	d ₁	Tm	Greasing hole
D	D ₁	L ₁	H	B ₁	B ₂						A
28	48	55	10	40	12	1	38	5.5	20	M6×1	
36	58	50	10	35	12	1	47	6.6	22	M6×1	
40	62	50	10	35	12	1	51	6.6	24	M6×1	
40	62	80	10	65	18	1	51	6.6	24	M6×1	
40	62	85	10	70	18	1	51	6.6	24	M6×1	
50	80	52	12	35	12	1	65	9	31	M6×1	
50	80	57	12	40	12	1	65	9	31	M6×1	
50	80	67	12	50	12	1	65	9	31	M6×1	
50	80	82	12	65	18	1	65	9	31	M6×1	
50	80	94	12	77	18	1	65	9	31	M6×1	
63	93	70	14	51	12	2	78	9	35	M8×1	
63	93	84	14	65	18	2	78	9	35	M8×1	
63	93	94	14	75	18	2	78	9	35	M8×1	
63	93	129	14	105	25	2	78	9	35	M8×1	
75	110	96	16	75	18	2	93	11	42.5	M8×1	
75	110	134	16	108	27	2	93	11	42.5	M8×1	
90	125	119	18	96	18	2	108	11	47.5	M8×1	
95	135	136	18	108	27	2	115	13.5	50	M8×1	

Note) The rigidity values in the table represent spring constants each obtained from the load and the Elastic Deformation finish when providing an axial load 24% of the basic dynamic load rating (Ca).

These values do not include the rigidity of the components related to mounting the nut. Therefore, it is normally appropriate to regard roughly 80% of the value in the table as the actual value.

If the axial load (Fa) is not 0.24 Ca, the rigidity value (K_N) is obtained from the following equation.

$$K_N = K \left(\frac{F_a}{0.24 C_a} \right)^3$$

K: Rigidity value in the dimensional table.

EPA With Preload

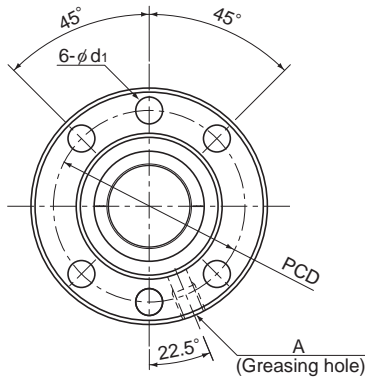

Hole type 1
(Model EPA1605 to 3210)

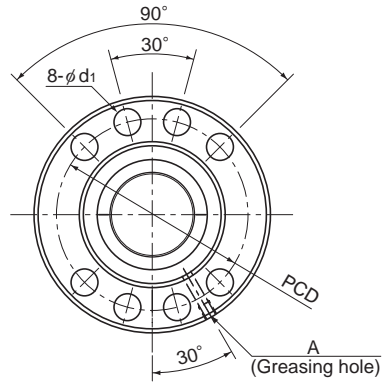

Hole type 2
(Model EPA4005 to 6310)

Model No.	Screw shaft outer diameter d	Lead ℓ	Ball center-to-center diameter dp	Thread minor diameter dc	No. of loaded circuits Rows x turns	Basic load rating		Rigidity K N/ μ m
						Ca*	Ca	
EPA 1605-6	16	5	16.75	13.1	3×1	9.3	13.1	317
EPA 2005-6	20	5	20.75	17.1	3×1	10.6	17.3	310
EPA 2505-6	25	5	25.75	22.1	3×1	12.1	22.6	490
EPA 2510-4	25	10	26	21.6	2×1	11.3	18	330
EPA 3205-6	32	5	32.75	29.2	3×1	13.9	30.2	620
EPA 3205-8	32	5	32.75	29.2	4×1	17.8	40.3	810
EPA 3210-6	32	10	33.75	26.4	3×1	32.1	52.2	600
EPA 4005-6	40	5	40.75	37.1	3×1	15.4	38.8	298
EPA 4010-6	40	10	41.75	34.7	3×1	37.3	69.3	750
EPA 4010-8	40	10	41.75	34.7	4×1	47.6	92.4	1000
EPA 5010-8	50	10	51.75	44.4	4×1	54.3	120.5	1230
EPA 6310-8	63	10	64.75	57.7	4×1	61.9	160.7	1550

Note) ★ Basic Dynamic Load Rating(Ca) of the accuracy C7 and Ct7 is 0.9Ca.

Model number coding

EP A 20 05 -6 QZ RR G0 +650L C3

EP: Flange shape: A: round; B: double chamfered; C: single chamfered
 A: Shaft diameter
 20: Number of turns
 05: Lead
 -6: Clearance symbol
 QZ: Seal symbol (RR : Labyrinth seal, WW : Wiper ring.)
 RR: With QZ Lubricator (no symbol without QZ Lubricator)
 G0: Ball screw shaft length (mm)
 +650L: Accuracy symbol
 C3: Nut type: offset preloaded type

DIN Standard compliant Ball Screw (DIN69051)

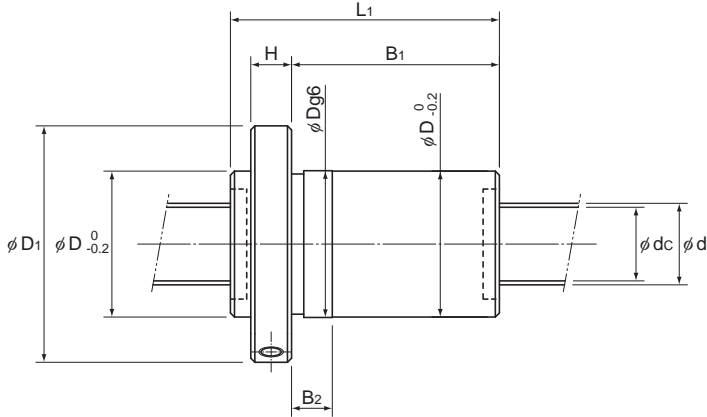

Unit: mm

Nut dimensions										
Outer diameter	Flange diameter	Overall length				Hole type	PCD			Greasing hole
D	D ₁	L ₁	H	B ₁	B ₂			d ₁		A
28	48	65	10	50	12	1	38	5.5		M6×1
36	58	66	10	51	12	1	47	6.6		M6×1
40	62	66	10	51	12	1	51	6.6		M6×1
40	62	85	10	70	18	1	51	6.6		M6×1
50	80	67	12	50	12	1	65	9		M6×1
50	80	78	12	61	12	1	65	9		M6×1
50	80	112	12	95	18	1	65	9		M6×1
63	93	70	14	51	12	2	78	9		M8×1
63	93	114	14	95	18	2	78	9		M8×1
63	93	138	14	119	18	2	78	9		M8×1
75	110	140	16	119	18	2	93	11		M8×1
90	125	142	18	119	18	2	108	11		M8×1

Note) The rigidity values in the table represent spring constants each obtained from the load and the elastic deformation when providing a preload 8% of the basic dynamic load rating (Ca) and applying an axial load three times greater than the preload. These values do not include the rigidity of the components related to mounting the nut. Therefore, it is normally appropriate to regard roughly 80% of the value in the table as the actual value.

If the applied preload (Fa0) is not 0.08 Ca, the rigidity value (K_n) is obtained from the following equation.

$$K_n = K \left(\frac{Fa0}{0.08Ca} \right)^{\frac{1}{3}}$$

K: Rigidity value in the dimensional table.

EPB With Preload

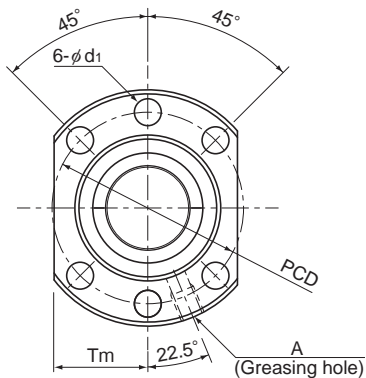

Hole type 1
(Model EPB1605 to 3210)

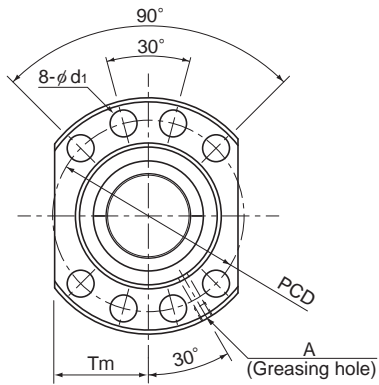

Hole type 2
(Model EPB4005 to 6310)

Model No.	Screw shaft outer diameter d	Lead ℓ	Ball center-to-center diameter dp	Thread minor diameter dc	No. of loaded circuits Rows x turns	Basic load rating		Rigidity K N/ μ m
						Ca*	Ca	
EPB 1605-6	16	5	16.75	13.1	3×1	9.3	13.1	317
EPB 2005-6	20	5	20.75	17.1	3×1	10.6	17.3	310
EPB 2505-6	25	5	25.75	22.1	3×1	12.1	22.6	490
EPB 2510-4	25	10	26	21.6	2×1	11.3	18	330
EPB 3205-6	32	5	32.75	29.2	3×1	13.9	30.2	620
EPB 3205-8	32	5	32.75	29.2	4×1	17.8	40.3	810
EPB 3210-6	32	10	33.75	26.4	3×1	32.1	52.2	600
EPB 4005-6	40	5	40.75	37.1	3×1	15.4	38.8	298
EPB 4010-6	40	10	41.75	34.7	3×1	37.3	69.3	750
EPB 4010-8	40	10	41.75	34.7	4×1	47.6	92.4	1000
EPB 5010-8	50	10	51.75	44.4	4×1	54.3	120.5	1230
EPB 6310-8	63	10	64.75	57.7	4×1	61.9	160.7	1550

Note) ★ Basic Dynamic Load Rating(Ca) of the accuracy C7 and Ct7 is 0.9Ca.

Model number coding

EP B 20 05 -6 QZ RR G0 +650L C3

EP: Flange shape: A: round; B: double chamfered; C: single chamfered
 B: Shaft diameter
 20: Ball screw shaft length (mm)
 05: Lead
 -6: Number of turns
 QZ: Seal symbol (RR : Labyrinth seal, WW : Wiper ring.)
 RR: With QZ Lubricator (no symbol without QZ Lubricator)
 G0: Clearance symbol
 +650L: Accuracy symbol
 C3: Nut type: offset preloaded type

DIN Standard compliant Ball Screw (DIN69051)

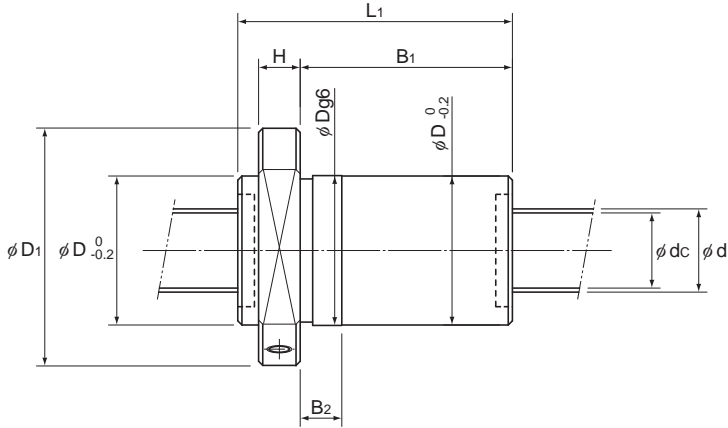

Unit: mm

Nut dimensions											
Outer diameter	Flange diameter	Overall length					Hole type	PCD	d_1	Tm	Greasing hole
D	D ₁	L ₁	H	B ₁	B ₂						A
28	48	65	10	50	12		1	38	5.5	20	M6×1
36	58	66	10	51	12		1	47	6.6	22	M6×1
40	62	66	10	51	12		1	51	6.6	24	M6×1
40	62	85	10	70	18		1	51	6.6	24	M6×1
50	80	67	12	50	12		1	65	9	31	M6×1
50	80	78	12	61	12		1	65	9	31	M6×1
50	80	112	12	95	18		1	65	9	31	M6×1
63	93	70	14	51	12		2	78	9	35	M8×1
63	93	114	14	95	18		2	78	9	35	M8×1
63	93	138	14	119	18		2	78	9	35	M8×1
75	110	140	16	119	18		2	93	11	42.5	M8×1
90	125	142	18	119	18		2	108	11	47.5	M8×1

Note) The rigidity values in the table represent spring constants each obtained from the load and the elastic deformation when providing a preload 8% of the basic dynamic load rating (Ca) and applying an axial load three times greater than the preload. These values do not include the rigidity of the components related to mounting the nut. Therefore, it is normally appropriate to regard roughly 80% of the value in the table as the actual value.

If the applied preload (Fa0) is not 0.08 Ca, the rigidity value (K_N) is obtained from the following equation.

$$K_N = K \left(\frac{Fa_0}{0.08Ca} \right)^{\frac{1}{3}}$$

K: Rigidity value in the dimensional table.

EPC With Preload

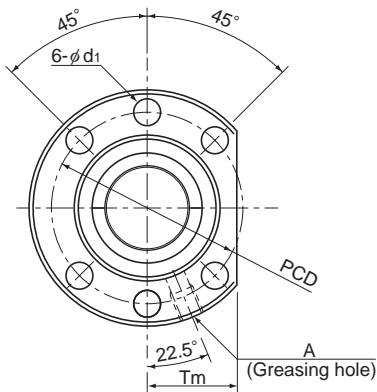

Hole type 1
(Model EPC1605 to 3210)

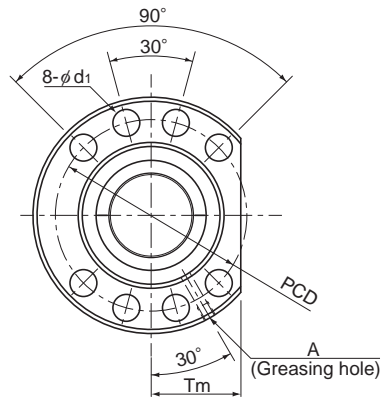

Hole type 2
(Model EPC4005 to 6310)

Model No.	Screw shaft outer diameter d	Lead ℓ	Ball center-to-center diameter dp	Thread minor diameter dc	No. of loaded circuits Rows x turns	Basic load rating		Rigidity K N/μm
						Ca*	C _a	
EPC 1605-6	16	5	16.75	13.1	3×1	9.3	13.1	317
EPC 2005-6	20	5	20.75	17.1	3×1	10.6	17.3	310
EPC 2505-6	25	5	25.75	22.1	3×1	12.1	22.6	490
EPC 2510-4	25	10	26	21.6	2×1	11.3	18	330
EPC 3205-6	32	5	32.75	29.2	3×1	13.9	30.2	620
EPC 3205-8	32	5	32.75	29.2	4×1	17.8	40.3	810
EPC 3210-6	32	10	33.75	26.4	3×1	32.1	52.2	600
EPC 4005-6	40	5	40.75	37.1	3×1	15.4	38.8	298
EPC 4010-6	40	10	41.75	34.7	3×1	37.3	69.3	750
EPC 4010-8	40	10	41.75	34.7	4×1	47.6	92.4	1000
EPC 5010-8	50	10	51.75	44.4	4×1	54.3	120.5	1230
EPC 6310-8	63	10	64.75	57.7	4×1	61.9	160.7	1550

Note) ★ Basic Dynamic Load Rating(Ca) of the accuracy C7 and Ct7 is 0.9Ca.

Model number coding

EP C 20 05 -6 QZ RR G0 +650L C3

EP: Flange shape: A: round; B: double chamfered; C: single chamfered
 C: Nut type: offset preloaded type
 20: Shaft diameter
 05: Number of turns
 -6: Lead
 QZ: Seal symbol (RR: Labyrinth seal, WW: Wiper ring.)
 RR: With QZ Lubricator (no symbol without QZ Lubricator)
 G0: Clearance symbol
 +650L: Ball screw shaft length (mm)
 C3: Accuracy symbol

DIN Standard compliant Ball Screw (DIN69051)

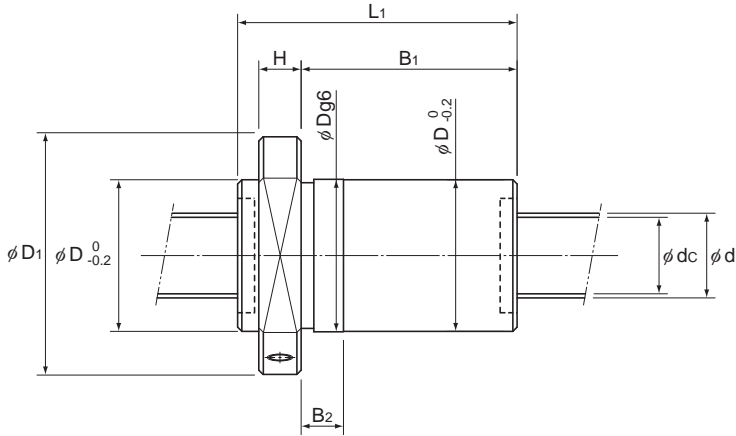

Unit: mm

Nut dimensions											
Outer diameter	Flange diameter	Overall length	H	B ₁	B ₂	Hole type	PCD	d ₁	T _m	Greasing hole	
D	D ₁	L ₁								A	
28	48	65	10	50	12	1	38	5.5	20	M6×1	
36	58	66	10	51	12	1	47	6.6	22	M6×1	
40	62	66	10	51	12	1	51	6.6	24	M6×1	
40	62	85	10	70	18	1	51	6.6	24	M6×1	
50	80	67	12	50	12	1	65	9	31	M6×1	
50	80	78	12	61	12	1	65	9	31	M6×1	
50	80	112	12	95	18	1	65	9	31	M6×1	
63	93	70	14	51	12	2	78	9	35	M8×1	
63	93	114	14	95	18	2	78	9	35	M8×1	
63	93	138	14	119	18	2	78	9	35	M8×1	
75	110	140	16	119	18	2	93	11	42.5	M8×1	
90	125	142	18	119	18	2	108	11	47.5	M8×1	

Note) The rigidity values in the table represent spring constants each obtained from the load and the elastic deformation when providing a preload 8% of the basic dynamic load rating (Ca) and applying an axial load three times greater than the preload. These values do not include the rigidity of the components related to mounting the nut. Therefore, it is normally appropriate to regard roughly 80% of the value in the table as the actual value.

If the applied preload (Fa0) is not 0.08 Ca, the rigidity value (K_N) is obtained from the following equation.

$$K_N = K \left(\frac{Fa_0}{0.08Ca} \right)^3$$

K: Rigidity value in the dimensional table.

Unfinished Shaft Ends Precision Ball Screw

Models BIF, MDK, MBF and BNF

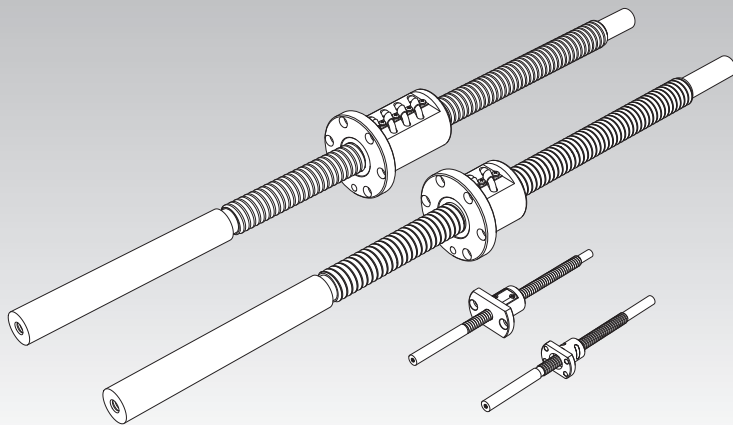

Point of Selection **A15-8**

Options **A15-336**

Model No. **A15-353**

Precautions on Use **A15-358**

Accessories for Lubrication **A24-1**

Mounting Procedure and Maintenance **B15-104**

Lead Angle Accuracy **A15-11**

Accuracy of the Mounting Surface **A15-14**

Axial clearance **A15-109**

DN Value **A15-33**

Support Unit **A15-300**

Recommended Shapes of Shaft Ends **A15-308**

Structure and Features

This type of ball screw is mass produced by cutting the standard screw shafts of precision ball screws to regular lengths.

Additional machining of the shaft ends can be performed easily.

To meet various intended purposes, THK offers several Ball Screw models with different types of nuts: the single-nut type (model BNF), the offset preload-nut type (model BIF) and the miniature Ball Screw (models MDK and MBF).

[Contamination Protection]

Nuts of the following model numbers are attached with a labyrinth seal.

- All variations of models BNF and BIF
- Model MDK0802/1002/1202/1402/1404/1405

When dust or other foreign material may enter the Ball Screw, it is necessary to use a contamination protection device (e.g., bellows) to completely protect the screw shaft.

[Lubrication]

The ball screw nuts are supplied with lithium soap-group grease with shipments.

(Models MDK and MBF are applied only with an anti-rust oil.)

[Additional Machining of the Shaft End]

Since only the effective thread of the screw shaft is surface treated with induction-hardening (all variations of models BNF and BIF; model MDK 1405) or carburizing (all variations of model MBF; model MDK0401 to 1404), the shaft ends can additionally be machined easily either by grinding or milling.

In addition, since both ends of the screw shaft have a center hole, they can be cylindrically ground.

Surface hardness of the effective thread : 58 to 64 HRC

Hardness of the screw shaft ends

All variations of models BNF and BIF; model MDK 1405 : 22 to 27 HRC

All variations of model MBF; model MDK0401 to 1404 : 35 HRC or below

THK has standardized the shapes of the screw shaft ends in order to allow speedy estimation and manufacturing of the Ball Screws.

The shapes of shaft ends are divided into those allowing the standard support units to be used (symbols H, K and J) and those compliant with JIS B 1192-1997 (symbols A, B and C). See **A15-308** for details.

Types and Features

[Preload Type]

Model BIF

Specification Table⇒ **A15-116**

The right and left screws are provided with a phase in the middle of the ball screw nut, and an axial clearance is set at a below-zero value (under a preload). This compact model is capable of a smooth motion.

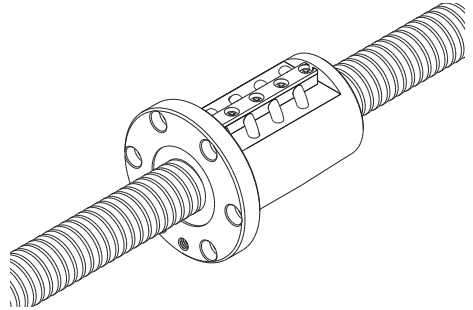

[No Preload Type]

Models MDK and MBF

Specification Table⇒ **A15-110/A15-114**

A miniature type with a screw shaft diameter of $\phi 4$ to $\phi 14$ mm and a lead of 1 to 5mm.

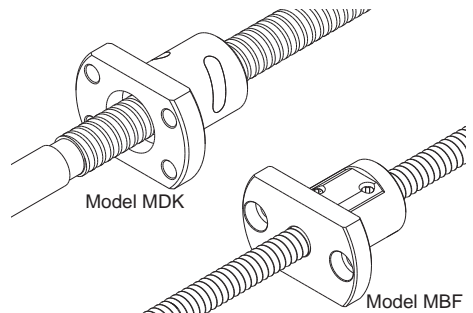



Model BNF

Specification Table⇒ **A15-124**

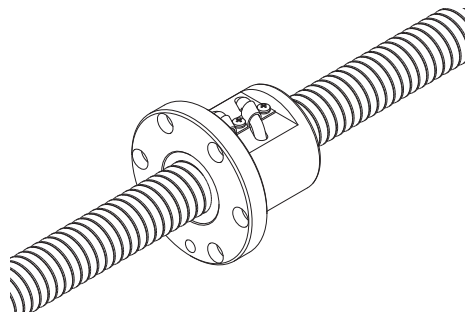
The simplest type with a single ball screw nut. It is designed to be mounted using the bolt holes drilled on the flange.



Nut Types and Axial Clearance

Screw shaft outer diameter (mm)	ϕ 4 to 14			
Nut type	Model MDK		Model MBF	
	 No preload type		 No preload type	
Accuracy grades	C3, C5	C7	C3, C5	C7
Axial clearance (mm)	0.005 or less (GT)	0.02 or less (G2)	0.005 or less (GT)	0.02 or less (G2)

Note) The symbols in the parentheses indicate axial clearance symbols.

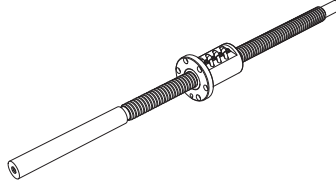
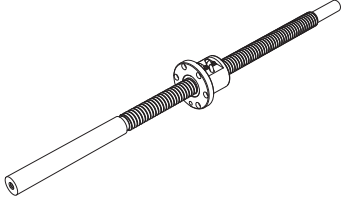
Screw shaft out diameter (mm)	ϕ 16 to 50			
Nut type	Model BIF		Model BNF	
	 Preload Type		 No preload type	
Accuracy grades	C5	C7	C5	C7
Axial clearance (mm)	0 or less (G0)	0 or less (G0)	0.01 or less (G1)	0.02 or less (G2)

Note1) The symbols in the parentheses indicate axial clearance symbols.

MDK (Unfinished Shaft Ends) No Preload

DN value	70000
----------	-------

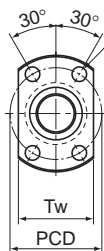
4- ϕ d₁ through hole

Model No.	Ball screw specifications							Nut			
	Screw shaft outer diameter	Lead	Ball center-to-center diameter	Thread minor diameter	No. of loaded circuits	Basic load rating		Outer diameter	Flange diameter	Overall length	Nut
						Ca	C _{0a}				
d	Ph	dp	dc	Rows X turns	kN	kN	D	D ₁	L ₁	H	
MDK 0401-3	4	1	4.15	3.4	3×1	0.29	0.42	9	19	13	3
MDK 0601-3	6	1	6.2	5.3	3×1	0.54	0.94	11	23	14.5	3.5
MDK 0801-3	8	1	8.2	7.3	3×1	0.64	1.4	13	26	15	4
MDK 0802-3	8	2	8.3	7	3×1	1.4	2.3	15	28	22	5
MDK 1002-3	10	2	10.3	9	3×1	1.5	2.9	17	34	22	5

Model number coding

MDK0401-3 GT +95L C5 A

Model No.

Overall screw shaft length (in mm)

Unfinished shaft ends code

Symbol for clearance in the axial direction (*1) Accuracy symbol (*2)

(*1) See **A15-19**. (*2) See **A15-12**.

Unfinished Shaft Ends Precision Ball Screw

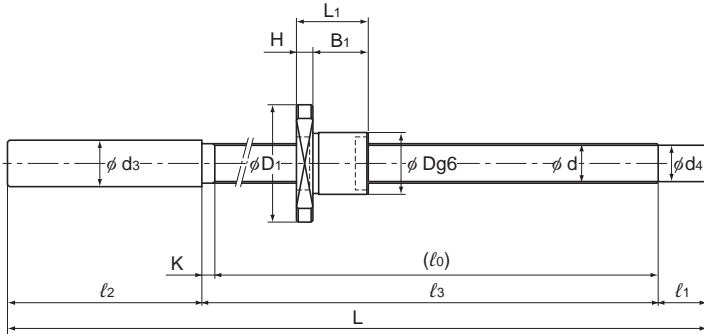

Unit: mm

Dimensions					Screw shaft dimensions									Nut mass	Shaft mass	
	B_1	PCD	d_i	T_w	Unfinished Shaft End Code	Overall length									kg	kg/m
	B_1	PCD	d_i	T_w		L	ℓ_0	ℓ_1	ℓ_2	ℓ_3	d_3	d_4	K			
	10	14	2.9	13	A	95	47	10	35	50	6.2	3.2	3	0.01	0.07	
					115	67	70									
					145	97	100									
	11	17	3.4	15	A	120	67	10	40	70	8.2	5.3	3	0.02	0.14	
					150	97	100									
					180	127	130									
	11	20	3.4	17	A	130	67	15	45	70	10.2	7.3	3	0.02	0.29	
					160	97	100									
					190	127	130									
					240	177	180									
	17	22	3.4	19	A	140	76	15	45	80	10.2	7	4	0.04	0.27	
					170	106	110									
					200	136	140									
					250	186	190									
	17	26	4.5	21	A	160	86	15	55	90	12.2	9	4	0.05	0.47	
					210	136	140									
					260	186	190									
					310	236	240									

Note) Models MDK 0401, 0601, and 0801 are not provided with a labyrinth seal.

MDK (Unfinished Shaft Ends) No Preload

DN value	70000
----------	-------

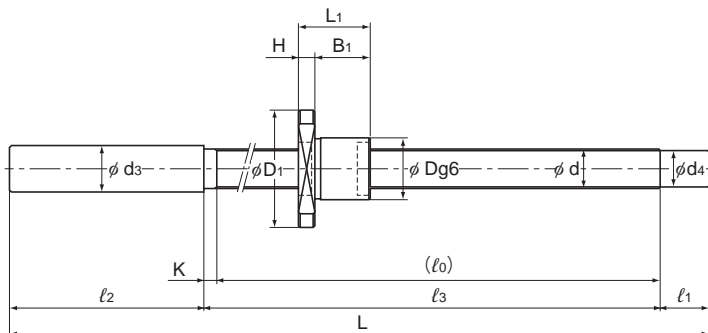
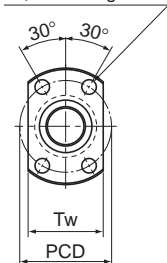
4- ϕ d1 through hole

Model No.	Ball screw specifications							Nut			
	Screw shaft outer diameter d	Lead Ph	Ball center-to-center diameter dp	Thread minor diameter dc	No. of loaded circuits Rows X turns	Basic load rating		Outer diameter D	Flange diameter D ₁	Overall length L ₁	Nut H
						Ca kN	C _{0a} kN				
MDK 1202-3	12	2	12.3	11	3×1	1.7	3.6	19	36	22	5
MDK 1402-3	14	2	14.3	13	3×1	1.8	4.3	21	40	23	6
MDK 1404-3	14	4	14.65	12.2	3×1	4.2	7.6	26	45	33	6
MDK 1405-3	14	5	14.75	11.2	3×1	7	11.6	26	45	42	10

Model number coding

MDK1202-3 RR GT +165L C5 A

Model No.	Seal symbol (*1)	Overall screw shaft length (in mm)	Unfinished shaft ends code
	Symbol for clearance in the axial direction (*2)	Accuracy symbol (*3)	

(*1) See **A15-336**. (*2) See **A15-19**. (*3) See **A15-12**.

Unfinished Shaft Ends Precision Ball Screw

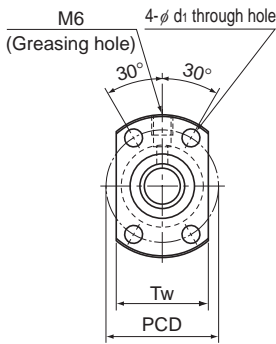

Unit: mm

Dimensions					Screw shaft dimensions										Nut mass kg	Shaft mass kg/m
B ₁	PCD	d ₁	Tw	Unfinished Shaft End Code	Overall length L	l ₀	l ₁	l ₂	l ₃	d ₃	d ₄	K				
17	28	4.5	23		A	165	86	15	60	90	14.2	11	4	0.05	0.71	
				215		136	140									
				265		186	190									
				315		236	240									
				365		286	290									
17	31	5.5	26	A	175	86	25	60	90	15.2	13	4	0.07	1		
					225	136			140							
					275	186			190							
					325	236			240							
					425	336			340							
27	36	5.5	28	A	240	150	25	60	155	15.2	11.9	5	0.14	0.8		
					290	200			205							
					340	250			255							
					440	350			355							
					540	450			455							
32	36	5.5	28	A	250	160	25	60	165	14	11.2	5	0.19	1.2		
					300	210			215							
					350	260			265							
					450	360			365							
					550	460			465							

Ball Screw

MBF (Unfinished Shaft Ends) No Preload

DN value	70000
----------	-------

2- ϕ d₁ through hole, ϕ d₂ counter bore depth h

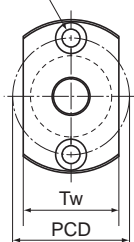

Model No.	Ball screw specifications							Nut			
	Screw shaft outer diameter d	Lead Ph	Ball center-to-center diameter dp	Thread minor diameter dc	No. of loaded circuits Rows X turns	Basic load rating		Outer diameter D	Flange diameter D _f	Overall length L _t	Nut H
						Ca kN	C _{0a} kN				
MBF 0401-3.7	4	1	4.15	3.3	1×3.7	0.59	0.93	11	24	18	4
MBF 0601-3.7	6	1	6.15	5.3	1×3.7	0.74	1.5	13	30	21	5
MBF 0802-3.7	8	2	8.3	6.6	1×3.7	2.5	4.2	20	40	28	6
MBF 1002-3.7	10	2	10.3	8.6	1×3.7	2.8	5.3	23	43	28	6
MBF 1202-3.7	12	2	12.3	10.6	1×3.7	3	6.5	25	47	30	8
MBF 1402-3.7	14	2	14.3	12.6	1×3.7	3.3	7.5	26	48	30	8
MBF 1404-3.7	14	4	14.3	11.8	1×3.7	5.7	11.1	30	54	38	8

Model number coding

MBF0802-3.7 RR GT +218L C5 A

Model No.

Seal symbol (*1)

Overall screw shaft length (in mm)

Unfinished shaft ends code

Symbol for clearance in the axial direction (*2)

Accuracy symbol (*3)

(*1) See **A15-336**. (*2) See **A15-19**. (*3) See **A15-12**.

Unfinished Shaft Ends Precision Ball Screw

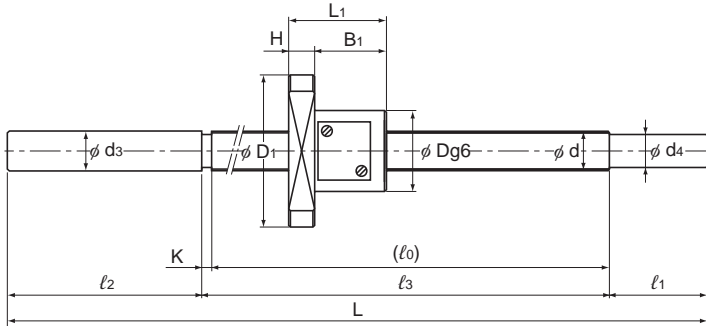

Unit: mm

Dimensions							Screw shaft dimensions										Nut mass kg	Shaft mass kg/m
B ₁	PCD	d ₁	d ₂	h	Tw	Unfinished Shaft End Code	Overall length L	l ₀	l ₁	l ₂	l ₃	d ₃	d ₄	K	kg	kg/m		
14	17	3.4	6.5	2.5	13	A	90	48	10	30	50	4.3	3.2	2	0.02	0.07		
							110	68			70							
							130	88			90							
16	21.5	3.4	6.5	3	17	A	131	58	20	50	61	6.3	5.2	3	0.04	0.14		
							161	88			91							
							201	128			131							
22	30	4.5	8	4	24	A	168	85	25	55	88	8.3	6.2	3	0.1	0.19		
							193	110			113							
							218	135			138							
22	33	4.5	8	4	27	A	183	95	25	60	98	10.3	8.2	3	0.11	0.36		
							223	135			138							
							273	185			188							
22	36	5.5	9.5	5.5	29	A	210	117	30	60	120	12.3	10.2	3	0.15	0.58		
							235	142			145							
							285	192			195							
22	37	5.5	9.5	5.5	32	A	205	102	40	60	105	14.3	12.2	3	0.16	0.85		
							245	142			145							
							295	192			195							
							345	242			245							
30	42	5.5	9.5	5.5	34	A	233	129	40	60	133	14.3	11.2	4	0.25	1.2		
							293	189			193							
							353	249			253							
							413	309			313							

Note) Models MBF 0401 and 0601 are not provided with a labyrinth seal.

BIF (Unfinished Shaft Ends) With Preload

DN value	70000
----------	-------

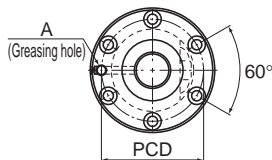

Model No.	Ball screw specifications							Nut			
	Screw shaft outer diameter d	Lead Ph	Ball center-to-center diameter dp	Thread minor diameter dc	No. of loaded circuits Rows X turns	Basic load rating		Outer diameter D	Flange diameter D _f	Overall length L ₁	Nut H
						Ca kN	C ₀ a kN				
BIF 1605-5	16	5	16.75	13.2	1×2.5	7.4	13.9	40	60	56	10
BIF 1810-3	18	10	18.8	15.5	1×1.5	5.1	9.6	42	65	75	12
BIF 2005-5	20	5	20.75	17.2	1×2.5	8.3	17.4	44	67	56	11
BIF 2505-5	25	5	25.75	22.2	1×2.5	9.2	22	50	73	55	11

Model number coding

BIF2005-5 RR G0 +610L C5 A

Model No.

Symbol for clearance
in the axial direction ^(*)2)

Accuracy symbol ^(*)3)

Unfinished shaft ends code (A or B)

Seal symbol ^(*)1)

Overall screw shaft
length (in mm)

(*1) See **A15-336**. (*2) See **A15-19**. (*3) See **A15-12**.

Unfinished Shaft Ends Precision Ball Screw

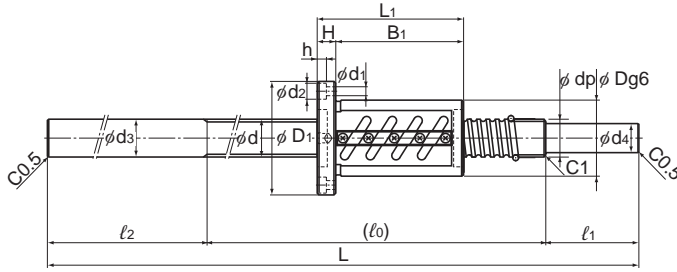

Unit: mm

Dimensions						Screw shaft dimensions								Nut mass kg	Shaft mass kg/m													
B ₁	PCD	d ₁	d ₂	h	Greasing hole A	Standard stock symbol	Overall length L	l ₀	l ₁	l ₂	d ₃	d ₄																
46	50	4.5	8	4.5	M6	A	410	200	50	160	16	12.8	0.56	0.92														
							510	300																				
							610	400																				
							710	500							1.25													
63	53	5.5	9.5	5.5	M6	A	410	200	50	160	18	15.3	0.75	1.62														
							510	300																				
							610	400																				
							710	500																				
45	55	5.5	9.5	5.5	M6	A	410	200	50	160	20	15.3	0.57	1.65														
							510	300																				
							610	400																				
							710	500																				
						810	600	16.8	0.57	1.65	B	610	300	50	260	20	16.8											
												710	400															
												44	61				5.5	9.5	5.5	M6	A	520	300	60	160	25	0.75	2.84
																						620	400					
720	500																											
820	600	20.3																										
1020	800																											
1220	1000	21.8																										
1420	1200	21.8	0.75	2.84	B	720	400	60	260	25	21.8																	
						820	500																					

Ball Screw

BIF (Unfinished Shaft Ends) With Preload

DN value	70000
----------	-------

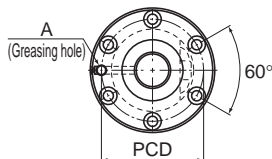

Model No.	Ball screw specifications							Nut			
	Screw shaft outer diameter d	Lead Ph	Ball center-to-center diameter dp	Thread minor diameter dc	No. of loaded circuits Rows X turns	Basic load rating		Outer diameter D	Flange diameter D _f	Overall length L _t	Nut H
						Ca kN	C _{0a} kN				
BIF 2510A-5	25	10	26.3	21.4	1×2.5	15.8	33	58	85	100	18
BIF 2806-5 BIF 2806-10	28	6	28.75	25.2	1×2.5 2×2.5	9.6 17.5	24.6 49.4	55	85	68 104	12
BIF 3205-5 BIF 3205-10	32	5	32.75	29.2	1×2.5 2×2.5	10.2 18.5	28.1 56.4	58	85	56 86	12

Model number coding

BIF2806-10 RR G0 +1020L C5 A

Model No.

Symbol for clearance
in the axial direction (*2)

Accuracy symbol (*3)

Unfinished shaft ends code (A or B)

Seal symbol (*1)

Overall screw shaft
length (in mm)

(*1) See **A15-336**. (*2) See **A15-19**. (*3) See **A15-12**.

Unfinished Shaft Ends Precision Ball Screw

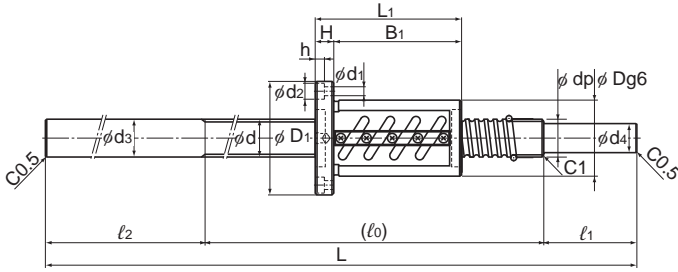

Unit: mm

Dimensions						Screw shaft dimensions								Nut mass kg	Shaft mass kg/m
B ₁	PCD	d ₁	d ₂	h	Greasing hole A	Standard stock symbol	Overall length L	l ₀	l ₁	l ₂	d ₃	d ₄			
82	71	6.6	11	6.5	M6	A	620	400	60	160	25	20.3	1.87	2.68	
							820	600							
							1020	800							
							1220	1000							
							1420	1200							
56 92	69	6.6	11	6.5	M6	A	520	300	60	160	28	20.3	1 1.57	3.89	
							620	400							
							720	500							
							920	700							
							1020	800							
							1220	1000							
						1420	1200								
						B	720	400	70	250	28	24.8			
							920	500							350
							1100	700							
44 74	71	6.6	11	6.5	M6	A	730	500	70	160	32	25.3	0.87 1.32	5.03	
							930	700							
							1230	1000							
							1430	1200							
							1630	1400							
							1830	1600				27.8			

Ball Screw

BIF (Unfinished Shaft Ends) With Preload

DN value	70000
----------	-------

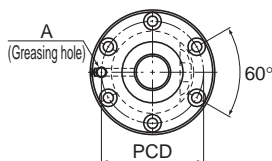

Model No.	Ball screw specifications							Nut			
	Screw shaft outer diameter d	Lead Ph	Ball center-to-center diameter dp	Thread minor diameter dc	No. of loaded circuits Rows X turns	Basic load rating		Outer diameter D	Flange diameter D _f	Overall length L ₁	Nut H
						Ca kN	C _{0a} kN				
BIF 3206-5 BIF 3206-10	32	6	33	28.4	1×2.5 2×2.5	13.9 25.2	35.2 70.4	62	89	63 99	12
BIF 3210A-5	32	10	33.75	26.4	1×2.5	26.1	56.2	74	108	100	15
BIF 3610-5 BIF 3610-10	36	10	37.75	30.5	1×2.5 2×2.5	27.6 50.1	63.3 126.4	75	120	111 171	18

Model number coding

BIF3206-10 RR G0 +1100L C5 B

Model No.

Symbol for clearance
in the axial direction ^{(*)2}

Accuracy symbol ^{(*)3}

Unfinished shaft ends code (A or B)

Seal symbol ^{(*)1}

Overall screw shaft
length (in mm)

(*)1 See **A15-336**. (*)2 See **A15-19**. (*)3 See **A15-12**.

Unfinished Shaft Ends Precision Ball Screw

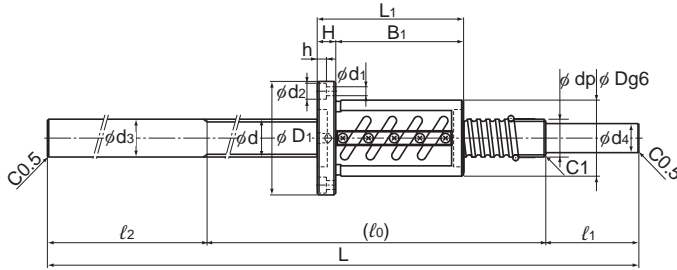

Unit: mm

Dimensions						Screw shaft dimensions							Nut mass kg	Shaft mass kg/m
B ₁	PCD	d ₁	d ₂	h	Greasing hole A	Standard stock symbol	Overall length L	l ₀	l ₁	l ₂	d ₃	d ₄		
51 87	75	6.6	11	6.5	M6	A	730	500	70	160	32	25.3	1.2 1.76	4.63
							930	700						
							1230	1000						
							1430	1200						
							1630	1400						
							1830	1600						
93 153	98	11	17.5	11	M6	A	730	500	70	160	36	30.3	3.4 4.8	5.03
							930	700						
							1430	1200						
93 153	98	11	17.5	11	M6	B	930	500	100	330	36	30.3	3.4 4.8	5.03
							1100	700		300				
							1830	1200		530				

BIF (Unfinished Shaft Ends) With Preload

DN value	70000
----------	-------

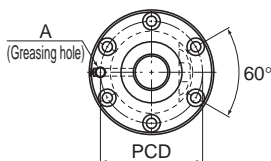

Model No.	Ball screw specifications							Nut			
	Screw shaft outer diameter d	Lead Ph	Ball center-to-center diameter dp	Thread minor diameter dc	No. of loaded circuits Rows X turns	Basic load rating		Outer diameter D	Flange diameter D _f	Overall length L ₁	Nut H
						Ca kN	C _{0a} kN				
BIF 4010-5 BIF 4010-10	40	10	41.75	34.4	1×2.5 2×2.5	29 52.7	70.4 141.1	82	124	103 163	18
BIF 4012-5 BIF 4012-10	40	12	42	34.1	1×2.5 2×2.5	33.9 61.6	79.2 158.8	84	126	119 191	18
BIF 5010-5 BIF 5010-10	50	10	51.75	44.4	1×2.5 2×2.5	32 58.2	88.2 176.4	93	135	103 163	18

Model number coding

BIF4012-10 RR G0 +1230L C5 A

Model No.

Symbol for clearance
in the axial direction (*2)

Accuracy symbol (*3)

Unfinished shaft ends code (A or B)

Seal symbol (*1) Overall screw shaft
length (in mm)

(*1) See **A15-336**. (*2) See **A15-19**. (*3) See **A15-12**.

Unfinished Shaft Ends Precision Ball Screw

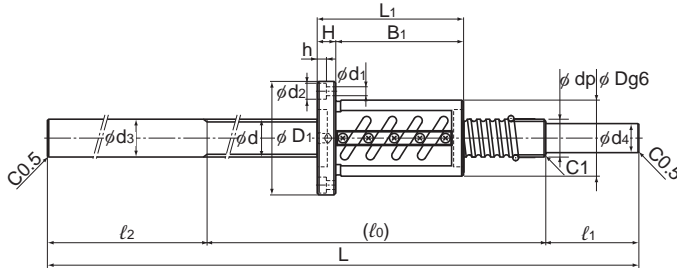

Unit: mm

Dimensions							Screw shaft dimensions							Nut mass kg	Shaft mass kg/m
B ₁	PCD	d ₁	d ₂	h	Greasing hole A	Standard stock symbol	Overall length L	l ₀	l ₁	l ₂	d ₃	d ₄			
85 145	102	11	17.5	11	M6	A	1230	1000	70	160	40	30.3	3.58 5.18	6.59	
							1730	1500							
							2030	1800							
							2230	2000							
101 173	104	11	17.5	11	M6	A	1230	1000	70	160	40	30.3	4.2 6.24	6.39	
							1730	1500							
							2030	1800							
							2230	2000							
						B	1730	1200	100	430	40	33.8			
							2030	1200		730					
85 145	113	11	17.5	11	R1/8 (PT1/8)	A	1300	1000	100	200	50	40.3	4.4 6.35	11.36	
							1800	1500							
							2300	2000							
							2800	2500							

Ball Screw

BNF (Unfinished Shaft Ends) No Preload

DN value	70000
----------	-------

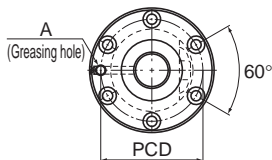

Model No.	Ball screw specifications							Nut			
	Screw shaft outer diameter d	Lead Ph	Ball center-to-center diameter dp	Thread minor diameter dc	No. of loaded circuits Rows X turns	Basic load rating		Outer diameter D	Flange diameter D _f	Overall length L ₁	Nut H
						Ca kN	C _{0a} kN				
BNF 1605-2.5	16	5	16.75	13.2	1×2.5	7.4	13.9	40	60	41	10
BNF 1810-2.5	18	10	18.8	15.5	1×2.5	7.8	15.9	42	65	69	12
BNF 2005-5	20	5	20.75	17.2	2×2.5	15.1	35	44	67	56	11
BNF 2505-5	25	5	25.75	22.2	2×2.5	16.7	44	50	73	55	11

Model number coding

BNF2005-5 RR G0 +610L C5 A

Model No.

Symbol for clearance
in the axial direction (*2)

Accuracy symbol (*3)

Unfinished shaft ends code (A or B)

Seal symbol (*1)

Overall screw shaft
length (in mm)

(*1) See [A15-336](#). (*2) See [A15-19](#). (*3) See [A15-12](#).

Unfinished Shaft Ends Precision Ball Screw

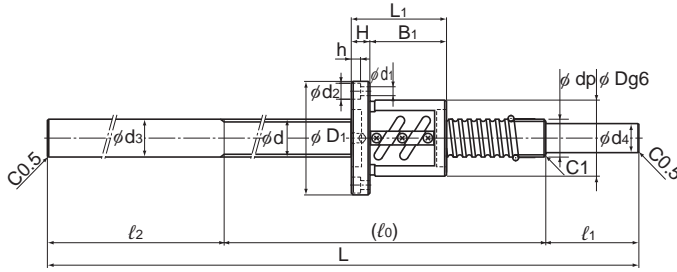

Unit: mm

Dimensions						Screw shaft dimensions								Nut mass kg	Shaft mass kg/m				
B ₁	PCD	d ₁	d ₂	h	Greasing hole A	Standard stock symbol	Overall length L	l ₀	l ₁	l ₂	d ₃	d ₄	kg			kg/m			
31	50	4.5	8	4.5	M6	A	410	200	50	160	16	12.8	0.37	0.92					
							510	300											
							610	400											
							710	500							1.25				
57	53	5.5	9.5	5.5	M6	A	410	200	50	160	18	15.3	0.67	1.62					
							510	300											
							610	400											
							710	500											
45	55	5.5	9.5	5.5	M6	A	410	200	50	160	20	15.3	0.57	1.65					
							510	300											
							610	400											
							710	500											
						810	600	16.8	0.57	1.65	B	610	300	50	260	20	16.8	0.57	1.65
												710	400						
												810	500						
												1010	800						
44	61	5.5	9.5	5.5	M6	A	520	300	60	160	25	20.3	0.75	2.84					
							620	400											
							720	500											
							820	600											
						1020	800	21.8	0.75	2.84	B	1220	1000	60	260	25	21.8	0.75	2.84
												1420	1200						
												720	400						
												820	500						

Ball Screw

BNF (Unfinished Shaft Ends) No Preload

DN value	70000
----------	-------

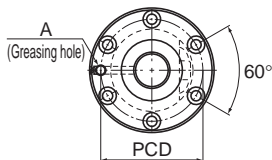

Model No.	Ball screw specifications							Nut			
	Screw shaft outer diameter d	Lead Ph	Ball center-to-center diameter dp	Thread minor diameter dc	No. of loaded circuits Rows X turns	Basic load rating		Outer diameter D	Flange diameter D _f	Overall length L ₁	Nut H
						Ca kN	C _{0a} kN				
BNF 2510A-2.5	25	10	26.3	21.4	1×2.5	15.8	33	58	85	70	18
BNF 2806-5	28	6	28.75	25.2	2×2.5	17.5	49.4	55	85	68	12
BNF 3205-5	32	5	32.75	29.2	2×2.5	18.5	56.4	58	85	56	12

Model number coding

BNF2806-10 RR G0 +1020L C5 A

Model No.

Symbol for clearance in the axial direction (*2)

Accuracy symbol (*3)

Unfinished shaft ends code (A or B)

Seal symbol (*1)

Overall screw shaft length (in mm)

(*1) See [A15-336](#). (*2) See [A15-19](#). (*3) See [A15-12](#).

Unfinished Shaft Ends Precision Ball Screw

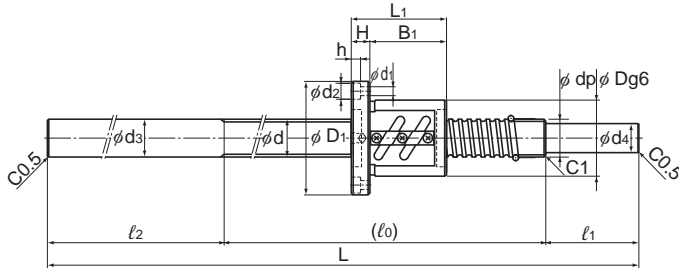

Unit: mm

Dimensions						Screw shaft dimensions							Nut mass kg	Shaft mass kg/m
B ₁	PCD	d ₁	d ₂	h	Greasing hole A	Standard stock symbol	Overall length L	l ₀	l ₁	l ₂	d ₃	d ₄		
52	71	6.6	11	6.5	M6	A	620	400	60	160	25	20.3	1.43	2.68
							820	600						
							1020	800						
							1220	1000						
							1420	1200						
56	69	6.6	11	6.5	M6	A	520	300	60	160	28	20.3	1.13	3.89
							620	400						
							720	500						
							920	700				24.8		
							1020	800						
							1220	1000						
						B	720	400	70	250	28	24.8		
							920	500		350				
							1100	700		330				
						44	71	6.6	11	6.5	M6	A	730	500
930	700													
1230	1000													
1430	1200	27.8												
1630	1400													
1830	1600													

Ball Screw

BNF (Unfinished Shaft Ends) No Preload

DN value	70000
----------	-------

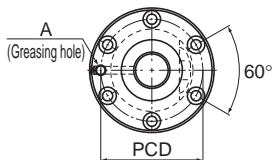

Model No.	Ball screw specifications							Nut			
	Screw shaft outer diameter d	Lead Ph	Ball center-to-center diameter dp	Thread minor diameter dc	No. of loaded circuits Rows X turns	Basic load rating		Outer diameter D	Flange diameter D _f	Overall length L ₁	Nut H
						Ca kN	C _{0a} kN				
BNF 3206-5	32	6	33	28.4	2×2.5	25.2	70.4	62	89	63	12
BNF 3210A-5	32	10	33.75	26.4	2×2.5	47.2	112.7	74	108	100	15
BNF 3610-5	36	10	37.75	30.5	2×2.5	50.1	126.4	75	120	111	18

Model number coding

BNF3206-10 RR G0 +1100L C5 B

Model No.

Symbol for clearance
in the axial direction ^{(*)2}

Accuracy symbol ^{(*)3}

Unfinished shaft ends code (A or B)

Seal symbol ^{(*)1}

Overall screw shaft
length (in mm)

(*)1 See **A15-336**. (*)2 See **A15-19**. (*)3 See **A15-12**.

BNF (Unfinished Shaft Ends) No Preload

DN value	70000
----------	-------

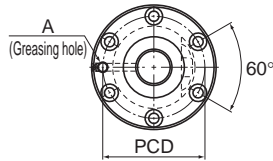

Model No.	Ball screw specifications							Nut			
	Screw shaft outer diameter d	Lead Ph	Ball center-to-center diameter dp	Thread minor diameter dc	No. of loaded circuits Rows X turns	Basic load rating		Outer diameter D	Flange diameter D _f	Overall length L _t	Nut H
						Ca kN	C _{0a} kN				
BNF 4010-5	40	10	41.75	34.4	2×2.5	52.7	141.1	82	124	103	18
BNF 4012-5	40	12	42	34.1	2×2.5	61.6	158.8	84	126	119	18
BNF 5010-5	50	10	51.75	44.4	2×2.5	58.2	176.4	93	135	103	18

Model number coding

BNF4012-10 RR G0 +1230L C5 A

Model No.

Symbol for clearance in the axial direction (*2)

Accuracy symbol (*3)

Unfinished shaft ends code (A or B)

Seal symbol (*1)

Overall screw shaft length (in mm)

(*1) See [A15-336](#). (*2) See [A15-19](#). (*3) See [A15-12](#).

Unfinished Shaft Ends Precision Ball Screw

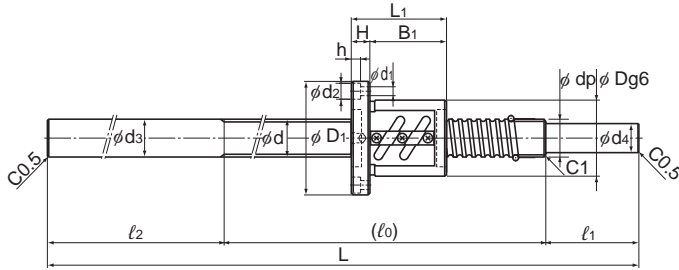

Unit: mm

Dimensions						Screw shaft dimensions								Nut mass kg	Shaft mass kg/m
B ₁	PCD	d ₁	d ₂	h	Greasing hole A	Standard stock symbol	Overall length L	l ₀	l ₁	l ₂	d ₃	d ₄			
85	102	11	17.5	11	M6	A	1230	1000	70	160	40	30.3	3.58	6.59	
							1730	1500							
							2030	1800							
							2230	2000							
101	104	11	17.5	11	M6	A	1230	1000	70	160	40	30.3	4.2	6.39	
							1730	1500							
							2030	1800							
							2230	2000							
						B	1730	1200	100	430	40	33.8			
							2030	1200		730					
85	113	11	17.5	11	R1/8 (PT1/8)	A	1300	1000	100	200	50	40.3	4.4	11.36	
							1800	1500							
							2300	2000							
							2800	2500							

Ball Screw

Finished Shaft Ends Precision Ball Screw

Model BNK

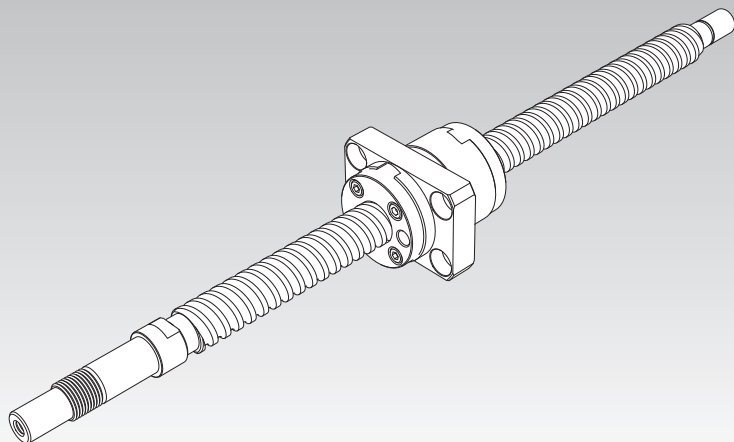

Point of Selection **A15-8**

Options **A15-336**

Model No. **A15-353**

Precautions on Use **A15-358**

Accessories for Lubrication **A24-1**

Mounting Procedure and Maintenance **B15-104**

Lead Angle Accuracy **A15-11**

Accuracy of the Mounting Surface **A15-14**

DN Value **A15-33**

Support Unit **A15-300**

Nut Bracket **A15-330**

Dimensions of Each Model with an Option Attached **A15-344**

Features

To meet the space-saving requirement, this type of Ball Screw has a standardized screw shaft and a ball screw nut. The ends of the screw shaft are standardized to fit the corresponding support unit. The shaft support method with models BNK0401, 0501 and 0601 is “fixed-free,” while other models use the “fixed-supported” method with the shaft directly coupled with the motor.

Screw shafts and nuts are compactly designed. When a support unit and a nut bracket are combined with a Ball Screw, the assembly can be mounted on your machine as it is. Thus, a high-accuracy feed mechanism can easily be achieved.

[Contamination Protection and Lubrication]

Each ball screw nut contains a right amount of grease. In addition, the ball nuts of model BNK0802 or higher contain a labyrinth seal (with models BNK1510, BNK1520, BNK1616, BNK2020 and BNK2520, the end cap also serves as a labyrinth seal).

When foreign material may enter the screw nut, it is necessary to use a dust-prevention device (e.g., bellows) to completely protect the screw shaft.

Types and Features

Model BNK

For this model, screw shafts with a diameter $\phi 4$ to $\phi 25$ mm and a lead 1 to 20 mm are available as the standard.

Specification Table ⇒ **A15-136**

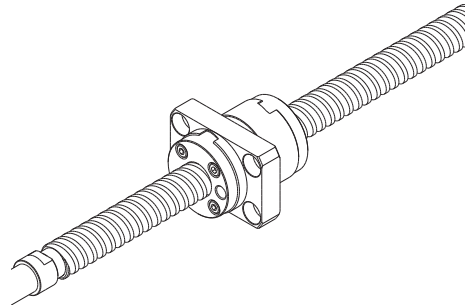

Table of Ball Screw Types with Finished Shaft Ends and the Corresponding Support Units and Nut Brackets

Model No.		BNK																						
		0401		0501		0601		0801		0802		0810		1002		1004		1010						
Accuracy grades		C3, C5, C7		C3, C5, C7		C3, C5, C7		C3, C5, C7		C3, C5, C7		C5, C7		C3, C5, C7		C3, C5, C7		C5, C7						
Axial clearance ^{Note}		G0	GT	G2	G0	GT	G2	G0	GT	G2	G0	GT	G2	—	GT	G2	G0	GT	G2	G0	GT	G2		
Stroke (mm)	20	●			●																			
	30																							
	40	●			●			●		●														
	50																●		●					
	60																							
	70	●			●			●		●														
	100							●		●				●		●		●		●				●
	120																							
	150									●				●		●		●		●				●
	170																							
	200													●		●		●		●				●
	250													●		●		●		●				●
	300													●		●		●		●				●
	350																							
	400																							
	450																							
	500																							
	550																							
	600																							
	700																							
800																								
900																								
1000																								
1100																								
1200																								
1400																								
1600																								
Support unit: square on fixed side		EK4		EK4		EK5		EK6		EK6		EK6		EK8		EK10		EK10						
		—		—		—		—		—		—		—		—		BK10		BK10				
Support unit: round on fixed side		FK4		FK4		FK5		FK6		FK6		FK6		FK8		FK10		FK10						
Support unit: square on supported side		—		—		—		EF6		EF6		EF6		EF8		EF10		EF10						
Support unit: round on supported side		—		—		—		FF6		FF6		FF6		FF6		FF10		FF10						
Nut bracket		—		—		—		—		—		—		—		—		MC1004		MC1004				

Note) Axial clearance: G0: 0 or less

GT: 0.005 mm or less

G2: 0.02 mm or less

For details of the support unit and the nut bracket, see **A15-300** onward and **A15-330** onward, respectively.

BNK0401-3 Shaft diameter: 4; lead: 1

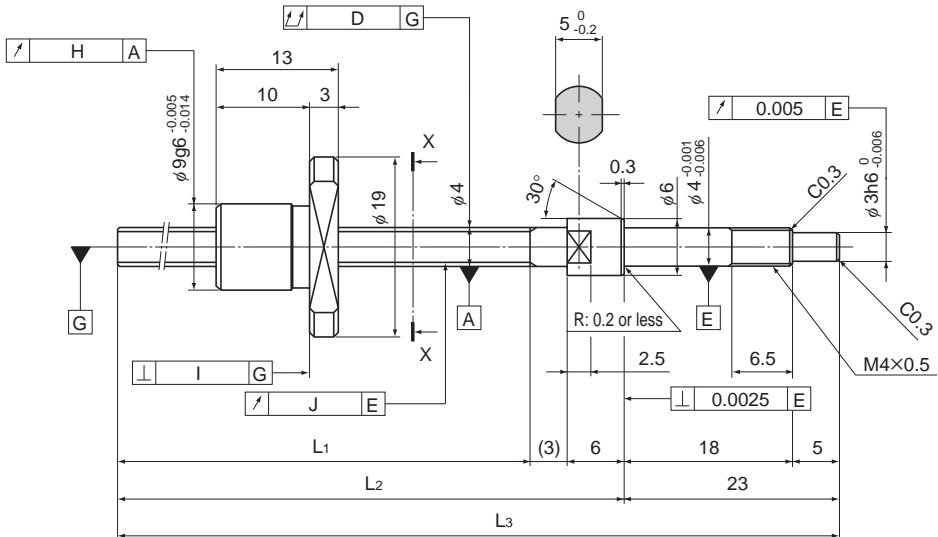

Model No.	Stroke	Screw shaft length		
		L ₁	L ₂	L ₃
BNK 0401-3G0+77LC3Y	20	45	54	77
BNK 0401-3G0+77LC5Y				
BNK 0401-3G2+77LC7Y				
BNK 0401-3G0+97LC3Y	40	65	74	97
BNK 0401-3G0+97LC5Y				
BNK 0401-3G2+97LC7Y				
BNK 0401-3G0+127LC3Y	70	95	104	127
BNK 0401-3G0+127LC5Y				
BNK 0401-3G2+127LC7Y				

Note) A stainless steel type is also available for model BNK0401. When placing an order, add symbol "M" to the end of the model number.

(Example) BNK0401-3G0+77LC3Y M

Symbol for stainless steel type

For accuracy grades C3 and C5, clearance GT is also available as standard.

Finished Shaft Ends Precision Ball Screw

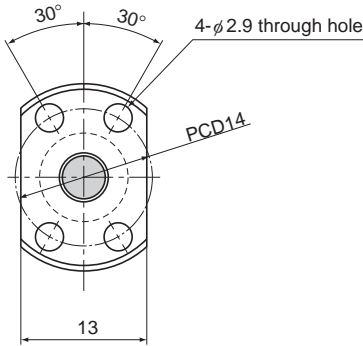

X-X arrow view

Ball Screw Specifications			
Lead (mm)	1		
BCD (mm)	4.15		
Thread minor diameter (mm)	3.4		
Threading direction, No. of threaded grooves	Rightward, 1		
No. of circuits	1 turn × 3 rows		
Clearance symbol	G0	GT	G2
Axial clearance (mm)	0	0.005 or less	0.02 or less
Basic dynamic load rating C_a (kN)	0.29	0.29	0.29
Basic static load rating C_{0a} (kN)	0.42	0.42	0.42
Preload torque (N-m)	to 9.8×10^{-3}	—	—
Spacer ball	None	None	None
Rigidity value (N/ μ m)	35		
Circulation method	Deflector		

Unit: mm

	Runout of the screw shaft axis D	Runout of the nut circumference H	Flange perpendicularity I	Runout of the thread groove surface J	Lead angle accuracy		Nut mass kg	Shaft mass kg/m
					Representative travel distance error	Fluctuation		
	0.015	0.009	0.008	0.008	± 0.008	0.008	0.01	0.07
	0.025	0.012	0.01	0.01	± 0.018	0.018	0.01	0.07
	0.035	0.02	0.014	0.014	Travel distance: $\pm 0.05/300$		0.01	0.07
	0.02	0.009	0.008	0.008	± 0.008	0.008	0.01	0.07
	0.025	0.012	0.01	0.01	± 0.018	0.018	0.01	0.07
	0.035	0.02	0.014	0.014	Travel distance: $\pm 0.05/300$		0.01	0.07
	0.025	0.009	0.008	0.008	± 0.008	0.008	0.01	0.07
	0.035	0.012	0.01	0.01	± 0.018	0.018	0.01	0.07
	0.05	0.02	0.014	0.014	Travel distance: $\pm 0.05/300$		0.01	0.07

BNK0501-3 Shaft diameter: 5; lead: 1

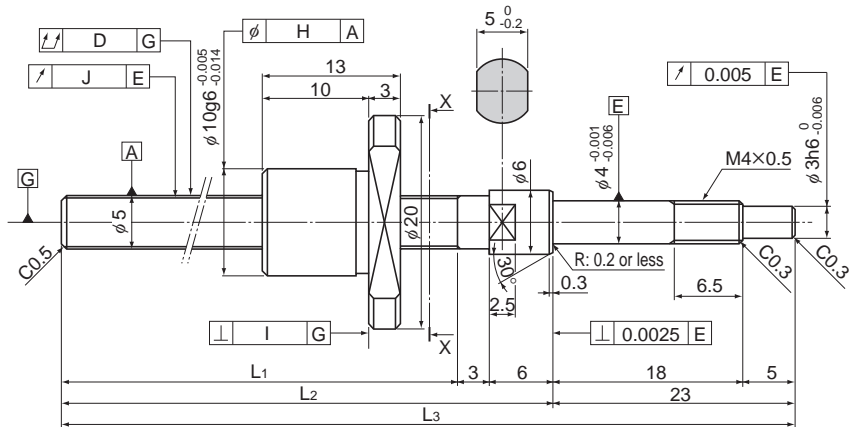

Model No.	Stroke	Screw shaft length		
		L ₁	L ₂	L ₃
BNK 0501-3G0+77LC3Y	20	45	54	77
BNK 0501-3G0+77LC5Y				
BNK 0501-3G2+77LC7Y				
BNK 0501-3G0+97LC3Y	40	65	74	97
BNK 0501-3G0+97LC5Y				
BNK 0501-3G2+97LC7Y				
BNK 0501-3G0+127LC3Y	70	95	104	127
BNK 0501-3G0+127LC5Y				
BNK 0501-3G2+127LC7Y				

Note) A stainless steel type is also available for model BNK0501. When placing an order, add symbol "M" to the end of the model number.

(Example) BNK0501-3G0+77LC3Y M

Symbol for stainless steel type

For accuracy grades C3 and C5, clearance GT is also available as standard.

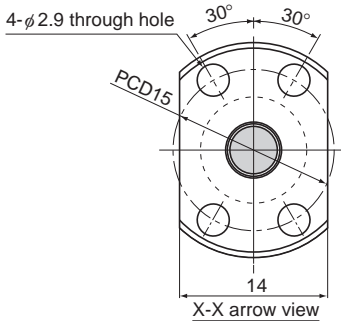

Ball Screw Specifications			
Lead (mm)	1		
BCD (mm)	5.15		
Thread minor diameter (mm)	4.4		
Threading direction, No. of threaded grooves	Rightward, 1		
No. of circuits	1 turn × 3 rows		
Clearance symbol	G0	GT	G2
Axial clearance (mm)	0	0.005 or less	0.02 or less
Basic dynamic load rating C_a (kN)	0.32	0.32	0.32
Basic static load rating C_{0a} (kN)	0.55	0.55	0.55
Preload torque (N-m)	to 9.8×10^{-3}	—	—
Spacer ball	None	None	None
Rigidity value (N/ μ m)	47		
Circulation method	Deflector		

Unit: mm

	Runout of the screw shaft axis D	Runout of the nut circumference H	Flange perpendicularity I	Runout of the thread groove surface J	Lead angle accuracy		Nut mass kg	Shaft mass kg/m
					Representative travel distance error	Fluctuation		
	0.015	0.009	0.008	0.008	± 0.008	0.008	0.012	0.11
	0.025	0.012	0.01	0.01	± 0.018	0.018	0.012	0.11
	0.035	0.02	0.014	0.014	Travel distance: $\pm 0.05/300$		0.012	0.11
	0.02	0.009	0.008	0.008	± 0.008	0.008	0.012	0.11
	0.025	0.012	0.01	0.01	± 0.018	0.018	0.012	0.11
	0.035	0.02	0.014	0.014	Travel distance: $\pm 0.05/300$		0.012	0.11
	0.025	0.009	0.008	0.008	± 0.008	0.008	0.012	0.11
	0.035	0.012	0.01	0.01	± 0.018	0.018	0.012	0.11
	0.05	0.02	0.014	0.014	Travel distance: $\pm 0.05/300$		0.012	0.11

BNK0601-3 Shaft diameter: 6; lead: 1

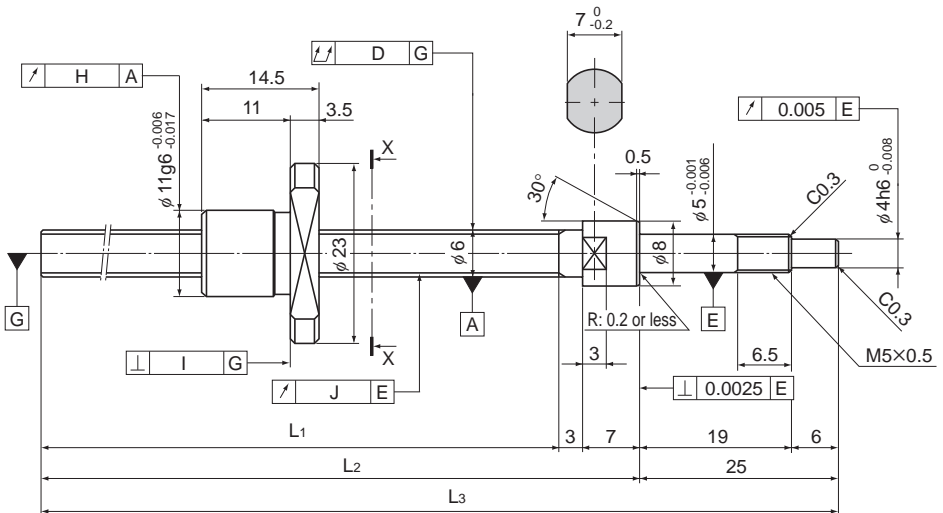

Model No.	Stroke	Screw shaft length		
		L ₁	L ₂	L ₃
BNK 0601-3G0+100LC3Y	40	65	75	100
BNK 0601-3G0+100LC5Y				
BNK 0601-3G2+100LC7Y				
BNK 0601-3G0+130LC3Y	70	95	105	130
BNK 0601-3G0+130LC5Y				
BNK 0601-3G2+130LC7Y				
BNK 0601-3G0+160LC3Y	100	125	135	160
BNK 0601-3G0+160LC5Y				
BNK 0601-3G2+160LC7Y				

Note) A stainless steel type is also available for model BNK0601. When placing an order, add symbol "M" to the end of the model number.

(Example) BNK0601-3G0+100LC3Y M

Symbol for stainless steel type

For accuracy grades C3 and C5, clearance GT is also available as standard.

Finished Shaft Ends Precision Ball Screw

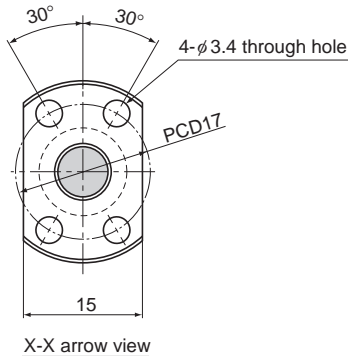

Ball Screw Specifications			
Lead (mm)	1		
BCD (mm)	6.2		
Thread minor diameter (mm)	5.3		
Threading direction, No. of threaded grooves	Rightward, 1		
No. of circuits	1 turn × 3 rows		
Clearance symbol	G0	GT	G2
Axial clearance (mm)	0	0.005 or less	0.02 or less
Basic dynamic load rating C_a (kN)	0.54	0.54	0.54
Basic static load rating C_{0a} (kN)	0.94	0.94	0.94
Preload torque (N-m)	to 1.3×10^2	—	—
Spacer ball	None	None	None
Rigidity value (N/ μ m)	60		
Circulation method	Deflector		

Unit: mm

	Runout of the screw shaft axis D	Runout of the nut circumference H	Flange perpendicularity I	Runout of the thread groove surface J	Lead angle accuracy		Nut mass kg	Shaft mass kg/m
					Representative travel distance error	Fluctuation		
	0.015	0.009	0.008	0.008	± 0.008	0.008	0.017	0.14
	0.025	0.012	0.01	0.01	± 0.018	0.018	0.017	0.14
	0.035	0.02	0.014	0.014	Travel distance: $\pm 0.05/300$		0.017	0.14
	0.02	0.009	0.008	0.008	± 0.008	0.008	0.017	0.14
	0.035	0.012	0.01	0.01	± 0.018	0.018	0.017	0.14
	0.05	0.02	0.014	0.014	Travel distance: $\pm 0.05/300$		0.017	0.14
	0.025	0.009	0.008	0.008	± 0.01	0.008	0.017	0.14
	0.035	0.012	0.01	0.01	± 0.02	0.018	0.017	0.14
	0.05	0.02	0.014	0.014	Travel distance: $\pm 0.05/300$		0.017	0.14

BNK0801-3 Shaft diameter: 8; lead: 1

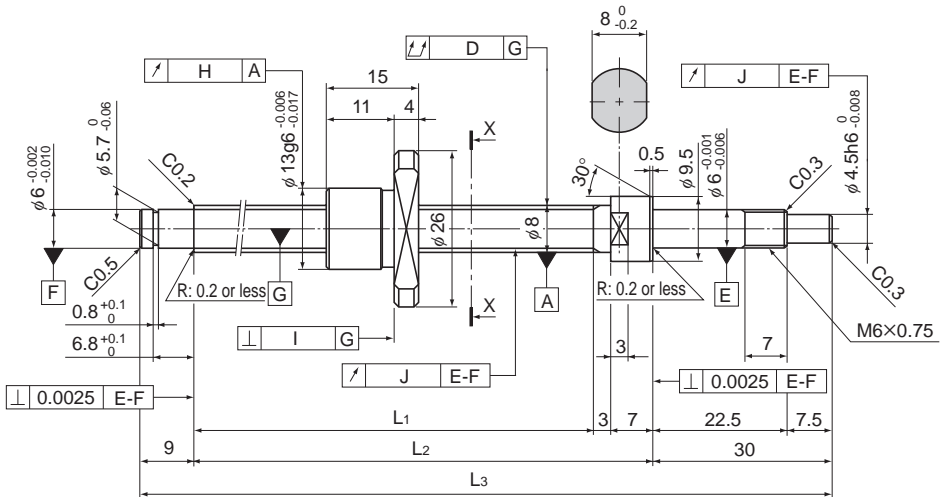

Model No.	Stroke	Screw shaft length		
		L ₁	L ₂	L ₃
BNK 0801-3G0+115LC3Y	40	66	76	115
BNK 0801-3G0+115LC5Y				
BNK 0801-3G2+115LC7Y				
BNK 0801-3G0+145LC3Y	70	96	106	145
BNK 0801-3G0+145LC5Y				
BNK 0801-3G2+145LC7Y				
BNK 0801-3G0+175LC3Y	100	126	136	175
BNK 0801-3G0+175LC5Y				
BNK 0801-3G2+175LC7Y				
BNK 0801-3G0+225LC3Y	150	176	186	225
BNK 0801-3G0+225LC5Y				
BNK 0801-3G2+225LC7Y				

Note) A stainless steel type is also available for model BNK0801. When placing an order, add symbol "M" to the end of the model number.

(Example) BNK0801-3G0+115LC3Y M

Symbol for stainless steel type

For accuracy grades C3 and C5, clearance GT is also available as standard.

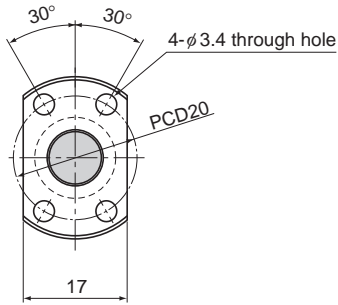

X-X arrow view

Ball Screw Specifications			
Lead (mm)	1		
BCD (mm)	8.2		
Thread minor diameter (mm)	7.3		
Threading direction, No. of threaded grooves	Rightward, 1		
No. of circuits	1 turn × 3 rows		
Clearance symbol	G0	GT	G2
Axial clearance (mm)	0	0.005 or less	0.02 or less
Basic dynamic load rating C_a (kN)	0.64	0.64	0.64
Basic static load rating C_{0a} (kN)	1.4	1.4	1.4
Preload torque (N-m)	to 1.8×10^2	—	—
Spacer ball	None	None	None
Rigidity value (N/ μ m)	80		
Circulation method	Deflector		

Unit: mm

	Runout of the screw shaft axis D	Runout of the nut circumference H	Flange perpendicularity I	Runout of the thread groove surface J	Lead angle accuracy		Nut mass kg	Shaft mass kg/m
					Representative travel distance error	Fluctuation		
	0.025	0.009	0.008	0.008	± 0.008	0.008	0.024	0.29
	0.025	0.012	0.01	0.01	± 0.018	0.018	0.024	0.29
	0.035	0.02	0.014	0.014	Travel distance: $\pm 0.05/300$		0.024	0.29
	0.03	0.009	0.008	0.008	± 0.008	0.008	0.024	0.29
	0.035	0.012	0.01	0.01	± 0.018	0.018	0.024	0.29
	0.05	0.02	0.014	0.014	Travel distance: $\pm 0.05/300$		0.024	0.29
	0.03	0.009	0.008	0.008	± 0.01	0.008	0.024	0.29
	0.035	0.012	0.01	0.01	± 0.02	0.018	0.024	0.29
	0.05	0.02	0.014	0.014	Travel distance: $\pm 0.05/300$		0.024	0.29
	0.035	0.009	0.008	0.008	± 0.01	0.008	0.024	0.29
	0.05	0.012	0.01	0.01	± 0.02	0.018	0.024	0.29
	0.065	0.02	0.014	0.014	Travel distance: $\pm 0.05/300$		0.024	0.29

Finished Shaft Ends Precision Ball Screw

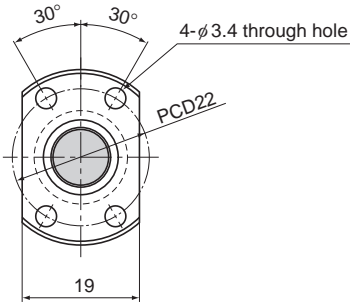

X-X arrow view

Ball Screw Specifications			
Lead (mm)	2		
BCD (mm)	8.3		
Thread minor diameter (mm)	7		
Threading direction, No. of threaded grooves	Rightward, 1		
No. of circuits	1 turn × 3 rows		
Clearance symbol	G0	GT	G2
Axial clearance (mm)	0	0.005 or less	0.02 or less
Basic dynamic load rating C_a (kN)	1.4	1.4	1.4
Basic static load rating C_{0a} (kN)	2.3	2.3	2.3
Preload torque (N-m)	to 2×10^{-2}	—	—
Spacer ball	None	None	None
Rigidity value (N/ μ m)	100		
Circulation method	Deflector		

Unit: mm

	Runout of the screw shaft axis	Runout of the nut circumference	Flange perpendicularity	Runout of the thread groove surface	Lead angle accuracy		Nut mass kg	Shaft mass kg/m
	D	H	I	J	Representative travel distance error	Fluctuation		
	0.025	0.009	0.008	0.008	± 0.008	0.008	0.034	0.27
	0.025	0.012	0.01	0.01	± 0.018	0.018	0.034	0.27
	0.035	0.02	0.014	0.014	Travel distance: $\pm 0.05/300$		0.034	0.27
	0.03	0.009	0.008	0.008	± 0.01	0.008	0.034	0.27
	0.035	0.012	0.01	0.01	± 0.02	0.018	0.034	0.27
	0.05	0.02	0.014	0.014	Travel distance: $\pm 0.05/300$		0.034	0.27
	0.03	0.009	0.008	0.008	± 0.01	0.008	0.034	0.27
	0.035	0.012	0.01	0.01	± 0.02	0.018	0.034	0.27
	0.05	0.02	0.014	0.014	Travel distance: $\pm 0.05/300$		0.034	0.27
	0.035	0.009	0.008	0.008	± 0.01	0.008	0.034	0.27
	0.05	0.012	0.01	0.01	± 0.02	0.018	0.034	0.27
	0.065	0.02	0.014	0.014	Travel distance: $\pm 0.05/300$		0.034	0.27

BNK0810-3 Shaft diameter: 8; lead: 10

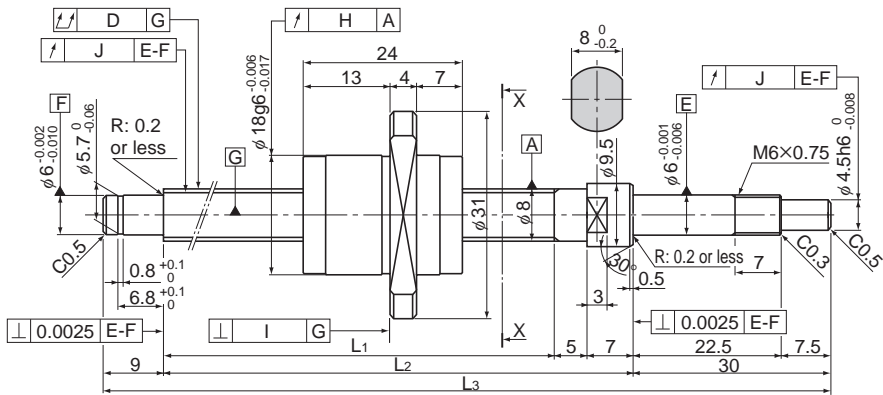

Model No.	Stroke	Screw shaft length		
		L ₁	L ₂	L ₃
BNK 0810-3GT+205LC5Y	100	154	166	205
BNK 0810-3G2+205LC7Y				
BNK 0810-3GT+255LC5Y	150	204	216	255
BNK 0810-3G2+255LC7Y				
BNK 0810-3GT+305LC5Y	200	254	266	305
BNK 0810-3G2+305LC7Y				
BNK 0810-3GT+355LC5Y	250	304	316	355
BNK 0810-3G2+355LC7Y				
BNK 0810-3GT+405LC5Y	300	354	366	405
BNK 0810-3G2+405LC7Y				

Finished Shaft Ends Precision Ball Screw

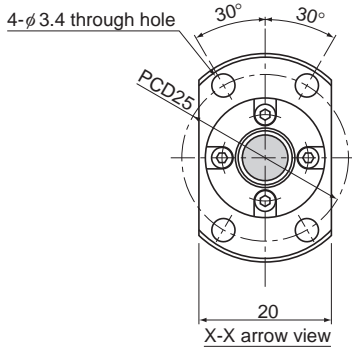

Ball Screw Specifications		
Lead (mm)	10	
BCD (mm)	8.4	
Thread minor diameter (mm)	6.7	
Threading direction, No. of threaded grooves	Rightward, 2	
No. of circuits	1.5 turns \times 2 rows	
Clearance symbol	GT	G2
Axial clearance (mm)	0.005 or less	0.02 or less
Basic dynamic load rating C_a (kN)	2.16	2.16
Basic static load rating C_{0a} (kN)	3.82	3.82
Preload torque (N-m)	—	—
Spacer ball	None	None
Rigidity value (N/ μ m)	100	
Circulation method	End cap	

Unit: mm

	Runout of the screw shaft axis D	Runout of the nut circumference H	Flange perpendicularity I	Runout of the thread groove surface J	Lead angle accuracy		Nut mass kg	Shaft mass kg/m
					Representative travel distance error	Fluctuation		
	0.05	0.012	0.01	0.01	± 0.02	0.018	0.049	0.30
	0.065	0.02	0.014	0.014	Travel distance: $\pm 0.05/300$		0.049	0.30
	0.05	0.012	0.01	0.01	± 0.023	0.018	0.049	0.30
	0.065	0.02	0.014	0.014	Travel distance: $\pm 0.05/300$		0.049	0.30
	0.05	0.012	0.01	0.01	± 0.023	0.018	0.049	0.30
	0.065	0.02	0.014	0.014	Travel distance: $\pm 0.05/300$		0.049	0.30
	0.06	0.012	0.01	0.01	± 0.023	0.018	0.049	0.30
	0.075	0.02	0.014	0.014	Travel distance: $\pm 0.05/300$		0.049	0.30
	0.07	0.012	0.01	0.01	± 0.025	0.018	0.049	0.30
	0.09	0.02	0.014	0.014	Travel distance: $\pm 0.05/300$		0.049	0.30

BNK1002-3 Shaft diameter: 10; lead: 2

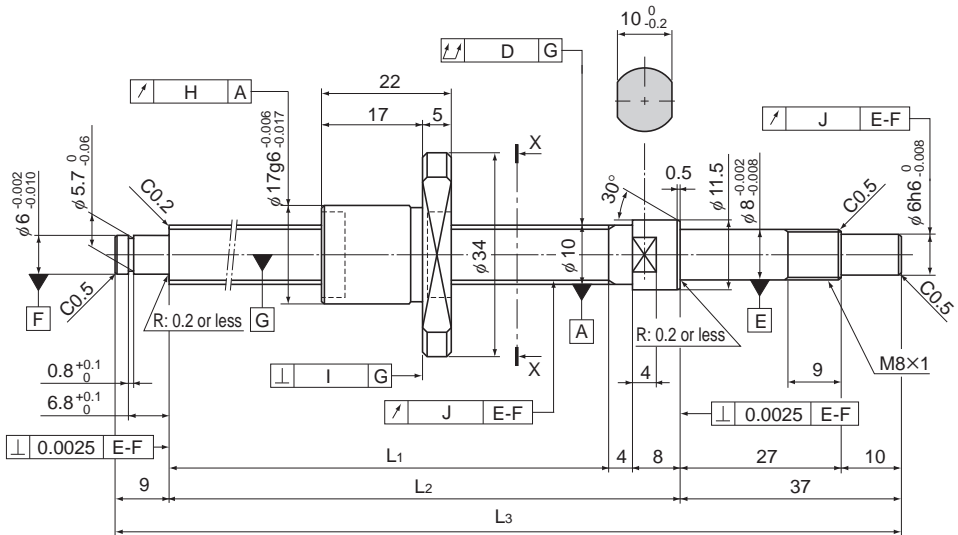

Model No.	Stroke	Screw shaft length		
		L ₁	L ₂	L ₃
BNK 1002-3RRG0+143LC3Y	50	85	97	143
BNK 1002-3RRG0+143LC5Y				
BNK 1002-3RRG2+143LC7Y				
BNK 1002-3RRG0+193LC3Y	100	135	147	193
BNK 1002-3RRG0+193LC5Y				
BNK 1002-3RRG2+193LC7Y				
BNK 1002-3RRG0+243LC3Y	150	185	197	243
BNK 1002-3RRG0+243LC5Y				
BNK 1002-3RRG2+243LC7Y				
BNK 1002-3RRG0+293LC3Y	200	235	247	293
BNK 1002-3RRG0+293LC5Y				
BNK 1002-3RRG2+293LC7Y				

Note) A stainless steel type is also available for model BNK1002. When placing an order, add symbol "M" to the end of the model number.

(Example) BNK1002-3RRG0+143LC3Y M

Symbol for stainless steel type

For accuracy grades C3 and C5, clearance GT is also available as standard.

Finished Shaft Ends Precision Ball Screw

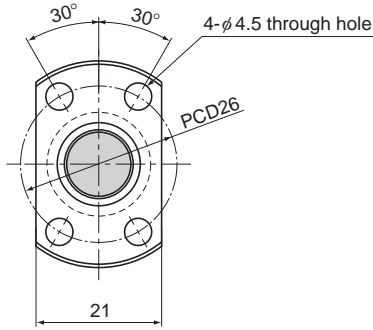

X-X arrow view

Ball Screw Specifications			
Lead (mm)	2		
BCD (mm)	10.3		
Thread minor diameter (mm)	9		
Threading direction, No. of threaded grooves	Rightward, 1		
No. of circuits	1 turn × 3 rows		
Clearance symbol	G0	GT	G2
Axial clearance (mm)	0	0.005 or less	0.02 or less
Basic dynamic load rating C_a (kN)	1.5	1.5	1.5
Basic static load rating C_{0a} (kN)	2.9	2.9	2.9
Preload torque (N-m)	to 2.5×10^2	—	—
Spacer ball	None	None	None
Rigidity value (N/μm)	100		
Circulation method	Deflector		

Unit: mm

	Runout of the screw shaft axis D	Runout of the nut circumference H	Flange perpendicularity I	Runout of the thread groove surface J	Lead angle accuracy		Nut mass kg	Shaft mass kg/m
					Representative travel distance error	Fluctuation		
	0.02	0.009	0.008	0.007	±0.008	0.008	0.045	0.47
	0.035	0.012	0.01	0.011	±0.018	0.018	0.045	0.47
	0.04	0.02	0.014	0.014	Travel distance: ±0.05/300		0.045	0.47
	0.03	0.009	0.008	0.007	±0.01	0.008	0.045	0.47
	0.035	0.012	0.01	0.011	±0.02	0.018	0.045	0.47
	0.04	0.02	0.014	0.014	Travel distance: ±0.05/300		0.045	0.47
	0.03	0.009	0.008	0.007	±0.01	0.008	0.045	0.47
	0.04	0.012	0.01	0.011	±0.02	0.018	0.045	0.47
	0.055	0.02	0.014	0.014	Travel distance: ±0.05/300		0.045	0.47
	0.03	0.009	0.008	0.007	±0.012	0.008	0.045	0.47
	0.04	0.012	0.01	0.011	±0.023	0.018	0.045	0.47
	0.055	0.02	0.014	0.014	Travel distance: ±0.05/300		0.045	0.47

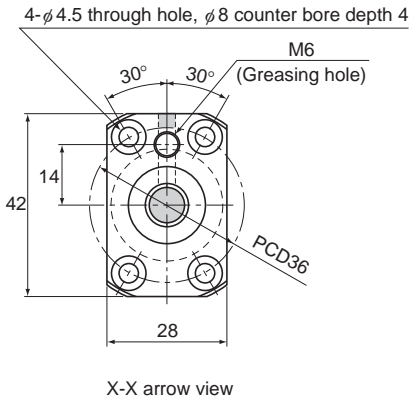

Ball Screw Specifications			
Lead (mm)	4		
BCD (mm)	10.5		
Thread minor diameter (mm)	7.8		
Threading direction, No. of threaded grooves	Rightward, 1		
No. of circuits	2.5 turns \times 1 row		
Clearance symbol	G0	GT	G2
Axial clearance (mm)	0	0.005 or less	0.02 or less
Basic dynamic load rating C_a (kN)	2.1	3.4	3.4
Basic static load rating C_{0a} (kN)	2.7	5.4	5.4
Preload torque (N-m)	9.8×10^{-3} to 4.9×10^{-2}	—	—
Spacer ball	1 : 1	None	None
Rigidity value (N/ μ m)	50	100	
Circulation method	Return pipe		

Unit: mm

	Runout of the screw shaft axis	Runout of the nut circumference	Flange perpendicularity	Runout of the thread groove surface	Lead angle accuracy		Nut mass kg	Shaft mass kg/m
					Representative travel distance error	Fluctuation		
	D	H	I	J				
	0.02	0.009	0.008	0.008	± 0.01	0.008	0.15	0.32
	0.035	0.012	0.01	0.011	± 0.02	0.018	0.15	0.32
	0.04	0.02	0.014	0.014	Travel distance: $\pm 0.05/300$		0.15	0.32
	0.03	0.009	0.008	0.008	± 0.01	0.008	0.15	0.32
	0.04	0.012	0.01	0.011	± 0.02	0.018	0.15	0.32
	0.055	0.02	0.014	0.014	Travel distance: $\pm 0.05/300$		0.15	0.32
	0.03	0.009	0.008	0.008	± 0.012	0.008	0.15	0.32
	0.04	0.012	0.01	0.011	± 0.023	0.018	0.15	0.32
	0.055	0.02	0.014	0.014	Travel distance: $\pm 0.05/300$		0.15	0.32
	0.04	0.009	0.008	0.008	± 0.012	0.008	0.15	0.32
	0.05	0.012	0.01	0.011	± 0.023	0.018	0.15	0.32
	0.065	0.02	0.014	0.014	Travel distance: $\pm 0.05/300$		0.15	0.32
	0.04	0.009	0.008	0.008	± 0.012	0.008	0.15	0.32
	0.05	0.012	0.01	0.011	± 0.023	0.018	0.15	0.32
	0.065	0.02	0.014	0.014	Travel distance: $\pm 0.05/300$		0.15	0.32

BNK1010-1.5 Shaft diameter: 10; lead: 10

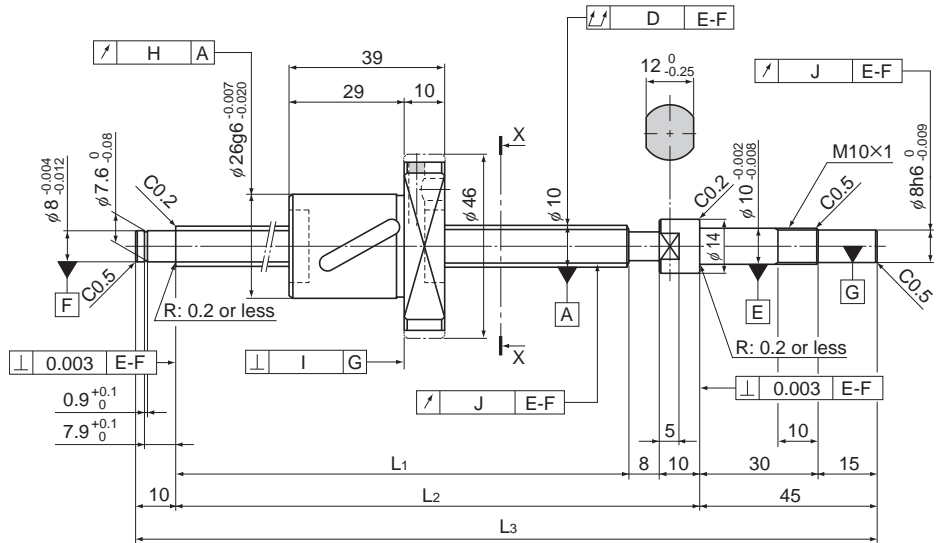

Model No.	Stroke	Screw shaft length		
		L ₁	L ₂	L ₃
BNK 1010-1.5RRG0+240LC5Y	100	167	185	240
BNK 1010-1.5RRG2+240LC7Y				
BNK 1010-1.5RRG0+290LC5Y	150	217	235	290
BNK 1010-1.5RRG2+290LC7Y				
BNK 1010-1.5RRG0+340LC5Y	200	267	285	340
BNK 1010-1.5RRG2+340LC7Y				
BNK 1010-1.5RRG0+390LC5Y	250	317	335	390
BNK 1010-1.5RRG2+390LC7Y				
BNK 1010-1.5RRG0+440LC5Y	300	367	385	440
BNK 1010-1.5RRG2+440LC7Y				

Note) For accuracy grade C5, clearance GT is also standardized.

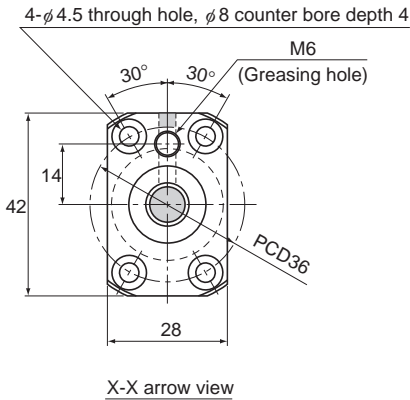

Ball Screw Specifications			
Lead (mm)	10		
BCD (mm)	10.5		
Thread minor diameter (mm)	7.8		
Threading direction, No. of threaded grooves	Rightward, 1		
No. of circuits	1.5 turns \times 1 row		
Clearance symbol	G0	GT	G2
Axial clearance (mm)	0	0.005 or less	0.02 or less
Basic dynamic load rating C_a (kN)	1.3	2.1	2.1
Basic static load rating C_{0a} (kN)	1.6	3.1	3.1
Preload torque (N-m)	9.8×10^3 to 4.9×10^2	—	—
Spacer ball	1 : 1	None	None
Rigidity value (N/ μ m)	70	140	
Circulation method	Return pipe		

Unit: mm

	Runout of the screw shaft axis D	Runout of the nut circumference H	Flange perpendicularity I	Runout of the thread groove surface J	Lead angle accuracy		Nut mass kg	Shaft mass kg/m
					Representative travel distance error	Fluctuation		
	0.04	0.012	0.01	0.011	± 0.02	0.018	0.17	0.5
	0.055	0.02	0.014	0.014	Travel distance: $\pm 0.05/300$		0.17	0.5
	0.04	0.012	0.01	0.011	± 0.023	0.018	0.17	0.5
	0.055	0.02	0.014	0.014	Travel distance: $\pm 0.05/300$		0.17	0.5
	0.05	0.012	0.01	0.011	± 0.023	0.018	0.17	0.5
	0.065	0.02	0.014	0.014	Travel distance: $\pm 0.05/300$		0.17	0.5
	0.05	0.012	0.01	0.011	± 0.025	0.02	0.17	0.5
	0.065	0.02	0.014	0.014	Travel distance: $\pm 0.05/300$		0.17	0.5
	0.065	0.012	0.01	0.011	± 0.025	0.02	0.17	0.5
	0.08	0.02	0.014	0.014	Travel distance: $\pm 0.05/300$		0.17	0.5

Finished Shaft Ends Precision Ball Screw

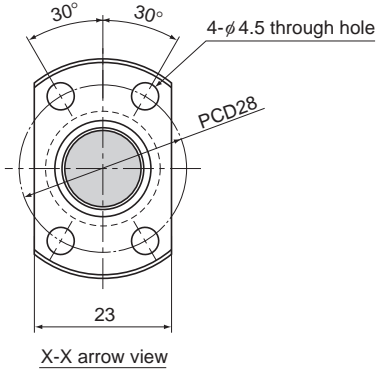

Ball Screw Specifications			
Lead (mm)	2		
BCD (mm)	12.3		
Thread minor diameter (mm)	11		
Threading direction, No. of threaded grooves	Rightward, 1		
No. of circuits	1 turn × 3 rows		
Clearance symbol	G0	GT	G2
Axial clearance (mm)	0	0.005 or less	0.02 or less
Basic dynamic load rating C_a (kN)	1.7	1.7	1.7
Basic static load rating C_{0a} (kN)	3.6	3.6	3.6
Preload torque (N-m)	4.0×10^3 to 3.4×10^2	—	—
Spacer ball	None	None	None
Rigidity value (N/μm)	120		
Circulation method	Deflector		

Unit: mm

	Runout of the screw shaft axis	Runout of the nut circumference	Flange perpendicularity	Runout of the thread groove surface	Lead angle accuracy		Nut mass kg	Shaft mass kg/m
					Representative travel distance error	Fluctuation		
	D	H	I	J				
	0.02	0.01	0.008	0.007	±0.008	0.008	0.05	0.71
	0.035	0.012	0.01	0.011	±0.018	0.018	0.05	0.71
	0.04	0.02	0.014	0.014	Travel distance: ±0.05/300		0.05	0.71
	0.03	0.01	0.008	0.007	±0.01	0.008	0.05	0.71
	0.04	0.012	0.01	0.011	±0.02	0.018	0.05	0.71
	0.055	0.02	0.014	0.014	Travel distance: ±0.05/300		0.05	0.71
	0.03	0.01	0.008	0.007	±0.01	0.008	0.05	0.71
	0.04	0.012	0.01	0.011	±0.02	0.018	0.05	0.71
	0.055	0.02	0.014	0.014	Travel distance: ±0.05/300		0.05	0.71
	0.04	0.01	0.008	0.007	±0.012	0.008	0.05	0.71
	0.05	0.012	0.01	0.011	±0.023	0.018	0.05	0.71
	0.055	0.02	0.014	0.014	Travel distance: ±0.05/300		0.05	0.71
	0.04	0.01	0.008	0.007	±0.012	0.008	0.05	0.71
	0.05	0.012	0.01	0.011	±0.023	0.018	0.05	0.71
	0.065	0.02	0.014	0.014	Travel distance: ±0.05/300		0.05	0.71

Ball Screw

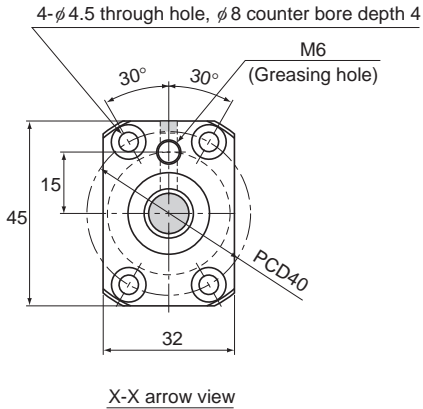

Ball Screw Specifications			
Lead (mm)	5		
BCD (mm)	12.3		
Thread minor diameter (mm)	9.6		
Threading direction, No. of threaded grooves	Rightward, 1		
No. of circuits	2.5 turns \times 1 row		
Clearance symbol	G0	GT	G2
Axial clearance (mm)	0	0.005 or less	0.02 or less
Basic dynamic load rating C_a (kN)	2.3	3.7	3.7
Basic static load rating C_{0a} (kN)	3.2	6.4	6.4
Preload torque (N-m)	9.8×10^3 to 4.9×10^2	—	—
Spacer ball	1 : 1	None	None
Rigidity value (N/ μ m)	60	120	
Circulation method	Return pipe		

Unit: mm

	Runout of the screw shaft axis	Runout of the nut circumference	Flange perpendicularity	Runout of the thread groove surface	Lead angle accuracy		Nut mass kg	Shaft mass kg/m
					Representative travel distance error	Fluctuation		
	D	H	I	J				
	0.02	0.009	0.008	0.008	± 0.01	0.008	0.22	0.61
	0.035	0.012	0.01	0.011	± 0.02	0.018	0.22	0.61
	0.04	0.02	0.014	0.014	Travel distance: $\pm 0.05/300$		0.22	0.61
	0.03	0.009	0.008	0.008	± 0.01	0.008	0.22	0.61
	0.04	0.012	0.01	0.011	± 0.02	0.018	0.22	0.61
	0.055	0.02	0.014	0.014	Travel distance: $\pm 0.05/300$		0.22	0.61
	0.03	0.009	0.008	0.008	± 0.012	0.008	0.22	0.61
	0.04	0.012	0.01	0.011	± 0.023	0.018	0.22	0.61
	0.055	0.02	0.014	0.014	Travel distance: $\pm 0.05/300$		0.22	0.61
	0.04	0.009	0.008	0.008	± 0.012	0.008	0.22	0.61
	0.05	0.012	0.01	0.011	± 0.023	0.018	0.22	0.61
	0.065	0.02	0.014	0.014	Travel distance: $\pm 0.05/300$		0.22	0.61
	0.04	0.009	0.008	0.008	± 0.012	0.008	0.22	0.61
	0.05	0.012	0.01	0.011	± 0.023	0.018	0.22	0.61
	0.065	0.02	0.014	0.014	Travel distance: $\pm 0.05/300$		0.22	0.61

BNK1208-2.6 Shaft diameter: 12; lead: 8

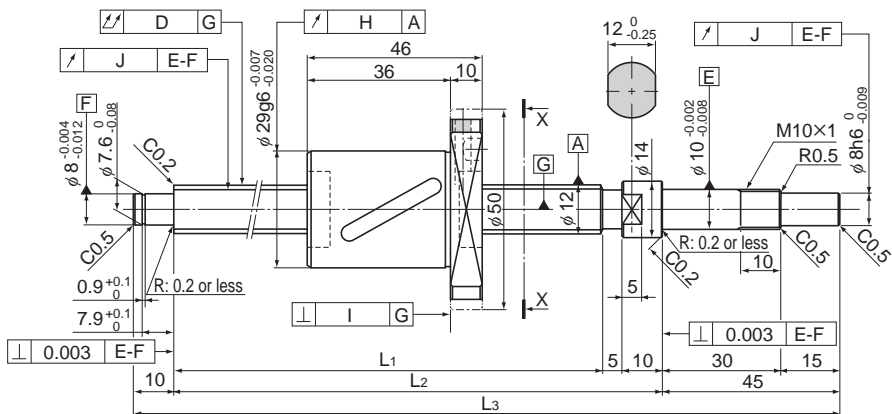

Model No.	Stroke	Screw shaft length		
		L ₁	L ₂	L ₃
BNK 1208-2.6RRG2+180LC7Y	50	110	125	180
BNK 1208-2.6RRG2+230LC7Y	100	160	175	230
BNK 1208-2.6RRG2+280LC7Y	150	210	225	280
BNK 1208-2.6RRG2+330LC7Y	200	260	275	330
BNK 1208-2.6RRG2+380LC7Y	250	310	325	380

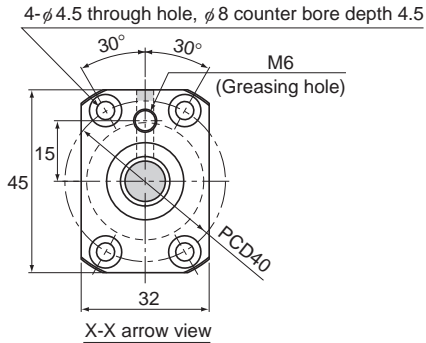

Ball Screw Specifications	
Lead (mm)	8
BCD (mm)	12.65
Thread minor diameter (mm)	9.7
Threading direction, No. of threaded grooves	Rightward, 1
No. of circuits	2.6 turns × 1 row
Clearance symbol	G2
Axial clearance (mm)	0.02 or less
Basic dynamic load rating C_a (kN)	4.7
Basic static load rating C_{0a} (kN)	7.5
Preload torque (N·m)	—
Spacer ball	None
Rigidity value (N/μm)	127
Circulation method	Return pipe

Unit: mm

	Runout of the screw shaft axis	Runout of the nut circumference	Flange perpendicularity	Runout of the thread groove surface	Lead angle accuracy	Nut mass	Shaft mass
	D	H	I	J		kg	kg/m
	0.04	0.02	0.014	0.014	Travel distance: $\pm 0.05/300$	0.269	0.64
	0.055	0.02	0.014	0.014	Travel distance: $\pm 0.05/300$	0.269	0.64
	0.055	0.02	0.014	0.014	Travel distance: $\pm 0.05/300$	0.269	0.64
	0.065	0.02	0.014	0.014	Travel distance: $\pm 0.05/300$	0.269	0.64
	0.065	0.02	0.014	0.014	Travel distance: $\pm 0.05/300$	0.269	0.64

BNK1402-3 Shaft diameter: 14; lead: 2

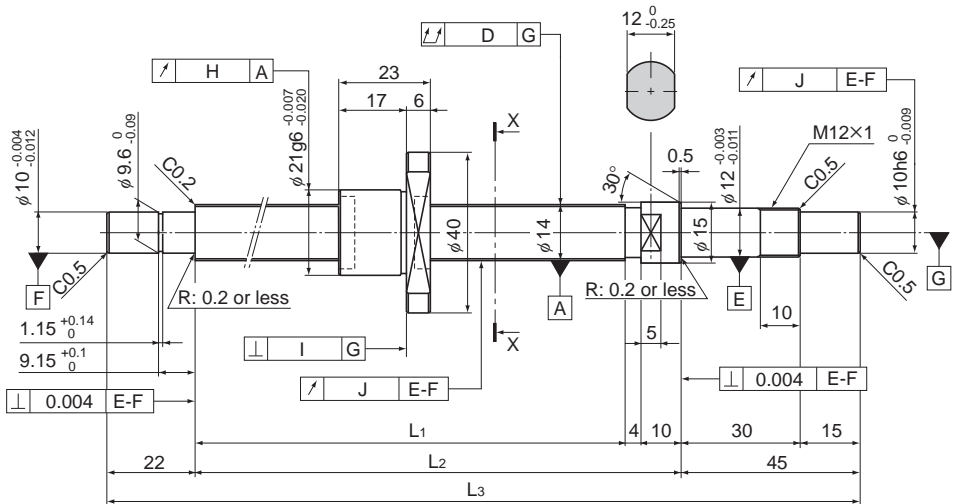

Model No.	Stroke	Screw shaft length		
		L ₁	L ₂	L ₃
BNK 1402-3RRG0+166LC3Y	50	85	99	166
BNK 1402-3RRG0+166LC5Y				
BNK 1402-3RRG2+166LC7Y				
BNK 1402-3RRG0+216LC3Y	100	135	149	216
BNK 1402-3RRG0+216LC5Y				
BNK 1402-3RRG2+216LC7Y				
BNK 1402-3RRG0+266LC3Y	150	185	199	266
BNK 1402-3RRG0+266LC5Y				
BNK 1402-3RRG2+266LC7Y				
BNK 1402-3RRG0+316LC3Y	200	235	249	316
BNK 1402-3RRG0+316LC5Y				
BNK 1402-3RRG2+316LC7Y				
BNK 1402-3RRG0+416LC3Y	300	335	349	416
BNK 1402-3RRG0+416LC5Y				
BNK 1402-3RRG2+416LC7Y				

Note) A stainless steel type is also available for model BNK1402. When placing an order, add symbol "M" to the end of the model number.

(Example) BNK1402-3RRG0+166LC3Y M

Symbol for stainless steel type

For accuracy grades C3 and C5, clearance GT is also available as standard.

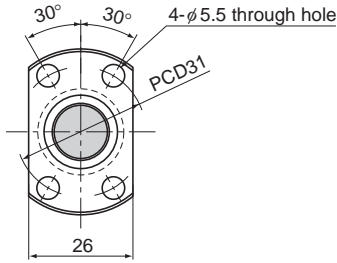

X-X arrow view

Ball Screw Specifications			
Lead (mm)	2		
BCD (mm)	14.3		
Thread minor diameter (mm)	13		
Threading direction, No. of threaded grooves	Rightward, 1		
No. of circuits	1 turn × 3 rows		
Clearance symbol	G0	GT	G2
Axial clearance (mm)	0	0.005 or less	0.02 or less
Basic dynamic load rating C_a (kN)	1.8	1.8	1.8
Basic static load rating C_{0a} (kN)	4.3	4.3	4.3
Preload torque (N-m)	4.9×10^3 to 4.9×10^2	—	—
Spacer ball	None	None	None
Rigidity value (N/μm)	140		
Circulation method	Deflector		

Unit: mm

	Runout of the screw shaft axis	Runout of the nut circumference	Flange perpendicularity	Runout of the thread groove surface	Lead angle accuracy		Nut mass kg	Shaft mass kg/m
					Representative travel distance error	Fluctuation		
	D	H	I	J				
	0.02	0.01	0.008	0.009	±0.008	0.008	0.15	1.0
	0.025	0.012	0.01	0.012	±0.018	0.018	0.15	1.0
	0.04	0.02	0.014	0.014	Travel distance: ±0.05/300		0.15	1.0
	0.025	0.01	0.008	0.009	±0.01	0.008	0.15	1.0
	0.03	0.012	0.01	0.012	±0.02	0.018	0.15	1.0
	0.045	0.02	0.014	0.014	Travel distance: ±0.05/300		0.15	1.0
	0.025	0.01	0.008	0.009	±0.01	0.008	0.15	1.0
	0.03	0.012	0.01	0.012	±0.02	0.018	0.15	1.0
	0.045	0.02	0.014	0.014	Travel distance: ±0.05/300		0.15	1.0
	0.03	0.01	0.008	0.009	±0.012	0.008	0.15	1.0
	0.04	0.012	0.01	0.012	±0.023	0.018	0.15	1.0
	0.055	0.02	0.014	0.014	Travel distance: ±0.05/300		0.15	1.0
	0.04	0.01	0.008	0.009	±0.013	0.01	0.15	1.0
	0.05	0.012	0.01	0.012	±0.025	0.02	0.15	1.0
	0.06	0.02	0.014	0.014	Travel distance: ±0.05/300		0.15	1.0

BNK1404-3 Shaft diameter: 14; lead: 4

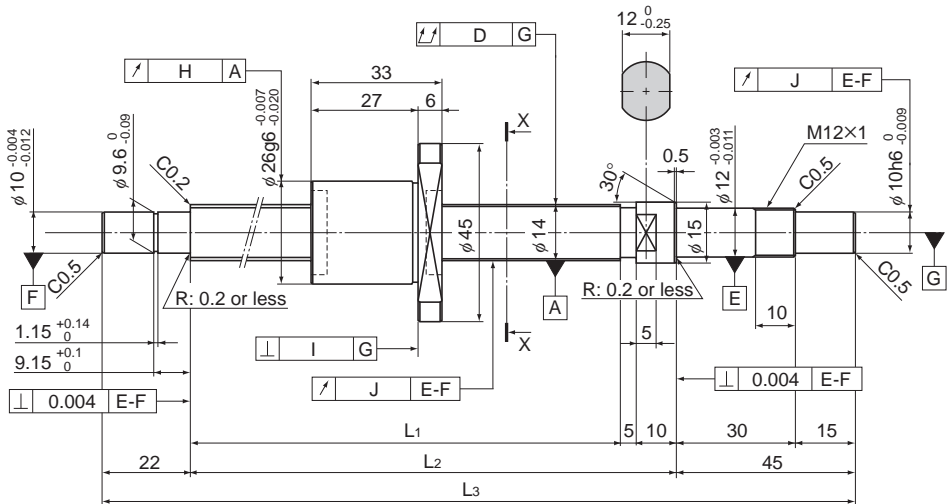

Model No.	Stroke	Screw shaft length		
		L ₁	L ₂	L ₃
BNK 1404-3RRG0+230LC3Y	100	148	163	230
BNK 1404-3RRG0+230LC5Y				
BNK 1404-3RRG2+230LC7Y				
BNK 1404-3RRG0+280LC3Y	150	198	213	280
BNK 1404-3RRG0+280LC5Y				
BNK 1404-3RRG2+280LC7Y				
BNK 1404-3RRG0+330LC3Y	200	248	263	330
BNK 1404-3RRG0+330LC5Y				
BNK 1404-3RRG2+330LC7Y				
BNK 1404-3RRG0+430LC3Y	300	348	363	430
BNK 1404-3RRG0+430LC5Y				
BNK 1404-3RRG2+430LC7Y				
BNK 1404-3RRG0+530LC3Y	400	448	463	530
BNK 1404-3RRG0+530LC5Y				
BNK 1404-3RRG2+530LC7Y				

Note) A stainless steel type is also available for model BNK1404. When placing an order, add symbol "M" to the end of the model number.

(Example) BNK1404-3RRG0+230LC3Y M

_____ Symbol for stainless steel type

For accuracy grades C3 and C5, clearance GT is also available as standard.

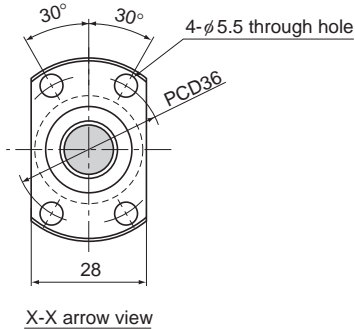

Ball Screw Specifications			
Lead (mm)	4		
BCD (mm)	14.65		
Thread minor diameter (mm)	12.2		
Threading direction, No. of threaded grooves	Rightward, 1		
No. of circuits	1 turn \times 3 rows		
Clearance symbol	G0	GT	G2
Axial clearance (mm)	0	0.005 or less	0.02 or less
Basic dynamic load rating C_a (kN)	4.2	4.2	4.2
Basic static load rating C_{0a} (kN)	7.6	7.6	7.6
Preload torque (N-m)	9.8×10^3 to 6.9×10^2	—	—
Spacer ball	None	None	None
Rigidity value (N/ μ m)	190		
Circulation method	Deflector		

Unit: mm

	Runout of the screw shaft axis D	Runout of the nut circumference H	Flange perpendicularity I	Runout of the thread groove surface J	Lead angle accuracy		Nut mass kg	Shaft mass kg/m
					Representative travel distance error	Fluctuation		
	0.025	0.01	0.008	0.009	± 0.01	0.008	0.13	0.8
	0.03	0.012	0.01	0.012	± 0.02	0.018	0.13	0.8
	0.045	0.02	0.014	0.014	Travel distance: $\pm 0.05/300$		0.13	0.8
	0.025	0.01	0.008	0.009	± 0.01	0.008	0.13	0.8
	0.03	0.012	0.01	0.012	± 0.02	0.018	0.13	0.8
	0.045	0.02	0.014	0.014	Travel distance: $\pm 0.05/300$		0.13	0.8
	0.03	0.01	0.008	0.009	± 0.012	0.008	0.13	0.8
	0.04	0.012	0.01	0.012	± 0.023	0.018	0.13	0.8
	0.055	0.02	0.014	0.014	Travel distance: $\pm 0.05/300$		0.13	0.8
	0.04	0.01	0.008	0.009	± 0.013	0.01	0.13	0.8
	0.05	0.012	0.01	0.012	± 0.025	0.02	0.13	0.8
	0.06	0.02	0.014	0.014	Travel distance: $\pm 0.05/300$		0.13	0.8
	0.045	0.01	0.008	0.009	± 0.015	0.01	0.13	0.8
	0.055	0.012	0.01	0.012	± 0.027	0.02	0.13	0.8
	0.075	0.02	0.014	0.014	Travel distance: $\pm 0.05/300$		0.13	0.8

BNK1408-2.5 Shaft diameter: 14; lead: 8

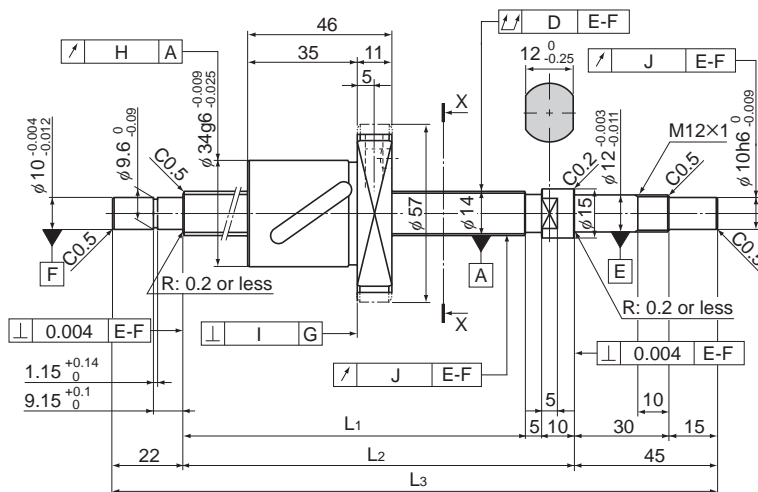

Model No.	Stroke	Screw shaft length		
		L ₁	L ₂	L ₃
BNK 1408-2.5RRG0+321LC5Y	150	239	254	321
BNK 1408-2.5RRG2+321LC7Y				
BNK 1408-2.5RRG0+371LC5Y	200	289	304	371
BNK 1408-2.5RRG2+371LC7Y				
BNK 1408-2.5RRG0+421LC5Y	250	339	354	421
BNK 1408-2.5RRG2+421LC7Y				
BNK 1408-2.5RRG0+471LC5Y	300	389	404	471
BNK 1408-2.5RRG2+471LC7Y				
BNK 1408-2.5RRG0+521LC5Y	350	439	454	521
BNK 1408-2.5RRG2+521LC7Y				
BNK 1408-2.5RRG0+571LC5Y	400	489	504	571
BNK 1408-2.5RRG2+571LC7Y				
BNK 1408-2.5RRG0+621LC5Y	450	539	554	621
BNK 1408-2.5RRG2+621LC7Y				
BNK 1408-2.5RRG0+671LC5Y	500	589	604	671
BNK 1408-2.5RRG2+671LC7Y				
BNK 1408-2.5RRG0+721LC5Y	550	639	654	721
BNK 1408-2.5RRG2+721LC7Y				
BNK 1408-2.5RRG0+771LC5Y	600	689	704	771
BNK 1408-2.5RRG2+771LC7Y				
BNK 1408-2.5RRG0+871LC5Y	700	789	804	871
BNK 1408-2.5RRG2+871LC7Y				

Note) For accuracy grade C5, clearance GT is also standardized.
Plug the unused oil hole before using the product.

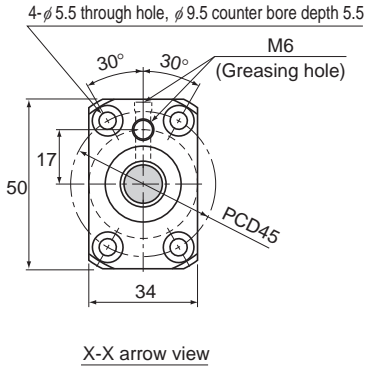

Ball Screw Specifications			
Lead (mm)	8		
BCD (mm)	14.75		
Thread minor diameter (mm)	11.2		
Threading direction, No. of threaded grooves	Rightward, 1		
No. of circuits	2.5 turns \times 1 row		
Clearance symbol	G0	GT	G2
Axial clearance (mm)	0	0.005 or less	0.02 or less
Basic dynamic load rating C_a (kN)	4.3	6.9	6.9
Basic static load rating C_{0a} (kN)	5.8	11.5	11.5
Preload torque (N-m)	2×10^2 to 7.8×10^2	—	—
Spacer ball	1 : 1	None	None
Rigidity value (N/ μ m)	80	150	
Circulation method	Return pipe		

Unit: mm

	Runout of the screw shaft axis	Runout of the nut circumference	Flange perpendicularity	Runout of the thread groove surface	Lead angle accuracy		Nut mass kg	Shaft mass kg/m
					Representative travel distance error	Fluctuation		
	D	H	I	J				
	0.035	0.015	0.011	0.012	± 0.023	0.018	0.29	0.84
	0.055	0.03	0.018	0.014	Travel distance: $\pm 0.05/300$		0.29	0.84
	0.035	0.015	0.011	0.012	± 0.023	0.018	0.29	0.84
	0.055	0.03	0.018	0.014	Travel distance: $\pm 0.05/300$		0.29	0.84
	0.04	0.015	0.011	0.012	± 0.025	0.02	0.29	0.84
	0.06	0.03	0.018	0.014	Travel distance: $\pm 0.05/300$		0.29	0.84
	0.04	0.015	0.011	0.012	± 0.025	0.02	0.29	0.84
	0.06	0.03	0.018	0.014	Travel distance: $\pm 0.05/300$		0.29	0.84
	0.05	0.015	0.011	0.012	± 0.027	0.02	0.29	0.84
	0.075	0.03	0.018	0.014	Travel distance: $\pm 0.05/300$		0.29	0.84
	0.05	0.015	0.011	0.012	± 0.027	0.02	0.29	0.84
	0.075	0.03	0.018	0.014	Travel distance: $\pm 0.05/300$		0.29	0.84
	0.05	0.015	0.011	0.012	± 0.03	0.023	0.29	0.84
	0.075	0.03	0.018	0.014	Travel distance: $\pm 0.05/300$		0.29	0.84
	0.065	0.015	0.011	0.012	± 0.03	0.023	0.29	0.84
	0.09	0.03	0.018	0.014	Travel distance: $\pm 0.05/300$		0.29	0.84
	0.065	0.015	0.011	0.012	± 0.035	0.025	0.29	0.84
	0.09	0.03	0.018	0.014	Travel distance: $\pm 0.05/300$		0.29	0.84
	0.065	0.015	0.011	0.012	± 0.035	0.025	0.29	0.84
	0.09	0.03	0.018	0.014	Travel distance: $\pm 0.05/300$		0.29	0.84
	0.085	0.015	0.011	0.012	± 0.035	0.025	0.29	0.84
	0.12	0.03	0.018	0.014	Travel distance: $\pm 0.05/300$		0.29	0.84

BNK1510-5.6 Shaft diameter: 15; lead: 10

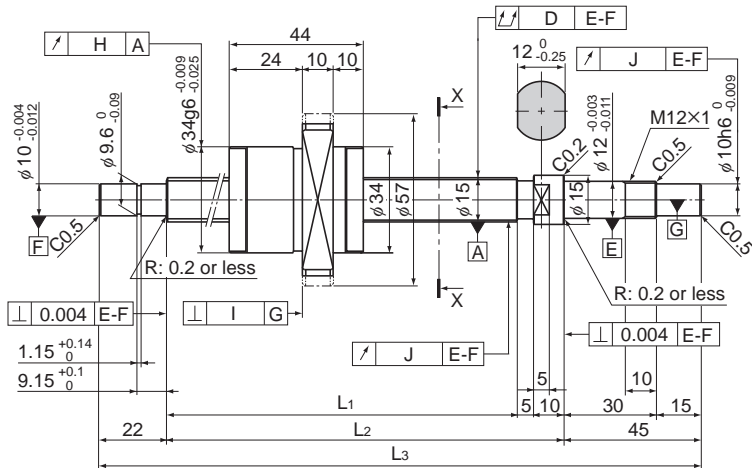

Model No.	Stroke	Screw shaft length		
		L ₁	L ₂	L ₃
BNK 1510-5.6G0+321LC5Y	150	239	254	321
BNK 1510-5.6G2+321LC7Y				
BNK 1510-5.6G0+371LC5Y	200	289	304	371
BNK 1510-5.6G2+371LC7Y				
BNK 1510-5.6G0+421LC5Y	250	339	354	421
BNK 1510-5.6G2+421LC7Y				
BNK 1510-5.6G0+471LC5Y	300	389	404	471
BNK 1510-5.6G2+471LC7Y				
BNK 1510-5.6G0+521LC5Y	350	439	454	521
BNK 1510-5.6G2+521LC7Y				
BNK 1510-5.6G0+571LC5Y	400	489	504	571
BNK 1510-5.6G2+571LC7Y				
BNK 1510-5.6G0+621LC5Y	450	539	554	621
BNK 1510-5.6G2+621LC7Y				
BNK 1510-5.6G0+671LC5Y	500	589	604	671
BNK 1510-5.6G2+671LC7Y				
BNK 1510-5.6G0+721LC5Y	550	639	654	721
BNK 1510-5.6G2+721LC7Y				
BNK 1510-5.6G0+771LC5Y	600	689	704	771
BNK 1510-5.6G2+771LC7Y				
BNK 1510-5.6G0+871LC5Y	700	789	804	871
BNK 1510-5.6G2+871LC7Y				
BNK 1510-5.6G0+971LC5Y	800	889	904	971
BNK 1510-5.6G2+971LC7Y				

Note) For accuracy grade C5, clearance GT is also standardized.

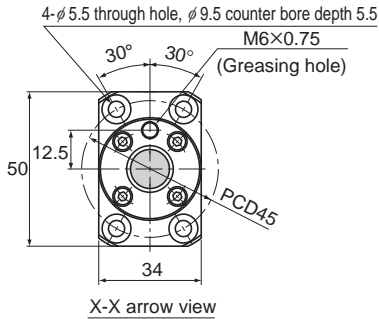

Ball Screw Specifications			
Lead (mm)	10		
BCD (mm)	15.75		
Thread minor diameter (mm)	12.5		
Threading direction, No. of threaded grooves	Rightward, 2		
No. of circuits	2.8 turns \times 2 rows		
Clearance symbol	G0	GT	G2
Axial clearance (mm)	0	0.005 or less	0.02 or less
Basic dynamic load rating C_a (kN)	9	14.3	14.3
Basic static load rating C_{0a} (kN)	13.9	27.9	27.9
Preload torque (N-m)	2×10^2 to 9.8×10^2	—	—
Spacer ball	1 : 1	None	None
Rigidity value (N/ μ m)	190	350	
Circulation method	End cap		

Unit: mm

	Runout of the screw shaft axis	Runout of the nut circumference	Flange perpendicularity	Runout of the thread groove surface	Lead angle accuracy		Nut mass kg	Shaft mass kg/m
					Representative travel distance error	Fluctuation		
	D	H	I	J				
	0.035	0.015	0.011	0.012	± 0.023	0.018	0.22	0.76
	0.055	0.03	0.018	0.014	Travel distance: $\pm 0.05/300$		0.22	0.76
	0.035	0.015	0.011	0.012	± 0.023	0.018	0.22	0.76
	0.055	0.03	0.018	0.014	Travel distance: $\pm 0.05/300$		0.22	0.76
	0.04	0.015	0.011	0.012	± 0.025	0.02	0.22	0.76
	0.06	0.03	0.018	0.014	Travel distance: $\pm 0.05/300$		0.22	0.76
	0.04	0.015	0.011	0.012	± 0.025	0.02	0.22	0.76
	0.06	0.03	0.018	0.014	Travel distance: $\pm 0.05/300$		0.22	0.76
	0.05	0.015	0.011	0.012	± 0.027	0.02	0.22	0.76
	0.075	0.03	0.018	0.014	Travel distance: $\pm 0.05/300$		0.22	0.76
	0.05	0.015	0.011	0.012	± 0.027	0.02	0.22	0.76
	0.075	0.03	0.018	0.014	Travel distance: $\pm 0.05/300$		0.22	0.76
	0.05	0.015	0.011	0.012	± 0.03	0.023	0.22	0.76
	0.075	0.03	0.018	0.014	Travel distance: $\pm 0.05/300$		0.22	0.76
	0.065	0.015	0.011	0.012	± 0.03	0.023	0.22	0.76
	0.09	0.03	0.018	0.014	Travel distance: $\pm 0.05/300$		0.22	0.76
	0.065	0.015	0.011	0.012	± 0.035	0.025	0.22	0.76
	0.09	0.03	0.018	0.014	Travel distance: $\pm 0.05/300$		0.22	0.76
	0.065	0.015	0.011	0.012	± 0.035	0.025	0.22	0.76
	0.09	0.03	0.018	0.014	Travel distance: $\pm 0.05/300$		0.22	0.76
	0.085	0.015	0.011	0.012	± 0.035	0.025	0.22	0.76
	0.12	0.03	0.018	0.014	Travel distance: $\pm 0.05/300$		0.22	0.76
	0.085	0.015	0.011	0.012	± 0.04	0.027	0.22	0.76
	0.12	0.03	0.018	0.014	Travel distance: $\pm 0.05/300$		0.22	0.76

BNK1520-3 Shaft diameter: 15; lead: 20

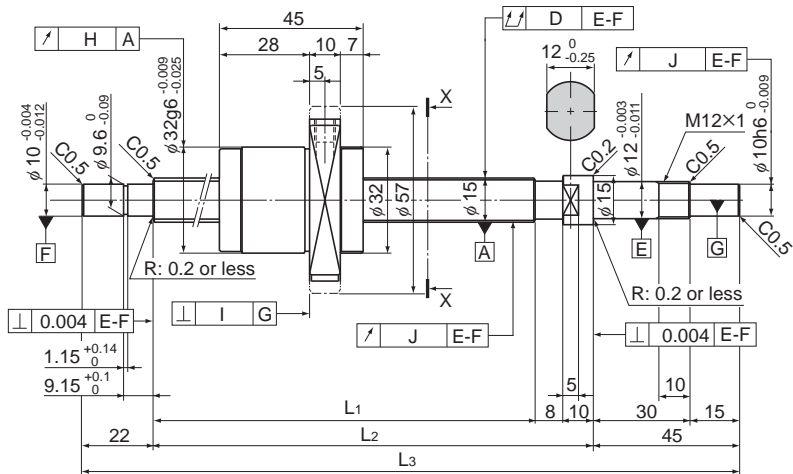

Model No.	Stroke	Screw shaft length		
		L ₁	L ₂	L ₃
BNK 1520-3G0+321LC5Y	150	236	254	321
BNK 1520-3G2+321LC7Y				
BNK 1520-3G0+371LC5Y				
BNK 1520-3G2+371LC7Y	200	286	304	371
BNK 1520-3G0+421LC5Y				
BNK 1520-3G2+421LC7Y				
BNK 1520-3G0+471LC5Y	250	336	354	421
BNK 1520-3G2+471LC7Y				
BNK 1520-3G0+521LC5Y				
BNK 1520-3G2+521LC7Y	300	436	454	521
BNK 1520-3G0+571LC5Y				
BNK 1520-3G2+571LC7Y				
BNK 1520-3G0+621LC5Y	350	486	504	571
BNK 1520-3G2+621LC7Y				
BNK 1520-3G0+671LC5Y				
BNK 1520-3G2+671LC7Y	400	536	554	621
BNK 1520-3G0+721LC5Y				
BNK 1520-3G2+721LC7Y				
BNK 1520-3G0+771LC5Y	450	586	604	671
BNK 1520-3G2+771LC7Y				
BNK 1520-3G0+821LC5Y				
BNK 1520-3G2+821LC7Y	500	636	654	721
BNK 1520-3G0+871LC5Y				
BNK 1520-3G2+871LC7Y				
BNK 1520-3G0+921LC5Y	550	686	704	771
BNK 1520-3G2+921LC7Y				
BNK 1520-3G0+971LC5Y				
BNK 1520-3G2+971LC7Y	600	736	754	821
BNK 1520-3G0+1021LC5Y				
BNK 1520-3G2+1021LC7Y				
BNK 1520-3G0+1071LC5Y	650	786	804	871
BNK 1520-3G2+1071LC7Y				
BNK 1520-3G0+1121LC5Y				
BNK 1520-3G2+1121LC7Y	700	836	854	921
BNK 1520-3G0+1171LC5Y				
BNK 1520-3G2+1171LC7Y				
BNK 1520-3G0+1221LC5Y	750	886	904	971
BNK 1520-3G2+1221LC7Y				
BNK 1520-3G0+1271LC5Y				
BNK 1520-3G2+1271LC7Y	800	936	954	1021
BNK 1520-3G0+1321LC5Y				
BNK 1520-3G2+1321LC7Y				

Note) For accuracy grade C5, clearance GT is also standardized.

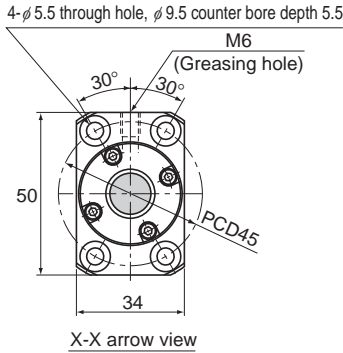

Ball Screw Specifications			
Lead (mm)	20		
BCD (mm)	15.75		
Thread minor diameter (mm)	12.5		
Threading direction, No. of threaded grooves	Rightward, 2		
No. of circuits	1.5 turns × 2 rows		
Clearance symbol	G0	GT	G2
Axial clearance (mm)	0	0.005 or less	0.02 or less
Basic dynamic load rating C_a (kN)	5.1	8	8
Basic static load rating C_{0a} (kN)	7.9	15.8	15.8
Preload torque (N-m)	2×10^2 to 8.8×10^2	—	—
Spacer ball	1 : 1	None	None
Rigidity value (N/μm)	110	200	
Circulation method	End cap		

Unit: mm

	Runout of the screw shaft axis	Runout of the nut circumference	Flange perpendicularity	Runout of the thread groove surface	Lead angle accuracy		Nut mass kg	Shaft mass kg/m
					Representative travel distance error	Fluctuation		
	D	H	I	J				
	0.035	0.015	0.011	0.012	±0.023	0.018	0.32	1.05
	0.055	0.03	0.018	0.014	Travel distance: ±0.05/300		0.32	1.05
	0.035	0.015	0.011	0.012	±0.023	0.018	0.32	1.05
	0.055	0.03	0.018	0.014	Travel distance: ±0.05/300		0.32	1.05
	0.04	0.015	0.011	0.012	±0.025	0.02	0.32	1.05
	0.06	0.03	0.018	0.014	Travel distance: ±0.05/300		0.32	1.05
	0.04	0.015	0.011	0.012	±0.025	0.02	0.32	1.05
	0.06	0.03	0.018	0.014	Travel distance: ±0.05/300		0.32	1.05
	0.05	0.015	0.011	0.012	±0.027	0.02	0.32	1.05
	0.075	0.03	0.018	0.014	Travel distance: ±0.05/300		0.32	1.05
	0.05	0.015	0.011	0.012	±0.027	0.02	0.32	1.05
	0.075	0.03	0.018	0.014	Travel distance: ±0.05/300		0.32	1.05
	0.05	0.015	0.011	0.012	±0.03	0.023	0.32	1.05
	0.075	0.03	0.018	0.014	Travel distance: ±0.05/300		0.32	1.05
	0.065	0.015	0.011	0.012	±0.03	0.023	0.32	1.05
	0.09	0.03	0.018	0.014	Travel distance: ±0.05/300		0.32	1.05
	0.065	0.015	0.011	0.012	±0.035	0.025	0.32	1.05
	0.09	0.03	0.018	0.014	Travel distance: ±0.05/300		0.32	1.05
	0.065	0.015	0.011	0.012	±0.035	0.025	0.32	1.05
	0.09	0.03	0.018	0.014	Travel distance: ±0.05/300		0.32	1.05
	0.085	0.015	0.011	0.012	±0.035	0.025	0.32	1.05
	0.12	0.03	0.018	0.014	Travel distance: ±0.05/300		0.32	1.05
	0.085	0.015	0.011	0.012	±0.04	0.027	0.32	1.05
	0.12	0.03	0.018	0.014	Travel distance: ±0.05/300		0.32	1.05

BNK1616-3.6 Shaft diameter: 16; lead: 16

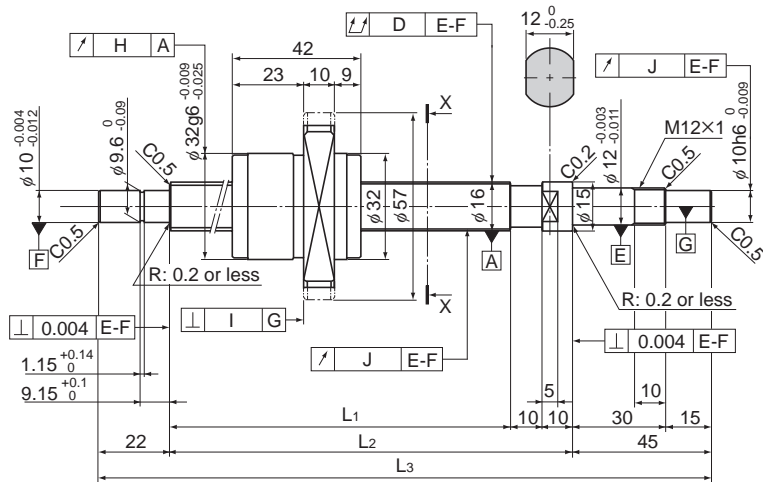

Model No.	Stroke	Screw shaft length		
		L ₁	L ₂	L ₃
BNK 1616-3.6G0+321LC5Y	150	234	254	321
BNK 1616-3.6G2+321LC7Y				
BNK 1616-3.6G0+371LC5Y	200	284	304	371
BNK 1616-3.6G2+371LC7Y				
BNK 1616-3.6G0+421LC5Y	250	334	354	421
BNK 1616-3.6G2+421LC7Y				
BNK 1616-3.6G0+471LC5Y	300	384	404	471
BNK 1616-3.6G2+471LC7Y				
BNK 1616-3.6G0+521LC5Y	350	434	454	521
BNK 1616-3.6G2+521LC7Y				
BNK 1616-3.6G0+571LC5Y	400	484	504	571
BNK 1616-3.6G2+571LC7Y				
BNK 1616-3.6G0+621LC5Y	450	534	554	621
BNK 1616-3.6G2+621LC7Y				
BNK 1616-3.6G0+671LC5Y	500	584	604	671
BNK 1616-3.6G2+671LC7Y				
BNK 1616-3.6G0+721LC5Y	550	634	654	721
BNK 1616-3.6G2+721LC7Y				
BNK 1616-3.6G0+771LC5Y	600	684	704	771
BNK 1616-3.6G2+771LC7Y				
BNK 1616-3.6G0+871LC5Y	700	784	804	871
BNK 1616-3.6G2+871LC7Y				
BNK 1616-3.6G0+971LC5Y	800	884	904	971
BNK 1616-3.6G2+971LC7Y				

Note) For accuracy grade C5, clearance GT is also standardized.

Finished Shaft Ends Precision Ball Screw

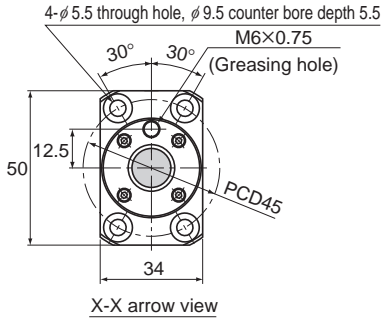

Ball Screw Specifications			
Lead (mm)	16		
BCD (mm)	16.65		
Thread minor diameter (mm)	13.7		
Threading direction, No. of threaded grooves	Rightward, 2		
No. of circuits	1.8 turns \times 2 rows		
Clearance symbol	G0	GT	G2
Axial clearance (mm)	0	0.005 or less	0.02 or less
Basic dynamic load rating C_a (kN)	4.4	7.1	7.1
Basic static load rating C_{0a} (kN)	7.2	14.3	14.3
Preload torque (N-m)	2×10^2 to 9.8×10^2	—	—
Spacer ball	1 : 1	None	None
Rigidity value (N/ μ m)	120	230	
Circulation method	End cap		

Unit: mm

	Runout of the screw shaft axis	Runout of the nut circumference	Flange perpendicularity	Runout of the thread groove surface	Lead angle accuracy		Nut mass kg	Shaft mass kg/m
					Representative travel distance error	Fluctuation		
	D	H	I	J				
	0.035	0.015	0.011	0.012	± 0.023	0.018	0.2	1.25
	0.055	0.03	0.018	0.014	Travel distance: $\pm 0.05/300$		0.2	1.25
	0.035	0.015	0.011	0.012	± 0.023	0.018	0.2	1.25
	0.055	0.03	0.018	0.014	Travel distance: $\pm 0.05/300$		0.2	1.25
	0.04	0.015	0.011	0.012	± 0.025	0.02	0.2	1.25
	0.06	0.03	0.018	0.014	Travel distance: $\pm 0.05/300$		0.2	1.25
	0.04	0.015	0.011	0.012	± 0.025	0.02	0.2	1.25
	0.06	0.03	0.018	0.014	Travel distance: $\pm 0.05/300$		0.2	1.25
	0.05	0.015	0.011	0.012	± 0.027	0.02	0.2	1.25
	0.075	0.03	0.018	0.014	Travel distance: $\pm 0.05/300$		0.2	1.25
	0.05	0.015	0.011	0.012	± 0.027	0.02	0.2	1.25
	0.075	0.03	0.018	0.014	Travel distance: $\pm 0.05/300$		0.2	1.25
	0.05	0.015	0.011	0.012	± 0.03	0.023	0.2	1.25
	0.075	0.03	0.018	0.014	Travel distance: $\pm 0.05/300$		0.2	1.25
	0.065	0.015	0.011	0.012	± 0.03	0.023	0.2	1.25
	0.09	0.03	0.018	0.014	Travel distance: $\pm 0.05/300$		0.2	1.25
	0.065	0.015	0.011	0.012	± 0.035	0.025	0.2	1.25
	0.09	0.03	0.018	0.014	Travel distance: $\pm 0.05/300$		0.2	1.25
	0.065	0.015	0.011	0.012	± 0.035	0.025	0.2	1.25
	0.09	0.03	0.018	0.014	Travel distance: $\pm 0.05/300$		0.2	1.25
	0.085	0.015	0.011	0.012	± 0.035	0.025	0.2	1.25
	0.12	0.03	0.018	0.014	Travel distance: $\pm 0.05/300$		0.2	1.25
	0.085	0.015	0.011	0.012	± 0.04	0.027	0.2	1.25
	0.12	0.03	0.018	0.014	Travel distance: $\pm 0.05/300$		0.2	1.25

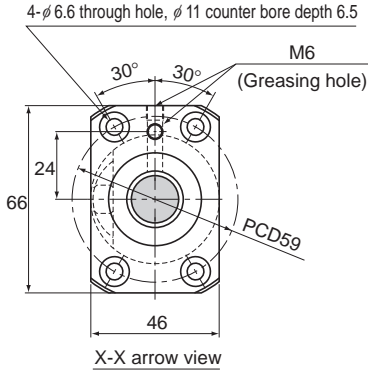

Ball Screw Specifications			
Lead (mm)	10		
BCD (mm)	21		
Thread minor diameter (mm)	16.4		
Threading direction, No. of threaded grooves	Rightward, 1		
No. of circuits	2.5 turns \times 1 row		
Clearance symbol	G0	GT	G2
Axial clearance (mm)	0	0.005 or less	0.02 or less
Basic dynamic load rating C_a (kN)	7	11.1	11.1
Basic static load rating C_{0a} (kN)	11	22	22
Preload torque (N-m)	2×10^2 to 9.8×10^2	—	—
Spacer ball	1 : 1	None	None
Rigidity value (N/ μ m)	110	210	
Circulation method	Return pipe		

Unit: mm

	Runout of the screw shaft axis	Runout of the nut circumference	Flange perpendicularity	Runout of the thread groove surface	Lead angle accuracy		Nut mass kg	Shaft mass kg/m
					Representative travel distance error	Fluctuation		
	D	H	I	J				
	0.04	0.015	0.011	0.012	± 0.025	0.02	0.58	1.81
	0.06	0.03	0.018	0.014	Travel distance: $\pm 0.05/300$		0.58	1.81
	0.05	0.015	0.011	0.012	± 0.027	0.02	0.58	1.81
	0.075	0.03	0.018	0.014	Travel distance: $\pm 0.05/300$		0.58	1.81
	0.065	0.015	0.011	0.012	± 0.03	0.023	0.58	1.81
	0.09	0.03	0.018	0.014	Travel distance: $\pm 0.05/300$		0.58	1.81
	0.065	0.015	0.011	0.012	± 0.035	0.025	0.58	1.81
	0.09	0.03	0.018	0.014	Travel distance: $\pm 0.05/300$		0.58	1.81
	0.085	0.015	0.011	0.012	± 0.035	0.025	0.58	1.81
	0.12	0.03	0.018	0.014	Travel distance: $\pm 0.05/300$		0.58	1.81
	0.085	0.015	0.011	0.012	± 0.04	0.027	0.58	1.81
	0.12	0.03	0.018	0.014	Travel distance: $\pm 0.05/300$		0.58	1.81
	0.11	0.015	0.011	0.012	± 0.04	0.027	0.58	1.81
	0.15	0.03	0.018	0.014	Travel distance: $\pm 0.05/300$		0.58	1.81
	0.11	0.015	0.011	0.012	± 0.046	0.03	0.58	1.81
	0.15	0.03	0.018	0.014	Travel distance: $\pm 0.05/300$		0.58	1.81
	0.15	0.015	0.011	0.012	± 0.046	0.03	0.58	1.81
	0.19	0.03	0.018	0.014	Travel distance: $\pm 0.05/300$		0.58	1.81

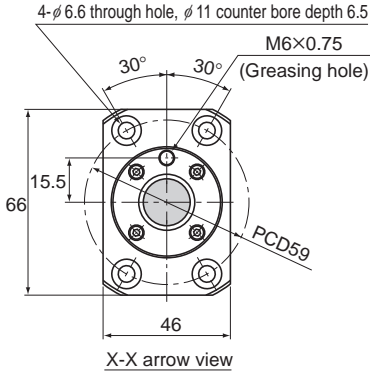

Ball Screw Specifications			
Lead (mm)	20		
BCD (mm)	20.75		
Thread minor diameter (mm)	17.5		
Threading direction, No. of threaded grooves	Rightward, 2		
No. of circuits	1.8 turns × 2 rows		
Clearance symbol	G0	GT	G2
Axial clearance (mm)	0	0.005 or less	0.02 or less
Basic dynamic load rating C_a (kN)	7	11.1	11.1
Basic static load rating C_{0a} (kN)	12.3	24.7	24.7
Preload torque (N-m)	2×10^2 to 9.8×10^2	—	—
Spacer ball	1 : 1	None	None
Rigidity value (N/μm)	160	290	
Circulation method	End cap		

Unit: mm

	Runout of the screw shaft axis	Runout of the nut circumference	Flange perpendicularity	Runout of the thread groove surface	Lead angle accuracy		Nut mass kg	Shaft mass kg/m
					Representative travel distance error	Fluctuation		
	D	H	I	J				
	0.05	0.015	0.011	0.012	±0.027	0.02	0.39	2.04
	0.075	0.03	0.018	0.014	Travel distance: ±0.05/300		0.39	2.04
	0.05	0.015	0.011	0.012	±0.03	0.023	0.39	2.04
	0.075	0.03	0.018	0.014	Travel distance: ±0.05/300		0.39	2.04
	0.065	0.015	0.011	0.012	±0.03	0.023	0.39	2.04
	0.09	0.03	0.018	0.014	Travel distance: ±0.05/300		0.39	2.04
	0.085	0.015	0.011	0.012	±0.035	0.025	0.39	2.04
	0.12	0.03	0.018	0.014	Travel distance: ±0.05/300		0.39	2.04
	0.085	0.015	0.011	0.012	±0.04	0.027	0.39	2.04
	0.12	0.03	0.018	0.014	Travel distance: ±0.05/300		0.39	2.04
	0.11	0.015	0.011	0.012	±0.04	0.027	0.39	2.04
	0.15	0.03	0.018	0.014	Travel distance: ±0.05/300		0.39	2.04
	0.11	0.015	0.011	0.012	±0.046	0.03	0.39	2.04
	0.15	0.03	0.018	0.014	Travel distance: ±0.05/300		0.39	2.04
	0.11	0.015	0.011	0.012	±0.046	0.03	0.39	2.04
	0.15	0.03	0.018	0.014	Travel distance: ±0.05/300		0.39	2.04
	0.15	0.015	0.011	0.012	±0.046	0.03	0.39	2.04
	0.19	0.03	0.018	0.014	Travel distance: ±0.05/300		0.39	2.04

BNK2520-3.6 Shaft diameter: 25; lead: 20

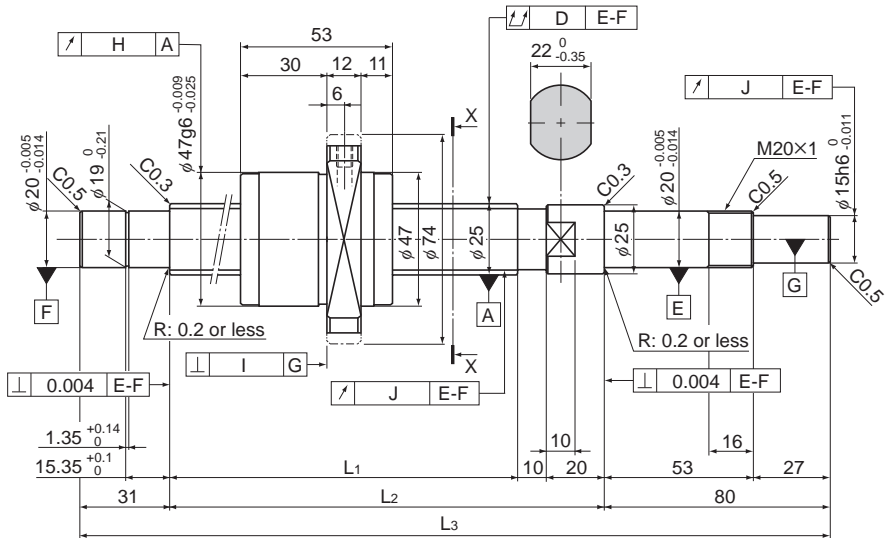

Model No.	Stroke	Screw shaft length		
		L ₁	L ₂	L ₃
BNK 2520-3.6G0+751LC5Y	500	610	640	751
BNK 2520-3.6G2+751LC7Y				
BNK 2520-3.6G0+851LC5Y	600	710	740	851
BNK 2520-3.6G2+851LC7Y				
BNK 2520-3.6G0+1051LC5Y	800	910	940	1051
BNK 2520-3.6G2+1051LC7Y				
BNK 2520-3.6G0+1251LC5Y	1000	1110	1140	1251
BNK 2520-3.6G2+1251LC7Y				
BNK 2520-3.6G0+1451LC5Y	1200	1310	1340	1451
BNK 2520-3.6G2+1451LC7Y				
BNK 2520-3.6G0+1651LC5Y	1400	1510	1540	1651
BNK 2520-3.6G2+1651LC7Y				
BNK 2520-3.6G0+1851LC5Y	1600	1710	1740	1851
BNK 2520-3.6G2+1851LC7Y				

Note) For accuracy grade C5, clearance GT is also standardized.

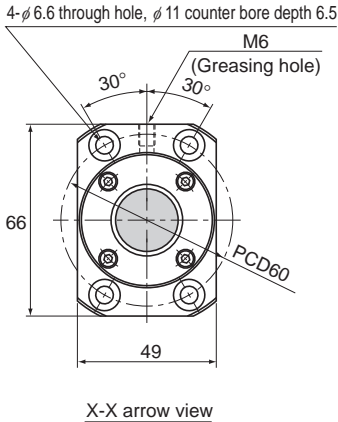

Ball Screw Specifications			
Lead (mm)	20		
BCD (mm)	26		
Thread minor diameter (mm)	21.9		
Threading direction, No. of threaded grooves	Rightward, 2		
No. of circuits	1.8 turns \times 2 rows		
Clearance symbol	G0	GT	G2
Axial clearance (mm)	0	0.005 or less	0.02 or less
Basic dynamic load rating C_a (kN)	10.5	16.7	16.7
Basic static load rating C_{0a} (kN)	19	38	38
Preload torque (N-m)	4.9×10^2 to 2.2×10^1	—	—
Spacer ball	1 : 1	None	None
Rigidity value (N/ μ m)	190	360	
Circulation method	End cap		

Unit: mm

	Runout of the screw shaft axis	Runout of the nut circumference	Flange perpendicularity	Runout of the thread groove surface	Lead angle accuracy		Nut mass kg	Shaft mass kg/m
					Representative travel distance error	Fluctuation		
	D	H	I	J				
	0.055	0.015	0.011	0.013	± 0.03	0.023	0.53	3.03
	0.07	0.03	0.018	0.02	Travel distance: $\pm 0.05/300$		0.53	3.03
	0.065	0.015	0.011	0.013	± 0.035	0.025	0.53	3.03
	0.085	0.03	0.018	0.02	Travel distance: $\pm 0.05/300$		0.53	3.03
	0.085	0.015	0.011	0.013	± 0.04	0.027	0.53	3.03
	0.1	0.03	0.018	0.02	Travel distance: $\pm 0.05/300$		0.53	3.03
	0.11	0.015	0.011	0.013	± 0.046	0.03	0.53	3.03
	0.13	0.03	0.018	0.02	Travel distance: $\pm 0.05/300$		0.53	3.03
	0.11	0.015	0.011	0.013	± 0.054	0.035	0.53	3.03
	0.13	0.03	0.018	0.02	Travel distance: $\pm 0.05/300$		0.53	3.03
	0.14	0.015	0.011	0.013	± 0.054	0.035	0.53	3.03
	0.17	0.03	0.018	0.02	Travel distance: $\pm 0.05/300$		0.53	3.03
	0.14	0.015	0.011	0.013	± 0.065	0.04	0.53	3.03
	0.17	0.03	0.018	0.02	Travel distance: $\pm 0.05/300$		0.53	3.03

Precision Ball Screw

Models BIF-V, DIK, BNFN-V/BNFN, DKN, BLW, BNF-V/BNF, DK, MDK, WHF, BLK/WGF and BNT

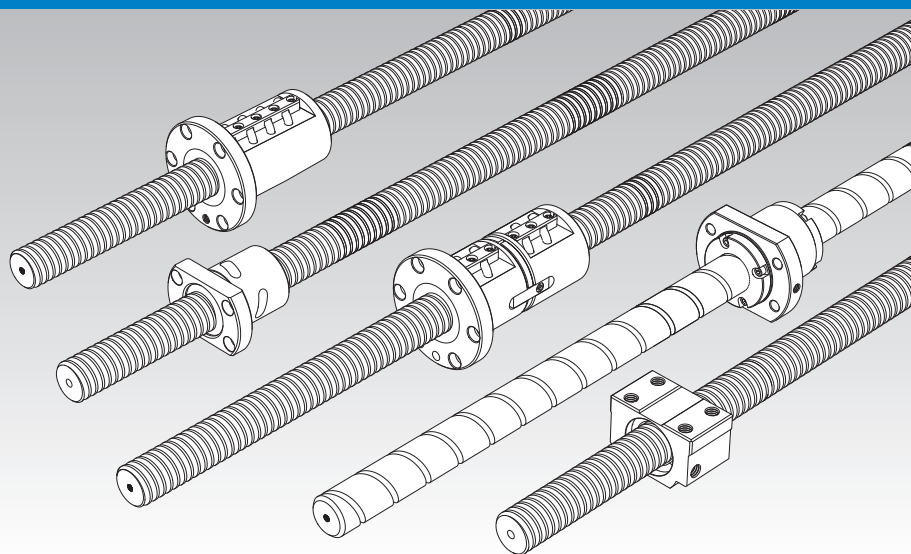

Point of Selection	A15-8
Options	A15-336
Model No.	A15-353
Precautions on Use	A15-358
Accessories for Lubrication	A24-1
Mounting Procedure and Maintenance	B15-104
Lead Angle Accuracy	A15-11
Accuracy of the Mounting Surface	A15-14
Axial Clearance	A15-19
Maximum Length of the Screw Shaft	A15-24
DN Value	A15-33
Support Unit	A15-300
Recommended Shapes of Shaft Ends	A15-308
Dimensions of Each Model with an Option Attached	A15-344

For THK Precision Ball Screws, a wide array of precision-ground screw shafts and ball screw nuts are available as standard to meet diversified applications.

Structure and Features

[Combinations of Various shaft Diameters and Leads]

You can select the combination of a shaft diameter and a lead that meet the intended use from the various nut types and the screw shaft leads. Those nut types include the return-pipe nuts, which represent the most extensive variations among the series, the compact simple nuts and the large-lead end-cap nuts.

[Screw Shaft Standard Products (Unfinished Shaft Ends/Finished Shaft Ends) Available]

The unfinished shaft end types, which are mass manufactured by cutting the standardized screw shafts to the standard lengths; and those with finished shaft ends, for which the screw shaft ends are machined to match the corresponding support units, are available as the standard.

[Accuracy Standards Compliant with JIS (ISO)]

The precision of the ball screw is controlled in accordance with JIS standards (JIS B1192-1997) and ISO 3408.

	Precision Ball Screw					Rolled Ball Screw		
	C0	C1	C2	C3	C5	C7	C8	C10
Accuracy grades	C0	C1	C2	C3	C5	C7	C8	C10

Type	Series symbol	Grade	Remarks
For positioning	C	0, 1, 3, 5	JIS series
	Cp	1, 3, 5	ISO compliant
For transport	Ct	1, 3, 5, 7, 10	

[Options that Meet the Environment are Available]

Options are available consisting of a lubricator (QZ), which enables the maintenance interval to be significantly extended, and a wiper ring (W), which improves the ability to remove foreign materials in adverse environments.

Types and Features

[Preload Type]

Model BIF-V

Specification Table⇒ **A15-184**

The right and the left screws are provided with a phase in the middle of the ball screw nut, and an axial clearance is set at a below-zero value (under a preload). This compact model is capable of a smooth motion.

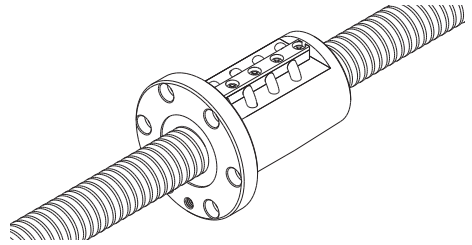

Model DIK

Specification Table⇒ **A15-190**

The right and the left screws are provided with a phase in the middle of the ball screw nut, and an axial clearance is set at a below-zero value (under a preload). This compact model is capable of a smooth motion.

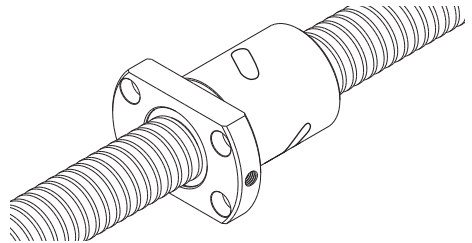

Models BNFN-V/BNFN

Specification Table⇒ **A15-196**

The most common type with a preload provided via a spacer between the two combined ball screw nuts to eliminate the backlash. It can be mounted using the bolt holes drilled on the flange.

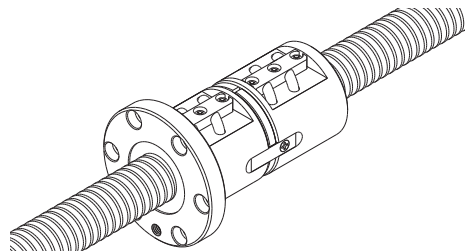

Model DKN

Specification Table⇒ **A15-202**

A preload is provided via a spacer between the two combined ball screw nuts to achieve a below-zero axial clearance (under a preload).

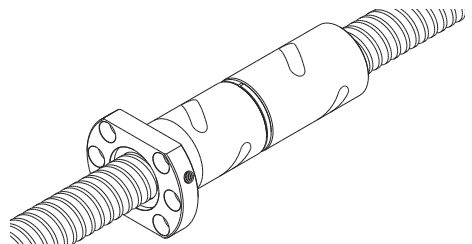

Model BLW

Since a preload is provided through a spacer between two large lead nuts, high-speed feed without backlash is ensured.

Specification Table⇒ **A15-203**

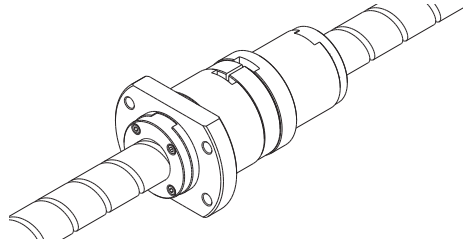

[No Preload Type]

Models BNF-V/BNF

The simplest type with a single ball screw nut. It is designed to be mounted using the bolt holes drilled on the flange.

Specification Table⇒ **A15-204**

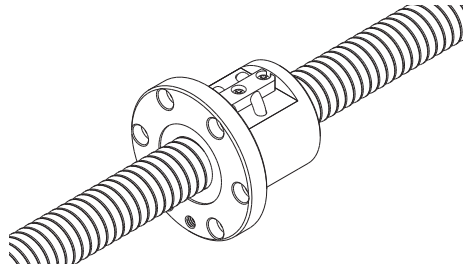

Model DK

The most compact type, with a ball screw nut diameter 70 to 80% of that of the return-pipe nut.

Specification Table⇒ **A15-214**

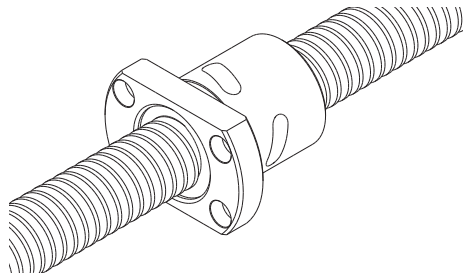

Model MDK

A miniature type with a screw shaft diameter of $\phi 4$ to $\phi 14$ mm and a lead of 1 to 5mm.

Specification Table⇒ **A15-222**

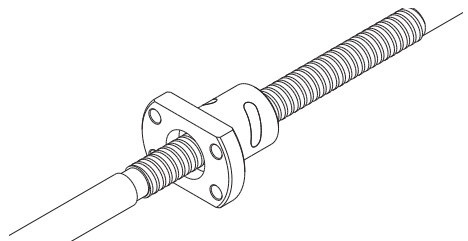

Model WHF

Specification Table⇒ **A15-223**

This Ball Screw for high-speed feed achieves a DN value of 120,000 by using a new circulation structure.

Since the nut outer diameter and the mounting holes of this model are dimensionally interchangeable with the previous model WGF, model WGF can be replaced with this model. (WHF1530, WHF2040 and WHF2550)

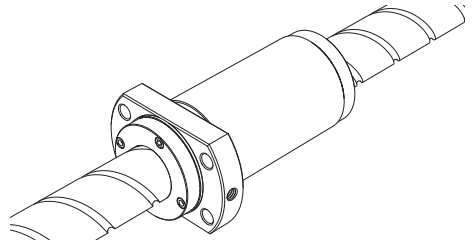

Models BLK/WGF

Specification Table⇒ **A15-224**

With model BLK, the shaft diameter is equal to the lead dimension. Model WGF has a lead dimension 1.5 to 3 times longer than the shaft diameter.

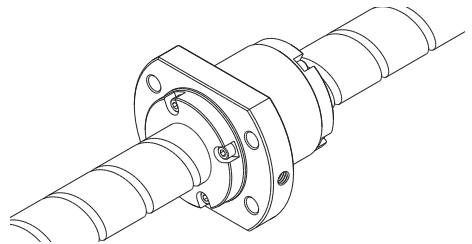

Square Ball Screw Nut Model BNT

Specification Table⇒ **A15-228**

Since mounting screw holes are machined on the square ball screw nut, this model can compactly be mounted on the machine without a housing.

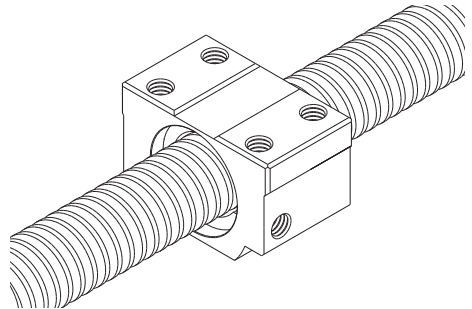

BIF-V Small With Preload

DN value	100000
----------	--------

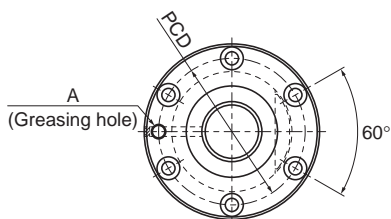

Model No.	Screw shaft outer diameter d	Lead Ph	Ball center-to-center diameter dp	Thread minor diameter dc	No. of loaded circuits Rows × turns	Basic load rating		Rigidity K N/μm
						Ca kN	C _{0a} kN	
BIF 1604V-5	16	4	16.5	13.8	1×2.5	4.3	8.7	298
BIF 1605V-5	16	5	16.75	13.2	1×2.5	7.4	13.9	330
BIF 2004V-5	20	4	20.5	17.8	1×2.5	4.8	10.9	360
BIF 2004V-10	20	4	20.5	17.8	2×2.5	8.6	21.8	692
BIF 2005V-5	20	5	20.75	17.2	1×2.5	8.3	17.5	390
BIF 2005V-10	20	5	20.75	17.2	2×2.5	15.1	35	762
BIF 2010V-5	20	10	20.75	17.2	1×2.5	8.3	17.6	766
BIF 2504V-5	25	4	25.5	22.8	1×2.5	5.2	13.7	426
BIF 2504V-10	25	4	25.5	22.8	2×2.5	9.5	27.4	824
BIF 2505V-5	25	5	25.75	22.2	1×2.5	9.2	21.9	470
BIF 2505V-10	25	5	25.75	22.2	2×2.5	16.7	43.9	910
BIF 2506V-5	25	6	26	21.4	1×2.5	12.4	27.4	482
BIF 2506V-10	25	6	26	21.4	2×2.5	22.6	54.8	934
BIF 2805V-5	28	5	28.75	25.2	1×2.5	9.7	24.6	520
BIF 2805V-10	28	5	28.75	25.2	2×2.5	17.5	49.2	1000
BIF 2806V-5	28	6	28.75	25.2	1×2.5	9.6	24.6	520
BIF 2806V-10	28	6	28.75	25.2	2×2.5	17.5	49.2	1000
BIF 3205V-5	32	5	32.75	29.2	1×2.5	10.2	28.1	570
BIF 3205V-10	32	5	32.75	29.2	2×2.5	18.5	56.3	1110
BIF 3206V-5	32	6	33	28.4	1×2.5	13.9	35.2	600
BIF 3206V-10	32	6	33	28.4	2×2.5	25.2	70.3	1150

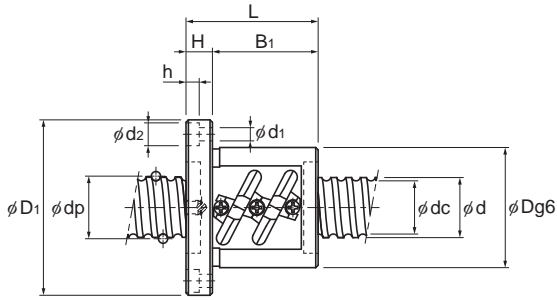

Unit: mm

	Nut dimensions								Screw shaft inertial moment/mm ² kg-cm ² /mm	Nut mass kg	Shaft mass kg/m
	Outer diameter	Flange diameter	Overall length	H	B ₁	PCD	d ₁ × d ₂ × h	Greasing hole			
	D	D ₁	L ₁	H	B ₁	PCD	d ₁ × d ₂ × h	A			
	36	59	53	11	42	47	5.5 × 9.5 × 5.5	M6	5.05 × 10 ⁻⁴	0.42	1.42
	40	60	56	10	46	50	4.5 × 8 × 4.5	M6	5.05 × 10 ⁻⁴	0.56	1.37
	40	63	49	11	38	51	5.5 × 9.5 × 5.5	M6	1.23 × 10 ⁻³	0.43	2.22
	40	63	73	11	62	51	5.5 × 9.5 × 5.5	M6	1.23 × 10 ⁻³	0.55	2.22
	44	67	56	11	45	55	5.5 × 9.5 × 5.5	M6	1.23 × 10 ⁻³	0.57	2.19
	44	67	86	11	75	55	5.5 × 9.5 × 5.5	M6	1.23 × 10 ⁻³	0.79	2.19
	46	74	90	15	75	59	5.5 × 9.5 × 5.5	M6	1.23 × 10 ⁻³	1.06	2.46
	46	69	48	11	37	57	5.5 × 9.5 × 5.5	M6	3.01 × 10 ⁻³	0.55	3.6
	46	69	72	11	61	57	5.5 × 9.5 × 5.5	M6	3.01 × 10 ⁻³	0.66	3.6
	50	73	55	11	44	61	5.5 × 9.5 × 5.5	M6	3.01 × 10 ⁻³	0.75	3.52
	50	73	85	11	74	61	5.5 × 9.5 × 5.5	M6	3.01 × 10 ⁻³	0.96	3.52
	53	76	62	11	51	64	5.5 × 9.5 × 5.5	M6	3.01 × 10 ⁻³	0.9	3.43
	53	76	98	11	87	64	5.5 × 9.5 × 5.5	M6	3.01 × 10 ⁻³	1.22	3.43
	55	85	59	12	47	69	6.6 × 11 × 6.5	M6	4.74 × 10 ⁻³	0.98	4.35
	55	85	89	12	77	69	6.6 × 11 × 6.5	M6	4.74 × 10 ⁻³	1.34	4.35
	55	85	68	12	56	69	6.6 × 11 × 6.5	M6	4.74 × 10 ⁻³	1.09	4.52
	55	85	104	12	92	69	6.6 × 11 × 6.5	M6	4.74 × 10 ⁻³	1.52	4.52
	58	85	56	12	44	71	6.6 × 11 × 6.5	M6	8.08 × 10 ⁻³	0.94	5.89
	58	85	86	12	74	71	6.6 × 11 × 6.5	M6	8.08 × 10 ⁻³	1.31	5.89
	62	89	63	12	51	75	6.6 × 11 × 6.5	M6	8.08 × 10 ⁻³	1.21	5.88
	62	89	99	12	87	75	6.6 × 11 × 6.5	M6	8.08 × 10 ⁻³	1.75	5.88

Note) The overall length of the nut will increase when equipping the QZ lubricating device. See **A15-344** for further details.
For model number coding, see **A15-230**.

BIF-V Medium With Preload

DN value	130000
----------	--------

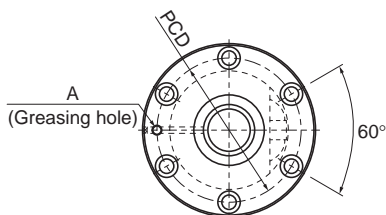

Model No.	Screw shaft outer diameter d	Lead Ph	Ball center-to-center diameter dp	Thread minor diameter dc	No. of loaded circuits Rows X turns	Basic load rating		Rigidity K N/μm
						Ca kN	C _{0a} kN	
BIF 2508V-5	25	8	26.25	20.5	1×2.5	15.8	32.9	500
BIF 2508V-7	25	8	26.25	20.5	1×3.5	21.1	46	688
BIF 2508V-10	25	8	26.25	20.5	2×2.5	28.7	65.7	968
BIF 2510V-5	25	10	26.25	21.5	1×2.5	15.8	32.9	500
BIF 2810V-3	28	10	29.75	22.4	1×1.5	15.6	29.4	350
BIF 3210V-5	32	10	33.75	26.4	1×2.5	26	56.2	640
BIF 3210V-7	32	10	33.75	26.4	1×3.5	34.8	78.6	874
BIF 3210V-10	32	10	33.75	26.4	2×2.5	47.3	112.3	1128
BIF 3212V-5	32	12	34	26.1	1×2.5	30.2	63.2	644
BIF 3212V-7	32	12	34	26.1	1×3.5	40.4	88.5	888
BIF 3216V-5	32	16	33.75	26.4	1×2.5	25.9	56.5	636
BIF 3610V-5	36	10	37.75	30.5	1×2.5	27.6	63.3	696
BIF 3610V-7	36	10	37.75	30.5	1×3.5	36.9	88.6	700
BIF 3610V-10	36	10	37.75	30.5	2×2.5	50.1	126.5	1350
BIF 3612V-5	36	12	38	30.1	1×2.5	32.2	71.2	708
BIF 3612V-7	36	12	38	30.1	1×3.5	43	99.6	976
BIF 3612V-10	36	12	38	30.1	2×2.5	58.4	142.3	1372
BIF 3616V-5	36	16	38	30.1	1×2.5	32.1	71.5	710
BIF 3620V-3	36	20	37.75	30.5	1×1.5	17.7	38.4	430
BIF 4010V-5	40	10	41.75	34.4	1×2.5	29	70.4	750
BIF 4010V-7	40	10	41.75	34.4	1×3.5	38.8	98.5	1044
BIF 4010V-10	40	10	41.75	34.4	2×2.5	52.7	140.7	1470
BIF 4012V-5	40	12	42	34.1	1×2.5	33.9	79.2	770
BIF 4012V-7	40	12	42	34.1	1×3.5	45.3	110.8	1062
BIF 4012V-10	40	12	42	34.1	2×2.5	61.6	158.3	1490
BIF 4016V-5	40	16	42	34.1	1×2.5	33.9	79.4	772
BIF 4020V-5	40	20	41.75	34.4	1×2.5	28.9	71	760

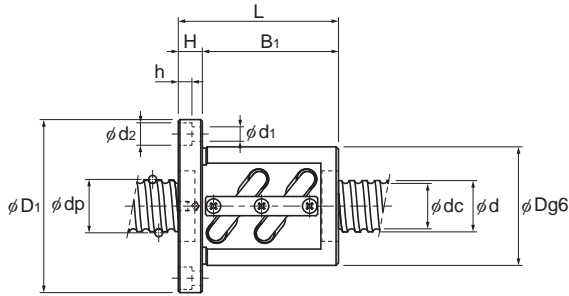

Unit: mm

	Nut dimensions								Screw shaft inertial moment/mm ³ kg-cm ² /mm	Nut mass kg	Shaft mass kg/m
	Outer diameter	Flange diameter	Overall length					Greasing hole			
	D	D ₁	L ₁	H	B ₁	PCD	d ₁ × d ₂ × h	A			
58	85	82	15	67	71	6.6 × 11 × 6.5	M6	3.01 × 10 ⁻³	1.52	3.51	
58	85	98	15	83	71	6.6 × 11 × 6.5	M6	3.01 × 10 ⁻³	1.5	3.51	
58	85	130	15	115	71	6.6 × 11 × 6.5	M6	3.01 × 10 ⁻³	1.93	3.51	
58	85	100	18	82	71	6.6 × 11 × 6.5	M6	3.01 × 10 ⁻³	1.31	3.5	
65	106	88	18	70	85	11 × 17.5 × 11	M6	4.74 × 10 ⁻³	2.33	4.15	
74	108	100	15	85	90	9 × 14 × 8.5	M6	8.08 × 10 ⁻³	2.92	5.53	
74	108	120	15	105	90	9 × 14 × 8.5	M6	8.08 × 10 ⁻³	3.1	5.53	
74	108	160	15	145	90	9 × 14 × 8.5	M6	8.08 × 10 ⁻³	4.27	5.53	
76	121	117	18	99	98	11 × 17.5 × 11	M6	8.08 × 10 ⁻³	3.7	5.7	
76	121	146	18	128	98	11 × 17.5 × 11	M6	8.08 × 10 ⁻³	3.7	5.7	
74	108	139	18	121	90	9 × 14 × 8.5	M6	8.08 × 10 ⁻³	3.81	5.82	
75	120	111	18	93	98	11 × 17.5 × 11	M6	1.29 × 10 ⁻²	3.45	7.1	
75	120	123	18	105	98	11 × 17.5 × 11	M6	1.29 × 10 ⁻²	3.82	7.1	
75	120	171	18	153	98	11 × 17.5 × 11	M6	1.29 × 10 ⁻²	4.84	7.1	
78	123	123	18	105	100	11 × 17.5 × 11	M6	1.29 × 10 ⁻²	4.69	7.99	
78	123	140	18	122	100	11 × 17.5 × 11	M6	1.29 × 10 ⁻²	4.34	7.99	
78	123	195	18	177	100	11 × 17.5 × 11	M6	1.29 × 10 ⁻²	5.67	7.99	
78	123	140	18	122	100	11 × 17.5 × 11	M6	1.29 × 10 ⁻²	4.31	7.99	
75	114	122	18	104	93	11 × 17.5 × 11	M6	1.29 × 10 ⁻²	3.4	7.54	
82	124	103	18	85	102	11 × 17.5 × 11	M6	1.97 × 10 ⁻²	3.61	8.87	
82	124	123	18	105	102	11 × 17.5 × 11	M6	1.97 × 10 ⁻²	3.97	8.87	
82	124	163	18	145	102	11 × 17.5 × 11	M6	1.97 × 10 ⁻²	5.33	8.87	
84	126	119	18	101	104	11 × 17.5 × 11	M6	1.97 × 10 ⁻²	4.36	8.83	
84	126	143	18	125	104	11 × 17.5 × 11	M6	1.97 × 10 ⁻²	4.92	8.83	
84	126	191	18	173	104	11 × 17.5 × 11	M6	1.97 × 10 ⁻²	6.47	8.83	
84	126	144	18	126	104	11 × 17.5 × 11	M6	1.97 × 10 ⁻²	4.9	9.09	
82	126	162	18	144	104	11 × 17.5 × 11	M6	1.97 × 10 ⁻²	5.17	9.37	

Note) The overall length of the nut will increase when equipping the QZ lubricating device. See [A15-344](#) for further details.
For model number coding, see [A15-230](#).

BIF-V Medium With Preload

DN value	130000
----------	--------

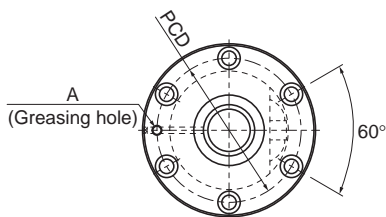

Model No.	Screw shaft outer diameter d	Lead Ph	Ball center-to-center diameter dp	Thread minor diameter dc	No. of loaded circuits Rows X turns	Basic load rating		Rigidity K N/μm
						Ca kN	C _{0a} kN	
BIF 4510V-5	45	10	46.75	39.5	1×2.5	30.6	79.3	830
BIF 4510V-10	45	10	46.75	39.5	2×2.5	55.6	158.5	1610
BIF 4512V-5	45	12	47	39.2	1×2.5	35.9	89.2	846
BIF 4512V-10	45	12	47	39.2	2×2.5	65.2	178.3	1638
BIF 4516V-5	45	16	47	39.2	1×2.5	35.8	89.4	846
BIF 4520V-5	45	20	47	39.2	1×2.5	35.8	89.7	848
BIF 5010V-5	50	10	51.75	44.4	1×2.5	32.1	88.1	900
BIF 5010V-7	50	10	51.75	44.4	1×3.5	42.9	123.4	1244
BIF 5010V-10	50	10	51.75	44.4	2×2.5	58.2	176.3	1750
BIF 5012V-5	50	12	52.25	43.3	1×2.5	43.4	110.1	934
BIF 5012V-7	50	12	52.25	43.3	1×3.5	58	154.1	1286
BIF 5012V-10	50	12	52.25	43.3	2×2.5	78.8	220.2	1808
BIF 5016V-5	50	16	52.7	42.9	1×2.5	72.6	183.1	1220
BIF 5016V-10	50	16	52.7	42.9	2×2.5	131.8	366.2	2364
BIF 5020V-5	50	20	52.7	42.9	1×2.5	72.5	183.6	1222

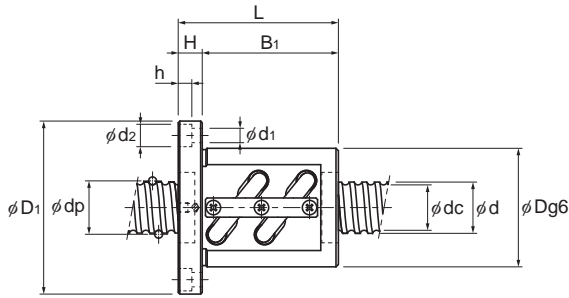

Unit: mm

	Nut dimensions								Screw shaft inertial moment/mm kg-cm ² /mm	Nut mass kg	Shaft mass kg/m
	Outer diameter	Flange diameter	Overall length					Greasing hole			
	D	D ₁	L ₁	H	B ₁	PCD	d ₁ × d ₂ × h	A			
	88	132	111	18	93	110	11 × 17.5 × 11	R1/8 (PT1/8)	3.16 × 10 ⁻²	4.29	12.48
	88	132	171	18	153	110	11 × 17.5 × 11	R1/8 (PT1/8)	3.16 × 10 ⁻²	5.97	12.48
	90	130	119	18	101	110	11 × 17.5 × 11	R1/8 (PT1/8)	3.16 × 10 ⁻²	4.6	11.32
	90	130	191	18	173	110	11 × 17.5 × 11	R1/8 (PT1/8)	3.16 × 10 ⁻²	6.67	11.32
	90	130	140	18	122	110	11 × 17.5 × 11	R1/8 (PT1/8)	3.16 × 10 ⁻²	5.3	11.61
	90	130	162	18	144	110	11 × 17.5 × 11	R1/8 (PT1/8)	3.16 × 10 ⁻²	5.96	11.1
	93	135	103	18	85	113	11 × 17.5 × 11	R1/8 (PT1/8)	4.82 × 10 ⁻²	4.28	14.16
	93	135	123	18	105	113	11 × 17.5 × 11	R1/8 (PT1/8)	4.82 × 10 ⁻²	4.94	14.16
	93	135	163	18	145	113	11 × 17.5 × 11	R1/8 (PT1/8)	4.82 × 10 ⁻²	6.26	14.16
	100	146	123	22	101	122	14 × 20 × 13	R1/8 (PT1/8)	4.82 × 10 ⁻²	6.12	13.82
	100	146	147	22	125	122	14 × 20 × 13	R1/8 (PT1/8)	4.82 × 10 ⁻²	7.06	13.82
	100	146	195	22	173	122	14 × 20 × 13	R1/8 (PT1/8)	4.82 × 10 ⁻²	8.91	13.82
	105	152	164	25	139	128	14 × 20 × 13	R1/8 (PT1/8)	4.82 × 10 ⁻²	8.82	13.71
	105	152	260	25	235	128	14 × 20 × 13	R1/8 (PT1/8)	4.82 × 10 ⁻²	12.3	13.71
	105	152	201	28	173	128	14 × 20 × 13	R1/8 (PT1/8)	4.82 × 10 ⁻²	10.63	14.05

Note) The overall length of the nut will increase when equipping the QZ lubricating device. See [A15-344](#) for further details.
For model number coding, see [A15-230](#).

DIK With Preload

DN value	70000
----------	-------

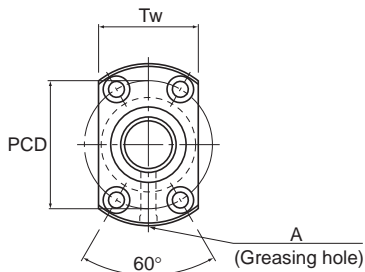

Model No.	Screw shaft outer diameter d	Lead Ph	Ball center-to-center diameter dp	Thread minor diameter dc	No. of loaded circuits Rows × turns	Basic load rating		Rigidity K N/μm
						Ca kN	C _{0a} kN	
DIK 1404-4	14	4	14.5	11.8	2×1	3	5.1	190
DIK 1404-6	14	4	14.5	11.8	3×1	4.2	7.7	280
DIK 1605-6	16	5	16.75	13.2	3×1	7.4	13	310
DIK 2004-6	20	4	20.5	17.8	3×1	5.2	11.6	380
DIK 2004-8	20	4	20.5	17.8	4×1	6.6	15.5	510
DIK 2005-6	20	5	20.75	17.2	3×1	8.5	17.3	310
DIK 2006-6	20	6	21	16.4	3×1	11.4	21.5	410
DIK 2008-4	20	8	21	16.4	2×1	8.1	14.4	280
DIK 2504-6	25	4	25.5	22.8	3×1	5.7	15	470
DIK 2504-8	25	4	25.5	22.8	4×1	7.4	19.9	620
DIK 2505-6	25	5	25.75	22.2	3×1	9.7	22.6	490
DIK 2506-4	25	6	26	21.4	2×1	9.1	18	330
DIK 2506-6	25	6	26	21.4	3×1	12.8	27	490
DIK 2508-4	25	8	26	21.4	2×1	9.2	18.8	340
DIK 2508-6	25	8	26	21.4	3×1	13.1	28.1	500
DIK 2510-4	25	10	26	21.6	2×1	9	18	330

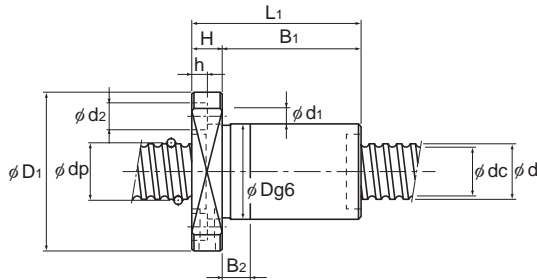

Unit: mm

	Nut dimensions										Screw shaft inertial moment/mm ²	Nut mass kg	Shaft mass kg/m
	Outer diameter D	Flange diameter D ₁	Overall length L ₁	H	B ₁	B ₂	PCD	d ₁ × d ₂ × h	Tw	Greasing hole A			
	26	45	48	10	38	10	35	4.5 × 8 × 4.5	29	M6	2.96 × 10 ⁻⁴	0.2	1
	26	45	60	10	50	10	35	4.5 × 8 × 4.5	29	M6	2.96 × 10 ⁻⁴	0.23	1
	30	49	60	10	50	10	39	4.5 × 8 × 4.5	31	M6	5.05 × 10 ⁻⁴	0.3	1.25
	32	56	62	11	51	15	44	5.5 × 9.5 × 5.5	35	M6	1.23 × 10 ⁻³	0.34	2.18
	32	56	70	11	59	15	44	5.5 × 9.5 × 5.5	35	M6	1.23 × 10 ⁻³	0.37	2.18
	34	58	61	11	50	10	46	5.5 × 9.5 × 5.5	36	M6	1.23 × 10 ⁻³	0.38	2.06
	35	58	76	11	65	15	46	5.5 × 9.5 × 5.5	36	M6	1.23 × 10 ⁻³	0.48	1.93
	35	58	69	11	58	15	46	5.5 × 9.5 × 5.5	36	M6	1.23 × 10 ⁻³	0.45	2.06
	38	63	63	11	52	15	51	5.5 × 9.5 × 5.5	39	M6	3.01 × 10 ⁻³	0.43	3.5
	38	63	71	11	60	15	51	5.5 × 9.5 × 5.5	39	M6	3.01 × 10 ⁻³	0.47	3.5
	40	63	61	11	50	10	51	5.5 × 9.5 × 5.5	41	M6	3.01 × 10 ⁻³	0.47	3.35
	40	63	60	11	49	10	51	5.5 × 9.5 × 5.5	41	M6	3.01 × 10 ⁻³	0.46	3.19
	40	63	72	11	61	15	51	5.5 × 9.5 × 5.5	41	M6	3.01 × 10 ⁻³	0.54	3.19
	40	63	71	12	59	15	51	5.5 × 9.5 × 5.5	41	M6	3.01 × 10 ⁻³	0.54	3.35
	40	63	94	12	82	25	51	5.5 × 9.5 × 5.5	41	M6	3.01 × 10 ⁻³	0.68	3.35
	40	63	85	15	70	20	51	5.5 × 9.5 × 5.5	41	M6	3.01 × 10 ⁻³	0.65	3.45

Note) The overall length of the nut will increase when equipping the QZ lubricating device. See [A15-344](#) for further details.
For model number coding, see [A15-230](#).

DIK With Preload

DN value	70000
----------	-------

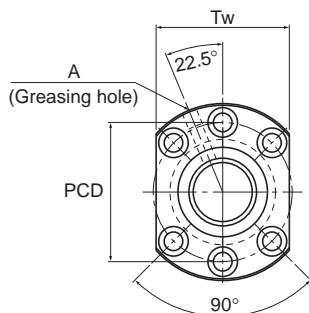

Model No.	Screw shaft outer diameter d	Lead Ph	Ball center-to-center diameter dp	Thread minor diameter dc	No. of loaded circuits Rows × turns	Basic load rating		Rigidity K N/μm
						Ca kN	C _{0a} kN	
DIK 2805-6	28	5	28.75	25.2	3 × 1	10.5	26.4	560
DIK 2805-8	28	5	28.75	25.2	4 × 1	13.4	35.2	730
DIK 2806-6	28	6	29	24.4	3 × 1	14	32	530
DIK 2810-4	28	10	29.25	23.6	2 × 1	12.3	25	380
DIK 3204-6	32	4	32.5	30.1	3 × 1	6.4	19.6	580
DIK 3204-8	32	4	32.5	30.1	4 × 1	8.2	26.1	760
DIK 3204-10	32	4	32.5	30.1	5 × 1	10	32.7	940
DIK 3205-6	32	5	32.75	29.2	3 × 1	11.1	30.2	620
DIK 3205-8	32	5	32.75	29.2	4 × 1	14.2	40.3	810
DIK 3206-6	32	6	33	28.4	3 × 1	14.9	37.1	630
DIK 3206-8	32	6	33	28.4	4 × 1	19.1	49.5	820
DIK 3210-6	32	10	33.75	26.4	3 × 1	25.7	52.2	600
DIK 3212-4	32	12	33.75	26.4	2 × 1	18.8	37	430
DIK 3610-6	36	10	37.75	30.5	3 × 1	28.8	63.8	710
DIK 3610-8	36	10	37.75	30.5	4 × 1	36.8	85	940
DIK 3610-10	36	10	37.75	30.5	5 × 1	44.6	106.3	1160

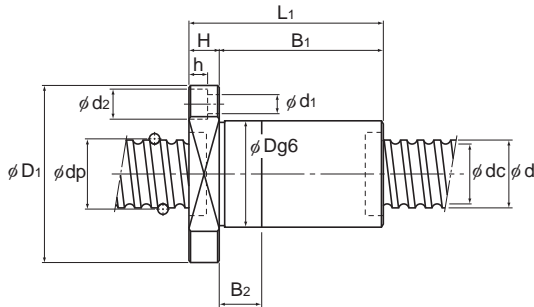

Unit: mm

	Nut dimensions										Screw shaft inertial moment/mm ³ kg-cm ² /mm	Nut mass kg	Shaft mass kg/m
	Outer diameter	Flange diameter	Overall length							Greasing hole			
	D	D ₁	L ₁	H	B ₁	B ₂	PCD	d ₁ × d ₂ × h	Tw	A			
	43	71	69	12	57	15	57	6.6 × 11 × 6.5	55	M6	4.74 × 10 ⁻³	0.61	4.27
	43	71	79	12	67	20	57	6.6 × 11 × 6.5	55	M6	4.74 × 10 ⁻³	0.68	4.27
	43	71	73	12	61	15	57	6.6 × 11 × 6.5	55	M6	4.74 × 10 ⁻³	0.64	4.36
	45	71	84	15	69	20	57	6.6 × 11 × 6.5	55	M6	4.74 × 10 ⁻³	0.82	4.18
	45	76	64	11	53	15	63	6.6 × 11 × 6.5	59	M6	8.08 × 10 ⁻³	0.57	5.86
	45	76	72	11	61	15	63	6.6 × 11 × 6.5	59	M6	8.08 × 10 ⁻³	0.62	5.86
	45	76	80	11	69	20	63	6.6 × 11 × 6.5	59	M6	8.08 × 10 ⁻³	0.66	5.86
	46	76	62	12	50	10	63	6.6 × 11 × 6.5	59	M6	8.08 × 10 ⁻³	0.6	5.67
	46	76	73	12	61	15	63	6.6 × 11 × 6.5	59	M6	8.08 × 10 ⁻³	0.67	5.67
	48	76	73	12	61	15	63	6.6 × 11 × 6.5	59	M6	8.08 × 10 ⁻³	0.74	6.31
	48	76	87	12	75	20	63	6.6 × 11 × 6.5	59	M6	8.08 × 10 ⁻³	0.85	6.31
	54	87	110	15	95	25	69	9 × 14 × 8.5	66	M6	8.08 × 10 ⁻³	1.57	4.98
	54	87	98	15	83	25	69	9 × 14 × 8.5	66	M6	8.08 × 10 ⁻³	1.43	5.2
	58	98	122	18	104	30	77	11 × 17.5 × 11	75	M6	1.29 × 10 ⁻²	2.03	6.51
	58	98	143	18	125	35	77	11 × 17.5 × 11	75	M6	1.29 × 10 ⁻²	2.3	6.51
	58	98	164	18	146	45	77	11 × 17.5 × 11	75	M6	1.29 × 10 ⁻²	2.57	6.51

Note) The overall length of the nut will increase when equipping the QZ lubricating device. See **■15-344** for further details.
For model number coding, see **■15-230**.

DIK With Preload

DN value	70000
----------	-------

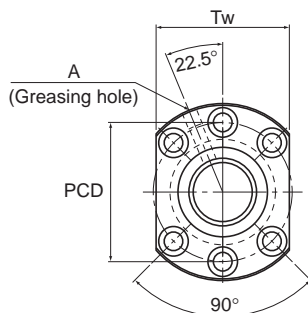

Model No.	Screw shaft outer diameter d	Lead Ph	Ball center-to-center diameter dp	Thread minor diameter dc	No. of loaded circuits Rows × turns	Basic load rating		Rigidity K N/μm
						Ca kN	C _{0a} kN	
DIK 4010-6	40	10	41.75	34.7	3 × 1	29.8	69.3	750
DIK 4010-8	40	10	41.75	34.7	4 × 1	38.1	92.4	1000
DIK 4012-6	40	12	41.75	34.4	3 × 1	30.6	72.3	790
DIK 4012-8	40	12	41.75	34.4	4 × 1	39.2	96.4	1030
DIK 4016-4	40	16	41.75	34.4	2 × 1	21.5	68.4	540
DIK 5010-6	50	10	51.75	44.4	3 × 1	33.9	90.7	940
DIK 5010-8	50	10	51.75	44.4	4 × 1	43.4	120.5	1230
DIK 5010-10	50	10	51.75	44.4	5 × 1	52.5	150.9	1530
DIK 5012-6	50	12	52.25	43.3	3 × 1	45.8	113	970
DIK 5012-8	50	12	52.25	43.3	4 × 1	58.6	150.6	1270
DIK 5016-4	50	16	52.25	43.3	2 × 1	32.3	75.5	660
DIK 5016-6	50	16	52.25	43.3	3 × 1	45.7	113.3	970

BNFN-V Small/Medium With Preload

DN value	Small	100000
	Medium	130000

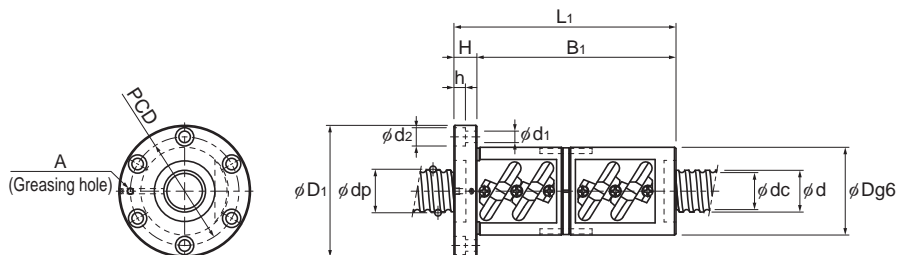

<Small> BNFN1605V/2805V/2806V/3205V

Model No.	Screw shaft outer diameter d	Lead Ph	Ball center-to-center diameter dp	Thread minor diameter dc	No. of loaded circuits Rows X turns	Basic load rating		Rigidity K N/μm
						Ca kN	C0a kN	
BNFN 1605V-5	16	5	16.75	13.2	2 × 2.5	13.5	27.9	640
BNFN 2805V-7.5	28	5	28.75	25.2	3 × 2.5	24.8	73.8	1470
BNFN 2806V-7.5	28	6	28.75	25.2	3 × 2.5	24.8	73.8	1470
BNFN 3205V-7.5	32	5	32.75	29.2	3 × 2.5	26.2	84.4	1640
BNFN 2810V-2.5	28	10	29.75	22.4	1 × 2.5	24.3	49	560
BNFN 3610V-7.5	36	10	37.75	30.5	3 × 2.5	71	189.8	1990
BNFN 3616V-5	36	16	38	30.1	2 × 2.5	58.3	142.9	1380
BNFN 4016V-5	40	16	42	34.1	2 × 2.5	61.5	158.8	1500
BNFN 4510V-7.5	45	10	46.75	39.5	3 × 2.5	78.8	237.8	2370
BNFN 5010V-7.5	50	10	51.75	44.4	3 × 2.5	82.5	264.4	2580

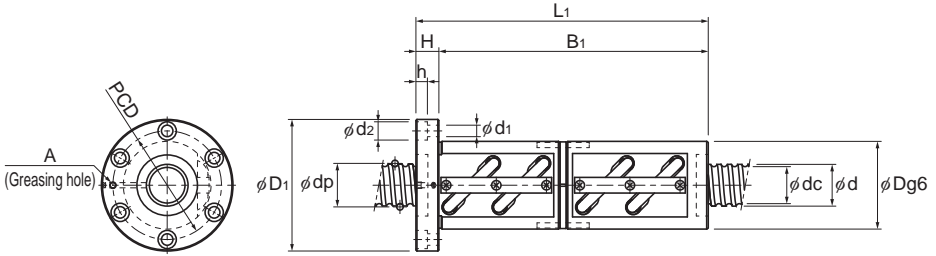

<Medium> BNFN2810V/3610V/3616V/4016V/4510V/5010V

Unit: mm

	Nut dimensions								Screw shaft inertial moment/mm kg-cm ² /mm	Nut mass kg	Shaft mass kg/m
	Outer diameter	Flange diameter	Overall length	H	B ₁	PCD	d ₁ × d ₂ × h	Greasing hole			
	D	D ₁	L ₁					A			
	40	60	106	10	96	50	4.5 × 8 × 4.5	M6	5.05 × 10 ⁻⁴	0.88	1.37
	55	85	134	12	122	69	6.6 × 11 × 6.5	M6	4.74 × 10 ⁻³	1.88	4.45
	55	85	158	12	149	69	6.6 × 11 × 6.5	M6	4.74 × 10 ⁻³	2.16	4.52
	58	85	136	12	124	71	6.6 × 11 × 6.5	M6	8.08 × 10 ⁻³	1.93	5.89
	65	106	146	18	128	85	11 × 17.5 × 11	M6	4.74 × 10 ⁻³	3.41	4.15
	75	120	261	18	243	98	11 × 17.5 × 11	M6	1.29 × 10 ⁻³	6.93	7.1
	78	123	268	18	250	100	11 × 17.5 × 11	M6	1.29 × 10 ⁻³	7.8	7.99
	84	126	280	22	258	104	11 × 17.5 × 11	M6	1.97 × 10 ⁻²	9.27	9.09
	88	132	261	18	243	110	11 × 17.5 × 11	R1/8 (PT1/8)	3.16 × 10 ⁻²	8.92	11.36
	93	135	253	18	235	113	11 × 17.5 × 11	R1/8 (PT1/8)	4.82 × 10 ⁻²	9.19	14.16

Note) The overall length of the nut will increase when equipping the QZ lubricating device. See [A15-344](#) for further details.
For model number coding, see [A15-230](#).

BNFN With Preload

DN value	70000
----------	-------

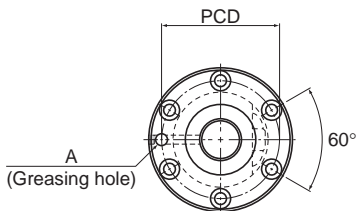

Model No.	Screw shaft outer diameter d	Lead Ph	Ball center-to-center diameter dp	Thread minor diameter dc	No. of loaded circuits Rows X turns	Basic load rating		Rigidity K N/μm
						Ca kN	C _{0a} kN	
BNFN 5510-2.5	55	10	56.75	49.5	1×2.5	33.4	97	970
BNFN 5510-5	55	10	56.75	49.5	2×2.5	60.7	194	1890
BNFN 5510-7.5	55	10	56.75	49.5	3×2.5	85.9	291.1	2770
BNFN 5512-2.5	55	12	57	49.2	1×2.5	39.3	108.8	990
BNFN 5512-3	55	12	57	49.2	2×1.5	46	131.3	1180
BNFN 5512-3.5	55	12	57	49.2	1×3.5	52.4	152.9	1360
BNFN 5512-5	55	12	57	49.2	2×2.5	71.3	218.5	1920
BNFN 5512-7.5	55	12	57	49.2	3×2.5	100.9	327.3	2830
BNFN 5516-2.5	55	16	57.7	47.9	1×2.5	76.1	201.9	1310
BNFN 5516-5	55	16	57.7	47.9	2×2.5	138.2	402.8	2550
BNFN 5520-2.5	55	20	57.7	47.9	1×2.5	76	201.9	1320
BNFN 5520-5	55	20	57.7	47.9	2×2.5	138.2	403.8	2550
BNFN 6310-2.5	63	10	64.75	57.7	1×2.5	35.4	111.7	1090
BNFN 6310-5	63	10	64.75	57.7	2×2.5	64.2	222.5	2100
BNFN 6310-7.5	63	10	64.75	57.7	3×2.5	90.9	334.2	3090
BNFN 6312A-2.5	63	12	65.25	56.3	1×2.5	48.1	139.2	1120
BNFN 6312A-5	63	12	65.25	56.3	2×2.5	87.4	278.3	2160
BNFN 6316-2.5	63	16	65.7	55.9	1×2.5	81.1	231.3	1470
BNFN 6316-5	63	16	65.7	55.9	2×2.5	147	462.6	2840
BNFN 6320-2.5	63	20	65.7	55.9	1×2.5	81	231.3	1470
BNFN 6320-5	63	20	65.7	55.9	2×2.5	147	463.5	2640

Note) The model numbers in dimmed type indicate semi-standard types.
If desiring them, contact THK.

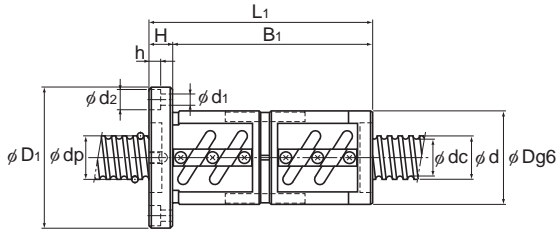

Unit: mm

	Nut dimensions							Screw shaft inertial moment/mm kg-cm ² /mm	Nut mass kg	Shaft mass kg/m
	Outer diameter D	Flange diameter D ₁	Overall length L ₁	H	B ₁	PCD	d ₁ × d ₂ × h			
102	144	141	18	123	122	11 × 17.5 × 11	R1/8 (PT1/8)	7.05 × 10 ⁻²	6.54	16.43
102	144	201	18	183	122	11 × 17.5 × 11	R1/8 (PT1/8)	7.05 × 10 ⁻²	8.88	16.43
102	144	261	18	243	122	11 × 17.5 × 11	R1/8 (PT1/8)	7.05 × 10 ⁻²	11.23	16.43
105	147	165	18	147	125	11 × 17.5 × 11	R1/8 (PT1/8)	7.05 × 10 ⁻²	8.07	16.29
105	147	191	18	173	125	11 × 17.5 × 11	R1/8 (PT1/8)	7.05 × 10 ⁻²	9.17	16.29
105	147	189	18	171	125	11 × 17.5 × 11	R1/8 (PT1/8)	7.05 × 10 ⁻²	9.09	16.29
105	147	237	18	219	125	11 × 17.5 × 11	R1/8 (PT1/8)	7.05 × 10 ⁻²	11.13	16.29
105	147	309	18	291	125	11 × 17.5 × 11	R1/8 (PT1/8)	7.05 × 10 ⁻²	14.19	16.29
110	158	196	25	171	133	14 × 20 × 13	R1/8 (PT1/8)	7.05 × 10 ⁻²	11.28	15.46
110	158	292	25	267	133	14 × 20 × 13	R1/8 (PT1/8)	7.05 × 10 ⁻²	15.94	15.46
112	158	227	28	199	134	14 × 20 × 13	R1/8 (PT1/8)	7.05 × 10 ⁻²	13.49	16.1
112	158	347	28	319	134	14 × 20 × 13	R1/8 (PT1/8)	7.05 × 10 ⁻²	19.61	16.1
108	154	137	22	115	130	14 × 20 × 13	R1/8 (PT1/8)	1.21 × 10 ⁻¹	6.98	21.93
108	154	197	22	175	130	14 × 20 × 13	R1/8 (PT1/8)	1.21 × 10 ⁻¹	9.4	21.93
108	154	257	22	235	130	14 × 20 × 13	R1/8 (PT1/8)	1.21 × 10 ⁻¹	11.81	21.93
115	161	159	22	137	137	14 × 20 × 13	R1/8 (PT1/8)	1.21 × 10 ⁻¹	9.32	21.14
115	161	231	22	209	137	14 × 20 × 13	R1/8 (PT1/8)	1.21 × 10 ⁻¹	12.84	21.14
122	184	208	24	184	152	18 × 26 × 17.5	R1/8 (PT1/8)	1.21 × 10 ⁻¹	14.61	20.85
122	184	304	24	280	152	18 × 26 × 17.5	R1/8 (PT1/8)	1.21 × 10 ⁻¹	20.19	20.85
122	180	227	28	199	150	18 × 26 × 17.5	R1/8 (PT1/8)	1.21 × 10 ⁻¹	15.91	20.85
122	180	347	28	319	150	18 × 26 × 17.5	R1/8 (PT1/8)	1.21 × 10 ⁻¹	22.88	20.85

Note) The overall length of the nut will increase when equipping the QZ lubricating device. See **A15-344** for further details.
For model number coding, see **A15-230**.

BNFN With Preload

DN value	70000
----------	-------

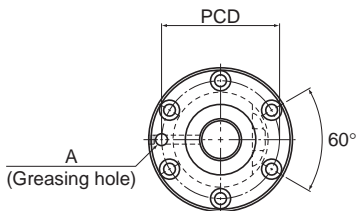

Model No.	Screw shaft outer diameter d	Lead Ph	Ball center-to-center diameter dp	Thread minor diameter dc	No. of loaded circuits Rows X turns	Basic load rating		Rigidity K N/μm
						Ca kN	C _{0a} kN	
BNFN 7010-2.5	70	10	71.75	64.5	1×2.5	36.8	123.5	1180
BNFN 7010-5	70	10	71.75	64.5	2×2.5	66.9	247	2280
BNFN 7010-7.5	70	10	71.75	64.5	3×2.5	94.9	371.4	3350
BNFN 7012-2.5	70	12	72	64.2	1×2.5	43.5	139.2	1200
BNFN 7012-5	70	12	72	64.2	2×2.5	78.9	278.3	2320
BNFN 7012-7.5	70	12	72	64.2	3×2.5	111.7	417.5	3420
BNFN 7020-5	70	20	72.7	62.9	2×2.5	153.9	514.5	3090
BNFN 8010-2.5	80	10	81.75	75.2	1×2.5	38.9	141.1	1300
BNFN 8010-5	80	10	81.75	75.2	2×2.5	70.6	283.2	2530
BNFN 8010-7.5	80	10	81.75	75.2	3×2.5	100	424.3	3720
BNFN 8012-5	80	12	82.3	74.1	2×2.5	96.5	353.8	2620
BNFN 8020A-2.5	80	20	82.7	72.9	1×2.5	90.1	294	1770
BNFN 8020A-5	80	20	82.7	72.9	2×2.5	163.7	589	3430
BNFN 10020A-2.5	100	20	102.7	92.9	1×2.5	99	368.5	2110
BNFN 10020A-5	100	20	102.7	92.9	2×2.5	179.3	737	4080
BNFN 10020A-7.5	100	20	102.7	92.9	3×2.5	253.8	1105.4	6010

Note) The model numbers in dimmed type indicate semi-standard types.
If desiring them, contact THK.

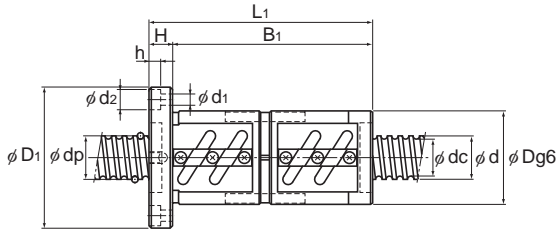

Unit: mm

	Nut dimensions							Screw shaft inertial moment/mm kg-cm ² /mm	Nut mass kg	Shaft mass kg/m	
	Outer diameter D	Flange diameter D ₁	Overall length L ₁	H	B ₁	PCD	d ₁ × d ₂ × h				Greasing hole A
	125	167	141	18	123	145	11 × 17.5 × 11	R1/8 (PT1/8)	1.85 × 10 ⁻¹	9.19	27.4
	125	167	201	18	183	145	11 × 17.5 × 11	R1/8 (PT1/8)	1.85 × 10 ⁻¹	12.57	27.4
	125	167	261	18	243	145	11 × 17.5 × 11	R1/8 (PT1/8)	1.85 × 10 ⁻¹	15.96	27.4
	128	170	165	18	147	148	11 × 17.5 × 11	R1/8 (PT1/8)	1.85 × 10 ⁻¹	11.26	27.24
	128	170	237	18	219	148	11 × 17.5 × 11	R1/8 (PT1/8)	1.85 × 10 ⁻¹	15.63	27.24
	128	170	309	18	291	148	11 × 17.5 × 11	R1/8 (PT1/8)	1.85 × 10 ⁻¹	20	27.24
	130	186	325	28	297	158	18 × 26 × 17.5	R1/8 (PT1/8)	1.85 × 10 ⁻¹	23.4	27
	130	176	137	22	115	152	14 × 20 × 13	R1/8 (PT1/8)	3.16 × 10 ⁻¹	9.15	36.26
	130	176	197	22	175	152	14 × 20 × 13	R1/8 (PT1/8)	3.16 × 10 ⁻¹	12.41	36.26
	130	176	257	22	235	152	14 × 20 × 13	R1/8 (PT1/8)	3.16 × 10 ⁻¹	15.67	36.26
	135	181	231	22	209	157	14 × 20 × 13	R1/8 (PT1/8)	3.16 × 10 ⁻¹	16.02	35.26
	143	204	227	28	199	172	18 × 26 × 17.5	R1/8 (PT1/8)	3.16 × 10 ⁻¹	20.08	35.81
	143	204	347	28	319	172	18 × 26 × 17.5	R1/8 (PT1/8)	3.16 × 10 ⁻¹	28.97	35.81
	170	243	231	32	199	205	22 × 32 × 21.5	R1/8 (PT1/8)	7.71 × 10 ⁻¹	28.15	57.13
	170	243	351	32	319	205	22 × 32 × 21.5	R1/8 (PT1/8)	7.71 × 10 ⁻¹	39.99	57.13
	170	243	471	32	439	205	22 × 32 × 21.5	R1/8 (PT1/8)	7.71 × 10 ⁻¹	51.84	57.13

Note) The overall length of the nut will increase when equipping the QZ lubricating device. See [A15-344](#) for further details.
For model number coding, see [A15-230](#).

DKN With Preload

DN value	70000
----------	-------

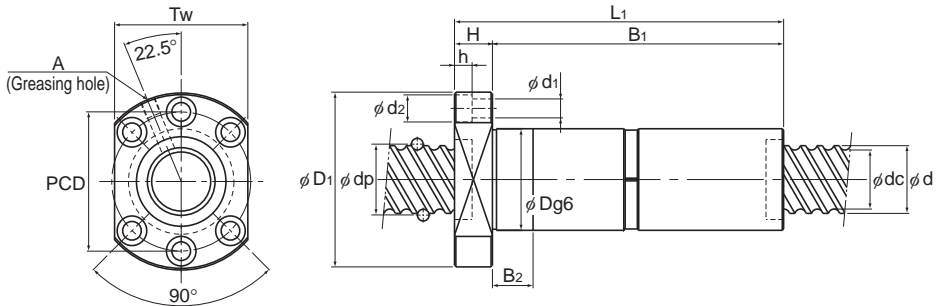

Unit: mm

Model No.	Screw shaft outer diameter d	Lead Ph	Ball center-to-center diameter dp	Thread minor diameter dc	No. of loaded circuits Rows X turns	Basic load rating		Rigidity K	Nut dimensions		
						Ca kN	C _{0a} kN		Outer diameter D	Flange diameter D ₁	Overall length L ₁
DKN 4020-3	40	20	41.75	34.7	3×1	29.4	69.3	750	62	104	223
DKN 5020-3	50	20	52.25	43.6	3×1	44.2	108.8	930	75	129	243
DKN 6320-3	63	20	65.7	55.9	3×1	83.5	229.3	1470	95	159	243

Model No.	Nut dimensions							Screw shaft inertial moment/mm kg-cm ² /mm	Nut mass kg	Shaft mass kg/m
	H	B ₁	B ₂	PCD	d ₁ × d ₂ × h	Tw	Greasing hole A			
DKN 4020-3	18	205	25	82	11 × 17.5 × 11	79	R1/8 (PT1/8)	1.97 × 10 ⁻²	3.61	9.03
DKN 5020-3	28	215	30	105	14 × 20 × 13	98	R1/8 (PT1/8)	4.82 × 10 ⁻²	6.0	13.8
DKN 6320-3	28	215	30	129	18 × 26 × 17.5	121	R1/8 (PT1/8)	1.21 × 10 ⁻²	9.5	20.85

Note) The overall length of the nut will increase when equipping the QZ lubricating device. See [A15-344](#) for further details.
For model number coding, see [A15-230](#).

BLW With Preload

DN value	70000
----------	-------

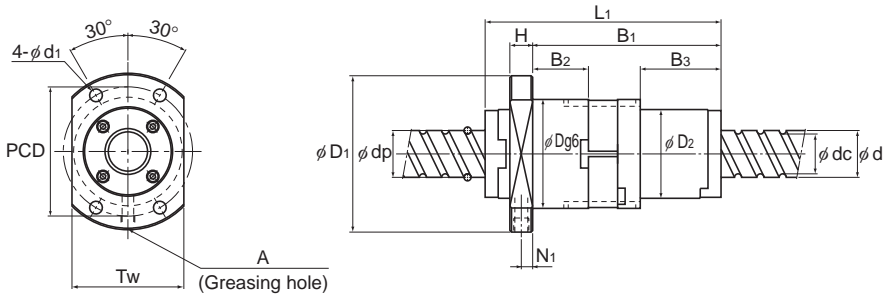

Unit: mm

Model No.	Screw shaft outer diameter d	Lead Ph	Ball center-to-center diameter dp	Thread minor diameter dc	No. of loaded circuits Rows X turns	Basic load rating		Rigidity K	Nut dimensions				
						Ca	C _{0a}		Outer diameter D	Flange diameter D ₁	D ₂	Overall length L ₁	H
						kN	kN	N/μm	D	D ₁	D ₂	L ₁	H
BLW 1510-3.6	15	10	15.75	12.5	2×2.8	14.3	27.8	680	43	64	34	89	10
BLW 1616-3.6	16	16	16.65	13.7	2×1.8	7.1	14.3	440	41	60	32	84.5	10
BLW 2020-3.6	20	20	20.75	17.5	2×1.8	11.1	24.7	570	48	69	39	105	10
BLW 2525-3.6	25	25	26	21.9	2×1.8	16.6	38.7	700	57	82	47	124.5	12
BLW 3232-3.6	32	32	33.25	28.3	2×1.8	23.7	59.5	880	68	99	58	155	15
BLW 3636-3.6	36	36	37.4	31.7	2×1.8	30.8	78	980	79	116	66	181	17
BLW 4040-3.6	40	40	41.75	35.2	2×1.8	38.7	99.2	1090	84	121	73	191	17
BLW 5050-3.6	50	50	52.2	44.1	2×1.8	57.8	155	1340	106	149	90	245	20

Model No.	Nut dimensions								Screw shaft inertial moment/mm kg-cm ² /mm	Nut mass kg	Shaft mass kg/m
	B ₁	B ₂	B ₃	PCD	d ₁	Tw	N ₁	Greasing hole A			
	B ₁	B ₂	B ₃	PCD	d ₁	Tw	N ₁	A			
BLW 1510-3.6	69	18.7	28.6	52	5.5	46	5	M6	3.9×10 ⁻⁴	0.81	1.07
BLW 1616-3.6	65.5	18.1	27.1	49	4.5	44	6	M6	5.05×10 ⁻⁴	0.67	1.42
BLW 2020-3.6	84	25	36	57	5.5	50	5	M6	1.23×10 ⁻³	0.54	2.25
BLW 2525-3.6	101.5	33	44	68	6.6	60	5	M6	3.01×10 ⁻³	0.94	3.52
BLW 3232-3.6	127	42.4	55.4	81	9	70	6	M6	8.08×10 ⁻³	3.19	5.83
BLW 3636-3.6	147.9	49.4	65.4	95	11	82	7	M6	1.29×10 ⁻²	5.99	7.34
BLW 4040-3.6	158	54.5	70.5	100	11	87	7	M6	1.97×10 ⁻²	6.16	9.01
BLW 5050-3.6	203.8	70.7	91.7	126	14	108	8	M6	4.82×10 ⁻²	9.06	14.08

Note) The overall length of the nut will increase when equipping the QZ lubricating device. See [A15-344](#) for further details.
For model number coding, see [A15-230](#).
Model BLW cannot be attached with seal.

BNF-V Small No Preload

DN value	100000
----------	--------

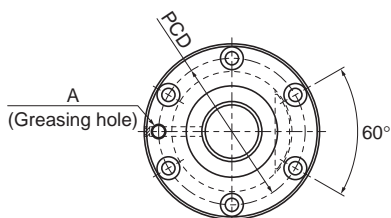

Model No.	Screw shaft outer diameter d	Lead Ph	Ball center-to-center diameter dp	Thread minor diameter dc	No. of loaded circuits Rows X turns	Basic load rating		Rigidity K N/μm
						Ca kN	C _{0a} kN	
BNF 1604V-5	16	4	16.5	13.8	2×2.5	7.8	17.4	290
BNF 1605V-2.5	16	5	16.75	13.2	1×2.5	7.4	13.9	170
BNF 1605V-5	16	5	16.75	13.2	2×2.5	13.5	27.9	320
BNF 2004V-2.5	20	4	20.5	17.8	1×2.5	4.8	10.9	180
BNF 2004V-5	20	4	20.5	17.8	2×2.5	8.6	21.8	350
BNF 2005V-2.5	20	5	20.75	17.2	1×2.5	8.3	17.5	200
BNF 2005V-5	20	5	20.75	17.2	2×2.5	15.1	35	380
BNF 2010V-2.5	20	10	20.75	17.2	1×2.5	8.3	17.6	197
BNF 2504V-2.5	25	4	25.5	22.8	1×2.5	5.2	13.7	210
BNF 2504V-5	25	4	25.5	22.8	2×2.5	9.5	27.4	410
BNF 2505V-2.5	25	5	25.75	22.2	1×2.5	9.2	21.9	240
BNF 2505V-5	25	5	25.75	22.2	2×2.5	16.7	43.9	460
BNF 2506V-2.5	25	6	26	21.4	1×2.5	12.4	27.4	250
BNF 2506V-5	25	6	26	21.4	2×2.5	22.6	54.8	470
BNF 2805V-2.5	28	5	28.75	25.2	1×2.5	9.7	24.6	250
BNF 2805V-5	28	5	28.75	25.2	2×2.5	17.5	49.2	500
BNF 2805V-7.5	28	5	28.75	25.2	3×2.5	24.8	73.8	740
BNF 2806V-2.5	28	6	28.75	25.2	1×2.5	9.6	24.6	250
BNF 2806V-5	28	6	28.75	25.2	2×2.5	17.5	49.2	500
BNF 2806V-7.5	28	6	28.75	25.2	3×2.5	24.8	73.8	740
BNF 3205V-2.5	32	5	32.75	29.2	1×2.5	10.2	28.1	280
BNF 3205V-5	32	5	32.75	29.2	2×2.5	18.5	56.3	560
BNF 3205V-7.5	32	5	32.75	29.2	3×2.5	26.2	84.4	810
BNF 3206V-2.5	32	6	33	28.4	1×2.5	13.9	35.2	290
BNF 3206V-5	32	6	33	28.4	2×2.5	25.2	70.3	580

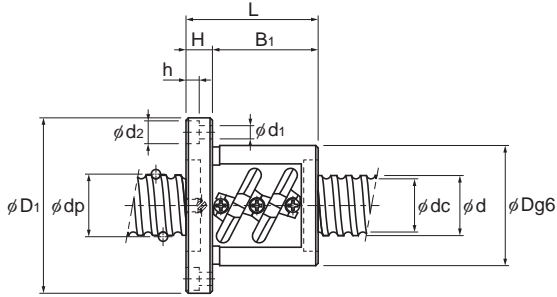

Unit: mm

	Nut dimensions								Screw shaft inertial moment/mm ³ kg-cm ² /mm	Nut mass kg	Shaft mass kg/m
	Outer diameter	Flange diameter	Overall length	H	B ₁	PCD	d ₁ × d ₂ × h	Greasing hole			
	D	D ₁	L ₁	H	B ₁	PCD	d ₁ × d ₂ × h	A			
	36	59	53	11	42	47	5.5 × 9.5 × 5.5	M6	5.05 × 10 ⁻⁴	0.42	1.42
	40	60	41	10	31	50	4.5 × 8 × 4.5	M6	5.05 × 10 ⁻⁴	0.37	1.37
	40	60	56	10	46	50	4.5 × 8 × 4.5	M6	5.05 × 10 ⁻⁴	0.49	1.37
	40	63	37	11	26	51	5.5 × 9.5 × 5.5	M6	1.23 × 10 ⁻³	0.3	2.22
	40	63	49	11	38	51	5.5 × 9.5 × 5.5	M6	1.23 × 10 ⁻³	0.49	2.22
	44	67	41	11	30	55	5.5 × 9.5 × 5.5	M6	1.23 × 10 ⁻³	0.46	2.19
	44	67	56	11	45	55	5.5 × 9.5 × 5.5	M6	1.23 × 10 ⁻³	0.6	2.19
	46	74	58	15	43	59	5.5 × 9.5 × 5.5	M6	1.23 × 10 ⁻³	0.68	2.46
	46	69	36	11	25	57	5.5 × 9.5 × 5.5	M6	3.01 × 10 ⁻³	0.21	3.6
	46	69	48	11	37	57	5.5 × 9.5 × 5.5	M6	3.01 × 10 ⁻³	0.55	3.6
	50	73	40	11	29	61	5.5 × 9.5 × 5.5	M6	3.01 × 10 ⁻³	0.52	3.52
	50	73	55	11	44	61	5.5 × 9.5 × 5.5	M6	3.01 × 10 ⁻³	0.68	3.52
	53	76	44	11	33	64	5.5 × 9.5 × 5.5	M6	3.01 × 10 ⁻³	0.61	3.43
	53	76	62	11	51	64	5.5 × 9.5 × 5.5	M6	3.01 × 10 ⁻³	0.91	3.43
	55	85	44	12	32	69	6.6 × 11 × 6.5	M6	4.74 × 10 ⁻³	1.02	4.45
	55	85	59	12	47	69	6.6 × 11 × 6.5	M6	4.74 × 10 ⁻³	1.06	4.45
	55	85	74	12	62	69	6.6 × 11 × 6.5	M6	4.74 × 10 ⁻³	1.16	4.45
	55	85	50	12	38	69	6.6 × 11 × 6.5	M6	4.74 × 10 ⁻³	0.87	4.52
	55	85	68	12	56	69	6.6 × 11 × 6.5	M6	4.74 × 10 ⁻³	1.09	4.52
	55	85	86	12	74	69	6.6 × 11 × 6.5	M6	4.74 × 10 ⁻³	1.3	4.52
	58	85	41	12	29	71	6.6 × 11 × 6.5	M6	8.08 × 10 ⁻³	0.76	5.89
	58	85	56	12	44	71	6.6 × 11 × 6.5	M6	8.08 × 10 ⁻³	0.94	5.89
	58	85	71	12	59	71	6.6 × 11 × 6.5	M6	8.08 × 10 ⁻³	1.13	5.89
	62	89	45	12	33	75	6.6 × 11 × 6.5	M6	8.08 × 10 ⁻³	0.94	5.88
	62	89	63	12	51	75	6.6 × 11 × 6.5	M6	8.08 × 10 ⁻³	1.21	5.88

Note) The overall length of the nut will increase when equipping the QZ lubricating device. See [A15-344](#) for further details.
For model number coding, see [A15-230](#).

BNF-V Medium No Preload

DN value	130000
----------	--------

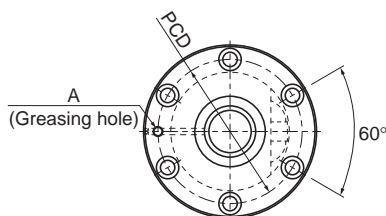

Model No.	Screw shaft outer diameter d	Lead Ph	Ball center-to-center diameter dp	Thread minor diameter dc	No. of loaded circuits Rows X turns	Basic load rating		Rigidity K N/μm
						Ca kN	C _{0a} kN	
BNF 2508V-2.5	25	8	26.25	20.5	1×2.5	15.8	32.9	250
BNF 2508V-3.5	25	8	26.25	20.5	1×3.5	21.1	46	340
BNF 2508V-5	25	8	26.25	20.5	2×2.5	28.7	65.7	480
BNF 2510V-2.5	25	10	26.25	21.5	1×2.5	15.8	32.9	250
BNF 2810V-2.5	28	10	29.75	22.4	1×2.5	24.3	49	280
BNF 3210V-2.5	32	10	33.75	26.4	1×2.5	26	56.2	310
BNF 3210V-3.5	32	10	33.75	26.4	1×3.5	34.8	78.6	440
BNF 3210V-5	32	10	33.75	26.4	2×2.5	47.3	112.3	620
BNF 3212V-3.5	32	12	34	26.1	1×3.5	40.4	88.5	440
BNF 3216V-5	32	16	33.75	26.4	2×2.5	47.1	113.1	616
BNF 3610V-2.5	36	10	37.75	30.5	1×2.5	27.6	63.3	350
BNF 3610V-5	36	10	37.75	30.5	2×2.5	50.1	126.5	680
BNF 3610V-7.5	36	10	37.75	30.5	3×2.5	71	189.8	990
BNF 3612V-2.5	36	12	38	30.1	1×2.5	32.2	71.2	350
BNF 3612V-5	36	12	38	30.1	2×2.5	58.4	142.3	690
BNF 3616V-2.5	36	16	38	30.1	1×2.5	32.1	71.5	350
BNF 3620V-1.5	36	20	37.75	30.5	1×1.5	17.7	38.4	215
BNF 4010V-2.5	40	10	41.75	34.4	1×2.5	29	70.4	380
BNF 4010V-3.5	40	10	41.75	34.4	1×3.5	38.8	98.5	520
BNF 4010V-5	40	10	41.75	34.4	2×2.5	52.7	140.7	740
BNF 4012V-2.5	40	12	42	34.1	1×2.5	33.9	79.2	390
BNF 4012V-3.5	40	12	42	34.1	1×3.5	45.3	110.8	530
BNF 4012V-5	40	12	42	34.1	2×2.5	61.6	158.3	750
BNF 4016V-5	40	16	42	34.1	2×2.5	61.5	158.8	740
BNF 4020V-5	40	20	41.75	34.4	2×2.5	52.4	142	736

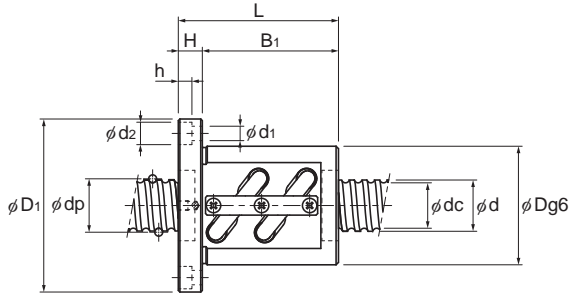

Unit: mm

	Nut dimensions								Screw shaft inertial moment/mm ³ kg-cm ² /mm	Nut mass kg	Shaft mass kg/m
	Outer diameter D	Flange diameter D ₁	Overall length L ₁	H	B ₁	PCD	d ₁ × d ₂ × h	Greasing hole A			
	58	85	58	15	43	71	6.6 × 11 × 6.5	M6	3.01 × 10 ⁻³	1.07	3.51
	58	85	66	15	51	71	6.6 × 11 × 6.5	M6	3.01 × 10 ⁻³	1.29	3.51
	58	85	82	15	67	71	6.6 × 11 × 6.5	M6	3.01 × 10 ⁻³	1.44	3.51
	58	85	70	18	52	71	6.6 × 11 × 6.5	M6	3.01 × 10 ⁻³	1.43	3.5
	65	106	86	18	68	85	11 × 17.5 × 11	M6	4.74 × 10 ⁻⁴	2.3	4.15
	74	108	70	15	55	90	9 × 14 × 8.5	M6	8.08 × 10 ⁻³	2.2	5.53
	74	108	80	15	65	90	9 × 14 × 8.5	M6	8.08 × 10 ⁻³	2.44	5.53
	74	108	100	15	85	90	9 × 14 × 8.5	M6	8.08 × 10 ⁻³	2.92	5.53
	76	121	98	18	80	98	11 × 17.5 × 11	M6	8.08 × 10 ⁻³	3.4	5.7
	74	108	139	18	121	90	9 × 14 × 8.5	M6	8.08 × 10 ⁻³	3.81	5.82
	75	120	81	18	63	98	11 × 17.5 × 11	M6	1.29 × 10 ⁻²	2.75	7.1
	75	120	111	18	93	98	11 × 17.5 × 11	M6	1.29 × 10 ⁻²	3.45	7.1
	75	120	141	18	123	98	11 × 17.5 × 11	M6	1.29 × 10 ⁻²	4.15	7.1
	78	123	87	18	69	100	11 × 17.5 × 11	M6	1.29 × 10 ⁻²	3.14	7.99
	78	123	123	18	105	100	11 × 17.5 × 11	M6	1.29 × 10 ⁻²	4.07	7.99
	78	123	92	18	74	100	11 × 17.5 × 11	M6	1.29 × 10 ⁻²	3.27	7.99
	75	114	82	18	64	93	11 × 17.5 × 11	M6	1.29 × 10 ⁻²	2.38	7.54
	82	124	73	18	55	102	11 × 17.5 × 11	M6	1.97 × 10 ⁻²	2.86	8.87
	82	124	83	18	65	102	11 × 17.5 × 11	M6	1.97 × 10 ⁻²	3.14	8.87
	82	124	103	18	85	102	11 × 17.5 × 11	M6	1.97 × 10 ⁻²	3.69	8.87
	84	126	83	18	65	104	11 × 17.5 × 11	M6	1.97 × 10 ⁻²	3.31	8.83
	84	126	95	18	77	104	11 × 17.5 × 11	M6	1.97 × 10 ⁻²	3.66	8.83
	84	126	119	18	101	104	11 × 17.5 × 11	M6	1.97 × 10 ⁻²	4.36	8.83
	84	126	144	18	126	104	11 × 17.5 × 11	M6	1.97 × 10 ⁻²	5.52	9.09
	82	126	162	18	144	104	11 × 17.5 × 11	M6	1.97 × 10 ⁻²	5.17	9.37

Note) The overall length of the nut will increase when equipping the QZ lubricating device. See [A15-344](#) for further details.
For model number coding, see [A15-230](#).

BNF-V Medium No Preload

DN value	130000
----------	--------

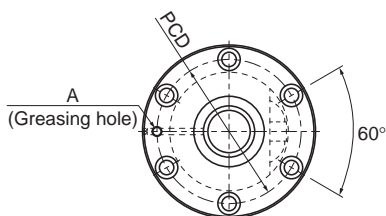

Model No.	Screw shaft outer diameter d	Lead Ph	Ball center-to-center diameter dp	Thread minor diameter dc	No. of loaded circuits Rows X turns	Basic load rating		Rigidity K N/μm
						Ca kN	C _a a kN	
BNF 4510V-2.5	45	10	46.75	39.5	1×2.5	30.6	79.3	420
BNF 4510V-3	45	10	46.75	39.5	2×1.5	35.8	95.1	500
BNF 4510V-5	45	10	46.75	39.5	2×2.5	55.6	158.5	800
BNF 4510V-7.5	45	10	46.75	39.5	3×2.5	78.8	237.8	1190
BNF 4512V-5	45	12	47	39.2	2×2.5	65.2	178.3	820
BNF 4520V-2.5	45	20	47	39.2	1×2.5	35.8	89.7	424
BNF 5010V-2.5	50	10	51.75	44.4	1×2.5	32.1	88.1	450
BNF 5010V-3.5	50	10	51.75	44.4	1×3.5	42.9	123.4	620
BNF 5010V-5	50	10	51.75	44.4	2×2.5	58.2	176.3	880
BNF 5010V-7.5	50	10	51.75	44.4	3×2.5	82.5	264.4	1290
BNF 5012V-2.5	50	12	52.25	43.3	1×2.5	43.4	110.1	470
BNF 5012V-3.5	50	12	52.25	43.3	1×3.5	58	154.1	640
BNF 5012V-5	50	12	52.25	43.3	2×2.5	78.8	220.2	910
BNF 5016V-2.5	50	16	52.7	42.9	1×2.5	72.6	183.1	620
BNF 5016V-5	50	16	52.7	42.9	2×2.5	131.8	366.2	1180
BNF 5020V-2.5	50	20	52.7	42.9	1×2.5	72.5	183.6	620

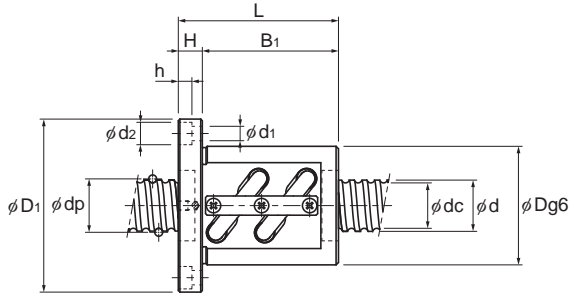

Unit: mm

	Nut dimensions								Screw shaft inertial moment/mm kg-cm ² /mm	Nut mass kg	Shaft mass kg/m
	Outer diameter D	Flange diameter D ₁	Overall length L ₁	H	B ₁	PCD	d ₁ × d ₂ × h	Greasing hole A			
	88	132	81	18	63	110	11 × 17.5 × 11	R1/8 (PT1/8)	3.16 × 10 ⁻²	3.43	11.36
	88	132	94	18	76	110	11 × 17.5 × 11	R1/8 (PT1/8)	3.16 × 10 ⁻²	3.83	11.36
	88	132	111	18	93	110	11 × 17.5 × 11	R1/8 (PT1/8)	3.16 × 10 ⁻²	4.35	11.36
	88	132	141	18	123	110	11 × 17.5 × 11	R1/8 (PT1/8)	3.16 × 10 ⁻²	5.26	11.36
	90	130	119	18	101	110	11 × 17.5 × 11	R1/8 (PT1/8)	3.16 × 10 ⁻²	4.74	11.32
	90	130	102	18	84	110	11 × 17.5 × 11	R1/8 (PT1/8)	3.16 × 10 ⁻²	4.28	11.1
	93	135	73	18	55	113	11 × 17.5 × 11	R1/8 (PT1/8)	4.82 × 10 ⁻²	3.33	14.16
	93	135	83	18	65	113	11 × 17.5 × 11	R1/8 (PT1/8)	4.82 × 10 ⁻²	3.66	14.16
	93	135	103	18	85	113	11 × 17.5 × 11	R1/8 (PT1/8)	4.82 × 10 ⁻²	4.31	14.16
	93	135	133	18	115	113	11 × 17.5 × 11	R1/8 (PT1/8)	4.82 × 10 ⁻²	5.28	14.16
	100	146	87	22	65	122	14 × 20 × 13	R1/8 (PT1/8)	4.82 × 10 ⁻²	4.57	13.82
	100	146	99	22	77	122	14 × 20 × 13	R1/8 (PT1/8)	4.82 × 10 ⁻²	5.05	13.82
	100	146	123	22	101	122	14 × 20 × 13	R1/8 (PT1/8)	4.82 × 10 ⁻²	6.02	13.82
	105	152	116	25	91	128	14 × 20 × 13	R1/8 (PT1/8)	4.82 × 10 ⁻²	6.98	13.71
	105	152	164	25	139	128	14 × 20 × 13	R1/8 (PT1/8)	4.82 × 10 ⁻²	9.18	13.71
	105	152	141	28	113	128	14 × 20 × 13	R1/8 (PT1/8)	4.82 × 10 ⁻²	8.32	14.05

Note) The overall length of the nut will increase when equipping the QZ lubricating device. See **A15-344** for further details.
For model number coding, see **A15-230**.

BNF No Preload

DN value	70000
----------	-------

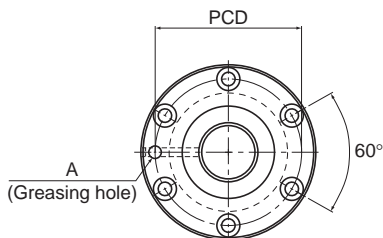

Model No.	Screw shaft outer diameter d	Lead Ph	Ball center-to-center diameter dp	Thread minor diameter dc	No. of loaded circuits Rows X turns	Basic load rating		Rigidity K N/μm
						Ca kN	C _{0a} kN	
BNF 5510-2.5	55	10	56.75	49.5	1×2.5	33.4	97	490
BNF 5510-5	55	10	56.75	49.5	2×2.5	60.7	194	950
BNF 5510-7.5	55	10	56.75	49.5	3×2.5	85.9	291.1	1390
BNF 5512-2.5	55	12	57	49.2	1×2.5	39.3	108.8	500
BNF 5512-3	55	12	57	49.2	2×1.5	46	131.3	590
BNF 5512-3.5	55	12	57	49.2	1×3.5	52.4	152.9	680
BNF 5512-5	55	12	57	49.2	2×2.5	71.3	218.5	960
BNF 5512-7.5	55	12	57	49.2	3×2.5	100.9	327.3	1420
BNF 5516-2.5	55	16	57.7	47.9	1×2.5	76.1	201.9	650
BNF 5516-5	55	16	57.7	47.9	2×2.5	138.2	402.8	1280
BNF 5520-2.5	55	20	57.7	47.9	1×2.5	76	201.9	660
BNF 5520-5	55	20	57.7	47.9	2×2.5	138.2	403.8	1280
BNF 6310-2.5	63	10	64.75	57.7	1×2.5	35.4	111.7	550
BNF 6310-5	63	10	64.75	57.7	2×2.5	64.2	222.5	1050
BNF 6310-7.5	63	10	64.75	57.7	3×2.5	90.9	334.2	1550
BNF 6312A-2.5	63	12	65.25	56.3	1×2.5	48.1	139.2	560
BNF 6312A-5	63	12	65.25	56.3	2×2.5	87.4	278.3	1090
BNF 6316-5	63	16	65.7	55.9	2×2.5	147	462.6	1420
BNF 6320-2.5	63	20	65.7	55.9	1×2.5	81	231.3	740
BNF 6310-5	63	20	65.7	55.9	2×2.5	147	463.5	1420

Note) The model numbers in dimmed type indicate semi-standard types.
If desiring them, contact THK.

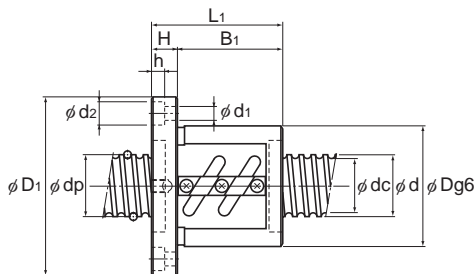

Unit: mm

	Nut dimensions								Screw shaft inertial moment/mm ² kg-cm ² /mm	Nut mass kg	Shaft mass kg/m
	Outer diameter D	Flange diameter D ₁	Overall length L ₁	H	B ₁	PCD	d ₁ × d ₂ × h	Greasing hole A			
102	144	81	18	63	122	11 × 17.5 × 11	R1/8 (PT1/8)	7.05 × 10 ⁻²	4.19	16.43	
102	144	111	18	93	122	11 × 17.5 × 11	R1/8 (PT1/8)	7.05 × 10 ⁻²	5.36	16.43	
102	144	141	18	123	122	11 × 17.5 × 11	R1/8 (PT1/8)	7.05 × 10 ⁻²	6.54	16.43	
105	147	93	18	75	125	11 × 17.5 × 11	R1/8 (PT1/8)	7.05 × 10 ⁻²	5.01	16.29	
105	147	107	18	89	125	11 × 17.5 × 11	R1/8 (PT1/8)	7.05 × 10 ⁻²	5.6	16.29	
105	147	105	18	87	125	11 × 17.5 × 11	R1/8 (PT1/8)	7.05 × 10 ⁻²	5.52	16.29	
105	147	129	18	111	125	11 × 17.5 × 11	R1/8 (PT1/8)	7.05 × 10 ⁻²	6.54	16.29	
105	147	165	18	147	125	11 × 17.5 × 11	R1/8 (PT1/8)	7.05 × 10 ⁻²	8.07	16.29	
110	158	116	25	91	133	14 × 20 × 13	R1/8 (PT1/8)	7.05 × 10 ⁻²	7.4	15.46	
110	158	164	25	139	133	14 × 20 × 13	R1/8 (PT1/8)	7.05 × 10 ⁻²	9.73	15.46	
112	158	127	28	99	134	14 × 20 × 13	R1/8 (PT1/8)	7.05 × 10 ⁻²	8.4	16.1	
112	158	187	28	159	134	14 × 20 × 13	R1/8 (PT1/8)	7.05 × 10 ⁻²	11.45	16.1	
108	154	77	22	55	130	14 × 20 × 13	R1/8 (PT1/8)	1.21 × 10 ⁻¹	4.57	21.93	
108	154	107	22	85	130	14 × 20 × 13	R1/8 (PT1/8)	1.21 × 10 ⁻¹	5.77	21.93	
108	154	137	22	115	130	14 × 20 × 13	R1/8 (PT1/8)	1.21 × 10 ⁻¹	6.98	21.93	
115	161	87	22	65	137	14 × 20 × 13	R1/8 (PT1/8)	1.21 × 10 ⁻¹	5.8	21.14	
115	161	123	22	101	137	14 × 20 × 13	R1/8 (PT1/8)	1.21 × 10 ⁻¹	7.56	21.14	
122	184	160	24	136	152	18 × 26 × 17.5	R1/8 (PT1/8)	1.21 × 10 ⁻¹	11.82	20.85	
122	180	127	28	99	150	18 × 26 × 17.5	R1/8 (PT1/8)	1.21 × 10 ⁻¹	10.1	21.57	
122	180	187	28	159	150	18 × 26 × 17.5	R1/8 (PT1/8)	1.21 × 10 ⁻¹	13.58	21.57	

Note) The overall length of the nut will increase when equipping the QZ lubricating device. See [A15-344](#) for further details.
For model number coding, see [A15-230](#).

BNF No Preload

DN value	7000
----------	------

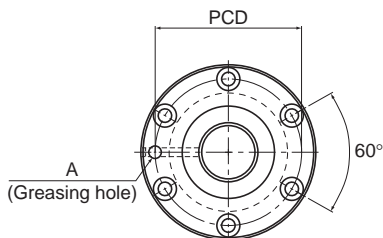

Model No.	Screw shaft outer diameter d	Lead Ph	Ball center-to-center diameter dp	Thread minor diameter dc	No. of loaded circuits Rows X turns	Basic load rating		Rigidity K N/μm
						Ca kN	C _{0a} kN	
BNF 7010-2.5	70	10	71.75	64.5	1×2.5	36.8	123.5	590
BNF 7010-5	70	10	71.75	64.5	2×2.5	66.9	247	1140
BNF 7010-7.5	70	10	71.75	64.5	3×2.5	94.9	371.4	1680
BNF 7012-2.5	70	12	72	64.2	1×2.5	43.5	139.2	600
BNF 7012-5	70	12	72	64.2	2×2.5	78.9	278.3	1160
BNF 7012-7.5	70	12	72	64.2	3×2.5	111.7	417.5	1710
BNF 7020-5	70	20	72.7	62.9	2×2.5	153.9	514.5	1550
BNF 8010-2.5	80	10	81.75	75.2	1×2.5	38.9	141.1	650
BNF 8010-5	80	10	81.75	75.2	2×2.5	70.6	283.2	1270
BNF 8010-7.5	80	10	81.75	75.2	3×2.5	100	424.3	1860
BNF 8020A-2.5	80	20	82.7	72.9	1×2.5	90.1	294	890
BNF 8020A-5	80	20	82.7	72.9	2×2.5	163.7	589	1720
BNF 8020A-7.5	80	20	82.7	72.9	3×2.5	231.6	883.2	2520
BNF 10020A-2.5	100	20	102.7	92.9	1×2.5	99	368.5	2110
BNF 10020A-5	100	20	102.7	92.9	2×2.5	179.3	737	4080
BNF 10020A-7.5	100	20	102.7	92.9	3×2.5	253.8	1105.4	6010

Note) The model numbers in dimmed type indicate semi-standard types.
If desiring them, contact THK.

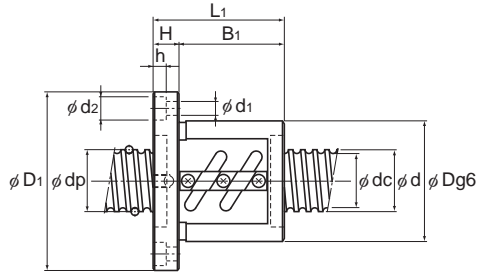

Unit: mm

	Nut dimensions								Screw shaft inertial moment/mm ² kg-cm ² /mm	Nut mass kg	Shaft mass kg/m
	Outer diameter D	Flange diameter D ₁	Overall length L ₁	H	B ₁	PCD	d ₁ × d ₂ × h	Greasing hole A			
	125	167	81	18	63	145	11 × 17.5 × 11	R1/8 (PT1/8)	1.85 × 10 ⁻¹	5.8	27.4
	125	167	111	18	93	145	11 × 17.5 × 11	R1/8 (PT1/8)	1.85 × 10 ⁻¹	7.49	27.4
	125	167	141	18	123	145	11 × 17.5 × 11	R1/8 (PT1/8)	1.85 × 10 ⁻¹	9.19	27.4
	128	170	93	18	75	148	11 × 17.5 × 11	R1/8 (PT1/8)	1.85 × 10 ⁻¹	6.89	27.24
	128	170	129	18	111	148	11 × 17.5 × 11	R1/8 (PT1/8)	1.85 × 10 ⁻¹	9.08	27.24
	128	170	165	18	147	148	11 × 17.5 × 11	R1/8 (PT1/8)	1.85 × 10 ⁻¹	11.26	27.24
	130	186	185	28	157	158	18 × 26 × 17.5	R1/8 (PT1/8)	1.85 × 10 ⁻¹	14.5	27
	130	176	77	22	55	152	14 × 20 × 13	R1/8 (PT1/8)	3.16 × 10 ⁻¹	5.9	36.26
	130	176	107	22	85	152	14 × 20 × 13	R1/8 (PT1/8)	3.16 × 10 ⁻¹	7.53	36.26
	130	176	137	22	115	152	14 × 20 × 13	R1/8 (PT1/8)	3.16 × 10 ⁻¹	9.15	36.26
	143	204	127	28	99	172	18 × 26 × 17.5	R1/8 (PT1/8)	3.16 × 10 ⁻¹	12.68	35.81
	143	204	187	28	159	172	18 × 26 × 17.5	R1/8 (PT1/8)	3.16 × 10 ⁻¹	17.12	35.81
	143	204	247	28	219	172	18 × 26 × 17.5	R1/8 (PT1/8)	3.16 × 10 ⁻¹	21.56	35.81
	170	243	131	32	99	205	22 × 32 × 21.5	R1/8 (PT1/8)	7.71 × 10 ⁻¹	18.28	57.13
	170	243	191	32	159	205	22 × 32 × 21.5	R1/8 (PT1/8)	7.71 × 10 ⁻¹	24.2	57.13
	170	243	251	32	219	205	22 × 32 × 21.5	R1/8 (PT1/8)	7.71 × 10 ⁻¹	30.12	57.13

Note) The overall length of the nut will increase when equipping the QZ lubricating device. See [A15-344](#) for further details.
For model number coding, see [A15-230](#).

DK No Preload

DN value	70000
----------	-------

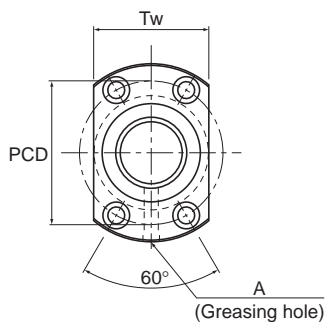

Model No.	Screw shaft outer diameter d	Lead Ph	Ball center-to-center diameter dp	Thread minor diameter dc	No. of loaded circuits Rows × turns	Basic load rating		Rigidity K N/μm
						Ca kN	C _{0a} kN	
DK 1404-4	14	4	14.5	11.8	4×1	5.4	10.2	180
DK 1404-6	14	4	14.5	11.8	6×1	7.7	15.4	270
DK 1605-3	16	5	16.75	13.1	3×1	7.4	13	160
DK 1605-4	16	5	16.75	13.1	4×1	9.5	17.4	210
DK 2004-3	20	4	20.5	17.8	3×1	5.2	11.6	190
DK 2004-4	20	4	20.5	17.8	4×1	6.6	15.5	250
DK 2005-3	20	5	20.75	17.1	3×1	8.5	17.3	200
DK 2005-4	20	5	20.75	17.1	4×1	11	23.1	260
DK 2006-3	20	6	21	16.4	3×1	11.4	21.5	410
DK 2006-4	20	6	21	16.4	4×1	14.6	28.6	540
DK 2008-4	20	8	21	16.4	4×1	14.6	28.8	270

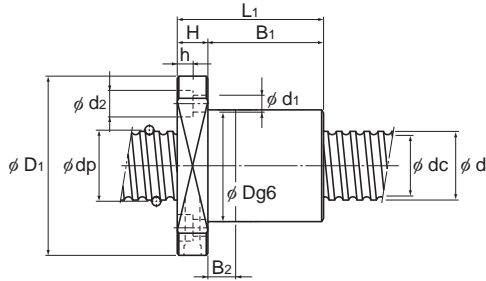

Unit: mm

	Nut dimensions										Screw shaft inertial moment/mm kg-cm ² /mm	Nut mass kg	Shaft mass kg/m
	Outer diameter	Flange diameter	Overall length							Greasing hole			
	D	D ₁	L ₁	H	B ₁	B ₂	PCD	d ₁ × d ₂ × h	Tw	A			
	26	45	48	10	38	10	35	4.5 × 8 × 4.5	29	M6	2.96 × 10 ⁻⁴	0.2	1
	26	45	60	10	50	10	35	4.5 × 8 × 4.5	29	M6	2.96 × 10 ⁻⁴	0.23	1
	30	49	45	10	35	10	39	4.5 × 8 × 4.5	31	M6	5.05 × 10 ⁻⁴	0.24	1.25
	30	49	50	10	40	10	39	4.5 × 8 × 4.5	31	M6	5.05 × 10 ⁻⁴	0.26	1.25
	32	56	42	11	31	10	44	5.5 × 9.5 × 5.5	35	M6	1.23 × 10 ⁻³	0.26	2.18
	32	56	46	11	35	10	44	5.5 × 9.5 × 5.5	35	M6	1.23 × 10 ⁻³	0.27	2.18
	34	58	46	11	35	10	46	5.5 × 9.5 × 5.5	36	M6	1.23 × 10 ⁻³	0.31	2.06
	34	58	51	11	40	10	46	5.5 × 9.5 × 5.5	36	M6	1.23 × 10 ⁻³	0.34	2.06
	35	58	52	11	41	10	46	5.5 × 9.5 × 5.5	36	M6	1.23 × 10 ⁻³	0.36	1.93
	35	58	59	11	48	10	46	5.5 × 9.5 × 5.5	36	M6	1.23 × 10 ⁻³	0.39	1.93
	35	58	69	11	58	15	46	5.5 × 9.5 × 5.5	36	M6	1.23 × 10 ⁻³	0.45	2.06

Note) The overall length of the nut will increase when equipping the QZ lubricating device. See **A15-344** for further details.
For model number coding, see **A15-230**.

DK No Preload

DN value	70000
----------	-------

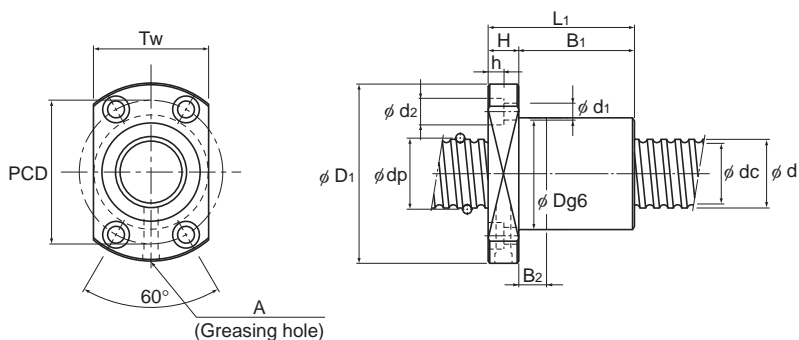

DK2504/2505/2506/2508/2510

Model No.	Screw shaft outer diameter d	Lead Ph	Ball center-to-center diameter dp	Thread minor diameter dc	No. of loaded circuits Rows X turns	Basic load rating		Rigidity K N/μm
						Ca kN	Ca kN	
DK 2504-3	25	4	25.5	22.8	3×1	5.7	15	230
DK 2504-4	25	4	25.5	22.8	4×1	7.4	19.9	310
DK 2505-3	25	5	25.75	22.1	3×1	9.7	22.6	250
DK 2505-4	25	5	25.75	22.1	4×1	12.4	30.3	320
DK 2506-3	25	6	26	21.4	3×1	12.8	27	250
DK 2506-4	25	6	26	21.4	4×1	16.8	37.4	330
DK 2508-3	25	8	26	21.4	3×1	13.1	28.1	500
DK 2508-4	25	8	26	21.4	4×1	16.8	37.5	330
DK 2510-3	25	10	26	21.6	3×1	12.7	27	250
DK 2510-4	25	10	26	21.6	4×1	16.7	37.6	330
DK 2805-3	28	5	28.75	25.2	3×1	10.5	26.4	270
DK 2805-4	28	5	28.75	25.2	4×1	13.4	35.2	360
DK 2806-3	28	6	29	24.4	3×1	14	32	280
DK 2806-4	28	6	29	24.4	4×1	18	42.5	370
DK 2810-4	28	10	29.25	23.6	4×1	22.4	50	370

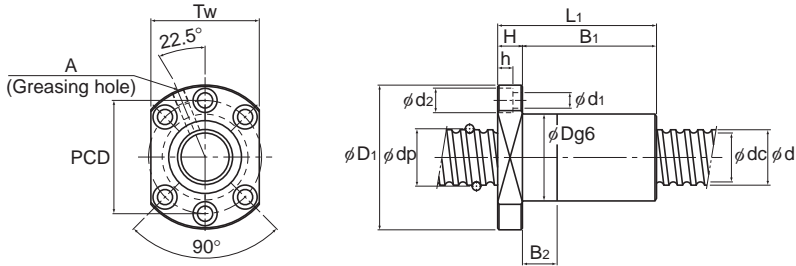

DK2805/2806/2810

Unit: mm

	Nut dimensions										Screw shaft inertial moment/mm ³	Nut mass kg	Shaft mass kg/m
	Outer diameter D	Flange diameter D ₁	Overall length L ₁	H	B ₁	B ₂	PCD	d ₁ × d ₂ × h	Tw	Greasing hole A			
	38	63	43	11	32	10	51	5.5 × 9.5 × 5.5	39	M6	3.01 × 10 ⁻³	0.33	3.5
	38	63	47	11	36	10	51	5.5 × 9.5 × 5.5	39	M6	3.01 × 10 ⁻³	0.35	3.5
	40	63	46	11	35	10	51	5.5 × 9.5 × 5.5	41	M6	3.01 × 10 ⁻³	0.38	3.35
	40	63	51	11	40	10	51	5.5 × 9.5 × 5.5	41	M6	3.01 × 10 ⁻³	0.41	3.35
	40	63	52	11	41	10	51	5.5 × 9.5 × 5.5	41	M6	3.01 × 10 ⁻³	0.41	3.19
	40	63	60	11	49	10	51	5.5 × 9.5 × 5.5	41	M6	3.01 × 10 ⁻³	0.46	3.19
	40	63	62	12	50	10	51	5.5 × 9.5 × 5.5	41	M6	3.01 × 10 ⁻³	0.48	3.35
	40	63	71	12	59	15	51	5.5 × 9.5 × 5.5	41	M6	3.01 × 10 ⁻³	0.54	3.35
	40	63	80	15	65	15	51	5.5 × 9.5 × 5.5	41	M6	3.01 × 10 ⁻³	0.62	3.45
	40	63	85	15	70	20	51	5.5 × 9.5 × 5.5	41	M6	3.01 × 10 ⁻³	0.65	3.45
	43	71	49	12	37	10	57	6.6 × 11 × 6.5	55	M6	4.74 × 10 ⁻³	0.48	4.27
	43	71	54	12	42	10	57	6.6 × 11 × 6.5	55	M6	4.74 × 10 ⁻³	0.51	4.27
	43	71	53	12	41	10	57	6.6 × 11 × 6.5	55	M6	4.74 × 10 ⁻³	0.5	4.36
	43	71	61	12	49	10	57	6.6 × 11 × 6.5	55	M6	4.74 × 10 ⁻³	0.56	4.36
	45	71	84	15	69	20	57	6.6 × 11 × 6.5	55	M6	4.74 × 10 ⁻³	0.82	4.18

Note) The overall length of the nut will increase when equipping the QZ lubricating device. See [A15-344](#) for further details.
For model number coding, see [A15-230](#).

DK No Preload

DN value	70000
----------	-------

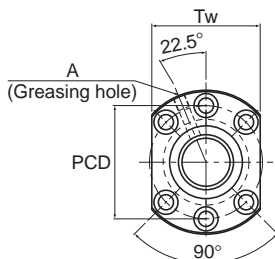

Model No.	Screw shaft outer diameter d	Lead Ph	Ball center-to-center diameter dp	Thread minor diameter dc	No. of loaded circuits Rows X turns	Basic load rating		Rigidity K N/μm
						Ca kN	C _{0a} kN	
DK 3204-3	32	4	32.5	30.1	3 × 1	6.4	19.6	290
DK 3204-4	32	4	32.5	30.1	4 × 1	8.2	26.1	380
DK 3205-3	32	5	32.75	29.2	3 × 1	11.1	30.2	300
DK 3205-4	32	5	32.75	29.2	4 × 1	14.2	40.3	400
DK 3205-6	32	5	32.75	29.2	6 × 1	20.1	60.4	600
DK 3206-3	32	6	33	28.4	3 × 1	14.9	37.1	310
DK 3206-4	32	6	33	28.4	4 × 1	19.1	49.5	410
DK 3210-3	32	10	33.75	26.4	3 × 1	25.7	52.2	300
DK 3210-4	32	10	33.75	26.4	4 × 1	33	69.7	390
DK 3212-4	32	12	33.75	26.4	4 × 1	34.2	73.9	420
DK 3610-3	36	10	37.75	30.5	3 × 1	28.8	63.8	350
DK 3610-4	36	10	37.75	30.5	4 × 1	36.8	85	470
DK 4010-3	40	10	41.75	34.4	3 × 1	29.8	69.3	380
DK 4010-4	40	10	41.75	34.4	4 × 1	38.1	92.4	500
DK 4012-3	40	12	41.75	34.4	3 × 1	30.6	72.3	390
DK 4012-4	40	12	41.75	34.4	4 × 1	39.2	96.4	520
DK 4016-4	40	16	41.75	34.4	4 × 1	39.1	96.8	520
DK 4020-3	40	20	41.75	34.7	3 × 1	29.4	69.3	750

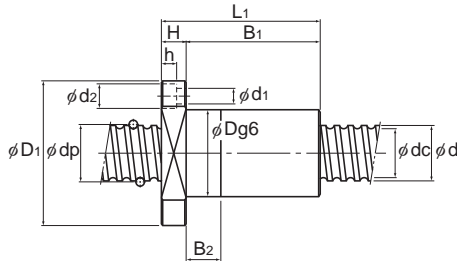

Unit: mm

	Nut dimensions										Screw shaft inertial moment/mm ³ kg-cm ² /mm	Nut mass kg	Shaft mass kg/m
	Outer diameter	Flange diameter	Overall length							Greasing hole			
	D	D ₁	L ₁	H	B ₁	B ₂	PCD	d ₁ × d ₂ × h	Tw	A			
	45	76	44	11	33	10	63	6.6 × 11 × 6.5	59	M6	8.08 × 10 ⁻³	0.44	5.86
	45	76	48	11	37	10	63	6.6 × 11 × 6.5	59	M6	8.08 × 10 ⁻³	0.47	5.86
	46	76	47	12	35	10	63	6.6 × 11 × 6.5	59	M6	8.08 × 10 ⁻³	0.5	5.67
	46	76	52	12	40	10	63	6.6 × 11 × 6.5	59	M6	8.08 × 10 ⁻³	0.53	5.67
	46	76	62	12	50	10	63	6.6 × 11 × 6.5	59	M6	8.08 × 10 ⁻³	0.6	5.67
	48	76	53	12	41	10	63	6.6 × 11 × 6.5	59	M6	8.08 × 10 ⁻³	0.58	6.31
	48	76	61	12	49	10	63	6.6 × 11 × 6.5	59	M6	8.08 × 10 ⁻³	0.65	6.31
	54	87	80	15	65	15	69	9 × 14 × 8.5	66	M6	8.08 × 10 ⁻³	1.22	4.98
	54	87	90	15	75	20	69	9 × 14 × 8.5	66	M6	8.08 × 10 ⁻³	1.34	4.98
	54	87	98	15	83	25	69	9 × 14 × 8.5	66	M6	8.08 × 10 ⁻³	1.43	5.2
	58	98	82	18	64	15	77	11 × 17.5 × 11	75	M6	1.29 × 10 ⁻²	1.52	6.51
	58	98	93	18	75	20	77	11 × 17.5 × 11	75	M6	1.29 × 10 ⁻²	1.66	6.51
	62	104	83	18	65	15	82	11 × 17.5 × 11	79	R1/8 (PT1/8)	1.97 × 10 ⁻²	3.14	8.22
	62	104	93	18	75	20	82	11 × 17.5 × 11	79	R1/8 (PT1/8)	1.97 × 10 ⁻²	3.41	8.22
	62	104	90	18	72	20	82	11 × 17.5 × 11	79	R1/8 (PT1/8)	1.97 × 10 ⁻²	1.77	8.5
	62	104	103	18	85	25	82	11 × 17.5 × 11	79	R1/8 (PT1/8)	1.97 × 10 ⁻²	1.95	8.5
	62	104	120	18	102	30	82	11 × 17.5 × 11	79	R1/8 (PT1/8)	1.97 × 10 ⁻²	2.19	8.83
	62	104	123	18	105	30	82	11 × 17.5 × 11	79	R1/8 (PT1/8)	1.97 × 10 ⁻²	2.23	9.03

Note) The overall length of the nut will increase when equipping the QZ lubricating device. See **A15-344** for further details.
For model number coding, see **A15-230**.

DK No Preload

DN value	70000
----------	-------

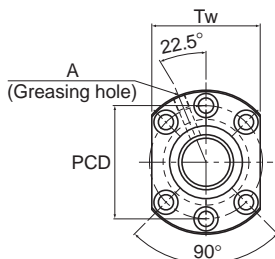

Model No.	Screw shaft outer diameter d	Lead Ph	Ball center-to-center diameter dp	Thread minor diameter dc	No. of loaded circuits Rows X turns	Basic load rating		Rigidity K N/μm
						Ca kN	C _{0a} kN	
DK 5010-3	50	10	51.75	44.4	3×1	33.9	90.7	470
DK 5010-4	50	10	51.75	44.4	4×1	43.4	120.5	610
DK 5010-6	50	10	51.75	44.4	6×1	62.7	186.8	930
DK 5012-3	50	12	52.25	43.3	3×1	45.8	113	490
DK 5012-4	50	12	52.25	43.3	4×1	58.6	150.6	640
DK 5016-3	50	16	52.25	43.3	3×1	45.7	113.3	490
DK 5016-4	50	16	52.25	43.3	4×1	58.5	151	640
DK 5020-3	50	20	52.25	43.6	3×1	44.2	108.8	470
DK 6310-4	63	10	64.75	57.7	4×1	49.5	160.7	780
DK 6310-6	63	10	64.75	57.7	6×1	70.3	242.1	1140
DK 6312-3	63	12	65.25	56.3	3×1	51.9	147.4	600
DK 6312-4	63	12	65.25	56.3	4×1	66.4	196.6	785
DK 6320-3	63	20	65.7	55.9	3×1	83.5	229.3	1470

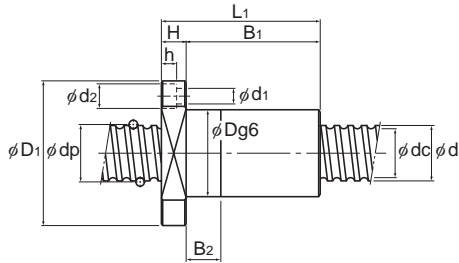

Unit: mm

	Nut dimensions										Screw shaft inertial moment/mm	Nut mass	Shaft mass
	Outer diameter	Flange diameter	Overall length	H	B ₁	B ₂	PCD	d ₁ × d ₂ × h	Tw	Greasing hole			
	D	D ₁	L ₁	H	B ₁	B ₂	PCD	d ₁ × d ₂ × h	Tw	A			
	72	123	83	18	65	15	101	11 × 17.5 × 11	92	R1/8 (PT1/8)	4.82 × 10 ⁻²	2.14	13.38
	72	123	93	18	75	20	101	11 × 17.5 × 11	92	R1/8 (PT1/8)	4.82 × 10 ⁻²	2.3	13.38
	72	123	114	18	96	30	101	11 × 17.5 × 11	92	R1/8 (PT1/8)	4.82 × 10 ⁻²	2.65	13.38
	75	129	97	22	75	20	105	14 × 20 × 13	98	R1/8 (PT1/8)	4.82 × 10 ⁻²	2.91	12.74
	75	129	110	22	88	25	105	14 × 20 × 13	98	R1/8 (PT1/8)	4.82 × 10 ⁻²	3.16	12.74
	75	129	111	22	89	25	105	14 × 20 × 13	98	R1/8 (PT1/8)	4.82 × 10 ⁻²	3.18	13.41
	75	129	129	22	107	30	105	14 × 20 × 13	98	R1/8 (PT1/8)	4.82 × 10 ⁻²	3.52	13.41
	75	129	136	28	108	30	105	14 × 20 × 13	98	R1/8 (PT1/8)	4.82 × 10 ⁻²	3.94	13.8
	85	146	97	22	75	20	122	14 × 20 × 13	110	R1/8 (PT1/8)	1.21 × 10 ⁻¹	3.28	21.93
	85	146	118	22	96	30	122	14 × 20 × 13	110	R1/8 (PT1/8)	1.21 × 10 ⁻¹	3.7	21.93
	90	146	98	22	76	20	122	14 × 20 × 13	110	R1/8 (PT1/8)	1.21 × 10 ⁻¹	3.71	21.14
	90	146	111	22	89	25	122	14 × 20 × 13	110	R1/8 (PT1/8)	1.21 × 10 ⁻¹	4.04	21.14
	95	159	136	28	108	30	129	18 × 26 × 17.5	121	R1/8 (PT1/8)	1.21 × 10 ⁻¹	6.17	21.57

Note) The overall length of the nut will increase when equipping the QZ lubricating device. See **A15-344** for further details.
For model number coding, see **A15-230**.

MDK No Preload

DN value	70000
----------	-------

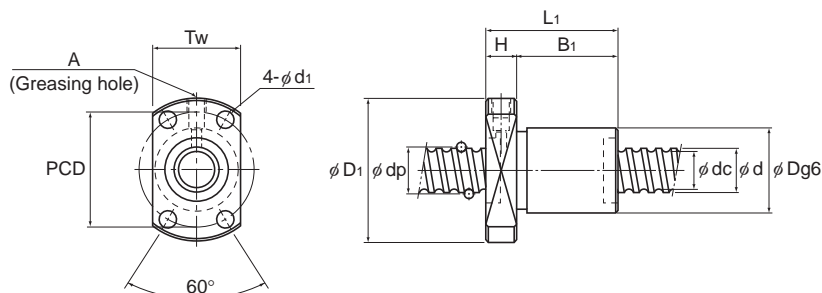

Unit: mm

Model No.	Screw shaft outer diameter	Lead	Ball center-to-center diameter	Thread minor diameter	No. of loaded circuits	Basic load rating		Rigidity	Nut dimensions		
						Ca	C _{0a}		K	Outer diameter	Flange diameter
						kN	kN	N/ μ m			
MDK 0401-3	4	1	4.15	3.4	3×1	0.29	0.42	35	9	19	13
MDK 0601-3	6	1	6.2	5.3	3×1	0.54	0.94	60	11	23	14.5
MDK 0801-3	8	1	8.2	7.3	3×1	0.64	1.4	80	13	26	15
MDK 0802-3	8	2	8.3	7	3×1	1.4	2.3	80	15	28	22
MDK 1002-3	10	2	10.3	9	3×1	1.5	2.9	100	17	34	22
MDK 1202-3	12	2	12.3	11	3×1	1.7	3.6	120	19	36	22
MDK 1402-3	14	2	14.3	13	3×1	1.8	4.3	190	21	40	23
MDK 1404-3	14	4	14.65	12.2	3×1	4.2	7.6	190	26	45	33
MDK 1405-3	14	5	14.75	11.2	3×1	7	11.6	140	26	45	42

Model No.	Nut dimensions						Screw shaft inertial moment/mm	Nut mass	Shaft mass
	H	B ₁	PCD	d _i	T _w	Greasing hole A			
MDK 0401-3	3	10	14	2.9	13	—	1.97×10 ⁻⁶	0.01	0.07
MDK 0601-3	3.5	11	17	3.4	15	—	9.99×10 ⁻⁶	0.017	0.14
MDK 0801-3	4	11	20	3.4	17	—	3.16×10 ⁻⁵	0.024	0.29
MDK 0802-3	5	17	22	3.4	19	—	3.16×10 ⁻⁵	0.034	0.27
MDK 1002-3	5	17	26	4.5	21	—	7.71×10 ⁻⁵	0.045	0.47
MDK 1202-3	5	17	28	4.5	23	—	1.6×10 ⁻⁴	0.05	0.71
MDK 1402-3	6	17	31	5.5	26	—	2.96×10 ⁻⁴	0.15	1
MDK 1404-3	6	27	36	5.5	28	—	2.96×10 ⁻⁴	0.13	0.8
MDK 1405-3	10	32	36	5.5	28	M6	2.96×10 ⁻⁴	0.18	0.91

Note) Models MDK0401, 0601 and 0801 are not provided with a seal.

For model number coding, see **A15-230**.

WHF (Precision Ball Screw) No Preload

DN value	120000
----------	--------

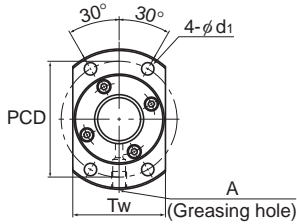

WHF1530/1540/2020/2025/
2030/2040/2550

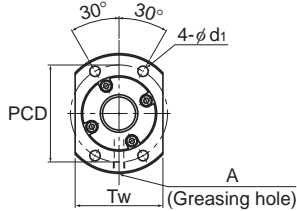

WHF2525

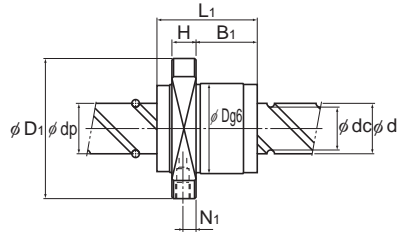

Unit: mm

Model No.	Screw shaft outer diameter	Lead	Ball center-to-center diameter	Thread minor diameter	No. of loaded circuits	Basic load rating		Rigidity	Nut dimensions		
						Ca	C _{0a}		Outer diameter	Flange diameter	Overall length
						kN	kN	K			
WHF 1530-3.4	15	30	15.75	12.5	2 × 1.7	8	14.4	195	32	53	64.5
WHF 1540-3.4	15	40	15.75	12.5	2 × 1.7	7.7	16.3	209	34	57	81.6
WHF 2020-3.4	20	20	20.75	17.5	2 × 1.7	9.6	21	225	42	64	47.1
WHF 2025-3.4	20	25	20.75	17.6	2 × 1.7	9.8	22.3	236	39	62	56.2
WHF 2030-3.4	20	30	20.75	17.6	2 × 1.7	9.9	23.5	243	39	62	65.3
WHF 2040-3.4	20	40	20.75	17.5	2 × 1.7	9.6	20.3	256	37	57	82.7
WHF 2525-3.4	25	25	26	21.9	2 × 1.7	14.5	33.1	285	50	77	58.8
WHF 2550-3.4	25	50	26	21.9	2 × 1.7	14.4	31.9	323	45	69	103.3

Model No.	Nut dimensions							Screw shaft inertial moment/mm	Nut mass	Shaft mass
	H	B ₁	PCD	d ₁	Tw	N ₁	Greasing hole			
WHF 1530-3.4	10	47.5	43	5.5	33	5	M6	3.9 × 10 ⁻⁴	0.38	1.26
WHF 1540-3.4	10	64.6	45	5.5	40	5	M6	3.9 × 10 ⁻⁴	0.48	1.28
WHF 2020-3.4	10	24.1	53	5.5	46	5	M6	1.23 × 10 ⁻³	0.49	2.25
WHF 2025-3.4	10	33.2	50	5.5	46	5	M6	1.23 × 10 ⁻³	0.51	2.26
WHF 2030-3.4	10	43.3	50	5.5	46	5	M6	1.23 × 10 ⁻³	0.55	2.28
WHF 2040-3.4	10	65.7	47	5.5	38	5	M6	1.23 × 10 ⁻³	0.58	2.34
WHF 2525-3.4	12	31.3	63	6.6	56	6	M6	3.01 × 10 ⁻³	0.65	3.52
WHF 2550-3.4	12	79.3	57	6.6	46	6	M6	3.01 × 10 ⁻³	0.72	3.66

Note) Model WHF cannot be attached with seal.

The overall length of the nut will increase when equipping the QZ lubricating device. See **A15-344** for further details.

For model number coding, see **A15-230**.

BLK (Precision Ball Screw) No Preload

DN value	7000
----------	------

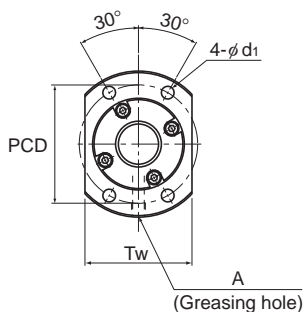

Model No.	Screw shaft outer diameter d	Lead Ph	Ball center-to-center diameter dp	Thread minor diameter dc	No. of loaded circuits Rows X turns	Basic load rating		Rigidity K N/μm
						Ca kN	C _{0a} kN	
BLK 1510-5.6	15	10	15.75	12.5	2×2.8	14.3	27.8	340
BLK 1616-2.8	16	16	16.65	13.7	1×2.8	5.2	9.9	180
BLK 1616-3.6	16	16	16.65	13.7	2×1.8	7.1	14.3	220
BLK 2020-2.8	20	20	20.75	17.5	1×2.8	8.1	17.2	230
BLK 2020-3.6	20	20	20.75	17.5	2×1.8	11.1	24.7	290
BLK 2525-2.8	25	25	26	21.9	1×2.8	12.2	26.9	270
BLK 2525-3.6	25	25	26	21.9	2×1.8	16.6	38.7	350
BLK 3232-2.8	32	32	33.25	28.3	1×2.8	17.3	41.4	340
BLK 3232-3.6	32	32	33.25	28.3	2×1.8	23.7	59.5	440
BLK 3620-5.6	36	20	37.75	31.2	2×2.8	54.9	134.3	760
BLK 3624-5.6	36	24	38	30.7	2×2.8	63.8	151.9	770
BLK 3636-2.8	36	36	37.4	31.7	1×2.8	22.4	54.1	390
BLK 3636-3.6	36	36	37.4	31.7	2×1.8	30.8	78	490
BLK 4040-2.8	40	40	41.75	35.2	1×2.8	28.2	68.9	430
BLK 4040-3.6	40	40	41.75	35.2	2×1.8	38.7	99.2	550
BLK 5050-2.8	50	50	52.2	44.1	1×2.8	42.2	107.8	530
BLK 5050-3.6	50	50	52.2	44.1	2×1.8	57.8	155	670

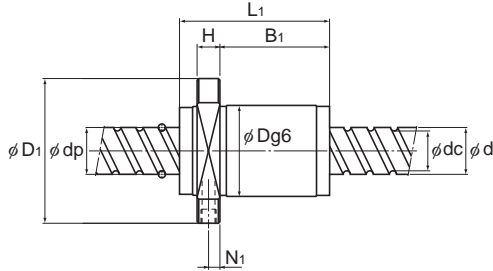

Unit: mm

	Nut dimensions										Screw shaft inertial moment/mm kg-cm ² /mm	Nut mass kg	Shaft mass kg/m
	Outer diameter D	Flange diameter D ₁	Overall length L ₁	H	B ₁	PCD	d _i	Tw	N ₁	Greasing hole A			
	34	57	44	10	24	45	5.5	40	5	M6	3.9×10^{-4}	0.34	0.31
	32	53	54	10	37.5	42	4.5	38	5	M6	5.05×10^{-4}	0.32	1.41
	32	53	38	10	21.5	42	4.5	38	5	M6	5.05×10^{-4}	0.21	1.41
	39	62	65	10	47.5	50	5.5	46	5	M6	1.23×10^{-3}	0.49	2.25
	39	62	45	10	27.5	50	5.5	46	5	M6	1.23×10^{-3}	0.35	2.25
	47	74	80	12	60	60	6.6	56	6	M6	3.01×10^{-3}	0.89	3.52
	47	74	55	12	35	60	6.6	56	6	M6	3.01×10^{-3}	0.64	3.52
	58	92	102	15	77	74	9	68	7.5	M6	8.08×10^{-3}	1.78	5.83
	58	92	70	15	45	74	9	68	7.5	M6	8.08×10^{-3}	1.32	5.83
	70	110	78	17	45	90	11	80	8.5	M6	1.29×10^{-2}	2.23	6.49
	75	115	94	18	59	94	11	86	9	M6	1.29×10^{-2}	3.05	6.39
	66	106	113	17	86	85	11	76	8.5	M6	1.29×10^{-2}	2.61	7.34
	66	106	77	17	50	85	11	76	8.5	M6	1.29×10^{-2}	1.93	7.34
	73	114	125	17	96.5	93	11	84	8.5	M6	1.97×10^{-2}	3.4	9.01
	73	114	85	17	56.5	93	11	84	8.5	M6	1.97×10^{-2}	2.48	9.01
	90	135	156	20	122	112	14	104	10	M6	4.82×10^{-2}	6.18	14.08
	90	135	106	20	72	112	14	104	10	M6	4.82×10^{-2}	4.45	14.08

Note) Model BLK cannot be attached with seal.

The overall length of the nut will increase when equipping the QZ lubricating device. See **A15-344** for further details.For model number coding, see **A15-230**.

WGF No Preload

DN value	70000
----------	-------

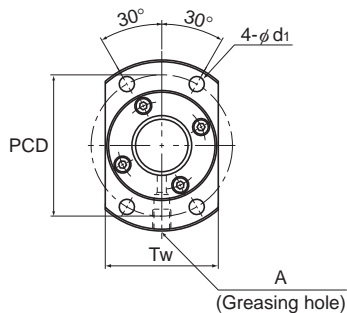

Model No.	Screw shaft outer diameter d	Lead Ph	Ball center-to-center diameter dp	Thread minor diameter dc	No. of loaded circuits Rows × turns	Basic load rating		Rigidity K N/μm
						Ca kN	Ca'a kN	
WGF 0812-3	8	12	8.4	6.6	2×1.65	2.2	3.9	110
WGF 1015-3	10	15	10.5	8.3	2×1.65	3.3	6.2	140
WGF 1320-3	13	20	13.5	10.8	2×1.65	4.7	9.6	180
WGF 1520-1.5	15	20	15.75	12.5	1×1.5	4.4	7.9	100
WGF 1520-3	15	20	15.75	12.5	2×1.5	8.1	15.8	190
WGF 1530-1	15	30	15.75	12.5	2×0.6	3.5	5.4	90
WGF 1530-3	15	30	15.75	12.5	2×1.6	8.1	14.6	220
WGF 1540-1.5	15	40	15.75	12.5	2×0.75	3.9	7.4	110
WGF 2040-1	20	40	20.75	17.5	2×0.65	4.3	8	110
WGF 2040-3	20	40	20.75	17.5	2×1.65	9.5	20.2	280
WGF 2060-1.5	20	60	20.75	17.5	2×0.75	4.5	11	140
WGF 2550-1	25	50	26	21.9	2×0.65	6.4	12.5	140
WGF 2550-3	25	50	26	21.9	2×1.65	14.3	31.7	340
WGF 3060-1	30	60	31.25	26.4	2×0.65	8.9	18	170
WGF 3060-3	30	60	31.25	26.4	2×1.65	19.9	45.7	410
WGF 3090-1.5	30	90	31.25	26.4	2×0.75	9.7	25.8	200
WGF 4080-1	40	80	41.75	35.2	2×0.65	15	32.1	220
WGF 4080-3	40	80	41.75	35.2	2×1.65	33.4	81.4	530
WGF 50100-1	50	100	52.2	44.1	2×0.65	22.4	50.1	270
WGF 50100-3	50	100	52.2	44.1	2×1.65	49.9	127.2	650

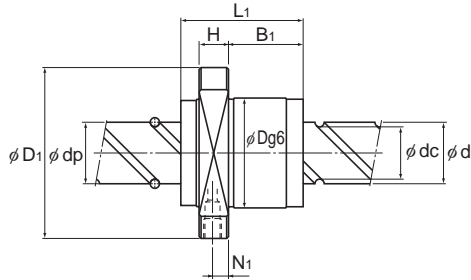

Unit: mm

	Nut dimensions										Screw shaft inertial moment/mm kg-cm ² /mm	Nut mass kg	Shaft mass kg/m	
	Outer diameter	Flange diameter	Overall length											Greasing hole
	D	D ₁	L ₁	H	B ₁	PCD	d ₁	Tw	N ₁	A				
	18	31	27	4	17	25	3.4	20	—	—	3.16 × 10 ⁻⁵	0.054	0.35	
	23	40	33	5	22	32	4.5	25	—	—	7.71 × 10 ⁻⁵	0.11	0.55	
	28	45	43	5	29	37	4.5	30	—	—	2.2 × 10 ⁻⁴	0.18	0.96	
	32	53	45	10	28	43	5.5	33	5	M6	3.9 × 10 ⁻⁴	0.29	1.22	
	32	53	45	10	28	43	5.5	33	5	M6	3.9 × 10 ⁻⁴	0.29	1.22	
	32	53	33	10	17	43	5.5	33	5	M6	3.9 × 10 ⁻⁴	0.23	1.26	
	32	53	63	10	47	43	5.5	33	5	M6	3.9 × 10 ⁻⁴	0.38	1.26	
	32	53	42	10	26.3	43	5.5	33	5	M6	3.9 × 10 ⁻⁴	0.28	1.28	
	37	57	41	10	25	47	5.5	38	5.5	M6	1.23 × 10 ⁻³	0.24	2.34	
	37	57	81	10	65	47	5.5	38	5.5	M6	1.23 × 10 ⁻³	0.48	2.34	
	37	57	60	10	40.1	47	5.5	38	5	M6	1.23 × 10 ⁻³	0.4	2.37	
	45	69	52	12	31.5	57	6.6	46	7	M6	3.01 × 10 ⁻³	0.43	3.66	
	45	69	102	12	81.5	57	6.6	46	7	M6	3.01 × 10 ⁻³	0.85	3.66	
	55	89	62	15	37	71	9	56	9	M6	6.24 × 10 ⁻³	1.11	5.28	
	55	89	122	15	97	71	9	56	9	M6	6.24 × 10 ⁻³	1.9	5.28	
	55	89	92	15	61.3	71	9	56	9	M6	6.24 × 10 ⁻³	1.51	5.34	
	73	114	79	17	50.5	93	11	74	8.5	M6	1.97 × 10 ⁻²	2.34	9.38	
	73	114	159	17	130.5	93	11	74	8.5	M6	1.97 × 10 ⁻²	4.18	9.38	
	90	135	98	20	64	112	14	92	10	M6	4.82 × 10 ⁻²	4.18	14.66	
	90	135	198	20	164	112	14	92	10	M6	4.82 × 10 ⁻²	7.63	14.66	

Note) Model WGF cannot be attached with seal.

The overall length of the nut will increase when equipping the QZ lubricating device. See **A15-344** for further details.

For model number coding, see **A15-230**.

BNT (Precision Ball Screw) No Preload

DN value	70000
----------	-------

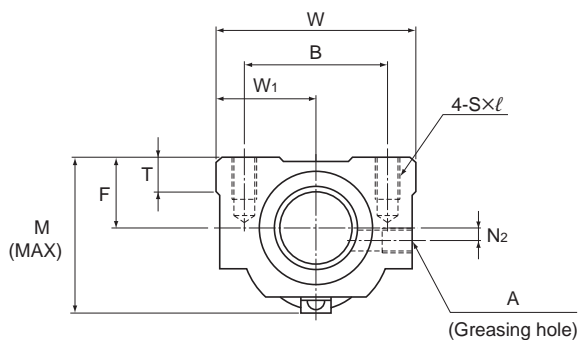

Model No.	Screw shaft outer diameter d	Lead Ph	Ball center-to-center diameter dp	Thread minor diameter dc	No. of loaded circuits Rows × turns	Basic load rating		Rigidity K N/μm
						Ca kN	C _{0a} kN	
BNT 1404-3.6	14	4	14.4	11.5	1×3.65	6.8	12.6	190
BNT 1405-2.6	14	5	14.5	11.2	1×2.65	7.2	12.6	150
BNT 1605-2.6	16	5	16.75	13.5	1×2.65	7.8	14.7	170
BNT 1808-3.6	18	8	19.3	14.4	1×3.65	18.2	34.4	270
BNT 2005-2.6	20	5	20.5	17.2	1×2.65	8.7	18.3	200
BNT 2010-2.6	20	10	21.25	16.4	1×2.65	14.7	27.8	220
BNT 2505-2.6	25	5	25.5	22.2	1×2.65	9.6	23	240
BNT 2510-5.3	25	10	26.8	20.2	2×2.65	43.4	92.8	520
BNT 2806-2.6	28	6	28.5	25.2	1×2.65	10.1	25.8	270
BNT 2806-5.3	28	6	28.5	25.2	2×2.65	18.3	51.6	510
BNT 3210-2.6	32	10	33.75	27.2	1×2.65	27.3	59.5	330
BNT 3210-5.3	32	10	33.75	27.2	2×2.65	49.6	118.9	640
BNT 3610-2.6	36	10	37	30.5	1×2.65	28.7	65.6	360
BNT 3610-5.3	36	10	37	30.5	2×2.65	52.1	131.2	700
BNT 4512-5.3	45	12	46.5	39.2	2×2.65	68.1	186.7	860

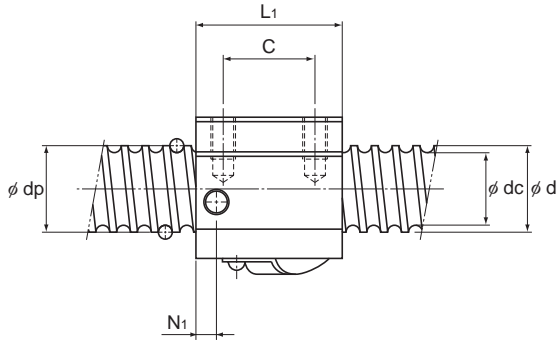

Unit: mm

	Nut dimensions											Screw shaft inertial moment/mm kg-cm ² /mm	Nut mass kg	Shaft mass kg/m	
	Outer diameter D	Center height F	Overall length L ₁	Mounting hole			W ₁	T	M	N ₁	N ₂				Greasing hole A
				B	C	S × ℓ									
34	13	35	26	22	M4×7	17	6	30	6	2	M6	2.96 × 10 ⁻⁴	0.15	0.93	
34	13	35	26	22	M4×7	17	6	31	6	2	M6	2.96 × 10 ⁻⁴	0.15	0.92	
42	16	36	32	22	M5×8	21	21.5	32.5	6	2	M6	5.05 × 10 ⁻⁴	0.3	1.24	
48	17	56	35	35	M6×10	24	10	44	8	3	M6	8.09 × 10 ⁻⁴	0.47	1.46	
48	17	35	35	22	M6×10	24	9	39	5	3	M6	1.23 × 10 ⁻³	0.28	2.06	
48	18	58	35	35	M6×10	24	9	46	10	2	M6	1.23 × 10 ⁻³	0.5	1.99	
60	20	35	40	22	M8×12	30	9.5	45	7	5	M6	3.01 × 10 ⁻³	0.41	3.35	
60	23	94	40	60	M8×12	30	10	55	10	—	M6	3.01 × 10 ⁻³	1.18	2.79	
60	22	42	40	18	M8×12	30	10	50	8	—	M6	4.74 × 10 ⁻³	0.81	4.42	
60	22	67	40	40	M8×12	30	10	50	8	—	M6	4.74 × 10 ⁻³	0.78	4.42	
70	26	64	50	45	M8×12	35	12	62	10	—	M6	8.08 × 10 ⁻³	1.3	4.98	
70	26	94	50	60	M8×12	35	12	62	10	—	M6	8.08 × 10 ⁻³	2	4.98	
86	29	64	60	45	M10×16	43	17	67	11	—	M6	1.29 × 10 ⁻²	1.8	6.54	
86	29	96	60	60	M10×16	43	17	67	11	—	M6	1.29 × 10 ⁻²	2.4	6.54	
100	36	115	75	75	M12×20	50	20.5	80	13	—	M6	3.16 × 10 ⁻²	4.1	10.56	

Note) The overall length of the nut will increase when equipping the QZ lubricating device. See [A15-344](#) for further details.
For model number coding, see [A15-230](#).

Model Number Coding

Model number coding

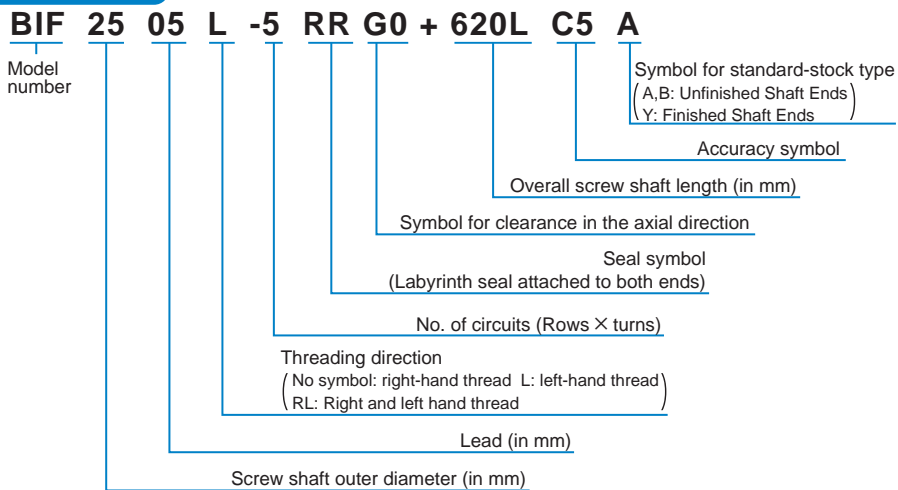

Precision Rotary Ball Screw

Models DIR and BLR

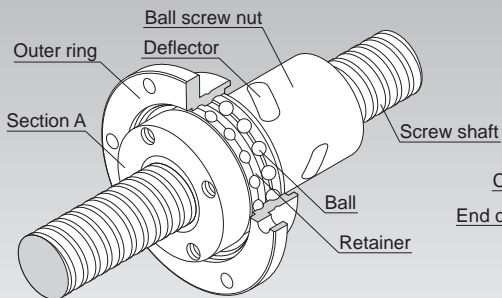

Structure of Standard-Lead Rotary Nut Ball Screw Model DIR

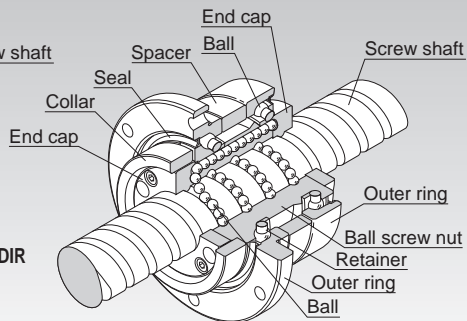

Structure of Large Lead Rotary Nut Ball Screw Model BLR

Point of Selection **A 15-8**

Options **A 15-336**

Model No. **A 15-353**

Precautions on Use **A 15-358**

Accessories for Lubrication **A 24-1**

Mounting Procedure and Maintenance **B 15-104**

Accuracy Standards **A 15-236**

Example of Assembly **A 15-238**

Axial Clearance **A 15-19**

Maximum Length of the Screw Shaft **A 15-24**

DN Value **A 15-33**

Structure and Features

[Model DIR]

Standard-Lead Rotary-Nut Ball Screw model DIR is a rotary-nut Ball Screw that has a structure where a simple-nut Ball Screw is integrated with a support bearing.

Its ball screw nut serves as a ball recirculation structure using deflectors. Balls travel along the groove of the deflector mounted in the ball screw nut to the adjacent raceway, and then circulate back to the loaded area to complete an infinite rolling motion.

Being an offset preload nut, the single ball screw nut provides different phases to the right and left thread in the middle of the nut, thus to set the axial clearance below zero (a preload is provided). This allows more compact, smoother motion to be achieved than the conventional double-nut type (a spacer is inserted between two nuts).

The support bearing comprises of two rows of DB type angular bearings with a contact angle of 45° to provide a preload. The collar, previously used to mount a pulley, is integrated with the ball screw nut. (See the A section.)

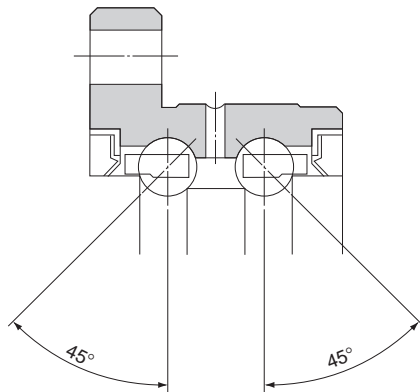

Fig.1 Structure of the Support Bearing

● Compact

Because of the internal circulation mechanism using a deflector, the outer diameter is only 70 to 80%, and the overall length is 60 to 80%, of that of the return-pipe nut, thus to reduce the weight and decrease the inertia during acceleration.

Since the nut and the support bearing are integrated, a highly accurate, and a compact design is achieved. In addition, small inertia due to the lightweight ball screw nut ensures high responsiveness.

● Capable of Fine Positioning

Being a Standard-Lead Ball Screw, it is capable of fine positioning despite that the ball screw nut rotates.

● Accuracy can Easily be Established

As the support bearing is integrated with the outer ring, the bearing can be assembled with the nut housing on the end face of the outer ring flange. This makes it easy to center the ball screw nut and establish accuracy.

● Well Balanced

Since the deflector is evenly placed along the circumference, a superb balance is ensured while the ball screw nut is rotating.

- **Stability in the Low-speed Range**

Traditionally, motors tend to have an uneven torque and a speed in the low-speed range due to the external causes. With model DIR, the motor can be connected independently with the screw shaft and the ball screw nut, thus to allow micro feeding within the motor's stable rotation range.

[Model BLR]

The Rotary Ball Screw is a rotary-nut ball screw unit that has an integrated structure consisting of a ball screw nut and a support bearing. The support bearing is an angular bearing that has a contact angle of 60°, contains an increased number of balls and achieves large axial rigidity.

Model BLR is divided into two types: Precision Ball Screw and Rolled Screw Ball.

- **Smooth Motion**

It achieves smoother motion than rack-and-pinion based straight motion.

- **Low Noise even in High-speed Rotation**

Model BLR produces very low noise when the balls are picked up along the end cap. In addition, the balls circulate by passing through the ball screw nut, allowing this model to be used at high speed.

- **High Rigidity**

The support bearing of this model is larger than that of the screw shaft rotational type. Thus, its axial rigidity is significantly increased.

- **Compact**

Since the nut and the support bearing are integrated, a highly accurate, and a compact design is achieved.

- **Easy Installation**

By simply mounting this model to the housing with bolts, a ball screw nut rotating mechanism can be obtained. (For the housing's inner-diameter tolerance, H7 is recommended.)

Type

[Preload Type]

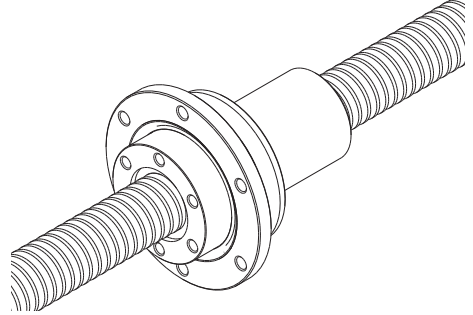
Model DIRSpecification Table⇒ **A15-240**

[No Preload Type]

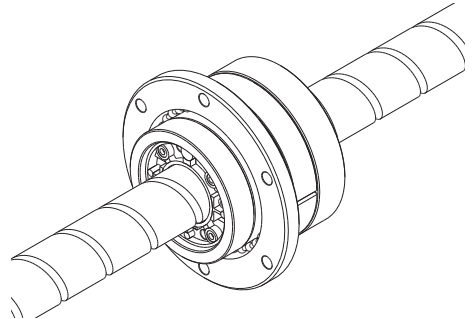
Model BLRSpecification Table⇒ **A15-242**

Accuracy Standards

[Model DIR]

The accuracy of model DIR is compliant with a the JIS standard (JIS B 1192-1997) except for the radial runout of the circumference of the ball screw nut from the screw axis (D) and the perpendicularity of the flange-mounting surface against the screw axis (C).

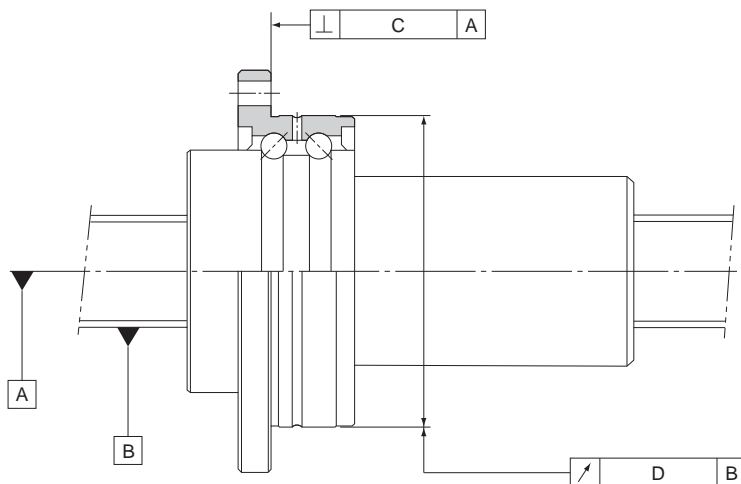

Unit: mm

Accuracy grades	C3		C5		C7	
Model No.	C	D	C	D	C	D
DIR 16□□	0.013	0.017	0.016	0.020	0.023	0.035
DIR 20□□	0.013	0.017	0.016	0.020	0.023	0.035
DIR 25□□	0.015	0.020	0.018	0.024	0.023	0.035
DIR 32□□	0.015	0.020	0.018	0.024	0.023	0.035
DIR 36□□	0.016	0.021	0.019	0.025	0.024	0.036
DIR 40□□	0.018	0.026	0.021	0.033	0.026	0.036

[Model BLR]

The accuracy of model BLR is compliant with a the JIS standard (JIS B 1192-1997) except for the radial runout of the circumference of the ball screw nut from the screw axis (D) and the perpendicularity of the flange-mounting surface against the screw axis (C).

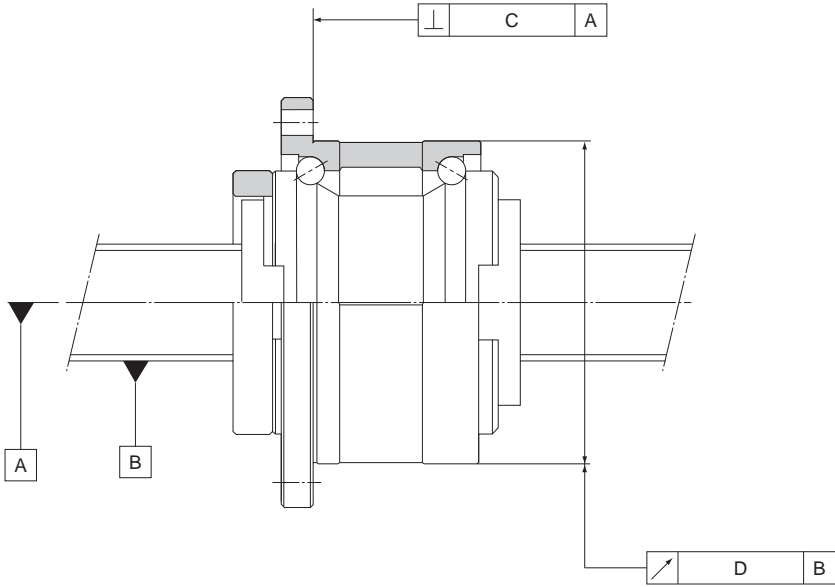

Unit: mm

Lead angle accuracy	C3		C5		C7	
Accuracy grades	C3		C5		C7	
Model No.	C	D	C	D	C	D
BLR 1616	0.013	0.017	0.016	0.020	0.023	0.035
BLR 2020	0.013	0.017	0.016	0.020	0.023	0.035
BLR 2525	0.015	0.020	0.018	0.024	0.023	0.035
BLR 3232	0.015	0.020	0.018	0.024	0.023	0.035
BLR 3636	0.016	0.021	0.019	0.025	0.024	0.036
BLR 4040	0.018	0.026	0.021	0.033	0.026	0.046
BLR 5050	0.018	0.026	0.021	0.033	0.026	0.046

Example of Assembly

[Example of Mounting Ball Screw Nut Model DIR]

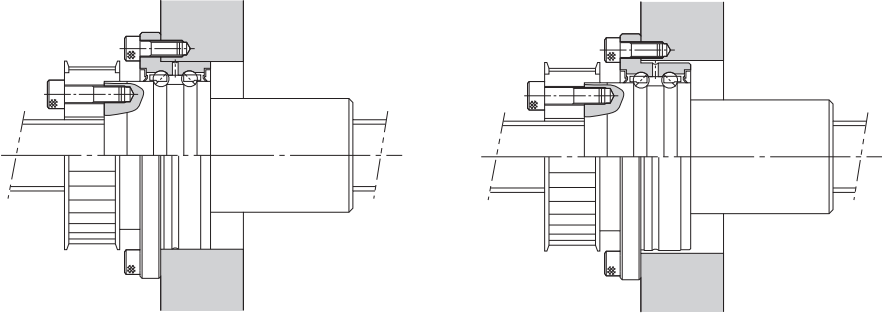

Installation to the housing can be performed on the end face of the outer ring flange.

[Example of Mounting Ball Screw Nut Model BLR]

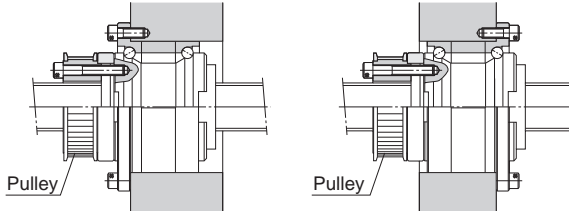

Standard installation method

Inverted flange

Note) If the flange is to be inverted, indicate "K" in the model number. (applicable only to model BLR)

Example: BLR 2020-3.6 K UU

Symbol for inverted flange (No symbol for standard flange orientation)

[Important note concerning model BLR]

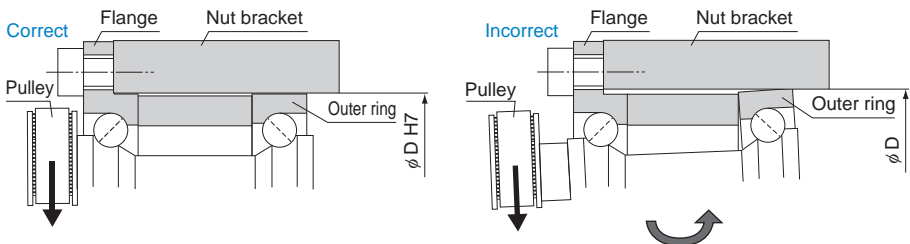

Note) Since the outer rings are separable, it is necessary to include an internal diameter tolerance in the nut bracket so that the outer ring on the side opposite from the flange does not shift. (H7 is recommended.)

[Example of Mounting Model BLR on the Table]

- (1) Screw shaft free, ball screw nut fixed
(Suitable for a long table)

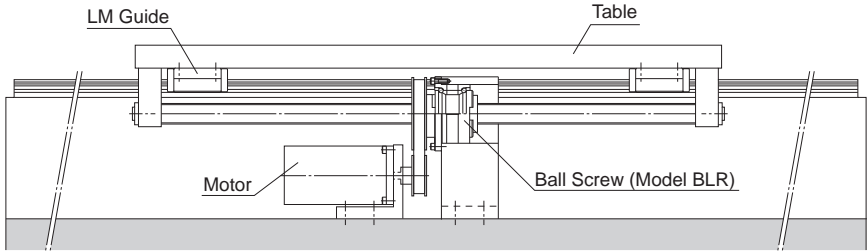

Fig.2 Example of Installation on the Table (Ball Screw Nut Fixed)

- (2) Ball screw nut free, screw shaft fixed
(Suitable for a short table and a long stroke)

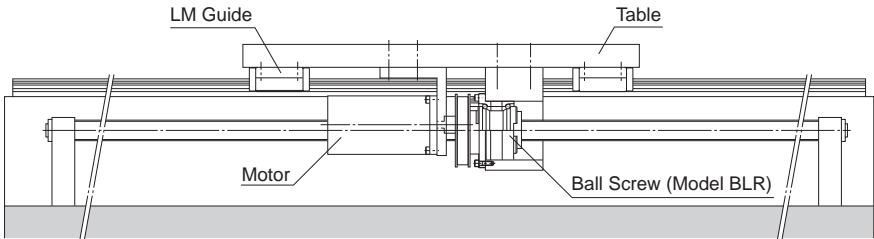
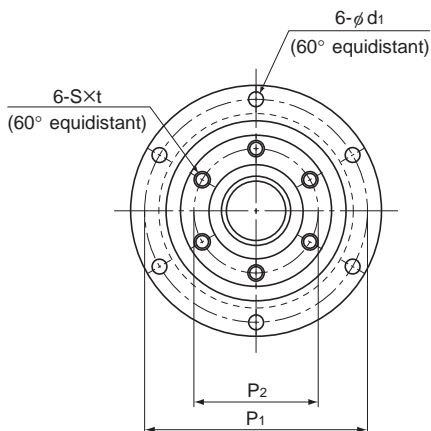

Fig.3 Example of Installation on the Table (Screw Shaft Fixed)

DIR With Preload

DN value	70000
----------	-------



Model No.	Screw shaft outer diameter	Thread minor diameter	Lead	Ball center-to-center diameter	Basic load rating		Rigidity					
					Ca	C _{0a}		K	Outer diameter	Flange diameter	Overall length	D _s
d	dc	Ph	dp	kN	kN	N/μm	D	D ₁	L ₁	h7		
DIR 1605-6	16	13.2	5	16.75	7.4	13	310	48	64	79	36	
DIR 2005-6	20	17.2	5	20.75	8.5	17.3	310	56	72	80	43.5	
DIR 2505-6	25	22.2	5	25.75	9.7	22.6	490	66	86	88	52	
DIR 2510-4		21.6	10	26	9	18	330	66	86	106	52	
DIR 3205-6	32	29.2	5	32.75	11.1	30.2	620	78	103	86	63	
DIR 3206-6		28.4	6	33	14.9	37.1	630	78	103	97	63	
DIR 3210-6		26.4	10	33.75	25.7	52.2	600	78	103	131	63	
DIR 3610-6	36	30.5	10	37.75	28.8	63.8	710	92	122	151	72	
DIR 4010-6	40	34.7	10	41.75	29.8	69.3	750	100	130	142	79.5	
DIR 4012-6		34.4	12	41.75	30.6	72.3	790	100	130	167	79.5	

Model number coding

DIR2005-6 RR G0 +520L C1

Model number Seal symbol (*1) Overall screw shaft length (in mm)
 Symbol for clearance in the axial direction (*2) Accuracy symbol (*3)

(*1) See [A15-336](#). (*2) See [A15-19](#). (*3) See [A15-12](#).

Precision Rotary Ball Screw

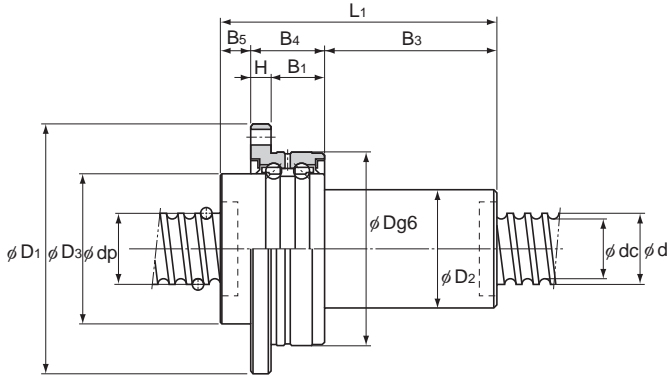

Unit: mm

Ball screw dimensions												Support bearing basic load rating		Nut inertial moment	Nut mass	Shaft mass
D_2	B_5	B_4	B_3	P_1	P_2	H	B_1	S	t	d_1	C_a	C_{0a}	kg-cm ²	kg	kg/m	
												kN	kN			
30	8	21	50	56	30	6	15	M4	6	4.5	8.7	10.5	0.61	0.49	1.24	
34	9	21	50	64	36	6	15	M5	8	4.5	9.7	13.4	1.18	0.68	2.05	
40	13	25	50	75	43	7	18	M6	10	5.5	12.7	18.2	2.65	1.07	3.34	
40	11	25	70	75	43	7	18	M6	10	5.5	12.7	18.2	2.84	1.16	3.52	
46	11	25	50	89	53	8	17	M6	10	6.6	13.6	22.3	5.1	1.39	5.67	
48	11	25	61	89	53	8	17	M6	10	6.6	13.6	22.3	5.68	1.54	5.47	
54	11	25	95	89	53	8	17	M6	10	6.6	13.6	22.3	8.13	2.16	4.98	
58	14	33	104	105	61	10	23	M8	12	9	20.4	32.3	14.7	3.25	6.51	
62	14	33	95	113	67	10	23	M8	12	9	21.5	36.8	20.6	3.55	8.22	
62	14	33	120	113	67	10	23	M8	12	9	21.5	36.8	22.5	3.9	8.5	

Note) The rigidity values in the table represent spring constants, each obtained from the load and the elastic deformation when providing a preload equal to 10% of the basic axial dynamic load rating (C_a) and applying an axial load three times greater than the pre-load.

These values do not include the rigidity of the components related to mounting the ball screw nut. Therefore, it is normally appropriate to regard roughly 80% of the value in the table as the actual value.

If the applied preload (F_{a0}) is not 0.1 C_a , the rigidity value (K_s) is obtained from the following equation.

$$K_s = K \left(\frac{F_{a0}}{0.1 C_a} \right)^3$$

K : Rigidity value in the dimensional table.

BLR (Precision Ball Screw) No Preload

DN value	70000
----------	-------

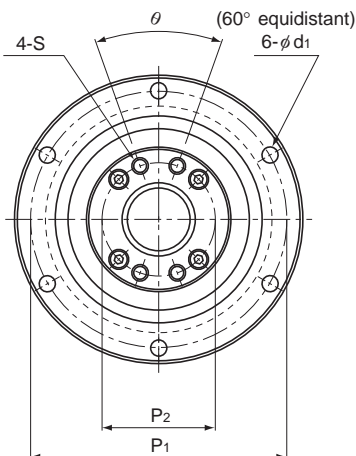

Model No.	Screw shaft outer diameter d	Thread minor diameter dc	Lead Ph	Ball center-to-center diameter dp	Basic load rating		Outer diameter D	Flange diameter D ₁	Overall length L ₁	D ₃
					Ca kN	C _{0a} kN				
BLR 1616-3.6	16	13.7	16	16.65	7.1	14.3	52 ⁰ _{-0.007}	68	43.5	40 ⁰ _{-0.025}
BLR 2020-3.6	20	17.5	20	20.75	11.1	24.7	62 ⁰ _{-0.007}	78	54	50 ⁰ _{-0.025}
BLR 2525-3.6	25	21.9	25	26	16.6	38.7	72 ⁰ _{-0.007}	92	65	58 ⁰ _{-0.03}
BLR 3232-3.6	32	28.3	32	33.25	23.7	59.5	80 ⁰ _{-0.007}	105	80	66 ⁰ _{-0.03}
BLR 3636-3.6	36	31.7	36	37.4	30.8	78	100 ⁰ _{-0.008}	130	93	80 ⁰ _{-0.03}
BLR 4040-3.6	40	35.2	40	41.75	38.7	99.2	110 ⁰ _{-0.008}	140	98	90 ⁰ _{-0.035}
BLR 5050-3.6	50	44.1	50	52.2	57.8	155	120 ⁰ _{-0.008}	156	126	100 ⁰ _{-0.035}

Model number coding

BLR2020-3.6 K UU G1 +1000L C5

Model number | Flange orientation symbol ^{(*)1} | Symbol for clearance in the axial direction ^{(*)3} | Accuracy symbol ^{(*)4}
 Symbol for support bearing seal ^{(*)2} | Overall screw shaft length (in mm)

(*)1 See **A15-238**. (*)2 UU: Seal attached on both ends No symbol: Without seal. (*)3 See **A15-19**. (*)4 See **A15-12**.

Precision Rotary Ball Screw

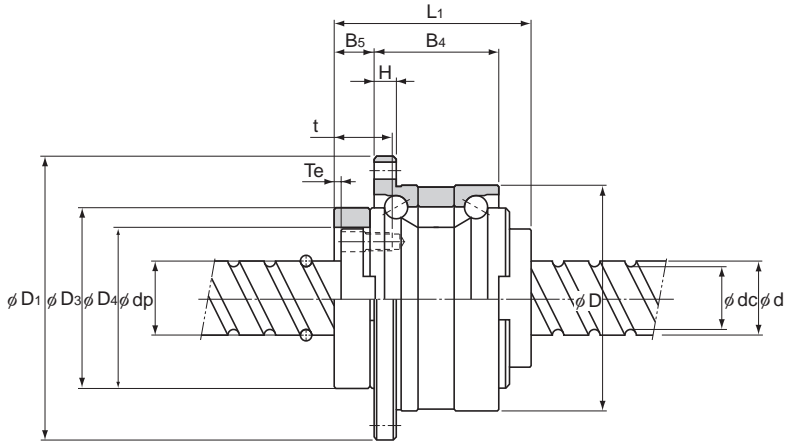

Unit: mm

Ball screw dimensions												Support bearing basic load rating		Nut inertial moment kg-cm ²	Nut mass kg	Shaft mass kg/m
D_4	H	B_4	B_5	T_e	P_1	P_2	S	t	d_1	θ°	Ca kN	C_{0a} kN				
32 ^{+0.025} ₀	5	27.5	9	2	60	25	M4	12	4.5	40	19.4	19.2	0.48	0.38	1.41	
39 ^{+0.025} ₀	6	34	11	2	70	31	M5	16	4.5	40	26.8	29.3	1.44	0.68	2.25	
47 ^{+0.025} ₀	8	43	12.5	3	81	38	M6	19	5.5	40	28.2	33.3	3.23	1.1	3.52	
58 ^{+0.03} ₀	9	55	14	3	91	48	M6	19	6.6	40	30	39	6.74	1.74	5.83	
66 ^{+0.03} ₀	11	62	17	3	113	54	M8	22	9	40	56.4	65.2	16.8	3.2	7.34	
73 ^{+0.03} ₀	11	68	16.5	3	123	61	M8	22	9	50	59.3	74.1	27.9	3.95	9.01	
90 ^{+0.035} ₀	12	80	25	4	136	75	M10	28	11	50	62.2	83	58.2	6.22	14.08	

Ball Screw

Permissible Rotational Speeds for Rotary Ball Screws

The permissible rotational speeds for models DIR and BLR and rotary ball screws is restricted to whichever is lower of the support bearing permissible rotational speed, the DN value (70,000) and the critical speed of the screw. When using the product, do not exceed the permissible rotational speed.

Table1 Model DIR permissible rotational speed

Unit:min⁻¹

Model No.	Permissible Rotational Speed			
	Ball Screw Unit		Support bearing	
	Calculated using shaft length	Calculated using DN value	Grease Lubrication	Oil Lubrication
DIR1605	see A15-32 .	4179	4200	5600
DIR2005		3373	3500	4700
DIR2505		2718	2900	3900
DIR2510		2692	2900	3900
DIR3205		2137	2400	3300
DIR3206		2121	2400	3300
DIR3210		2074	2400	3300
DIR3610		1854	2100	2800
DIR4010		1676	1900	2600
DIR4012		1676	1900	2600

Table2 Model BLR permissible rotational speed

Unit:min⁻¹

Model No.	Permissible Rotational Speed			
	Ball Screw Unit		Support bearing	
	Calculated using shaft length	Calculated using DN value	Grease Lubrication	Oil Lubrication
BLR1616	see A15-32 .	4204	4000	5600
BLR2020		3373	3200	4300
BLR2525		2692	2800	3700
BLR3232		2105	2400	3300
BLR3636		1871	2000	2700
BLR4040		1676	1800	2400
BLR5050		1340	1600	2200

Precision Ball Screw/Spline

Models BNS-A, BNS, NS-A and NS

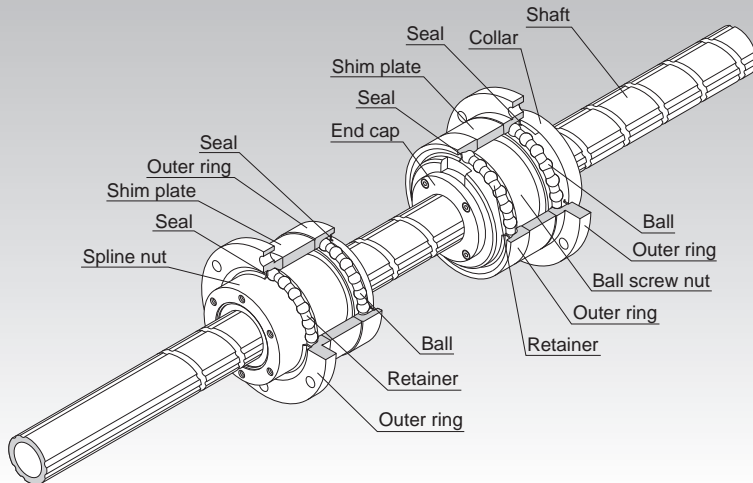

Point of Selection **A15-8**

Options **A15-336**

Model No. **A15-353**

Precautions on Use **A15-358**

Accessories for Lubrication **A24-1**

Mounting Procedure and Maintenance **B15-104**

DN Value **A15-33**

Accuracy Standards **A15-249**

Action Patterns **A15-250**

Example of Assembly **A15-253**

Example of Use **A15-254**

Precautions on Use **A15-255**

Structure and Features

The Ball Screw/Spline contains the Ball Screw grooves and the Ball Spline groove crossing one another. The nuts of the Ball Screw and the Ball Spline have dedicated support bearings directly embedded on the circumference of the nuts.

The Ball Screw/Spline is capable of performing three (rotational, linear and spiral) modes of motion with a single shaft by rotating or stopping the spline nut.

It is optimal for machines using a combination of rotary and straight motions, such as scholar robot's Z-axis, assembly robot, automatic loader, and machining center's ATC equipment.

[Zero Axial Clearance]

The Ball Spline has an angular-contact structure that causes no backlash in the rotational direction, enabling highly accurate positioning.

[Lightweight and Compact]

Since the nut and the support bearing are integrated, highly accurate, compact design is achieved. In addition, small inertia because of the lightweight ball screw nut ensures high responsiveness.

[Easy Installation]

The Ball Spline nut is designed so that balls do not fall off even if the spline nut is removed from the shaft, making installation easy. The Ball Screw/Spline can easily be mounted simply by securing it to the housing with bolts. (For the housing's inner-diameter tolerance, H7 is recommended.)

[Smooth Motion with Low Noise]

As the Ball Screw is based on an end cap mechanism, smooth motion with low noise is achieved.

[Highly Rigid Support Bearing]

The support bearing on the Ball Screw has a contact angle of 60° in the axial direction while that on the Ball Spline has a contact angle of 30° in the moment direction, thus to provide a highly rigid shaft support.

In addition, a dedicated rubber seal is attached as standard to prevent entry of foreign materials.

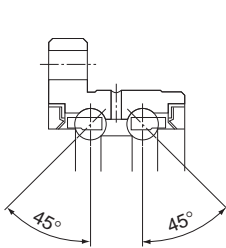

Fig.1 Structure of Support Bearing Model BNS-A

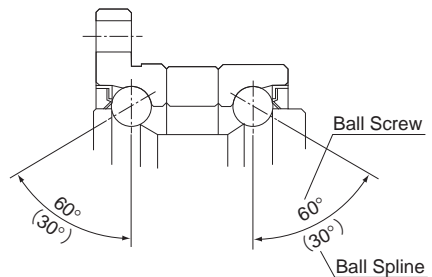

Fig.2 Structure of Support Bearing Model BNS

Type

[No Preload Type]

Model BNS-A

Specification Table⇒ **A 15-256**

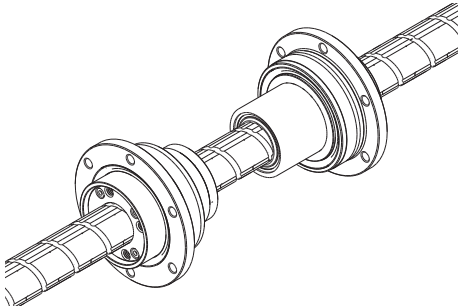

(Compact type: linear-rotary motion)

Model BNS

Specification Table⇒ **A 15-258**

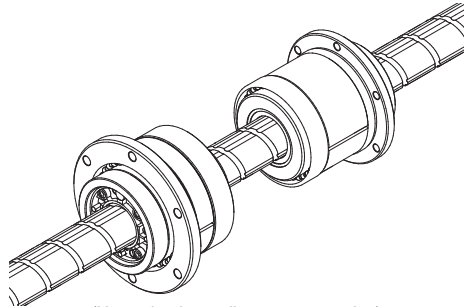

(Heavy-load type: linear-rotary motion)

Model NS-A

Specification Table⇒ **A 15-260**

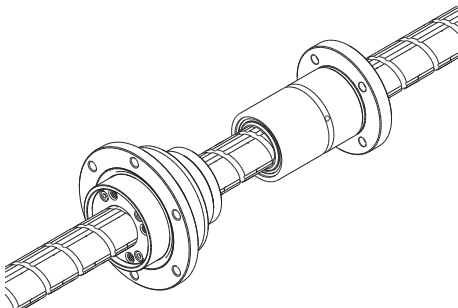

(Compact type: straight motion)

Model NS

Specification Table⇒ **A 15-262**

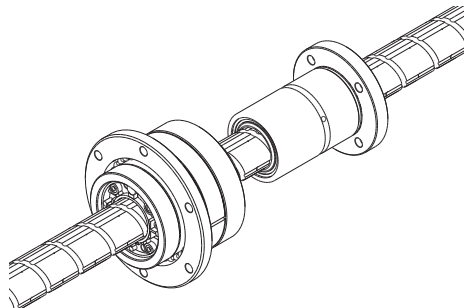

(Heavy-load type: straight motion)

Accuracy Standards

The Ball Screw/Spline is manufactured with the following specifications.

[Ball Screw]

Axial clearance : 0 or less

Lead angle accuracy : C5

(For detailed specifications, see **A15-12**, **A15-19**.)

[Ball Spline]

Clearance in the rotational direction : 0 or less (CL: light preload)

(For detailed specifications, see **A3-30**.)

Accuracy grade : class H

(For detailed specifications, see **A3-34**.)

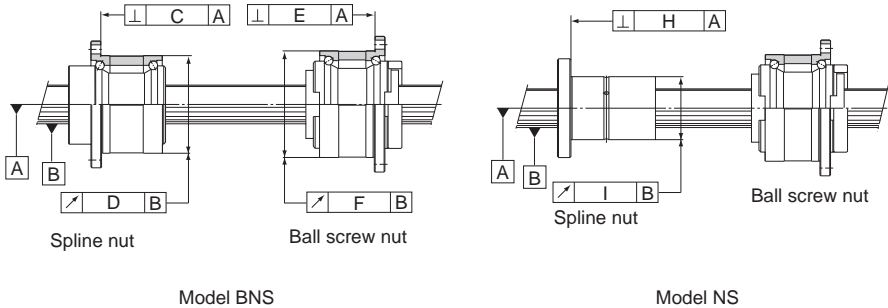

Unit: mm

Model No.	C	D	E	F	H	I
BNS 0812 NS 0812	0.014	0.017	0.014	0.016	0.010	0.013
BNS 1015 NS 1015	0.014	0.017	0.014	0.016	0.010	0.013
BNS 1616 NS 1616	0.018	0.021	0.016	0.020	0.013	0.016
BNS 2020 NS 2020	0.018	0.021	0.016	0.020	0.013	0.016
BNS 2525 NS 2525	0.021	0.021	0.018	0.024	0.016	0.016
BNS 3232 NS 3232	0.021	0.021	0.018	0.024	0.016	0.016
BNS 4040 NS 4040	0.025	0.025	0.021	0.033	0.019	0.019
BNS 5050 NS 5050	0.025	0.025	0.021	0.033	0.019	0.019

Action Patterns

[Model BNS Basic Actions]

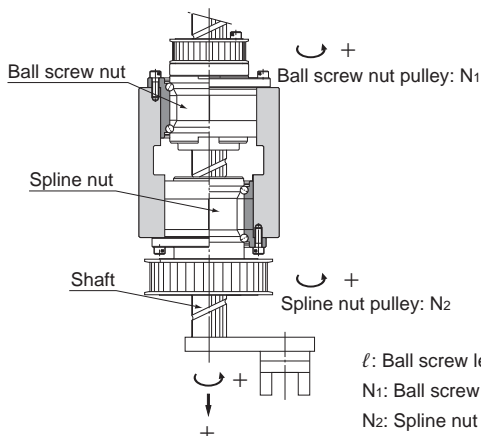

Motion	Action direction	Input		Shaft motion	
		Ball screw pulley	Ball spline pulley	Vertical direction (speed)	Rotational direction (rotation speed)
1. Vertical 	(1) Vertical direction→down Rotational direction→0	N_1 (Forward)	0	$V=N_1 \cdot \ell$ ($N_1 \neq 0$)	0
	(2) Vertical direction→up Rotational direction→0	$-N_1$ (Reverse)	0	$V=-N_1 \cdot \ell$ ($N_1 \neq 0$)	0
2. Rotation 	(1) Vertical direction→0 Rotational direction→forward	N_1	N_2 (Forward)	0	N_2 (Forward) ($N_1=N_2 \neq 0$)
	(2) Vertical direction→0 Rotational direction→reverse	$-N_1$	$-N_2$ (Reverse)	0	$-N_2$ (Reverse) ($-N_1=-N_2 \neq 0$)
3. Spiral 	(1) Vertical direction→up Rotational direction→forward	0	N_2 ($N_2 \neq 0$)	$V=N_2 \cdot \ell$	N_2 (Forward)
	(2) Vertical direction→down Rotational direction→reverse	0	$-N_2$ ($-N_2 \neq 0$)	$V=-N_2 \cdot \ell$	$-N_2$ (Reverse)

[Model NS Basic Actions]

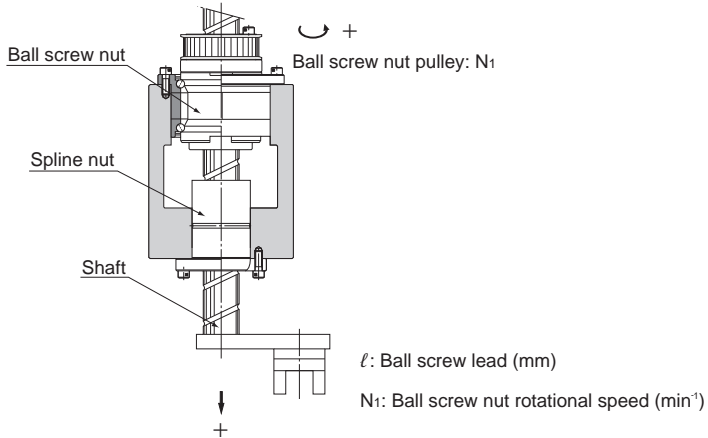

Motion	Action direction	Input	Shaft motion	
		Ball screw pulley	Vertical direction (speed)	
1. Vertical 	(1)	Vertical direction →down	N_1 (Forward)	$V=N_1 \cdot \ell$ ($N_1 \neq 0$)
	(2)	Vertical direction →up	$-N_1$ (Reverse)	$V=-N_1 \cdot \ell$ ($N_1 \neq 0$)

[Model BNS Extended Actions]

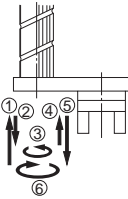
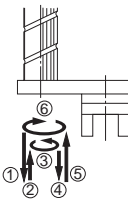
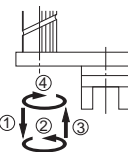
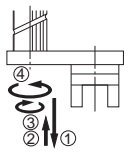
Motion	Action direction	Input		Shaft motion	
		Ball screw pulley	Ball spline pulley	Vertical direction (speed)	Rotational direction (rotational speed)
1. Up→down→forward →up→down→reverse 	(1)	Vertical direction→up $-N_1$ (Reverse)	0	$V=-N_1 \cdot \ell$ ($N_1 \neq 0$)	0
	(2)	Vertical direction→down N_1 (Forward)	0	$V=N_1 \cdot \ell$ ($N_1 \neq 0$)	0
	(3)	Rotational direction→forward N_1	N_2 (Forward)	0	N_2 (Forward) ($N_1=N_2 \neq 0$)
	(4)	Vertical direction→up $-N_1$	0	$V=-N_1 \cdot \ell$ ($N_1 \neq 0$)	0
	(5)	Vertical direction→down N_1	0	$V=N_1 \cdot \ell$ ($N_1 \neq 0$)	0
	(6)	Rotational direction→reverse $-N_1$	$-N_2$ (Reverse)	0	$-N_2$ (Reverse) ($-N_1=N_2 \neq 0$)
2. Down→up→forward →down→up→reverse 	(1)	Vertical direction→down N_1	0	$V=N_1 \cdot \ell$ ($N_1 \neq 0$)	0
	(2)	Vertical direction→up $-N_1$	0	$V=-N_1 \cdot \ell$ ($N_1 \neq 0$)	0
	(3)	Rotational direction→forward N_1	N_2	0	N_2 ($N_1=N_2 \neq 0$)
	(4)	Vertical direction→down N_1	0	$V=N_1 \cdot \ell$ ($N_1 \neq 0$)	0
	(5)	Vertical direction→up $-N_1$	0	$V=-N_1 \cdot \ell$ ($N_1 \neq 0$)	0
	(6)	Rotational direction→reverse $-N_1$	$-N_2$	0	$-N_2$ ($-N_1=N_2 \neq 0$)
3. Down→forward →up→reverse 	(1)	Vertical direction→down N_1	0	$V=N_1 \cdot \ell$ ($N_1 \neq 0$)	0
	(2)	Rotational direction→forward N_1	N_2	0	N_2 ($N_1=N_2 \neq 0$)
	(3)	Vertical direction→up $-N_1$	0	$V=-N_1 \cdot \ell$ ($N_1 \neq 0$)	0
	(4)	Rotational direction→reverse $-N_1$	$-N_2$	0	$-N_2$ ($-N_1=N_2 \neq 0$)
4. Down→up →reverse→forward 	(1)	Vertical direction→down N_1	0	$V=N_1 \cdot \ell$ ($N_1 \neq 0$)	0
	(2)	Vertical direction→up $-N_1$	0	$V=-N_1 \cdot \ell$ ($N_1 \neq 0$)	0
	(3)	Rotational direction→reverse $-N_1$	$-N_2$	0	$-N_2$ ($-N_1=N_2 \neq 0$)
	(4)	Rotational direction→forward N_1	N_2	0	N_2 ($N_1=N_2 \neq 0$)

Example of Assembly

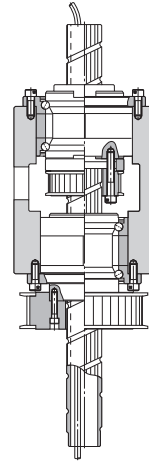
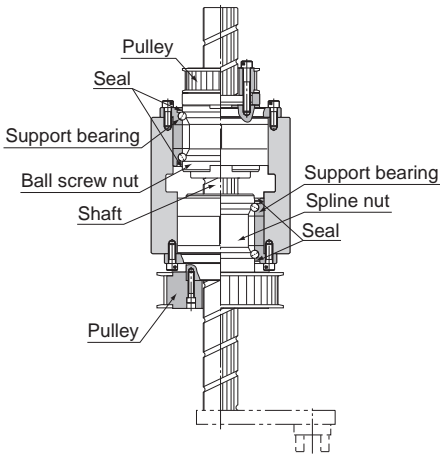

- Example of installing the ball screw nut input pulley

and the spline nut input pulley, both outside the housing.

The housing length is minimized.

- Example of installing the ball screw nut pulley

inside the housing.

Fig.3 Example of Assembling Model BNS

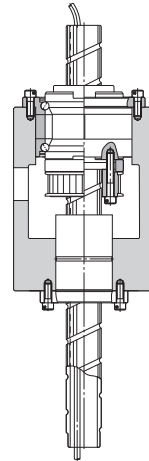
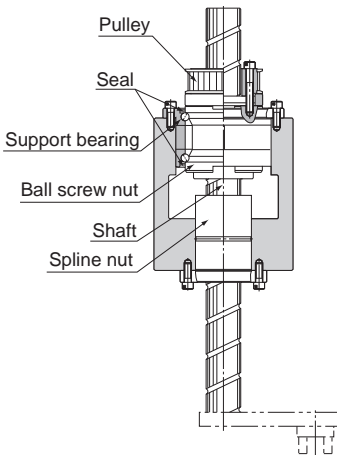

- Example of installing the ball screw nut pulley outside

the housing.

The housing length is minimized.

- Example of installing the ball screw nut pulley

inside the housing.

Fig.4 Example of Assembling Model NS

Example of Use

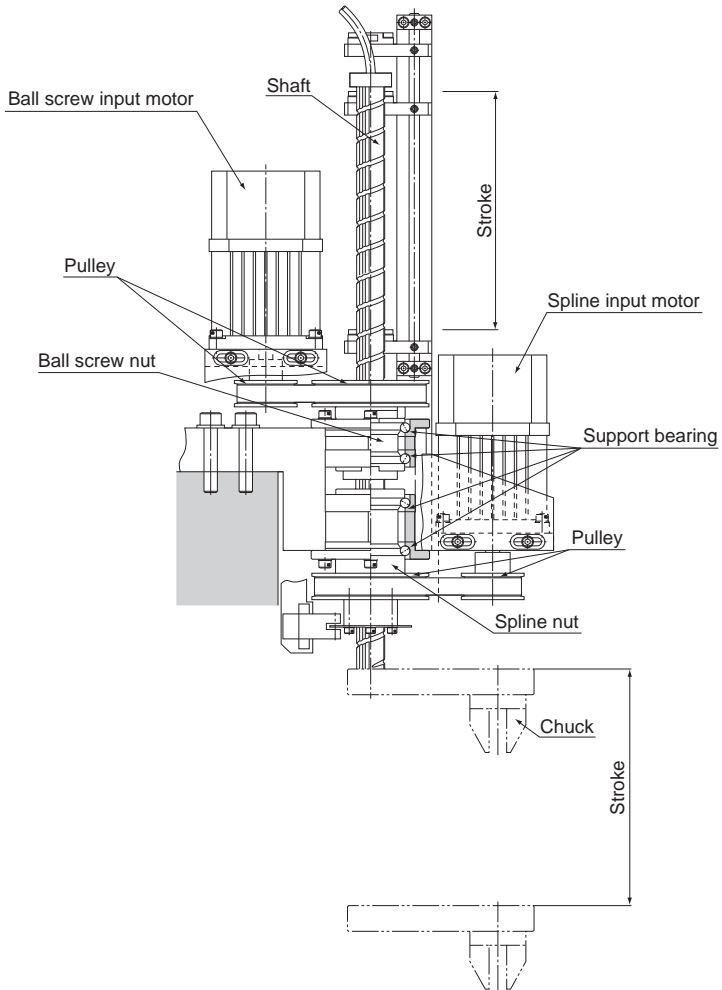

Fig.5 Example of Using Model BNS

Precautions on Use

[Lubrication]

When lubricating the Ball Screw/Spline, attach the greasing plate to the housing in advance.

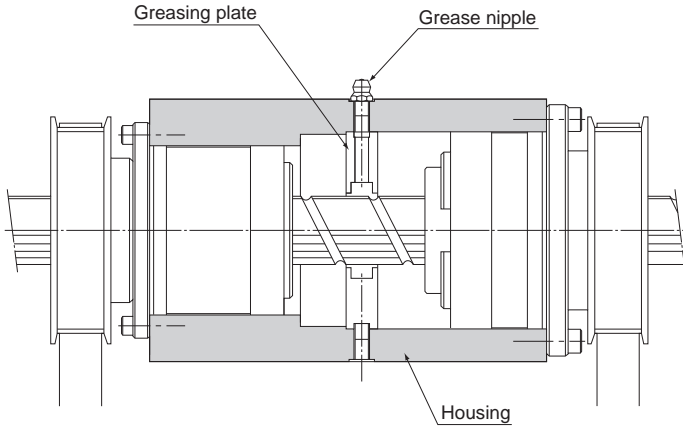
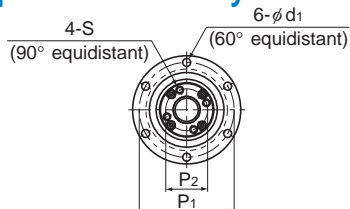

Fig.6 Lubrication Methods

BNS-A Compact Type: Linear-Rotary Motion No Preload

DN value	70000
----------	-------



Ball screw unit
(Models BNS 1616A to 4040A)

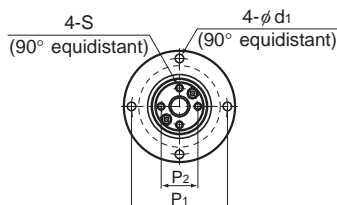

Ball screw unit
(Models BNS 0812A and 1015A)

Ball screw unit

Model No.	Screw shaft outer diameter d	Screw shaft inner diameter db	Lead Ph	Ball screw dimensions								
				Basic load rating		Ball center-to-center diameter dp	Thread minor diameter dc	Outer diameter D	Flange diameter D ₁	Overall length L ₁	D ₃ h7	D ₄ H7
				Ca kN	C _{0a} kN							
BNS 0812A	8	—	12	1.1	1.8	8.4	6.6	32	44	28.5	22	19
BNS 1015A	10	—	15	1.7	2.7	10.5	8.3	36	48	34.5	26	23
BNS 1616A	16	11	16	3.9	7.2	16.65	13.7	48	64	40	36	32
BNS 2020A	20	14	20	6.1	12.3	20.75	17.5	56	72	48	43.5	39
BNS 2525A	25	18	25	9.1	19.3	26	21.9	66	86	58	52	47
BNS 3232A	32	23	32	13	29.8	33.25	28.3	78	103	72	63	58
BNS 4040A	40	29	40	21.4	49.7	41.75	35.2	100	130	88	79.5	73

Ball spline

Model No.	Ball spline dimensions									
	Basic load rating		Static permissible moment M _A N·m	Basic torque rating		Outer diameter D ₇ g6	Flange diameter D ₅	Overall length L ₂	D ₆ h7	BE ₁
	C kN	C ₀ kN		C _T N·m	C _{OT} N·m					
BNS 0812A	1.5	2.6	5.9	2	2.9	32	44	25	24	16
BNS 1015A	2.7	4.9	15.7	3.9	7.8	36	48	33	28	21
BNS 1616A	7.1	12.6	67.6	31.4	34.3	48	64	50	36	31
BNS 2020A	10.2	17.8	118	56.8	55.8	56	72	63	43.5	35
BNS 2525A	15.2	25.8	210	105	103	66	86	71	52	42
BNS 3232A	20.5	34	290	180	157	78	103	80	63	52
BNS 4040A	37.8	60.5	687	418	377	100	130	100	79.5	64

Note) For K hollow shaft, please refer to the db dimension for the inner bore diameter of the shaft. If requested solid shaft is also available. See "Ball Spline" **A3-112** for details.

Model number coding

BNS2020A +500L

Model number Overall shaft length (in mm)

Precision Ball Screw/Spline

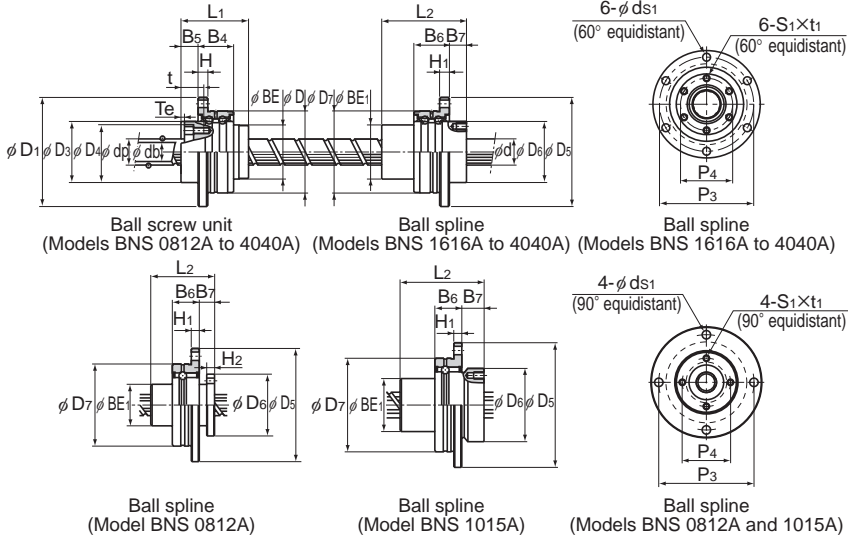

Unit: mm

	BE	H	B ₄	B ₅	T _e	P ₁	P ₂	S	t	d ₁	Support bearing basic load rating		Nut inertial moment kg-cm ²	Screw shaft inertial moment/mm J kg-cm ² /mm	Nut mass kg	Shaft mass kg/m
											Ca	C _{0a}				
	19	3	10.5	7	1.5	38	14.5	M2.6	10	3.4	0.8	0.5	0.03	3.16×10^{-5}	0.08	0.35
	23	3	10.5	8	1.5	42	18	M3	11.5	3.4	0.9	0.7	0.08	7.71×10^{-5}	0.15	0.52
	32	6	21	10	2	56	25	M4	13.5	4.5	8.7	10.5	0.35	3.92×10^{-4}	0.31	0.8
	39	6	21	11	2.5	64	31	M5	16.5	4.5	9.7	13.4	0.85	9.37×10^{-4}	0.54	1.21
	47	7	25	13	3	75	38	M6	20	5.5	12.7	18.2	2.12	2.2×10^{-3}	0.88	1.79
	58	8	25	14	3	89	48	M6	21	6.6	13.6	22.3	5.42	5.92×10^{-3}	1.39	2.96
	73	10	33	16.5	3	113	61	M8	24.5	9	21.5	36.8	17.2	1.43×10^{-2}	3.16	4.51

Unit: mm

	H ₁	B ₆	B ₇	H ₂	P ₃	P ₄	S ₁ ×t ₁	ds ₁	Support bearing basic load rating		Nut inertial moment kg-cm ²	Nut mass kg
									C	C ₀		
	3	10.5	6	3	38	19	M2.6×3	3.4	0.6	0.2	0.03	0.08
	3	10.5	9	—	42	23	M3×4	3.4	0.8	0.3	0.08	0.13
	6	21	10	—	56	30	M4×6	4.5	6.7	6.4	0.44	0.35
	6	21	12	—	64	36	M5×8	4.5	7.4	7.8	0.99	0.51
	7	25	13	—	75	44	M5×8	5.5	9.7	10.6	2.2	0.79
	8	25	17	—	89	54	M6×10	6.6	10.5	12.5	5.17	1.25
	10	33	20	—	113	68	M6×10	9	16.5	20.7	16.1	2.51

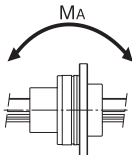

BNS Heavy Load Type: Linear-Rotary Motion No Preload

DN value	70000
----------	-------

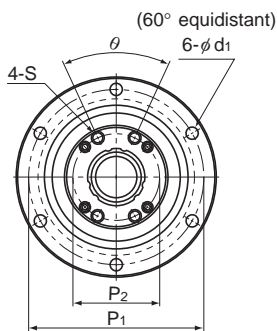

Ball screw unit

Ball screw unit

Model No.	Screw shaft outer diameter d	Screw shaft inner diameter db	Lead Ph	Ball screw dimensions							
				Basic load rating		Ball center-to-center diameter dp	Thread minor diameter dc	Outer diameter D	Flange diameter D ₁	Overall length L ₁	D ₃ h7
				Ca kN	C _{0a} kN						
BNS 1616	16	11	16	3.9	7.2	16.65	13.7	52 ⁰ _{-0.007}	68	43.5	40
BNS 2020	20	14	20	6.1	12.3	20.75	17.5	62 ⁰ _{-0.007}	78	54	50
BNS 2525	25	18	25	9.1	19.3	26	21.9	72 ⁰ _{-0.007}	92	65	58
BNS 3232	32	23	32	13	29.8	33.25	28.3	80 ⁰ _{-0.007}	105	80	66
BNS 4040	40	29	40	21.4	49.7	41.75	35.2	110 ⁰ _{-0.008}	140	98	90
BNS 5050	50	36	50	31.8	77.6	52.2	44.1	120 ⁰ _{-0.008}	156	126	100

Ball spline

Model No.	Ball spline dimensions							
	Basic load rating		Static permissible moment M _s N-m	Basic torque rating		Outer diameter D ₇	Flange diameter D ₅	Overall length L ₂
	C kN	C ₀ kN		C _T N-m	C _{OT} N-m			
BNS 1616	7.1	12.6	67.6	31.4	34.3	52 ⁰ _{-0.007}	68	50
BNS 2020	10.2	17.8	118	56.8	55.8	56 ⁰ _{-0.007}	72	63
BNS 2525	15.2	25.8	210	105	103	62 ⁰ _{-0.007}	78	71
BNS 3232	20.5	34	290	180	157	80 ⁰ _{-0.007}	105	80
BNS 4040	37.8	60.5	687	418	377	100 ⁰ _{-0.008}	130	100
BNS 5050	60.9	94.5	1340	842	768	120 ⁰ _{-0.008}	156	125

Note) Dimension U indicates the length from the head of the hexagonal-socket-head type bolt to the ball screw nut end.

For K hollow shaft, please refer to the db dimension for the inner bore diameter of the shaft. If requested solid shaft is also available. See "Ball Spline" **A3-112** for details.

Model number coding

BNS2525 +600L

Model number Overall shaft length (in mm)

Precision Ball Screw/Spline

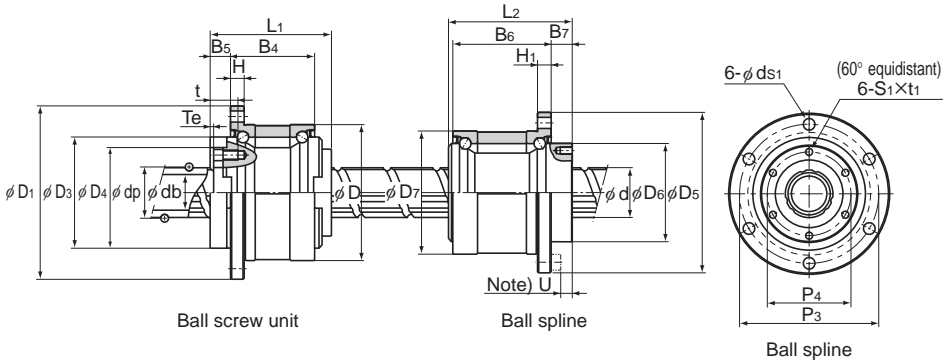

Unit: mm

D ₄	H	B ₄	B ₅	T _e	P ₁	P ₂	S	t	d	θ°	Support bearing basic load rating		Nut inertial moment	Screw shaft inertial moment/mm	Nut mass	Shaft mass
											Ca	C _a				
											kN	kN	kg-cm ²	J kg-cm ² /mm	kg	kg/m
32	5	27.5	9	2	60	25	M4	12	4.5	40	19.4	19.2	0.48	3.92 × 10 ⁻⁴	0.38	0.8
39	6	34	11	2	70	31	M5	16	4.5	40	26.8	29.3	1.44	9.37 × 10 ⁻⁴	0.68	1.21
47	8	43	12.5	3	81	38	M6	19	5.5	40	28.2	33.3	3.23	2.2 × 10 ⁻³	1.1	1.79
58	9	55	14	3	91	48	M6	19	6.6	40	30	39	6.74	5.92 × 10 ⁻³	1.74	2.96
73	11	68	16.5	3	123	61	M8	22	9	50	59.3	74.1	27.9	1.43 × 10 ⁻²	3.95	4.51
90	12	80	25	4	136	75	M10	28	11	50	62.2	83	58.2	3.52 × 10 ⁻²	6.22	7.16

Unit: mm

D ₆	h ₇	H ₁	B ₆	B ₇	P ₃	P ₄	S ₁ × t ₁	d _{s1}	U	Support bearing basic load rating		Nut inertial moment	Nut mass
										C	C _o		
										kN	kN	kg-cm ²	kg
39.5	5	37	10	60	32	32	M5 × 8	4.5	5	12.7	11.8	0.52	0.51
43.5	6	48	12	64	36	36	M5 × 8	4.5	7	16.2	15.5	0.87	0.7
53	6	55	13	70	45	45	M6 × 8	4.5	8	17.6	18	1.72	0.93
65.5	9	60	17	91	55	55	M6 × 10	6.6	10	20.1	24	5.61	1.8
79.5	11	74	23	113	68	68	M6 × 10	9	13	37.2	42.5	14.7	3.9
99.5	12	97	25	136	85	85	M10 × 15	11	13	41.6	54.1	62.5	6.7

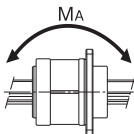

NS-A Compact Type: Linear Motion No Preload

DN value	70000
----------	-------

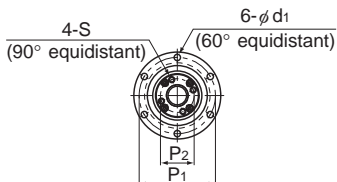

Ball screw unit
(Models NS 1616A to 4040A)

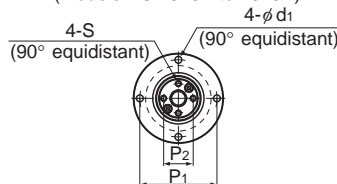

Ball screw unit
(Models NS 0812A and 1015A)

Ball screw unit

Model No.	Screw shaft outer diameter d	Screw shaft inner diameter db	Lead Ph	Ball screw dimensions									
				Basic load rating		Ball center-to-center diameter dp	Thread minor diameter dc	Outer diameter D	Flange diameter D ₁	Overall length L ₁	D ₃ h7	D ₄ H7	
				Ca kN	C _{0a} kN								
NS 0812A	8	—	12	1.1	1.8	8.4	6.6	32	44	28.5	22	19	
NS 1015A	10	—	15	1.7	2.7	10.5	8.3	36	48	34.5	26	23	
NS 1616A	16	11	16	3.9	7.2	16.65	13.7	48	64	40	36	32	
NS 2020A	20	14	20	6.1	12.3	20.75	17.5	56	72	48	43.5	39	
NS 2525A	25	18	25	9.1	19.3	26	21.9	66	86	58	52	47	
NS 3232A	32	23	32	13	29.8	33.25	28.3	78	103	72	63	58	
NS 4040A	40	29	40	21.4	49.7	41.75	35.2	100	130	88	79.5	73	

Ball spline

Model No.	Ball spline dimensions						
	Basic load rating		Static permissible moment M _A N-m	Basic torque rating		Outer diameter D ₇	Flange diameter D ₅ ⁰ _{-0.2}
	C kN	C ₀ kN		C _T N-m	C _{0T} N-m		
NS 0812A	1.5	2.6	5.9	2	2.9	16 ⁰ _{-0.011}	32
NS 1015A	2.8	4.9	15.7	3.9	7.8	21 ⁰ _{-0.013}	42
NS 1616A	7.1	12.6	67.6	31.4	34.3	31 ⁰ _{-0.013}	51
NS 2020A	10.2	17.8	118	56.8	55.8	35 ⁰ _{-0.016}	58
NS 2525A	15.2	25.8	210	105	103	42 ⁰ _{-0.016}	65
NS 3232A	20.5	34	290	180	157	49 ⁰ _{-0.016}	77
NS 4040A	37.8	60.5	687	418	377	64 ⁰ _{-0.019}	100

Note) For K hollow shaft, please refer to the db dimension for the inner bore diameter of the shaft. If requested solid shaft is also available. See "Ball Spline" **A3-112** for details.

Model number coding

NS2020A +500L

Model number Overall shaft length (in mm)

Precision Ball Screw/Spline

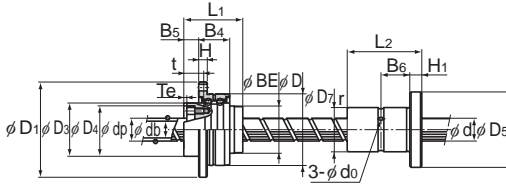

Ball screw unit (Models NS 1616A to 4040A) Ball spline (Models NS 1616A to 4040A)

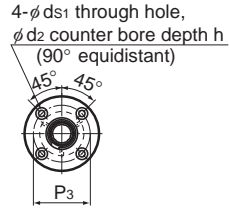

Ball spline (Models NS 1616A to 4040A)

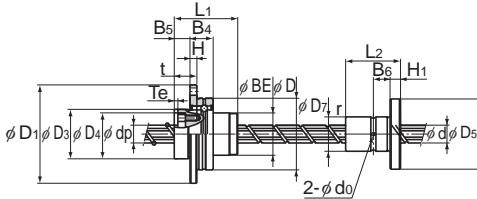

Ball screw unit (Models NS 0812A and 1015A) Ball spline (Models NS 0812A and 1015A)

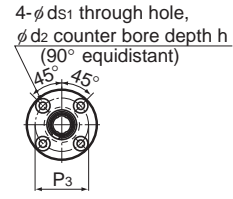

Ball spline (Models NS 0812A and 1015A)

Unit: mm

	BE	H	B ₄	B ₅	T _e	P ₁	P ₂	S	t	d ₁	Support bearing basic load rating		Nut inertial moment	Screw shaft inertial moment/mm	Nut mass	Shaft mass
											C _a	C _{0a}				
											kN	kN	kg-cm ²	J kg-cm ² /mm	kg	kg/m
	19	3	10.5	7	1.5	38	14.5	M2.6	10	3.4	0.8	0.5	0.03	3.16 × 10 ⁻⁵	0.08	0.35
	23	3	10.5	8	1.5	42	18	M3	11.5	3.4	0.9	0.7	0.08	7.71 × 10 ⁻⁵	0.15	0.52
	32	6	21	10	2	56	25	M4	13.5	4.5	8.7	10.5	0.35	3.92 × 10 ⁻⁴	0.31	0.8
	39	6	21	11	2.5	64	31	M5	16.5	4.5	9.7	13.4	0.85	9.37 × 10 ⁻⁴	0.54	1.21
	47	7	25	13	3	75	38	M6	20	5.5	12.7	18.2	2.12	2.2 × 10 ⁻³	0.88	1.79
	58	8	25	14	3	89	48	M6	21	6.6	13.6	22.3	5.42	5.92 × 10 ⁻³	1.39	2.96
	73	10	33	16.5	3	113	61	M8	24.5	9	21.5	36.8	17.2	1.43 × 10 ⁻²	3.16	4.51

Unit: mm

Overall length	H ₁	B ₆	r	Greasing hole	d ₀	P ₃	Mounting hole			Nut mass
							d _{s1}	d ₂	h	
L ₂									kg	
25	5	7.5	0.5	1.5	1.5	24	3.4	6.5	3.3	0.04
33	6	10.5	0.5	1.5	1.5	32	4.5	8	4.4	0.09
50 ^{-0.2}	7	18	0.5	2	2	40	4.5	8	4.4	0.23
63 ^{-0.2}	9	22.5	0.5	2	2	45	5.5	9.5	5.4	0.33
71 ^{-0.3}	9	26.5	0.5	3	3	52	5.5	9.5	5.4	0.45
80 ^{-0.3}	10	30	0.5	3	3	62	6.6	11	6.5	0.58
100 ^{-0.3}	14	36	0.5	4	4	82	9	14	8.6	1.46

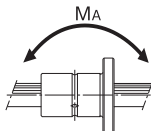

NS Heavy Load Type: Linear Motion No Preload

DN value	70000
----------	-------

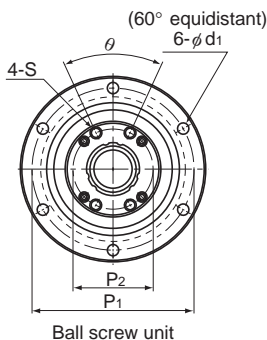

Ball screw unit

Model No.	Screw shaft outer diameter d	Screw shaft inner diameter db	Lead Ph	Ball screw dimensions							
				Basic load rating		Ball center-to-center diameter dp	Thread minor diameter dc	Outer diameter D	Flange diameter D ₁	Overall length L ₁	D ₃ h7
				Ca kN	C _{0a} kN						
NS 1616	16	11	16	3.9	7.2	16.65	13.7	52 ⁰ _{-0.007}	68	43.5	40
NS 2020	20	14	20	6.1	12.3	20.75	17.5	62 ⁰ _{-0.007}	78	54	50
NS 2525	25	18	25	9.1	19.3	26	21.9	72 ⁰ _{-0.007}	92	65	58
NS 3232	32	23	32	13	29.8	33.25	28.3	80 ⁰ _{-0.007}	105	80	66
NS 4040	40	29	40	21.4	49.7	41.75	35.2	110 ⁰ _{-0.008}	140	98	90
NS 5050	50	36	50	31.8	77.6	52.2	44.1	120 ⁰ _{-0.008}	156	126	100

Ball spline

Model No.	Ball spline dimensions					
	Basic load rating		Static permissible moment M _k N-m	Basic torque rating		Outer diameter D ₇
	C kN	C ₀ kN		C _T N-m	C _{0T} N-m	
NS 1616	7.1	12.6	67.6	31.4	34.3	31 ⁰ _{-0.013}
NS 2020	10.2	17.8	118	56.9	55.9	35 ⁰ _{-0.016}
NS 2525	15.2	25.8	210	105	103	42 ⁰ _{-0.016}
NS 3232	20.5	34	290	180	157	49 ⁰ _{-0.016}
NS 4040	37.8	60.5	687	419	377	64 ⁰ _{-0.019}
NS 5050	60.9	94.5	1340	842	769	80 ⁰ _{-0.019}

Note) For K hollow shaft, please refer to the db dimension for the inner bore diameter of the shaft. If requested solid shaft is also available. See "Ball Spline" **A3-112** for details.

Model number coding

NS2525 +600L

Model number Overall shaft length (in mm)

Precision Ball Screw/Spline

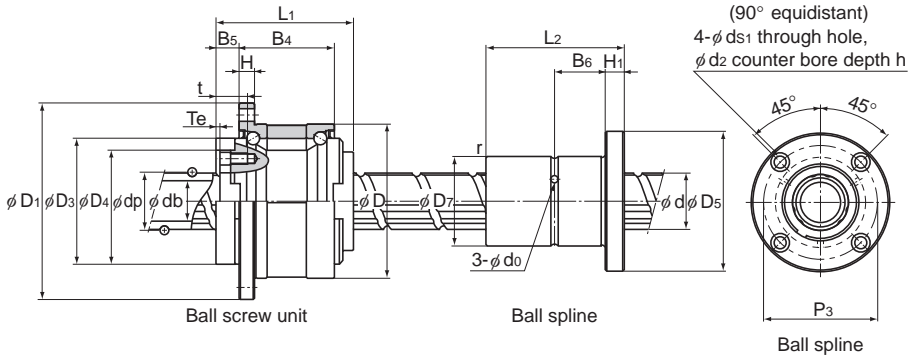

Unit: mm

D ₄	H7	H	B ₄	B ₅	T _e	P ₁	P ₂	S	t	d ₁	θ°	Support bearing basic load rating		Nut inertial moment	Screw shaft inertial moment/mm	Nut mass	Shaft mass
												C _a	C _{0a}				
32	5	27.5	9	2	60	25	M4	12	4.5	40	19.4	19.2	0.48	3.92×10^{-4}	0.38	0.8	
39	6	34	11	2	70	31	M5	16	4.5	40	26.8	29.3	1.44	9.37×10^{-4}	0.68	1.21	
47	8	43	12.5	3	81	38	M6	19	5.5	40	28.2	33.3	3.23	2.2×10^{-3}	1.1	1.79	
58	9	55	14	3	91	48	M6	19	6.6	40	30	39	6.74	5.92×10^{-3}	1.74	2.96	
73	11	68	16.5	3	123	61	M8	22	9	50	59.3	74.1	27.9	1.43×10^{-2}	3.95	4.51	
90	12	80	25	4	136	75	M10	28	11	50	62.2	83	58.2	3.52×10^{-2}	6.22	7.16	

Unit: mm

Flange diameter	Overall length	H ₁	B ₆	r	Greasing hole	d ₀	P ₃	Mounting hole			Nut mass
								d _{s1}	d ₂	h	
D ₅	L ₂							d _{s1}	d ₂	h	kg
51	50 ⁰ _{-0.2}	7	18	0.5	2	40	4.5	8	4.4	0.23	
58	63 ⁰ _{-0.2}	9	22.5	0.5	2	45	5.5	9.5	5.4	0.33	
65	71 ⁰ _{-0.3}	9	26.5	0.5	3	52	5.5	9.5	5.4	0.45	
77	80 ⁰ _{-0.3}	10	30	0.5	3	62	6.6	11	6.5	0.58	
100	100 ⁰ _{-0.3}	14	36	0.5	4	82	9	14	8.6	1.46	
124	125 ⁰ _{-0.3}	16	46.5	1	4	102	11	17.5	11	2.76	

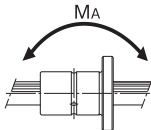

Rolled Ball Screw

Models JPF, BTK-V, MTF, WHF, BLK/WTF, CNF and BNT

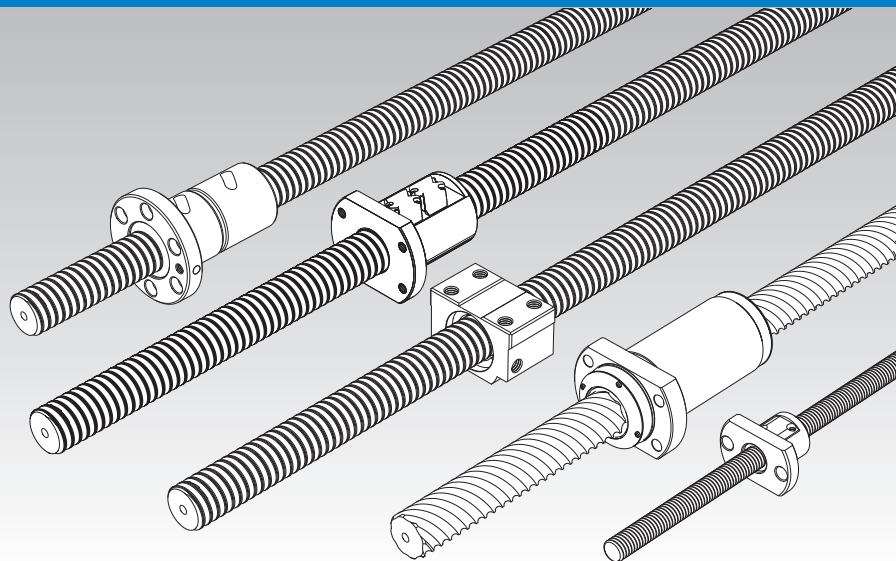

Point of Selection **A15-8**

Options **A15-336**

Model No. **A15-353**

Precautions on Use **A15-358**

Accessories for Lubrication **A24-1**

Mounting Procedure and Maintenance **B15-104**

Lead Angle Accuracy **A15-11**

Accuracy of the Mounting Surface **A15-14**

Axial Clearance **A15-19**

Maximum Length of the Screw Shaft **A15-24**

DN Value **A15-33**

Support Unit **A15-300**

Recommended Shapes of Shaft Ends **A15-308**

Dimensions of Each Model with an Option Attached **A15-344**

Structure and Features

THK Rolled Ball Screws are low priced feed screws that use a screw shaft rolled with high accuracy and specially surface-ground, instead of a thread-ground shaft used in the Precision Ball Screws. The ball raceways of the ball screw nut are all thread-ground, thus to achieve a smaller axial clearance and smoother motion than the conventional rolled ball screw.

In addition, a wide array of types are offered as standard in order to allow optimal products to be selected according to the application.

[Achieves Lead Angle Accuracy of Class C7]

Screw shafts with travel distance error of classes C7 and C8 are also manufactured as the standard in addition to class C10 to meet a broad range of applications.

Travel distance	C7 : $\pm 0.05/300$ (mm)
	C8 : $\pm 0.10/300$ (mm)
	C10 : $\pm 0.21/300$ (mm)

(For maximum length of screw shaft by accuracy grade, see **A15-25**.)

[Achieves Roughness of the Ball Raceways of the Screw Shaft at 0.20 a or Less]

The surface of the screw shaft's ball raceways is specially ground after the shaft is rolled to ensure surface roughness of 0.20 a or less, which is equal to that of the ground thread of the Precision Ball Screw.

[The Ball Raceways of the Ball Screw Nut are Finished by Grinding]

THK finishes the ball raceways of Rolled Ball Screw nuts by grinding, just as the Precision Ball Screws, to secure the durability and the smooth motion.

[Low Price]

The screw shaft is induction-hardened or carburized after being rolled, and its surface is then specially ground. This allows the rolled Ball Screw to be priced lower than the Precision Ball Screw with a ground thread.

[Effects of high levels of dustproofing]

The ball screw nut is incorporated with a compact labyrinth seal or a brush seal. This achieves low friction, high dust-prevention effect and a longer service life of the Ball Screw.

Types and Features

[Preload Type]

Model JPF

Specification Table⇒ **A15-270**

This model achieves zero-backlash through a constant preloading method by shifting the phase, with the central part of the nut as a spring structure.

The constant preload method allows the ball screw to absorb a pitch error and achieve a smooth motion.

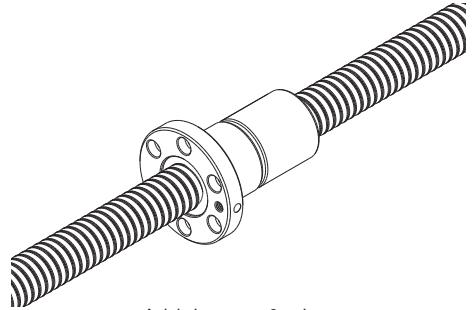

Axial clearance: 0 or less

● Direction of applied load

The direction of the applied load during use must be in the recommended loading direction indicated in the figure. If a load is applied in the opposite direction, it may cause the spring structure to fracture, and therefore, the applied load must be $0.1 \times C_a$ or less during use.

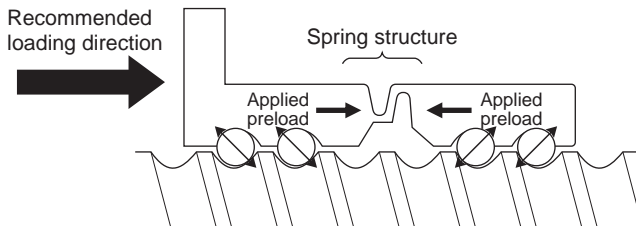

[No Preload Type]

Model BTK-V

Specification Table⇒ **A15-272**

This Rolled Ball Screw feed achieves a DN value of 100,000 by using a new circulation structure.

Since the nut outer diameter and the mounting holes of this model are dimensionally interchangeable with the previous model BTK, model BTK can be replaced with this model.

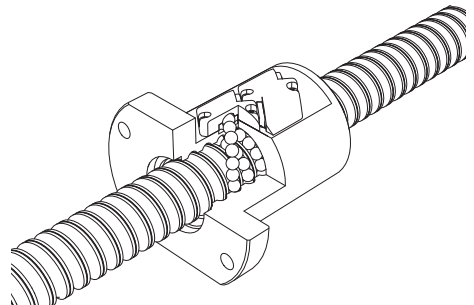

Model MTF

A miniature type with a screw shaft diameter of $\phi 6$ to $\phi 12$ mm and a lead of 1 to 2 mm.

Specification Table \Rightarrow **A15-274**

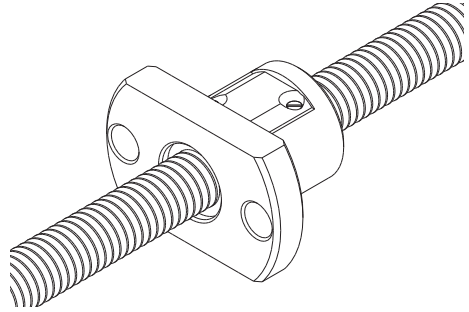

Model WHF

This Ball Screw for high-speed feed achieves a DN value of 100,000 by using a new circulation structure.

Since the nut outer diameter and the mounting holes of this model are dimensionally interchangeable with the previous model WTF, model WTF can be replaced with this model. (WHF1530, WHF2040 and WHF2550)

Specification Table \Rightarrow **A15-275**

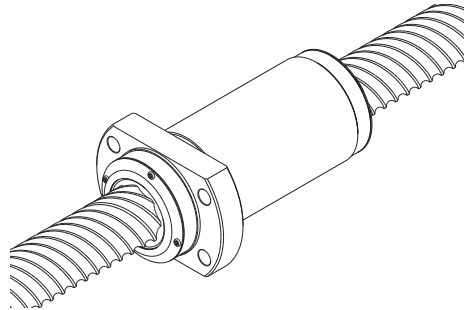

Models BLK/WTF

Using an end-cap method, these models achieve stable motion in a high-speed rotation.

Specification Table \Rightarrow **A15-276**

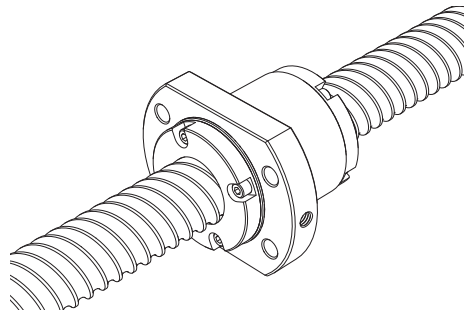

Model CNF

Specification Table⇒ **A15-282**

With a combination of 4 rows of large-lead load-
ed grooves and a long nut, a long service life is
achieved.

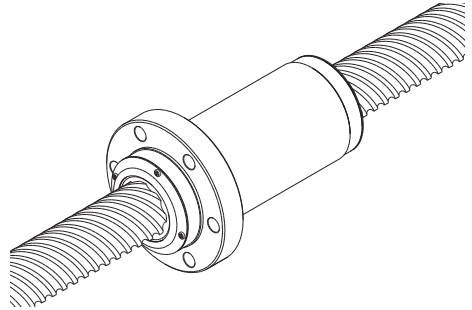

Square Ball Screw Nut Model BNT

Specification Table⇒ **A15-280**

Since the mounting screw holes are machined
on the square ball screw nut, this model can
compactly be mounted on the machine without
a housing.

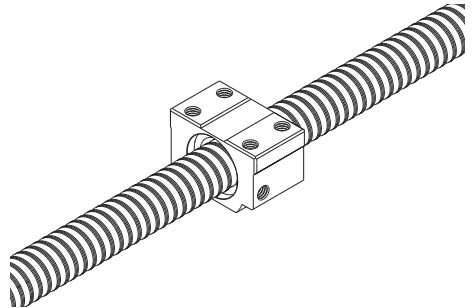

JPF With Preload

DN value	50000
----------	-------

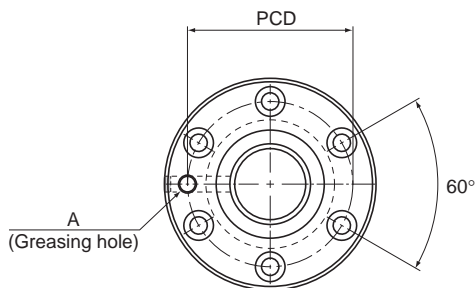

Model No.	Screw shaft outer diameter d	Lead Ph	Ball center-to-center diameter dp	Thread minor diameter dc	No. of loaded circuits Rows X turns	Basic load rating		Outer diameter D	Flange diameter D ₁	Outer diameter D ₂
						C _a kN	C _{0a} kN			
JPF 1404-4	14	4	14.4	11.5	2×1	2.8	5.1	26	46	25.5
JPF 1405-4		5	14.5	11.2	2×1	3.9	8.6	26	46	25.5
JPF 1605-4	16	5	16.75	13.5	2×1	3.7	8.2	30	49	29.5
JPF 2005-6	20	5	20.5	17.2	3×1	6	16	34	57	33.5
JPF 2505-6	25	5	25.5	22.2	3×1	6.9	20.8	40	66	39.5
JPF 2510-4		10	26.8	20.2	2×1	11.4	24.5	47	72	46.5
JPF 2805-6	28	5	28.75	25.2	3×1	7.3	23.9	43	69	42.5
JPF 2806-6		6	28.5	25.2	3×1	7.3	23.9	43	69	42.5
JPF 3210-6	32	10	33.75	27.2	3×1	19.3	49.9	54	88	53.5
JPF 3610-6	36	10	37	30.5	3×1	20.6	56.2	58	98	57.5
JPF 4010-6	40	10	41.75	35.2	3×1	22.2	65.3	62	104	61.5

Model number coding

JPF1404-4 RR G0 +500L C7 T

Model No.

Seal symbol (*1)

Overall screw shaft length (in mm)

Symbol for rolled shaft

Symbol for clearance in the axial direction

Accuracy symbol (*2)

(*1) See [A15-336](#). (*2) See [A15-12](#).

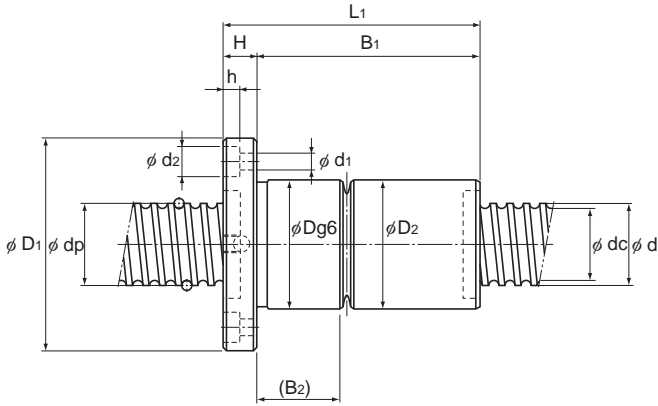

Unit: mm

Nut dimensions								Screw shaft inertial moment/mm ² kg-cm ² /mm	Nut mass kg	Shaft mass kg/m
Overall length	H	B ₁	B ₂	PCD	d ₁ × d ₂ × h	Greasing hole				
L ₁						A				
52	10	42	16.5	36	4.5 × 8 × 4.5	M6	2.96 × 10 ⁻⁴	0.22	1	
60	10	50	20	36	4.5 × 8 × 4.5	M6	2.96 × 10 ⁻⁴	0.24	0.99	
60	10	50	19.5	39	4.5 × 8 × 4.5	M6	5.05 × 10 ⁻⁴	0.3	1.34	
80	11	69	26.5	45	5.5 × 9.5 × 5.5	M6	1.23 × 10 ⁻³	0.46	2.15	
80	11	69	26	51	5.5 × 9.5 × 5.5	M6	3.01 × 10 ⁻³	0.6	3.45	
112	12	100	42	58	6.6 × 11 × 6.5	M6	3.01 × 10 ⁻³	1.2	3.26	
80	12	68	25	55	6.6 × 11 × 6.5	M6	4.74 × 10 ⁻³	0.66	4.27	
90	12	78	35	55	6.6 × 11 × 6.5	M6	4.74 × 10 ⁻³	0.72	4.44	
135	15	120	53.5	70	9 × 14 × 8.5	M6	8.08 × 10 ⁻³	1.84	5.49	
138	18	120	53.5	77	11 × 17.5 × 11	M6	1.29 × 10 ⁻²	2.22	6.91	
138	18	120	53.5	82	11 × 17.5 × 11	R1/8 (PT1/8)	1.97 × 10 ⁻²	2.42	8.81	

Note) The ball screw nut and the screw shaft of model JPF are not sold separately.

The basic load rating corresponds to the recommended loading direction.

If a load is applied in the opposite direction, the value must be 0.1 × C_a or less during use (see **A15-266**).

BTK-V

No Preload

DN value	100000
----------	--------

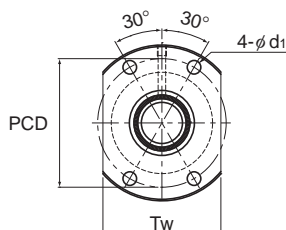

Model No.	Screw shaft outer diameter d	Lead Ph	Ball center-to-center diameter dp	Thread minor diameter dc	No. of loaded circuits Rows X turns	Basic load rating		Rigidity K	Outer diameter D	Flange diameter D ₁	Overall length	
						Ca	C _{0a}				L ₁	H
						kN	kN	N/μm				
BTK 1006V-2.6	10	6	10.5	7.8	1×2.65	2.8	4.9	88	26	42	36	8
BTK 1208V-2.6	12	8	12.65	9.7	1×2.65	3.8	6.8	108	29	45	44	8
BTK 1404V-3.6	14	4	14.4	11.5	1×3.65	5.5	11.5	150	31	50	40	10
BTK 1405V-2.6	14	5	14.5	11.2	1×2.65	5	11.4	116	32	50	40	10
BTK 1605V-2.6	16	5	16.75	13.5	1×2.65	5.4	13.3	130	34	54	40	10
BTK 1808V-3.6	18	8	19.3	14.4	1×3.65	13.1	31	210	50	80	61	12
BTK 2005V-2.6	20	5	20.5	17.2	1×2.65	6	16.5	150	40	60	40	10
BTK 2010V-2.6	20	10	21.25	16.4	1×2.65	10.6	25.1	160	52	82	61	12
BTK 2505V-2.6	25	5	25.5	22.2	1×2.65	6.7	20.8	180	43	67	40	10
BTK 2510V-5.3	25	10	26.8	20.2	2×2.65	31.2	83.7	400	60	96	98	15
BTK 2806V-2.6	28	6	28.5	25.2	1×2.65	7	23.4	200	50	80	47	12
BTK 2806V-5.3	28	6	28.5	25.2	2×2.65	12.8	46.8	390	50	80	65	12
BTK 3210V-2.6	32	10	33.75	27.2	1×2.65	19.8	53.8	250	67	103	68	15
BTK 3210V-5.3	32	10	33.75	27.2	2×2.65	36	107.5	490	67	103	98	15
BTK 3610V-2.6	36	10	37	30.5	1×2.65	20.8	59.8	270	70	110	70	17
BTK 3610V-5.3	36	10	37	30.5	2×2.65	37.8	118.7	530	70	110	100	17
BTK 4010V-5.3	40	10	41.75	35.2	2×2.65	40.3	134.9	590	76	116	100	17
BTK 4512V-5.3	45	12	46.5	39.2	2×2.65	49.5	169	650	82	128	118	20
BTK 5016V-5.3	50	16	52.7	42.9	2×2.65	93.8	315.2	930	102	162	145	25

Model number coding

BTK1405V-2.6 ZZ +500L C7 T H1K

Model No.

Contamination protection accessory symbol (*1)

Overall screw shaft length (in mm)

Symbol for rolled shaft

Accuracy symbol (*2)

Recommended shaft ends shape code

(*1) See [A15-336](#). (*2) See [A15-12](#).

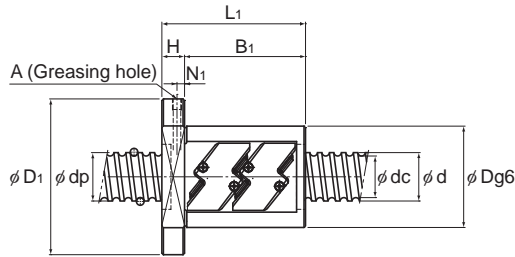

Unit: mm

Nut dimensions						Axial clearance	Standard shaft length	Screw shaft inertial moment/mm kg-cm ² /mm	Nut mass kg	Shaft mass kg/m
B ₁	PCD	d ₁	Tw	Greasing hole						
				N ₁	A					
28	34	4.5	29	—	3	0.05	200, 300, 500, 1000	7.71×10^{-5}	0.12	0.48
36	37	4.5	32	—	3	0.05	200, 300, 500, 1000	1.6×10^{-4}	0.18	0.72
30	40	4.5	37	5	M6	0.1	500, 1000	2.96×10^{-4}	0.23	1
30	40	4.5	38	5	M6	0.1	500, 1000	2.96×10^{-4}	0.22	0.99
30	44	4.5	40	5	M6	0.1	500, 1000, 1500	5.05×10^{-4}	0.24	1.34
49	65	6.6	60	5	M6	0.1	500, 1000, 1500	8.09×10^{-4}	0.84	1.71
30	50	4.5	46	5	M6	0.1	500, 1000, 1500, 2000	1.23×10^{-3}	0.32	2.15
49	67	6.6	64	5	M6	0.1	500, 1000, 1500, 2000	1.23×10^{-3}	0.93	2.16
30	55	5.5	50	5	M6	0.1	500, 1000, 1500, 2000	3.01×10^{-3}	0.34	3.45
83	78	9	72	5	M6	0.1	500, 1000, 1500, 2000	3.01×10^{-3}	1.83	3.26
35	65	6.6	60	6	M6	0.1	500, 1000, 2000, 2500	4.74×10^{-3}	0.59	4.44
53	65	6.6	60	6	M6	0.1	500, 1000, 2000, 2500	4.74×10^{-3}	0.75	4.44
53	85	9	78	5	M6	0.14	500, 1000, 1500, 2000, 2500, 3000	8.08×10^{-3}	1.56	5.49
83	85	9	78	5	M6	0.14	500, 1000, 1500, 2000, 2500, 3000	8.08×10^{-3}	2.1	5.49
53	90	11	82	7	M6	0.17	500, 1000, 2000, 2500, 3000	1.29×10^{-2}	1.78	6.91
83	90	11	82	7	M6	0.17	500, 1000, 2000, 2500, 3000	1.29×10^{-2}	2.35	6.91
83	96	11	88	7	M6	0.17	1000, 1500, 2000, 2500, 3000, 3500	1.97×10^{-2}	2.6	8.81
98	104	14	94	8	M6	0.17	1000, 1500, 2000, 3000, 3500, 4000	3.16×10^{-2}	3.48	11.08
120	132	18	104	12.5	R1/8 (PT1/8)	0.2	1000, 1500, 2000, 3000, 3500, 4000	4.82×10^{-2}	6.52	13.66

Note) The overall length of the nut will increase when equipping the QZ lubricating device. See **A15-344** for further details.

MTF No Preload

DN value	5000
----------	------

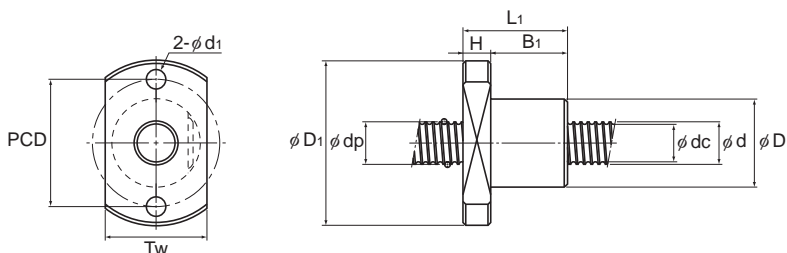

Unit: mm

Model No.	Screw shaft outer diameter d	Lead Ph	Ball center-to-center diameter dp	Thread minor diameter dc	No. of loaded circuits Rows X turns	Basic load rating		Rigidity K N/μm	Nut dimensions		
						Ca kN	Ca kN		Outer diameter D	Flange diameter D ₁	Overall length L ₁
MTF 0601-3.7	6	1	6.15	5.3	1×3.7	0.7	1.2	70	13	30	21
MTF 0802-3.7	8	2	8.3	6.6	1×3.7	2.1	3.8	90	20	40	28
MTF 1002-3.7	10	2	10.3	8.6	1×3.7	2.3	4.8	110	23	43	28
MTF 1202-3.7	12	2	12.3	10.6	1×3.7	2.5	5.8	130	25	47	30

Model No.	Nut dimensions					Axial clearance	Standard shaft length	Screw shaft inertial moment/mm kg-cm ² /mm	Nut mass kg	Shaft mass kg/m
	H	B ₁	PCD	d ₁	Tw					
MTF 0601-3.7	5	16	21.5	3.4	17	0.05	150, 250	9.99×10 ⁻⁶	0.03	0.19
MTF 0802-3.7	6	22	30	4.5	24	0.05	150, 250	3.16×10 ⁻⁵	0.08	0.31
MTF 1002-3.7	6	22	33	4.5	27	0.05	200, 300	7.71×10 ⁻⁵	0.1	0.52
MTF 1202-3.7	8	22	36	5.5	29	0.05	200, 300	1.6×10 ⁻⁴	0.13	0.77

Note) Model MTF cannot be attached with seal.

Model MTF is only sold as sets (ball screw nut and screw shaft).

Model MTF is applied only with anti-rust oil.

Model number coding

MTF 0802-3.7 +250L C7 T

Model No.

Overall screw shaft length (in mm)

Symbol for rolled shaft

Accuracy code: (No code for Normal Grade)

WHF (Rolled Ball Screw) No Preload

DN value	100000
----------	--------

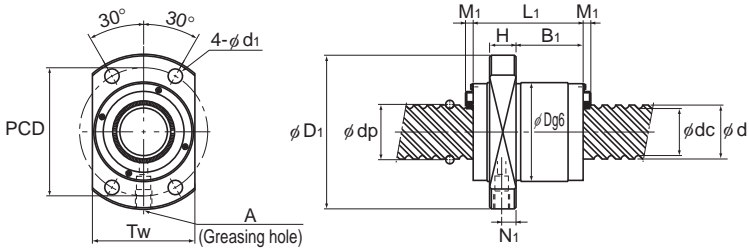

Unit: mm

Model No.	Screw shaft outer diameter d	Lead Ph	Ball center-to-center diameter dp	Thread minor diameter dc	No. of loaded circuits Rows × turns	Basic load rating		Rigidity K	Nut dimensions				
						Ca	C _{0a}		Outer diameter D	Flange diameter D ₁	Overall length L ₁	H	B ₁
						kN	kN	N/μm					
WHF 1530-3.4	15	30	15.75	12.5	2×1.7	5.5	12.2	195	32	53	64.5	10	47.5
WHF 2020-3.4	20	20	20.75	17.5	2×1.7	6.6	18.9	225	42	64	47.1	10	24.1
WHF 2040-3.4	20	40	20.75	17.5	2×1.7	6.6	17.2	256	37	62	82.7	10	65.7
WHF 2525-3.4	25	25	26	21.9	2×1.7	10.5	29.9	285	50	77	58.8	12	31.3
WHF 2550-3.4	25	50	26	21.9	2×1.7	10.4	27.1	323	45	69	103.3	12	79.3

Model No.	Nut dimensions					Seal M ₁	Axial clearance	Standard shaft length	Screw shaft inertial moment/mm ²	Nut mass kg	Shaft mass kg/m
	PCD	d ₁	Tw	Greasing hole							
				N ₁	A						
WHF 1530-3.4	43	5.5	33	5	M6	3.5	0.1	500, 1000, 1500	3.9×10 ⁻⁴	0.38	1.26
WHF 2020-3.4	53	5.5	46	5	M6	3.5	0.1	500, 1000, 1500	1.23×10 ⁻³	0.49	2.25
WHF 2040-3.4	50	5.5	46	5	M6	3.5	0.1	500, 1000, 1500, 2000	1.23×10 ⁻³	0.58	2.34
WHF 2525-3.4	63	6.6	56	6	M6	3.5	0.1	1000, 1500, 2000	3.01×10 ⁻³	0.65	3.52
WHF 2550-3.4	57	6.6	46	6	M6	3.5	0.1	1000, 1500, 2000	3.01×10 ⁻³	0.72	3.66

Note) WHF is available on a made-to-order basis. If planning to use this model, contact THK.

The overall length of the nut will increase when equipping the QZ lubricating device. See [A15-344](#) for further details.

Model number coding

WHF2040-3.4 -ZZ +1500L C7 T T1K

Model No.

Contamination protection accessory symbol (*1)

Overall screw shaft length (in mm)

Symbol for rolled shaft

Accuracy symbol (*2) Recommended shaft ends shape code

(*1) See [A15-336](#). (*2) See [A15-12](#).

BLK (Rolled Ball Screw) No Preload

DN value	70000
----------	-------

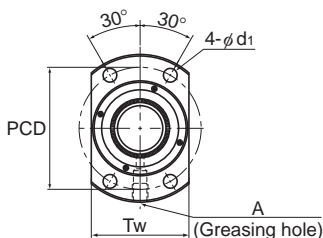

Model No.	Screw shaft outer diameter d	Lead Ph	Ball center-to-center diameter dp	Thread minor diameter dc	No. of loaded circuits Rows X turns	Basic load rating		Rigidity K	Outer diameter D	Flange diameter D ₁	Overall length L ₁	H
						Ca kN	C _{0a} kN					
BLK 1510-5.6	15	10	15.75	12.5	2×2.8	9.8	25.2	260	34	57	44	10
BLK 1616-3.6	16	16	16.65	13.7	2×1.8	5.8	12.9	170	32	53	38	10
BLK 1616-7.2	16	16	16.65	13.7	4×1.8	10.5	25.9	340	32	53	38	10
BLK 2020-3.6	20	20	20.75	17.5	2×1.8	7.7	22.3	210	39	62	45	10
BLK 2020-7.2	20	20	20.75	17.5	4×1.8	13.9	44.6	410	39	62	45	10
BLK 2525-3.6	25	25	26	21.9	2×1.8	12.1	35	270	47	74	55	12
BLK 2525-7.2	25	25	26	21.9	4×1.8	21.9	69.9	520	47	74	55	12
BLK 3232-3.6	32	32	33.25	28.3	2×1.8	17.3	53.9	330	58	92	70	15
BLK 3232-7.2	32	32	33.25	28.3	4×1.8	31.3	107.8	650	58	92	70	15
BLK 3620-5.6	36	20	37.75	31.2	2×2.8	39.8	121.7	570	70	110	78	17
BLK 3624-5.6	36	24	38	30.7	2×2.8	46.2	137.4	590	75	115	94	18
BLK 3636-3.6	36	36	37.4	31.7	2×1.8	22.4	70.5	370	66	106	77	17
BLK 3636-7.2	36	36	37.4	31.7	4×1.8	40.6	141.1	730	66	106	77	17
BLK 4040-3.6	40	40	41.75	35.2	2×1.8	28.1	89.8	420	73	114	85	17
BLK 4040-7.2	40	40	41.75	35.2	4×1.8	51.1	179.6	810	73	114	85	17
BLK 5050-3.6	50	50	52.2	44.1	2×1.8	42.1	140.4	510	90	135	106	20
BLK 5050-7.2	50	50	52.2	44.1	4×1.8	76.3	280.7	1000	90	135	106	20

Model number coding

BLK3232-3.6 ZZ +1500L C7 T H1K

Model No.

Contamination protection accessory symbol (*1)

Overall screw shaft length (in mm)

Symbol for rolled shaft

Accuracy symbol (*2)

Recommended shaft ends shape code

(*1) See **A15-336**. (*2) See **A15-12**.

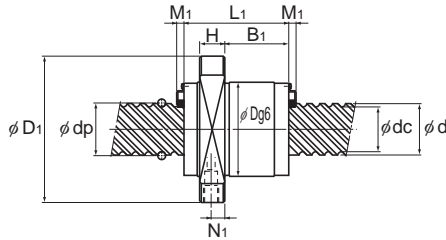

Unit: mm

Nut dimensions								Axial clearance	Standard shaft length	Screw shaft inertial moment/mm kg-cm ² /mm	Nut mass kg	Shaft mass kg/m
B ₁	PCD	d ₁	T _w	Greasing hole		Seal M ₁						
				N ₁	A							
24	45	5.5	40	5	M6	3.5	0.1	500, 1000	3.9×10^{-4}	0.26	1.16	
21.5	42	4.5	38	5	M6	3.5	0.1	500, 1000, 1500	5.05×10^{-4}	0.21	1.35	
21.5	42	4.5	38	5	M6	3.5	0.1	500, 1000, 1500	5.05×10^{-4}	0.25	1.35	
27.5	50	5.5	46	5	M6	3.5	0.1	500, 1000, 1500	1.23×10^{-3}	0.35	2.18	
27.5	50	5.5	46	5	M6	3.5	0.1	500, 1000, 1500	1.23×10^{-3}	0.35	2.18	
35	60	6.6	56	6	M6	3.5	0.1	500, 1000, 1500, 2000, 2500	3.01×10^{-3}	0.64	3.41	
35	60	6.6	56	6	M6	3.5	0.1	500, 1000, 1500, 2000, 2500	3.01×10^{-3}	0.64	3.41	
45	74	9	68	7.5	M6	3.8	0.14	1000, 1500, 2000, 2500, 3000	8.08×10^{-3}	1.14	5.69	
45	74	9	68	7.5	M6	3.8	0.14	1000, 1500, 2000, 2500, 3000	8.08×10^{-3}	1.14	5.69	
45	90	11	80	8.5	M6	5	0.17	1000, 1500, 2000, 2500, 3000	1.29×10^{-2}	1.74	7.09	
59	94	11	86	9	M6	5	0.17	1000, 1500, 2000, 2500, 3000	1.29×10^{-2}	2.42	7.02	
50	85	11	76	8.5	M6	5	0.17	1000, 1500, 2000, 2500, 3000	1.29×10^{-2}	1.74	7.12	
50	85	11	76	8.5	M6	5	0.17	1000, 1500, 2000, 2500, 3000	1.29×10^{-2}	1.74	7.12	
56.5	93	11	84	8.5	M6	5.4	0.17	1000, 1500, 2000, 2500, 3000, 4000	1.97×10^{-2}	2.16	8.76	
56.5	93	11	84	8.5	M6	5.4	0.17	1000, 1500, 2000, 2500, 3000, 4000	1.97×10^{-2}	2.16	8.76	
72	112	14	104	10	M6	5.4	0.2	1000, 1500, 2000, 3000, 4000	4.82×10^{-2}	3.89	13.79	
72	112	14	104	10	M6	5.4	0.2	1000, 1500, 2000, 3000, 4000	4.82×10^{-2}	3.86	13.79	

Note) The overall length of the nut will increase when equipping the QZ lubricating device. See **A15-344** for further details.

WTF No Preload

DN value	70000
----------	-------

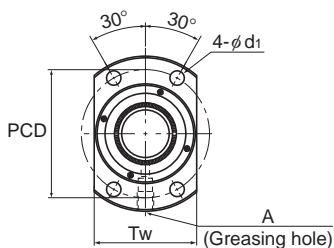

Model No.	Screw shaft outer diameter d	Lead Ph	Ball center-to-center diameter dp	Thread minor diameter dc	No. of loaded circuits Rows X turns	Basic load rating		Rigidity K	Outer diameter D	Flange diameter D ₁	Overall length L ₁	H
						Ca	C _{0a}					
						kN	kN	N/μm				
WTF 1520-3	15	20	15.75	12.5	2X1.5	5.5	14.2	140	32	53	45	10
WTF 1520-6	15	20	15.75	12.5	4X1.5	10.1	28.5	280	32	53	45	10
WTF 1530-2	15	30	15.75	12.5	4X0.6	4.3	9.3	120	32	53	33	10
WTF 1530-3	15	30	15.75	12.5	2X1.6	5.6	12.4	160	32	53	63	10
WTF 2040-2	20	40	20.75	17.5	4X0.65	5.4	13.6	160	37	57	41.5	10
WTF 2040-3	20	40	20.75	17.5	2X1.65	6.6	17.2	200	37	57	81.5	10
WTF 2550-2	25	50	26	21.9	4X0.65	8.5	21.2	200	45	69	52	12
WTF 2550-3	25	50	26	21.9	2X1.65	10.4	26.9	260	45	69	102	12
WTF 3060-2	30	60	31.25	26.4	4X0.65	11.8	30.6	240	55	89	62.5	15
WTF 3060-3	30	60	31.25	26.4	2X1.65	14.5	38.9	310	55	89	122.5	15
WTF 4080-2	40	80	41.75	35.2	4X0.65	19.8	54.5	320	73	114	79	17
WTF 4080-3	40	80	41.75	35.2	2X1.65	24.3	69.2	400	73	114	159	17
WTF 50100-2	50	100	52.2	44.1	4X0.65	29.6	85.2	390	90	135	98	20
WTF 50100-3	50	100	52.2	44.1	2X1.65	36.3	108.1	500	90	135	198	20

Model number coding

WTF3060-3 ZZ +1500L C7 T H1K

Model No.	Contamination protection accessory symbol (*)	Overall screw shaft length (in mm)	Symbol for rolled shaft	Accuracy symbol (*)	Recommended shaft ends shape code
-----------	---	------------------------------------	-------------------------	---------------------	-----------------------------------

(*) See **A15-336**. (*) See **A15-12**.

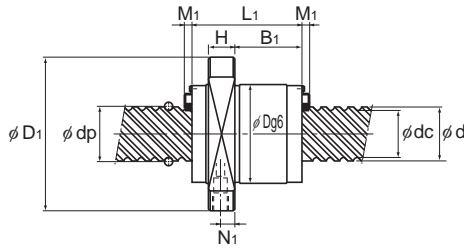

Unit: mm

Nut dimensions							Seal	Axial clearance	Standard shaft length	Screw shaft inertial moment/mm kg-cm ² /mm	Nut mass kg	Shaft mass kg/m
B ₁	PCD	d ₁	Tw	Greasing hole		M ₁						
				N ₁	A							
28	43	5.5	33	5	M6	3.5	0.1	500, 1000	3.9×10^{-4}	0.2	1.17	
28	43	5.5	33	5	M6	3.5	0.1	500, 1000	3.9×10^{-4}	0.2	1.17	
17	43	5.5	33	5	M6	3.5	0.1	500, 1000, 1500	3.9×10^{-4}	0.22	1.19	
47	43	5.5	33	5	M6	3.5	0.1	500, 1000, 1500	3.9×10^{-4}	0.4	1.19	
25.5	47	5.5	38	5.5	M6	3.5	0.1	500, 1000, 1500, 2000	1.23×10^{-3}	0.25	2.12	
65.5	47	5.5	38	5.5	M6	3.5	0.1	500, 1000, 1500, 2000	1.23×10^{-3}	0.5	2.12	
31.5	57	6.6	46	7	M6	3.5	0.1	1000, 1500, 2000, 3000	3.01×10^{-3}	0.45	3.34	
81.5	57	6.6	46	7	M6	3.5	0.1	1000, 1500, 2000, 3000	3.01×10^{-3}	0.85	3.34	
37.5	71	9	56	9	M6	3.8	0.14	1000, 2000, 3000, 4000	6.24×10^{-3}	0.8	4.84	
97.5	71	9	56	9	M6	3.8	0.14	1000, 2000, 3000, 4000	6.24×10^{-3}	1.7	4.84	
50.5	93	11	74	8.5	M6	5.4	0.17	1000, 1500, 2000, 3000	1.97×10^{-2}	2.1	8.66	
130.5	93	11	74	8.5	M6	5.4	0.17	1000, 1500, 2000, 3000	1.97×10^{-2}	3.67	8.66	
64	112	14	92	10	M6	5.4	0.2	1500, 3000	4.82×10^{-2}	3.5	13.86	
164	112	14	92	10	M6	5.4	0.2	1500, 3000	4.82×10^{-2}	6.4	13.86	

Note) The overall length of the nut will increase when equipping the QZ lubricating device. See **A15-344** for further details.

BNT (Rolled Ball Screw) No Preload

DN value	5000
----------	------

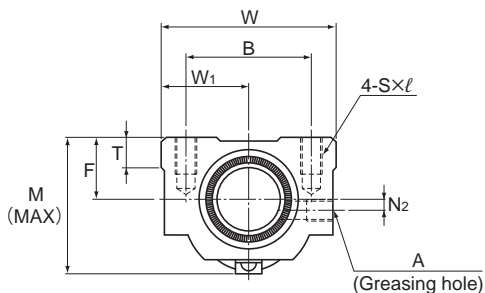

Model No.	Screw shaft outer diameter d	Lead Ph	Ball center-to-center diameter dp	Thread minor diameter dc	No. of loaded circuits Rows X turns	Basic load rating			Rigidity		
						Ca kN	C _{0a} kN	K N/μm	Width W	Center height F	Overall length L ₁
BNT 1404-3.6	14	4	14.4	11.5	1×3.65	5.5	11.5	150	34	13	35
BNT 1405-2.6		5	14.5	11.2	1×2.65	5	11.4	110	34	13	35
BNT 1605-2.6	16	5	16.75	13.5	1×2.65	5.4	13.3	130	42	16	36
BNT 1808-3.6	18	8	19.3	14.4	1×3.65	13.1	31	210	48	17	56
BNT 2005-2.6	20	5	20.5	17.2	1×2.65	6	16.5	150	48	17	35
BNT 2010-2.6		10	21.25	16.4	1×2.65	10.6	25.1	160	48	18	58
BNT 2505-2.6	25	5	25.5	22.2	1×2.65	6.7	20.8	180	60	20	35
BNT 2510-5.3		10	26.8	20.2	2×2.65	31.2	83.7	400	60	23	94
BNT 2806-2.6	28	6	28.5	25.2	1×2.65	7	23.4	200	60	22	42
BNT 2806-5.3			28.5	25.2	2×2.65	12.8	46.8	390	60	22	67
BNT 3210-2.6	32	10	33.75	27.2	1×2.65	19.8	53.8	250	70	26	64
BNT 3210-5.3			33.75	27.2	2×2.65	36	107.5	490	70	26	94
BNT 3610-2.6	36	10	37	30.5	1×2.65	20.8	59.3	270	86	29	64
BNT 3610-5.3			37	30.5	2×2.65	37.8	118.7	530	86	29	96
BNT 4512-5.3	45	12	46.5	39.2	2×2.65	49.5	169	650	100	36	115

Model number coding

BNT2010-2.6 ZZ +1000L C7 T H1K

Model No.	Contamination protection accessory symbol (*1)	Overall screw shaft length (in mm)	Accuracy symbol (*2)	Symbol for rolled shaft	Recommended shaft ends shape code
-----------	--	------------------------------------	----------------------	-------------------------	-----------------------------------

(*1) See **A15-336**. (*2) See **A15-12**.

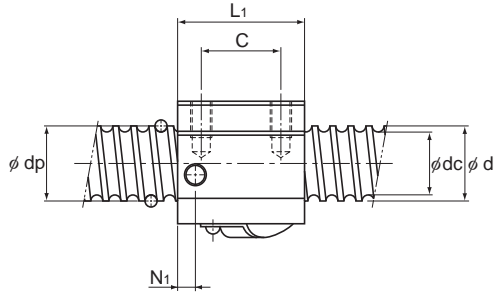

Unit: mm

Nut dimensions										Axial clearance	Screw shaft inertial moment/mm ² kg-cm ² /mm	Nut mass kg	Shaft mass kg/m
Mounting hole			W _i	T	M	N ₁	N ₂	A					
B	C	S×ℓ											
26	22	M4×7	17	6	30	6	2	M6	0.1	2.96×10 ⁻⁴	0.15	1	
26	22	M4×7	17	6	31	6	2	M6	0.1	2.96×10 ⁻⁴	0.15	0.99	
32	22	M5×8	21	21.5	32.5	6	2	M6	0.1	5.05×10 ⁻⁴	0.3	1.34	
35	35	M6×10	24	10	44	8	3	M6	0.1	8.09×10 ⁻⁴	0.47	1.71	
35	22	M6×10	24	9	39	5	3	M6	0.1	1.23×10 ⁻³	0.28	2.15	
35	35	M6×10	24	9	46	10	2	M6	0.1	1.23×10 ⁻³	0.5	2.16	
40	22	M8×12	30	9.5	45	7	5	M6	0.1	3.01×10 ⁻³	0.41	3.45	
40	60	M8×12	30	10	55	10	—	M6	0.1	3.01×10 ⁻³	1.18	3.26	
40	18	M8×12	30	10	50	8	—	M6	0.1	4.74×10 ⁻³	0.81	4.44	
40	40	M8×12	30	10	50	8	—	M6	0.1	4.74×10 ⁻³	0.78	4.44	
50	45	M8×12	35	12	62	10	—	M6	0.14	8.08×10 ⁻³	1.3	5.49	
50	60	M8×12	35	12	62	10	—	M6	0.14	8.08×10 ⁻³	2	5.49	
60	45	M10×16	43	17	67	11	—	M6	0.17	1.29×10 ⁻²	1.8	6.91	
60	60	M10×16	43	17	67	11	—	M6	0.17	1.29×10 ⁻²	2.4	6.91	
75	75	M12×20	50	20.5	80	13	—	M6	0.2	3.16×10 ⁻²	4.1	11.08	

Note) The overall length of the nut will increase when equipping the QZ lubricating device. See [A15-344](#) for further details.

CNF No Preload

DN value	70000
----------	-------

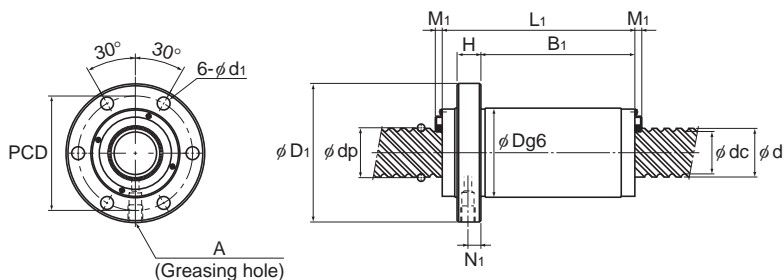

Unit: mm

Model No.	Screw shaft outer diameter		Lead	Ball center-to-center diameter	Thread minor diameter	No. of loaded circuits	Basic load rating		Rigidity	Nut dimensions				
	d	Ph					Ca	C _{0a}		Outer diameter	Flange diameter	Overall length	H	B ₁
	kN	kN	N/ μ m	Rows X turns	D	D ₁	L ₁							
CNF 1530-6	15	30	15.75	12.5	4×1.6	10.1	24.7	310	32	53	63	10	47	
CNF 2040-6	20	40	20.75	17.5	4×1.65	12	34.4	400	37	57	81	10	65	
CNF 2550-6	25	50	26	21.9	4×1.65	18.9	53.9	460	45	69	102	12	81.5	
CNF 3060-6	30	60	31.25	26.4	4×1.65	26.2	77.7	600	55	89	122	15	97	

Model No.	Nut dimensions					Axial clearance	Standard shaft length	Screw shaft inertial moment/mm ²	Nut mass	Shaft mass
	PCD	d ₁	Greasing hole		Seal					
CNF 1530-6	43	5.5	5	M6	3.5	0.1	500, 1000, 1500	3.9×10^{-4}	0.42	1.19
CNF 2040-6	47	5.5	5.5	M6	3.5	0.1	500, 1000, 1500, 2000	1.23×10^{-4}	0.5	2.12
CNF 2550-6	57	6.6	7	M6	3.5	0.1	1000, 1500, 2000, 3000	3.01×10^{-3}	0.85	3.34
CNF 3060-6	71	9	9	M6	3.8	0.14	1000, 2000, 3000, 4000	6.24×10^{-3}	1.7	4.84

Note) The overall length of the nut will increase when equipping the QZ lubricating device. See **A15-344** for further details.

Model number coding

CNF2040-6 ZZ +1500L C7 T H1K

Model No.	Contamination protection accessory symbol (*1)	Overall screw shaft length (in mm)	Accuracy symbol (*2)	Symbol for rolled shaft	Recommended shaft ends shape code
-----------	--	------------------------------------	----------------------	-------------------------	-----------------------------------

(*1) See **A15-336**. (*2) See **A15-12**.

Model Number Coding

Model number coding

Ball Screw Nut

BTK1405V-2.6 ZZ

Model number

Seal symbol

no symbol: without seal

ZZ: brush seal attached to both ends of the ball screw nut (see [A15-336](#))

Screw Shaft

TS 14 05 +500L C7

Accuracy symbol (see [A15-12](#)) (no symbol for class C10)

Overall screw shaft length (in mm)

Lead (in mm)

Screw shaft outer diameter (in mm)

Symbol for rolled ball screw shaft

Combination of the Ball Screw Nut and the Screw Shaft

BTK1405V-2.6 ZZ +500L C7 T

Model number

Symbol for rolled shaft

Accuracy symbol (see [A15-12](#)) (no symbol for class C10)

Overall screw shaft length (in mm)

Seal symbol

no symbol: without seal

ZZ: brush seal attached to both ends of the ball screw nut (see [A15-336](#))

Rolled Ball Screw model JPF

JPF1404-4 RR GO +500L C7 T

Model number

Symbol for rolled shaft

Accuracy symbol (see [A15-12](#)) (no symbol for class C10)

Overall screw shaft length (in mm)

Axial clearance symbol

Seal symbol

no symbol: without seal

RR: Labyrinth seal attached to both ends of the ball screw nut (see [A15-336](#))

Standard Unfinished Shaft Ends Rolled Ball Screw

Model MTF

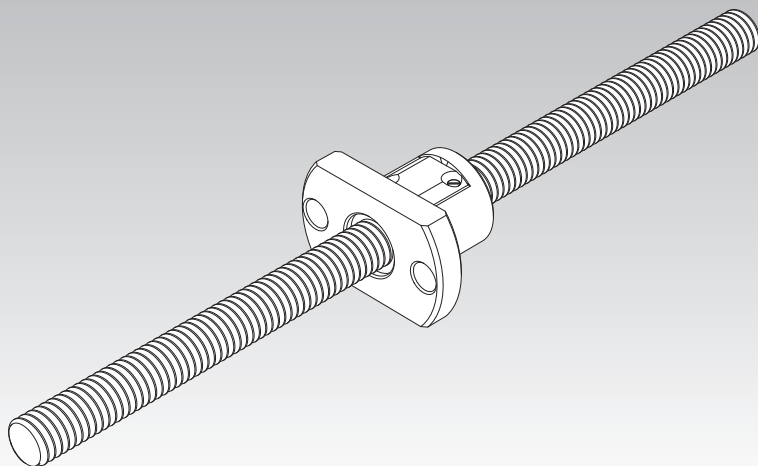

Point of Selection	A15-8
Options	A15-336
Model No.	A15-353
Precautions on Use	A15-358
Accessories for Lubrication	A24-1
Mounting Procedure and Maintenance	B15-104
Accuracy of the Mounting Surface	A15-14
DN Value	A15-33
Support Unit	A15-300
Recommended Shapes of Shaft Ends	A15-308

Structure and Features

The use of a guide plate system provides a compact design with a round outer diameter for the nut. The screw shaft is roll-molded with a high degree of precision to ensure smooth operation.

[Achieves Lead Angle Accuracy of Class C7]

The high-precision roll molding provides normal grade ($\pm 0.1/300$ mm) or C7 grade ($\pm 0.05/300$ mm) error in the amount of movement. The axial clearance is also small at 0.05 mm, allowing the product to be used in a wide range of applications.

[Quick delivery, low cost]

Nut and screw shaft (standard sized) combinations are always stocked together; making them affordable, quick, and easy to deliver.

[Simple shaft end machining]

To facilitate additional machining of screw shaft ends, a section has been left unhardened. Use nut stroke ranges that are within the hardened area shown in the specification tables.

Types and Features

Model MTF

A miniature type with a screw shaft diameter of $\phi 6$ to $\phi 12$ mm and a lead of 1 to 2 mm.

Specification Table \Rightarrow **A15-286**

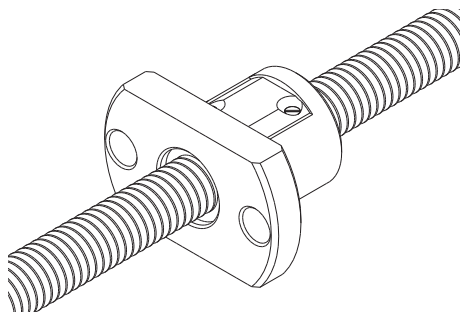

MTF (Unfinished Shaft Ends) No Preload

DN value	50000
----------	-------

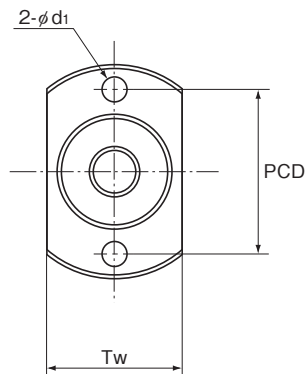

Model No.	Screw shaft outer diameter d	Lead Ph	Ball center-to-center diameter dp	Thread minor diameter dc	No. of loaded circuits Rows×Turns	Basic load rating		Rigidity K N/μm		
						Ca kN	C _{ca} kN		Outer diameter D	Flange diameter D _i
MTF 0601-3.7	6	1	6.15	5.3	1×3.7	0.7	1.2	70	13	30
MTF 0802-3.7	8	2	8.3	6.6	1×3.7	2.1	3.8	90	20	40
MTF 1002-3.7	10	2	10.3	8.6	1×3.7	2.3	4.8	110	23	43
MTF 1202-3.7	12	2	12.3	10.6	1×3.7	2.5	5.8	130	25	47

Model number coding

MTF 08 02 -3.7 +250L C7 T

Model No.

Overall shaft length
(in mm)

Symbol for ball screw shaft

Screw shaft
outer diameter
(in mm)

Lead
(in mm)

Accuracy symbol (No symbol for Normal Grade)

Note) Model MTF is only sold as sets (ball screw nut and screw shaft).
Model MTF is applied only with anti-rust oil.

Standard Unfinished Shaft Ends Rolled Ball Screw

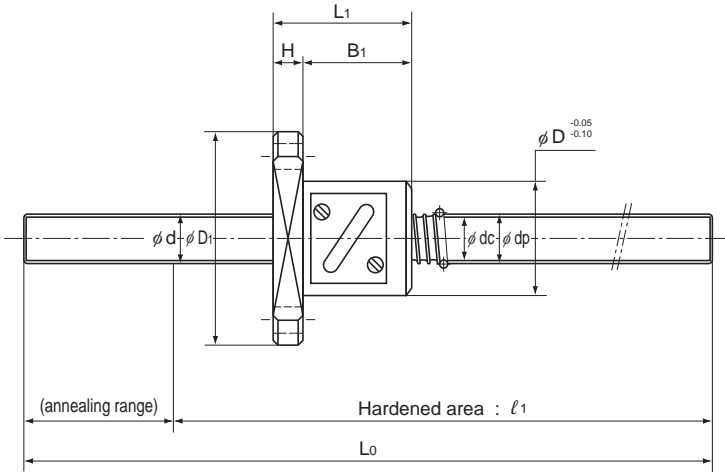

Unit: mm

Nut dimensions							Axial clearance	Standard shaft length	l_1	Screw shaft inertial moment/mm kg-cm ² /mm	Nut mass kg	Shaft mass kg/m
Overall length L_1	H	B_1	PCD	d_i	T_w							
21	5	16	21.5	3.4	17	0.05	150	100	9.99×10^{-6}	0.03	0.19	
							250	200				
28	6	22	30	4.5	24	0.05	150	95	3.16×10^{-5}	0.08	0.31	
							250	195				
28	6	22	33	4.5	27	0.05	200	140	7.71×10^{-5}	0.1	0.52	
							300	240				
30	8	22	36	5.5	29	0.05	200	140	1.6×10^{-4}	0.13	0.77	
							300	240				

Rolled Rotary Ball Screw

Model BLR

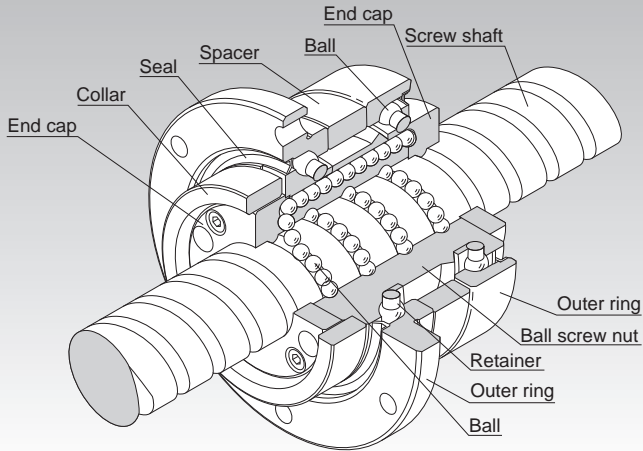

Fig.1 Structure of Large Lead Rotary Nut Ball Screw Model BLR

Point of Selection	A15-8
Options	A15-336
Model No.	A15-353
Precautions on Use	A15-358
Accessories for Lubrication	A24-1
Mounting Procedure and Maintenance	B15-104
Accuracy Standards	A15-290
Example of Assembly	A15-291
Axial Clearance	A15-19
Maximum Length of the Screw Shaft	A15-24
DN Value	A15-33

Structure and Features

The Rotary Ball Screw is a rotary-nut ball screw unit that has an integrated structure consisting of a ball screw nut and a support bearing. The support bearing is an angular bearing that has a contact angle of 60°, contains an increased number of balls and achieves a large axial rigidity.

Model BLR is divided into two types: the Precision Ball Screw and the Rolled Screw Ball.

[Smooth Motion]

It achieves smoother motion than rack-and-pinion based straight motion.

[Low Noise even in High-speed Rotation]

Model BLR produces very low noise when the balls are picked up along the end cap. In addition, the balls circulate by passing through the ball screw nut, allowing this model to be used at high speed.

[High Rigidity]

The support bearing of this model is larger than that of the screw shaft rotational type. Thus, its axial rigidity is significantly increased.

[Compact]

Since the nut and the support bearing are integrated, a highly accurate, and a compact design is achieved.

[Easy Installation]

By simply mounting this model to the housing using bolts, a ball screw nut rotating mechanism can be obtained. (For the housing's inner-diameter tolerance, H7 is recommended.)

Type

[No Preload Type]

Model BLR

Specification Table → **A15-294**

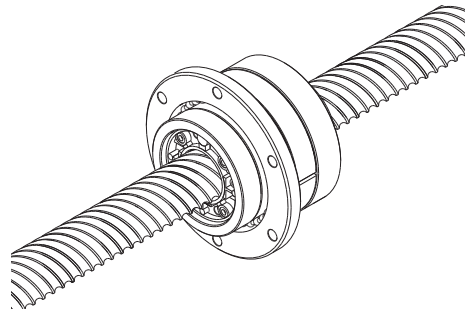

Accuracy Standards

The accuracy of model BLR is compliant with the JIS standard (JIS B 1192-1997) except for the radial runout of the circumference of the ball screw nut from the screw axis (D) and the perpendicularity of the flange-mounting surface against the screw axis (C).

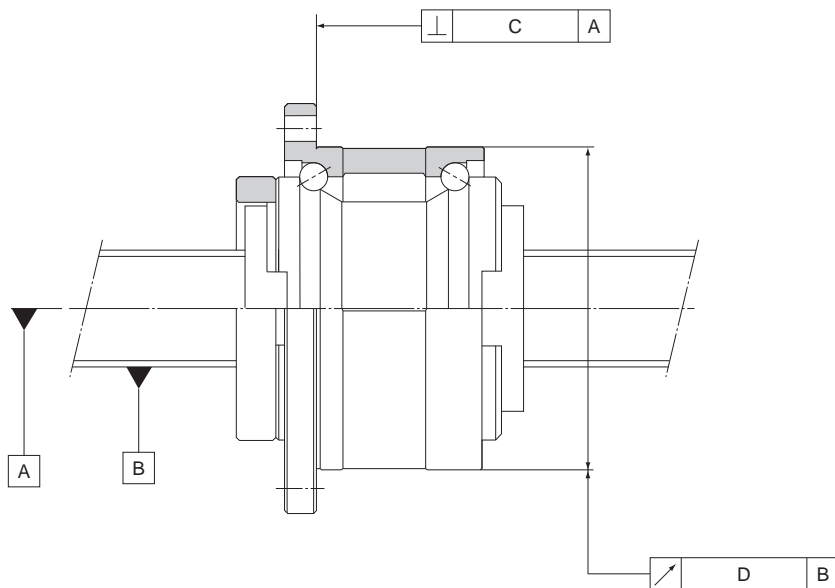

Unit: mm

Lead angle accuracy	C7, C8, C10	
Accuracy grades	C10	
Model No.	C	D
BLR 1616	0.035	0.065
BLR 2020	0.035	0.065
BLR 2525	0.035	0.065
BLR 3232	0.035	0.065
BLR 3636	0.036	0.066
BLR 4040	0.046	0.086
BLR 5050	0.046	0.086

Example of Assembly

[Example of Mounting Ball Screw Nut Model BLR]

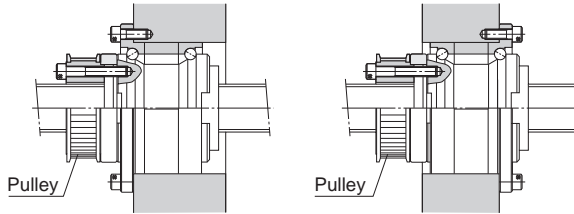

Standard installation method

Inverted flange

Note) If the flange is to be inverted, indicate "K" in the model number. (applicable only to model BLR)

Example: BLR 2020-3.6 **K** UU

Symbol for inverted flange

(No symbol for standard flange orientation)

[Important note concerning model BLR]

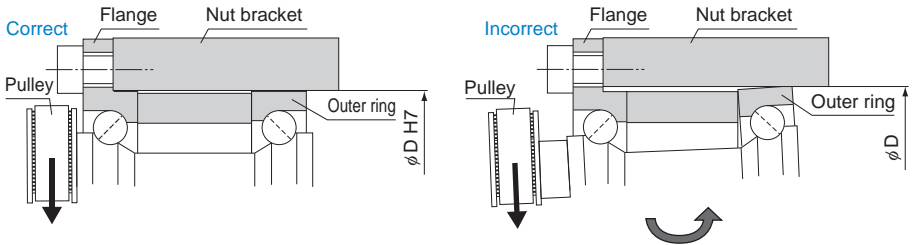

Note) Since the outer rings are separable, it is necessary to include an internal diameter tolerance in the nut bracket so that the outer ring on the side opposite from the flange does not shift. (H7 is recommended.)

[Example of Mounting Model BLR on the Table]

- (1) Example of mounting on a long table
(Free screw shaft, fixed ball screw nut)

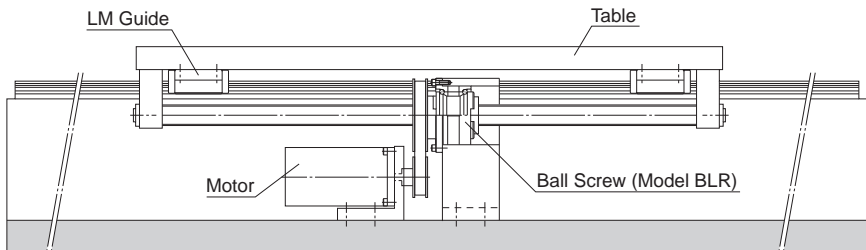

Fig.2 Example of Installation on the Table (Ball Screw Nut Fixed)

- (2) Example of mounting on a short table and long strokes
(Free ball screw nut, fixed screw shaft)

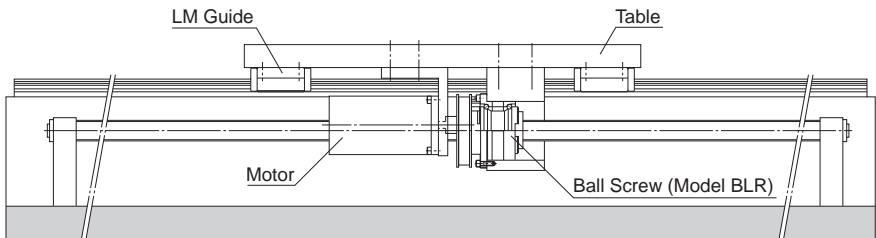
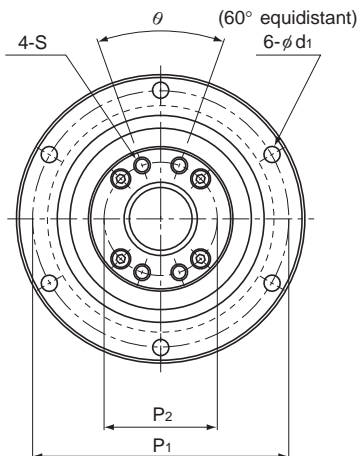

Fig.3 Example of Installation on the Table (Screw Shaft Fixed)

Note) A design incorporating tension mechanism is needed when using a timing belt.
For belt tensions, see the belt manufacturer's catalog.
When used with a long stroke, apply tension to the screw shaft to reduce oscillations.

BLR (Rolled Ball Screw) No Preload

DN value	70000
----------	-------



Model No.	Screw shaft outer diameter d	Thread minor diameter dc	Lead Ph	Ball center-to-center diameter dp	Basic load rating		Outer diameter D	Flange diameter D ₁	Overall length L ₁	D ₃
					Ca kN	C _{0a} kN				
BLR 1616-3.6	16	13.7	16	16.65	5.8	12.9	52 ⁰ _{-0.007}	68	43.5	40 ⁰ _{-0.025}
BLR 2020-3.6	20	17.5	20	20.75	7.7	22.3	62 ⁰ _{-0.007}	78	54	50 ⁰ _{-0.025}
BLR 2525-3.6	25	21.9	25	26	12.1	35	72 ⁰ _{-0.007}	92	65	58 ⁰ _{-0.03}
BLR 3232-3.6	32	28.3	32	33.25	17.3	53.9	80 ⁰ _{-0.007}	105	80	66 ⁰ _{-0.03}
BLR 3636-3.6	36	31.7	36	37.4	22.4	70.5	100 ⁰ _{-0.008}	130	93	80 ⁰ _{-0.03}
BLR 4040-3.6	40	35.2	40	41.75	28.1	89.8	110 ⁰ _{-0.008}	140	98	90 ⁰ _{-0.035}
BLR 5050-3.6	50	44.1	50	52.2	42.1	140.4	120 ⁰ _{-0.008}	156	126	100 ⁰ _{-0.035}

Model number coding

BLR2020-3.6 K UU +1000L C7 T

Model number	Flange orientation symbol (*1)	Overall screw shaft length (in mm)	Symbol for rolled Ball Screw
	Symbol for support bearing seal (*2)	Accuracy symbol (*3)	

(*1) See **A15-291**. (*2) UU: seal attached on both ends; No symbol: without seal. (*3) See **A15-12**.

Note) For clearance in the axial direction, see **A15-19**.

Rolled Rotary Ball Screw

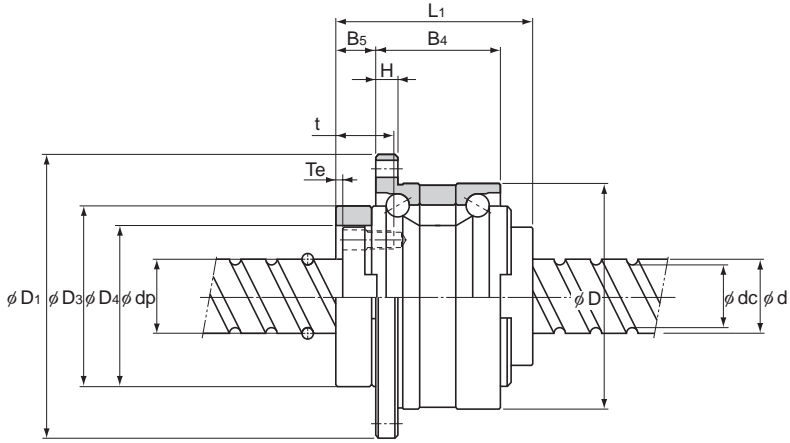

Unit: mm

Ball screw dimensions												Support bearing basic load rating		Nut inertial moment kg-cm ²	Nut mass kg	Shaft mass kg/m
D ₄	H	B ₄	B ₅	T _e	P ₁	P ₂	S	t	d ₁	θ°	Ca kN	C _{0a} kN				
32	$^{+0.025}_0$	5	27.5	9	2	60	25	M4	12	4.5	40	19.4	19.2	0.48	0.38	1.35
39	$^{+0.025}_0$	6	34	11	2	70	31	M5	16	4.5	40	26.8	29.3	1.44	0.68	2.17
47	$^{+0.025}_0$	8	43	12.5	3	81	38	M6	19	5.5	40	28.2	33.3	3.23	1.1	3.41
58	$^{+0.03}_0$	9	55	14	3	91	48	M6	19	6.6	40	30	39	6.74	1.74	5.69
66	$^{+0.03}_0$	11	62	17	3	113	54	M8	22	9	40	56.4	65.2	16.8	3.2	7.12
73	$^{+0.03}_0$	11	68	16.5	3	123	61	M8	22	9	50	59.3	74.1	27.9	3.95	8.76
90	$^{+0.035}_0$	12	80	25	4	136	75	M10	28	11	50	62.2	83	58.2	6.22	13.79

Ball Screw

Maximum Length of the Ball Screw Shaft

Table1 shows the manufacturing limit lengths of precision Ball Screws by accuracy grades, Table2 shows the manufacturing limit lengths of precision Ball Screws compliant with DIN standard by accuracy grades, and Table3 shows the manufacturing limit lengths of rolled Ball Screws by accuracy grades.

If the shaft dimensions exceed the manufacturing limit in Table1, Table2 or Table3, contact THK.

Table1 Maximum Length of the Precision Ball Screw by Accuracy Grade

Unit: mm

Screw shaft outer diameter	Overall screw shaft length						
	C0	C1	C2	C3	C5	C7	
4	90	110	120	120	120	120	
6	150	170	210	210	210	210	
8	230	270	340	340	340	340	
10	350	400	500	500	500	500	
12	440	500	630	680	680	680	
13	440	500	630	680	680	680	
14	530	620	770	870	890	890	
15	570	670	830	950	980	1100	
16	620	730	900	1050	1100	1400	
18	720	840	1050	1220	1350	1600	
20	820	950	1200	1400	1600	1800	
25	1100	1400	1600	1800	2000	2400	
28	1300	1600	1900	2100	2350	2700	
30	1450	1700	2050	2300	2570	2950	
32	1600	1800	2200	2500	2800	3200	
36	2000	2100	2550	2950	3250	3650	
40		2400	2900	3400	3700	4300	
45		2750	3350	3950	4350	5050	
50		3100	3800	4500	5000	5800	
55		3450	4150	5300	6050	6500	
63		4000	5200	5800	6700	7700	
70				6300	6450	7650	9000
80					7900	9000	10000
100					10000	10000	

Table2 Manufacturing limit lengths of precision Ball Screws (DIN standard compliant Ball Screws)

Unit: mm

Shaft diameter	Ground shaft			CES shaft			
	C3	C5	C7	Cp3	Cp5	Ct5	Ct7
16	1050	1100	1400	1050	1100	1100	1400
20	1400	1600	1800	1400	1600	1600	1800
25	1800	2000	2400	1800	2000	2000	2400
32	2500	2800	3200	2500	2800	2800	3200
40	3400	3700	4300	3400	3700	3700	4300
50	4500	5000	5800	—	—	—	—
63	5800	6700	7700	—	—	—	—

Table3 Maximum Length of the Rolled Ball Screw by Accuracy Grade

Unit: mm

Screw shaft outer diameter	Overall screw shaft length		
	C7	C8	C10
6 to 8	320	320	—
10 to 12	500	1000	—
14 to 15	1500	1500	1500
16 to 18	1500	1800	1800
20	2000	2200	2200
25	2000	3000	3000
28	3000	3000	3000
30	3000	3000	4000
32 to 36	3000	4000	4000
40	3000	5000	5000
45	3000	5500	5500
50	3000	6000	6000

Ball Screw

Ball Screw Peripherals

Support Unit

Models EK, BK, FK, EF, BF and FF

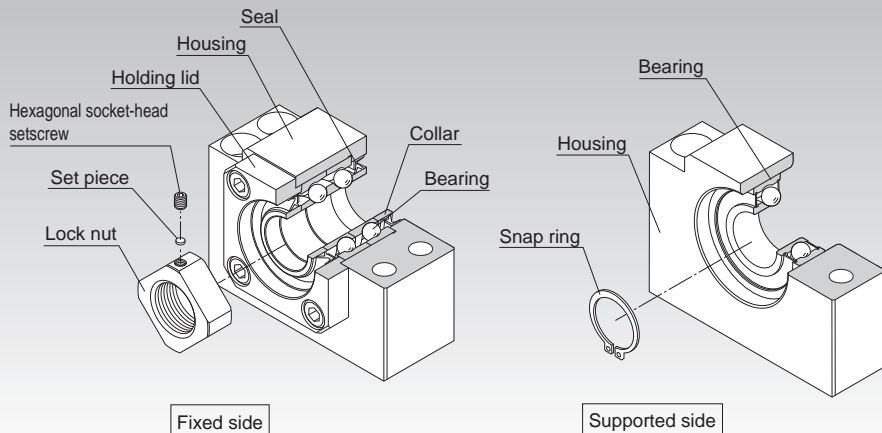

Fig.1 Structure of the Support Unit

Structure and Features

The support unit comes in six types: models EK, FK, EF, and FF, which are tailored to model BNK precision ball screw with finished shaft ends, and models BK and BF, which are standardized for general ball screws.

The support unit on the fixed side includes a JIS Class 5-compliant angular bearing provided with an adjusted preload.

The Support Unit on the supported side uses a deep-groove ball bearing.

The internal bearings of the Support Unit models EK, FK and BK contain an appropriate amount of lithium soap-group grease that is sealed with a special seal. Thus, these models are capable of operating over a long period.

[Uses the Optimal Bearing]

To ensure the rigidity balance with the Ball Screw, the Support Unit uses an angular bearing (contact angle: 30°; DF configuration) with a high rigidity and a low torque. Miniature Support Unit models EK/FK 4, 5 and 6 are incorporated with a miniature angular bearing with a contact angle of 45° developed exclusively for miniature Ball Screws. This bearing has a greater contact angle of 45° and an increased number of balls with a smaller diameter. The high rigidity and accuracy of the miniature angular bearing provides the stable rotational performance.

[Support Unit Shapes]

The square and round shapes are available for the Support Unit to allow the selection according to the intended use.

Example of Installation

Square Type

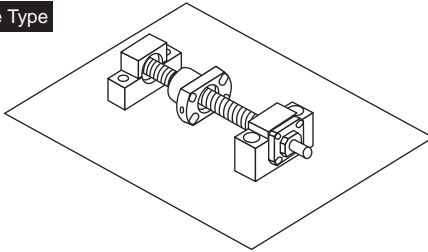

Round Type

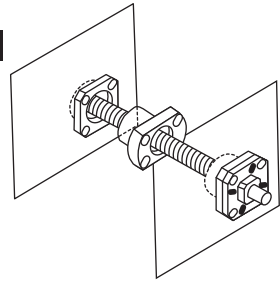

[Compact and Easy Installation]

The Support Unit is compactly designed to accommodate the space in the installation site. As the bearing is provided with an appropriately adjusted preload, the Support Unit can be assembled with a Ball Screw unit with no further machining. Accordingly, the required man-hours in the assembly can be reduced and the assembly accuracy can be increased.

Type

[For the Fixed Side]

Square Type Model EK

Specification Table⇒ **A15-310**

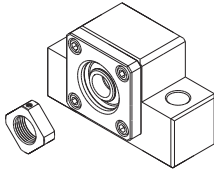

(Inner diameter: $\phi 4$ to $\phi 20$)

Square Type Model BK

Specification Table⇒ **A15-312**

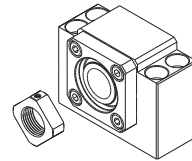

(Inner diameter: $\phi 10$ to $\phi 40$)

Round Type Model FK

Specification Table⇒ **A15-314**

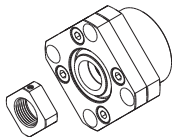

(Inner diameter: $\phi 4$ to $\phi 30$)

[For the Supported Side]

Square Type Model EF

Specification Table⇒ **A15-318**

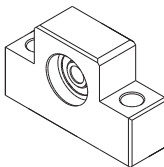

(Inner diameter: $\phi 6$ to $\phi 20$)

Square Type Model BF

Specification Table⇒ **A15-320**

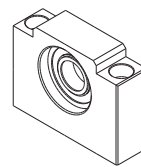

(Inner diameter: $\phi 8$ to $\phi 40$)

Round Type Model FF

Specification Table⇒ **A15-322**

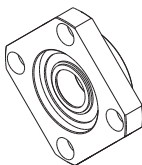

(Inner diameter: $\phi 6$ to $\phi 30$)

Types of Support Units and Applicable Screw Shaft Outer Diameters

Inner diameter of fixed-side Support Unit (mm)	Inner diameter of supported-side Support Unit (mm)	Applicable Model No. of fixed-side Support Unit	Applicable model No. of the supported side Support Unit	Type BNK with Unfinished Shaft Ends(Applicable Model No.)	Recommended Shapes of Shaft Ends(Applicable Shaft Outer Diameter ϕ D)	
					Shaft End H (mm)	Shaft End J (mm)
4	—	EK 4 FK 4	—	BNK0401 BNK0501	ϕ 6	—
5	—	EK 5 FK 5	—	BNK0601	ϕ 8	—
6	6	EK 6 FK 6	EF 6 FF 6	BNK0801 BNK0802 BNK0810	ϕ 8 ϕ 10	—
8	6	EK 8 FK 8	EF 8 FF 6	BNK1002	ϕ 12	—
10	8	EK 10 FK 10 BK 10	EF 10 FF 10 BF 10	BNK1004 BNK1010 BNK1202 BNK1205 BNK1208	ϕ 14 ϕ 15	ϕ 14 ϕ 15
12	10	EK 12 FK 12 BK 12	EF 12 FF 12 BF 12	BNK1402 BNK1404 BNK1408 BNK1510 BNK1520 BNK1616	ϕ 16 ϕ 18	ϕ 16 ϕ 18
15	15	EK 15 FK 15	EF 15 FF 15	BNK2010 BNK2020	ϕ 20 ϕ 25	—
		BK 15	BF 15	—	—	ϕ 20
17	17	BK 17	BF 17	—	—	ϕ 25
20	20	EK 20 FK 20	EF 20 FF 20	BNK2520	ϕ 28 ϕ 30 ϕ 32	—
		BK 20	BF 20	—	—	ϕ 28 ϕ 30 ϕ 32
25	25	FK 25	FF 25	—	ϕ 36	—
		BK 25	BF 25	—	—	ϕ 36
30	30	FK 30	FF 30	—	ϕ 40	ϕ 40
		BK 30	BF 30	—		
35	35	BK 35	BF 35	—	—	ϕ 45
40	40	BK 40	BF 40	—	—	ϕ 50 ϕ 55

Note1) The Supports Units in this table apply only to those Ball Screw models with recommended shaft ends shapes H, J and K, indicated on **A15-308**.

Note2) For Recommended Shapes of Shaft Ends H, J, and K; refer to pages **A15-324** to **A15-329**.

Model Numbers of Bearings and Characteristic Values

Angular ball bearing on the fixed side					Deep-groove ball bearing on the supported side			
Support Unit model No.	Bearing	Axial direction			Support Unit model No.	Bearing model No.	Radial direction	
		Basic dynamic load rating Ca (kN)	Note) Permissible load (kN)	Rigidity (N/μm)			Basic dynamic load rating C(kN)	Basic static load rating Co(kN)
EK 4 FK 4	AC4-12 (DF P5)	0.93	1.1	27	—	—	—	—
EK 5 FK 5	AC5-14 (DF P5)	1	1.24	29	—	—	—	—
EK 6 FK 6	AC6-16 (DF P5)	1.38	1.76	35	EF 6 FF 6	606ZZ	2.19	0.87
EK 8 FK 8	79M8A (DF P5)	2.93	2.15	49	EF 8	606ZZ	2.19	0.87
EK 10 FK 10 BK 10	7000 equivalent (DF P5)	6.08	3.1	65	EF 10 FF 10 BF 10	608ZZ	3.35	1.4
EK 12 FK 12 BK 12	7001 equivalent (DF P5)	6.66	3.25	88	EF 12 FF 12 BF 12	6000ZZ	4.55	1.96
EK 15 FK 15 BK 15	7002 equivalent (DF P5)	7.6	4	100	EF 15 FF 15 BF 15	6002ZZ	5.6	2.84
BK 17	7203 equivalent (DF P5)	13.7	5.85	125	BF 17	6203ZZ	9.6	4.6
EK 20 FK 20	7204 equivalent (DF P5)	17.9	9.5	170	EF 20 FF 20	6204ZZ	12.8	6.65
BK 20	7004 equivalent (DF P5)	12.7	7.55	140	BF 20	6004ZZ	9.4	5.05
FK 25 BK 25	7205 equivalent (DF P5)	20.2	11.5	190	FF 25 BF 25	6205ZZ	14	7.85
FK 30 BK 30	7206 equivalent (DF P5)	28	16.3	195	FF 30 BF 30	6206ZZ	19.5	11.3
BK 35	7207 equivalent (DF P5)	37.2	21.9	255	BF 35	6207ZZ	25.7	15.3
BK 40	7208 equivalent (DF P5)	44.1	27.1	270	BF 40	6208ZZ	29.1	17.8

Note) "Permissible load" indicates the static permissible load.

Example of Installation

[Square Type Support Unit]

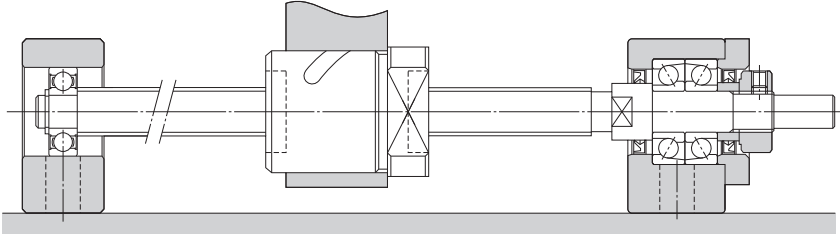

Fig.2 Example of Installing a Square Type Support Unit

[Round Type Support Unit]

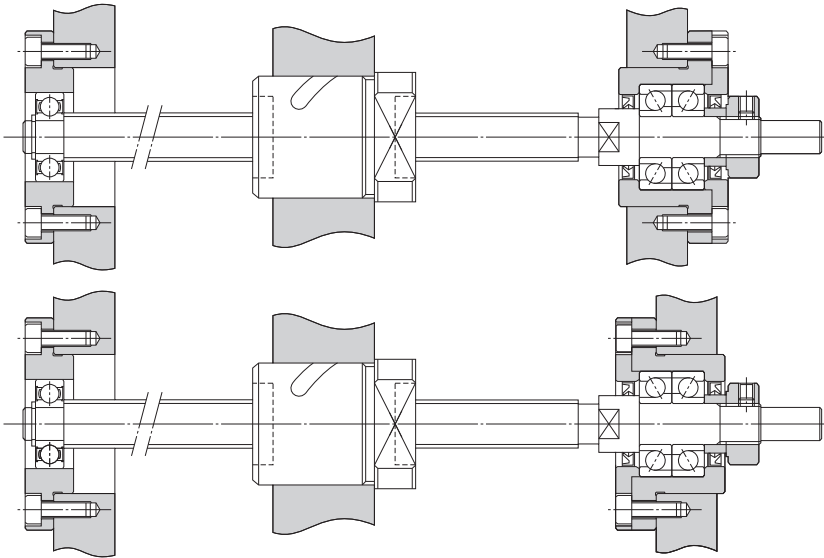

Fig.3 Example of Installing a Round Type Support Unit

Mounting Procedure

[Installing the Support Unit]

- (1) Install the fixed side Support Unit with the screw shaft.
- (2) After inserting the fixed side Support Unit, secure the lock nut using the fastening set piece and the hexagonal socket-head setscrews.
- (3) Attach the supported side bearing to the screw shaft and secure the bearing using the snap ring, and then install the assembly to the housing on the supported side.

Note1) Do not disassemble the Support Unit.

Note2) When inserting the screw shaft to the Support Unit, take care not to let the oil seal lip turn outward.

Note3) When securing the set piece with a hexagonal socket-head setscrew, apply an adhesive to the hexagonal socket-head setscrew before tightening it in order to prevent the screw from loosening. If planning to use the product in a harsh environment, it is also necessary to take a measure to prevent other components/parts from loosening. Contact THK for details.

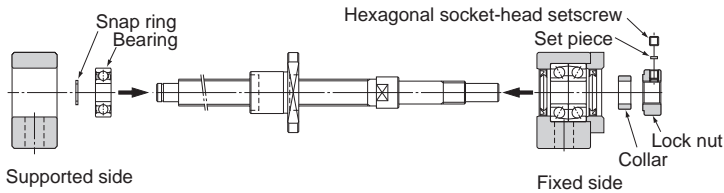

[Installation onto the Table and the Base]

- (1) If using a bracket when mounting the ball screw nut to the table, insert the nut into the bracket and temporarily fasten it.
- (2) Temporarily fasten the fixed side Support Unit to the base. In doing so, press the table toward the fixed side Support Unit to align the axial center, and adjust the table so that it can travel freely.
 - If using the fixed side Support Unit as the reference point, secure a clearance between the ball screw nut and the table or inside the bracket when making adjustment.
 - If using the table as the reference point, make the adjustment either by using the shim (for a square type Support Unit), or securing the clearance between the outer surface of the nut and the inner surface of the mounting section (for a round type Support Unit).
- (3) Press the table toward the fixed-side Support Unit to align the axial center. Make the adjustment by reciprocating the table several times so that the nut travels smoothly throughout the whole stroke, and temporarily secure the Support Unit to the base.

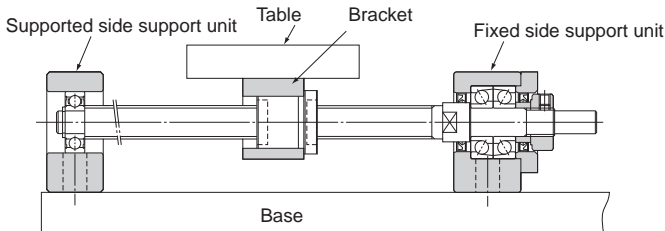

[Checking the Accuracy and Fully Fastening the Support Unit]

While checking the runout of the ball screw shaft end and the axial clearance using a dial gauge, fully fasten the ball screw nut, the nut bracket, the fixed side Support Unit and the supported-side Support Unit, in this order.

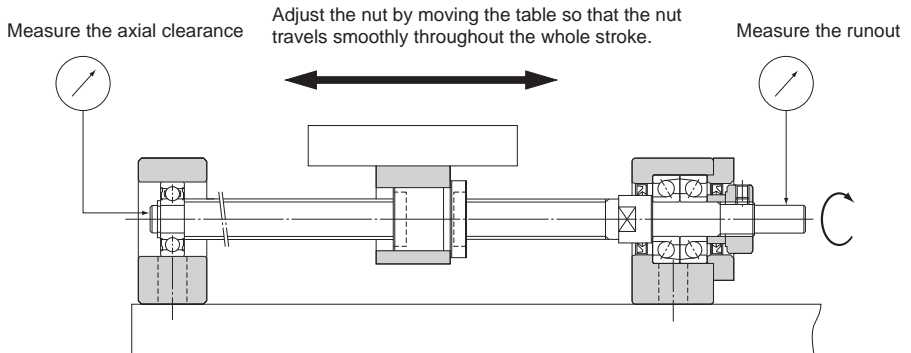

[Connection with the Motor]

- (1) Mount the motor bracket to the base.
- (2) Connect the motor and the ball screw using a coupling.

Note) Make sure the mounting accuracy is maintained.

- (3) Thoroughly perform the break-in for the system.

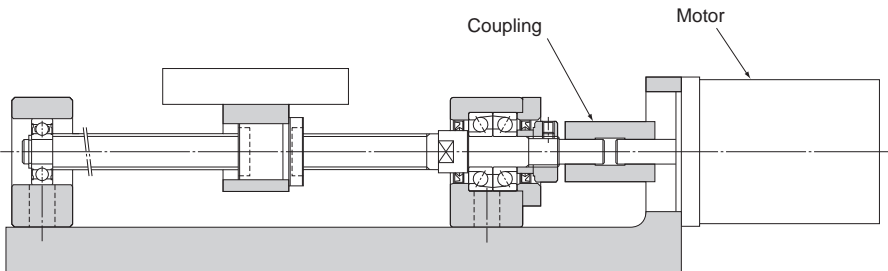

Types of Recommended Shapes of the Shaft Ends

To ensure speedy estimates and manufacturing of Ball Screws, THK has standardized the shaft end shapes of the screw shafts. The recommended shapes of shaft ends consist of shapes H, K and J, which allow standard Support Units to be used.

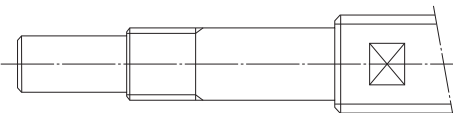
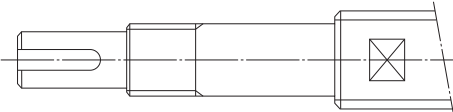
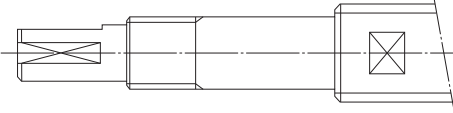
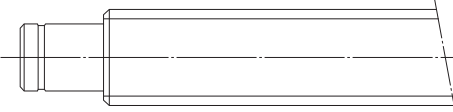
Mounting method	Symbol for shaft end shape		Shape	Supported Support Unit
Fixed	H J	H1		FK EK
		J1		BK
		H2		FK EK
		J2		BK
		H3		FK EK
		J3		BK
Supported	K			FF EF BF

EK Square Type Support Unit on the Fixed Side

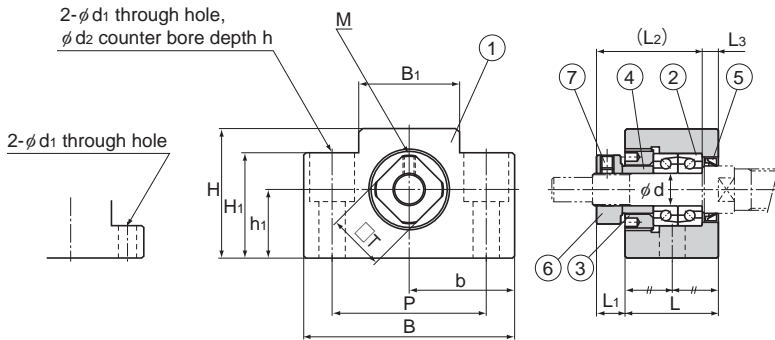

Models EK 4 and 5

Models EK 6 and 8

Model No.	Shaft diameter d	L	L ₁	L ₂	L ₃	B	H	b ±0.02
EK 4	4	15	5.5	17.5	3	34	19	17
EK 5	5	16.5	5.5	18.5	3.5	36	21	18
EK 6	6	20	5.5	22	3.5	42	25	21
EK 8	8	23	7	26	4	52	32	26
EK 10	10	24	6	29.5	6	70	43	35
EK 12	12	24	6	29.5	6	70	43	35
EK 15	15	25	6	36	5	80	49	40
EK 20	20	42	10	50	10	95	58	47.5

Models EK 4 to 8

Part No.	Part name	No. of units
1	Housing	1
2	Bearing	1 set
3	Set nut	1
4	Collar	2
5	Seal	1
6	Lock Nut	1
7	Hexagonal socket-head setscrew (with a set piece)	1

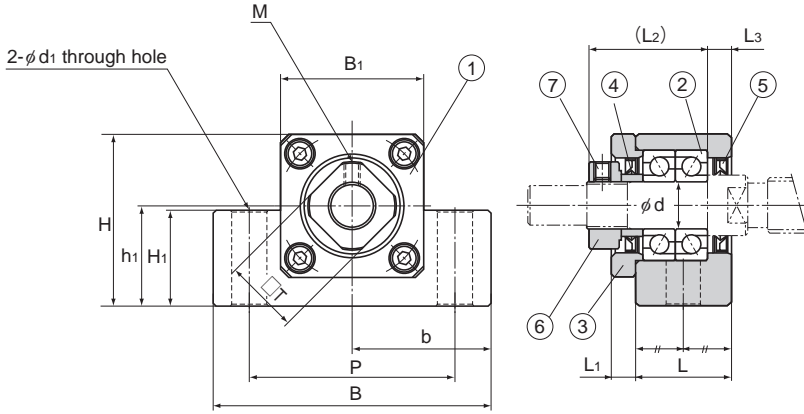

Models EK 10 to 20

Unit: mm

h_1 ± 0.02	B_1	H_1	P	d_1	d_2	h	M	T	Bearing used	Mass kg
10	18	7	26	4.5	—	—	M2.6	10	AC4-12(DF P5)	0.06
11	20	8	28	4.5	—	—	M2.6	11	AC5-14(DF P5)	0.08
13	18	20	30	5.5	9.5	11	M3	12	AC6-16(DF P5)	0.14
17	25	26	38	6.6	11	12	M3	14	79M8A(DF P5)	0.24
25	36	24	52	9	—	—	M3	16	7000 equivalent (DF P5)	0.46
25	36	24	52	9	—	—	M3	19	7001 equivalent (DF P5)	0.44
30	41	25	60	11	—	—	M3	22	7002 equivalent (DF P5)	0.55
30	56	25	75	11	—	—	M4	30	7204 equivalent (DF P5)	1.35

Models EK 10 to 20

Part No.	Part name	No. of units
1	Housing	1
2	Bearing	1 set
3	Holding lid	1
4	Collar	2
5	Seal	2
6	Lock Nut	1
7	Hexagonal socket-head setscrew (with a set piece)	1

BK Square Type Support Unit on the Fixed Side

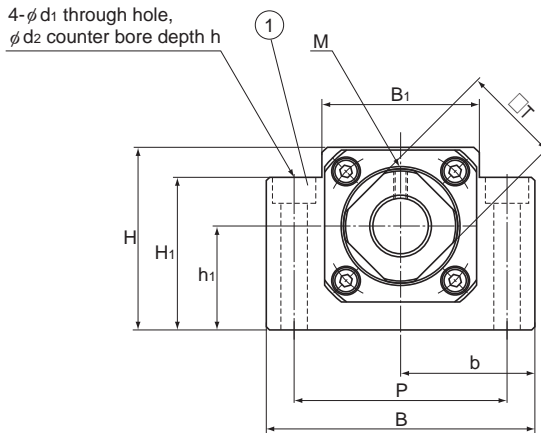

Model No.	Shaft diameter	L	L ₁	L ₂	L ₃	B	H	b ±0.02	h ₁ ±0.02	B ₁	H ₁
	d										
BK 10	10	25	5	29	5	60	39	30	22	34	32.5
BK 12	12	25	5	29	5	60	43	30	25	35	32.5
BK 15	15	27	6	32	6	70	48	35	28	40	38
BK 17	17	35	9	44	7	86	64	43	39	50	55
BK 20	20	35	8	43	8	88	60	44	34	52	50
BK 25	25	42	12	54	9	106	80	53	48	64	70
BK 30	30	45	14	61	9	128	89	64	51	76	78
BK 35	35	50	14	67	12	140	96	70	52	88	79
BK 40	40	61	18	76	15	160	110	80	60	100	90

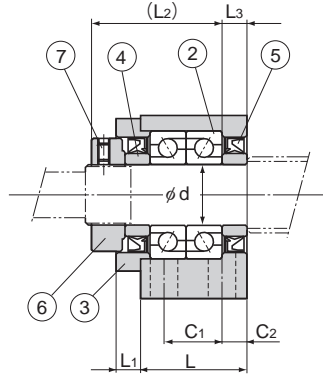

Unit: mm

	P	C ₁	C ₂	d ₁	d ₂	h	M	T	Bearing used	Mass kg
	46	13	6	6.6	10.8	5	M3	16	7000 equivalent (DF P5)	0.39
	46	13	6	6.6	10.8	1.5	M3	19	7001 equivalent (DF P5)	0.41
	54	15	6	6.6	11	6.5	M3	22	7002 equivalent (DF P5)	0.57
	68	19	8	9	14	8.5	M4	24	7203 equivalent (DF P5)	1.27
	70	19	8	9	14	8.5	M4	30	7004 equivalent (DF P5)	1.19
	85	22	10	11	17.5	11	M5	35	7205 equivalent (DF P5)	2.3
	102	23	11	14	20	13	M6	40	7206 equivalent (DF P5)	3.32
	114	26	12	14	20	13	M8	50	7207 equivalent (DF P5)	4.33
	130	33	14	18	26	17.5	M8	50	7208 equivalent (DF P5)	6.5

Part No.	Part name	No. of units
1	Housing	1
2	Bearing	1 set
3	Holding lid	1
4	Collar	2
5	Seal	2
6	Lock Nut	1
7	Hexagonal socket-head setscrew (with a set piece)	1

FK Round Type Support Unit on the Fixed Side

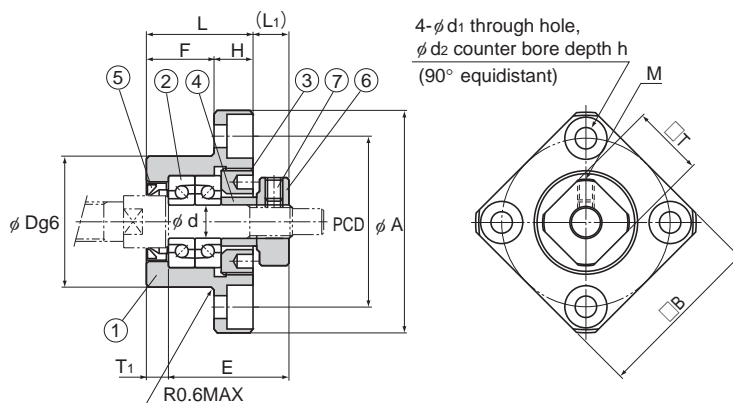

Mounting method A

Models FK 4 to 8

Model No.	Shaft diameter	L	H	F	E	D	A	PCD	B
	d								
FK 4	4	15	6	9	17.5	18 -0.006 -0.017	32	24	25
FK 5	5	16.5	6	10.5	18.5	20 -0.007 -0.02	34	26	26
FK 6	6	20	7	13	22	22 -0.007 -0.02	36	28	28
FK 8	8	23	9	14	26	28 -0.007 -0.02	43	35	35

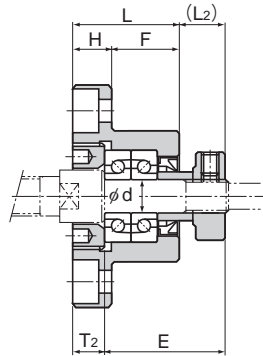

Mounting method B

Unit: mm

	Installation procedure A		Installation procedure B		d_1	d_2	h	M	T	Bearing used	Mass kg
	L_1	T_1	L_2	T_2							
	5.5	3	6.5	4	3.4	6.5	4	M2.6	10	AC4-12(DF P5)	0.05
	5.5	3.5	7	5	3.4	6.5	4	M2.6	11	AC5-14(DF P5)	0.06
	5.5	3.5	8.5	6.5	3.4	6.5	4	M3	12	AC6-16(DF P5)	0.08
	7	4	10	7	3.4	6.5	4	M3	14	79M8A(DF P5)	0.15

Part No.	Part name	No. of units
1	Housing	1
2	Bearing	1 set
3	Set nut	1
4	Collar	2
5	Seal	1
6	Lock Nut	1
7	Hexagonal socket-head setscrew (with a set piece)	1

FK Round Type Support Unit on the Fixed Side

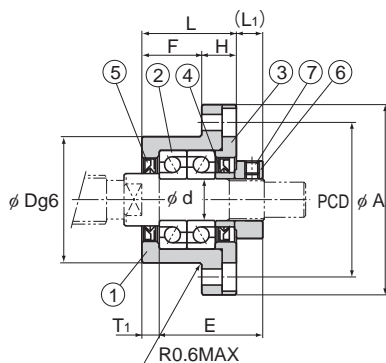

Mounting method A

4- ϕ d1 through hole,
 ϕ d2 counter bore depth h
 (90° equidistant)

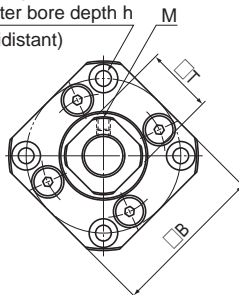

Models FK 10 to 30

Model No.	Shaft diameter	L	H	F	E	D	A	PCD	B
	d								
FK 10	10	27	10	17	29.5	34 -0.009 -0.025	52	42	42
FK 12	12	27	10	17	29.5	36 -0.009 -0.025	54	44	44
FK 15	15	32	15	17	36	40 -0.009 -0.025	63	50	52
FK 20	20	52	22	30	50	57 -0.01 -0.029	85	70	68
FK 25	25	57	27	30	60	63 -0.01 -0.029	98	80	79
FK 30	30	62	30	32	61	75 -0.01 -0.029	117	95	93

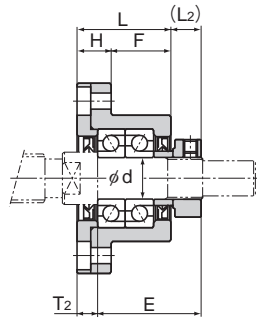

Mounting method B

Unit: mm

	Installation procedure A		Installation procedure B		d_1	d_2	h	M	T	Bearing used	Mass kg
	L_1	T_1	L_2	T_2							
	7.5	5	8.5	6	4.5	8	4	M3	16	7000 equivalent (DF P5)	0.21
	7.5	5	8.5	6	4.5	8	4	M3	19	7001 equivalent (DF P5)	0.22
	10	6	12	8	5.5	9.5	6	M3	22	7002 equivalent (DF P5)	0.39
	8	10	12	14	6.6	11	10	M4	30	7204 equivalent (DF P5)	1.09
	13	10	20	17	9	15	13	M5	35	7205 equivalent (DF P5)	1.49
	11	12	17	18	11	17.5	15	M6	40	7206 equivalent (DF P5)	2.32

Part No.	Part name	No. of units
1	Housing	1
2	Bearing	1 set
3	Holding lid	1
4	Collar	2
5	Seal	2
6	Lock Nut	1
7	Hexagonal socket-head setscrew (with a set piece)	1

EF Square Type Support Unit on the Supported Side

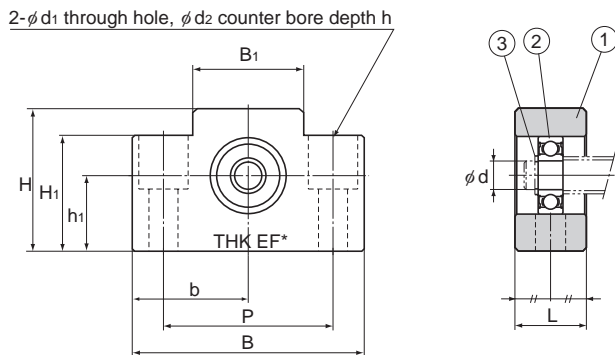

Models EF 6 and 8

Model No.	Shaft diameter d	L	B	H	b ± 0.02	h ₁ ± 0.02	B ₁
EF 6	6	12	42	25	21	13	18
EF 8	6	14	52	32	26	17	25
EF 10	8	20	70	43	35	25	36
EF 12	10	20	70	43	35	25	36
EF 15	15	20	80	49	40	30	41
EF 20	20	26	95	58	47.5	30	56

Note) The area marked with "*" is imprinted with a numeric character(s) as part of the model number.

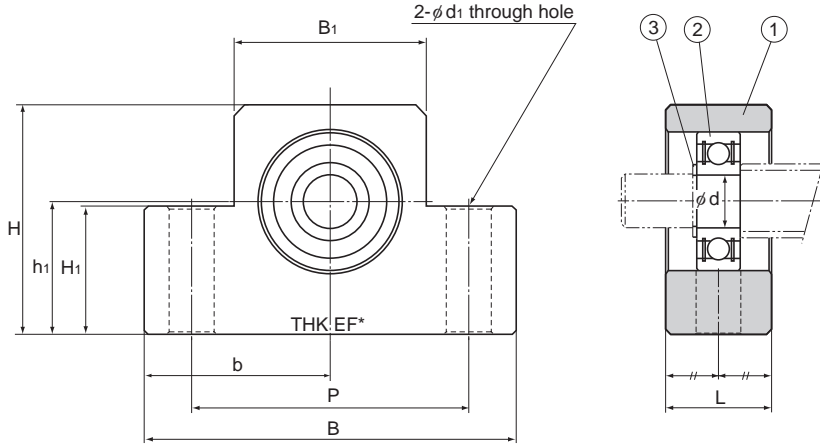

Models EF 10 to 20

Unit: mm

	H_1	P	d_1	d_2	h	Bearing used	Snap ring size	Mass kg
	20	30	5.5	9.5	11	606ZZ	C6	0.07
	26	38	6.6	11	12	606ZZ	C6	0.13
	24	52	9	—	—	608ZZ	C8	0.33
	24	52	9	—	—	6000ZZ	C10	0.32
	25	60	9	—	—	6002ZZ	C15	0.38
	25	75	11	—	—	6204ZZ	C20	0.63

Part No.	Part name	No. of units
1	Housing	1
2	Bearing	1
3	Snap ring	1

BF Square Type Support Unit on the Supported Side

2- ϕ d₁ through hole,
 ϕ d₂ counter bore depth h

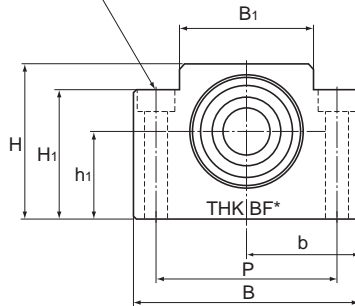

Model No.	Shaft diameter d	L	B	H	b ± 0.02	h ₁ ± 0.02	B ₁	H ₁
BF 10	8	20	60	39	30	22	34	32.5
BF 12	10	20	60	43	30	25	35	32.5
BF 15	15	20	70	48	35	28	40	38
BF 17	17	23	86	64	43	39	50	55
BF 20	20	26	88	60	44	34	52	50
BF 25	25	30	106	80	53	48	64	70
BF 30	30	32	128	89	64	51	76	78
BF 35	35	32	140	96	70	52	88	79
BF 40	40	37	160	110	80	60	100	90

Note) The area marked with "*" is imprinted with a numeric character(s) as part of the model number.

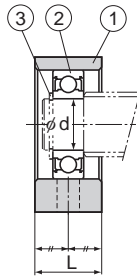

Unit: mm

	P	d_1	d_2	h	Bearing used	Snap ring used	Mass kg
	46	6.6	10.8	5	608ZZ	C8	0.29
	46	6.6	10.8	1.5	6000ZZ	C10	0.3
	54	6.6	11	6.5	6002ZZ	C15	0.38
	68	9	14	8.5	6203ZZ	C17	0.74
	70	9	14	8.5	6004ZZ	C20	0.76
	85	11	17.5	11	6205ZZ	C25	1.42
	102	14	20	13	6206ZZ	C30	1.97
	114	14	20	13	6207ZZ	C35	2.22
	130	18	26	17.5	6208ZZ	C40	3.27

Part No.	Part name	No. of units
1	Housing	1
2	Bearing	1
3	Snap ring	1

FF Round Type Support Unit on the Supported Side

4- ϕ d1 through hole,
 ϕ d2 counter bore depth h
 (90° equidistant)

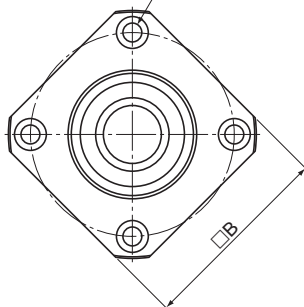

Model No.	Shaft diameter d	L	H	F	D	A
FF 6	6	10	6	4	22 -0.007 -0.02	36
FF 10	8	12	7	5	28 -0.007 -0.02	43
FF 12	10	15	7	8	34 -0.009 -0.025	52
FF 15	15	17	9	8	40 -0.009 -0.025	63
FF 20	20	20	11	9	57 -0.01 -0.029	85
FF 25	25	24	14	10	63 -0.01 -0.029	98
FF 30	30	27	18	9	75 -0.01 -0.029	117

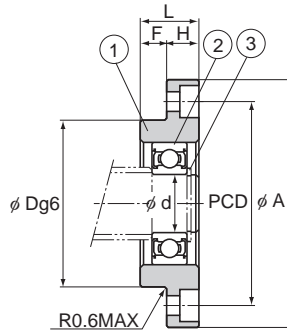

Unit: mm

	PCD	B	d_1	d_2	h	Bearing used	Snap ring used	Mass kg
	28	28	3.4	6.5	4	606ZZ	C6	0.04
	35	35	3.4	6.5	4	608ZZ	C8	0.07
	42	42	4.5	8	4	6000ZZ	C10	0.11
	50	52	5.5	9.5	5.5	6002ZZ	C15	0.2
	70	68	6.6	11	6.5	6204ZZ	C20	0.27
	80	79	9	14	8.5	6205ZZ	C25	0.67
	95	93	11	17.5	11	6206ZZ	C30	1.07

Part No.	Part name	No. of units
1	Housing	1
2	Bearing	1
3	Snap ring	1

Recommended Shapes of Shaft Ends - Shape H (H1, H2 and H3) (For Support Unit Models FK and EK)

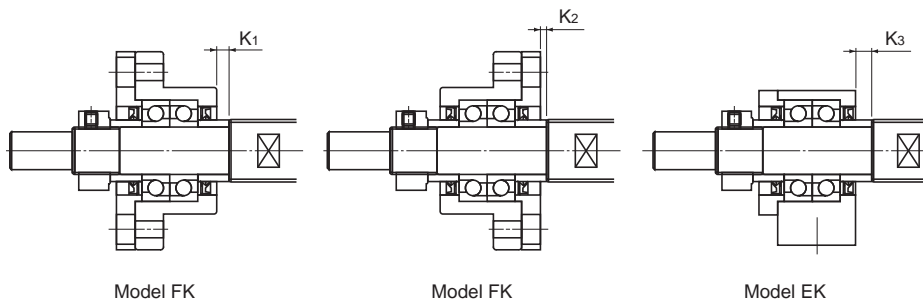

Support Unit model No.		Ball screw shaft outer diameter d	Shaft outer diameter of the bearing A	B	E	F	Metric screw thread	
Model FK	Model EK						M	S
FK4	EK4	6	4	3	23	5	M4×0.5	7
FK5	EK5	8	5	4	25	6	M5×0.5	7
FK6	EK6	10*1	6	4	30	8	M6×0.75	8
FK8	EK8	12	8	6	35	9	M8×1	10
FK10	EK10	14	10	8	36	15	M10×1	11
FK10	EK10	15	10	8	36	15	M10×1	11
FK12	EK12	16	12	10	36	15	M12×1	11
FK12	EK12	18	12	10	36	15	M12×1	11
FK15	EK15	20	15	12	49	20	M15×1	13
FK15	EK15	25	15	12	49	20	M15×1	13
FK20	EK20	28	20	17	64	25	M20×1	17
FK20	EK20	30	20	17	64	25	M20×1	17
FK20	EK20	32	20	17	64	25	M20×1	17
FK25	—	36	25	20	76	30	M25×1.5	20
FK30	—	40	30	25	72	38	M30×1.5	25

Note) Support Units are designed to have dimensions so that combinations of models FK and FF, models EK and EF or models BK and BF are used on the same shaft.

If desiring the shaft end to be machined at THK, add the shape symbol in the end of the Ball Screw model number.

(Example) TS2505+500L-H2K

(Shape H2 on the fixed side; shape K on the supported side)

For the perpendicularity of the end face of the bearing, refer to JIS B 1192-1997.

*1 FK6 and EK6 also support $\phi 8$ mm outer diameter ball screws. Contact THK for details.

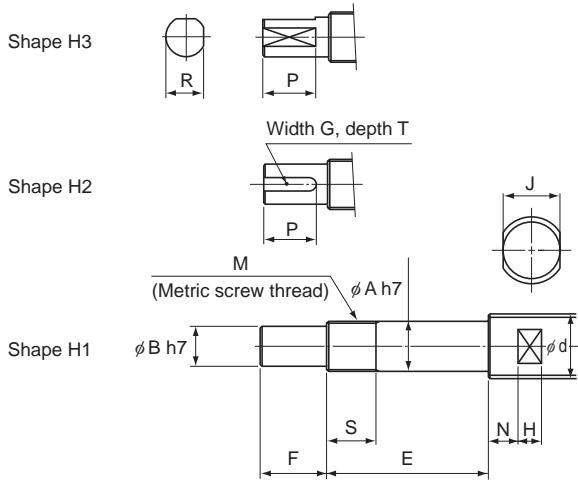

Unit: mm

	Width across flat			Shape H2 Keyway			Shape H3 Cut flat on two side		Support Unit position		
									Model FK		Model EK
	J	N	H	G N9	T +0.1 0	P	R	P	K ₁	K ₂	
	4	4	4	—	—	—	2.7	4	1.5	0.5	1.5
	5	4	4	—	—	—	3.7	5	2	0.5	2
	5	4	4	—	—	—	3.7	6	3.5	0.5	3.5
	8	5	5	—	—	—	5.6	7	3.5	0.5	3.5
	10	5	7	2	1.2	11	7.5	11	0.5	-0.5	-0.5
	10	5	7	2	1.2	11	7.5	11	0.5	-0.5	-0.5
	13	6	8	3	1.8	12	9.5	12	0.5	-0.5	-0.5
	13	6	8	3	1.8	12	9.5	12	0.5	-0.5	-0.5
	16	6	9	4	2.5	16	11.3	16	4	2	5
	18	7	10	4	2.5	16	11.3	16	4	2	5
	21	8	11	5	3	21	16	21	1	-3	1
	24	8	12	5	3	21	16	21	1	-3	1
	27	9	13	5	3	21	16	21	1	-3	1
	27	10	13	6	3.5	25	19	25	5	-2	—
	32	10	15	8	4	32	23.5	32	-3	-9	—

Note) The ball nut flange faces the fixed side unless otherwise specified.

If desiring the flange to face the supported side, add symbol G in the end of the Ball Screw model number when placing an order.

(Example) BIF2505-5RRGO+420LC5-H2KG

Recommended Shapes of Shaft Ends - Shape J (J1, J2 and J3) (For Support Unit Model BK)

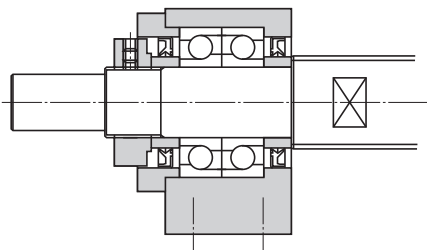

Model BK

Support Unit model No. Model BK	Ball screw shaft outer diameter d	Shaft outer diameter of the bearing A	B	E	F	Metric screw thread
						M
BK10	14	10	8	39	15	M10×1
BK10	15	10	8	39	15	M10×1
BK12	16	12	10	39	15	M12×1
BK12	18	12	10	39	15	M12×1
BK15	20	15	12	40	20	M15×1
BK17	25	17	15	53	23	M17×1
BK20	28	20	17	53	25	M20×1
BK20	30	20	17	53	25	M20×1
BK20	32	20	17	53	25	M20×1
BK25	36	25	20	65	30	M25×1.5
BK30	40	30	25	72	38	M30×1.5
BK35	45	35	30	83	45	M35×1.5
BK40	50	40	35	98	50	M40×1.5
BK40	55	40	35	98	50	M40×1.5

Note) Support Units are designed to have dimensions so that combinations of models FK and FF, models EK and EF or models BK and BF are used on the same shaft.

If desiring the shaft end to be machined at THK, add the shape symbol in the end of the Ball Screw model number.

(Example) TS2505+500L-J2K

(Shape J2 on the fixed side; shape K on the supported side)

For the perpendicularity of the end face of the bearing, refer to JIS B 1192-1997.

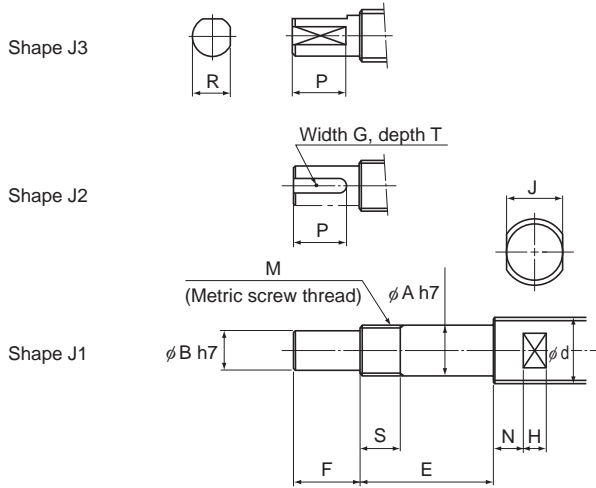

Unit: mm

	Width across flat				Shape J2 Keyway			Shape J3 Cut flat on two side	
	S	J	N	H	G N9	T +0.1 0	P	R	P
	16	10	5	7	2	1.2	11	7.5	11
	16	10	5	7	2	1.2	11	7.5	11
	14	13	6	8	3	1.8	12	9.5	12
	14	13	6	8	3	1.8	12	9.5	12
	12	16	6	9	4	2.5	16	11.3	16
	17	18	7	10	5	3	21	14.3	21
	15	21	8	11	5	3	21	16	21
	15	24	8	12	5	3	21	16	21
	15	27	9	13	5	3	21	16	21
	18	27	10	13	6	3.5	25	19	25
	25	32	10	15	8	4	32	23.5	32
	28	36	12	15	8	4	40	28.5	40
	35	41	14	19	10	5	45	33	45
	35	46	14	20	10	5	45	33	45

Note) The ball nut flange faces the fixed side unless otherwise specified.

If desiring the flange to face the supported side, add symbol G in the end of the Ball Screw model number when placing an order.

(Example) BIF2505-5RRGO+420LC5-J2KG

Recommended Shapes of Shaft Ends - Shape K (For Support Unit Models FF, EF and BF)

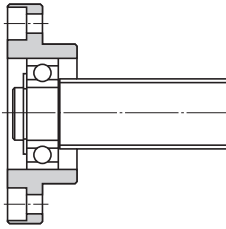

Model FF

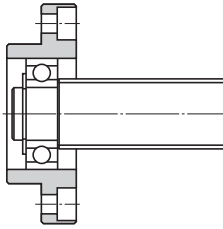

Model FF

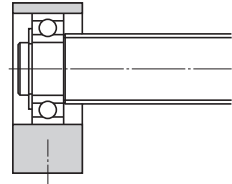

Model EF

Model BF

Support Unit model No.			Ball screw shaft outer diameter	Shaft outer diameter of the bearing
Model FF	Model EF	Model BF		
FF6	EF6	—	8	6
—	EF8	—	12	6
FF10	EF10	BF10	14	8
FF10	EF10	BF10	15	8
FF12	EF12	BF12	16	10
FF12	EF12	BF12	18	10
FF15	EF15	BF15	20	15
FF15	EF15	BF15	25	15
—	—	BF17 *		17
FF20	EF20	BF20 **	28	20
FF20	EF20	BF20 **	30	20
FF20	EF20	BF20 **	32	20
FF25	—	BF25	36	25
FF30	—	BF30	40	30
—	—	BF35	45	35
—	—	BF40	50	40
—	—	BF40	55	40

Note) Support Units are designed to have dimensions so that combinations of models FK and FF, models EK and EF or models BK and BF are used on the same shaft.

If desiring the shaft end to be machined at THK, add the shape symbol in the end of the Ball Screw model number.

(Example) TS2505+500L-H2K

(Shape H2 on the fixed side; shape K on the supported side)

For the perpendicularity of the end face of the bearing, refer to JIS B 1192-1997.

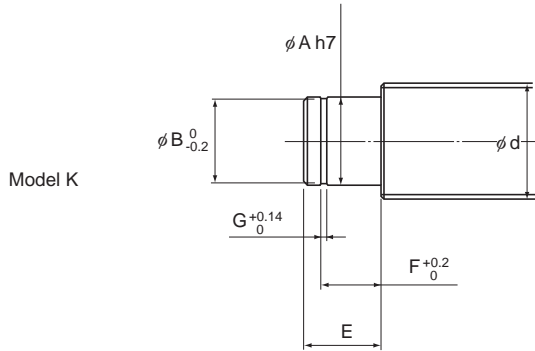

Unit: mm

	E	Snap ring groove		
		B	F	G
	9	5.7	6.8	0.8
	9	5.7	6.8	0.8
	10	7.6	7.9	0.9
	10	7.6	7.9	0.9
	11	9.6	9.15	1.15
	11	9.6	9.15	1.15
	13	14.3	10.15	1.15
	13	14.3	10.15	1.15
	16	16.2	13.15	1.15
	19 (16)	19	15.35 (13.35)	1.35
	19 (16)	19	15.35 (13.35)	1.35
	19 (16)	19	15.35 (13.35)	1.35
	20	23.9	16.35	1.35
	21	28.6	17.75	1.75
	22	33	18.75	1.75
	23	38	19.95	1.95
	23	38	19.95	1.95

Note) *When model BK17 (shaft end shape: J) is used on the fixed side for a Ball Screw with a shaft outer diameter of 25 mm, the shaft end shape on the supported side is that for model BF17.

**The dimensions in the parentheses in the table above are that of model BF20. They differ from those of models FF20 and EF20. When placing an order, be sure to specify the model number of the Support Unit to be used.

Nut Bracket

Model MC

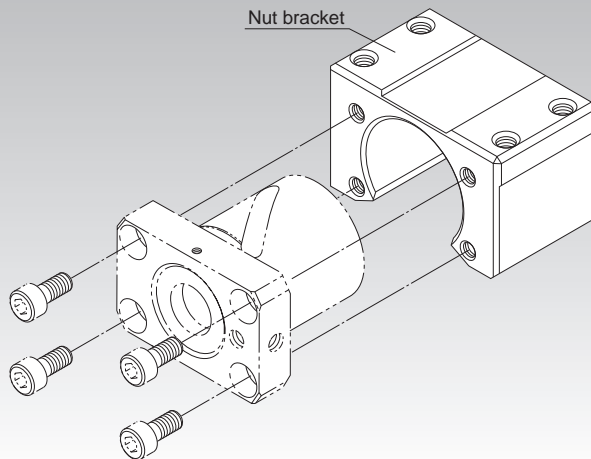

Fig.1 Structure of the Nut Bracket

Structure and Features

The model MC nut bracket is designed for use with BNK finished shaft end precision ball screw nuts. Its low height and the fact that it can be assembled using only bolts means devices can be compact and reduces how long they take to put together.

Type

Nut Bracket Model MC

Specification Table⇒ [A15-331](#)

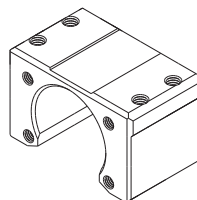

Nut Bracket

Model No.	Supported Ball Screw models
MC 1004	BNK1004,BNK1010
MC 1205	BNK1205
MC 1408	BNK1408,BNK1510,BNK1520,BNK1616
MC 2010	BNK2010
MC 2020	BNK2020

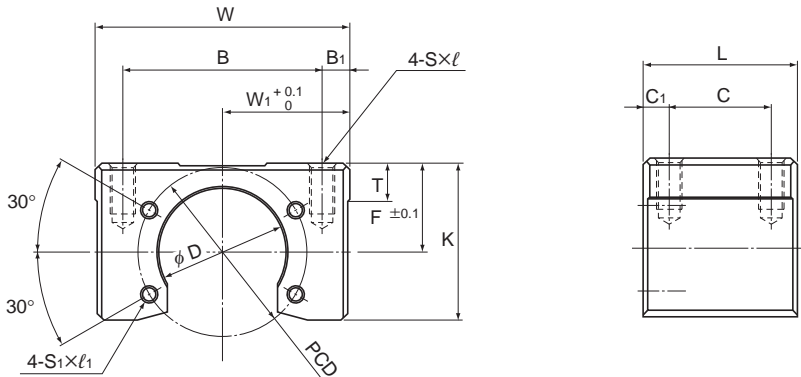

Unit: mm

Model No.	Width W	W_1	B	B_1	Overall length L	C	C_1	F	K
MC 1004	48	24	40	4	32	16	10	20	32.5
MC 1205	60	30	47	6.5	36	24	6	21	37
MC 1408	60	30	50	5	36	20	10	21.5	37
MC 2010	86	43	70	8	50	30	10	31	54
MC 2020	86	43	70	8	40	24	8	28	51

Model No.	T	D	PCD	$S \times \ell$	$S_1 \times \ell_1$	Mass kg
MC 1004	9	26.4	36	M5×10	M4×7	0.24
MC 1205	9	30.4	40	M6×12	M4×7	0.38
MC 1408	9	34.4	45	M6×12	M5×7	0.34
MC 2010	16	46.4	59	M10×20	M6×10	1.04
MC 2020	16	39.4	59	M10×20	M6×10	0.83

Lock Nut

Model RN

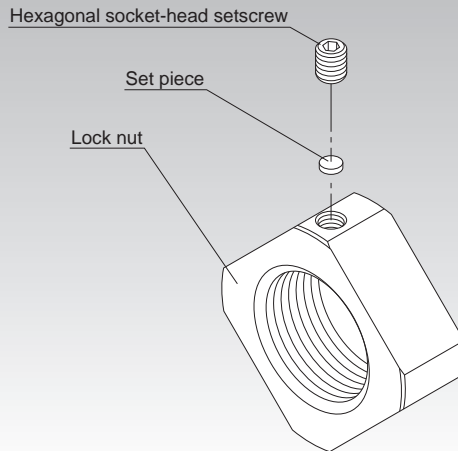

Fig.1 Structure of the Lock Nut

Structure and Features

The model RN ball screw lock nut is used for fixing the angular bearings that set into ball screws. It can be fixed in place with the hexagonal socket set screws using a set piece. This does not deform the thread at the end of the ball screw shaft. This can be reused. Available in sizes M4 to M40. Screw pitches must be narrow.

Type

Lock Nut Model RN

Specification Table⇒ **A15-333**

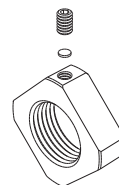

Lock Nut

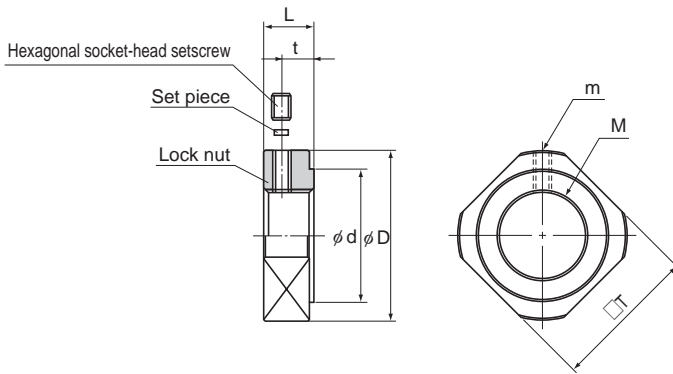

Unit: mm

Model No.	M	m	D	d	L	t	T	Mass kg
RN 4	M4×0.5	M2.6	11.5	8	5	2.7	10	0.003
RN 5	M5×0.5	M2.6	13.5	9	5	2.7	11	0.004
RN 6	M6×0.75	M3	14.5	10	5	2.7	12	0.005
RN 8	M8×1	M3	17	13	6.5	4	14	0.008
RN 10	M10×1	M3	20	15	8	5.5	16	0.013
RN 12	M12×1	M3	22	17	8	5.5	19	0.014
RN 15	M15×1	M3	25	21	8	4.5	22	0.017
RN 17	M17×1	M4	30	25	13	9	24	0.042
RN 20	M20×1	M4	35	26	11	7	30	0.048
RN 25	M25×1.5	M5	43	33	15	10	35	0.096
RN 30	M30×1.5	M6	48	39	20	14	40	0.145
RN 35	M35×1.5	M8	60	46	21	14	50	0.261
RN 40	M40×1.5	M8	63	51	25	18	50	0.304

Ball Screw Options

Contaminaton Protection

If foreign material enters the interior of the ball screw, abnormal levels of abrasion and ball clogging are more likely to occur. This can also shorten the overall lifespan of the product.

As such, foreign material needs to be prevented from entering. If there is a chance that foreign material may get in, it is important to choose an effective contamination protection product that suits the usage conditions.

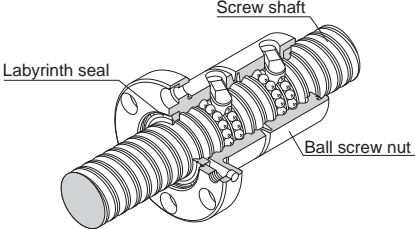
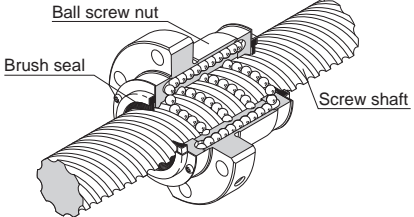
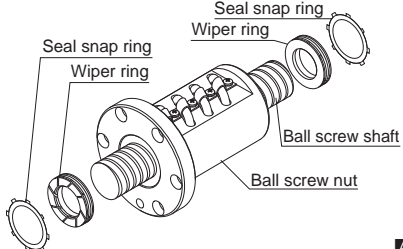
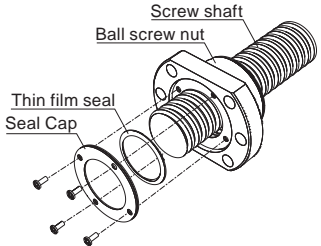
<p>Labyrinth seal (Precision Ball Screw) (Rolled Ball Screw Model JPF) Symbol: RR</p>	 <p style="text-align: right;">A15-338</p>
<p>Brush seal (Rolled Ball Screw) Symbol: ZZ</p>	 <p style="text-align: right;">A15-338</p>
<p>Wiper ring Symbol: WW</p>	 <p style="text-align: right;">A15-339~</p>
<p>Thin film seal (SDA-V only) Symbol: TT</p>	

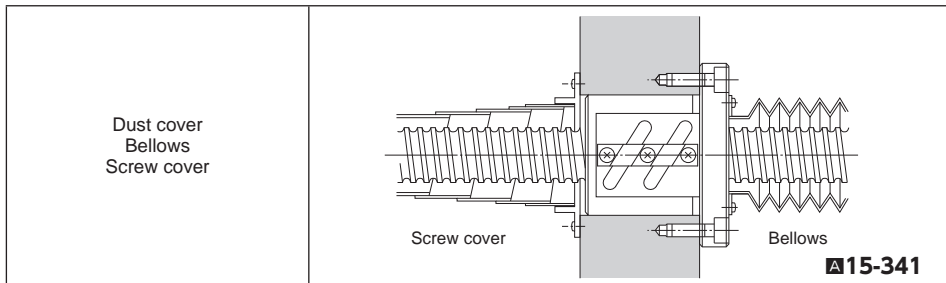

Lubrication

To maximize the performance of the Ball Screw, it is necessary to select a lubricant and a lubrication method according to the conditions.

For types of lubricants, characteristics of lubricants and lubrication methods, see the section on “Accessories for Lubrication” on **A24-2**.

Also, QZ Lubricator is available as an optional accessory that significantly increases the maintenance interval.

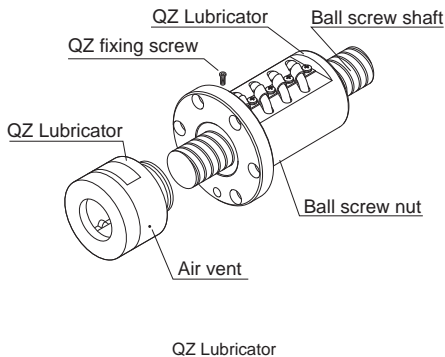

Corrosion Resistance (Surface Treatment, etc.)

Depending on the service environment, the Ball Screw requires corrosion resistance treatment or a different material. For details of corrosion resistance treatment and material change, contact THK. (see **B0-18**)

Contamination Protection Seal for Ball Screws

If the Ball Screw is used in an atmosphere free from foreign material but with suspended dust, a labyrinth seal (with symbol RR) and a brush seal (with symbol ZZ) can be used as contamination protection accessories.

The labyrinth seal is designed to maintain a slight clearance between the seal and the screw shaft raceway so that torque does not develop and no heat is generated, though its effect in contamination protection is limited.

With Ball Screws except the large lead and super lead types, there is no difference in nut dimensions between those with and without a seal.

Labyrinth seal

Symbol: RR (Precision Ball Screw)
(Rolled Ball Screw Model JPF)

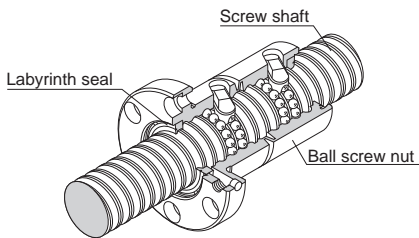

Labyrinth seal

Brush seal

Symbol: ZZ (Rolled Ball Screw)

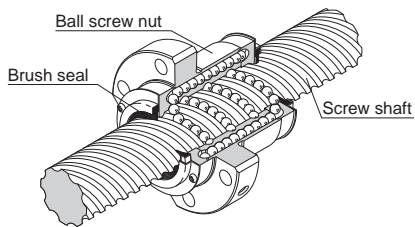

Brush seal

Wiper Ring W

● For the supported models and the ball screw nut dimension with Wiper ring W attached, see [A15-344](#) to [A15-351](#).

With the wiper ring W, special resin with high wear resistance and low dust generation removes foreign material and prevents foreign material from entering the ball screw nut while elastically contacting the circumference of the ball screw shaft and the screw thread.

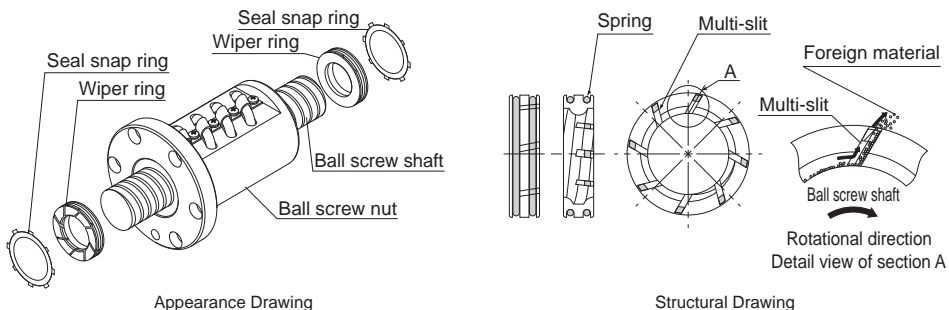

[Features]

- A total of eight slits on the circumference remove foreign materials in succession, and prevent entrance of foreign material.
- Contacts the ball screw shaft to reduce the flowing out of grease.
- Contacts the ball screw shaft at a constant pressure level using a spring, thus to minimize the heat generation.
- Since the material is highly resistant to the wear and the chemicals, its performance will not easily be deteriorated even if it is used over a long period.

Can be attached together with QZ Lubricator.

For the applicable models and the ball screw nut dimensions after wiper ring W is attached, see [A15-344](#).

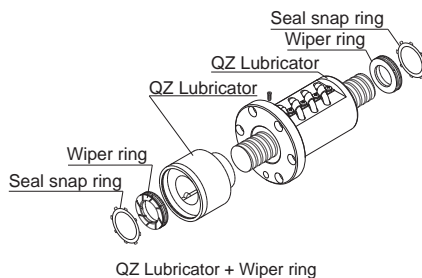

Model number coding

BIF2505V-5 QZ WW G0 +1000L C5

With QZ
Lubricator

With wiper ring W

(*) See [A15-344](#).

● Test in an environment exposed to contaminated environment

[Test conditions]

Item	Description
Model No.	BIF3210V-5G0+1500LC5
Maximum rotational speed	1000min ⁻¹
Maximum speed	10m/min
Maximum circumferential speed	1.8m/s
Time constant	60ms
Dowel	1s
Stroke	900mm
Load (through internal load)	1.31kN
Grease	THK AFG Grease 8cm ³ (Initial lubrication to the ball screw nut only.)
Foundry dust	FCD400 average particle diameter: 250μm
Volume of foreign material per shaft	5g/h

[Test result]

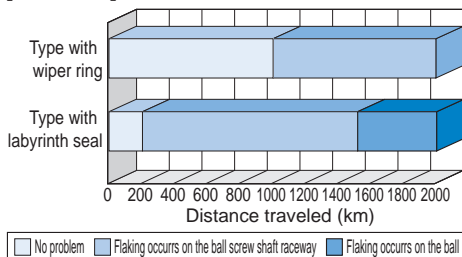

- Type with wiper ring
Slight flaking occurred in the ball screw shaft at travel distant of 1,000 km.
- Type with labyrinth seal
Flaking occurred throughout the circumference of the screw shaft raceway at travel distance of 200 km.
Flaking occurred on the balls after traveling 1,500 km.

Change in the ball after traveling 2000 km

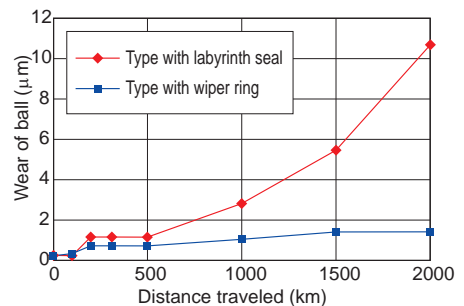
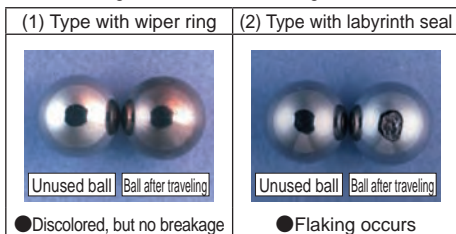

- Type with wiper ring
Wear of balls at a travel distance of 2,000 km: 1.4 μm.
- Type with labyrinth seal
Starts to be worn rapidly after 500 km, and the ball wear amount at the travel distance of 2,000 km: 11 μm.

● Heat Generation Test

[Test conditions]

Item	Description
Model No.	BLK3232-3.6G0+1426LC5
Maximum rotational speed	1000min ⁻¹
Maximum speed	32m/min
Maximum circumferential speed	1.7m/s
Time constant	100ms
Stroke	1000mm
Load (through internal load)	0.98kN
Grease	THK AFG Grease 5cm ³ (contained in the ball screw nut)

[Test result]

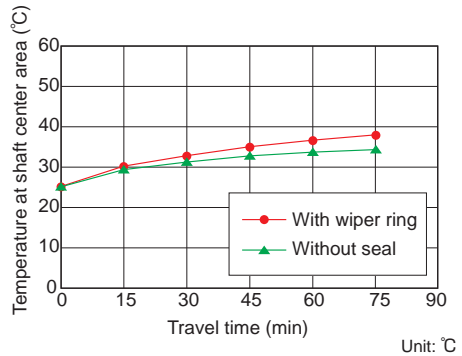

Item	With wiper ring	Without seal
Heat generation temperature	37.1	34.5
Temperature rise	12.2	8.9

Dust Cover for Ball Screws

Bellows/Screw cover

In the case of an environment with much dust and foreign material, be sure to prevent intrusion of foreign material by using bellows, a screw cover or the like. The contamination protection can be increased by also using a contamination protection seal. For details, contact THK. When conferring with us, please use the bellows specifications (A15-352).

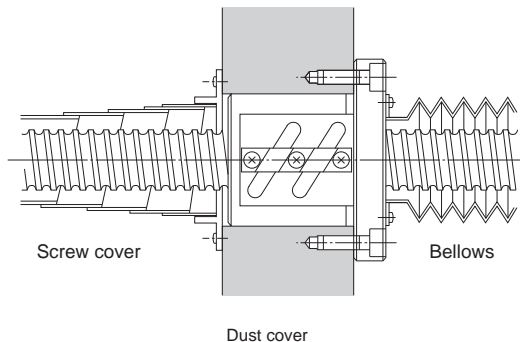

QZ Lubricator

● For the supported models and the ball screw nut dimension with QZ attached, see [A15-344](#) to [A15-351](#).

QZ Lubricator feeds a right amount of lubricant to the raceway of the ball screw shaft. This allows an oil film to be constantly formed between the balls and the raceway, improves lubricity and significantly extends the lubrication maintenance interval.

The structure of QZ Lubricator consists of three major components: (1) a heavily oil-impregnated fiber net (stores the lubricant), (2) a high-density fiber net (applies the lubricant to the raceway) and (3) an oil-control plate (adjusts the oil flow). The lubricant contained in the QZ Lubricator is fed by the capillary phenomenon, which is used also in felt pens and many other products.

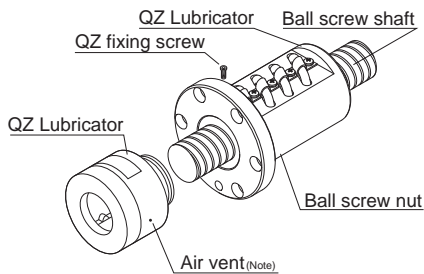

Appearance Drawing

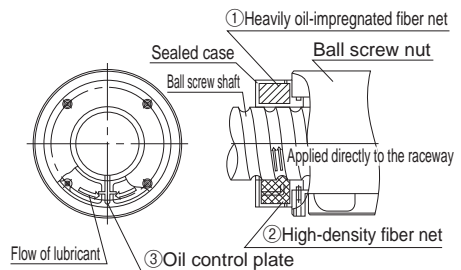

Structural Drawing

[Features]

- Since it supplements an oil loss, the lubrication maintenance interval can be significantly extended.
- Since the right amount of lubricant is applied to the ball raceway, an environmentally friendly lubrication system that does not contaminate the surroundings is achieved.

Note) Some types of QZ have a vent hole. Be careful not to block the hole with grease or other obstructions.

Model number coding

BIF2505V-5 QZ WW G0 +1000L C5

With QZ
Lubricator

With wiper ring W

(*) See [A15-344](#).

● Significantly extended maintenance interval

Since QZ Lubricator continuously feeds a lubricant over a long period, the maintenance interval can be significantly extended.

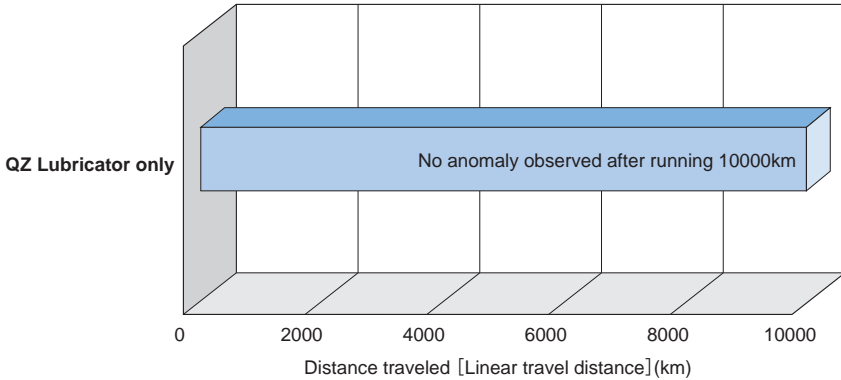

[Test conditions]

Item	Description
Ball Screw	BIF2510V
Maximum rotational speed	2500min ⁻¹
Maximum speed	25m/min
Stroke	500mm
Load	Internal preload only

● Environmentally friendly lubrication system

Since QZ Lubricator feeds the right amount of lubricant directly to the raceway, the lubricant can effectively be used without waste.

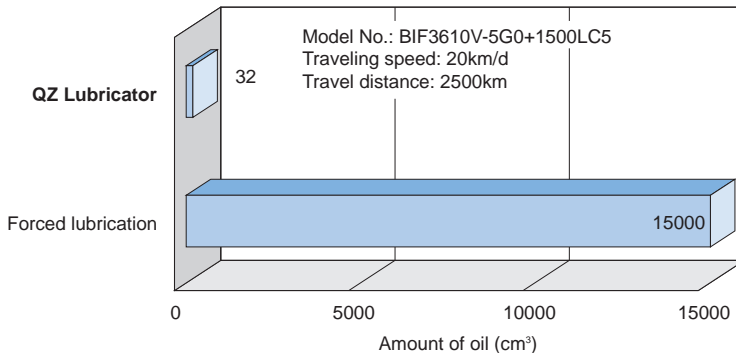

QZ Lubricator + THK AFA Grease

32cm³

(QZ Lubricator attached to both ends of the ball screw nut)



Forced lubrication

0.25cm³/3min×24h×125d
=15000cm³

Reduced to approx. $\frac{1}{470}$

Dimensions of Each Model with an Option Attached

Dimensions of the Ball Screw Nut Attached with Wiper Ring W and QZ Lubricator

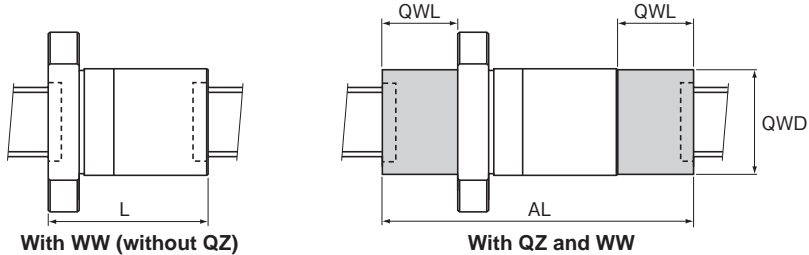

Unit: mm

Unit: mm

Model No.	WW availability	QZ availability	Dimensions including WW		Length of protrusion with QZ attached	Outer diameter of protrusion with QZ attached	Dimensions including QZ and WW
			L	QWL			
EBA EBB EBC DIN Standard	1605-4	○	○	50	25	27	110
	2005-3	○	○	45	26.5	33	98
	2505-3	○	○	45	28	39	101
	2510-3	○	○	75	32	39	139
	2510-4	○	○	80	32	39	144
	3205-3	○	○	47	35	45	117
	3205-4	○	○	52	35	45	122
	3205-6	○	○	62	35	45	132
	3210-3	○	○	77	40	49	157
	3210-4	○	○	89	40	49	169
	4005-6	○	○	65	28.5	61	122
	4010-3	○	○	79	44	61	167
	4010-4	○	○	89	44	61	177
	4020-3	○	○	119	47	61	213
	5010-4	○	○	91	37	71	165
5020-3	○	○	124	40	71	204	
6310-6	○	○	114	39	84	192	
6320-3	○	○	126	30.5	94	187	
EPA EPB EPC DIN Standard	1605-6	○	○	60	25	27	115
	2005-6	○	○	61	26.5	33	114
	2505-6	○	○	61	28	39	117
	2510-4	○	○	80	32	39	144
	3205-6	○	○	62	35	45	132
	3205-8	○	○	73	35	45	143
	3210-6	○	○	107	40	49	187
	4005-6	○	○	65	28.5	61	122
	4010-6	○	○	109	44	61	197
	4010-8	○	○	133	44	61	221
	5010-8	○	○	135	37	71	209
6310-8	○	○	137	39	84	215	

Model No.	WW availability	QZ availability	Dimensions including WW		Length of protrusion with QZ attached	Outer diameter of protrusion with QZ attached	Dimensions including QZ and WW
			L	QWL			
SBN Small Retainer	1604V-5	○	○	53	29	31	111
	1605V-5	○	○	56	29	31	114
	2004V-5	○	○	49	27.5	39	104
	2005V-5	○	○	56	27.5	43	111
	2010V-5	△	△	—	—	—	—
	2504V-5	○	○	48	32.5	45	113
	2505V-5	○	○	55	32.5	45	120
	2506V-5	○	○	62	33	45	128
	2805V-5	○	○	59	22	54	103
	3205V-5	○	○	56	32	57	120
	3206V-5	○	○	63	32	57	127
	2508V-7	○	○	98	34	45	166
	2510V-5	○	○	100	37	45	174
	2810V-3	○	△	88	—	—	154
	3210V-7	○	○	120	31	73	182
3212V-5	○	○	117	33	73	183	
SBN Medium Retainer	3216V-5	△	△	—	—	—	—
	3610V-7	○	○	123	33	64	189
	3612V-7	○	○	140	35	64	210
	3616V-5	○	○	140	32	64	204
	3620V-3	○	○	122	32	64	186
	4010V-5	○	○	103	37	66	177
	4012V-5	○	○	119	38	66	195
	4016V-5	○	○	144	42	66	228
	4020V-5	△	△	—	—	—	—
	4510V-5	○	△	111	—	—	—
	4512V-5	○	○	119	35.5	79	190
	4516V-5	○	○	140	35.5	79	211
	4520V-5	△	△	—	—	—	—
	5010V-5	○	○	103	37.5	79	178
	5012V-5	○	○	123	38.5	79	200
5016V-5	○	○	164	38.5	79	241	
5020V-5	○	○	201	40.5	79	282	

○: available △: available per request ×: not available

*Please contact THK for more information regarding the model numbers which do not support WW and QZ.

(Note) The L dimension indicates the length of the nut with WW.

For models BLW, BLK (precision and rolling), WGF, BNK1510 or larger (excluding BNK2010), WTF and CNF, fit a wiper ring to the outside of the nut.

Options

Dimensions of Each Model with an Option Attached

Unit: mm

Model No.	WW availability	QZ availability	Dimensions including WW		Length of protrusion with QZ attached		Outer diameter of protrusion with QZ attached	Dimensions including QZ and WW
			L	QWL	QWD	AL		
SBK Retainer	1520-3.6	△	○	—	22	31	98	
	1616-3.6	△	×	—	—	—	—	
	2010-5.6	△	○	—	27	36	99	
	2020-3.6	○	○	54	27	36	108	
	2030-3.6	△	○	—	27	36	125	
	2520-3.6	○	○	57	35.5	44	128	
	2525-3.6	○	○	68	35.5	44	139	
	3220-5.6	○	○	82	34.5	53	151	
	3232-5.6	△	○	—	34.5	53	187	
	3620-7.6	○	○	110	28	69	166	
	3636-5.6	○	○	134	28	69	190	
	4020-7.6	○	○	110	30.5	79	171	
	4030-7.6	○	○	148	30.4	79	208.8	
	4040-5.6	○	○	146	30.4	79	206.8	
	5020-7.6	○	○	110	35	89	180	
	5030-7.6	○	○	149	35	89	219	
	5036-7.6	○	○	172	35	89	242	
5050-5.6	○	○	175	35	89	245		
5520-7.6	○	○	110	32	95	174		
5530-7.6	○	○	149	32	95	213		
5536-7.6	○	○	172	32	95	236		
SDA Retainer	1505V-3	×	×	—	—	—	—	
	1510V-3	×	×	—	—	—	—	
	1520V-4	×	×	—	—	—	—	
	1530V-4	×	×	—	—	—	—	
	1605V-3	×	×	—	—	—	—	
	1610V-3	×	×	—	—	—	—	
	1616V-3	×	×	—	—	—	—	
	2005V-3	×	×	—	—	—	—	
	2010V-3	×	×	—	—	—	—	
	2020V-3	×	×	—	—	—	—	
	2030V-2	×	×	—	—	—	—	
	2040V-2	×	×	—	—	—	—	
	2505V-3	×	×	—	—	—	—	
	2510V-3	×	×	—	—	—	—	
	2520V-3	×	×	—	—	—	—	
	2525V-3	×	×	—	—	—	—	
	2530V-2	×	×	—	—	—	—	
	2550V-2	×	×	—	—	—	—	
	3110V-5	×	×	—	—	—	—	
	3112V-5	×	×	—	—	—	—	
3116V-5	×	×	—	—	—	—		
3120V-5	×	×	—	—	—	—		
3132V-2	×	×	—	—	—	—		
3610V-5	×	×	—	—	—	—		
3612V-5	×	×	—	—	—	—		
3616V-5	×	×	—	—	—	—		
3620V-5	×	×	—	—	—	—		

○: available △: available per request ×: not available

*Please contact THK for more information regarding the model numbers which do not support WW and QZ.

Unit: mm

Model No.	WW availability	QZ availability	Dimensions including WW		Length of protrusion with QZ attached		Outer diameter of protrusion with QZ attached	Dimensions including QZ and WW
			L	QWL	QWD	AL		
SDA Retainer	3636V-2	×	×	—	—	—	—	
	3810V-5	×	×	—	—	—	—	
	3812V-5	×	×	—	—	—	—	
	3816V-5	×	×	—	—	—	—	
	3820V-5	×	×	—	—	—	—	
	3825V-4	×	×	—	—	—	—	
	3830V-3	×	×	—	—	—	—	
	3840V-2	×	×	—	—	—	—	
	4510V-5	×	×	—	—	—	—	
	4512V-5	×	×	—	—	—	—	
	4516V-5	×	×	—	—	—	—	
	4520V-5	×	×	—	—	—	—	
	4525V-4	×	×	—	—	—	—	
	4530V-4	×	×	—	—	—	—	
	4540V-3	×	×	—	—	—	—	
	5010V-5	×	×	—	—	—	—	
	5012V-5	×	×	—	—	—	—	
	5016V-5	×	×	—	—	—	—	
	5020V-5	×	×	—	—	—	—	
	5025V-4	×	×	—	—	—	—	
HBN Retainer	5030V-4	×	×	—	—	—	—	
	5040V-3	×	×	—	—	—	—	
	5050V-2	×	×	—	—	—	—	
	3210-5	×	△	—	—	—	—	
	3610-5	×	△	—	—	—	—	
	3612-5	×	△	—	—	—	—	
	4010-7.5	×	△	—	—	—	—	
	4012-7.5	×	△	—	—	—	—	
	5010-7.5	×	△	—	—	—	—	
	5012-7.5	×	△	—	—	—	—	
SBKH Retainer	5016-7.5	×	△	—	—	—	—	
	6316-7.5	×	△	—	—	—	—	
	6316-10.5	×	△	—	—	—	—	
	6320-7.5	×	△	—	—	—	—	
	6332-3.8	×	△	—	—	—	—	
	6340-7.6	×	△	—	—	—	—	
	8050-7.6	×	△	—	—	—	—	
	8060-7.6	×	△	—	—	—	—	
	10050-7.6	×	△	—	—	—	—	
	10060-7.6	×	△	—	—	—	—	
BNF Small	12060-7.6	×	△	—	—	—	—	
	1604V-5	○	○	53	29	31	111	
	1605V-2.5	○	○	41	29	31	99	
	1605V-5	○	○	56	29	31	114	
	2004V-2.5	○	○	37	27.5	39	92	
	2004V-5	○	○	49	27.5	39	104	
	2005V-2.5	○	○	41	27.5	43	96	
2005V-5	○	○	56	27.5	43	111		

Unit: mm

Model No.	WW availability	QZ availability	Dimensions including WW		Length of protrusion with QZ attached	Outer diameter of protrusion with QZ attached	Dimensions including QZ and WW	
			L	QWL				QWD
BNF Small	2010V-2.5	△	△	—	—	—	—	
	2504V-2.5	○	○	36	32.5	45	101	
	2504V-5	○	○	48	32.5	45	113	
	2505V-2.5	○	○	40	32.5	45	105	
	2505V-5	○	○	55	32.5	45	120	
	2506V-2.5	○	○	44	33	45	110	
	2506V-5	○	○	62	33	45	128	
	2805V-2.5	○	○	44	22	54	88	
	2805V-5	○	○	59	22	54	103	
	2805V-7.5	○	○	74	22	54	118	
	2806V-2.5	○	△	50	—	—	—	
	2806V-5	○	△	68	—	—	—	
	2806V-7.5	○	△	86	—	—	—	
	3205V-2.5	○	○	41	32	57	105	
	3205V-5	○	○	56	32	57	120	
	3205V-7.5	○	○	71	32	57	135	
	3206V-2.5	○	○	45	32	57	109	
	3206V-5	○	○	63	32	57	127	
	BNF Medium	2508V-2.5	○	○	58	34	45	126
		2508V-3.5	○	○	66	34	45	134
2508V-5		○	○	82	34	45	150	
2510V-2.5		○	○	70	37	45	144	
2810V-2.5		○	△	86	—	—	—	
3210V-2.5		○	○	70	31	73	132	
3210V-3.5		○	○	80	31	73	142	
3210V-5		○	○	100	31	73	162	
3212V-3.5		○	○	98	33	73	164	
3216V-5		△	△	—	—	—	—	
3610V-2.5		○	○	81	33	64	147	
3610V-5		○	○	111	33	64	177	
3610V-7.5		○	○	141	33	64	207	
3612V-2.5		○	○	87	35	64	157	
3612V-5		○	○	123	35	64	193	
3616V-2.5		○	○	92	32	64	156	
3620V-1.5		○	○	82	32	64	146	
4010V-2.5		○	○	73	37	66	147	
4010V-3.5		○	○	83	37	66	157	
4010V-5		○	○	103	37	66	177	
4012V-2.5		○	○	83	38	66	159	
4012V-3.5		○	○	95	38	66	171	
4012V-5		○	○	119	38	66	195	
4016V-5		○	○	144	42	66	228	
4020V-5		△	△	—	—	—	—	
4510V-2.5		○	△	81	—	—	152	
4510V-3		○	△	94	—	—	165	
4510V-5		○	△	111	—	—	182	
4510V-7.5	○	△	141	—	—	212		
4512V-5	○	○	119	35.5	79	190		

Unit: mm

Model No.	WW availability	QZ availability	Dimensions including WW		Length of protrusion with QZ attached	Outer diameter of protrusion with QZ attached	Dimensions including QZ and WW	
			L	QWL				QWD
BNF Medium	4520V-2.5	△	△	—	—	—	—	
	5010V-2.5	○	○	73	37.5	79	148	
	5010V-3.5	○	○	83	37.5	79	158	
	5010V-5	○	○	103	37.5	79	178	
	5010V-7.5	○	○	133	37.5	79	208	
	5012V-2.5	○	○	87	38.5	79	164	
	5012V-3.5	○	○	99	38.5	79	176	
	5012V-5	○	○	123	38.5	79	200	
	5016V-2.5	○	○	116	38.5	79	193	
	5016V-5	○	○	164	38.5	79	241	
	5020V-2.5	○	○	141	40.5	79	222	
	BNF	5510-2.5	○	△	81	—	—	—
		5510-5	○	△	111	—	—	—
		5510-7.5	○	△	141	—	—	—
		5512-2.5	○	△	93	—	—	—
		5512-3	○	△	107	—	—	—
5512-3.5		○	△	105	—	—	—	
5512-5		○	△	129	—	—	—	
5512-7.5		○	△	165	—	—	—	
5516-2.5		○	△	116	—	—	—	
5516-5		○	△	164	—	—	—	
5520-2.5		○	△	127	—	—	—	
5520-5		○	△	187	—	—	—	
6310-2.5		○	△	77	—	—	—	
6310-5		○	△	107	—	—	—	
6310-7.5		○	△	137	—	—	—	
6312A-2.5		△	△	—	—	—	—	
6312A-5		△	△	—	—	—	—	
6316-5		△	△	—	—	—	—	
6320-2.5		○	△	127	—	—	—	
6320-5		○	△	187	—	—	—	
7010-2.5		△	△	—	—	—	—	
7010-5		△	△	—	—	—	—	
7010-7.5		△	△	—	—	—	—	
7012-2.5		△	△	—	—	—	—	
7012-5		△	△	—	—	—	—	
7012-7.5		△	△	—	—	—	—	
7020-5		△	△	—	—	—	—	
8010-2.5		△	△	—	—	—	—	
8010-5		△	△	—	—	—	—	
8010-7.5		△	△	—	—	—	—	
8020A-2.5		△	△	—	—	—	—	
8020A-5		△	△	—	—	—	—	
8020A-7.5	△	△	—	—	—	—		
10020A-2.5	○	△	131	—	—	—		
10020A-5	○	△	191	—	—	—		
10020A-7.5	○	△	251	—	—	—		

○: available △: available per request ×: not available

*Please contact THK for more information regarding the model numbers which do not support WW and QZ.

Options

Dimensions of Each Model with an Option Attached

Unit: mm

Unit: mm

Model No.	WW availability	QZ availability	Dimensions including WW		Length of protrusion with QZ attached		Outer diameter of protrusion with QZ attached	Dimensions including QZ and WW
			L	QWL	QWD	AL		
1605V-5	○	○	106	29	31	164		
2805V-7.5	○	○	134	22	54	178		
2806V-7.5	○	△	158	—	—	—		
3205V-7.5	○	○	136	32	57	200		
2810V-2.5	○	△	146	—	—	212		
3610V-7.5	○	○	261	33	64	327		
3616V-5	○	○	268	32	64	332		
4016V-5	○	○	280	42	66	364		
4510V-7.5	○	△	261	—	—	332		
5010V-7.5	○	○	253	37.5	79	328		
5510-2.5	○	△	141	—	—	—		
5510-5	○	△	201	—	—	—		
5510-7.5	○	△	261	—	—	—		
5512-2.5	○	△	165	—	—	—		
5512-3	○	△	191	—	—	—		
5512-3.5	○	△	189	—	—	—		
5512-5	○	△	237	—	—	—		
5512-7.5	○	△	309	—	—	—		
5516-2.5	○	△	196	—	—	—		
5516-5	○	△	292	—	—	—		
5520-2.5	○	△	227	—	—	—		
5520-5	○	△	347	—	—	—		
6310-2.5	○	△	137	—	—	—		
6310-5	○	△	197	—	—	—		
6310-7.5	○	△	257	—	—	—		
6312A-2.5	△	△	—	—	—	—		
6312A-5	△	△	—	—	—	—		
6316-2.5	△	△	—	—	—	—		
6316-5	△	△	—	—	—	—		
6320-2.5	○	△	227	—	—	—		
6320-5	○	△	347	—	—	—		
7010-2.5	△	△	—	—	—	—		
7010-5	△	△	—	—	—	—		
7010-7.5	△	△	—	—	—	—		
7012-2.5	△	△	—	—	—	—		
7012-5	△	△	—	—	—	—		
7012-7.5	△	△	—	—	—	—		
7020-5	△	△	—	—	—	—		
8010-2.5	△	△	—	—	—	—		
8010-5	△	△	—	—	—	—		
8010-7.5	△	△	—	—	—	—		
8012-5	△	△	—	—	—	—		
8020A-2.5	△	△	—	—	—	—		
8020A-5	△	△	—	—	—	—		
10020A-2.5	○	△	231	—	—	—		
10020A-5	○	△	351	—	—	—		
10020A-7.5	○	△	471	—	—	—		

Model No.	WW availability	QZ availability	Dimensions including WW		Length of protrusion with QZ attached		Outer diameter of protrusion with QZ attached	Dimensions including QZ and WW
			L	QWL	QWD	AL		
1604V-5	○	○	53	29	31	111		
1605V-5	○	○	56	29	31	114		
2004V-5	○	○	49	27.5	39	104		
2004V-10	○	○	73	27.5	39	128		
2005V-5	○	○	56	27.5	43	111		
2005V-10	○	○	86	27.5	43	141		
2010V-5	△	△	—	—	—	—		
2504V-5	○	○	48	32.5	45	113		
2504V-10	○	○	72	32.5	45	137		
2505V-5	○	○	55	32.5	45	120		
2505V-10	○	○	85	32.5	45	150		
2506V-5	○	○	62	33	45	128		
2506V-10	○	○	98	33	45	164		
2805V-5	○	○	59	22	54	103		
2805V-10	○	○	89	22	54	133		
2806V-5	○	△	68	—	—	—		
2806V-10	○	△	104	—	—	—		
3205V-5	○	○	56	32	57	120		
3205V-10	○	○	86	32	57	150		
3206V-5	○	○	63	32	57	127		
3206V-10	○	○	99	32	57	163		
2508V-5	○	○	82	34	45	150		
2508V-7	○	○	98	34	45	166		
2508V-10	○	○	130	34	45	198		
2510V-5	○	○	100	37	45	174		
2810V-3	○	△	88	—	—	—		
3210V-5	○	○	100	31	73	162		
3210V-7	○	○	120	31	73	182		
3210V-10	○	○	160	31	73	222		
3212V-5	○	○	117	33	73	183		
3212V-7	○	○	146	33	73	212		
3216V-5	△	△	—	—	—	—		
3610V-5	○	○	111	33	64	177		
3610V-7	○	○	123	33	64	189		
3610V-10	○	○	171	33	64	237		
3612V-5	○	○	123	35	64	193		
3612V-7	○	○	140	35	64	210		
3612V-10	○	○	195	35	64	265		
3616V-5	○	○	140	32	64	204		
3620V-3	○	○	122	32	64	186		
4010V-5	○	○	103	37	66	177		
4010V-7	○	○	123	37	66	197		
4010V-10	○	○	163	37	66	237		
4012V-5	○	○	119	38	66	195		
4012V-7	○	○	143	38	66	219		
4012V-10	○	○	191	38	66	267		
4016V-5	○	○	144	42	66	228		

Ball Screw (Options)

○: available △: available per request ×: not available

*Please contact THK for more information regarding the model numbers which do not support WW and QZ.

Unit: mm

Model No.	WW availability	QZ availability	Dimensions including WW		Length of protrusion with QZ attached	Outer diameter of protrusion with QZ attached	Dimensions including QZ and WW	
			L	QWL				QWD
BIF Medium	4020V-5	△	△	—	—	—	—	
	4510V-5	○	△	111	—	—	—	
	4510V-10	○	△	171	—	—	—	
	4512V-5	○	○	119	35.5	79	190	
	4512V-10	○	○	191	35.5	79	262	
	4516V-5	○	○	140	35.5	79	211	
	4520V-5	△	△	—	—	—	—	
	5010V-5	○	○	103	37.5	79	178	
	5010V-7	○	○	123	37.5	79	198	
	5010V-10	○	○	163	37.5	79	238	
	5012V-5	○	○	123	38.5	79	200	
	5012V-7	○	○	147	38.5	79	224	
	5012V-10	○	○	195	38.5	79	272	
	5016V-5	○	○	164	38.5	79	241	
	5016V-10	○	○	260	38.5	79	337	
	5020V-5	○	○	201	40.5	79	282	
	DIK	1404-4	△	×	—	—	—	—
		1404-6	△	×	—	—	—	—
1605-6		○	△	60	—	—	—	
2004-6		○	×	62	—	—	—	
2004-8		○	×	70	—	—	—	
2005-6		○	△	61	—	—	—	
2006-6		△	△	—	—	—	—	
2008-4		△	△	—	—	—	—	
2504-6		○	△	63	—	—	—	
2504-8		○	△	71	—	—	—	
2505-6		○	△	61	—	—	—	
2506-4		○	△	60	—	—	—	
2506-6		○	△	72	—	—	—	
2508-4		○	△	71	—	—	—	
2508-6		○	△	94	—	—	—	
2510-4		○	△	85	—	—	—	
2805-6		○	△	69	—	—	—	
2805-8		○	△	79	—	—	—	
2806-6		○	△	73	—	—	—	
2810-4		○	△	84	—	—	—	
3204-6		○	△	64	—	—	—	
3204-8		○	△	72	—	—	—	
3204-10		○	△	80	—	—	—	
3205-6		○	△	62	—	—	—	
3205-8		○	△	73	—	—	—	
3206-6		○	△	73	—	—	—	
3206-8		○	△	87	—	—	—	
3210-6		○	△	110	—	—	—	
3212-4		○	△	98	—	—	—	
3610-6		○	△	122	—	—	—	
3610-8		○	△	143	—	—	—	
3610-10		○	△	164	—	—	—	

Unit: mm

Model No.	WW availability	QZ availability	Dimensions including WW		Length of protrusion with QZ attached	Outer diameter of protrusion with QZ attached	Dimensions including QZ and WW	
			L	QWL				QWD
DIK	4010-6	○	○	113	44	61	201	
	4010-8	○	○	137	44	61	225	
	4012-6	○	○	138	44	61	226	
	4012-8	○	○	163	44	61	251	
	4016-4	○	○	120	44	61	208	
	5010-6	○	△	114	—	—	—	
	5010-8	○	△	137	—	—	—	
	5010-10	○	△	160	—	—	—	
	5012-6	○	△	145	—	—	—	
	5012-8	○	△	170	—	—	—	
	5016-4	○	△	129	—	—	—	
	5016-6	○	△	175	—	—	—	
	6310-8	△	△	—	—	—	—	
	6312-6	△	△	—	—	—	—	
	6312-8	△	△	—	—	—	—	
	DK	1404-4	△	×	—	—	—	—
		1404-6	△	×	—	—	—	—
		1605-3	○	△	45	—	—	—
1605-4		○	△	50	—	—	—	
2004-3		○	×	42	—	—	—	
2004-4		○	×	46	—	—	—	
2005-3		○	△	46	—	—	—	
2005-4		○	△	51	—	—	—	
2006-3		△	△	—	—	—	—	
2006-4		△	△	—	—	—	—	
2008-4		△	△	—	—	—	—	
2504-3		○	△	43	—	—	—	
2504-4		○	△	47	—	—	—	
2505-3		○	△	46	—	—	—	
2505-4		○	△	51	—	—	—	
2506-3		○	△	52	—	—	—	
2506-4		○	△	60	—	—	—	
2508-3		○	△	62	—	—	—	
2508-4		○	△	71	—	—	—	
2510-3		○	△	80	—	—	—	
2510-4		○	△	85	—	—	—	
2805-3		○	△	49	—	—	—	
2805-4		○	△	54	—	—	—	
2806-3		○	△	53	—	—	—	
2806-4		○	△	61	—	—	—	
2810-4		○	△	84	—	—	—	
3204-3		○	△	44	—	—	—	
3204-4		○	△	48	—	—	—	
3205-3		○	△	47	—	—	—	
3205-4		○	△	52	—	—	—	
3205-6		○	△	62	—	—	—	
3206-3		○	△	53	—	—	—	
3206-4	○	△	61	—	—	—		

○: available △: available per request ×: not available

*Please contact THK for more information regarding the model numbers which do not support WW and QZ.

Options

Dimensions of Each Model with an Option Attached

Unit: mm

Unit: mm

Model No.		WW availability	QZ availability	Dimensions including WW		Length of protrusion with QZ attached		Outer diameter of protrusion with QZ attached		Dimensions including QZ and WW	
				L	QWL	QWD	AL				
DK	3210-3	○	△	80	—	—	—	—	—	—	—
	3210-4	○	△	90	—	—	—	—	—	—	—
	3212-4	○	△	98	—	—	—	—	—	—	—
	3610-3	○	△	82	—	—	—	—	—	—	—
	3610-4	○	△	93	—	—	—	—	—	—	—
	4010-3	○	○	83	44	61	171	—	—	—	—
	4010-4	○	○	93	44	61	181	—	—	—	—
	4012-3	○	○	90	44	61	178	—	—	—	—
	4012-4	○	○	103	44	61	191	—	—	—	—
	4016-4	○	○	120	44	61	208	—	—	—	—
	4020-3	○	○	123	47	61	217	—	—	—	—
	5010-3	○	△	83	—	—	—	—	—	—	—
	5010-4	○	△	93	—	—	—	—	—	—	—
	5010-6	○	△	114	—	—	—	—	—	—	—
	5012-3	○	△	97	—	—	—	—	—	—	—
	5012-4	○	△	110	—	—	—	—	—	—	—
	5016-3	○	△	111	—	—	—	—	—	—	—
	5016-4	○	△	129	—	—	—	—	—	—	—
	5020-3	○	△	136	—	—	—	—	—	—	—
	6310-4	△	△	—	—	—	—	—	—	—	—
6310-6	△	△	—	—	—	—	—	—	—	—	
6312-3	△	△	—	—	—	—	—	—	—	—	
6312-4	△	△	—	—	—	—	—	—	—	—	
6320-3	△	△	—	—	—	—	—	—	—	—	
DKN	4020-3	○	○	223	47	61	317	—	—	—	—
	5020-3	○	△	243	—	—	—	—	—	—	—
	6320-3	△	△	—	—	—	—	—	—	—	—
BLW	1510-5.6	○	○	96	25.5	31	140	—	—	—	—
	1616-3.6	△	○	—	25.5	31	(135.5)	—	—	—	—
	2020-3.6	○	△	112	—	—	—	—	—	—	—
	2525-3.6	○	△	131.5	—	—	—	—	—	—	—
	3232-3.6	○	○	162.6	37.5	53	230	—	—	—	—
	3636-3.6	○	△	191	—	—	—	—	—	—	—
	4040-3.6	○	△	201.8	—	—	—	—	—	—	—
5050-3.6	○	△	255.8	—	—	—	—	—	—	—	
WHF (Precision)	1530-3.4	×	○	—	25.5	31	115.5	—	—	—	—
	1540-3.4	×	○	—	25.5	31	132.6	—	—	—	—
	2020-3.4	×	△	—	—	—	—	—	—	—	—
	2025-3.4	×	△	—	—	—	—	—	—	—	—
	2030-3.4	×	△	—	—	—	—	—	—	—	—
	2040-3.4	×	△	—	—	—	—	—	—	—	—
	2525-3.4	×	△	—	—	—	—	—	—	—	—
2550-3.4	×	△	—	—	—	—	—	—	—	—	
BLK (Precision)	1510-5.6	○	○	51	25.5	31	95	—	—	—	—
	1616-2.8	△	○	—	29	31	(112)	—	—	—	—
	1616-3.6	△	○	—	29	31	(96)	—	—	—	—
	2020-2.8	○	△	72	—	—	—	—	—	—	—
2020-3.6	○	△	52	—	—	—	—	—	—	—	

○: available △: available per request ×: not available

() indicates the dimensions with QZ but without WW.

*Please contact THK for more information regarding the model numbers which do not support WW and QZ.

Model No.		WW availability	QZ availability	Dimensions including WW		Length of protrusion with QZ attached		Outer diameter of protrusion with QZ attached		Dimensions including QZ and WW	
				L	QWL	QWD	AL				
BLK (Precision)	2525-2.8	○	△	87	—	—	—	—	—	—	—
	2525-3.6	○	△	62	—	—	—	—	—	—	—
	3232-2.8	○	○	109.6	37.5	53	177	—	—	—	—
	3232-3.6	○	○	77.6	37.5	53	145	—	—	—	—
	3620-5.6	○	△	88	—	—	—	—	—	—	—
	3624-5.6	△	△	—	—	—	—	—	—	—	—
	3636-2.8	○	△	123	—	—	—	—	—	—	—
	3636-3.6	○	△	87	—	—	—	—	—	—	—
	4040-2.8	○	△	135.8	—	—	—	—	—	—	—
	4040-3.6	○	△	95.8	—	—	—	—	—	—	—
	5050-2.8	○	△	166.8	—	—	—	—	—	—	—
	5050-3.6	○	△	116.8	—	—	—	—	—	—	—
	WGF	0812-3	×	×	—	—	—	—	—	—	—
1015-3		×	×	—	—	—	—	—	—	—	—
1320-3		×	×	—	—	—	—	—	—	—	—
1520-1.5		○	○	52	25.5	31	96	—	—	—	—
1520-3		○	○	52	25.5	31	96	—	—	—	—
1530-1		×	○	—	25.5	31	(84)	—	—	—	—
1530-3		×	○	—	25.5	31	(114)	—	—	—	—
1540-1.5		×	○	—	25.5	31	(93)	—	—	—	—
2040-1		×	△	—	—	—	—	—	—	—	—
2040-3		×	△	—	—	—	—	—	—	—	—
2060-1.5		×	△	—	—	—	—	—	—	—	—
2550-1		×	△	—	—	—	—	—	—	—	—
2550-3		×	△	—	—	—	—	—	—	—	—
3060-1		×	○	—	37.5	53	(137)	—	—	—	—
3060-3		×	○	—	37.5	53	(197)	—	—	—	—
3090-1.5		×	○	—	37.5	53	(167)	—	—	—	—
4080-1		×	△	—	—	—	—	—	—	—	—
4080-3		×	△	—	—	—	—	—	—	—	—
50100-1		×	△	—	—	—	—	—	—	—	—
50100-3		×	△	—	—	—	—	—	—	—	—
BNK	0401-3	×	×	—	—	—	—	—	—	—	—
	0501-3	×	×	—	—	—	—	—	—	—	—
	0601-3	×	×	—	—	—	—	—	—	—	—
	0801-3	×	×	—	—	—	—	—	—	—	—
	0802-3	×	×	—	—	—	—	—	—	—	—
	0810-3	×	×	—	—	—	—	—	—	—	—
	1002-3	×	×	—	—	—	—	—	—	—	—
	1004-2.5	×	×	—	—	—	—	—	—	—	—
	1010-1.5	×	×	—	—	—	—	—	—	—	—
	1205-2.5	×	×	—	—	—	—	—	—	—	—
	1402-3	×	×	—	—	—	—	—	—	—	—
	1404-3	△	×	—	—	—	—	—	—	—	—
	1408-2.5	△	△	—	—	—	—	—	—	—	—
1510-5.6	○	○	51	25.5	31	95	—	—	—	—	
1520-3	△	○	—	25.5	31	(96)	—	—	—	—	
1616-3.6	△	○	—	25.5	31	(93)	—	—	—	—	

Unit: mm

Model No.		WW availability	QZ availability	Dimensions including WW		Length of protrusion with QZ attached	Outer diameter of protrusion with QZ attached	Dimensions including QZ and WW
				L	QWL			
BNK	2010-2.5	○	△	54	—	—	—	—
	2020-3.6	○	△	59	—	—	—	—
	2520-3.6	△	△	—	—	—	—	—
BNT (both Precision and Rolled)	1404-3.6	△	×	—	—	—	—	—
	1405-2.6	△	×	35	—	—	—	—
	1605-2.6	△	△	36	29	31	94	—
	1808-3.6	△	△	—	—	—	—	—
	2005-2.6	△	△	35	—	—	—	—
	2010-2.6	△	△	58	—	—	—	—
	2505-2.6	△	△	35	—	—	—	—
	2510-5.3	△	△	94	—	—	—	—
	2806-2.6	△	△	42	—	—	—	—
	2806-5.3	△	△	67	—	—	—	—
	3210-2.6	△	△	64	—	—	—	—
	3210-5.3	△	△	94	—	—	—	—
	3610-2.6	△	△	64	—	—	—	—
	3610-5.3	△	△	96	—	—	—	—
	4512-5.3	△	△	115	—	—	—	—
WHF (Rolled)	1530-3.4	×	○	—	25.5	31	115.5	—
	2020-3.4	×	△	—	—	—	—	—
	2040-3.4	×	△	—	—	—	—	—
	2525-3.4	×	△	—	—	—	—	—
	2550-3.4	×	△	—	—	—	—	—
BLK (Rolled)	1510-5.6	○	○	51	25.5	31	95	—
	1616-3.6	△	○	—	25.5	31	(89)	—
	1616-7.2	△	○	—	25.5	31	(89)	—
	2020-3.6	○	△	52	—	—	—	—
	2020-7.2	○	△	52	—	—	—	—
	2525-3.6	○	△	62	—	—	—	—
	2525-7.2	○	△	62	—	—	—	—
	3232-3.6	○	○	77.6	37.5	53	145	—
	3232-7.2	○	○	77.6	37.5	53	145	—
	3620-5.6	○	△	88	—	—	—	—
	3624-5.6	○	△	104	—	—	—	—
	3636-3.6	△	△	—	—	—	—	—
	3636-7.2	△	△	—	—	—	—	—
	4040-3.6	△	△	—	—	—	—	—
	4040-7.2	△	△	—	—	—	—	—
5050-3.6	△	△	—	—	—	—	—	
5050-7.2	△	△	—	—	—	—	—	
WTF	1520-3	○	○	52	25.5	31	96	—
	1520-6	○	○	52	25.5	31	96	—
	1530-2	×	○	—	25.5	31	(84)	—
	1530-3	×	○	—	25.5	31	(114)	—
	2040-2	×	△	—	—	—	—	—
	2040-3	×	△	—	—	—	—	—
	2550-2	×	△	—	—	—	—	—
	2550-3	×	△	—	—	—	—	—

Unit: mm

Model No.		WW availability	QZ availability	Dimensions including WW		Length of protrusion with QZ attached	Outer diameter of protrusion with QZ attached	Dimensions including QZ and WW
				L	QWL			
WTF	3060-2	×	○	—	37.5	53	(137.5)	—
	3060-3	×	○	—	37.5	53	(197.5)	—
	4080-2	×	△	—	—	—	—	—
	4080-3	×	△	—	—	—	—	—
	50100-2	×	△	—	—	—	—	—
	50100-3	×	△	—	—	—	—	—
CNF	1530-6	×	○	—	25.5	31	(114)	—
	2040-6	×	△	—	—	—	—	—
	2550-6	×	△	—	—	—	—	—
MBF	3060-6	×	○	—	37.5	53	(197)	—
	0401-3.7	×	×	—	—	—	—	—
	0601-3.7	×	×	—	—	—	—	—
	0802-3.7	×	×	—	—	—	—	—
	1002-3.7	×	×	—	—	—	—	—
	1202-3.7	×	×	—	—	—	—	—
	1402-3.7	△	×	—	—	—	—	—
	1404-3.7	△	×	—	—	—	—	—
	1006-2.6	×	△	—	—	—	—	—
	1208-2.6	×	△	—	—	—	—	—
BTK-V	1404-3.6	△	△	—	—	—	—	—
	1405-2.6	○	△	40	—	—	—	—
	1605-2.6	○	△	40	—	—	—	—
	1808-3.6	△	△	—	—	—	—	—
	2005-2.6	○	△	40	—	—	—	—
	2010-2.6	○	△	61	—	—	—	—
	2505-2.6	○	△	40	—	—	—	—
	2510-5.3	○	○	98	32.5	45	163	—
	2806-2.6	○	△	47	—	—	—	—
	2806-5.3	○	△	65	—	—	—	—
	3210-2.6	○	○	68	32	57	132	—
	3210-5.3	○	○	98	32	57	162	—
	3610-2.6	○	○	70	31	64	132	—
	3610-5.3	○	○	100	31	64	162	—
	4010-5.3	○	○	100	34	66	168	—
	4512-5.3	△	△	—	—	—	—	—
	5016-5.3	○	○	145	35	79	215	—
	JPF	1404-4	△	×	—	—	—	—
1405-4		△	×	—	—	—	—	—
1605-4		○	×	60	—	—	—	—
2005-6		○	×	80	—	—	—	—
2505-6		○	×	80	—	—	—	—
2510-4		○	×	112	—	—	—	—
2805-6		○	×	80	—	—	—	—
2806-6		○	×	90	—	—	—	—
3210-6		○	×	135	—	—	—	—
3610-6		○	×	138	—	—	—	—
4010-6	○	×	138	—	—	—	—	

○: available △: available per request ×: not available

() indicates the dimensions with QZ but without WW.

*Please contact THK for more information regarding the model numbers which do not support WW and QZ.

Model number coding

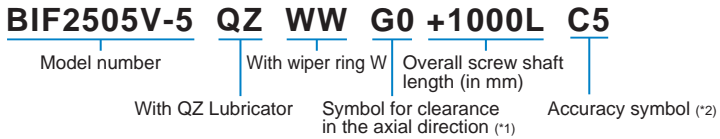
(*1) See **A15-19**. (*2) See **A15-12**.

Note) QZ Lubricator and wiper ring W are not sold alone.

Specifications of the Bellows

Bellows are available as a contamination protection accessory. Use this specification sheet.

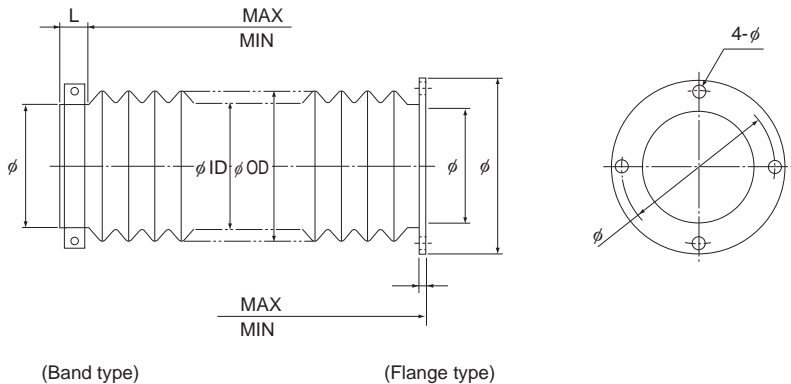

Specifications of the Bellows

Supported Ball Screw models:

Dimensions of the Bellows

Stroke: () mm MAX:() mm MIN:() mm

Permissible outer diameter:(ϕ OD) Desired inner diameter:(ϕ ID)

How It Is Used

Installation direction:(horizontal, vertical, slant) Speed:() mm/sec. mm/min.

Motion:(reciprocation, vibration)

Conditions

Resistance to oil and water:(necessary, unnecessary) Oil name ()

Chemical resistance: Name () \times () %

Location:(indoor, outdoor)

Remarks:

Number of Units To Be Manufactured:

Model Number Coding

The model number configuration for ball screws differs depending on the type. Table 1 Refer to the corresponding configuration example shown in Table 3.

THK can also provide shaft end shapes matched to support units. These can also be denoted in the symbols, which should be used for this purpose.

[Precision ball screw types and sample model number configurations]

Table 1

	Model No.		Shaft end shape	Model number coding
Precision	SBN-V, SBK, SDA-V, HBN, SBKH, BIF-V, BNFN-V/BNFN, MDK, MBF, BNF-V/BNF, DIK, DKN, BLW, DK, MDK, WHF, BLK, WGF, BNT		Fixed Side : H, J Supported Side : K	[1]
	Unfinished Shaft Ends A	MBF, MDK, BNF, BIF		[2]
	Unfinished Shaft Ends B	BNF, BIF	Y	[3]
	Finished Shaft Ends	BNK		[4]
	Rotary Ball Screw	BLR, DIR	Fixed Side : H, J Supported Side : K	[5]
Ball Screw/Spline	BNS-A, BNS, NS-A, NS	—	[6]	

[Rolled ball screw types and sample model number configurations]

Table 2

	Model No.		Shaft end shape	Model number coding
Rolled	Unfinished Shaft Ends	MTF	Fixed Side : H, J Supported Side : K	[6]
	Ball screw nut and screw shaft combination products	JPF, BTK-V, MTF, WHF, BLK, WTF, CNF, BNT		[7]
	Rotary Ball Screw	BLR		[8]
	Standalone screw shafts	TS		[9]
	Standalone ball screw nuts	BTK-V, BLK, WTF, CNF, BNT, BLR	—	[10]

[Support unit, nut bracket and lock nut types and sample model number configurations]

Table 3

Model No.		Shaft end shape	Model number coding
Support Unit	EK, BK, FK, EF, BF, FF	—	[10]
Nut brackets for BNK	MC	—	
Lock Nut	RN	—	

[1 Precision Ball Screw]

- Models SBN-V, SBK, SDA-V, HBN, SBKH, BIF-V, BNFN-V/BNFN, MDK, MBF, BNF-V/BNF, DIK, DKN, BLW, DK, MDK, WHF, BLK, WGF and BNT

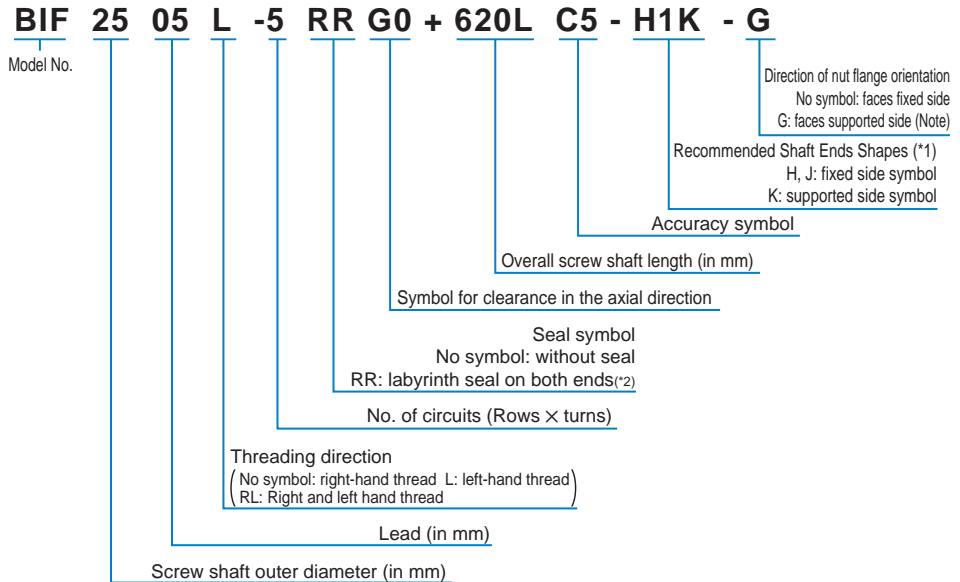

(*1) See [A15-324](#) to [A15-329](#).

(*2) See [A15-336](#).

Note) The ball nut flange faces the fixed side unless otherwise specified.

If desiring the flange to face the supported side, add symbol G in the end of the Ball Screw model number when placing an order.

[2 Precision Ball Screw Unfinished Shaft Ends]

- Models BIF, MDK, MBF and BNF

BIF2505-5RRG0+720LC5A

Unfinished shaft ends code (A or B)

Refer to [A15-110](#) for the corresponding model number.

[3 Precision Ball Screw Finished Shaft Ends]

- Model BNK

BNK2020-5+620LC5Y

Finished shaft ends code

Refer to **A15-136** for the corresponding model number.

[4 Rotary Ball Screw]

- Models BLR and DIR

BLR2020-3.6 K UU G1 +1000L C5

Model No.

Flange orientation
symbol

Symbol for clearance
in the axial direction

Symbol for
support bearing seal

Symbol for clearance
in the axial direction

Overall screw shaft
length (in mm)

Accuracy symbol

[5 Ball Screw/Spline]

- Models BNS-A, BNS, NS-A and NS

BNS2525 +600L

Model No.

Overall shaft length (in mm)

[6 Rolled Ball Screw Unfinished Shaft Ends]

- Model MTF

MTF 08 02 +250L C7 T - H1

Model No.

Screw shaft
outer diameter
(in mm)

Overall shaft length
(in mm)

Lead
(in mm)

Recommended Shaft Ends Shapes
(See **A15-324**~onward)

Symbol for ball screw shaft
Accuracy symbol (No symbol for Normal Grade)

[7 Rolled Ball Screw]

● Models BTK-V, MTF, WHF, BLK, WTF, CNF and BNT(Rolled)

- Combination of the Ball Screw Nut and the Screw Shaft

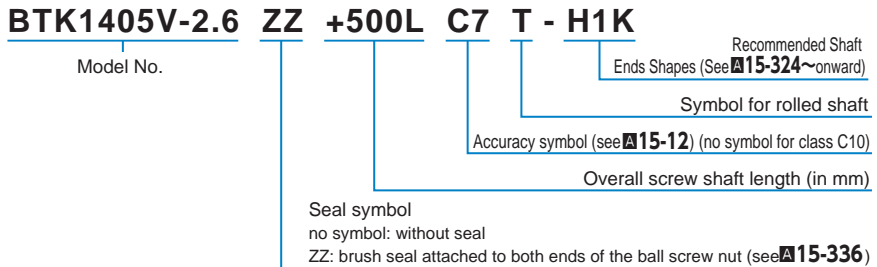

[8 Rolled Ball Screw]

● Model JPF

- Rolled Ball Screw model JPF

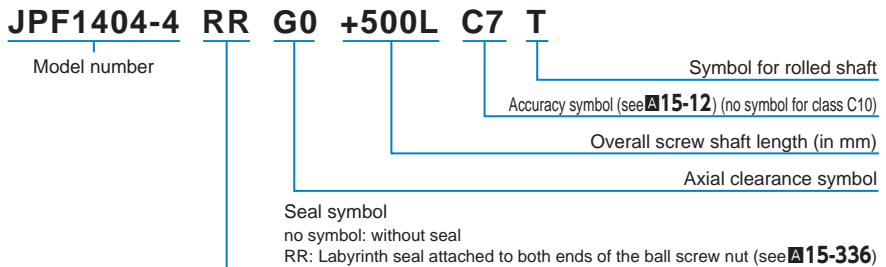

[9 Rolled Rotary Ball Screw]

● Model BLR (Rolled)

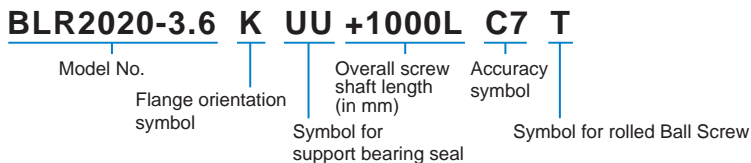

Note) For clearance in the axial direction, see [A15-19](#).

[10 Standalone rolled shafts/nuts]

- Models BTK-V, BLK/WTF, CNF, BNT(Rolled), BLR(Rolled) and TS

Rolled shaft only

TS 14 05 +500L C7

Lead (in mm)

Screw shaft outer diameter (in mm)

Accuracy symbol (see page [A15-12](#)) (no symbol for class C10)

Overall screw shaft length (in mm)

Nut only

BTK1405V-2.6 ZZ

Model No.

Seal symbol
no symbol: without seal
ZZ: brush seal attached to both ends of the ball screw nut (see [A15-336](#))

Symbol for rolled ball screw shaft

[11 Support units, nut brackets and lock nuts]

- Models EK, BK, FK, EF, BF, FF, MC and RN

EK12

Model No.

[12 Ball screw options, W wiper rings and QZ lubricators]

BIF2505V-5 QZ WW G0 +1000L C5

With QZ Lubricator

With wiper ring W

(*) See [A15-344](#).

Notes on Ordering

[Options]

The details of the product options differ according to the model number. Check before ordering. See [A15-335](#).

[Other notes on specifications]

Contact THK separately for information on the specifications below.

- Shaft end shape (for recommended shaft end shapes, indicate the symbol).
- Surface Treatment (see [B0-20](#))
- Grease used
- Nipple mounting

[Handling]

- (1) Please use at least two people to move any product weighing 20 kg or more, or use a dolly or another conveyance. Doing so may cause injury or damage.
- (2) Do not disassemble the parts. This will result in loss of functionality.
- (3) Tilting the Ball Screw shaft and the Ball Screw nut may cause them to fall by their own weight.
- (4) Take care not to drop or strike the Ball Screw. Failure to do so could cause injury or product damage. Giving an impact to it could also cause damage to its function even if the product looks intact.
- (5) When assembling, do not remove the Ball Screw nut from the Ball Screw shaft.
- (6) When handling the product, wear protective gloves, safety shoes, etc., as necessary to ensure safety.

[Precautions on Use]

- (1) Prevent foreign material, such as cutting chips or coolant, from entering the product. Failure to do so may cause damage.
- (2) If the product is used in an environment where cutting chips, coolant, corrosive solvents, water, etc., may enter the product, use bellows, covers, etc., to prevent them from entering the product.
- (3) Do not use the product at temperature of 80°C or higher. Except for the heat-resistant models, exposure to higher temperatures may cause the resin/rubber parts to deform/be damaged.
- (4) If foreign material such as cutting chips adheres to the product, replenish the lubricant after cleaning the product.
- (5) Micro-oscillation makes it difficult for oil film to form on the raceway in contact with the rolling element, and may lead to fretting. Accordingly, use grease offering excellent fretting toughness. It is also recommended that the Ball Screw nut be turned once or so on a regular basis to make sure oil film is formed between the raceway and rolling element.
- (6) Do not use undue force when fitting parts (pin, key, etc.) to the product. This may generate pressure marks on the raceway, leading to loss of functionality.
- (7) If an offset or skewing occurs with the Ball Screw shaft support and the Ball Screw nut, it may substantially shorten the service life. Pay much attention to components to be mounted and to the mounting accuracy.
- (8) If any of the rolling elements falls from the Ball Screw nut, contact THK instead of using the product.
- (9) When using this product with a vertical orientation, take preventive measures such as adding a safety mechanism to prevent falls. The own weight of the Ball Screw nut may cause it to fall.
- (10) Do not use this product beyond its permissible rotational speed. Doing so may cause accidents or component damage. Be sure to use the product within the specification range designated by THK.
- (11) Do not cause the Ball Screw nut to overshoot. The ball may drop, circulating parts may be damaged, raceway in contact with the ball may develop pressure marks, etc., resulting in malfunction. Continuing to use the product in this condition may lead to premature wear or damage to circulating parts.
- (12) Use the Ball Screw by providing a LM Guide, Ball Spline or other guide element. Otherwise, the Ball Screw may be damaged.
- (13) Insufficient rigidity or accuracy of mounting members causes the bearing load to concentrate on one point and the bearing performance will drop significantly. Accordingly, give sufficient consideration to the rigidity/accuracy of the housing and base and strength of the fixing bolts.

[Lubrication]

- (1) Thoroughly wipe off anti-rust oil and feed lubricant before using the product.
- (2) Do not mix different lubricants. Mixing greases using the same type of thickening agent may still cause adverse interaction between the two greases if they use different additives, etc.
- (3) When using the product in locations exposed to constant vibrations or in special environments such as clean rooms, vacuum and low/high temperature, use the grease appropriate for the specification/environment.
- (4) When lubricating the product having no grease nipple or oil hole, apply grease directly on the raceway and stroke the product several times to let the grease spread inside.
- (5) The consistency of grease changes according to the temperature. Take note that the torque of the Ball Screw also changes as the consistency of grease changes.
- (6) After lubrication, the rotational torque of the Ball Screw may increase due to the agitation resistance of grease. Be sure to perform a break-in to let the grease spread fully, before operating the machine.
- (7) Excess grease may scatter immediately after lubrication, so wipe off scattered grease as necessary.
- (8) The properties of grease deteriorate and its lubrication performance drops over time, so grease must be checked and added properly according to the use frequency of the machine.
- (9) Although the lubrication interval may vary according to operating conditions and the service environment, lubrication should be performed approximately every 100 km in travel distance (three to six months). Set the final lubrication interval/amount based on the actual machine.
- (10) Depending on the mounting orientation and access position, lubricant may not spread fully and poor lubrication may occur. Give full consideration to these factors in the design stage.
- (11) When using a Ball Screw, it is necessary to provide effective lubrication. Using the product without lubrication may increase wear of the rolling elements or shorten the service life.
Table1 (B15-106) shows a guideline for the feed amount of oil.

[Storage]

When storing the Ball Screw, enclose it in a package designated by THK and store it in a room in a horizontal orientation while avoiding high temperature, low temperature and high humidity. After the product has been in storage for an extended period of time, lubricant inside may have deteriorated, so add new lubricant before use.

[Disposal]

Dispose of the product properly as industrial waste.

Precautions on Using Options for the Ball Screw

QZ Lubricator for the Ball Screw

For details regarding the QZ, see **A15-342**.

[Precaution on Selection]

Make sure the stroke length exceeds the total length of the screw shaft with the QZ Lubricator attached.

[Handling]

Take care not to drop or strike the product, which could result in injury or damage.

Keep air holes clear of grease or other obstructions.

The QZ Lubricator lubricates the raceway only, so it must be used in combination with regular greasing or lubrication.

In models equipped with the QZ Lubricator, raceways are provided with the minimum required level of lubrication. Please note: Use of the product in a vertical position, or other usage conditions, may cause lubricant to drip from the ball screw shaft.

[Service environment]

Be sure the service temperature of this product is between -10 to 50°C , and do not clean the product by immersing it in an organic solvent or white kerosene, or leave it unpacked.



Ball Screw

THK General Catalog

Ball Screw

THK General Catalog

B Support Book

Features and Types	B 15-6	Examples of Selecting a Ball Screw	B 15-69
Features of the Ball Screw	B 15-6	• High-speed Transfer Equipment (Horizontal Use) ..	B 15-69
• Driving Torque One Third of the Sliding Screw ..	B 15-6	• Vertical Conveyance System	B 15-83
• Examples of Calculating Driving Torque	B 15-8	Options	B 15-95
• Ensuring High Accuracy	B 15-9	Contaminator Protection	B 15-96
• Capable of Micro Feeding	B 15-10	Lubrication	B 15-97
• High Rigidity without Backlash	B 15-11	Corrosion Resistance (Surface Treatment, etc.) ..	B 15-97
• Capable of Fast Feed	B 15-12	Contamination Protection Seal for Ball Screws ..	B 15-98
Types of Ball Screws	B 15-14	Wiper Ring W	B 15-99
Point of Selection	B 15-16	Dust Cover for Ball Screws	B 15-101
Flowchart for Selecting a Ball Screw	B 15-16	QZ Lubricator	B 15-102
Accuracy of the Ball Screw	B 15-19	Mounting Procedure and Maintenance ..	B 15-104
• Lead Angle Accuracy	B 15-19	Mounting Procedure	B 15-104
• Accuracy of the Mounting Surface	B 15-22	• Installing the Support Unit	B 15-104
• Axial Clearance	B 15-27	• Installation onto the Table and the Base ..	B 15-104
• Preload	B 15-28	• Checking the Accuracy and Fully Fastening the Support Unit ..	B 15-105
• Example of calculating the preload torque	B 15-31	• Connection with the Motor	B 15-105
Selecting a Screw Shaft	B 15-32	Maintenance Method	B 15-106
• Maximum Length of the Screw Shaft	B 15-32	• Amount of Lubricant	B 15-106
• Standard Combinations of Shaft Diameter and Lead for the Precision Ball Screw ..	B 15-34	Model No.	B 15-107
• Standard Combinations of Shaft Diameter and Lead for the Rolled Ball Screw ..	B 15-35	• Model Number Coding	B 15-107
Method for Mounting the Ball Screw Shaft ..	B 15-36	• Notes on Ordering	B 15-111
Permissible Axial Load	B 15-38	Precautions on Use	B 15-112
Permissible Rotational Speed	B 15-40	Precautions on Using Options for the Ball Screw ..	B 15-114
Selecting a Nut	B 15-43	• QZ Lubricator for the Ball Screw	B 15-114
• Types of Nuts	B 15-43		
Selecting a Model Number	B 15-46		
• Calculating the Axial Load	B 15-46		
• Static Safety Factor	B 15-47		
• Studying the Service Life	B 15-48		
Studying the Rigidity	B 15-51		
• Axial Rigidity of the Feed Screw System ..	B 15-51		
Studying the Positioning Accuracy	B 15-55		
• Causes of Error in the Positioning Accuracy ..	B 15-55		
• Studying the Lead Angle Accuracy	B 15-55		
• Studying the Axial Clearance	B 15-55		
• Studying the Axial Clearance of the Feed Screw System ..	B 15-57		
• Example of considering the rigidity of a feed screw system ..	B 15-57		
• Studying the Thermal Displacement through Heat Generation ..	B 15-59		
• Studying the Orientation Change during Traveling ..	B 15-60		
Studying the Rotational Torque	B 15-61		
• Frictional Torque Due to an External Load ..	B 15-61		
• Torque Due to a Preload on the Ball Screw ..	B 15-62		
• Torque Required for Acceleration	B 15-63		
• Investigating the Terminal Strength of Ball Screw Shafts ..	B 15-64		
Studying the Driving Motor	B 15-66		
• When Using a Servomotor	B 15-66		
• When Using a Stepping Motor (Pulse Motor) ..	B 15-68		

A Product Descriptions (Separate)

Types of Ball Screws	A15-6
Point of Selection	A15-8
Flowchart for Selecting a Ball Screw	A15-8
Accuracy of the Ball Screw	A15-11
• Lead Angle Accuracy	A15-11
• Accuracy of the Mounting Surface	A15-14
• Axial Clearance	A15-19
• Preload	A15-20
Selecting a Screw Shaft	A15-24
• Maximum Length of the Screw Shaft	A15-24
• Standard Combinations of Shaft Diameter and Lead for the Precision Ball Screw	A15-26
• Standard Combinations of Shaft Diameter and Lead for the Rolled Ball Screw	A15-27
Method for Mounting the Ball Screw Shaft	A15-28
Permissible Axial Load	A15-30
Permissible Rotational Speed	A15-32
Selecting a Nut	A15-35
• Types of Nuts	A15-35
Selecting a Model Number	A15-40
• Calculating the Axial Load	A15-40
• Static Safety Factor	A15-41
• Studying the Service Life	A15-42
Studying the Rigidity	A15-45
• Axial Rigidity of the Feed Screw System	A15-45
Studying the Positioning Accuracy	A15-49
• Causes of Error in the Positioning Accuracy	A15-49
• Studying the Lead Angle Accuracy	A15-49
• Studying the Axial Clearance	A15-49
• Studying the Axial Clearance of the Feed Screw System	A15-51
• Studying the Thermal Displacement through Heat Generation	A15-53
• Studying the Orientation Change during Traveling	A15-54
Studying the Rotational Torque	A15-55
• Frictional Torque Due to an External Load	A15-55
• Torque Due to a Preload on the Ball Screw	A15-56
• Torque Required for Acceleration	A15-57
• Investigating the Terminal Strength of Ball Screw Shafts	A15-58
Studying the Driving Motor	A15-60
• When Using a Servomotor	A15-60
• When Using a Stepping Motor (Pulse Motor)	A15-62
Features of Each Model	A15-63
Precision, Caged Ball Screw	
Models SBN-V, SBK, SDA-V, HBN and SBKH	A15-64
• Structure and Features	A15-65
• Ball Cage Effect	A15-65
• Types and Features	A15-68
• Examples of Assembling Models HBN and SBKH	A15-70

Dimensional Drawing, Dimensional Table

Model SBN-V	A15-72
Model SBK	A15-76
Model SDA-V	A15-80
Model HBN	A15-86
Model SBKH	A15-88

Models EBA, EBB, EBC, EPA, EPB and EPC

• Structure and Features	A15-91
• Types and Features	A15-92
• Accuracy Standards	A15-93

Dimensional Drawing, Dimensional Table

Model EBA (Oversized-ball preload type or non-preloaded type)	A15-94
Model EBB (Oversized-ball preload type or non-preloaded type)	A15-96
Model EBC (Oversized-ball preload type or non-preloaded type)	A15-98
Model EPA (Offset Preload Type)	A15-100
Model EPB (Offset Preload Type)	A15-102
Model EPC (Offset Preload Type)	A15-104

Unfinished Shaft Ends Precision Ball Screw

Models BIF, MDK, MBF and BNF	A15-106
• Structure and Features	A15-107
• Types and Features	A15-108
• Nut Types and Axial Clearance	A15-109

Dimensional Drawing, Dimensional Table

Unfinished Shaft Ends	A15-110
-----------------------------	---------

Finished Shaft Ends Precision Ball Screw

Model BNK	A15-132
• Features	A15-133
• Types and Features	A15-133
• Table of Ball Screw Types with Finished Shaft Ends and the Corresponding Support Units and Nut Brackets	A15-134

Dimensional Drawing, Dimensional Table

BNK0401-3 Shaft diameter: 4; lead: 1	A15-136
BNK0501-3 Shaft diameter: 5; lead: 1	A15-138
BNK0601-3 Shaft diameter: 6; lead: 1	A15-140
BNK0801-3 Shaft diameter: 8; lead: 1	A15-142
BNK0802-3 Shaft diameter: 8; lead: 2	A15-144
BNK0810-3 Shaft diameter: 8; lead: 10	A15-146
BNK1002-3 Shaft diameter: 10; lead: 2	A15-148
BNK1004-2.5 Shaft diameter: 10; lead: 4	A15-150
BNK1010-1.5 Shaft diameter: 10; lead: 10	A15-152
BNK1202-3 Shaft diameter: 12; lead: 2	A15-154
BNK1205-2.5 Shaft diameter: 12; lead: 5	A15-156
BNK1208-2.6 Shaft diameter: 12; lead: 8	A15-158

BNK1402-3 Shaft diameter: 14; lead: 2 ..	A 15-160
BNK1404-3 Shaft diameter: 14; lead: 4 ..	A 15-162
BNK1408-2.5 Shaft diameter: 14; lead: 8 ..	A 15-164
BNK1510-5.6 Shaft diameter: 15; lead: 10 ..	A 15-166
BNK1520-3 Shaft diameter: 15; lead: 20 ..	A 15-168
BNK1616-3.6 Shaft diameter: 16; lead: 16 ..	A 15-170
BNK2010-2.5 Shaft diameter: 20; lead: 10 ..	A 15-172
BNK2020-3.6 Shaft diameter: 20; lead: 20 ..	A 15-174
BNK2520-3.6 Shaft diameter: 25; lead: 20 ..	A 15-176

Precision Ball Screw

Models BIF-V, DIK, BNFN-V/BNFN, DKN, BLW, BNF-V/BNF, DK, MDK, WHF, BLK/WGF and BNT ..	A 15-178
• Structure and Features	A 15-179
• Types and Features	A 15-180

Dimensional Drawing, Dimensional Table

Preload Type of Precision Ball Screw....	A 15-184
No Preload Type of Precision Ball Screw ..	A 15-204
No Preload Type of Precision Ball Screw (Square Nut) ..	A 15-228
• Model Number Coding	A 15-230

Precision Rotary Ball Screw

Models DIR and BLR	A 15-232
• Structure and Features	A 15-233
• Type	A 15-235
• Accuracy Standards	A 15-236
• Example of Assembly	A 15-238

Dimensional Drawing, Dimensional Table

Model DIR Standard Lead Rotary-Nut Ball Screw ..	A 15-240
Model BLR Large Lead Rotary-Nut Ball Screw ..	A 15-242
• Permissible Rotational Speeds for Rotary Ball Screws ..	A 15-244

Precision Ball Screw/Spline

Models BNS-A, BNS, NS-A and NS	A 15-246
• Structure and Features	A 15-247
• Type	A 15-248
• Accuracy Standards	A 15-249
• Action Patterns	A 15-250
• Example of Assembly	A 15-253
• Example of Use	A 15-254
• Precautions on Use	A 15-255

Dimensional Drawing, Dimensional Table

Model BNS-A Compact Type: Linear-Rotary Motion ...	A 15-256
Model BNS Heavy Load Type: Linear-Rotary Motion ...	A 15-258
Model NS-A Compact Type: Linear Motion	A 15-260
Model NS Heavy Load Type: Linear Motion ..	A 15-262

Rolled Ball Screw

Models JPF, BTK-V, MTF, WHF, BLK/WTF, CNF and BNT ..	A 15-264
• Structure and Features	A 15-265
• Types and Features	A 15-266

Dimensional Drawing, Dimensional Table

Preload Type of Rolled Ball Screw	A 15-270
No Preload Type of Rolled Ball Screw...	A 15-272
No Preload Type of Rolled Ball Screw (Square Nut) ..	A 15-280
• Model Number Coding	A 15-283

Standard Unfinished Shaft Ends Rolled Ball Screw

Model MTF	A 15-284
• Structure and Features	A 15-285
• Types and Features	A 15-285

Dimensional Drawing, Dimensional Table

Unfinished Shaft Ends Rolled Ball Screw Model MTF ..	A 15-286
--	----------

Rolled Rotary Ball Screw

Model BLR	A 15-288
• Structure and Features	A 15-289
• Type	A 15-289
• Accuracy Standards	A 15-290
• Example of Assembly	A 15-291

Dimensional Drawing, Dimensional Table

Model BLR Large Lead Rotary Nut Rolled Ball Screw ..	A 15-294
• Maximum Length of the Ball Screw Shaft ..	A 15-296

Ball Screw Peripherals

Support Unit

Models EK, BK, FK, EF, BF and FF	A 15-300
• Structure and Features	A 15-300
• Type	A 15-302
• Types of Support Units and Applicable Screw Shaft Outer Diameters ..	A 15-303
• Model Numbers of Bearings and Characteristic Values ..	A 15-304
• Example of Installation	A 15-305
• Mounting Procedure	A 15-306
• Types of Recommended Shapes of the Shaft Ends ..	A 15-308

Dimensional Drawing, Dimensional Table

Model EK Square Type Support Unit on the Fixed Side ..	A 15-310
Model BK Square Type Support Unit on the Fixed Side ..	A 15-312
Model FK Round Type Support Unit on the Fixed Side ..	A 15-314
Model EF Square Type Support Unit on the Supported Side ..	A 15-318
Model BF Square Type Support Unit on the Supported Side ..	A 15-320
Model FF Round Type Support Unit on the Supported Side ..	A 15-322

Recommended Shapes of Shaft Ends - Shape H (H1, H2 and H3) (For Support Unit Models FK and EK) ..	A15-324
Recommended Shapes of Shaft Ends - Shape J (J1, J2 and J3) (For Support Unit Model BK) ..	A15-326
Recommended Shapes of Shaft Ends - Shape K (For Support Unit Models FF, EF and BF)	A15-328
Nut Bracket (Model MC)	A15-330
• Structure and Features	A15-330
• Type	A15-330
Dimensional Drawing, Dimensional Table	
Nut Bracket	A15-331
Lock Nut (Model RN)	A15-332
• Structure and Features	A15-332
• Type	A15-332
Dimensional Drawing, Dimensional Table	
Lock Nut	A15-333
Options	A15-335
Contaminaton Protection	A15-336
Lubrication	A15-337
Corrosion Resistance (Surface Treatment, etc.) ..	A15-337
Contamination Protection Seal for Ball Screws ..	A15-338
Wiper Ring W	A15-339
Dust Cover for Ball Screws.....	A15-341
QZ Lubricator.....	A15-342
Dimensions of Each Model with an Option Attached ..	A15-344
• Dimensions of the Ball Screw Nut Attached with Wiper Ring W and QZ Lubricator ..	A15-344
• Specifications of the Bellows	A15-352
Model No.	A15-353
• Model Number Coding	A15-353
• Notes on Ordering.....	A15-357
Precautions on Use	A15-358
Precautions on Using Options for the Ball Screw ..	A15-360
• QZ Lubricator for the Ball Screw	A15-360

Features of the Ball Screw

Driving Torque One Third of the Sliding Screw

With the Ball Screw, balls roll between the screw shaft and the nut to achieve high efficiency. Its required driving torque is only one third of the conventional sliding screw. (See Fig.1 and Fig.2.) As a result, it is capable of not only converting rotational motion to straight motion, but also converting straight motion to rotational motion.

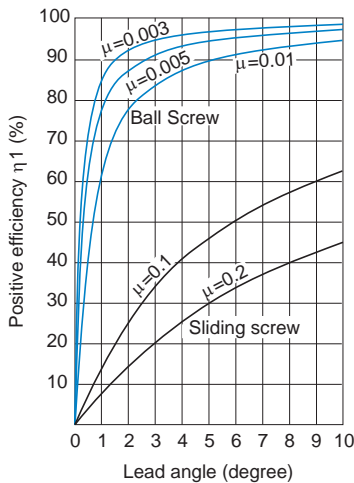

Fig.1 Positive Efficiency (Rotational to Linear)

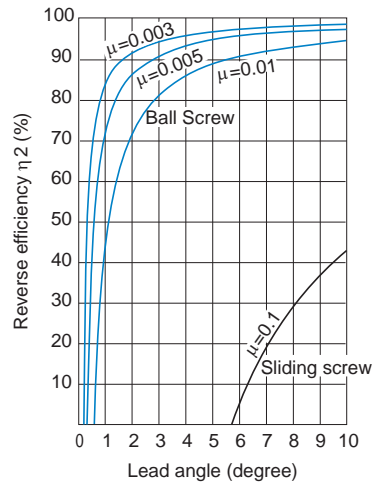

Fig.2 Reverse Efficiency (Linear to Rotational)

[Calculating the Lead Angle]

$$\tan\beta = \frac{Ph}{\pi \cdot d_p}$$

- β : Lead angle (°)
 d_p : Ball center-to-center diameter (mm)
 Ph : Feed screw lead (mm)

[Relationship between Thrust and Torque]

The torque or thrust generated when thrust or torque is applied is obtained from equations (1) to (3).

● **Driving Torque Required to Gain Thrust**

$$T = \frac{F_a \cdot Ph}{2\pi \cdot \eta_1} \dots\dots(1)$$

T : Driving torque (N-mm)

F_a : Frictional resistance on the guide surface (N)

F_a = μ × mg

μ : Frictional coefficient of the guide surface

g : Gravitational acceleration (9.8 m/s²)

m : Mass of the transferred object (kg)

Ph : Feed screw lead (mm)

η₁ : Positive efficiency of feed screw
(see Fig.1 on **B15-6**)

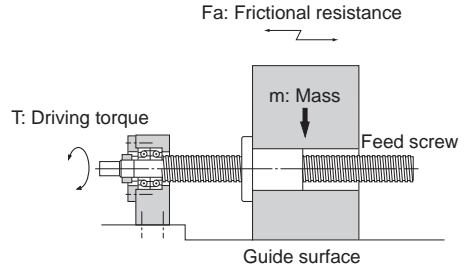

● **Thrust Generated When Torque is Applied**

$$F_a = \frac{2\pi \cdot \eta_1 \cdot T}{Ph} \dots\dots(2)$$

F_a : Thrust generated (N)

T : Driving torque (N-mm)

Ph : Feed screw lead (mm)

η₁ : Positive efficiency of feed screw
(see Fig.1 on **B15-6**)

● **Torque Generated When Thrust is Applied**

$$T = \frac{Ph \cdot \eta_2 \cdot F_a}{2\pi} \dots\dots(3)$$

T : Torque generated (N-m)

F_a : Thrust generated (N)

Ph : Feed screw lead (mm)

η₂ : Reverse efficiency of feed screw
(see Fig.2 on **B15-6**)

Examples of Calculating Driving Torque

When moving an object with a mass of 500 kg using a screw with an effective diameter of 33 mm and a lead length of 10 mm (lead angle: $5^{\circ}30'$), the required torque is obtained as follows.

Rolling guide ($\mu=0.003$)
Ball Screw (from $\mu=0.003$, $\eta=0.96$)

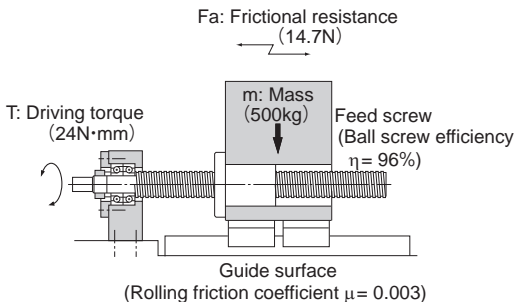

Frictional resistance on the guide surface

$$F_a = 0.003 \times 500 \times 9.8 = 14.7 \text{ N}$$

Driving torque

$$T = \frac{14.7 \times 10}{2\pi \times 0.96} = 24 \text{ N} \cdot \text{mm}$$

Rolling guide ($\mu=0.003$)
Ball Screw (from $\mu=0.2$, $\eta=0.32$)

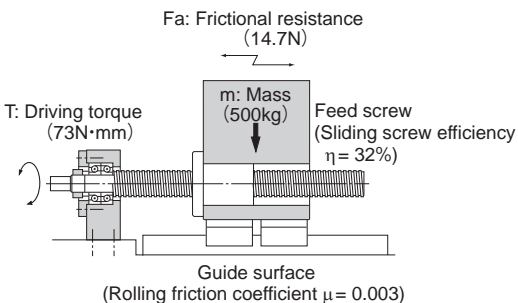

Frictional resistance on the guide surface

$$F_a = 0.003 \times 500 \times 9.8 = 14.7 \text{ N}$$

Driving torque

$$T = \frac{14.7 \times 10}{2\pi \times 0.32} = 73 \text{ N} \cdot \text{mm}$$

Ensuring High Accuracy

The Ball Screw is ground with the highest-level facilities and equipment at a strictly temperature-controlled factory, Its accuracy is assured under a thorough quality control system that covers assembly to inspection.



Automatic lead-measuring machine using laser

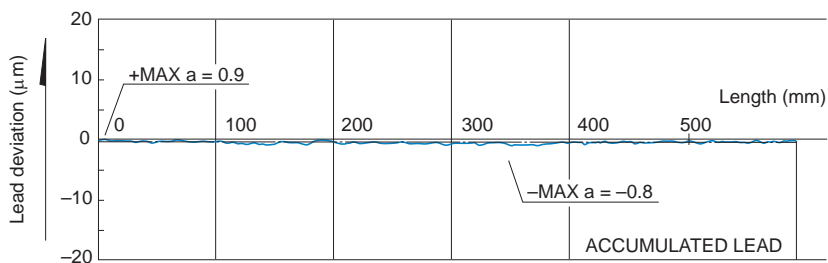

Fig.3 Lead Accuracy Measurement

[Conditions]

Model No.: BIF3205-10RRG0+903LC2

Table1 Lead Accuracy Measurement Unit: mm

Item	Standard value	Actual measurement
Directional target point	0	—
Representative travel distance error	± 0.011	-0.0012
Fluctuation	0.008	0.0017

Capable of Micro Feeding

The Ball Screw requires a minimal starting torque due to its rolling motion, and does not cause a slip, which is inevitable with a sliding motion. Therefore, it is capable of an accurate micro feeding. Fig.4 shows a travel distance of the Ball Screw in one-pulse, 0.1- μm feeding. (LM Guide is used for the guide surface.)

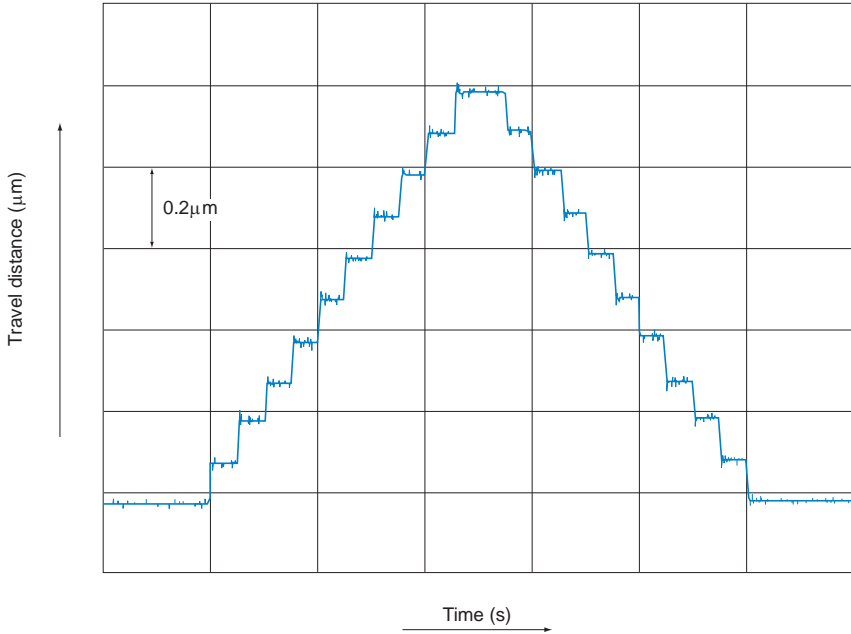

Fig.4 Data on Travel in 0.1- μm Feeding

High Rigidity without Backlash

Since the Ball Screw is capable of receiving a preload, the axial clearance can be reduced to below zero and the high rigidity is achieved because of the preload. In Fig.5, when an axial load is applied in the positive (+) direction, the table is displaced in the same (+) direction. When an axial load is provided in the reverse (-) direction, the table is displaced in the same (-) direction. Fig.6 shows the relationship between the axial load and the axial displacement. As indicated in Fig.6, as the direction of the axial load changes, the axial clearance occurs as a displacement. Additionally, when the Ball Screw is provided with a preload, it gains a higher rigidity and a smaller axial displacement than a zero clearance in the axial direction.

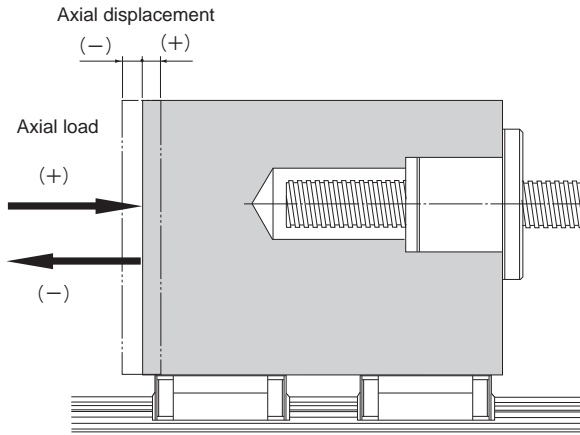

Fig.5

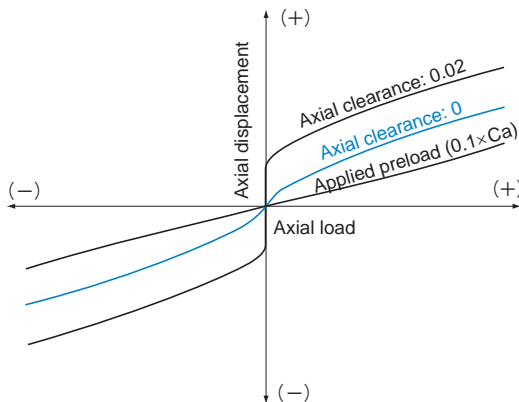

Fig.6 Axial Displacement in Relation to Axial Load

Capable of Fast Feed

Since the Ball Screw is highly efficient and generates little heat, it is capable of a fast feed.

[Example of High Speed]

Fig.7 shows a speed diagram for a large lead rolled Ball Screw operating at 2 m/s.

[Conditions]

Item	Description
Sample	Large Lead Rolled Ball Screw WTF3060 (Shaft diameter: 30mm; lead: 60mm)
Maximum speed	2m/s (Ball Screw rotational speed: 2,000 min ⁻¹)
Guide surface	LM Guide model SR25W

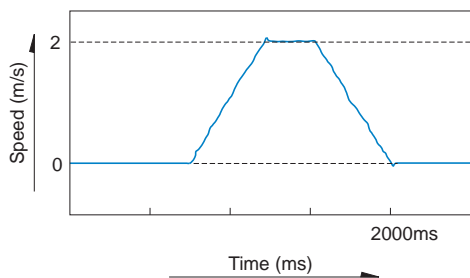
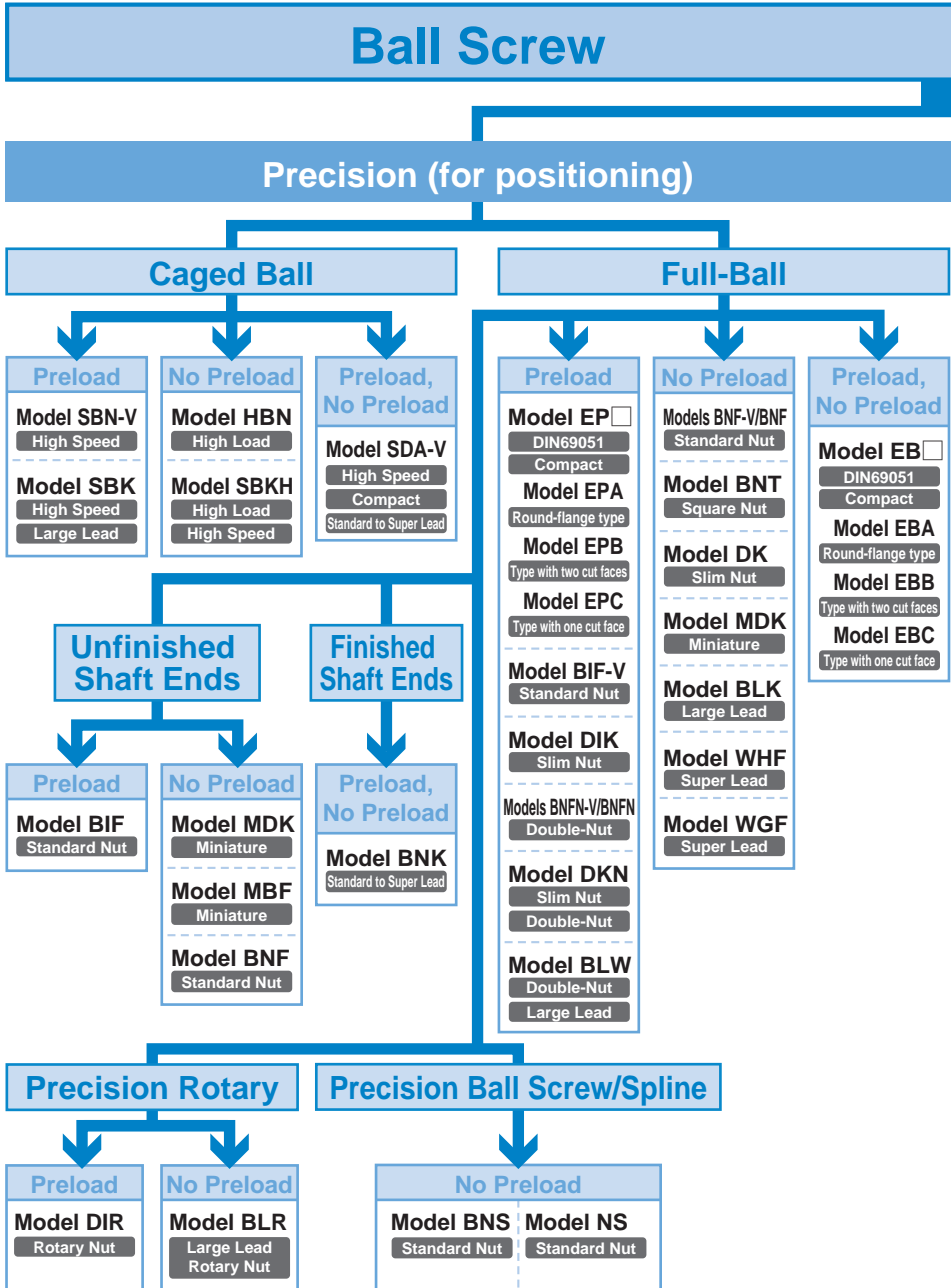

Fig.7 Velocity diagram

Features and Types

Features of the Ball Screw

Types of Ball Screws



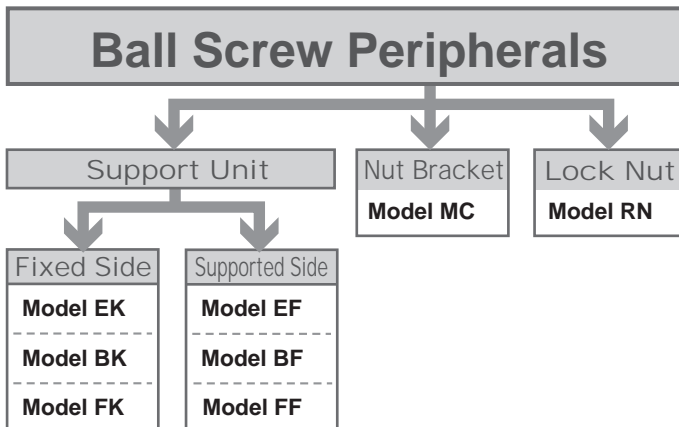
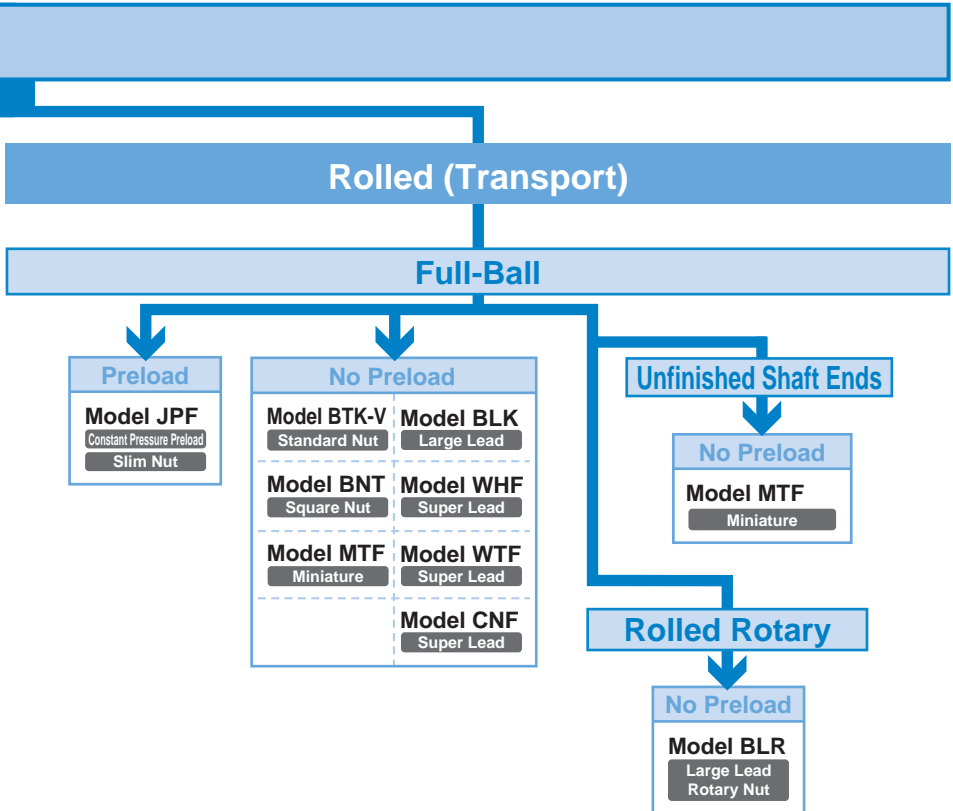

Flowchart for Selecting a Ball Screw

[Ball Screw Selection Procedure]

When selecting a Ball Screw, it is necessary to make a selection while considering various parameters. The following is a flowchart for selecting a Ball Screw.

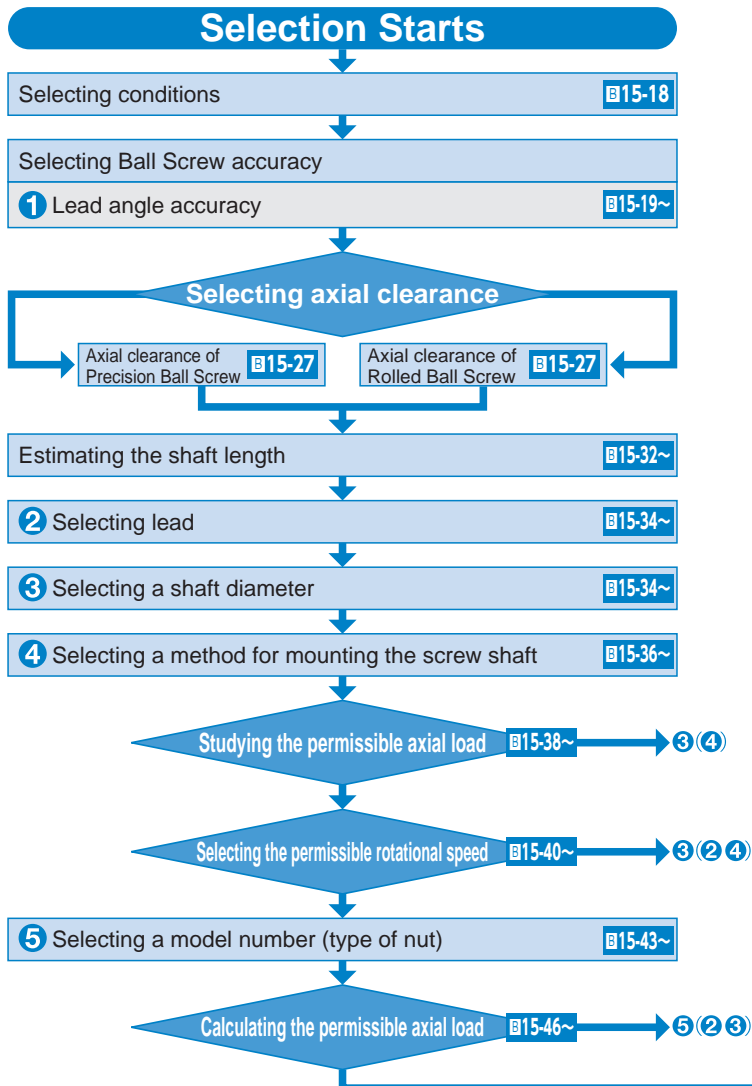

Point of Selection
Flowchart for Selecting a Ball Screw

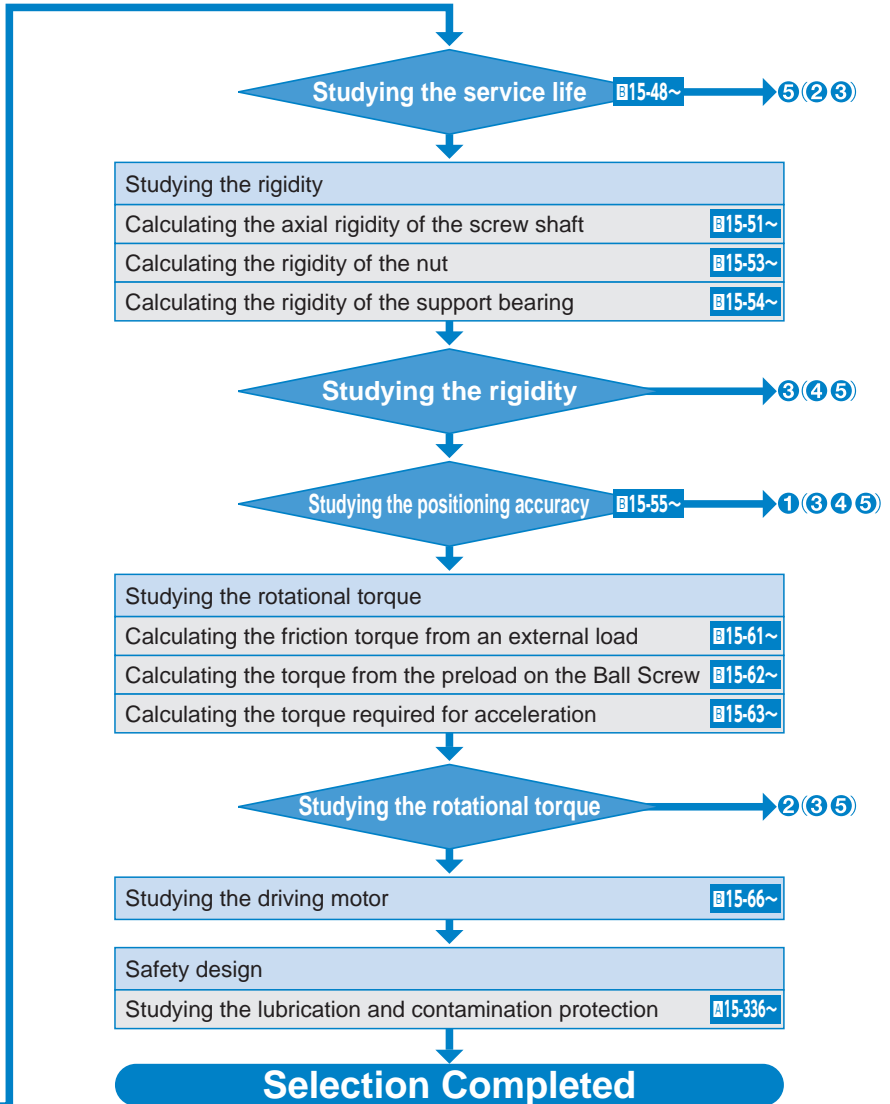

[Conditions of the Ball Screw]

The following conditions are required when selecting a Ball Screw.

Transfer orientation (horizontal, vertical, etc.)
 Transferred mass m (kg)
 Table guide method (sliding, rolling)
 Frictional coefficient of the guide surface μ (—)
 Guide surface resistance f (N)
 External load in the axial direction F (N)
 Desired service life time L_h (h)

Stroke length ℓ_s (mm)
 Operating speed V_{max} (m/s)
 Acceleration time t_1 (s)
 Even speed time t_2 (s)
 Deceleration time t_3 (s)

Acceleration $\alpha = \frac{V_{max}}{t_1}$ (m/s²)

Acceleration distance $\ell_1 = V_{max} \times t_1 \times 1000/2$ (mm)

Even speed distance $\ell_2 = V_{max} \times t_2 \times 1000$ (mm)

Deceleration distance $\ell_3 = V_{max} \times t_3 \times 1000/2$ (mm)

Number of reciprocations per minute n (min⁻¹)

Positioning accuracy (mm)
 Positioning accuracy repeatability (mm)
 Backlash (mm)
 Minimum feed amount s (mm/pulse)

Driving motor (AC servomotor, stepping motor, etc.)

The rated rotation speed of the motor N_{MO} (min⁻¹)

Inertial moment of the motor J_M (kg·m²)

Motor resolution (pulse/rev)

Reduction ratio A (—)

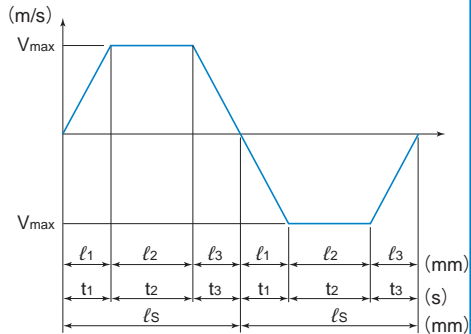

Velocity diagram

Accuracy of the Ball Screw

Lead Angle Accuracy

The accuracy of the Ball Screw in the lead angle is controlled in accordance with the JIS standards (JIS B 1192 - 1997).

Accuracy grades C0 to C5 are defined in the linearity and the directional property, and C7 to C10 in the travel distance error in relation to 300 mm.

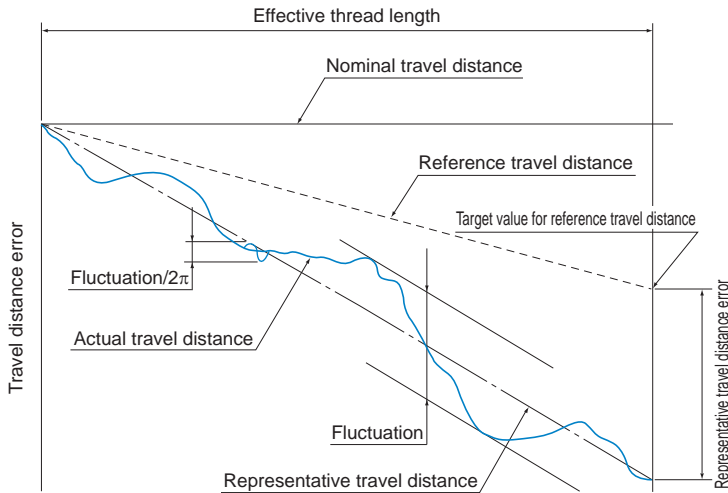

Fig.1 Terms on Lead Angle Accuracy

[Actual Travel Distance]

An error in the travel distance measured with an actual Ball Screw.

[Reference Travel Distance]

Generally, it is the same as nominal travel distance, but can be an intentionally corrected value of the nominal travel distance according to the intended use.

[Target Value for Reference Travel Distance]

You may provide some tension in order to prevent the screw shaft from runout, or set the reference travel distance in "negative" or "positive" value in advance given the possible expansion/contraction from external load or temperature. In such cases, indicate a target value for the reference travel distance.

[Representative Travel Distance]

It is a straight line representing the tendency in the actual travel distance, and obtained with the least squares method from the curve that indicates the actual travel distance.

[Representative Travel Distance Error (in \pm)]

Difference between the representative travel distance and the reference travel distance.

[Fluctuation]

The maximum width of the actual travel distance between two straight lines drawn in parallel with the representative travel distance.

[Fluctuation/300]

Indicates a fluctuation against a given thread length of 300 mm.

[Fluctuation/2 π]

A fluctuation in one revolution of the screw shaft.

Table1 Lead Angle Accuracy (Permissible Value)

Unit: μm

Accuracy grades		Precision Ball Screw										Rolled Ball Screw		
		C0		C1		C2		C3		C5		C7	C8	C10
Effective thread length		Representative travel distance error	Fluctuation	Representative travel distance error	Fluctuation	Representative travel distance error	Fluctuation	Representative travel distance error	Fluctuation	Representative travel distance error	Fluctuation	Travel distance error	Travel distance error	Travel distance error
Above	Or less													
—	100	3	3	3.5	5	5	7	8	8	18	18	±50/ 300mm	±100/ 300mm	±210/ 300mm
100	200	3.5	3	4.5	5	7	7	10	8	20	18			
200	315	4	3.5	6	5	8	7	12	8	23	18			
315	400	5	3.5	7	5	9	7	13	10	25	20			
400	500	6	4	8	5	10	7	15	10	27	20			
500	630	6	4	9	6	11	8	16	12	30	23			
630	800	7	5	10	7	13	9	18	13	35	25			
800	1000	8	6	11	8	15	10	21	15	40	27			
1000	1250	9	6	13	9	18	11	24	16	46	30			
1250	1600	11	7	15	10	21	13	29	18	54	35			
1600	2000	—	—	18	11	25	15	35	21	65	40			
2000	2500	—	—	22	13	30	18	41	24	77	46			
2500	3150	—	—	26	15	36	21	50	29	93	54			
3150	4000	—	—	30	18	44	25	60	35	115	65			
4000	5000	—	—	—	—	52	30	72	41	140	77			
5000	6300	—	—	—	—	65	36	90	50	170	93			
6300	8000	—	—	—	—	—	—	110	60	210	115			
8000	10000	—	—	—	—	—	—	—	—	260	140			

Note) Unit of effective thread length: mm

Table2 Fluctuation in Thread Length of 300 mm and in One Revolution (permissible value)

Unit: μm

Accuracy grades	C0	C1	C2	C3	C5	C7	C8	C10
Fluctuation/300	3.5	5	7	8	18	—	—	—
Fluctuation/ 2π	3	4	5	6	8	—	—	—

Table3 Types and Grades

Type	Series symbol	Grade	Remarks
For positioning	Cp	1, 3, 5	ISO compliant
For transport	Ct	1, 3, 5, 7, 10	

Note) Accuracy grades apply also to the Cp series and Ct series. Contact THK for details.

Point of Selection

Accuracy of the Ball Screw

Example: When the lead of a Ball Screw manufactured is measured with a target value for the reference travel distance of $-9\ \mu\text{m}/500\ \text{mm}$, the following data are obtained.

Table4 Measurement Data on Travel Distance Error

Unit: mm

Command position (A)	0	50	100	150
Travel distance (B)	0	49.998	100.001	149.996
Travel distance error (A-B)	0	-0.002	+0.001	-0.004

Command position (A)	200	250	300	350
Travel distance (B)	199.995	249.993	299.989	349.985
Travel distance error (A-B)	-0.005	-0.007	-0.011	-0.015

Command position (A)	400	450	500
Travel distance (B)	399.983	449.981	499.984
Travel distance error (A-B)	-0.017	-0.019	-0.016

The measurement data are expressed in a graph as shown in Fig.2.

The positioning error (A-B) is indicated as the actual travel distance while the straight line representing the tendency of the (A-B) graph refers to the representative travel distance.

The difference between the reference travel distance and the representative travel distance appears as the representative travel distance error.

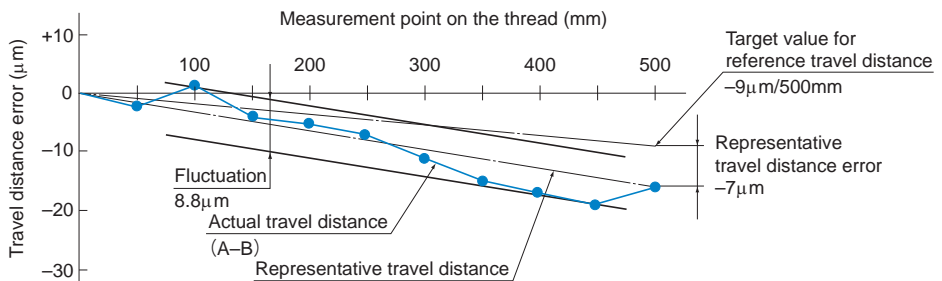

Fig.2 Measurement Data on Travel Distance Error

[Measurements]

Representative travel distance error: $-7\ \mu\text{m}$

Fluctuation: $8.8\ \mu\text{m}$

Accuracy of the Mounting Surface

The accuracy of the Ball Screw mounting surface complies with the JIS standard (JIS B 1192-1997).

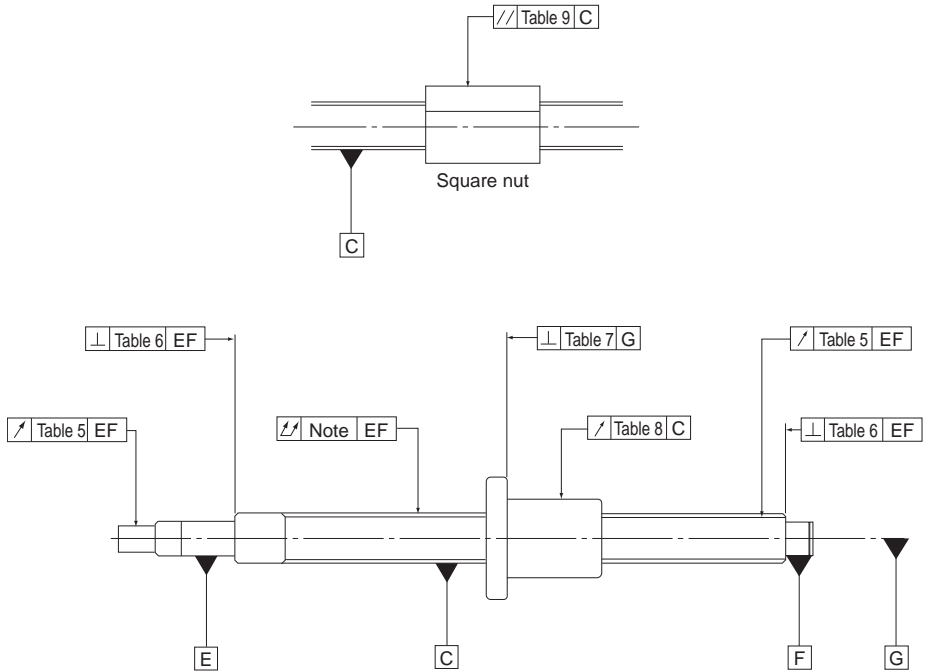

Note) For the overall radial runout of the screw shaft axis, refer to JIS B 1192-1997.

Fig.3 Accuracy of the Mounting Surface of the Ball Screw

[Accuracy Standards for the Mounting Surface]

Table5 to Table9 show accuracy standards for the mounting surfaces of the precision Ball Screw.

Table5 Radial Runout of the Circumference of the Thread Root in Relation to the Supporting Portion Axis of the Screw Shaft
Unit: μm

Screw shaft outer diameter (mm)		Runout (maximum)					
Above	Or less	C0	C1	C2	C3	C5	C7
—	8	3	5	7	8	10	14
8	12	4	5	7	8	11	14
12	20	4	6	8	9	12	14
20	32	5	7	9	10	13	20
32	50	6	8	10	12	15	20
50	80	7	9	11	13	17	20
80	100	—	10	12	15	20	30

Note) The measurements on these items include the effect of the runout of the screw shaft diameter. Therefore, it is necessary to obtain the correction value from the overall runout of the screw shaft axis, using the ratio of the distance between the fulcrum and measurement point to the overall screw shaft length, and add the obtained value to the table above.

Example: model No. DIK2005-6RRGO+500LC5

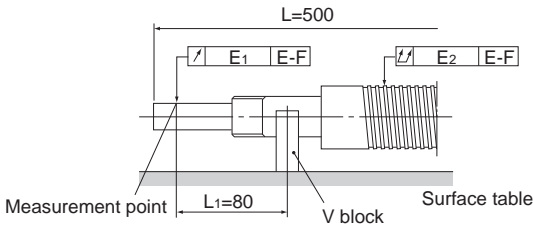

$$E_1 = e + \Delta e$$

e : Standard value in Table5(0.012)

Δe : Correction value

$$\Delta e = \frac{L_1}{L} \times E_2$$

$$= \frac{80}{500} \times 0.06$$

$$= 0.01$$

L : Overall screw shaft length

L_1 : Distance between the fulcrum and the measurement point

E_2 : Overall radial runout of the screw shaft axis (0.06)

$$E_1 = 0.012 + 0.01$$

$$= 0.022$$

Note) For the overall radial runout of the screw shaft axis, refer to JIS B 1192-1997.

Table6 Perpendicularity of the Supporting Portion End of the Screw Shaft to the Supporting Portion Axis

Unit: μm

Screw shaft outer diameter (mm)		Perpendicularity (maximum)					
Above	Or less	C0	C1	C2	C3	C5	C7
—	8	2	3	3	4	5	7
8	12	2	3	3	4	5	7
12	20	2	3	3	4	5	7
20	32	2	3	3	4	5	7
32	50	2	3	3	4	5	8
50	80	3	4	4	5	7	10
80	100	—	4	5	6	8	11

Table7 Perpendicularity of the Flange Mounting Surface of the Screw Shaft to the Screw Shaft Axis

Unit: μm

Nut diameter (mm)		Perpendicularity (maximum)					
Above	Or less	C0	C1	C2	C3	C5	C7
—	20	5	6	7	8	10	14
20	32	5	6	7	8	10	14
32	50	6	7	8	8	11	18
50	80	7	8	9	10	13	18
80	125	7	9	10	12	15	20
125	160	8	10	11	13	17	20
160	200	—	11	12	14	18	25

Table8 Radial Runout of the Nut Circumference in Relation to the Screw Shaft Axis

Unit: μm

Nut diameter (mm)		Runout (maximum)					
Above	Or less	C0	C1	C2	C3	C5	C7
—	20	5	6	7	9	12	20
20	32	6	7	8	10	12	20
32	50	7	8	10	12	15	30
50	80	8	10	12	15	19	30
80	125	9	12	16	20	27	40
125	160	10	13	17	22	30	40
160	200	—	16	20	25	34	50

Table9 Parallelism of the Nut Circumference (Flat Mounting Surface) to the Screw Shaft Axis

Unit: μm

Mounting reference length (mm)		Parallelism (maximum)					
Above	Or less	C0	C1	C2	C3	C5	C7
—	50	5	6	7	8	10	17
50	100	7	8	9	10	13	17
100	200	—	10	11	13	17	30

[Method for Measuring Accuracy of the Mounting Surface]

● Radial Runout of the Circumference of the Motor-mounting Shaft-end in Relation to the Bearing Journals of the Screw Shaft (see Table5 on [B15-23](#))

Support the end journal of the screw shaft on V blocks. Place a probe on the circumference of the motor-mounting shaft-end, and record the largest difference on the dial gauge as a measurement while rotating the screw shaft through one revolution.

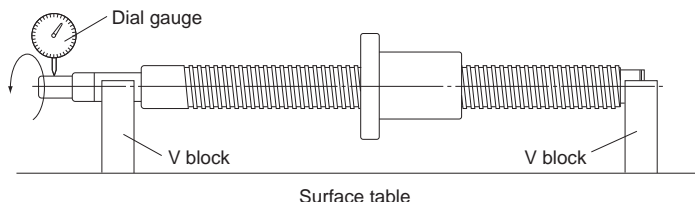

Surface table

● **Radial Runout of the Circumference of the Raceway Threads in Relation to the Bearing Journals of the Screw Shaft (see Table5 on B15-23)**

Support the end journal of the screw shaft on V blocks. Place a probe on the circumference of the nut, and record the largest difference on the dial gauge as a measurement while rotating the screw shaft by one revolution without rotating the nut.

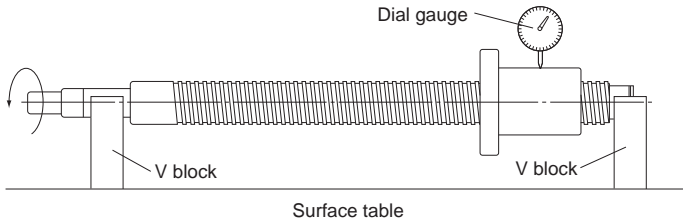

● **Perpendicularity of the End Journal of the Screw Shaft to the Bearing Journals (see Table6 on B15-24)**

Support the bearing journal portions of the screw shaft on V blocks. Place a probe on the screw shaft's supporting portion end, and record the largest difference on the dial gauge as a measurement while rotating the screw shaft through one revolution.

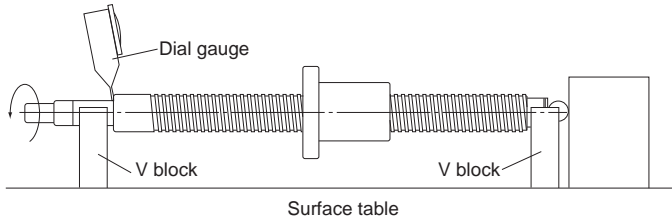

● **Perpendicularity of the Flange Mounting Surface of the Screw Shaft to the Bearing Journals (see Table7 on B15-24)**

Support the thread of the screw shaft on V blocks near the nut. Place a probe on the flange end, and record the largest difference on the dial gauge as a measurement while simultaneously rotating the screw shaft and the nut through one revolution.

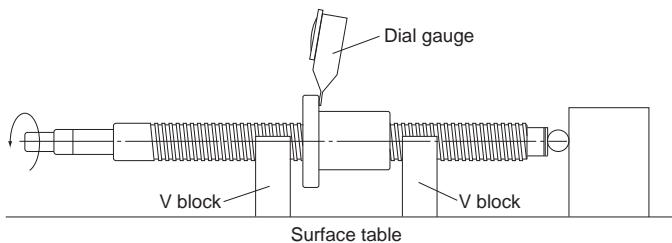

● **Radial Runout of the Nut Circumference in Relation to the Screw Shaft Axis (see Table 8 on B15-24)**

Support the thread of the screw shaft on V blocks near the nut. Place a probe on the circumference of the nut, and record the largest difference on the dial gauge as a measurement while rotating the nut through one revolution without rotating the screw shaft.

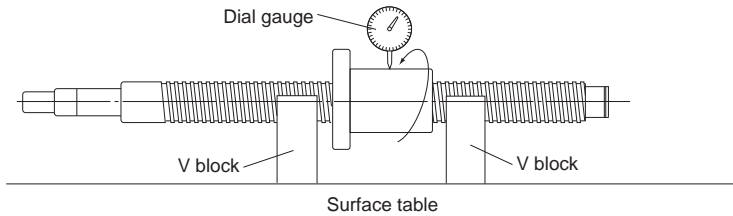

● **Parallelism of the Nut Circumference (Flat Mounting Surface) to the Screw Shaft Axis (see Table 9 on B15-24)**

Support the thread of the screw shaft on V blocks near the nut. Place a probe on the circumference of the nut (flat mounting surface), and record the largest difference on the dial gauge as a measurement while moving the dial gauge in parallel with the screw shaft.

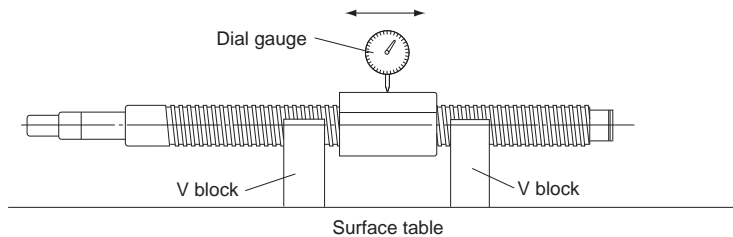

● **Overall Radial Runout of the Screw Shaft Axis**

Support the supporting portion of the screw shaft on V blocks. Place a probe on the circumference of the screw shaft, and record the largest difference on the dial gauge at several points in the axial directions as a measurement while rotating the screw shaft through one revolution.

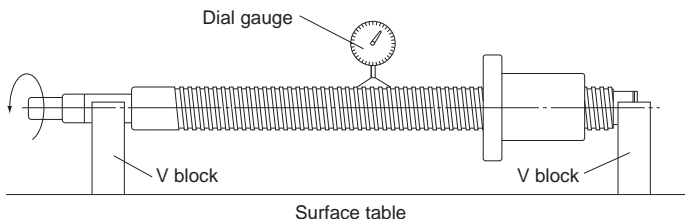

Note) For the overall radial runout of the screw shaft axis, refer to JIS B 1192-1997.

Axial Clearance

[Axial Clearance of the Precision Ball Screw]

Table10 shows the axial clearance of the precision Screw Ball. If the manufacturing length exceeds the value in Table11, the resultant clearance may partially be negative (preload applied).

The manufacturing limit lengths of the Ball Screws compliant with the DIN standard are provided in Table12.

For the axial clearance of the Precision Caged Ball Screw, see **A15-72** to **A15-89**.

Table10 Axial Clearance of the Precision Ball Screw

Unit: mm

Clearance symbol	G0	GT	G1	G2	G3
Axial Clearance	0 or less	0 to 0.005	0 to 0.01	0 to 0.02	0 to 0.05

Table11 Maximum Length of the Precision Ball Screw in Axial Clearance

Unit: mm

Screw shaft outer diameter	Clearance GT				Clearance G1				Clearance G2					
	C0	C1	C2•C3	C5	C0	C1	C2•C3	C5	C0	C1	C2	C3	C5	C7
4•6	80	80	80	100	80	80	80	100	80	80	80	80	100	120
8	230	250	250	200	230	250	250	250	230	250	250	250	300	300
10	250	250	250	200	250	250	250	250	250	250	250	250	300	300
12•13	440	500	500	400	440	500	500	500	440	500	630	680	600	500
14	500	500	500	400	500	500	500	500	530	620	700	700	600	500
15	500	500	500	400	500	500	500	500	570	670	700	700	600	500
16	500	500	500	400	500	500	500	500	620	700	700	700	600	500
18	720	800	800	700	720	800	800	700	720	840	1000	1000	1000	1000
20	800	800	800	700	800	800	800	700	820	950	1000	1000	1000	1000
25	800	800	800	700	800	800	800	700	1000	1000	1000	1000	1000	1000
28	900	900	900	800	1100	1100	1100	900	1300	1400	1400	1400	1200	1200
30•32	900	900	900	800	1100	1100	1100	900	1400	1400	1400	1400	1200	1200
36•40•45	1000	1000	1000	800	1300	1300	1300	1000	2000	2000	2000	2000	1500	1500
50•55•63•70	1200	1200	1200	1000	1600	1600	1600	1300	2000	2500	2500	2500	2000	2000
80•100	—	—	—	—	1800	1800	1800	1500	2000	4000	4000	4000	3000	3000

*When manufacturing the Ball Screw of precision-grade accuracy C7 with clearance GT or G1, the resultant clearance is partially negative.

Table12 Manufacturing limit lengths of precision Ball Screws with axial clearances (DIN standard compliant Ball Screws)

Unit: mm

Shaft diameter	Clearance GT		Clearance G1		Clearance G2		
	C3, Cp3	C5, Cp5, Ct5	C3, Cp3	C5, Cp5, Ct5	C3, Cp3	C5, Cp5, Ct5	C7, Cp7
16	500	400	500	500	700	600	500
20, 25	800	700	800	700	1000	1000	1000
32	900	800	1100	900	1400	1200	1200
40	1000	800	1300	1000	2000	1500	1500
50, 63	1200	1000	1600	1300	2500	2000	2000

*When manufacturing the Ball Screw of precision-grade accuracy C7 (Ct7) with clearance GT or G1, the resultant clearance is partially negative.

[Axial Clearance of the Rolled Ball Screw]

Table13 shows axial clearance of the rolled Ball Screw.

Table13 Axial Clearance of the Rolled Ball Screw

Unit: mm

Screw shaft outer diameter	Axial clearance (maximum)
6 to 12	0.05
14 to 28	0.1
30 to 32	0.14
36 to 45	0.17
50	0.2

Preload

A preload is provided in order to eliminate the axial clearance and minimize the displacement under an axial load.

When performing a highly accurate positioning, a preload is generally provided.

[Rigidity of the Ball Screw under a Preload]

When a preload is provided to the Ball Screw, the rigidity of the nut is increased.

Fig.4 shows elastic displacement curves of the Ball Screw under a preload and without a preload.

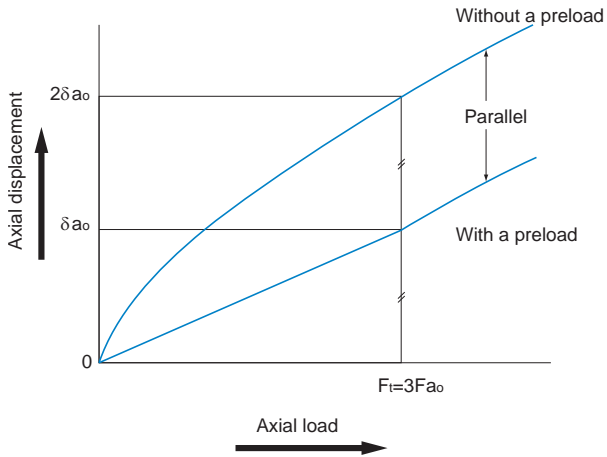
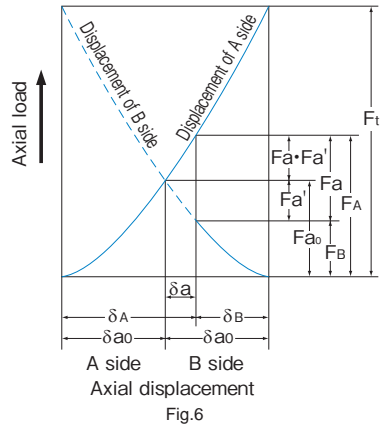
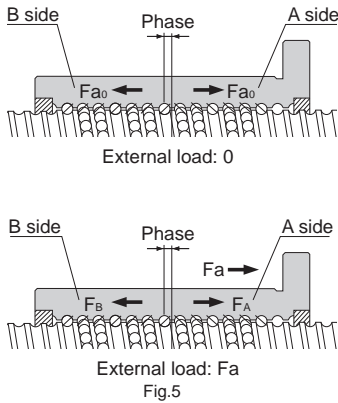

Fig.4 Elastic Displacement Curve of the Ball Screw

Fig.5 shows a single-nut type of the Ball Screw.



The A and B sides are provided with preload F_{a0} by changing the groove pitch in the center of the nut to create a phase. Because of the preload, the A and B sides are elastically displaced by δ_{a0} each. If an axial load (F_a) is applied from outside in this state, the displacement of the A and B sides is calculated as follows.

$$\delta_A = \delta_{a0} + \delta a \quad \delta_B = \delta_{a0} - \delta a$$

In other words, the loads on the A and B sides are expressed as follows:

$$F_A = F_{a0} + (F_a - F_{a'}) \quad F_B = F_{a0} - F_{a'}$$

Therefore, under a preload, the load that the A side receives equals to $F_a - F_{a'}$. This means that since load $F_{a'}$, which is applied when the A side receives no preload, is deducted from F_a , the displacement of the A side is smaller.

This effect extends to the point where the displacement (δ_{a0}) caused by the preload applied on the B side reaches zero.

To what extent is the elastic displacement reduced? The relationship between the axial load on the Ball Screw under no preload and the elastic displacement can be expressed by $\delta_a \propto F_a^{2/3}$. From Fig.6, the following equations are established.

$$\delta_{a0} = K F_{a0}^{2/3} \quad (K : \text{constant})$$

$$2\delta_{a0} = K F_t^{2/3}$$

$$\left(\frac{F_t}{F_{a0}}\right)^{2/3} = 2 \quad F_t = 2^{3/2} \times F_{a0} = 2.8F_{a0} \doteq 3F_{a0}$$

Thus, the Ball Screw under a preload is displaced by δ_{a0} when an axial load (F_t) approximately three times greater than the preload is provided from outside. As a result, the displacement of the Ball Screw under a preload is half the displacement ($2\delta_{a0}$) of the Ball Screw without a preload.

As stated above, since the preloading is effective up to approximately three times the applied preload, the optimum preload is one third of the maximum axial load.

Note that an excessive preload adversely affects the service life and heat generation. The maximum pre-load should be set at 10% of the basic dynamic load rating (C_a) in the axial direction.

[Preload Torque]

The preload torque of the Ball Screw in lead is controlled in accordance with the JIS standard (JIS B 1192-1997).

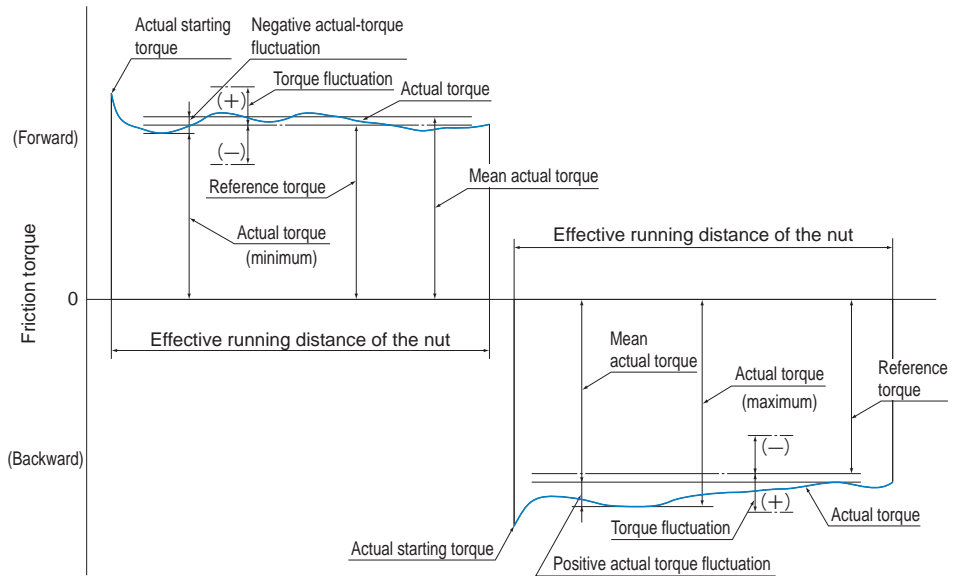

Fig.7 Terms on Preload Torque

● Dynamic Preload Torque

A torque required to continuously rotate the screw shaft of a Ball Screw under a given preload without an external load applied.

● Actual Torque

A dynamic preload torque measured with an actual Ball Screw.

● Torque Fluctuation

Variation in a dynamic preload torque set at a target value. It can be positive or negative in relation to the reference torque.

● Coefficient of Torque Fluctuation

Ratio of torque fluctuation to the reference torque.

● Reference Torque

A dynamic preload torque set as a target.

● Calculating the Reference Torque

The reference torque of a Ball Screw provided with a preload is obtained in the following equation (4).

$$T_p = 0.05 (\tan\beta)^{-0.5} \frac{F_{a0} \cdot Ph}{2\pi} \dots\dots(4)$$

T_p : Reference torque (N-mm)

β : Lead angle

F_{a0} : Applied preload (N)

Ph : Lead (mm)

Example of calculating the preload torque

When a preload of 3,000 N is provided to the Ball Screw model BIF4010-10G0 + 1500LC3 with a thread length of 1,300 mm (shaft diameter: 40 mm; ball center-to-center diameter: 41.75 mm; lead: 10 mm), the preload torque of the Ball Screw is calculated in the steps below.

■Calculating the Reference Torque

β : Lead angle

$$\tan\beta = \frac{\text{lead}}{\pi \times \text{ball center-to-center diameter}} = \frac{10}{\pi \times 41.75} = 0.0762$$

F_{a0} : Applied preload=3000N

Ph : Lead = 10mm

$$T_p = 0.05 (\tan\beta)^{-0.5} \frac{F_{a0} \cdot Ph}{2\pi} = 0.05 (0.0762)^{-0.5} \frac{3000 \times 10}{2\pi} = 865 \text{ N} \cdot \text{mm}$$

■Calculating the Torque Fluctuation

$$\frac{\text{thread length}}{\text{screw shaft outer diameter}} = \frac{1300}{40} = 32.5 \leq 40$$

Thus, with the reference torque in Table14 being between 600 and 1,000 N·mm, effective thread length 4,000 mm or less and accuracy grade C3, the coefficient of torque fluctuation is obtained as $\pm 30\%$.

As a result, the torque fluctuation is calculated as follows.

$$865 \times (1 \pm 0.3) = 606 \text{ N} \cdot \text{mm} \text{ to } 1125 \text{ N} \cdot \text{mm}$$

■Result

Reference torque : 865 N·mm

Torque fluctuation : 606 N·mm to 1125 N·mm

Table14 Tolerance Range in Torque Fluctuation

Reference torque N·mm		Effective thread length													
		4000mm or less											Above 4,000 mm and 10,000 mm or less		
		$\frac{\text{thread length}}{\text{screw shaft outer diameter}} \leq 40$						$40 < \frac{\text{thread length}}{\text{screw shaft outer diameter}} < 60$					—		
		Accuracy grades						Accuracy grades					Accuracy grades		
Above	Or less	C0	C1	C3	C5	C7	C0	C1	C3	C5	C7	C3	C5	C7	
200	400	±30%	±35%	±40%	±50%	—	±40%	±40%	±50%	±60%	—	—	—	—	
400	600	±25%	±30%	±35%	±40%	—	±35%	±35%	±40%	±45%	—	—	—	—	
600	1000	±20%	±25%	±30%	±35%	±40%	±30%	±30%	±35%	±40%	±45%	±40%	±45%	±50%	
1000	2500	±15%	±20%	±25%	±30%	±35%	±25%	±25%	±30%	±35%	±40%	±35%	±40%	±45%	
2500	6300	±10%	±15%	±20%	±25%	±30%	±20%	±20%	±25%	±30%	±35%	±30%	±35%	±40%	
6300	10000	—	±15%	±15%	±20%	±30%	—	—	±20%	±25%	±35%	±25%	±30%	±35%	

Selecting a Screw Shaft

Maximum Length of the Screw Shaft

Table15 shows the manufacturing limit lengths of precision Ball Screws by accuracy grades, Table16 shows the manufacturing limit lengths of precision Ball Screws compliant with DIN standard by accuracy grades, and Table17 shows the manufacturing limit lengths of rolled Ball Screws by accuracy grades.

If the shaft dimensions exceed the manufacturing limit in Table15, Table16 or Table17, contact THK.

Table15 Maximum Length of the Precision Ball Screw by Accuracy Grade

Unit: mm

Screw shaft outer diameter	Overall screw shaft length						
	C0	C1	C2	C3	C5	C7	
4	90	110	120	120	120	120	
6	150	170	210	210	210	210	
8	230	270	340	340	340	340	
10	350	400	500	500	500	500	
12	440	500	630	680	680	680	
13	440	500	630	680	680	680	
14	530	620	770	870	890	890	
15	570	670	830	950	980	1100	
16	620	730	900	1050	1100	1400	
18	720	840	1050	1220	1350	1600	
20	820	950	1200	1400	1600	1800	
25	1100	1400	1600	1800	2000	2400	
28	1300	1600	1900	2100	2350	2700	
30	1450	1700	2050	2300	2570	2950	
32	1600	1800	2200	2500	2800	3200	
36	2000	2100	2550	2950	3250	3650	
40		2400	2900	3400	3700	4300	
45		2750	3350	3950	4350	5050	
50		3100	3800	4500	5000	5800	
55		3450	4150	5300	6050	6500	
63		4000	6300	5200	5800	6700	7700
70				6450	7650	9000	
80				7900	9000	10000	
100				10000	10000		

Point of Selection

Selecting a Screw Shaft

Table16 Manufacturing limit lengths of precision Ball Screws (DIN standard compliant Ball Screws)

Unit: mm

Shaft diameter	Ground shaft			CES shaft			
	C3	C5	C7	Cp3	Cp5	Ct5	Ct7
16	1050	1100	1400	1050	1100	1100	1400
20	1400	1600	1800	1400	1600	1600	1800
25	1800	2000	2400	1800	2000	2000	2400
32	2500	2800	3200	2500	2800	2800	3200
40	3400	3700	4300	3400	3700	3700	4300
50	4500	5000	5800	—	—	—	—
63	5800	6700	7700	—	—	—	—

Table17 Maximum Length of the Rolled Ball Screw by Accuracy Grade

Unit: mm

Screw shaft outer diameter	Overall screw shaft length		
	C7	C8	C10
6 to 8	320	320	—
10 to 12	500	1000	—
14 to 15	1500	1500	1500
16 to 18	1500	1800	1800
20	2000	2200	2200
25	2000	3000	3000
28	3000	3000	3000
30	3000	3000	4000
32 to 36	3000	4000	4000
40	3000	5000	5000
45	3000	5500	5500
50	3000	6000	6000

Standard Combinations of Shaft Diameter and Lead for the Precision Ball Screw

Table18 shows standard combinations of shaft diameters and leads of precision Ball Screws, and Table19 shows standard combinations of shaft diameters and leads of precision Ball Screws compliant with DIN standard.

For standard combinations of shaft diameter and lead of the Precision Caged Ball Screw, see **A15-72** to **A15-89**.

If a Ball Screw not covered by the table is required, contact THK.

Table18 Standard Combinations of Screw Shaft and Lead (Precision Ball Screw)

Unit: mm

Screw shaft outer diameter	Lead																						
	1	2	4	5	6	8	10	12	15	16	20	24	25	30	32	36	40	50	60	80	90	100	
4	●																						
5	●																						
6	●																						
8	●	●					●	○															
10		●	●				●		○														
12		●		●			●																
13														○									
14		●	●	●			●																
15							●				●			○			○						
16			○	●	○		○			●													
18							●																
20			○	●	○	○	●	○			●						○		○				
25			○	●	○	○	●	○		○	●		○					○					
28				○	●	○	○																
30																			○			○	
32			○	●	●	○	●	○			○					○							
36					○	○	●	○		○	○	○					○						
40				○	○	○	●	●		○	○			○			○				○		
45					○	○	○	○		○	○												
50				○		○	●			○	○			○		○		○					○
55							○	○		○	○			○		○		○					
63							○	○		○	○												
70							○	○			○												
80							○	○			○												
100											○												
120																							

●: Standardized Screw Shafts (Unfinished Shaft Ends/Finished Shaft Ends)

○: Semi-standard stock

Table19 Standard combinations of outer diameters and leads of the screw shafts (DIN standard compliant Ball Screws)

Unit: mm

Shaft diameter	Lead		
	5	10	20
16	●	—	—
20	●	—	—
25	●	●	—
32	●	●	—
40	○	●	○*
50	—	○	○*
63	—	○	○*

●: Ground shaft, CES shaft

○: Ground shaft only

*: Model EB (no preload) only

Standard Combinations of Shaft Diameter and Lead for the Rolled Ball Screw

Table20 shows the standard combinations of shaft diameter and lead for the rolled Ball Screw.

Table20 Standard Combinations of Screw Shaft and Lead (Rolled Ball Screw)

Unit: mm

Screw shaft outer diameter	Lead																			
	1	2	4	5	6	8	10	12	16	20	24	25	30	32	36	40	50	60	80	100
6	●																			
8		●																		
10		●			○															
12		●				○														
14			●	●																
15							●		●		●									
16				●					●											
18						●														
20				●			●		●							●				
25				●			●					●					●			
28					●															
30																	●			
32							●						●							
36							●		●	●					●					
40							●									●			●	
45								●												
50									●								●			●

- : Standard stock
○: Semi-standard stock

Method for Mounting the Ball Screw Shaft

Fig.1 to Fig.4 show the representative mounting methods for the screw shaft.

The permissible axial load and the permissible rotational speed vary with mounting methods for the screw shaft. Therefore, it is necessary to select an appropriate mounting method according to the conditions.

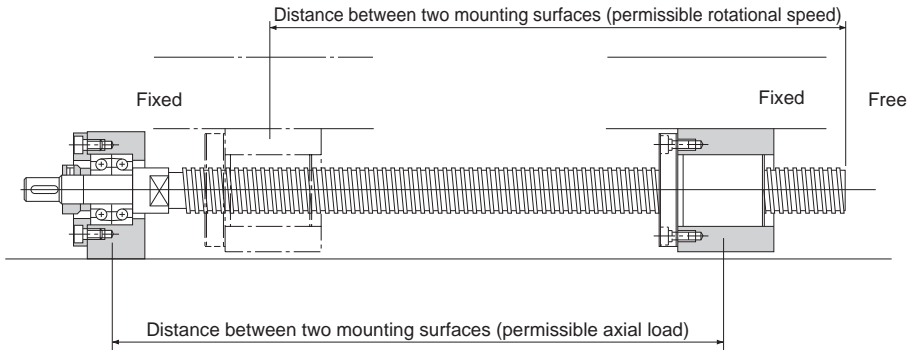

Fig.1 Screw Shaft Mounting Method: Fixed - Free

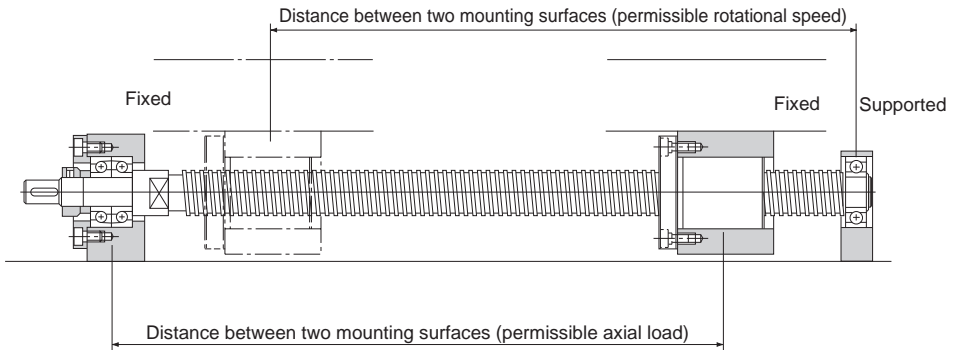

Fig.2 Screw Shaft Mounting Method: Fixed - Supported

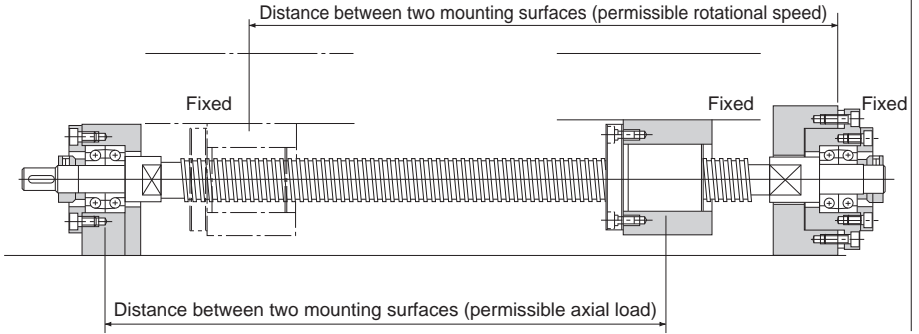

Fig.3 Screw Shaft Mounting Method: Fixed - Fixed

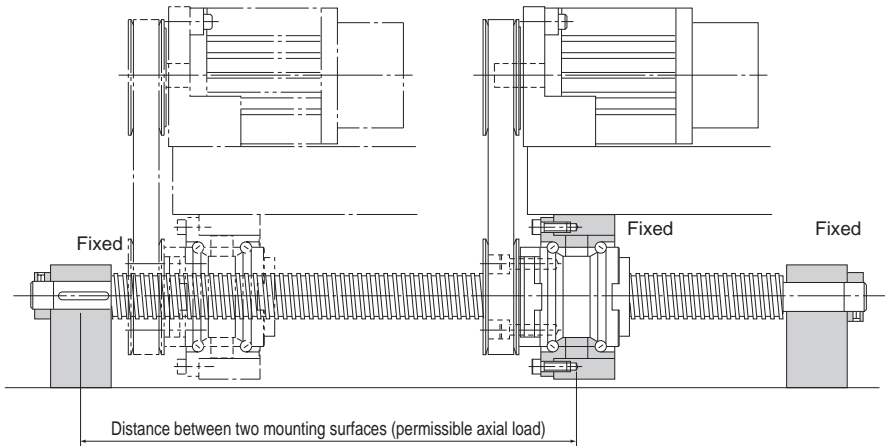

Fig.4 Screw Shaft Mounting Method for Rotary Nut Ball Screw: Fixed - Fixed

Permissible Axial Load

[Buckling Load on the Screw Shaft]

With the Ball Screw, it is necessary to select a screw shaft so that it will not buckle when the maximum compressive load is applied in the axial direction.

Fig.5 on **B15-39** shows the relationship between the screw shaft diameter and a buckling load. If determining a buckling load by calculation, it can be obtained from the equation (5) below. Note that in this equation, a safety factor of 0.5 is multiplied to the result.

$$P_1 = \frac{\eta_1 \cdot \pi^2 \cdot E \cdot I}{\ell_a^2} \cdot 0.5 = \eta_2 \frac{d_1^4}{\ell_a^2} \cdot 10^4 \quad \dots\dots(5)$$

P_1 : Buckling load (N)

ℓ_a : Distance between two mounting surfaces (mm)

E : Young's modulus (2.06×10^5 N/mm²)

I : Minimum geometrical moment of inertia of the shaft (mm⁴)

$$I = \frac{\pi}{64} d_1^4 \quad d_1: \text{screw-shaft thread minor diameter (mm)}$$

η_1, η_2 : Factor according to the mounting method

Fixed - free $\eta_1=0.25$ $\eta_2=1.3$

Fixed - supported $\eta_1=2$ $\eta_2=10$

Fixed - fixed $\eta_1=4$ $\eta_2=20$

[Permissible Tensile Compressive Load on the Screw Shaft]

If an axial load is applied to the Ball Screw, it is necessary to take into account not only the buckling load but also the permissible tensile compressive load in relation to the yielding stress on the screw shaft.

The permissible tensile compressive load is obtained from the equation (6).

$$P_2 = \sigma \frac{\pi}{4} d_1^2 = 116d_1^2 \quad \dots\dots(6)$$

P_2 : Permissible tensile compressive load (N)

σ : Permissible tensile compressive stress (147 MPa)

d_1 : Screw-shaft thread minor diameter (mm)

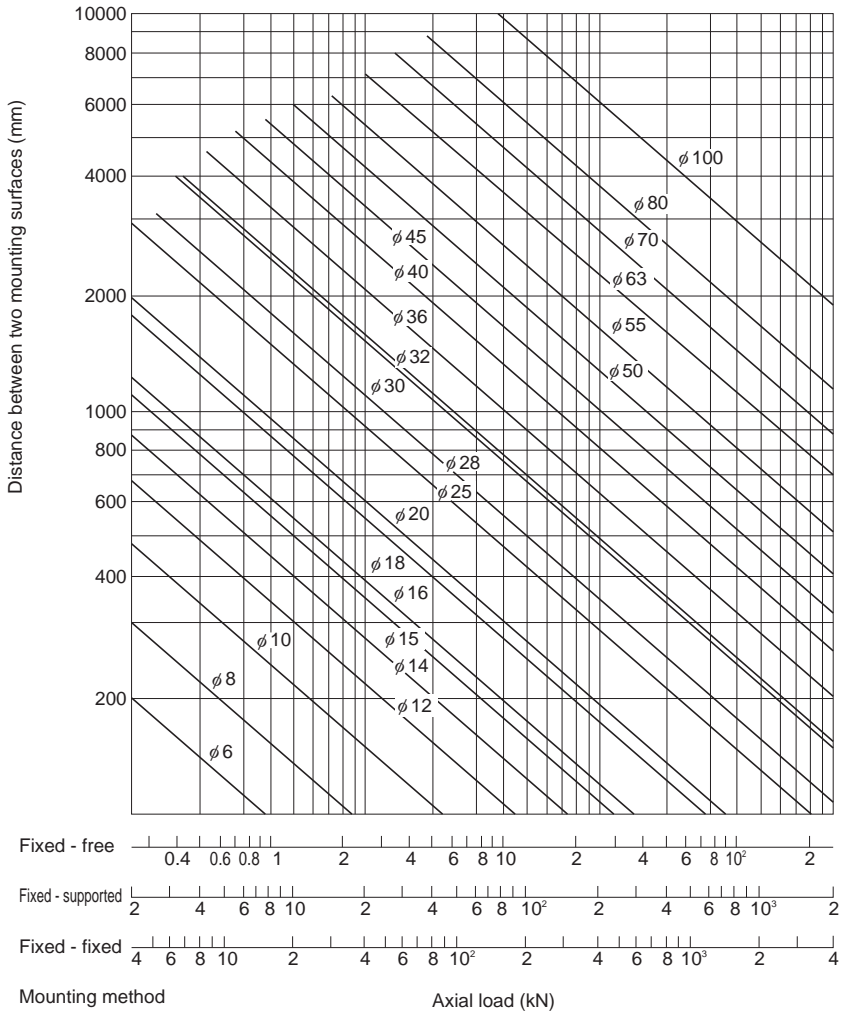

Fig.5 Permissible Tensile Compressive Load Diagram

Permissible Rotational Speed

[Dangerous Speed of the Screw Shaft]

When the rotational speed reaches a high magnitude, the Ball Screw may resonate and eventually become unable to operate due to the screw shaft's natural frequency. Therefore, it is necessary to select a model so that it is used below the resonance point (dangerous speed).

Fig.6 on **B15-42** shows the relationship between the screw shaft diameter and a dangerous speed.

If determining a dangerous speed by calculation, it can be obtained from the equation (7) below. Note that in this equation, a safety factor of 0.8 is multiplied to the result.

$$N_1 = \frac{60 \cdot \lambda_1^2}{2\pi \cdot \ell_b^2} \times \sqrt{\frac{E \times 10^3 \cdot I}{\gamma \cdot A}} \times 0.8 = \lambda_2 \cdot \frac{d_1}{\ell_b^2} \cdot 10^7 \quad \dots\dots(7)$$

N_1 : Permissible rotational speed determined
by dangerous speed (min⁻¹)

ℓ_b : Distance between two mounting surfaces
(mm)

E : Young's modulus (2.06 × 10⁵ N/mm²)

I : Minimum geometrical moment of inertia
of the shaft (mm⁴)

$$I = \frac{\pi}{64} d_1^4 \quad d_1: \text{screw-shaft thread minor diameter (mm)}$$

γ : Density (specific gravity)
(7.85 × 10⁶kg/mm³)

A : Screw shaft cross-sectional area (mm²)

$$A = \frac{\pi}{4} d_1^2$$

λ_1, λ_2 : Factor according to the mounting method

Fixed - free $\lambda_1=1.875$ $\lambda_2=3.4$

Supported - supported $\lambda_1=3.142$ $\lambda_2=9.7$

Fixed - supported $\lambda_1=3.927$ $\lambda_2=15.1$

Fixed - fixed $\lambda_1=4.73$ $\lambda_2=21.9$

Point of Selection

Permissible Rotational Speed

[DN Value]

The permissible rotational speed of the Ball Screw must be obtained from the dangerous speed of the screw shaft and the DN value.

The permissible rotational speed determined by the DN value is obtained using the equations (8) to (16) below.

Precision	Caged Ball	Large Lead	Model SBK (SBK3636, SBK4040 and SBK5050)	$N_2 = \frac{210000}{D}$(8-1)
			Model SBK (Other than the above model numbers and the small size model SBK*)	$N_2 = \frac{160000}{D}$(8-2)
		Standard lead	Model SBN-V (Medium)	$N_2 = \frac{160000}{D}$(9-1)
			Models SBN-V (Small), HBN, and SBKH	$N_2 = \frac{130000}{D}$(9-2)
	Full- Complement Ball	Super Lead	Model WHF	$N_2 = \frac{120000}{D}$(10-1)
			Model WGF	$N_2 = \frac{70000}{D}$(10-2)
		Large Lead	Models BLW, BLK, BLR, BNS and NS	$N_2 = \frac{70000}{D}$(11)
			Standard lead	Models BIF-V (Medium), BNFN-V (Medium), and BNF (Medium)
		Models BIF-V (Small), BNFN-V (Small), and BNF (Small)		$N_2 = \frac{100000}{D}$(12-2)
		Models BIF, DIK, BNFN, DKN, BNF, BNT, DK, MDK, MBF, BNK and DIR	$N_2 = \frac{70000}{D}$(12-3)	
Full-Complement Ball (DIN Standard Compliant)	Standard lead	Models EBA, EBB, EBC, EPA, EPB and EPC	$N_2 = \frac{100000}{D}$(13)	
Rolled	Full- Complement Ball	Super Lead	Model WHF	$N_2 = \frac{100000}{D}$(14-1)
			Models WTF and CNF	$N_2 = \frac{70000}{D}$(14-2)
		Large Lead	Models BLK and BLR	$N_2 = \frac{70000}{D}$(15)
		Standard lead	Model BTK-V	$N_2 = \frac{100000}{D}$(16-1)
			Models JPF, BNT and MTF	$N_2 = \frac{50000}{D}$(16-2)

N_2 : Permissible rotational speed determined by the DN value (min⁻¹(rpm))

D : Ball center-to-center diameter

(indicated in the specification tables of the respective model number)

Of the permissible rotational speed determined by dangerous speed (N_1) and the permissible rotational speed determined by DN value (N_2), the lower rotational speed is regarded as the permissible rotational speed.

For small size SBK (SBK1520 to 3232) and SDA, the permissible rotational speed (N_2) is the maximum permissible rotational speed shown in the dimensional tables.(See dimensional tables on pages **A15-76** to **A15-77**, and **A15-80** to **A15-85**)

If the service rotational speed exceeds N_2 , contact THK.

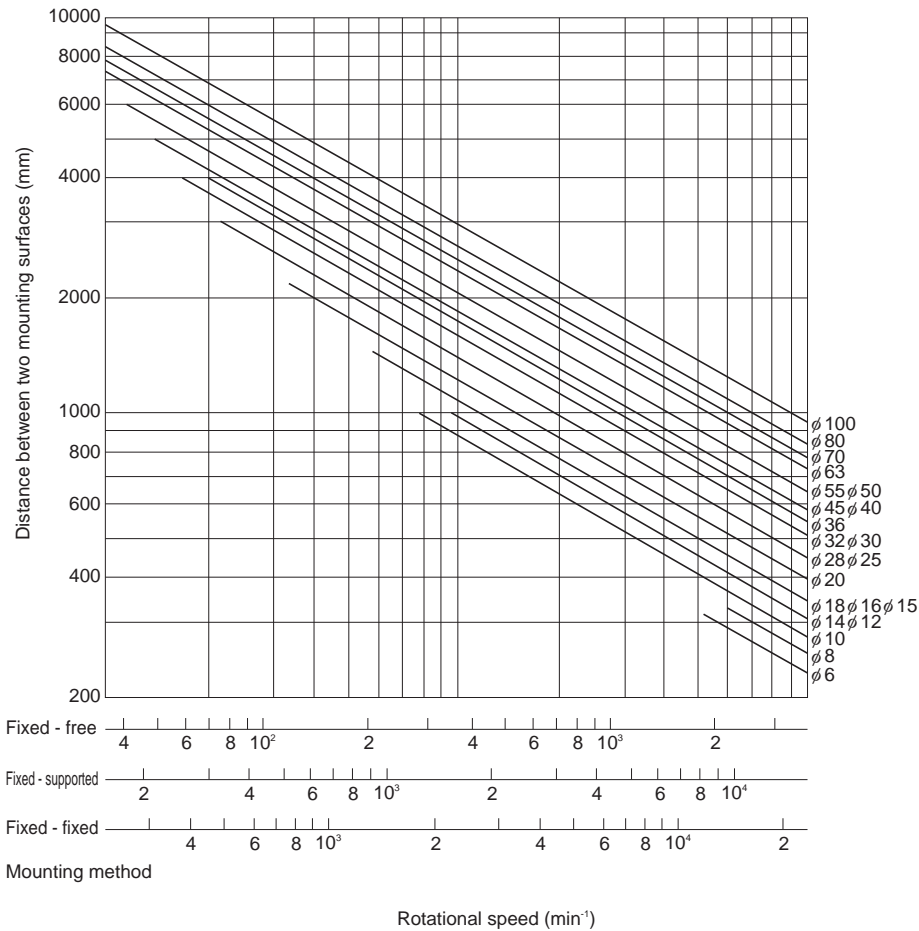

Fig.6 Permissible Rotational Speed Diagram

Selecting a Nut

Types of Nuts

The nuts of the Ball Screws are categorized by the ball circulation method into the return-pipe type, the deflector type and end cap type. These three nut types are described as follows.

In addition to the circulation methods, the Ball Screws are categorized also by the preloading method.

[Types by Ball Circulation Method]

● Return-Pipe Type

(Models SBN-V (Medium), BIF-V (Medium), BIF, BNF-V (Medium), BNF, BNFN-V (Medium), BNFN, BNT, BTK-V),
Return-Piece Type
(Models SBN-V (Small), HBN, BIF-V (Small), BNF-V (Small), BNFN-V (Small))

These are most common types of nuts that use a return pipe for ball circulation. The return pipe allows balls to be picked up, pass through the pipe, and return to their original positions to complete infinite motion.

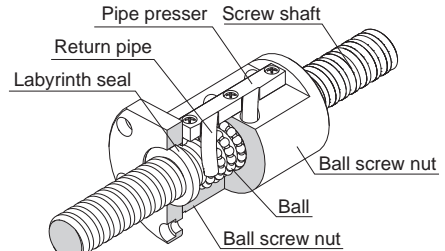

Example of Structure of Return-Pipe Nut

● Deflector Type

(Models EB, EP, DK, DKN, DIK, JPF, DIR and MDK)

These are the most compact type of nut. The balls change their traveling direction with a deflector, pass over the circumference of the screw shaft, and return to their original positions to complete an infinite motion.

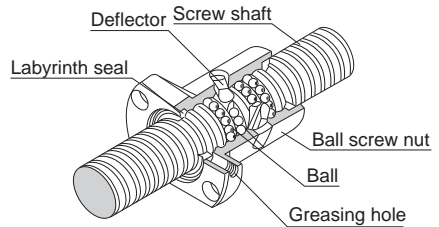

Example of Structure of Simple Nut

● End-cap Type: Large lead Nut (Models SBK, SBKH, WHF, BLK, WGF, BLW, WTF, CNF and BLR)

These nuts are most suitable for the fast feed. The balls are picked up with an end cap, pass through the through hole of the nut, and return to their original positions to complete an infinite motion.

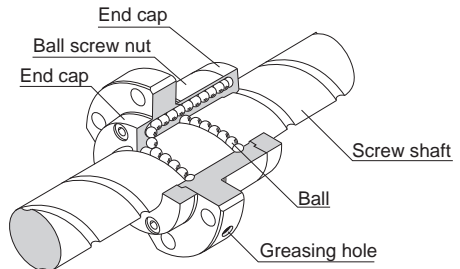

Example of Structure of Large lead Nut

[Types by Preloading Method]

● Fixed-point Preloading

■ Double-nut Preload (Models BNFN-V, BNFN, DKN and BLW)

A spacer is inserted between two nuts to provide a preload.

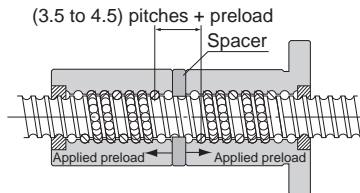

Models BNFN-V and BNFN



Model DKN



Model BLW

■ Offset Preload (Models SBN-V, EP, BIF-V, BIF, DIK, DIR and SBK)

More compact than the double-nut method, the offset preloading provides a preload by changing the groove pitch of the nut without using a spacer.

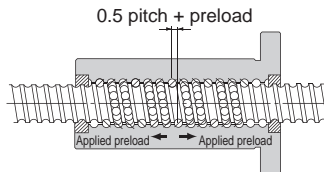

Model SBN-V



Models BIF-V and BIF



Model DIK



Model EPB



Model DIR



Model SBK

Point of Selection

Selecting a Nut

● Constant Pressure Preloading (Model JPF)

With this method, a spring structure is installed almost in the middle of the nut, and it provides a preload by changing the groove pitch in the middle of the nut.

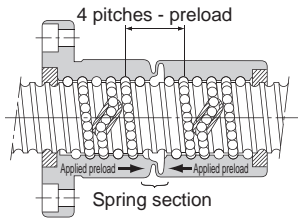

Model JPF

Selecting a Model Number

Calculating the Axial Load

[In Horizontal Mount]

With ordinary conveyance systems, the axial load (F_{a_n}) applied when horizontally reciprocating the work is obtained in the equation below.

$$Fa_1 = \mu \cdot mg + f + m\alpha \quad \dots\dots\dots (17)$$

$$Fa_2 = \mu \cdot mg + f \quad \dots\dots\dots (18)$$

$$Fa_3 = \mu \cdot mg + f - m\alpha \quad \dots\dots\dots (19)$$

$$Fa_4 = -\mu \cdot mg - f - m\alpha \quad \dots\dots\dots (20)$$

$$Fa_5 = -\mu \cdot mg - f \quad \dots\dots\dots (21)$$

$$Fa_6 = -\mu \cdot mg - f + m\alpha \quad \dots\dots\dots (22)$$

$$V_{\max} : \text{Maximum speed} \quad \quad \quad (\text{m/s})$$

$$t_1 : \text{Acceleration time} \quad \quad \quad (\text{m/s})$$

$$\alpha = \frac{V_{\max}}{t_1} : \text{Acceleration} \quad \quad \quad (\text{m/s}^2)$$

$$Fa_1 : \text{Axial load during forward acceleration} \quad (\text{N})$$

$$Fa_2 : \text{Axial load during forward uniform motion} \quad (\text{N})$$

$$Fa_3 : \text{Axial load during forward deceleration} \quad (\text{N})$$

$$Fa_4 : \text{Axial load during backward acceleration} \quad (\text{N})$$

$$Fa_5 : \text{Axial load during uniform backward motion} \quad (\text{N})$$

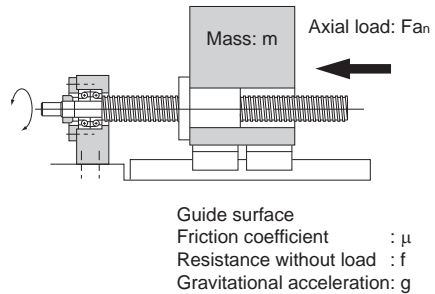

$$Fa_6 : \text{Axial load during backward deceleration} \quad (\text{N})$$

$$m : \text{Transferred mass} \quad \quad \quad (\text{kg})$$

$$\mu : \text{Frictional coefficient of the guide surface} \quad (-)$$

$$f : \text{Guide surface resistance (without load)} \quad (\text{N})$$

[In Vertical Mount]

With ordinary conveyance systems, the axial load (F_{a_n}) applied when vertically reciprocating the work is obtained in the equation below.

$$Fa_1 = mg + f + m\alpha \quad \dots\dots\dots (23)$$

$$Fa_2 = mg + f \quad \dots\dots\dots (24)$$

$$Fa_3 = mg + f - m\alpha \quad \dots\dots\dots (25)$$

$$Fa_4 = mg - f - m\alpha \quad \dots\dots\dots (26)$$

$$Fa_5 = mg - f \quad \dots\dots\dots (27)$$

$$Fa_6 = mg - f + m\alpha \quad \dots\dots\dots (28)$$

$$V_{\max} : \text{Maximum speed} \quad \quad \quad (\text{m/s})$$

$$t_1 : \text{Acceleration time} \quad \quad \quad (\text{m/s})$$

$$\alpha = \frac{V_{\max}}{t_1} : \text{Acceleration} \quad \quad \quad (\text{m/s}^2)$$

$$Fa_1 : \text{Axial load during upward acceleration} \quad (\text{N})$$

$$Fa_2 : \text{Axial load during uniform upward motion} \quad (\text{N})$$

$$Fa_3 : \text{Axial load during upward deceleration} \quad (\text{N})$$

$$Fa_4 : \text{Axial load during downward acceleration} \quad (\text{N})$$

$$Fa_5 : \text{Axial load during uniform downward motion} \quad (\text{N})$$

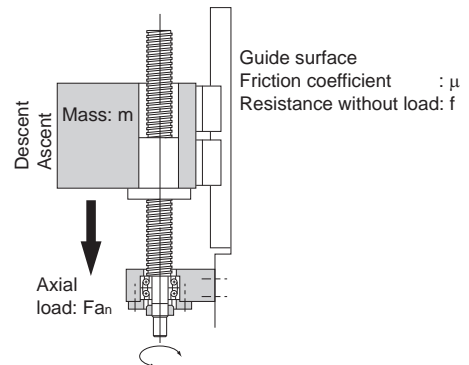

$$Fa_6 : \text{Axial load during downward deceleration} \quad (\text{N})$$

$$m : \text{Transferred mass} \quad \quad \quad (\text{kg})$$

$$f : \text{Guide surface resistance (without load)} \quad (\text{N})$$

Static Safety Factor

The basic static load rating (C_{0a}) generally equals to the permissible axial load of a Ball Screw. Depending on the conditions, it is necessary to take into account the following static safety factor against the calculated load. When the Ball Screw is stationary or in motion, unexpected external force may be applied through an inertia caused by the impact or the start and stop.

$$F_{a_{\max}} = \frac{C_{0a}}{f_s} \dots\dots\dots(29)$$

$F_{a_{\max}}$: Allowable Axial Load (kN)
 C_{0a} : Basic static load rating (kN)
 f_s : Static safety factor (see Table1)

Table1 Static Safety Factor (f_s)

Machine using the LM system	Load conditions	Lower limit of f_s
General industrial machinery	Without vibration or impact	1.0 to 3.5
	With vibration or impact	2.0 to 5.0
Machine tool	Without vibration or impact	1.0 to 4.0
	With vibration or impact	2.5 to 7.0

*The basic static load rating (C_{0a}) is a static load with a constant direction and magnitude whereby the sum of the permanent deformation of the rolling element and that of the raceway on the contact area under the maximum stress is 0.0001 times the rolling element diameter. With the Ball Screw, it is defined as the axial load. (Specific values of each Ball Screw model are indicated in the specification tables for the corresponding model number.)

[Permissible Load Safety Margin (Models HBN and SBKH)]

High load Ball Screw model HBN and high-load high-speed Ball Screw model SBKH, in comparison to previous Ball Screws, are designed to achieve longer service lives under high load conditions, and for axial load it is necessary to consider the permissible load F_p .

Permissible load F_p indicates the maxim axial load that the high load Ball Screw can receive, and this range should not be exceeded.

$$\frac{F_p}{F_a} > 1 \dots\dots\dots(30)$$

F_p : Permissible Axial Load (kN)
 F_a : Applied Axial Load (kN)

Studying the Service Life

[Service Life of the Ball Screw]

The Ball Screw in motion under an external load receives repeated stress on its raceways and balls. When the stress reaches the limit, the raceways break from fatigue and their surfaces flakes like scales. This phenomenon is called flaking. The service life of the Ball Screw is the total number of revolutions until the first flaking occurs on any of the raceways or the balls as a result of rolling fatigue of the material.

The service life of the Ball Screw varies from unit to unit even if they are manufactured in the same process and used in the same operating conditions. For this reason, when determining the service life of a Ball Screw unit, the nominal life as defined below is used as a guideline.

The nominal life is the total number of revolutions that 90% of identical Ball Screw units in a group achieve without developing flaking (scale-like pieces of a metal surface) after they independently operate in the same conditions.

[Calculating the Rated Life]

The service life of the Ball Screw is calculated from the equation (31) below using the basic dynamic load rating (Ca) and the applied axial load.

● Nominal Life (Total Number of Revolutions)

$$L = \left(\frac{C_a}{f_w \cdot F_a} \right)^3 \times 10^6 \quad \dots\dots\dots(31)$$

- L : Nominal life (total number of revolutions) (rev)
 Ca : Basic dynamic load rating (N)
 Fa : Applied axial load (N)
 fw : Load factor (see Table2)

Table2 Load Factor (fw)

Vibrations/impact	Speed(V)	fw
Faint	Very low $V \leq 0.25\text{m/s}$	1 to 1.2
Weak	Slow $0.25 < V \leq 1\text{m/s}$	1.2 to 1.5
Medium	Medium $1 < V \leq 2\text{m/s}$	1.5 to 2
Strong	High $V > 2\text{m/s}$	2 to 3.5

*The basic dynamic load rating (Ca) is used in calculations of service life when the ball screw is under an axial load. The basic dynamic load rating is defined as a load rating based on the movement of a set of identical ball screws with a rated life (L) of 10^6 revolutions, using a load applied in the axial direction that does not vary in either mass or direction. (The basic dynamic load ratings (Ca) for each model number are indicated in the specification tables.)

*The rated service life is estimated by calculating the load on the premise that the product is set up in ideal mounting conditions with the assurance of good lubrication. The service life can be affected by the precision of the mounting materials used and any distortion.

● Service Life Time

If the revolutions per minute is determined, the service life time can be calculated from the equation (32) below using the nominal life (L).

$$L_h = \frac{L}{60 \times N} = \frac{L \times Ph}{2 \times 60 \times n \times \ell_s} \dots\dots\dots(32)$$

L_h	: Service life time	(h)
N	: Revolutions per minute	(min^{-1})
n	: Number of reciprocations per minute	(min^{-1})
Ph	: Ball Screw lead	(mm)
ℓ_s	: Stroke length	(mm)

● Service Life in Travel Distance

The service life in travel distance can be calculated from the equation (33) below using the nominal life (L) and the Ball Screw lead.

$$L_s = \frac{L \times Ph}{10^6} \dots\dots\dots(33)$$

L_s	: Service Life in Travel Distance	(km)
Ph	: Ball Screw lead	(mm)

● Applied Load and Service Life with a Preload Taken into Account

If the Ball Screw is used under a preload (medium preload), it is necessary to consider the applied preload in calculating the service life since the ball screw nut already receives an internal load. For details on applied preload for a specific model number, contact THK.

● Average Axial Load

If an axial load acting on the Ball Screw is present, it is necessary to calculate the service life by determining the average axial load.

The average axial load (F_m) is a constant load that equals to the service life in fluctuating the load conditions.

If the load changes in steps, the average axial load can be obtained from the equation below.

$$F_m = \sqrt[3]{\frac{1}{\ell} (Fa_1^3 \ell_1 + Fa_2^3 \ell_2 + \dots + Fa_n^3 \ell_n)} \dots\dots\dots(34)$$

F_m	: Average Axial Load	(N)
Fa_n	: Varying load	(N)
ℓ_n	: Distance traveled under load (F_n)	
ℓ	: Total travel distance	

To determine the average axial load using a rotational speed and time, instead of a distance, calculate the average axial load by determining the distance in the equation below.

$$l = l_1 + l_2 + \dots + l_n$$

$$l_1 = N_1 \cdot t_1$$

$$l_2 = N_2 \cdot t_2$$

$$l_n = N_n \cdot t_n$$

N: Rotational speed

t: Time

■When the Applied Load Sign Changes

If the sign (positive or negative) used for variable load is always the same, there are no problems with formula (34). However, if the variable load sign changes depending on the type of operation, calculate the average axial load for either positive or negative load, allowing for the load direction. (If the average axial load for positive load is calculated, the negative load is taken to be zero.) The larger of the two average axial loads is taken as the average axial load when the service life is calculated.

Example: Calculate the average axial load with the following load conditions.

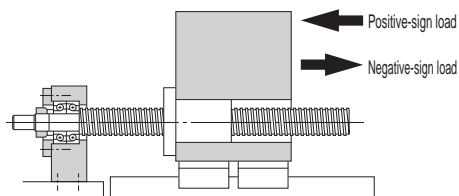

Operation No.	Varying load F_{a_i} (N)	Travel distance l_n (mm)
No.1	10	10
No.2	50	50
No.3	-40	10
No.4	-10	70

*The subscripts of the fluctuating load symbol and the travel distance symbol indicate operation numbers.

● Average axial load of positive-sign load

*To calculate the average axial load of the positive-sign load, assume F_{a_3} and F_{a_4} to be zero.

$$F_{m1} = \sqrt[3]{\frac{F_{a1}^3 \times l_1 + F_{a2}^3 \times l_2}{l_1 + l_2 + l_3 + l_4}} = 35.5\text{N}$$

● Average axial load of negative-sign load

*To calculate the average axial load of the negative-sign load, assume F_{a_1} and F_{a_2} to be zero.

$$F_{m2} = \sqrt[3]{\frac{|F_{a3}|^3 \times l_3 + |F_{a4}|^3 \times l_4}{l_1 + l_2 + l_3 + l_4}} = 17.2\text{N}$$

Accordingly, the average axial load of the positive-sign load (F_{m1}) is adopted as the average axial load (F_m) for calculating the service life.

Studying the Rigidity

To increase the positioning accuracy of feed screws in NC machine tools or the precision machines, or to reduce the displacement caused by the cutting force, it is necessary to design the rigidity of the components in a well-balanced manner.

Axial Rigidity of the Feed Screw System

When the axial rigidity of a feed screw system is K , the elastic displacement in the axial direction can be obtained using the equation (35) below.

$$\delta = \frac{Fa}{K} \dots\dots\dots(35)$$

- δ : Elastic displacement of a feed screw system in the axial direction (μm)
 Fa : Applied axial load (N)

The axial rigidity (K) of the feed screw system is obtained using the equation (36) below.

$$\frac{1}{K} = \frac{1}{K_s} + \frac{1}{K_n} + \frac{1}{K_b} + \frac{1}{K_h} \dots\dots\dots(36)$$

- K : Axial Rigidity of the Feed Screw System ($\text{N}/\mu\text{m}$)
 K_s : Axial rigidity of the screw shaft ($\text{N}/\mu\text{m}$)
 K_n : Axial rigidity of the nut ($\text{N}/\mu\text{m}$)
 K_b : Axial rigidity of the support bearing ($\text{N}/\mu\text{m}$)
 K_h : Rigidity of the nut bracket and the support bearing bracket ($\text{N}/\mu\text{m}$)

[Axial rigidity of the screw shaft]

The axial rigidity of a screw shaft varies depending on the method for mounting the shaft.

● For Fixed-Supported (or -Free) Configuration

$$K_s = \frac{A \cdot E}{1000 \cdot L} \dots\dots\dots(37)$$

- A : Screw shaft cross-sectional area (mm^2)

$$A = \frac{\pi}{4} d_1^2$$

- d_1 : Screw-shaft thread minor diameter (mm)
 E : Young's modulus ($2.06 \times 10^5 \text{ N}/\text{mm}^2$)
 L : Distance between two mounting surfaces (mm)

Fig.7 on **B15-52** shows an axial rigidity diagram for the screw shaft.

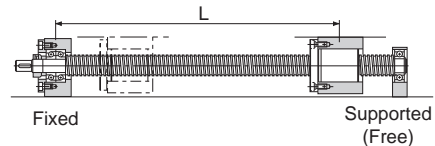

● For Fixed-Fixed Configuration

$$K_s = \frac{A \cdot E \cdot L}{1000 \cdot a \cdot b} \dots\dots\dots(38)$$

K_s becomes the lowest and the elastic displacement in the axial direction is the greatest at the position of $a = b = \frac{L}{2}$.

$$K_s = \frac{4A \cdot E}{1000L}$$

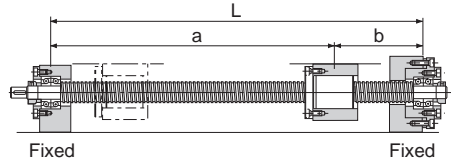

Fig.8 on **B15-53** shows an axial rigidity diagram of the screw shaft in this configuration.

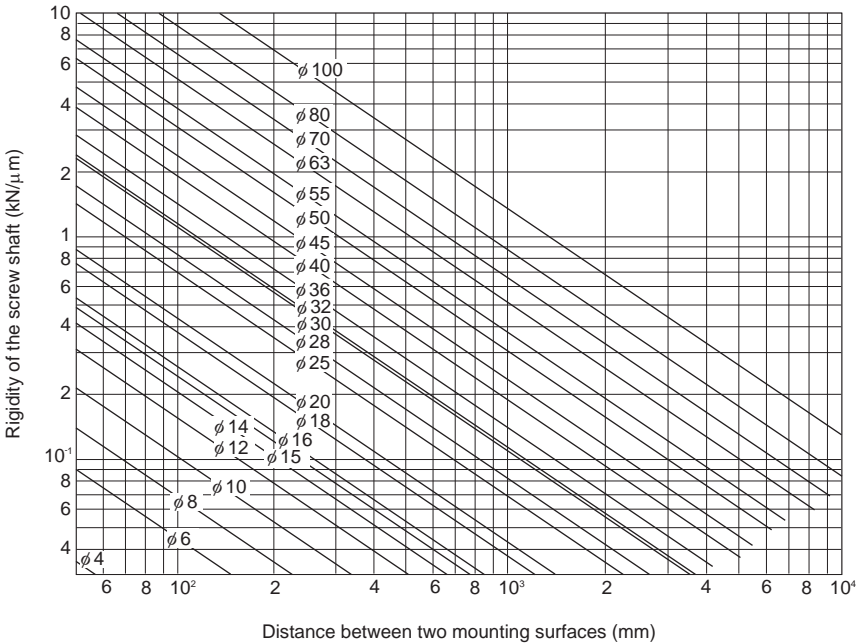

Fig.7 Axial Rigidity of the Screw Shaft (Fixed-Free, Fixed-Supported)

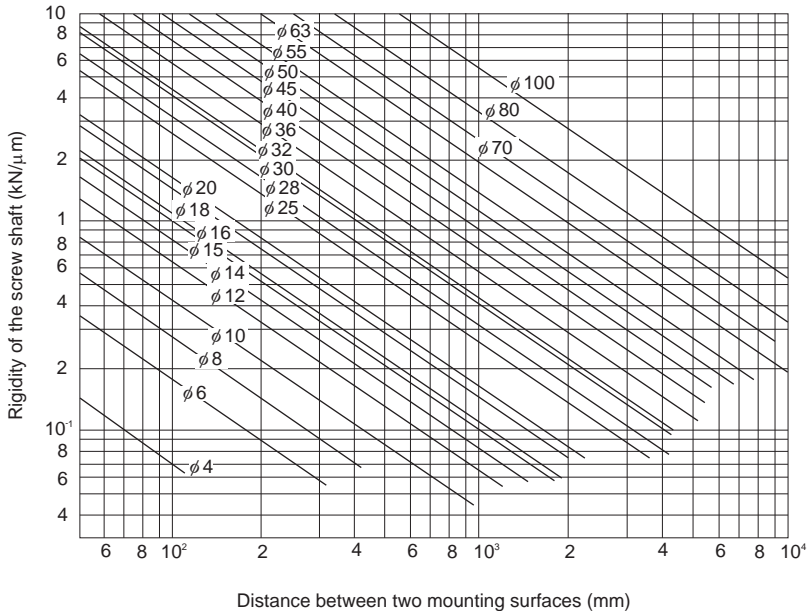

Fig.8 Axial Rigidity of the Screw Shaft (Fixed-Fixed)

[Axial rigidity of the nut]

The axial rigidity of the nut varies widely with preloads.

● No Preload Type

The logical rigidity in the axial direction when an axial load accounting for 30% of the basic dynamic load rating (C_a) is applied is indicated in the specification tables of the corresponding model number. This value does not include the rigidity of the components related to the nut-mounting bracket. In general, set the rigidity at roughly 80% of the value in the table.

The rigidity when the applied axial load is not 30% of the basic dynamic load rating (C_a) is calculated using the equation (39) below.

$$K_N = K \left(\frac{F_a}{0.3C_a} \right)^{\frac{1}{3}} \times 0.8 \quad \dots\dots(39)$$

K_N : Axial rigidity of the nut (N/μm)

K : Rigidity value in the specification tables (N/μm)

F_a : Applied axial load (N)

C_a : Basic dynamic load rating (N)

● Preload Type

The logical rigidity in the axial direction when an axial load accounting for 10% of the basic dynamic load rating (Ca) is applied is indicated in the dimensional table of the corresponding model number. This value does not include the rigidity of the components related to the nut-mounting bracket. In general, generally set the rigidity at roughly 80% of the value in the table.

The rigidity when the applied preload is not 10% of the basic dynamic load rating (Ca) is calculated using the equation (40) below.

$$K_N = K \left(\frac{Fa_0}{0.1Ca} \right)^{\frac{1}{3}} \times 0.8 \quad \dots\dots\dots(40)$$

K_N : Axial rigidity of the nut (N/μm)

K : Rigidity value in the specification tables (N/μm)

Fa_0 : Applied preload (N)

Ca : Basic dynamic load rating (N)

[Axial rigidity of the support bearing]

The rigidity of the Ball Screw support bearing varies depending on the support bearing used.

The calculation of the rigidity with a representative angular contact ball bearing is shown in the equation (41) below.

$$K_B \doteq \frac{3Fa_0}{\delta a_0} \quad \dots\dots\dots(41)$$

K_b : Axial rigidity of the support bearing (N/μm)

Fa_0 : Applied preload of the support bearing (N)

δa_0 : Axial displacements (μm)

$$\delta a_0 = \frac{0.45}{\sin\alpha} \left(\frac{Q^2}{Da} \right)^{\frac{1}{3}}$$

$$Q = \frac{Fa_0}{Z\sin\alpha}$$

Q : Axial load (N)

Da : Ball diameter of the support bearing (mm)

α : Initial contact angle of the support bearing (°)

Z : Number of balls

For details of a specific support bearing, contact its manufacturer.

[Axial Rigidity of the Nut Bracket and the Support Bearing Bracket]

Take this factor into consideration when designing your machine. Set the rigidity as high as possible.

Studying the Positioning Accuracy

Causes of Error in the Positioning Accuracy

The causes of error in the positioning accuracy include the lead angle accuracy, the axial clearance and the axial rigidity of the feed screw system. Other important factors include the thermal displacement from heat and the orientation change of the guide system during traveling.

Studying the Lead Angle Accuracy

It is necessary to select the correct accuracy grade of the Ball Screw that satisfies the required positioning accuracy from the Ball Screw accuracies (Table1 on [B15-20](#)). Table3 on [B15-56](#) shows examples of selecting the accuracy grades by the application.

Studying the Axial Clearance

The axial clearance is not a factor of positioning accuracy in single-directional feed. However, it will cause a backlash when the feed direction is inversed or the axial load is inversed. Select an axial clearance that meets the required backlash from Table10 and Table13 on [B15-27](#).

Table3 Examples of Selecting Accuracy Grades by Application

Applications		Shaft	Accuracy grades							
			C0	C1	C2	C3	C5	C7	C8	C10
NC machine tools	Lathe	X		●	●	●	●			
		Z				●	●			
	Machining center	XY			●	●	●			
		Z			●	●	●			
	Drilling machine	XY				●	●			
		Z					●	●		
	Jig borer	XY	●	●						
		Z	●	●						
	Surface grinder	X				●	●			
		Y		●	●	●	●			
		Z		●	●	●	●			
	Cylindrical grinder	X	●	●	●					
		Z		●	●	●				
	Electric discharge machine	XY	●	●	●					
		Z		●	●	●	●			
	Electric discharge machine	XY	●	●	●					
		Z	●	●	●	●				
	Wire cutting machine	UV		●	●	●				
		XY				●	●	●		
	Laser beam machine	X				●	●	●		
Z					●	●	●			
Woodworking machine						●	●	●	●	
General-purpose machine; dedicated machine					●	●	●	●	●	
Industrial robot	Cartesian coordinate	Assembly				●	●	●	●	
		Other					●	●	●	
	Vertical articulated type	Assembly					●	●	●	
		Other						●	●	
Cylindrical coordinate					●	●	●			
Semiconductor manufacturing machine	Photolithography machine		●	●						
	Chemical treatment machine				●	●	●	●	●	
	Wire bonding machine			●	●					
	Prober		●	●	●	●				
	Printed circuit board drilling machine			●	●	●	●	●		
	Electronic component inserter				●	●	●	●		
3D measuring instrument		●	●	●						
Image processing machine		●	●	●						
Injection molding machine							●	●	●	
Office equipment						●	●	●	●	

Studying the Axial Clearance of the Feed Screw System

Of the axial rigidities of the feed screw system, the axial rigidity of the screw shaft fluctuates according to the stroke position. When the axial rigidity is large, such change in the axial rigidity of the screw shaft will affect the positioning accuracy. Therefore, it is necessary to take into account the rigidity of the feed screw system (**B15-51** to **B15-54**).

Example of considering the rigidity of a feed screw system

Example: Positioning error due to the axial rigidity of the feed screw system during a vertical transfer

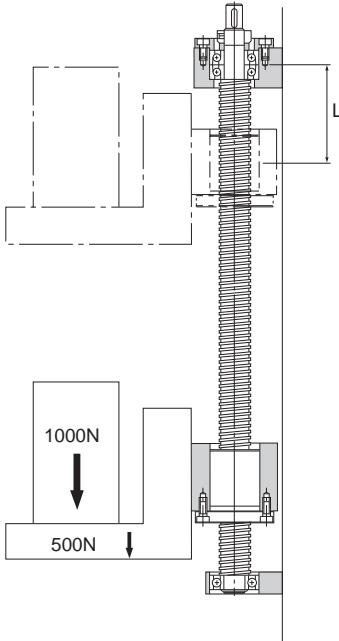

[Conditions]

Transferred weight: 1,000 N; table weight: 500 N

Ball Screw used: model BNF2512-2.5 (screw-shaft thread minor diameter $d_1 = 21.9$ mm)

Stroke length: 600 mm ($L=100$ mm to 700 mm)

Screw shaft mounting type: fixed-supported

[Consideration]

The difference in axial rigidity between $L = 100$ mm and $L = 700$ mm applied only to the axial rigidity of the screw shaft.

Therefore, positioning error due to the axial rigidity of the feed screw system equals to the difference in the axial displacement of the screw shaft between $L = 100$ mm and $L = 700$ mm.

[Axial Rigidity of the Screw Shaft (see B15-51 and B15-52)]

$$K_s = \frac{A \cdot E}{1000L} = \frac{376.5 \times 2.06 \times 10^5}{1000 \times L} = \frac{77.6 \times 10^3}{L}$$

$$A = \frac{\pi}{4} d_1^2 = \frac{\pi}{4} \times 21.9^2 = 376.5 \text{ mm}^2$$

$$E = 2.06 \times 10^5 \text{ N/mm}^2$$

(1) When $L = 100 \text{ mm}$

$$K_{s1} = \frac{77.6 \times 10^3}{100} = 776 \text{ N/}\mu\text{m}$$

(2) When $L = 700 \text{ mm}$

$$K_{s2} = \frac{77.6 \times 10^3}{700} = 111 \text{ N/}\mu\text{m}$$

[Axial Displacement due to Axial Rigidity of the Screw Shaft]

(1) When $L = 100 \text{ mm}$

$$\delta_1 = \frac{Fa}{K_{s1}} = \frac{1000+500}{776} = 1.9 \mu\text{m}$$

(2) When $L = 700 \text{ mm}$

$$\delta_2 = \frac{Fa}{K_{s2}} = \frac{1000+500}{111} = 13.5 \mu\text{m}$$

[Positioning Error due to Axial Rigidity of the Feed Screw System]

$$\begin{aligned} \text{Positioning accuracy} &= \delta_1 - \delta_2 = 1.9 - 13.5 \\ &= -11.6 \mu\text{m} \end{aligned}$$

Therefore, the positioning error due to the axial rigidity of the feed screw system is $11.6 \mu\text{m}$.

Studying the Thermal Displacement through Heat Generation

If the temperature of the screw shaft increases during operation, the screw shaft is elongated due to heat thereby to lower the positioning accuracy. The expansion and contraction of the screw shaft is calculated using the equation (42) below.

$$\Delta l = \rho \times \Delta t \times \ell \dots\dots\dots(42)$$

- Δl : Axial expansion/contraction of the screw shaft (mm)
 ρ : Thermal expansion coefficient ($12 \times 10^{-6}/^{\circ}\text{C}$)
 Δt : Temperature change in the screw shaft ($^{\circ}\text{C}$)
 ℓ : Effective thread length (mm)

Thus, if the temperature of the screw shaft increases by 1°C , the screw shaft is elongated by $12 \mu\text{m}$ per meter. Therefore, as the Ball Screw travels faster, the more heat is generated. So, as the temperature increases, the positioning accuracy lowers. Accordingly, if high accuracy is required, it is necessary to take measures to cope with the temperature increase.

[Measures to Cope with the Temperature Rise]

● Minimize the Heat Generation

- Minimize the preloads on the Ball Screw and the support bearing.
- Increase the Ball Screw lead and reduce the rotational speed.
- Select a correct lubricant. (See Accessories for Lubrication on **A24-2**.)
- Cool the circumference of the screw shaft with a lubricant or air.

● Avoid Effect of Temperature Rise through Heat Generation

- Set a negative target value for the reference travel distance of the Ball Screw.
 Generally, set a negative target value for the reference travel distance assuming a temperature increase of 2°C to 5°C by heat.
 (-0.02mm to -0.06mm/m)
- Preload the shaft screw with tension. (See Fig.3 of the structure on **B15-37**.)

Studying the Orientation Change during Traveling

The lead angle accuracy of the Ball Screw equals the positioning accuracy of the shaft center of the Ball Screw. Normally, the point where the highest positioning accuracy is required changes according to the ball screw center and the vertical or horizontal direction. Therefore, the orientation change during traveling affects the positioning accuracy.

The largest factor of orientation change affecting the positioning accuracy is pitching if the change occurs in the ball screw center and the vertical direction, and yawing if the change occurs in the horizontal direction.

Accordingly, it is necessary to study the orientation change (accuracy in pitching, yawing, etc.) during the traveling on the basis of the distance from the ball screw center to the location where positioning accuracy is required.

Positioning error due to pitching and yawing is obtained using the equation (43) below.

$$A = \ell \times \sin\theta \quad \dots\dots(43)$$

A : Positioning accuracy due to pitching (or yawing) (mm)

ℓ : Vertical (or horizontal) distance from the ball screw center (mm) (see Fig.9)

θ : Pitching (or yawing) ($^{\circ}$)

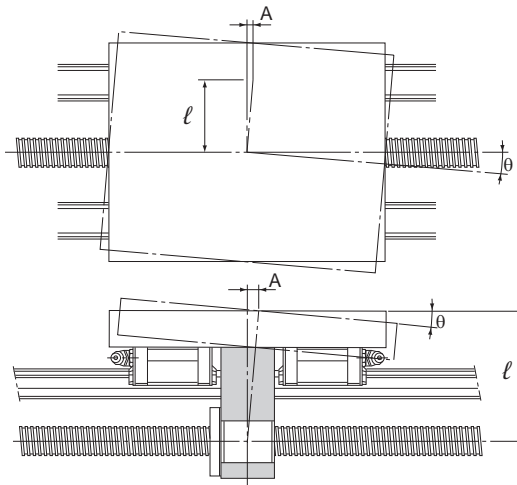

Fig.9

Studying the Rotational Torque

The rotational torque required to convert rotational motion of the Ball Screw into straight motion is obtained using the equation (44) below.

[During Uniform Motion]

$$(T_1 + T_2 + T_4) \cdot A \quad \dots\dots(44)$$

- T_1 : Rotation torque required during uniform motion (N-mm)
 T_1 : Friction torque due to an external load (N-mm)
 T_2 : Preload torque of the Ball Screw (N-mm)
 T_4 : Other torque (N-mm)
 (frictional torque of the support bearing and oil seal)
 A : Reduction ratio

[During Acceleration]

$$T_K = T_t + T_3 \quad \dots\dots(45)$$

- T_K : Rotation torque required during acceleration (N-mm)
 T_3 : Torque required for acceleration (N-mm)

[During Deceleration]

$$T_g = T_t - T_3 \quad \dots\dots(46)$$

- T_g : Rotational torque required for deceleration (N-mm)

Frictional Torque Due to an External Load

Of the turning forces required for the Ball Screw, the rotational torque needed for an external load (guide surface resistance or external force) is obtained using the equation (47) below.

$$T_1 = \frac{F_a \cdot Ph}{2\pi \cdot \eta} \quad \dots\dots(47)$$

- T_1 : Friction torque due to an external load (N-mm)
 F_a : Applied load (N)
 Ph : Ball Screw lead (mm)
 η : Ball Screw efficiency (0.9 to 0.95)

Torque Due to a Preload on the Ball Screw

For a preload on the Ball Screw, see "Preload Torque" on **B15-30**.

Torque Required for Acceleration

$$T_3 = J \times \omega' \times 10^3 \dots\dots(48)$$

T_3 : Torque required for acceleration (N-mm)

J : Inertial moment ($\text{kg}\cdot\text{m}^2$)

ω' : Angular acceleration (rad/s^2)

$$J = m \left(\frac{\text{Ph}}{2\pi} \right)^2 \cdot A^2 \cdot 10^{-6} + J_s \cdot A^2 + J_A \cdot A^2 + J_B$$

m : Transferred mass (kg)

Ph : Ball Screw lead (mm)

J_s : Inertial moment of the screw shaft ($\text{kg}\cdot\text{m}^2$)

(indicated in the specification tables of the respective model number)

A : Reduction ratio

J_A : Inertial moment of gears, etc. attached to the screw shaft side ($\text{kg}\cdot\text{m}^2$)

J_B : Inertial moment of gears, etc. attached to the motor side ($\text{kg}\cdot\text{m}^2$)

$$\omega' = \frac{2\pi \cdot \text{Nm}}{60t}$$

Nm : Motor revolutions per minute (min^{-1})

t : Acceleration time (s)

[Ref.] Inertial moment of a round object

$$J = \frac{m \cdot D^2}{8 \cdot 10^6}$$

J : Inertial moment ($\text{kg}\cdot\text{m}^2$)

m : Mass of a round object (kg)

D : Screw shaft outer diameter (mm)

Investigating the Terminal Strength of Ball Screw Shafts

When torque is conveyed through the screw shaft in a ball screw, the strength of the screw shaft must be taken into consideration since it experiences both torsion load and bending load.

[Screw shaft under torsion]

When torsion load is applied to the end of a ball screw shaft, use equation (49) to obtain the end diameter of the screw shaft.

$$T = \tau_a \cdot Z_P \quad \text{and} \quad Z_P = \frac{T}{\tau_a} \quad \dots\dots(49)$$

T : Maximum torsion moment (N-mm)

τ_a : Permissible torsion stress of the screw Shaft (49 N/mm²)

Z_P : Section modulus (mm³)

$$Z_P = \frac{\pi \cdot d^3}{16}$$

T: Torsion moment

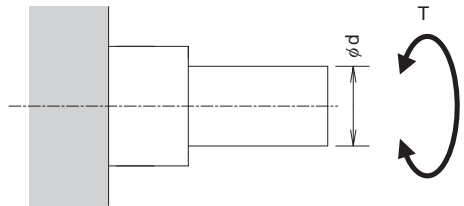

[Screw shaft under bending]

When bending load is applied to the end of a ball screw shaft, use equation (50) to obtain the end diameter of the screw shaft.

$$M = \sigma \cdot Z \quad \text{and} \quad Z = \frac{M}{\sigma} \quad \dots\dots(50)$$

M : Maximum bending moment (N-mm)

σ : Permissible bending stress of the screw shaft (98 N/mm²)

Z : Section Modulus (mm³)

$$Z = \frac{\pi \cdot d^3}{32}$$

M: Bending moment

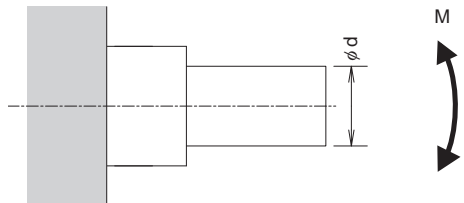

[If the shaft experiences both torsion and bending]

When torsion load and bending load are both applied simultaneously to the end of a ball screw shaft, calculate the diameter of the screw shaft separately for each, taking into consideration the corresponding bending moment (M_e) and the corresponding torsion moment (T_e). Then calculate the thickness of the screw shaft and use the largest of the values.

Equivalent bending moment

$$M_e = \frac{M + \sqrt{M^2 + T^2}}{2} = \frac{M}{2} \left\{ 1 + \sqrt{1 + \left(\frac{T}{M}\right)^2} \right\}$$

$$M_e = \sigma \cdot Z$$

Equivalent torsion moment

$$T_e = \sqrt{M^2 + T^2} = M \cdot \sqrt{1 + \left(\frac{T}{M}\right)^2}$$

$$T_e = \tau_a \cdot Z_P$$

Studying the Driving Motor

When selecting a driving motor required to rotate the Ball Screw, normally take into account the rotational speed, rotational torque and minimum feed amount.

When Using a Servomotor

[Rotational Speed]

The rotation speed required for the motor is obtained using the equation (51) based on the feed speed, Ball Screw lead and reduction ratio.

$$N_M = \frac{V \times 1000 \times 60}{Ph} \times \frac{1}{A} \dots\dots(51)$$

- N_M : Required rotation speed of the motor (min^{-1})
 V : Feeding speed (m/s)
 Ph : Ball Screw lead (mm)
 A : Reduction ratio

The rated rotational speed of the motor must be equal to or above the calculated value (N_M) above.

$$N_M \leq N_R$$

- N_R : The rated rotation speed of the motor (min^{-1})

[Required Resolution]

Resolutions required for the encoder and the driver are obtained using the equation (52) based on the minimum feed amount, Ball Screw lead and reduction ratio.

$$B = \frac{Ph \cdot A}{S} \dots\dots(52)$$

- B : Resolution required for the encoder and the driver (p/rev)
 Ph : Ball Screw lead (mm)
 A : Reduction ratio
 S : Minimum feed amount (mm)

[Motor Torque]

The torque required for the motor differs between uniform motion, acceleration and deceleration. To calculate the rotational torque, see “Studying the Rotational Torque” on **B15-61**.

a. Maximum torque

The maximum torque required for the motor must be equal to or below the maximum peak torque of the motor.

$$T_{\max} \leq T_{p\max}$$

T_{\max} : Maximum torque acting on the motor

$T_{p\max}$: Maximum peak torque of the motor

b. Effective torque value

The effective value of the torque required for the motor must be calculated. The effective value of the torque is obtained using the equation (53).

$$T_{\text{rms}} = \sqrt{\frac{T_1^2 \times t_1 + T_2^2 \times t_2 + T_3^2 \times t_3}{t}} \dots\dots\dots(53)$$

T_{rms} : Effective torque value (N-mm)

T_n : Fluctuating torque (N-mm)

t_n : Time during which the torque T_n is applied (s)

t : Cycle time (s)

$$(t=t_1+t_2+t_3)$$

The calculated effective value of the torque must be equal to or below the rated torque of the motor.

$$T_{\text{rms}} \leq T_R$$

T_R : Rated torque of the motor (N-mm)

[Inertial Moment]

The inertial moment required for the motor is obtained using the equation (54).

$$J_M = \frac{J}{C} \dots\dots\dots(54)$$

J_M : Inertial moment required for the motor ($\text{kg}\cdot\text{m}^2$)

C : Factor determined by the motor and the driver

(It is normally between 3 to 10. However, it varies depending on the motor and the driver. Check the specific value in the catalog by the motor manufacturer.)

The inertial moment of the motor must be equal to or above the calculated J_M value.

When Using a Stepping Motor (Pulse Motor)

[Minimal Feed Amount(per Step)]

The step angle required for the motor and the driver is obtained using the equation (55) based on the minimum feed amount, Ball Screw lead and reduction ratio.

$$E = \frac{360S}{Ph \cdot A} \dots\dots(55)$$

E : Step angle required for the motor and the driver (°)

S : Minimum feed amount (mm)
(per step)

Ph : Ball Screw lead (mm)

A : Reduction ratio

[Pulse Speed and Motor Torque]

a. Pulse speed

The pulse speed is obtained using the equation (56) based on the feed speed and the minimum feed amount.

$$f = \frac{V \times 1000}{S} \dots\dots(56)$$

f : Pulse speed (Hz)

V : Feeding speed (m/s)

S : Minimum feed amount (mm)

b. Torque required for the motor

The torque required for the motor differs between the uniform motion, the acceleration and the deceleration. To calculate the rotational torque, see “Studying the Rotational Torque” on **B15-61**.

Thus, the pulse speed required for the motor and the required torque can be calculated in the manner described above.

Although the torque varies depending on the motors, normally the calculated torque should be doubled to ensure safety. Check if the torque can be used in the motor’s speed-torque curve.

Examples of Selecting a Ball Screw

High-speed Transfer Equipment (Horizontal Use)

[Selection Conditions]

Table Mass	$m_1 = 60\text{kg}$	Positioning accuracy repeatability	$\pm 0.1\text{ mm}$
Work Mass	$m_2 = 20\text{kg}$	Minimum feed amount	$s = 0.02\text{mm/pulse}$
Stroke length	$l_s = 1000\text{mm}$	Desired service life time	30000h
Maximum speed	$V_{\text{max}} = 1\text{m/s}$	Driving motor	AC servo motor
Acceleration time	$t_1 = 0.15\text{s}$		Rated rotational speed:
Deceleration time	$t_3 = 0.15\text{s}$		$3,000\text{ min}^{-1}$
Number of reciprocations per minute	$n = 8\text{min}^{-1}$	Inertial moment of the motor	$J_m = 1 \times 10^{-3}\text{ kg}\cdot\text{m}^2$
Backlash	0.15mm	Reduction gear	None (direct coupling) $A=1$
Positioning accuracy	$\pm 0.3\text{ mm}/1000\text{ mm}$ (Perform positioning from the negative direction)	Frictional coefficient of the guide surface	$\mu = 0.003$ (rolling)
		Guide surface resistance	$f = 15\text{ N}$ (without load)

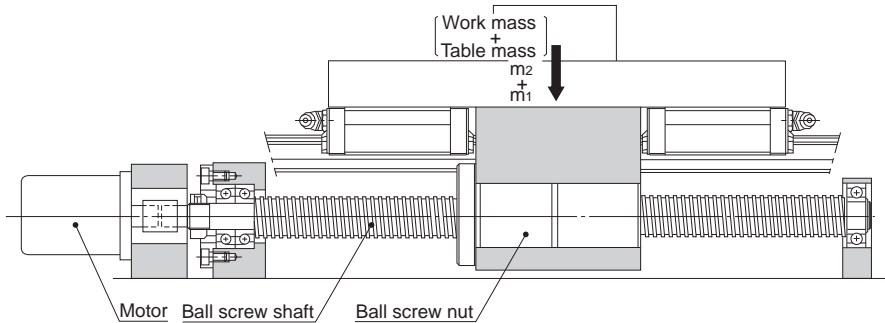

[Selection Items]

- Screw shaft diameter
- Lead
- Nut model No.
- Accuracy
- Axial clearance
- Screw shaft support method
- Driving motor

[Selecting Lead Angle Accuracy and Axial Clearance]

● Selecting Lead Angle Accuracy

To achieve positioning accuracy of ± 0.3 mm/1,000 mm:

$$\frac{\pm 0.3}{1000} = \frac{\pm 0.09}{300}$$

The lead angle accuracy must be ± 0.09 mm/300 mm or higher.

Therefore, select the following as the accuracy grade of the Ball Screw (see Table1 on **B 15-20**).

C7 (travel distance error: ± 0.05 mm/300mm)

Accuracy grade C7 is available for both the Rolled and the Precision Ball Screws. Assume that a Rolled Ball Screw is selected here because it is less costly.

● Selecting Axial Clearance

To satisfy the backlash of 0.15 mm, it is necessary to select a Ball Screw with an axial clearance of 0.15 mm or less.

Therefore, a Rolled Ball Screw model with a screw shaft diameter of 32 mm or less that meets the axial clearance of 0.15 mm or less (see Table13 on **B 15-27**) meets the requirements.

Thus, a Rolled Ball Screw model with a screw shaft diameter of 32 mm or less and an accuracy grade of C7 is selected.

[Selecting a Screw Shaft]

● Assuming the Screw Shaft Length

Assume the overall nut length to be 100 mm and the screw shaft end length to be 100 mm.

Therefore, the overall length is determined as follows based on the stroke length of 1,000 mm.

$$1000 + 200 = 1200 \text{ mm}$$

Thus, the screw shaft length is assumed to be 1,200 mm.

● Selecting a Lead

With the driving motor's rated rotational speed being $3,000 \text{ min}^{-1}$ and the maximum speed 1 m/s, the Ball Screw lead is obtained as follows:

$$\frac{1 \times 1000 \times 60}{3000} = 20 \text{ mm}$$

Therefore, it is necessary to select a type with a lead of 20 mm or longer.

In addition, the Ball Screw and the motor can be mounted in direct coupling without using a reduction gear. The minimum resolution per revolution of an AC servomotor is obtained based on the resolution of the encoder (1,000 p/rev; 1,500 p/rev) provided as a standard accessory for the AC servomotor, as indicated below.

1000 p/rev(without multiplication)

1500 p/rev(without multiplication)

2000 p/rev(doubled)

3000 p/rev(doubled)

4000 p/rev(quadrupled)

6000 p/rev(quadrupled)

To meet the minimum feed amount of 0.02 mm/pulse, which is the selection requirement, the following should apply.

Lead	20mm	—	1000 p/rev
	30mm	—	1500 p/rev
	40mm	—	2000 p/rev
	60mm	—	3000 p/rev
	80mm	—	4000 p/rev

● Selecting a Screw Shaft Diameter

Those Ball Screw models that meet the requirements defined in Section [Selecting Lead Angle Accuracy and Axial Clearance] on **B15-70**: a rolled Ball Screw with a screw shaft diameter of 32 mm or less; and the requirement defined in Section [Selecting a Screw Shaft] on **B15-70**: a lead of 20, 30, 40, 60 or 80 mm (see Table20 on **B15-35**) are as follows.

Shaft diameter	Lead
15mm	— 20mm
15mm	— 30mm
20mm	— 20mm
20mm	— 40mm
30mm	— 60mm

Since the screw shaft length has to be 1,200 mm as indicated in Section [Selecting a Screw Shaft] on **B15-70**, the shaft diameter of 15 mm is insufficient. Therefore, the Ball Screw should have a screw shaft diameter of 20 mm or greater.

Accordingly, there are three combinations of screw shaft diameters and leads that meet the requirements: screw shaft diameter of 20 mm/lead of 20 mm; 20 mm/40 mm; and 30 mm/60 mm.

● Selecting a Screw Shaft Support Method

Since the assumed type has a long stroke length of 1,000 mm and operates at high speed of 1 m/s, select either the fixed-supported or fixed-fixed configuration for the screw shaft support.

However, the fixed-fixed configuration requires a complicated structure, needs high accuracy in the installation.

Accordingly, the fixed-supported configuration is selected as the screw shaft support method.

● Studying the Permissible Axial Load

■ Calculating the Maximum Axial Load

Guide surface resistance	$f=15 \text{ N (without load)}$
Table Mass	$m_1 =60 \text{ kg}$
Work Mass	$m_2 =20 \text{ kg}$
Frictional coefficient of the guide surface	$\mu= 0.003$
Maximum speed	$V_{\max}=1 \text{ m/s}$
Gravitational acceleration	$g = 9.807 \text{ m/s}^2$
Acceleration time	$t_1 = 0.15\text{s}$

Accordingly, the required values are obtained as follows.

Acceleration:

$$\alpha = \frac{V_{\max}}{t_1} = 6.67 \text{ m/s}^2$$

During forward acceleration:

$$Fa_1 = \mu \cdot (m_1 + m_2) g + f + (m_1 + m_2) \cdot \alpha = 550 \text{ N}$$

During forward uniform motion:

$$Fa_2 = \mu \cdot (m_1 + m_2) g + f = 17 \text{ N}$$

During forward deceleration:

$$Fa_3 = \mu \cdot (m_1 + m_2) g + f - (m_1 + m_2) \cdot \alpha = -516 \text{ N}$$

During backward acceleration:

$$Fa_4 = -\mu \cdot (m_1 + m_2) g - f - (m_1 + m_2) \cdot \alpha = -550 \text{ N}$$

During uniform backward motion:

$$Fa_5 = -\mu \cdot (m_1 + m_2) g - f = -17 \text{ N}$$

During backward deceleration:

$$Fa_6 = -\mu \cdot (m_1 + m_2) g - f + (m_1 + m_2) \cdot \alpha = 516 \text{ N}$$

Thus, the maximum axial load applied on the Ball Screw is as follows:

$$Fa_{\max} = Fa_1 = 550 \text{ N}$$

Therefore, if there is no problem with a shaft diameter of 20 mm and a lead of 20 mm (smallest thread minor diameter of 17.5 mm), then the screw shaft diameter of 30 mm should meet the requirements. Thus, the following calculations for the buckling load and the permissible compressive and tensile load of the screw shaft are performed while assuming a screw shaft diameter of 20 mm and a lead of 20 mm.

■ Buckling Load on the Screw Shaft

Factor according to the mounting method

$\eta_2=20$ (see **B15-38**)

Since the mounting method for the section between the nut and the bearing, where buckling is to be considered, is "fixed-fixed: "

Distance between two mounting surfaces

$l_a=1100$ mm (estimate)

Screw-shaft thread minor diameter

$d_i=17.5$ mm

$$P_1 = \eta_2 \cdot \frac{d_i^4}{l_a^2} \times 10^4 = 20 \times \frac{17.5^4}{1100^2} \times 10^4 = 15500 \text{ N}$$

■ Permissible Compressive and Tensile Load of the Screw Shaft

$$P_2 = 116 \times d_i^2 = 116 \times 17.5^2 = 35500 \text{ N}$$

Thus, the buckling load and the permissible compressive and the tensile load of the screw shaft are at least equal to the maximum axial load. Therefore, a Ball Screw that meets these requirements can be used without a problem.

● Studying the Permissible Rotational Speed

■ Maximum Rotational Speed

- Screw shaft diameter: 20 mm; lead: 20 mm

Maximum speed $V_{\max}=1$ m/s

Lead $Ph=20$ mm

$$N_{\max} = \frac{V_{\max} \times 60 \times 10^3}{Ph} = 3000 \text{ min}^{-1}$$

- Screw shaft diameter: 20 mm; lead: 40 mm

Maximum speed $V_{\max}=1$ m/s

Lead $Ph=40$ mm

$$N_{\max} = \frac{V_{\max} \times 60 \times 10^3}{Ph} = 1500 \text{ min}^{-1}$$

- Screw shaft diameter: 30 mm; lead: 60 mm

Maximum speed $V_{\max}=1$ m/s

Lead $Ph=60$ mm

$$N_{\max} = \frac{V_{\max} \times 60 \times 10^3}{Ph} = 1000 \text{ min}^{-1}$$

■ Permissible Rotational Speed Determined by the Dangerous Speed of the Screw Shaft

Factor according to the mounting method

$$\lambda_2 = 15.1 \text{ (see B15-40)}$$

Since the mounting method for the section between the nut and the bearing, where dangerous speed is to be considered, is "fixed-supported: "

Distance between two mounting surfaces

$$\ell_b = 1100 \text{ mm (estimate)}$$

- Screw shaft diameter: 20 mm; lead: 20 mm and 40 mm

Screw-shaft thread minor diameter

$$d_1 = 17.5 \text{ mm}$$

$$N_1 = \lambda_2 \times \frac{d_1}{\ell_b^2} 10^7 = 15.1 \times \frac{17.5}{1100^2} \times 10^7 = 2180 \text{ min}^{-1}$$

- Screw shaft diameter: 30 mm; lead: 60 mm

Screw-shaft thread minor diameter

$$d_1 = 26.4 \text{ mm}$$

$$N_1 = \lambda_2 \times \frac{d_1}{\ell_b^2} 10^7 = 15.1 \times \frac{26.4}{1100^2} \times 10^7 = 3294 \text{ min}^{-1}$$

■ Permissible Rotational Speed Determined by the DN Value

- Screw shaft diameter: 20 mm; lead: 20 mm and 40 mm (large lead Ball Screw)

Ball center-to-center diameter

$$D = 20.75 \text{ mm}$$

$$N_2 = \frac{70000}{D} = \frac{70000}{20.75} = 3370 \text{ min}^{-1}$$

- Screw shaft diameter: 30 mm; lead: 60 mm (large lead Ball Screw)

Ball center-to-center diameter

$$D = 31.25 \text{ mm}$$

$$N_2 = \frac{70000}{D} = \frac{70000}{31.25} = 2240 \text{ min}^{-1}$$

Thus, with a Ball Screw having a screw shaft diameter of 20 mm and a lead of 20 mm, the maximum rotational speed exceeds the dangerous speed.

In contrast, a combination of a screw shaft diameter of 20 mm and a lead of 40 mm, and another of a screw shaft diameter of 30 mm and a lead of 60 mm, meet the dangerous speed and the DN value.

Accordingly, a Ball Screw with a screw shaft diameter of 20 mm and a lead of 40 mm, or with a screw shaft diameter of 30 mm and a lead of 60 mm, is selected.

[Selecting a Nut]

● Selecting a Nut Model Number

Rolled Ball Screw models with a screw shaft diameter of 20 mm and a lead of 40 mm, or with a screw shaft diameter of 30 mm and a lead of 60 mm, are large lead Rolled Ball Screw model WTF variations.

WTF2040-2

(Ca=5.4 kN, C_{0a}=13.6 kN)

WTF2040-3

(Ca=6.6 kN, C_{0a}=17.2 kN)

WTF3060-2

(Ca=11.8 kN, C_{0a}=30.6 kN)

WTF3060-3

(Ca=14.5 kN, C_{0a}=38.9 kN)

● Studying the Permissible Axial Load

Study the permissible axial load of model WTF2040-2 ($C_{0a} = 13.6$ kN).

Assuming that this model is used in high-speed transfer equipment and an impact load is applied during deceleration, set the static safety factor (f_s) at 2.5 (see Table1 on **B15-47**).

$$\frac{C_{0a}}{f_s} = \frac{13.6}{2.5} = 5.44 \text{ kN} = 5440 \text{ N}$$

The obtained permissible axial load is greater than the maximum axial load of 550 N, and therefore, there will be no problem with this model.

■ Calculating the Travel Distance

Maximum speed $V_{\max} = 1$ m/s

Acceleration time $t_1 = 0.15$ s

Deceleration time $t_3 = 0.15$ s

- Travel distance during acceleration

$$l_{1,4} = \frac{V_{\max} \cdot t_1}{2} \times 10^3 = \frac{1 \times 0.15}{2} \times 10^3 = 75 \text{ mm}$$

- Travel distance during uniform motion

$$l_{2,5} = l_s - \frac{V_{\max} \cdot t_1 + V_{\max} \cdot t_3}{2} \times 10^3 = 1000 - \frac{1 \times 0.15 + 1 \times 0.15}{2} \times 10^3 = 850 \text{ mm}$$

- Travel distance during deceleration

$$l_{3,6} = \frac{V_{\max} \cdot t_3}{2} \times 10^3 = \frac{1 \times 0.15}{2} \times 10^3 = 75 \text{ mm}$$

Based on the conditions above, the relationship between the applied axial load and the travel distance is shown in the table below.

Motion	Applied axial load F_{a_i} (N)	Travel distance l_{i_i} (mm)
No.1: During forward acceleration	550	75
No.2: During forward uniform motion	17	850
No.3: During forward deceleration	-516	75
No.4: During backward acceleration	-550	75
No.5: During uniform backward motion	-17	850
No.6: During backward deceleration	516	75

* The subscript (N) indicates a motion number.

Since the load direction (as expressed in positive or negative sign) is reversed with F_{a_3} , F_{a_4} and F_{a_5} , calculate the average axial load in the two directions.

■ Average Axial Load

- Average axial load in the positive direction

Since the load direction varies, calculate the average axial load while assuming $F_{a_{3,4,5}} = 0\text{N}$.

$$F_{m1} = \sqrt[3]{\frac{F_{a1}^3 \times l_1 + F_{a2}^3 \times l_2 + F_{a6}^3 \times l_6}{l_1 + l_2 + l_3 + l_4 + l_5 + l_6}} = 225 \text{ N}$$

- Average axial load in the negative direction

Since the load direction varies, calculate the average axial load while assuming $F_{a_{1,2,6}} = 0\text{N}$.

$$F_{m2} = \sqrt[3]{\frac{|F_{a3}|^3 \times l_3 + |F_{a4}|^3 \times l_4 + |F_{a5}|^3 \times l_5}{l_1 + l_2 + l_3 + l_4 + l_5 + l_6}} = 225 \text{ N}$$

Since $F_{m1} = F_{m2}$, assume the average axial load to be $F_m = F_{m1} = F_{m2} = 225 \text{ N}$.

■ Nominal Life

Load factor	$f_w = 1.5$ (see Table2 on B15-48)
Average load	$F_m = 225 \text{ N}$
Nominal life	L (rev)

$$L = \left(\frac{C_a}{f_w \cdot F_m} \right)^3 \times 10^6$$

Assumed model number	Dynamic load rating $C_a(\text{N})$	Nominal life $L(\text{rev})$
WTF 2040-2	5400	4.1×10^9
WTF 2040-3	6600	7.47×10^9
WTF 3060-2	11800	4.27×10^{10}
WTF 3060-3	14500	7.93×10^{10}

■ Average Revolutions per Minute

Number of reciprocations per minute $n = 8 \text{ min}^{-1}$
 Stroke $l_s = 1000 \text{ mm}$

- Lead: $Ph = 40 \text{ mm}$

$$N_m = \frac{2 \times n \times l_s}{Ph} = \frac{2 \times 8 \times 1000}{40} = 400 \text{ min}^{-1}$$

- Lead: $Ph = 60 \text{ mm}$

$$N_m = \frac{2 \times n \times l_s}{Ph} = \frac{2 \times 8 \times 1000}{60} = 267 \text{ min}^{-1}$$

■ Calculating the Service Life Time on the Basis of the Nominal Life

- WTF2040-2

Nominal life $L = 4.1 \times 10^9 \text{ rev}$
 Average revolutions per minute $N_m = 400 \text{ min}^{-1}$

$$L_h = \frac{L}{60 \times N_m} = \frac{4.1 \times 10^9}{60 \times 400} = 171000 \text{ h}$$

- WTF2040-3

Nominal life $L = 7.47 \times 10^9 \text{ rev}$
 Average revolutions per minute $N_m = 400 \text{ min}^{-1}$

$$L_h = \frac{L}{60 \times N_m} = \frac{7.47 \times 10^9}{60 \times 400} = 311000 \text{ h}$$

- WTF3060-2

Nominal life $L = 4.27 \times 10^{10} \text{ rev}$
 Average revolutions per minute $N_m = 267 \text{ min}^{-1}$

$$L_h = \frac{L}{60 \times N_m} = \frac{4.27 \times 10^{10}}{60 \times 267} = 2670000 \text{ h}$$

- WTF3060-3

Nominal life $L = 7.93 \times 10^{10} \text{ rev}$
 Average revolutions per minute $N_m = 267 \text{ min}^{-1}$

$$L_h = \frac{L}{60 \times N_m} = \frac{7.93 \times 10^{10}}{60 \times 267} = 4950000 \text{ h}$$

■ Calculating the Service Life in Travel Distance on the Basis of the Nominal Life

- WTF2040-2

Nominal life	$L=4.1 \times 10^9$ rev
Lead	$Ph=40$ mm
$L_s = L \times Ph \times 10^{-6} = 164000$ km	
- WTF2040-3

Nominal life	$L=7.47 \times 10^9$ rev
Lead	$Ph=40$ mm
$L_s = L \times Ph \times 10^{-6} = 298800$ km	
- WTF3060-2

Nominal life	$L=4.27 \times 10^{10}$ rev
Lead	$Ph=60$ mm
$L_s = L \times Ph \times 10^{-6} = 2562000$ km	
- WTF3060-3

Nominal life	$L=7.93 \times 10^{10}$ rev
Lead	$Ph=60$ mm
$L_s = L \times Ph \times 10^{-6} = 4758000$ km	

With all the conditions stated above, the following models satisfying the desired service life time of 30,000 hours are selected.

WTF 2040-2

WTF 2040-3

WTF 3060-2

WTF 3060-3

[Studying the Rigidity]

Since the conditions for selection do not include rigidity and this element is not particularly necessary, it is not described here.

[Studying the Positioning Accuracy]**● Studying the Lead Angle Accuracy**

Accuracy grade C7 was selected in Section [Selecting Lead Angle Accuracy and Axial Clearance] on **B15-70**.

C7 (travel distance error: $\pm 0.05\text{mm}/300\text{mm}$)

● Studying the Axial Clearance

Since positioning is performed in a given direction only, axial clearance is not included in the positioning accuracy. As a result, there is no need to study the axial clearance.

WTF2040: axial clearance: 0.1 mm

WTF3060: axial clearance: 0.14 mm

● Studying the Axial Rigidity

Since the load direction does not change, it is unnecessary to study the positioning accuracy on the basis of the axial rigidity.

● Studying the Thermal Displacement through Heat Generation

Assume the temperature rise during operation to be 5°C .

The positioning accuracy based on the temperature rise is obtained as follows:

$$\begin{aligned}\Delta l &= \rho \times \Delta t \times l \\ &= 12 \times 10^{-6} \times 5 \times 1000 \\ &= 0.06 \text{ mm}\end{aligned}$$

● Studying the Orientation Change during Traveling

Since the ball screw center is 150 mm away from the point where the highest accuracy is required, it is necessary to study the orientation change during traveling.

Assume that pitching can be done within ± 10 seconds because of the structure. The positioning error due to the pitching is obtained as follows:

$$\begin{aligned}\Delta a &= l \times \sin \theta \\ &= 150 \times \sin (\pm 10'') \\ &= \pm 0.007 \text{ mm}\end{aligned}$$

Thus, the positioning accuracy (Δp) is obtained as follows:

$$\Delta p = \frac{\pm 0.05 \times 1000}{300} \pm 0.007 + 0.06 = 0.234 \text{ mm}$$

Since models WTF2040-2, WTF2040-3, WTF3060-2 and WTF3060-3 meet the selection requirements throughout the studying process in Section [Selecting Lead Angle Accuracy and Axial Clearance] on **B15-70** to Section [Studying the Positioning Accuracy] on **B15-79**, the most compact model WTF2040-2 is selected.

[Studying the Rotational Torque]

● Friction Torque Due to an External Load

The friction torque is obtained as follows:

$$T_1 = \frac{F_a \cdot Ph}{2\pi \cdot \eta} \cdot A = \frac{17 \times 40}{2 \times \pi \times 0.9} \times 1 = 120 \text{ N} \cdot \text{mm}$$

● Torque Due to a Preload on the Ball Screw

The Ball Screw is not provided with a preload.

● Torque Required for Acceleration

Inertial Moment

Since the inertial moment per unit length of the screw shaft is $1.23 \times 10^{-3} \text{ kg} \cdot \text{cm}^2/\text{mm}$ (see the specification table), the inertial moment of the screw shaft with an overall length of 1200 mm is obtained as follows.

$$J_s = 1.23 \times 10^{-3} \times 1200 = 1.48 \text{ kg} \cdot \text{cm}^2 \\ = 1.48 \times 10^{-4} \text{ kg} \cdot \text{m}^2$$

$$J = (m_1 + m_2) \left(\frac{Ph}{2 \times \pi} \right)^2 \cdot A^2 \times 10^{-6} + J_s \cdot A^2 = (60 + 20) \left(\frac{40}{2 \times \pi} \right)^2 \times 1^2 \times 10^{-6} + 1.48 \times 10^{-4} \times 1^2 \\ = 3.39 \times 10^{-3} \text{ kg} \cdot \text{m}^2$$

Angular acceleration:

$$\omega' = \frac{2\pi \cdot Nm}{60 \cdot t_1} = \frac{2\pi \times 1500}{60 \times 0.15} = 1050 \text{ rad/s}^2$$

Based on the above, the torque required for acceleration is obtained as follows.

$$T_2 = (J + J_m) \times \omega' = (3.39 \times 10^{-3} + 1 \times 10^{-3}) \times 1050 = 4.61 \text{ N} \cdot \text{m} \\ = 4.61 \times 10^3 \text{ N} \cdot \text{mm}$$

Therefore, the required torque is specified as follows.

During acceleration

$$T_k = T_1 + T_2 = 120 + 4.61 \times 10^3 = 4730 \text{ N} \cdot \text{mm}$$

During uniform motion

$$T_i = T_1 = 120 \text{ N} \cdot \text{mm}$$

During deceleration

$$T_g = T_1 - T_2 = 120 - 4.61 \times 10^3 = -4490 \text{ N} \cdot \text{mm}$$

[Studying the Driving Motor]**● Rotational Speed**

Since the Ball Screw lead is selected based on the rated rotational speed of the motor, it is unnecessary to study the rotational speed of the motor.

Maximum working rotational speed : 1500 min⁻¹

Rated rotational speed of the motor: 3000 min⁻¹

● Minimum Feed Amount

As with the rotational speed, the Ball Screw lead is selected based on the encoder normally used for an AC servomotor. Therefore, it is unnecessary to study this factor.

Encoder resolution: 1000 p/rev.

Doubled: 2000 p/rev

● Motor Torque

The torque during acceleration calculated in Section [Studying the Rotational Torque] on **B15-80** is the required maximum torque.

$$T_{\max} = 4730 \text{ N} \cdot \text{mm}$$

Therefore, the instantaneous maximum torque of the AC servomotor needs to be at least 4,730 N-mm.

● Effective Torque Value

The selection requirements and the torque calculated in Section [Studying the Rotational Torque] on **B15-80** can be expressed as follows.

During acceleration:

$$T_k = 4730 \text{ N} \cdot \text{mm}$$

$$t_1 = 0.15 \text{ s}$$

During uniform motion:

$$T_i = 120 \text{ N} \cdot \text{mm}$$

$$t_2 = 0.85 \text{ s}$$

During deceleration:

$$T_g = 4490 \text{ N} \cdot \text{mm}$$

$$t_3 = 0.15 \text{ s}$$

When stationary:

$$T_s = 0$$

$$t_4 = 2.6 \text{ s}$$

The effective torque is obtained as follows, and the rated torque of the motor must be 1305 N•mm or greater.

$$T_{\text{rms}} = \sqrt{\frac{T_k^2 \cdot t_1 + T_i^2 \cdot t_2 + T_g^2 \cdot t_3 + T_s^2 \cdot t_4}{t_1 + t_2 + t_3 + t_4}} = \sqrt{\frac{4730^2 \times 0.15 + 120^2 \times 0.85 + 4490^2 \times 0.15 + 0}{0.15 + 0.85 + 0.15 + 2.6}}$$

$$= 1305 \text{ N} \cdot \text{mm}$$

- **Inertial Moment**

The inertial moment applied to the motor equals to the inertial moment calculated in Section [Studying the Rotational Torque] on **B15-80**.

$$J = 3.39 \times 10^{-3} \text{ kg} \cdot \text{m}^2$$

Normally, the motor needs to have an inertial moment at least one tenth of the inertial moment applied to the motor, although the specific value varies depending on the motor manufacturer.

Therefore, the inertial moment of the AC servomotor must be $3.39 \times 10^{-4} \text{ kg} \cdot \text{m}^2$ or greater.

The selection has been completed.

Vertical Conveyance System

[Selection Conditions]

Table Mass	$m_1 = 40\text{kg}$
Work Mass	$m_2 = 10\text{kg}$
Stroke length	$l_s = 600\text{mm}$
Maximum speed	$V_{\max} = 0.3\text{m/s}$
Acceleration time	$t_1 = 0.2\text{s}$
Deceleration time	$t_3 = 0.2\text{s}$
Number of reciprocations per minute	$n = 5\text{min}^{-1}$
Backlash	0.1mm
Positioning accuracy	$\pm 0.7\text{mm}/600\text{mm}$
Positioning accuracy repeatability	$\pm 0.05\text{mm}$
Minimum feed amount	$s = 0.01\text{mm/pulse}$
Service life time	20000h
Driving motor	AC servo motor Rated rotational speed: $3,000\text{min}^{-1}$
Inertial moment of the motor	$J_m = 5 \times 10^{-6}\text{kg}\cdot\text{m}^2$
Reduction gear	None (direct coupling)
Frictional coefficient of the guide surface	$\mu = 0.003$ (rolling)
Guide surface resistance	$f = 20\text{N}$ (without load)

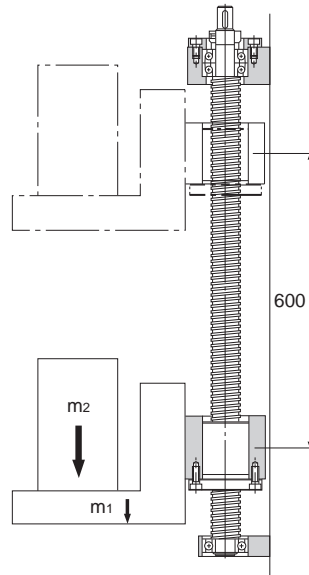

[Selection Items]

Screw shaft diameter
Lead
Nut model No.
Accuracy
Axial clearance
Screw shaft support method
Driving motor

[Selecting Lead Angle Accuracy and Axial Clearance]

● Selecting the Lead Angle Accuracy

To achieve positioning accuracy of $\pm 0.7\text{mm}/600\text{mm}$:

$$\frac{\pm 0.7}{600} = \frac{\pm 0.35}{300}$$

The lead angle accuracy must be $\pm 0.35\text{mm}/300\text{ mm}$ or higher.

Therefore, the accuracy grade of the Ball Screw (see Table1 on [B15-20](#)) needs to be C10 (travel distance error: $\pm 0.21\text{ mm}/300\text{ mm}$).

Accuracy grade C10 is available for low priced, Rolled Ball Screws. Assume that a Rolled Ball Screw is selected.

● Selecting the Axial Clearance

The required backlashes is 0.1 mm or less. However, since an axial load is constantly applied in a single direction with vertical mount, the axial load does not serve as a backlash no matter how large it is.

Therefore, a low price, rolled Ball Screw is selected since there will not be a problem in axial clearance.

[Selecting a Screw Shaft]

● Assuming the Screw Shaft Length

Assume the overall nut length to be 100 mm and the screw shaft end length to be 100 mm.

Therefore, the overall length is determined as follows based on the stroke length of 600mm.

$$600 + 200 = 800\text{ mm}$$

Thus, the screw shaft length is assumed to be 800 mm.

● Selecting the Lead

With the driving motor's rated rotational speed being $3,000\text{ min}^{-1}$ and the maximum speed 0.3 m/s, the Ball Screw lead is obtained as follows:

$$\frac{0.3 \times 60 \times 1000}{3000} = 6\text{ mm}$$

Therefore, it is necessary to select a type with a lead of 6mm or longer.

In addition, the Ball Screw and the motor can be mounted in direct coupling without using a reduction gear. The minimum resolution per revolution of an AC servomotor is obtained based on the resolution of the encoder (1,000 p/rev; 1,500 p/rev) provided as a standard accessory for the AC servomotor, as indicated below.

- 1000 p/rev(without multiplication)
- 1500 p/rev(without multiplication)
- 2000 p/rev(doubled)
- 3000 p/rev(doubled)
- 4000 p/rev(quadrupled)
- 6000 p/rev(quadrupled)

Point of Selection

Examples of Selecting a Ball Screw

To meet the minimum feed amount of 0.010mm/pulse, which is the selection requirement, the following should apply.

Lead	6mm	—	3000 p/rev
	8mm	—	4000 p/rev
	10mm	—	1000 p/rev
	20mm	—	2000 p/rev
	40mm	—	2000 p/rev

However, with the lead being 6 mm or 8 mm, the feed distance is 0.002 mm/pulse, and the starting pulse of the controller that issues commands to the motor driver needs to be at least 150 kpps, and the cost of the controller may be higher.

In addition, if the lead of the Ball Screw is greater, the torque required for the motor is also greater, and thus the cost will be higher.

Therefore, select 10 mm for the Ball Screw lead.

● Selecting the Screw Shaft Diameter

Those Ball Screw models that meet the lead being 10 mm as described in Section [Selecting Lead Angle Accuracy and Axial Clearance] on **B15-84** and Section [Selecting a Screw Shaft] on **B15-84** (see Table20 on **B15-35**) are as follows.

Shaft diameter	Lead
15mm	— 10mm
20mm	— 10mm
25mm	— 10mm

Accordingly, the combination of a screw shaft diameter of 15 mm and a lead 10 mm is selected.

● Selecting the Screw Shaft Support Method

Since the assumed Ball Screw has a stroke length of 600 mm and operates at a maximum speed of 0.3 m/s (Ball Screw rotational speed: 1,800 min⁻¹), select the fixed-supported configuration for the screw shaft support.

● Studying the Permissible Axial Load

■ Calculating the Maximum Axial Load

Guide surface resistance	$f=20$ N (without load)
Table Mass	$m_1 =40$ kg
Work Mass	$m_2 =10$ kg
Maximum speed	$V_{\max}=0.3$ m/s
Acceleration time	$t_1 = 0.2$ s

Accordingly, the required values are obtained as follows.

Acceleration

$$\alpha = \frac{V_{\max}}{t_1} = 1.5 \text{ m/s}^2$$

During upward acceleration:

$$Fa_1 = (m_1 + m_2) \bullet g + f + (m_1 + m_2) \bullet \alpha = 585 \text{ N}$$

During upward uniform motion:

$$Fa_2 = (m_1 + m_2) \bullet g + f = 510 \text{ N}$$

During upward deceleration:

$$Fa_3 = (m_1 + m_2) \bullet g + f - (m_1 + m_2) \bullet \alpha = 435 \text{ N}$$

During downward acceleration:

$$Fa_4 = (m_1 + m_2) \bullet g - f - (m_1 + m_2) \bullet \alpha = 395 \text{ N}$$

During downward uniform motion:

$$Fa_5 = (m_1 + m_2) \bullet g - f = 470 \text{ N}$$

During downward deceleration:

$$Fa_6 = (m_1 + m_2) \bullet g - f + (m_1 + m_2) \bullet \alpha = 545 \text{ N}$$

Thus, the maximum axial load applied on the Ball Screw is as follows:

$$Fa_{\max} = Fa_1 = 585 \text{ N}$$

■ Buckling Load of the Screw Shaft

Factor according to the mounting method

$\eta_2=20$ (see [B 15-38](#))

Since the mounting method for the section between the nut and the bearing, where buckling is to be considered, is "fixed-fixed: "

Distance between two mounting surfaces

$\ell_a=700$ mm (estimate)

Screw-shaft thread minor diameter

$d_1=12.5$ mm

$$P_1 = \eta_2 \cdot \frac{d_1^4}{\ell_a^2} \times 10^4 = 20 \times \frac{12.5^4}{700^2} \times 10^4 = 9960 \text{ N}$$

■ Permissible Compressive and Tensile Load of the Screw Shaft

$$P_2 = 116d_1^2 = 116 \times 12.5^2 = 18100 \text{ N}$$

Thus, the buckling load and the permissible compressive and tensile load of the screw shaft are at least equal to the maximum axial load. Therefore, a Ball Screw that meets these requirements can be used without a problem.

- Studying the Permissible Rotational Speed

- Maximum Rotational Speed

- Screw shaft diameter: 15mm; lead: 10mm

Maximum speed

$$V_{\max}=0.3 \text{ m/s}$$

Lead

$$Ph=10 \text{ mm}$$

$$N_{\max} = \frac{V_{\max} \times 60 \times 10^3}{Ph} = 1800 \text{ min}^{-1}$$

- Permissible Rotational Speed Determined by the Dangerous Speed of the Screw Shaft

Factor according to the mounting method

$$\lambda_{z2}=15.1 \text{ (see B15-40)}$$

Since the mounting method for the section between the nut and the bearing, where dangerous speed is to be considered, is "fixed-supported: "

Distance between two mounting surfaces

$$\ell_b=700 \text{ mm (estimate)}$$

- Screw shaft diameter: 15mm; lead: 10mm

Screw-shaft thread minor diameter

$$d_1=12.5 \text{ mm}$$

$$N_1 = \lambda_{z2} \times \frac{d_1}{\ell_b^2} \times 10^7 = 15.1 \times \frac{12.5}{700^2} \times 10^7 = 3852 \text{ min}^{-1}$$

- Permissible Rotational Speed Determined by the DN Value

- Screw shaft diameter: 15mm; lead: 10mm (large lead Ball Screw)

Ball center-to-center diameter

$$D=15.75 \text{ mm}$$

$$N_2 = \frac{70000}{D} = \frac{70000}{15.75} = 4444 \text{ min}^{-1}$$

Thus, the dangerous speed and the DN value of the screw shaft are met.

[Selecting a Nut]

● Selecting a Nut Model Number

The Rolled Ball Screw with a screw shaft diameter of 15 mm and a lead of 10 mm is the following large-lead Rolled Ball Screw model.

BLK1510-5.6

($C_a=9.8$ kN, $C_{0a}=25.2$ kN)

● Studying the Permissible Axial Load

Assuming that an impact load is applied during an acceleration and a deceleration, set the static safety factor (f_s) at 2 (see Table 1 on **B15-47**).

$$F_{a_{\max}} = \frac{C_{0a}}{f_s} = \frac{25.2}{2} = 12.6 \text{ kN} = 12600 \text{ N}$$

The obtained permissible axial load is greater than the maximum axial load of 585 N, and therefore, there will be no problem with this model.

● Studying the Service Life

■ Calculating the Travel Distance

Maximum speed $V_{\max}=0.3$ m/s

Acceleration time $t_1 = 0.2$ s

Deceleration time $t_3 = 0.2$ s

- Travel distance during acceleration

$$\ell_{1,4} = \frac{V_{\max} \cdot t_1}{2} \times 10^3 = \frac{0.3 \times 0.2}{2} \times 10^3 = 30 \text{ mm}$$

- Travel distance during uniform motion

$$\ell_{2,5} = \ell_s - \frac{V_{\max} \cdot t_1 + V_{\max} \cdot t_3}{2} \times 10^3 = 600 - \frac{0.3 \times 0.2 + 0.3 \times 0.2}{2} \times 10^3 = 540 \text{ mm}$$

- Travel distance during deceleration

$$\ell_{3,6} = \frac{V_{\max} \cdot t_3}{2} \times 10^3 = \frac{0.3 \times 0.2}{2} \times 10^3 = 30 \text{ mm}$$

Based on the conditions above, the relationship between the applied axial load and the travel distance is shown in the table below.

Motion	Applied axial load $F_{a(N)}$	Travel distance $\ell_N(\text{mm})$
No1: During upward acceleration	585	30
No2: During upward uniform motion	510	540
No3: During upward deceleration	435	30
No4: During downward acceleration	395	30
No5: During downward uniform motion	470	540
No6: During downward deceleration	545	30

* The subscript (N) indicates a motion number.

■Average Axial Load

$$F_m = \sqrt[3]{\frac{1}{2 \times l_s} (F_{a1}^3 \cdot l_1 + F_{a2}^3 \cdot l_2 + F_{a3}^3 \cdot l_3 + F_{a4}^3 \cdot l_4 + F_{a5}^3 \cdot l_5 + F_{a6}^3 \cdot l_6)} = 492 \text{ N}$$

■Nominal Life

Dynamic load rating	Ca= 9800 N
Load factor	f _w = 1.5 (see Table2 on B15-48)
Average load	F _m = 492 N
Nominal life	L (rev)

$$L = \left(\frac{C_a}{f_w \cdot F_m} \right)^3 \times 10^6 = \left(\frac{9800}{1.5 \times 492} \right)^3 \times 10^6 = 2.34 \times 10^9 \text{ rev}$$

■Average Revolutions per Minute

Number of reciprocations per minute	n = 5 min ⁻¹
Stroke	l _s =600 mm
Lead	Ph= 10 mm

$$N_m = \frac{2 \times n \times l_s}{Ph} = \frac{2 \times 5 \times 600}{10} = 600 \text{ min}^{-1}$$

■Calculating the Service Life Time on the Basis of the Nominal Life

Nominal life	L=2.34 × 10 ⁹ rev
Average revolutions per minute	N _m = 600 min ⁻¹

$$L_h = \frac{L}{60 \cdot N_m} = \frac{2.34 \times 10^9}{60 \times 600} = 65000 \text{ h}$$

■Calculating the Service Life in Travel Distance on the Basis of the Nominal Life

Nominal life	L=2.34 × 10 ⁹ rev
Lead	Ph= 10 mm
L _s = L × Ph × 10 ⁻⁶	= 23400 km

With all the conditions stated above, model BLK1510-5.6 satisfies the desired service life time of 20,000 hours.

[Studying the Rigidity]

Since the conditions for selection do not include rigidity and this element is not particularly necessary, it is not described here.

[Studying the Positioning Accuracy]

● Studying the Lead Angle Accuracy

Accuracy grade C10 was selected in Section [Selecting Lead Angle Accuracy and Axial Clearance] on **B15-84**.

C10 (travel distance error: $\pm 0.21\text{mm}/300\text{mm}$)

● Studying the Axial Clearance

Since the axial load is constantly present in a given direction only because of vertical mount, there is no need to study the axial clearance.

● Studying the Axial Rigidity

Since the lead angle accuracy is achieved beyond the required positioning accuracy, there is no need to study the positioning accuracy determined by axial rigidity.

● Studying the Thermal Displacement through Heat Generation

Since the lead angle accuracy is achieved beyond the required positioning accuracy, there is no need to study the positioning accuracy determined by the heat generation.

● Studying the Orientation Change during Traveling

Since the lead angle accuracy is achieved at a much higher degree than the required positioning accuracy, there is no need to study the positioning accuracy.

[Studying the Rotational Torque]

● Frictional Torque Due to an External Load

During upward uniform motion:

$$T_1 = \frac{F_{a2} \cdot Ph}{2 \times \pi \times \eta} = \frac{510 \times 10}{2 \times \pi \times 0.9} = 900 \text{ N} \cdot \text{mm}$$

During downward uniform motion:

$$T_2 = \frac{F_{a5} \cdot Ph}{2 \times \pi \times \eta} = \frac{470 \times 10}{2 \times \pi \times 0.9} = 830 \text{ N} \cdot \text{mm}$$

● Torque Due to a Preload on the Ball Screw

The Ball Screw is not provided with a preload.

● Torque Required for Acceleration

Inertial Moment:

Since the inertial moment per unit length of the screw shaft is $3.9 \times 10^{-4} \text{ kg} \cdot \text{cm}^2/\text{mm}$ (see the specification table), the inertial moment of the screw shaft with an overall length of 800mm is obtained as follows.

$$J_s = 3.9 \times 10^{-4} \times 800 = 0.31 \text{ kg} \cdot \text{cm}^2 \\ = 0.31 \times 10^{-4} \text{ kg} \cdot \text{m}^2$$

$$J = (m_1 + m_2) \left(\frac{Ph}{2 \times \pi} \right)^2 \cdot A^2 \times 10^{-6} + J_s \cdot A^2 = (40 + 10) \left(\frac{10}{2 \times \pi} \right)^2 \times 1^2 \times 10^{-6} + 0.31 \times 10^{-4} \times 1^2 \\ = 1.58 \times 10^{-4} \text{ kg} \cdot \text{m}^2$$

Angular acceleration:

$$\omega' = \frac{2\pi \cdot N_{\text{max}}}{60 \cdot t} = \frac{2\pi \times 1800}{60 \times 0.2} = 942 \text{ rad/s}^2$$

Based on the above, the torque required for acceleration is obtained as follows.

$$T_3 = (J + J_m) \cdot \omega' = (1.58 \times 10^{-4} + 5 \times 10^{-5}) \times 942 = 0.2 \text{ N} \cdot \text{m} = 200 \text{ N} \cdot \text{mm}$$

Therefore, the required torque is specified as follows.

During upward acceleration:

$$T_{k1} = T_1 + T_3 = 900 + 200 = 1100 \text{ N} \cdot \text{mm}$$

During upward uniform motion:

$$T_{t1} = T_1 = 900 \text{ N} \cdot \text{mm}$$

During upward deceleration:

$$T_{g1} = T_1 - T_3 = 900 - 200 = 700 \text{ N} \cdot \text{mm}$$

During downward acceleration:

$$T_{k2} = 630 \text{ N} \cdot \text{mm}$$

During downward uniform motion:

$$T_{t2} = 830 \text{ N} \cdot \text{mm}$$

During downward deceleration:

$$T_{g2} = 1030 \text{ N} \cdot \text{mm}$$

[Studying the Driving Motor]

● Rotational Speed

Since the Ball Screw lead is selected based on the rated rotational speed of the motor, it is unnecessary to study the rotational speed of the motor.

Maximum working rotational speed : 1800 min^{-1}

Rated rotational speed of the motor: 3000 min^{-1}

● Minimum Feed Amount

As with the rotational speed, the Ball Screw lead is selected based on the encoder normally used for an AC servomotor. Therefore, it is unnecessary to study this factor.

Encoder resolution: 1000 p/rev .

● Motor Torque

The torque during acceleration calculated in Section [Studying the Rotational Torque] on **B15-90** is the required maximum torque.

$$T_{\max} = T_{k1} = 1100 \text{ N}\cdot\text{mm}$$

Therefore, the maximum peak torque of the AC servomotor needs to be at least $1100 \text{ N}\cdot\text{mm}$.

● Effective Torque Value

The selection requirements and the torque calculated in Section [Studying the Rotational Torque] on **B15-90** can be expressed as follows.

During upward acceleration:

$$T_{k1} = 1100 \text{ N}\cdot\text{mm}$$

$$t_1 = 0.2 \text{ s}$$

During upward uniform motion:

$$T_{t1} = 900 \text{ N}\cdot\text{mm}$$

$$t_2 = 1.8 \text{ s}$$

During upward deceleration:

$$T_{g1} = 700 \text{ N}\cdot\text{mm}$$

$$t_3 = 0.2 \text{ s}$$

During downward acceleration:

$$T_{k2} = 630 \text{ N}\cdot\text{mm}$$

$$t_1 = 0.2 \text{ s}$$

During downward uniform motion:

$$T_{t2} = 830 \text{ N}\cdot\text{mm}$$

$$t_2 = 1.8 \text{ s}$$

During downward deceleration:

$$T_{g2} = 1030 \text{ N}\cdot\text{mm}$$

$$t_3 = 0.2 \text{ s}$$

When stationary($m_2=0$):

$$T_s = 658 \text{ N}\cdot\text{mm}$$

$$t_4 = 7.6 \text{ s}$$

The effective torque is obtained as follows, and the rated torque of the motor must be 743 N•mm or greater.

$$T_{rms} = \sqrt{\frac{T_{k1}^2 \cdot t_1 + T_{t1}^2 \cdot t_2 + T_{g1}^2 \cdot t_3 + T_{k2}^2 \cdot t_1 + T_{t2}^2 \cdot t_2 + T_{g2}^2 \cdot t_3 + T_s^2 \cdot t_4}{t_1 + t_2 + t_3 + t_1 + t_2 + t_3 + t_4}}$$

$$= \sqrt{\frac{1100^2 \times 0.2 + 900^2 \times 1.8 + 700^2 \times 0.2 + 630^2 \times 0.2 + 830^2 \times 1.8 + 1030^2 \times 0.2 + 658^2 \times 7.6}{0.2 + 1.8 + 0.2 + 0.2 + 1.8 + 0.2 + 7.6}}$$

$$= 743 \text{ N} \cdot \text{mm}$$

● Inertial Moment

The inertial moment applied to the motor equals to the inertial moment calculated in Section [Studying the Rotational Torque] on **B15-90**.

$$J = 1.58 \times 10^{-4} \text{ kg} \cdot \text{m}^2$$

Normally, the motor needs to have an inertial moment at least one tenth of the inertial moment applied to the motor, although the specific value varies depending on the motor manufacturer.

Therefore, the inertial moment of the AC servomotor must be $1.58 \times 10^{-5} \text{ kg} \cdot \text{m}^2$ or greater.

The selection has been completed.

Ball Screw Options

Contaminaton Protection

If foreign material enters the interior of the ball screw, abnormal levels of abrasion and ball clogging are more likely to occur. This can also shorten the overall lifespan of the product.

As such, foreign material needs to be prevented from entering. If there is a chance that foreign material may get in, it is important to choose an effective contamination protection product that suits the usage conditions.

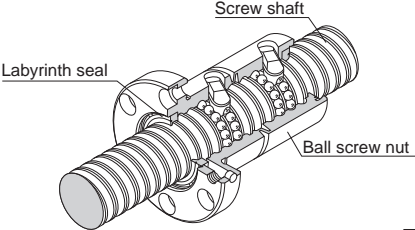
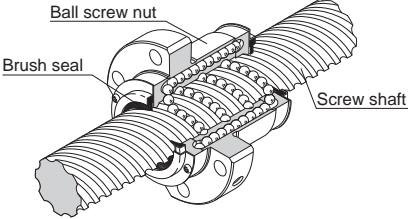
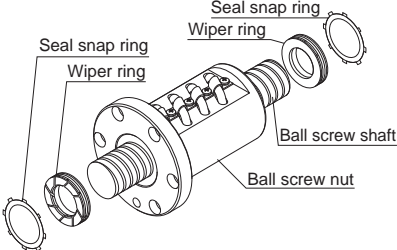
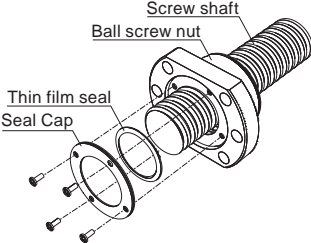
<p>Labyrinth seal (Precision Ball Screw) (Rolled Ball Screw Model JPF) Symbol: RR</p>	 <p style="text-align: right;">▲15-338</p>
<p>Brush seal (Rolled Ball Screw) Symbol: ZZ</p>	 <p style="text-align: right;">▲15-338</p>
<p>Wiper ring Symbol: WW</p>	 <p style="text-align: right;">▲15-339~</p>
<p>Thin film seal (SDA-V only) Symbol: TT</p>	

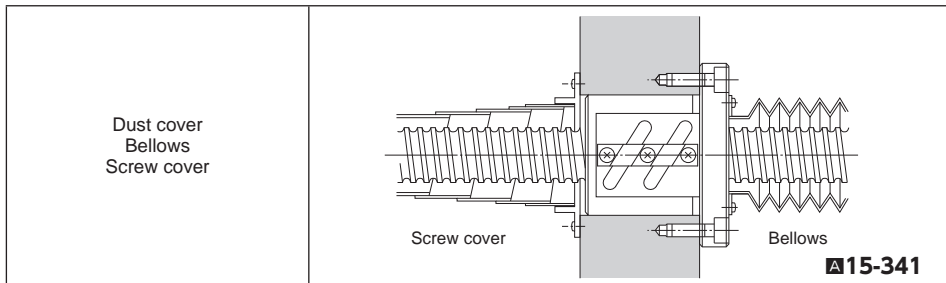

Lubrication

To maximize the performance of the Ball Screw, it is necessary to select a lubricant and a lubrication method according to the conditions.

For types of lubricants, characteristics of lubricants and lubrication methods, see the section on “Accessories for Lubrication” on **A24-2**.

Also, QZ Lubricator is available as an optional accessory that significantly increases the maintenance interval.

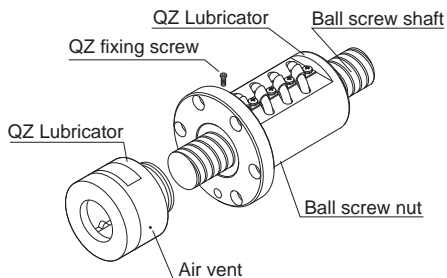

QZ Lubricator

A15-342~

Corrosion Resistance (Surface Treatment, etc.)

Depending on the service environment, the Ball Screw requires corrosion resistance treatment or a different material. For details of corrosion resistance treatment and material change, contact THK. (see **B0-18**)

Contamination Protection Seal for Ball Screws

If the Ball Screw is used in an atmosphere free from foreign material but with suspended dust, a labyrinth seal (with symbol RR) and a brush seal (with symbol ZZ) can be used as contamination protection accessories.

The labyrinth seal is designed to maintain a slight clearance between the seal and the screw shaft raceway so that torque does not develop and no heat is generated, though its effect in contamination protection is limited.

With Ball Screws except the large lead and super lead types, there is no difference in nut dimensions between those with and without a seal.

Labyrinth seal

Symbol: RR (Precision Ball Screw)
(Rolled Ball Screw Model JPF)

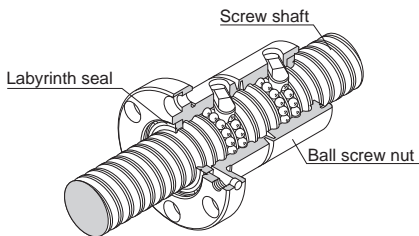

Labyrinth seal

Brush seal

Symbol: ZZ (Rolled Ball Screw)

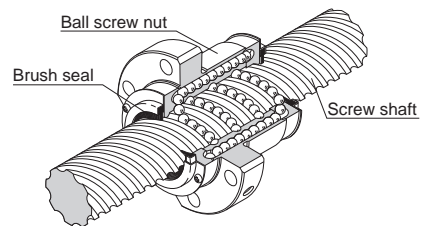

Brush seal

Wiper Ring W

● For the supported models and the ball screw nut dimension with Wiper ring W attached, see [A15-344](#) to [A15-351](#).

With the wiper ring W, special resin with high wear resistance and low dust generation removes foreign material and prevents foreign material from entering the ball screw nut while elastically contacting the circumference of the ball screw shaft and the screw thread.

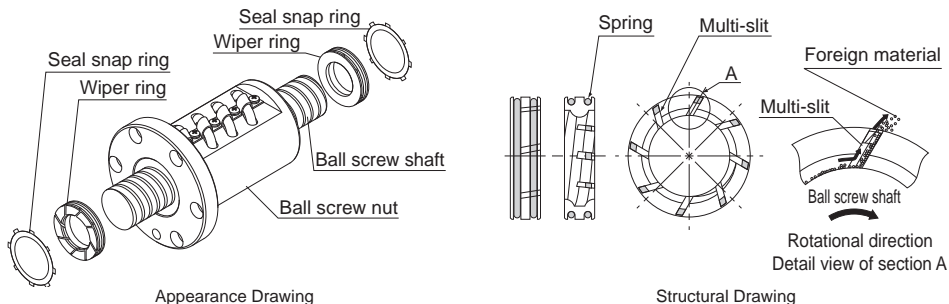

[Features]

- A total of eight slits on the circumference remove foreign materials in succession, and prevent entrance of foreign material.
- Contacts the ball screw shaft to reduce the flowing out of grease.
- Contacts the ball screw shaft at a constant pressure level using a spring, thus to minimize the heat generation.
- Since the material is highly resistant to the wear and the chemicals, its performance will not easily be deteriorated even if it is used over a long period.

Can be attached together with QZ Lubricator.

For the applicable models and the ball screw nut dimensions after wiper ring W is attached, see [A15-344](#).

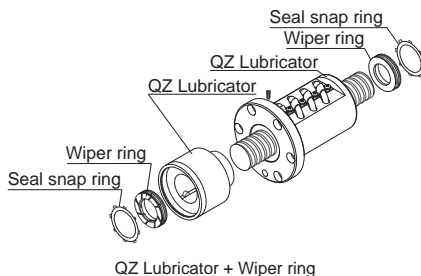

Model number coding

BIF2505V-5 QZ WW G0 +1000L C5

With QZ
Lubricator

With wiper ring W

(*) See [A15-344](#).

● Test in an environment exposed to contaminated environment

[Test conditions]

Item	Description
Model No.	BIF3210V-5G0+1500LC5
Maximum rotational speed	1000min ⁻¹
Maximum speed	10m/min
Maximum circumferential speed	1.8m/s
Time constant	60ms
Dowel	1s
Stroke	900mm
Load (through internal load)	1.31kN
Grease	THK AFG Grease 8cm ³ (Initial lubrication to the ball screw nut only.)
Foundry dust	FCD400 average particle diameter: 250μm
Volume of foreign material per shaft	5g/h

[Test result]

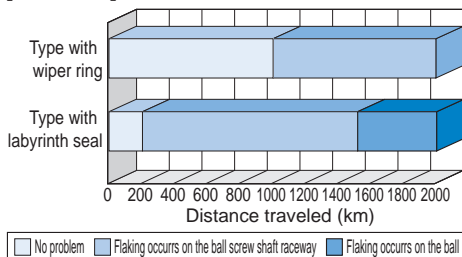

- Type with wiper ring
Slight flaking occurred in the ball screw shaft at travel distant of 1,000 km.
- Type with labyrinth seal
Flaking occurred throughout the circumference of the screw shaft raceway at travel distance of 200 km.
Flaking occurred on the balls after traveling 1,500 km.

Change in the ball after traveling 2000 km

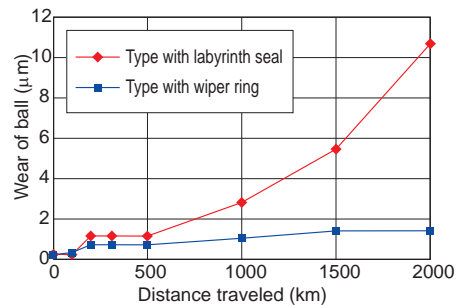
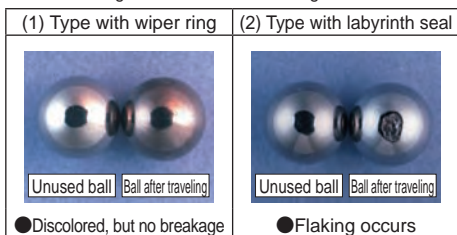

- Type with wiper ring
Wear of balls at a travel distance of 2,000 km: 1.4 μm.
- Type with labyrinth seal
Starts to be worn rapidly after 500 km, and the ball wear amount at the travel distance of 2,000 km: 11 μm.

● Heat Generation Test

[Test conditions]

Item	Description
Model No.	BLK3232-3.6G0+1426LC5
Maximum rotational speed	1000min ⁻¹
Maximum speed	32m/min
Maximum circumferential speed	1.7m/s
Time constant	100ms
Stroke	1000mm
Load (through internal load)	0.98kN
Grease	THK AFG Grease 5cm ³ (contained in the ball screw nut)

[Test result]

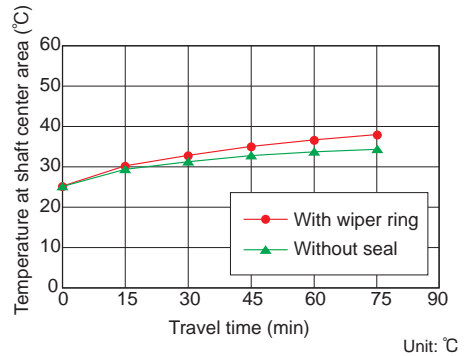

Item	With wiper ring	Without seal
Heat generation temperature	37.1	34.5
Temperature rise	12.2	8.9

Dust Cover for Ball Screws

Bellows/Screw cover

In the case of an environment with much dust and foreign material, be sure to prevent intrusion of foreign material by using bellows, a screw cover or the like. The contamination protection can be increased by also using a contamination protection seal. For details, contact THK. When conferring with us, please use the bellows specifications (A15-352).

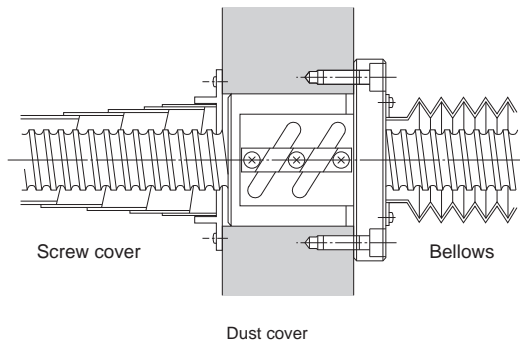

QZ Lubricator

● For the supported models and the ball screw nut dimension with QZ attached, see [A15-344](#) to [A15-351](#).

QZ Lubricator feeds a right amount of lubricant to the raceway of the ball screw shaft. This allows an oil film to be constantly formed between the balls and the raceway, improves lubricity and significantly extends the lubrication maintenance interval.

The structure of QZ Lubricator consists of three major components: (1) a heavily oil-impregnated fiber net (stores the lubricant), (2) a high-density fiber net (applies the lubricant to the raceway) and (3) an oil-control plate (adjusts the oil flow). The lubricant contained in the QZ Lubricator is fed by the capillary phenomenon, which is used also in felt pens and many other products.

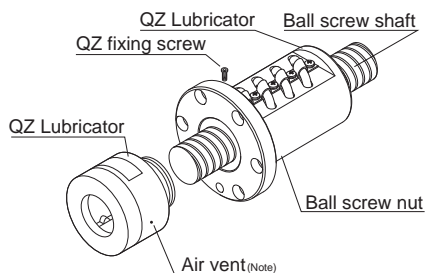

Appearance Drawing

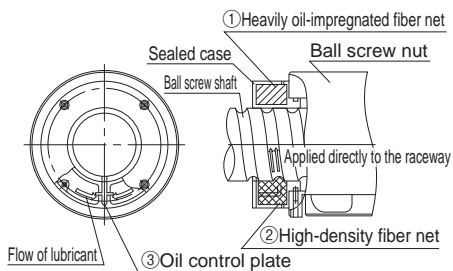

Structural Drawing

[Features]

- Since it supplements an oil loss, the lubrication maintenance interval can be significantly extended.
- Since the right amount of lubricant is applied to the ball raceway, an environmentally friendly lubrication system that does not contaminate the surroundings is achieved.

Note) Some types of QZ have a vent hole. Be careful not to block the hole with grease or other obstructions.

Model number coding

BIF2505V-5 QZ WW G0 +1000L C5

With QZ
Lubricator

With wiper ring W

(* See [A15-344](#).)

● Significantly extended maintenance interval

Since QZ Lubricator continuously feeds a lubricant over a long period, the maintenance interval can be significantly extended.

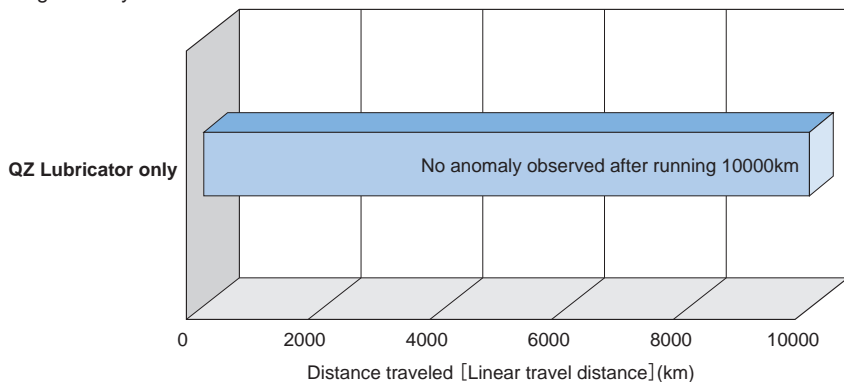

[Test conditions]

Item	Description
Ball Screw	BIF2510V
Maximum rotational speed	2500min ⁻¹
Maximum speed	25m/min
Stroke	500mm
Load	Internal preload only

● Environmentally friendly lubrication system

Since QZ Lubricator feeds the right amount of lubricant directly to the raceway, the lubricant can effectively be used without waste.

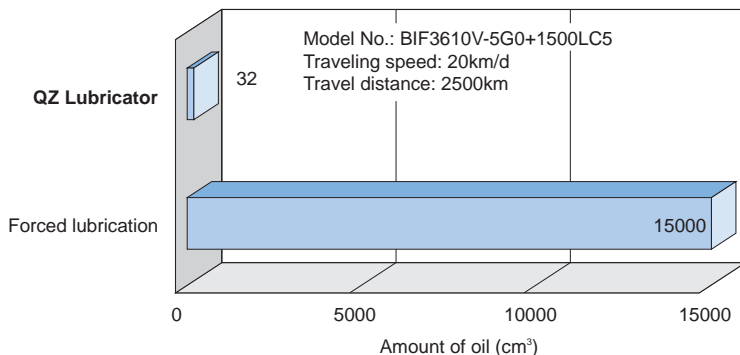

QZ Lubricator + THK AFA Grease

32cm³

(QZ Lubricator attached to both ends of the ball screw nut)



Forced lubrication

**0.25cm³/3min×24h×125d
=15000cm³**

Reduced to approx. $\frac{1}{470}$

Mounting Procedure

Installing the Support Unit

- (1) Install the fixed side Support Unit with the screw shaft.
- (2) After inserting the fixed side Support Unit, secure the lock nut using the fastening set piece and the hexagonal socket-head setscrews.
- (3) Attach the supported side bearing to the screw shaft and secure the bearing using the snap ring, and then install the assembly to the housing on the supported side.

Note1) Do not disassemble the Support Unit.

Note2) When inserting the screw shaft to the Support Unit, take care not to let the oil seal lip turn outward.

Note3) When securing the set piece with a hexagonal socket-head setscrew, apply an adhesive to the hexagonal socket-head setscrew before tightening it in order to prevent the screw from loosening. If planning to use the product in a harsh environment, it is also necessary to take a measure to prevent other components/parts from loosening. Contact THK for details.

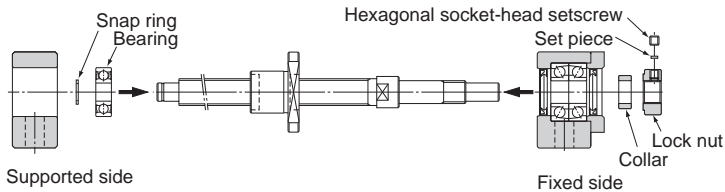

Installation onto the Table and the Base

- (1) If using a bracket when mounting the ball screw nut to the table, insert the nut into the bracket and temporarily fasten it.
- (2) Temporarily fasten the fixed side Support Unit to the base. In doing so, press the table toward the fixed side Support Unit to align the axial center, and adjust the table so that it can travel freely.
 - If using the fixed side Support Unit as the reference point, secure a clearance between the ball screw nut and the table or inside the bracket when making adjustment.
 - If using the table as the reference point, make the adjustment either by using the shim (for a square type Support Unit), or securing the clearance between the outer surface of the nut and the inner surface of the mounting section (for a round type Support Unit).
- (3) Press the table toward the fixed-side Support Unit to align the axial center. Make the adjustment by reciprocating the table several times so that the nut travels smoothly throughout the whole stroke, and temporarily secure the Support Unit to the base.

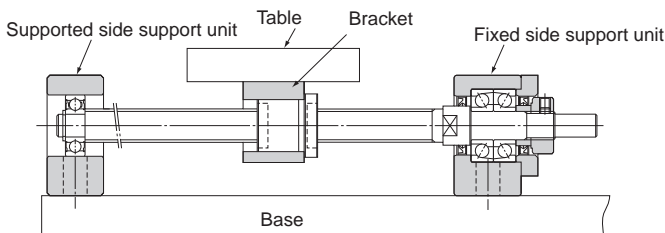

Checking the Accuracy and Fully Fastening the Support Unit

While checking the runout of the ball screw shaft end and the axial clearance using a dial gauge, fully fasten the ball screw nut, the nut bracket, the fixed side Support Unit and the supported-side Support Unit, in this order.

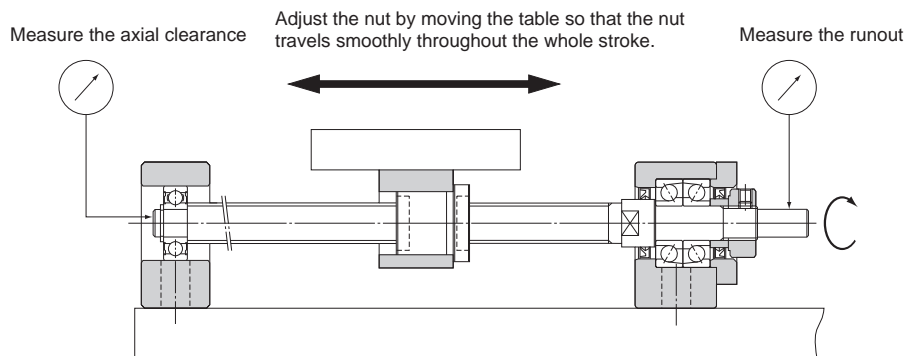

Connection with the Motor

- (1) Mount the motor bracket to the base.
- (2) Connect the motor and the ball screw using a coupling.
Note) Make sure the mounting accuracy is maintained.
- (3) Thoroughly perform the break-in for the system.

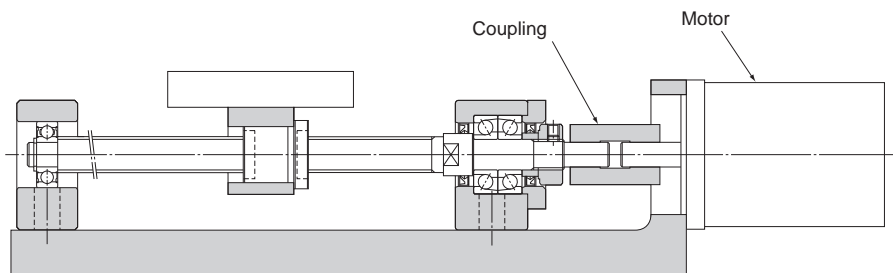

Maintenance Method

Amount of Lubricant

If the amount of the lubricant to the Ball Screw is insufficient, it may cause a lubrication breakdown, and if it is excessive, it may generate heat and increase resistance. It is necessary to select an amount that meets the conditions.

[Grease]

The feed amount of grease is generally approximately one third of the spatial volume inside the nut. For details on feed amount of grease, contact THK.

[Oil]

Table 1 shows a guideline for the feed amount of oil.

Note, that the amount varies according to the stroke, the oil type and the conditions (e.g., suppressed heat generation).

Table1 Guideline for the Feed Amount of Oil
(Interval: 3 minutes)

Shaft diameter (mm)	Amount of lubricant (cc)
4 to 8	0.03
10 to 14	0.05
15 to 18	0.07
20 to 25	0.1
28 to 32	0.15
36 to 40	0.25
45 to 50	0.3
55 to 63	0.4
70 to 100	0.5

Model Number Coding

The model number configuration for ball screws differs depending on the type. Table 2 Refer to the corresponding configuration example shown in Table 4.

THK can also provide shaft end shapes matched to support units. These can also be denoted in the symbols, which should be used for this purpose.

[Precision ball screw types and sample model number configurations]

Table 2

	Model No.		Shaft end shape	Model number coding
Precision	SBN-V, SBK, SDA-V, HBN, SBKH, BIF-V, BNFN-V/BNFN, MDK, MBF, BNF-V/BNF, DIK, DKN, BLW, DK, MDK, WHF, BLK, WGF, BNT		Fixed Side : H, J Supported Side : K	[1]
	Unfinished Shaft Ends A	MBF, MDK, BNF, BIF		[2]
	Unfinished Shaft Ends B	BNF, BIF	Y	[3]
	Finished Shaft Ends	BNK		[4]
	Rotary Ball Screw	BLR, DIR	Fixed Side : H, J Supported Side : K	[5]
	Ball Screw/Spline	BNS-A, BNS, NS-A, NS	—	[6]

[Rolled ball screw types and sample model number configurations]

Table 3

	Model No.		Shaft end shape	Model number coding
Rolled	Unfinished Shaft Ends	MTF	Fixed Side : H, J Supported Side : K	[6]
	Ball screw nut and screw shaft combination products	JPF, BTK-V, MTF, WHF, BLK, WTF, CNF, BNT		[7]
	Rotary Ball Screw	BLR		[8]
	Standalone screw shafts	TS		[9]
	Standalone ball screw nuts	BTK-V, BLK, WTF, CNF, BNT, BLR	—	[10]

[Support unit, nut bracket and lock nut types and sample model number configurations]

Table 4

Model No.		Shaft end shape	Model number coding
Support Unit	EK, BK, FK, EF, BF, FF	—	[10]
Nut brackets for BNK	MC	—	
Lock Nut	RN	—	

[1 Precision Ball Screw]

- Models SBN-V, SBK, SDA-V, HBN, SBKH, BIF-V, BNFN-V/BNFN, MDK, MBF, BNF-V/BNF, DIK, DKN, BLW, DK, MDK, WHF, BLK, WGF and BNT

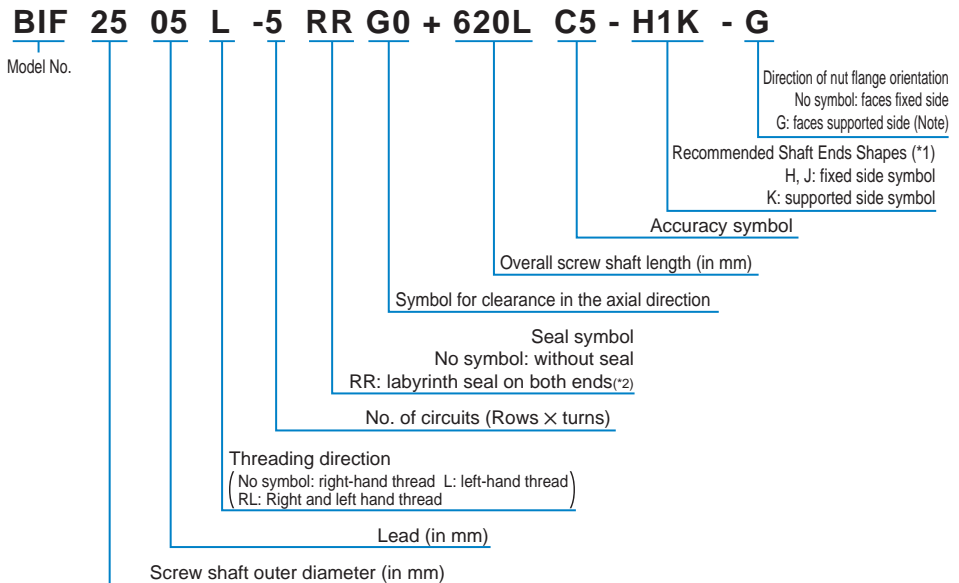

(*1) See **A15-324** to **A15-329**.

(*2) See **B15-96**.

Note) The ball nut flange faces the fixed side unless otherwise specified.

If desiring the flange to face the supported side, add symbol G in the end of the Ball Screw model number when placing an order.

[2 Precision Ball Screw Unfinished Shaft Ends]

- Models BIF, MDK, MBF and BNF

BIF2505-5RRG0+720LC5A

Unfinished shaft ends code (A or B)

Refer to **A15-110** for the corresponding model number.

[3 Precision Ball Screw Finished Shaft Ends]

- Model BNK

BNK2020-5+620LC5Y

Finished shaft ends code

Refer to **■15-136** for the corresponding model number.

[4 Rotary Ball Screw]

- Models BLR and DIR

BLR2020-3.6 K UU G1 +1000L C5

Model No. Flange orientation symbol Symbol for clearance in the axial direction Symbol for support bearing seal Overall screw shaft length (in mm) Accuracy symbol

[5 Ball Screw/Spline]

- Models BNS-A, BNS, NS-A and NS

BNS2525 +600L

Model No. Overall shaft length (in mm)

[6 Rolled Ball Screw Unfinished Shaft Ends]

- Model MTF

MTF 08 02 +250L C7 T - H1

Model No. Overall shaft length (in mm) Recommended Shaft Ends Shapes (See **■15-324**~ onward) Symbol for ball screw shaft Accuracy symbol (No symbol for Normal Grade)

Screw shaft outer diameter (in mm) Lead (in mm)

[7 Rolled Ball Screw]

● Models BTK-V, MTF, WHF, BLK, WTF, CNF and BNT(Rolled)

- Combination of the Ball Screw Nut and the Screw Shaft

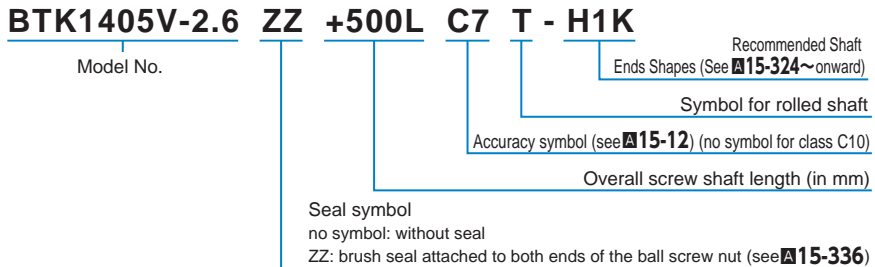

[8 Rolled Ball Screw]

● Model JPF

- Rolled Ball Screw model JPF

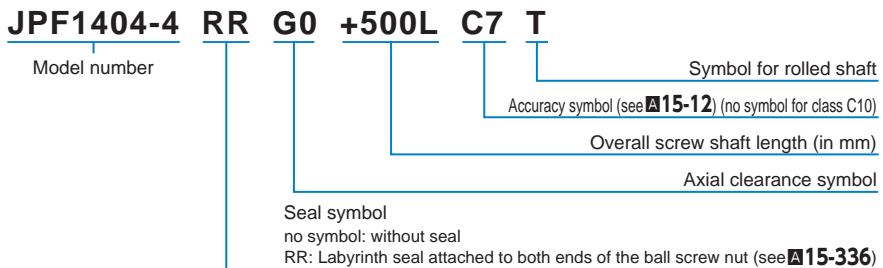

[9 Rolled Rotary Ball Screw]

● Model BLR (Rolled)

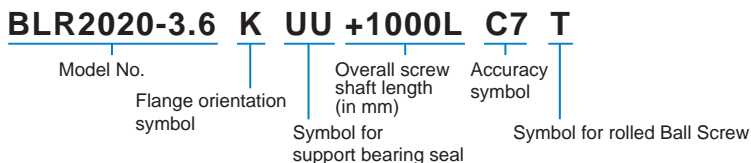

Note) For clearance in the axial direction, see [B15-27](#).

[10 Standalone rolled shafts/nuts]

- Models BTK-V, BLK/WTF, CNF, BNT(Rolled), BLR(Rolled) and TS

Rolled shaft only

Nut only

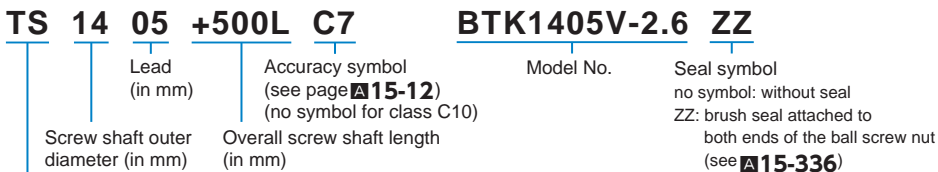

Symbol for rolled ball screw shaft

[11 Support units, nut brackets and lock nuts]

- Models EK, BK, FK, EF, BF, FF, MC and RN

EK12

|
Model No.

[12 Ball screw options, W wiper rings and QZ lubricators]

BIF2505V-5 QZ WW G0 +1000L C5

|
With QZ
Lubricator

|
With wiper ring W

(*) See [15-344](#).

Notes on Ordering

[Options]

The details of the product options differ according to the model number. Check before ordering. See [15-95](#).

[Other notes on specifications]

Contact THK separately for information on the specifications below.

- Shaft end shape (for recommended shaft end shapes, indicate the symbol).
- Surface Treatment (see [10-20](#))
- Grease used
- Nipple mounting

[Handling]

- (1) Please use at least two people to move any product weighing 20 kg or more, or use a dolly or another conveyance. Doing so may cause injury or damage.
- (2) Do not disassemble the parts. This will result in loss of functionality.
- (3) Tilting the Ball Screw shaft and the Ball Screw nut may cause them to fall by their own weight.
- (4) Take care not to drop or strike the Ball Screw. Failure to do so could cause injury or product damage. Giving an impact to it could also cause damage to its function even if the product looks intact.
- (5) When assembling, do not remove the Ball Screw nut from the Ball Screw shaft.
- (6) When handling the product, wear protective gloves, safety shoes, etc., as necessary to ensure safety.

[Precautions on Use]

- (1) Prevent foreign material, such as cutting chips or coolant, from entering the product. Failure to do so may cause damage.
- (2) If the product is used in an environment where cutting chips, coolant, corrosive solvents, water, etc., may enter the product, use bellows, covers, etc., to prevent them from entering the product.
- (3) Do not use the product at temperature of 80°C or higher. Except for the heat-resistant models, exposure to higher temperatures may cause the resin/rubber parts to deform/be damaged.
- (4) If foreign material such as cutting chips adheres to the product, replenish the lubricant after cleaning the product.
- (5) Micro-oscillation makes it difficult for oil film to form on the raceway in contact with the rolling element, and may lead to fretting. Accordingly, use grease offering excellent fretting toughness. It is also recommended that the Ball Screw nut be turned once or so on a regular basis to make sure oil film is formed between the raceway and rolling element.
- (6) Do not use undue force when fitting parts (pin, key, etc.) to the product. This may generate pressure marks on the raceway, leading to loss of functionality.
- (7) If an offset or skewing occurs with the Ball Screw shaft support and the Ball Screw nut, it may substantially shorten the service life. Pay much attention to components to be mounted and to the mounting accuracy.
- (8) If any of the rolling elements falls from the Ball Screw nut, contact THK instead of using the product.
- (9) When using this product with a vertical orientation, take preventive measures such as adding a safety mechanism to prevent falls. The own weight of the Ball Screw nut may cause it to fall.
- (10) Do not use this product beyond its permissible rotational speed. Doing so may cause accidents or component damage. Be sure to use the product within the specification range designated by THK.
- (11) Do not cause the Ball Screw nut to overshoot. The ball may drop, circulating parts may be damaged, raceway in contact with the ball may develop pressure marks, etc., resulting in malfunction. Continuing to use the product in this condition may lead to premature wear or damage to circulating parts.
- (12) Use the Ball Screw by providing a LM Guide, Ball Spline or other guide element. Otherwise, the Ball Screw may be damaged.
- (13) Insufficient rigidity or accuracy of mounting members causes the bearing load to concentrate on one point and the bearing performance will drop significantly. Accordingly, give sufficient consideration to the rigidity/accuracy of the housing and base and strength of the fixing bolts.

[Lubrication]

- (1) Thoroughly wipe off anti-rust oil and feed lubricant before using the product.
- (2) Do not mix different lubricants. Mixing greases using the same type of thickening agent may still cause adverse interaction between the two greases if they use different additives, etc.
- (3) When using the product in locations exposed to constant vibrations or in special environments such as clean rooms, vacuum and low/high temperature, use the grease appropriate for the specification/environment.
- (4) When lubricating the product having no grease nipple or oil hole, apply grease directly on the raceway and stroke the product several times to let the grease spread inside.
- (5) The consistency of grease changes according to the temperature. Take note that the torque of the Ball Screw also changes as the consistency of grease changes.
- (6) After lubrication, the rotational torque of the Ball Screw may increase due to the agitation resistance of grease. Be sure to perform a break-in to let the grease spread fully, before operating the machine.
- (7) Excess grease may scatter immediately after lubrication, so wipe off scattered grease as necessary.
- (8) The properties of grease deteriorate and its lubrication performance drops over time, so grease must be checked and added properly according to the use frequency of the machine.
- (9) Although the lubrication interval may vary according to operating conditions and the service environment, lubrication should be performed approximately every 100 km in travel distance (three to six months). Set the final lubrication interval/amount based on the actual machine.
- (10) Depending on the mounting orientation and access position, lubricant may not spread fully and poor lubrication may occur. Give full consideration to these factors in the design stage.
- (11) When using a Ball Screw, it is necessary to provide effective lubrication. Using the product without lubrication may increase wear of the rolling elements or shorten the service life. Table1 (B15-106) shows a guideline for the feed amount of oil.

[Storage]

When storing the Ball Screw, enclose it in a package designated by THK and store it in a room in a horizontal orientation while avoiding high temperature, low temperature and high humidity. After the product has been in storage for an extended period of time, lubricant inside may have deteriorated, so add new lubricant before use.

[Disposal]

Dispose of the product properly as industrial waste.

Precautions on Using Options for the Ball Screw

QZ Lubricator for the Ball Screw

For details regarding the QZ, see **B15-102**.

[Precaution on Selection]

Make sure the stroke length exceeds the total length of the screw shaft with the QZ Lubricator attached.

[Handling]

Take care not to drop or strike the product, which could result in injury or damage.

Keep air holes clear of grease or other obstructions.

The QZ Lubricator lubricates the raceway only, so it must be used in combination with regular greasing or lubrication.

In models equipped with the QZ Lubricator, raceways are provided with the minimum required level of lubrication. Please note: Use of the product in a vertical position, or other usage conditions, may cause lubricant to drip from the ball screw shaft.

[Service environment]

Be sure the service temperature of this product is between -10 to 50°C , and do not clean the product by immersing it in an organic solvent or white kerosene, or leave it unpacked.